



3Com® Switch 8800 Family Installation Guide

Switch 8807
Switch 8810
Switch 8814

3Com Corporation
350 Campus Drive
Marlborough, MA
USA 01752-3064

Copyright © 2006-2007, 3Com Corporation. All rights reserved. No part of this documentation may be reproduced in any form or by any means or used to make any derivative work (such as translation, transformation, or adaptation) without written permission from 3Com Corporation.

3Com Corporation reserves the right to revise this documentation and to make changes in content from time to time without obligation on the part of 3Com Corporation to provide notification of such revision or change.

3Com Corporation provides this documentation without warranty, term, or condition of any kind, either implied or expressed, including, but not limited to, the implied warranties, terms or conditions of merchantability, satisfactory quality, and fitness for a particular purpose. 3Com may make improvements or changes in the product(s) and/or the program(s) described in this documentation at any time.

If there is any software on removable media described in this documentation, it is furnished under a license agreement included with the product as a separate document, in the hard copy documentation, or on the removable media in a directory file named LICENSE.TXT or !LICENSE.TXT. If you are unable to locate a copy, please contact 3Com and a copy will be provided to you.

UNITED STATES GOVERNMENT LEGEND

If you are a United States government agency, then this documentation and the software described herein are provided to you subject to the following:

All technical data and computer software are commercial in nature and developed solely at private expense. Software is delivered as "Commercial Computer Software" as defined in DFARS 252.227-7014 (June 1995) or as a "commercial item" as defined in FAR 2.101(a) and as such is provided with only such rights as are provided in 3Com's standard commercial license for the Software. Technical data is provided with limited rights only as provided in DFAR 252.227-7015 (Nov 1995) or FAR 52.227-14 (June 1987), whichever is applicable. You agree not to remove or deface any portion of any legend provided on any licensed program or documentation contained in, or delivered to you in conjunction with, this User Guide.

Unless otherwise indicated, 3Com registered trademarks are registered in the United States and may or may not be registered in other countries.

3Com and the 3Com logo are registered trademarks of 3Com Corporation.

Cisco is a registered trademark of Cisco Systems, Inc.

Funk RADIUS is a registered trademark of Funk Software, Inc.

Aegis is a registered trademark of Aegis Group PLC.

Intel and Pentium are registered trademarks of Intel Corporation. Microsoft, MS-DOS, Windows, and Windows NT are registered trademarks of Microsoft Corporation. Novell and NetWare are registered trademarks of Novell, Inc. UNIX is a registered trademark in the United States and other countries, licensed exclusively through X/Open Company, Ltd.

IEEE and 802 are registered trademarks of the Institute of Electrical and Electronics Engineers, Inc.

All other company and product names may be trademarks of the respective companies with which they are associated.

ENVIRONMENTAL STATEMENT

It is the policy of 3Com Corporation to be environmentally-friendly in all operations. To uphold our policy, we are committed to:

Establishing environmental performance standards that comply with national legislation and regulations.

Conserving energy, materials and natural resources in all operations.

Reducing the waste generated by all operations. Ensuring that all waste conforms to recognized environmental standards. Maximizing the recyclable and reusable content of all products.

Ensuring that all products can be recycled, reused and disposed of safely.

Ensuring that all products are labelled according to recognized environmental standards.

Improving our environmental record on a continual basis.

End of Life Statement

3Com processes allow for the recovery, reclamation and safe disposal of all end-of-life electronic components.

Regulated Materials Statement

3Com products do not contain any hazardous or ozone-depleting material.

CONTENTS

ABOUT THIS GUIDE

Conventions	5
Related Documentation	6
About this Document	6

1 PRODUCT OVERVIEW

Preface	7
General Architecture	10
Fabric Modules	17
System Specifications	24
Software Features	25

2 I/O AND APPLICATION MODULES

Overview	29
3C17511 1-port 10GBASE-X (XENPAK)	29
3C17512 2-port 10GBASE-X (XFP) Module	30
3C17513 12-port 1000BASE-X (SFP) Module	31
3C17514 24-port 1000BASE-X (SFP) Module	32
3C17516 24-port 10/100/1000BASE-T Module	33
3C17525 1-port 10GBASE-X Advanced (XENPAK) Module	33
3C17526 4-port 10GBASE-X (XFP) Module	34
3C17527 2-port 10GBASE-X (XFP) Advanced Module	35
3C17528 48port 10/100/1000 BASE-T (RJ-45) Module	36
3C17530 24-port 1000BASE-X (SFP) Advanced Module	37
3C17531 24-port 10/100/1000BASE-T Advanced Module	37
3C17532 48-port 10/100/1000 BASE-T (RJ-45) Access Module	38
3C17533 24-port 1000BASE-X (SFP) IPv6 Module	39
3C17534 24-port 10/100/1000BASE-T IPv6 Module	40
3C17536 4-port 10GBASE-X (XFP) QUAD IPv6 Module	40
3C17537 2-port 10GBASE-X (XFP) IPv6 Module	41
3C17538 48-port 1000BASE-X (SFP) IPv6 Module	42
Application Modules	43
Transceivers	46
Switch 8800 Port Densities	47

3 INSTALLATION PREPARATION

Safety Recommendations	49
------------------------	----

Examining Installation Site	50
Installation Tools	52

4 SWITCH INSTALLATION

Confirming Installation Preparation	53
Installation Flow	53
Mounting the Switch in User-Supplied Cabinet	54
Connecting PGND Wire and Power Cord	59
Installing Cabling Rack	64
Installing Fan Tray	64
Installing PoE Lightning Protection Box	65
Installing I/O modules	66
Connecting Interface Cables	67
Cable Routing Recommendations	70
Cable Management	70
Verifying the Installation	73

5 DEBUGGING THE SYSTEM

Setting up Configuration Environment	75
Powering and Booting the Switch	76

6 SWITCH MONITORING AND MAINTENANCE

Monitoring the Switch	79
Hardware Maintenance	81
Upgrading the Software	86
Password Loss	95

A LIGHTNING PROTECTION OF THE SWITCH

Installing a Lightning Arrester for the AC Power	97
Installing a Lightning Arrester for the Network Port	98

B 3COM NETWORK MANAGEMENT

3Com Network Supervisor	101
3Com Network Director	102
3Com Network Access Manager	102
3Com Enterprise Management Suite	103
Integration Kit with HP OpenView Network Node Manager	103

ABOUT THIS GUIDE

This guide describes the 3Com® Switch 8800 and how to install hardware, configure and boot software, and maintain software and hardware. This guide also provides troubleshooting and support information for your switch.

This guide is intended for Qualified Service personnel who are responsible for configuring, using, and managing the switches. It assumes a working knowledge of local area network (LAN) operations and familiarity with communication protocols that are used to interconnect LANs.



Always download the Release Notes for your product from the 3Com World Wide Web site and check for the latest updates to software and product documentation:

<http://www.3com.com>

Conventions

Table 1 lists icon conventions that are used throughout this guide.

Table 1 Notice Icons

Icon	Notice Type	Description
	Information note	Information that describes important features or instructions.
	Caution	Information that alerts you to potential loss of data or potential damage to an application, system, or device.
	Warning	Information that alerts you to potential personal injury.

Table 2 lists text conventions that are used throughout this guide.

Table 2 Text Conventions

Convention	Description
Screen displays	This typeface represents information as it appears on the screen.
Keyboard key names	If you must press two or more keys simultaneously, the key names are linked with a plus sign (+), for example: Press Ctrl+Alt+Del
The words "enter" and "type"	When you see the word "enter" in this guide, you must type something, and then press Return or Enter. Do not press Return or Enter when an instruction simply says "type."

Table 2 Text Conventions

Convention	Description
Words in <i>italics</i>	<p>Italics are used to:</p> <ul style="list-style-type: none"> Emphasize a point. Denote a new term at the place where it is defined in the text. Identify menu names, menu commands, and software button names. <p>Examples:</p> <ul style="list-style-type: none"> From the <i>Help</i> menu, select <i>Contents</i>. Click <i>OK</i>.
Words in bold	<p>Boldface type is used to highlight command names. For example, "Use the display user-interface command to..."</p>

Related Documentation

The following manuals offer additional information necessary for managing your Switch 8800:

- *Switch 8800 Command Reference Guide* — Provides detailed descriptions of command line interface (CLI) commands, that you require to manage your Switch 8800.
- *Switch 8800 Configuration Guide*— Describes how to configure your Switch 8800 using the supported protocols and CLI commands.
- *Switch 8800 Release Notes* — Contains the latest information about your product. If information in this guide differs from information in the release notes, use the information in the *Release Notes*.

These documents are available in Adobe Acrobat Reader Portable Document Format (PDF) on the 3Com World Wide Web site:

<http://www.3com.com/>

About this Document



3Com supports only the commands that are described in this document set. You may encounter commands in the device's command line interface (CLI) that are not described in this guide. Any command that you see in the CLI but is not described in this guide is not supported in this version of the software. Unsupported commands may result in a loss of data and you enter them at your own risk.

1

PRODUCT OVERVIEW

Preface

The 3Com Switch 8800 Family of Routing Switches (referred to as the Switch 8800 Family) are intelligent, multi-layer modular LAN switches and are ideal for enterprise environments where non-stop availability of critical applications and the highest performance, security, and granular control are required. The Switch 8800 Family delivers high density Gigabit and 10 Gigabit switching in an integrated chassis platform. Built-in support for IPv6, MPLS, Power over Ethernet (PoE), and 1.44 Tbps backplane capacity ensures unprecedented investment protection.

Resilient Layer-3 routing, hot-swap modules, and redundant power, along with sub one-second fabric fail over on the Switch 8800, ensure (24 x 7) availability to support the most demanding enterprise core and campus environments. Advanced Quality of Service features such as bandwidth management and packet classification optimize quality for real-time voice and video applications. Intrusion prevention security capabilities such as IEEE 802.1X Network Login and Access Control Lists ensure that only authorized users can access network resources.

The Switch 8800 is focused on delivering functionality towards the higher end of the large Enterprise, with a 4-port 10 Gigabit Module, high density 48-port Gigabit Modules, as well as a group of Advanced Modules with support for larger routing tables and/or MPLS. Power over Ethernet (PoE) is built into all Switch 8800s.

Application modules for the Switch 8800 provide the flexibility to add a firewall, IPsec encryption, network monitoring with NetFlow, and Layer 2 VPN networking using Virtual Private LAN Service (VPLS) by simply adding a module to the chassis.

Currently, the Switch 8800 Family include the following models:

- Switch 8807: This model provides up to 600 Gbps switching capacity. It supports (for example) up to 240 GE ports and 20 x 10GE ports.

Figure 1 3Com Switch 8807 (7-Slot Chassis)



- Switch 8810: This model provides up to 960 Gbps switching capacity. It supports (for example) up to 192 GE ports and 32 x 10GE ports.

Figure 2 3Com Switch 8810 (10-Slot Chassis)



- Switch 8814: This model provides up to 1.44 Tbps switching capacity. It supports (for example) up to 576 GE ports and 48 x 10GE ports.

Figure 3 3Com Switch 8814 (14-Slot Chassis)



General Architecture

The Switch 8800 Family use integrated chassis, which can be subdivided into power area, board area, backplane and fan area.

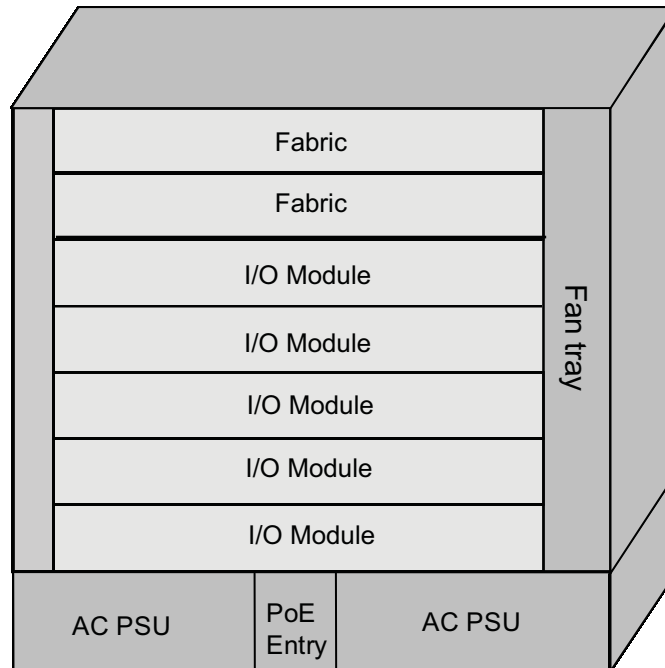
Chassis and Slots **Switch 8807****Figure 4** Switch 8807 slots

- The Switch 8807 chassis provides seven slots in its board area: The top two accommodate fabrics, which can operate in 1+1 redundancy mode; the remaining five accommodate I/O or application modules, which you can select from various available models. All modules in this area are hot-swappable.
- At the bottom of the chassis is the power area that can accommodate one PoE entry module and two PSUs. The two PSUs are online-swappable; they can operate in 1+1 redundancy mode. The switch supports AC power inputs.
- On the right of the chassis is the fan area that contains one vertical hot-swappable fan tray. The fan tray draws and exhausts air from left to right.

Switch 8810

Figure 5 Switch 8810 slots

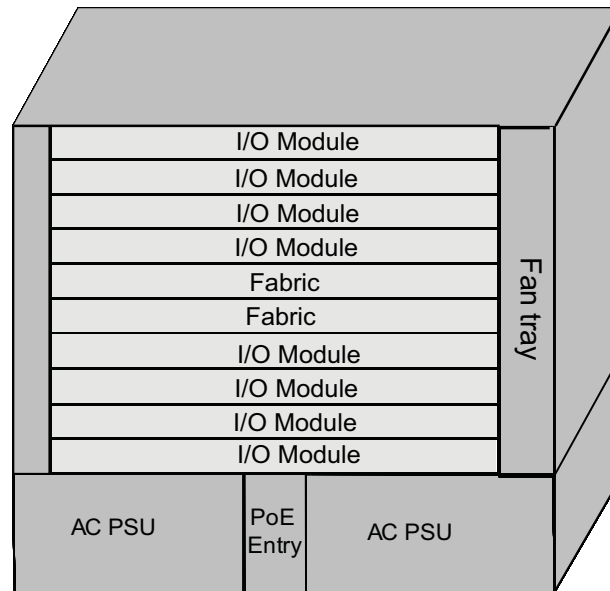

- The Switch 8810 chassis provides ten slots in its board area: The middle two accommodate fabric modules, which can operate in 1+1 redundancy mode; the remaining eight accommodate I/O or application modules, which you can select from various available models. All modules in this area are hot-swappable.
- At the bottom of the chassis is the power area that can accommodate one PoE entry module and two PSUs. The two PSUs are online-swappable; they can operate in 1+1 redundancy mode. The switch supports AC power inputs.
- On the right of the chassis is the fan area that contains one vertical hot-swappable fan tray. The fan tray draws and exhausts air from left to right.

Switch 8814

Figure 6 Switch 8814 slots

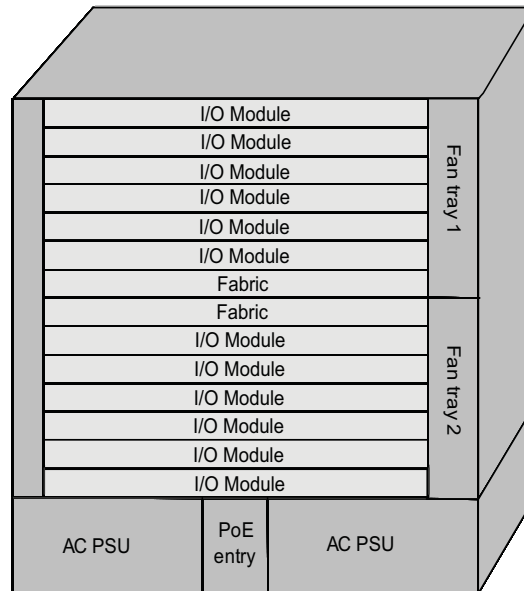

- The Switch 8814 chassis provides 14 slots in its board area: The middle two accommodate fabric modules, which can operate in 1+1 redundancy mode; the remaining 12 accommodate I/O or application modules, which you can select from various available models. All modules in this area are hot-swappable.
- At the bottom of the chassis is the power area that can accommodate one PoE entry module and two PSUs. The two PSUs are online-swappable. The switch supports AC power inputs.
- On the right of the chassis is the fan area that contains two vertical hot-swappable fan trays. The fan trays draw and exhaust air from left to right.

Backplane The backplane of the Switch 8800 Family allows high-speed data exchange between fabrics and I/O modules, as well as the exchange of various management and control signals in the system.

Functions

The following are the main functions of the backplane:

- Providing communication channels for signal exchange between boards
- Supporting board hot-swapping
- Supporting auto-discovering boards in slots
- Connecting PSUs, distributing power and providing monitor channels to various components (PSUs, fabrics and I/O modules) in the chassis.

Structure

- Switch 8807

The Switch 8807 uses a passive backplane, which provides five I/O module interfaces, two fabric interfaces, one fan interface, and three -48V power interfaces (two for PSUs and one for PoE entry module).

- Switch 8810

The Switch 8810 uses a passive backplane, which provides eight I/O module interfaces, two fabric interfaces, one fan interface, and three -48V power interfaces (two for PSUs and one for PoE entry module).

- Switch 8814

The Switch 8814 uses a passive backplane, which provides 12 I/O module interfaces, two fabric interfaces, two fan interfaces, and three -48V power interfaces (two for PSUs and one for PoE entry module).

AC Power System



- The Switch 8800 Family supports AC power inputs.
- The Switch 8800 Family supports 1+1 power supply redundancy.
- The PSUs of the Switch 8800 Family are online-swappable.

The Switch 8800 Family supports AC power inputs. The power frame is at the bottom of the chassis, with a height of 3U. In the same slot, you can insert an AC PSU. The power frame is in different compartment from the functional board frame and connected to the latter with cables, which are routed along the back of the chassis. The power supply is cooled by built-in fans of the PSUs, which draw air into the chassis from the front and exhaust air out of the chassis from the back.

Table 1 Specifications for AC PSUs

Item	Specifications		
	Switch 8807	Switch 8810	Switch 8814
Rated voltage range	100 to 240 VAC, 50/60 Hz	100 to 120 VAC, 60 Hz 200 to 240 VAC, 50 Hz	100 to 120 VAC, 60 Hz 200 to 240 VAC, 50 Hz
Max voltage range	90 to 264 VAC, 50/60 Hz	90 to 264 VAC, 50/60 Hz	90 to 264 VAC, 50/60 Hz
Max input current	15 A	15 A	15 A
Max output power	1200 W	1200 W (90 to 160 V) 2000 W (160 to 264 V)	1200 W (90 to 160 V) 2000 W (160 to 264 V)

PoE Power Supply

The Switch 8800 Family supports Power over Ethernet (PoE). With this feature, a Switch 8800 Family switch equipped with an external PoE power supply and PoE-capable modules can deliver 48 VDC to its remotely powered devices (PDs, such as IP phones, WLAN APs and network cameras) through twisted pairs.

- The Switch 8800 Family can supply power to remote PDs through the Ethernet electrical ports on the I/O modules. Each I/O module can simultaneously supply power to up to 48 PDs with the maximum distance of 100 m (328.1 feet).
- Each Ethernet port can deliver up to 15.4 W to its PD.

- A Switch 8800 supports up to 4500 W (220 V)/2250 W (110 V) power to its PDs. It determines whether to deliver power to a newly detected PD depending on the power it currently supplied.

PoE entry area

The PoE-supported Switch 8807/Switch 8810/Switch 8814 chassis has a PoE entry area between the two power supply units. You can insert a PoE 3C17510 Switch 8800 PoE Entry Module into this area, and connect this module to a 3C17509 Switch 8800 External PoE Power Rack so as to import the output power of the External Power Rack unit.

Figure 7 PoE entry module

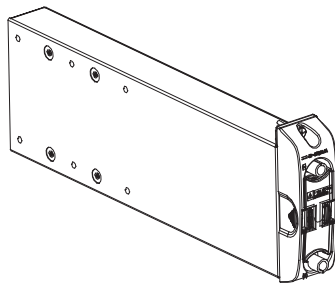

External PoE Power Rack (3C17509)

The Switch 8800 External Power Rack is available for the Switch 8807, Switch 8810, and Switch 8814. The External Power Rack has three AC inputs and one DC outputs. Figure 8 shows its front panel.

Figure 8 Front panel of the 3C17509 Switch 8800 External Power Rack PoE power supply

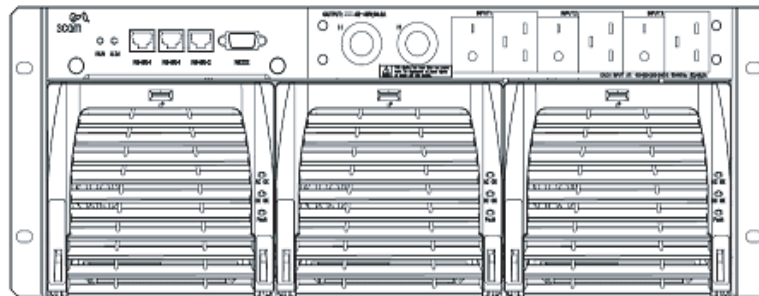

The external PoE power system supports 2+1 redundancy and online-swapping of PSUs.

To implement the PoE function on the Switch 8800 Family, PoE-capable interface module is required. There are two modules are PoE-capable:

- 3C17528 Switch 8800 48-port 10/100/1000BASE-T
- 3C17532 Switch 8800 48-port 10/100/1000BASE-T Access

Both of these I/O Modules are PoE-capable, and will function with the addition of a 3C17529 PoE Option (PoE DIMM Module).

Table 2 describes typical equipment configurations and specifications of external PoE power system.

Table 2 Typical equipment configurations and specifications of external PoE power system

Item	Description
Physical dimensions (H x W x D)	177 x 486 x 320.5 mm (7.0 x 19.1 x 12.6 in.)
System controller	One
Rectifier	Two NP2500UAC (required) + one redundant NP2500UAC (optional)
AC accessory	Three AC inputs and switches Three-phase AC voltage detection circuit Input voltage range: 90 to 290 VAC; rated voltage and current: 250 VAC, 20 A
DC accessory	A single DC output, with max output current of 93 A
Max power consumption	4500 W

The external PoE power system has monitor function. It provides one system monitoring module, one RS232 and two RS485 monitoring interfaces. The system monitoring module reports the running information of the PSUs in the system to a fabric through RS232 or RS485 interface and indicates alarm status by the alarm LED (ALM). You can connect cables to the interfaces from the front as well as the rear of the frame.



The external PoE power system for the Switch 8800 Family only supports the RS485 monitoring interface.

Table 3 LEDs of external PoE power system

LED	Label	Color	Normal state	Abnormal state	Abnormal reason
Input power LED	AC	Green	ON	OFF	Loss of AC input power, or blown fuse
Output power LED	DC	Green	ON	OFF	No DC output from PSU
Fault LED	Fault	Red	OFF	ON	Irreversible fault occurred in PSU
Running status LED	RUN	Green	ON	OFF	PSU shutdown or PSU running trouble
Alarm LED	ALM	Red	OFF	ON	Loss of AC input power, under-voltage or over-voltage input, under-voltage or over-voltage output, or PSU fault

MBUS Introduction

The MBUS is a service-independent maintenance and test bus. No service traffic goes through the MBUS. The shutdown and reset of the MBUS does not affect the services on the switch, and faults that have occurred on modules do not affect the MBUS.

Through the MBUS, the system instructs the MBUS modules on individual cards to power on/off the cards one by one in turn, thus prevent power surging. The MBUS module software must support online upgrade.

Role and function

The MBUS system is powered by 5 V from the MBUS on the fabric. The 5 V power on the two fabrics are redundant to each other.

Each MBUS module is attached to the MBUS, which contains two control lines: MBUS0 and MBUS1.

Each card has an independent MBUS module, those on the fabrics are primary MBUS modules, and those on application modules are secondary MBUS modules.

When the fabrics operate in redundancy mode, the MBUS module on the active fabric is the active module, and the one on the standby fabric is the standby module.

The MBUS uses a controller area network (CAN) bus as its control bus, that uses the 1:1 hot backup and transfers control information at 1 Mbps.

- Fan Tray**
- The Switch 8807 uses one 25 W fan tray, which contains four 120 x 120 x 25.4 mm (4.7 x 4.7 x 1.0 in.) axial fan units. The fans can be governed in two modes: fabric-controlled or temperature-controlled. They operate at -48 VDC supplied from the backplane.
 - The Switch 8810 uses one 35 W fan tray, which contains six 120 x 120 x 25.4 mm (4.7 x 4.7 x 1.0 in.) axial fan units. The fans can be governed in two modes: fabric-controlled or temperature-controlled. They operate at -48 VDC supplied from the backplane.
 - The Switch 8814 uses two 25 W fan trays, each of which contains four 120 x 120 x 25.4 mm (4.7 x 4.7 x 1.0 in.) axial fan units (and totally eight for the two fan trays). The fans can be governed in two modes: fabric-controlled or temperature-controlled. They operate at -48 VDC supplied from the backplane.

Figure 9 Fan tray panel of the Switch 8800 Family

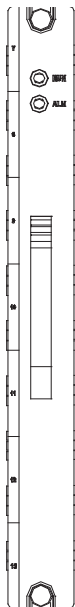

Table 4 LEDs on fan tray panel

LED	Color	Status	Status
RUN	Green	OFF	The fan tray is faulty.
		ON	The fan tray is operating normally.
ALM	Red	OFF	The fan tray is operating normally.
		ON	The fan tray is faulty.

Fabric Modules

The Switch Fabric serves as the core of the Switch 8800 Family. The following fabric models are available to the Switch 8800 Family:

- 3C17508 - 3Com Switch 8800 360 Gbps Fabric
- 3C17539 - 3Com Switch 8800 720 Gbps Fabric

These fabric modules provide:

- Route calculating and forwarding table maintenance.
- Integrating Crossbar switching fabric to accomplish service exchange between different boards.
- System configuration and monitoring functions, which allows the system to monitor other boards and upgrade/reset service board software.

360 Gbps Switch Fabric Technical specifications

This model applies to the 3C17508. See Table 5 for its specifications.

Table 5 360 Gbps Switch Fabric specifications

Item	Specifications
CPU	MPC755
Boot ROM	512 KB
SDRAM	512 MB (expandable to 1 GB)
Physical dimensions (W x D)	366.7 x 340 mm (14.4 x 13.4 in.)
Port	One Console port, for local configuration management One AUX port, for remote dialup configuration management One 10Base-T/100Base-TX port, for software upgrade and network management One RS232/485 port, for connecting external PoE power frame to provide the PoE function One hot-swap-supported CF port
Max power consumption	60 W

Panel

On its panel, the 360 Gbps Switch Fabric provides a CF port, CF LED (CFS), 10Base-T/100Base-TX port, RS232/485 port, Console port, AUX port, RESET button, I/O module status LEDs, and 360 Gbps Switch Fabric status LEDs (SFS, ACT, ALM, RUN) in turn, as shown in Figure 10.

Table 8 RS232/485 port specifications

Item	Description
Service	The port for monitoring and communication with the external subsystem, such as external PoE power supply module

- Console port

The Console port uses an RJ-45 connector. It can be connected to a background terminal for system debugging, maintenance, management, and host software loading.

Table 9 Console port specifications

Item	Description
Connector	RJ-45
Standard	Asynchronous EIA/TIA-232
Baud rate	9600 bps (default)
Transmission segment	15 m (49 ft.)
Service	Connects a serial port of a local PC and runs terminal emulation on the PC.



You can choose your own baud rate for the Console port.

- AUX port

The AUX port uses an RJ-45 connector. The port can serve as a backup port for the Console port to connect a background terminal, or directly connect a modem device, for remote system debugging, configuration, maintenance and management.

Table 10 AUX port specifications

Item	Description
Connector	RJ-45
Standard	Asynchronous EIA/TIA-232
Service	Connects a serial port of a PC (through a Modem pair for a remote PC) and runs terminal emulation on the PC.

RESET button

You can press the RESET button on the panel to reset the 360 Gbps Switch Fabric module.

Status LEDs

- CF status LED

You can learn the operating status of the CF card by reading the CF status LED on the panel.

Table 11 CF status LED

LED	Status	
CFS	ON	The CF card is in position and is idle. You cannot remove the card.
	Blinking	The CF card is in position and reading/writing data. You cannot remove the card.
	OFF	The CF card is out of position or offline (you can force the in-position CF card to go offline using the appropriate background command). You can remove/insert the card.

- Status LEDs for I/O module

The 360 Gbps Switch Fabric module has 12 pairs of LEDs to indicate the operating status of 12 I/O module.

Table 12 Status LEDs for I/O module

LED	Status	
RUN	ON	The module is faulty.
	OFF	The module is faulty or out of position.
	Blinking (1s)	The module is running normally.
	Fast blinking (125 ms)	The module is booting or not registered successfully.
ALM	ON	The module has alarms.
	OFF	The module has no alarms or is out of position.
0~5, 8~13	Indicate slots 0 through 5 and slots 8 through 13	

- Status LEDs for the 360 Gbps Switch Fabric module

You can learn the operating status of 360 Gbps Switch Fabric module by reading the SFS, ACT, ALM and RUN LEDs on it. The following table gives a summary of the four LEDs.

Table 13 Status LEDs for the 360 Gbps Switch Fabric module

360 Gbps Switch Fabric LED	Status	
SFS	ON	The switching fabric unit is active.
	OFF	The switching fabric unit is standby.
RUN	Green	The 360 Gbps Switch Fabric module is faulty.
	OFF	The 360 Gbps Switch Fabric module is faulty.
	Green blinking	The 360 Gbps Switch Fabric module runs normally.
ALM	Red	The 360 Gbps Switch Fabric module has alarms.
	OFF	The 360 Gbps Switch Fabric module has no alarms.
ACT	Green	The 360 Gbps Switch Fabric module is active.
	OFF	The 360 Gbps Switch Fabric module is standby.

720 Gbps Switch Fabric Technical specifications

This model applies to the 3C17539. See Table 5 for its specifications.

Table 14 720 Gbps Switch Fabric specifications

Item	Specifications
CPU	MPC755
Boot ROM	512 KB
SDRAM	512 MB (expandable to 1 GB)
Physical dimensions (W x D)	366.7 x 340 mm (14.4 x 13.4 in.)
Port	One Console port, for local configuration management One AUX port, for remote dialup configuration management One 10Base-T/100Base-TX port, for software upgrade and network management One RS232/485 port, for connecting external PoE power frame to provide the PoE function One hot-swap-supported CF port
Max power consumption	110 W

Panel

On its panel, the 720 Gbps Switch Fabric provides a CF slot, CF LED (CFS), 10Base-T/100Base-TX port, RS232/485 port, Console port, AUX port, RESET button, I/O module status LEDs, and 360 Gbps Switch Fabric status LEDs (SFS, ACT, ALM, RUN) in turn, as shown in Figure 10. The fabric ships with a CF memory card.

Figure 11 720 Gbps Switch Fabric panel



Compact Flash (CF slot)

The 720 Gbps Switch Fabric module provides a CF port to accommodate a standard CF card, where you can save logging information, host version information, alarming and other diagnostic information and conveniently upgrade software online.

Management Ports

The Management 10Base-T/100Base-TX port uses an RJ-45 connector. It can connect a background terminal for system program loading and debugging, or connect a network management station for remote system management.

Table 15 Management 10Base-T/100Base-TX port specifications

Item	Description
Connector	RJ-45
Number of ports	One
Rate	10 Mbps, half duplex/full duplex 100 Mbps, half duplex/full duplex

Table 15 Management 10Base-T/100Base-TX port specifications

Item	Description
Max. transmission segment over the selected medium	100 m (328 ft.) over the category-5 twisted pair cable (crossover cable is required).
Service	System program upgrade and network management

The following table describes the status LEDs for the management 10Base-T/100Base-TX port.

Table 16 Status LEDs for the management 10Base-T/100Base-TX port

LED	Status	Description
LINK	OFF	No link is present.
	ON	A link is present.
ACT	OFF	No packets are transmitted/received on the port.
	Blinking	Packets are being transmitted/received on the port.

- RS232/485 port

The RS232/485 port uses RJ-45 connector, for connecting external PoE power frame when supported and monitoring its status.

Table 17 RS232/485 port specifications

Item	Description
Connector	RJ-45
Number of ports	One RS 232 port and one RS485 port
Service	The port for monitoring and communication with the external subsystem, such as external PoE power supply module

- Console port

The Console port uses an RJ-45 connector. It can be connected to a background terminal for system debugging, maintenance, management, and host software loading.

Table 18 Console port specifications

Item	Description
Connector	RJ-45
Standard	Asynchronous EIA/TIA-232
Baud rate	9600 bps (default)
Transmission segment	15 m (49 ft.)
Service	Connects a serial port of a local PC and runs terminal emulation on the PC.



You can choose your own baud rate for the Console port.

- AUX port

The AUX port uses an RJ-45 connector. The port can serve as a backup port for the Console port to connect a background terminal, or directly connect a modem device, for remote system debugging, configuration, maintenance and management.

Table 19 AUX port specifications

Item	Description
Connector	RJ-45
Standard	Asynchronous EIA/TIA-232
Service	Connects a serial port of a PC (through a Modem pair for a remote PC) and runs terminal emulation on the PC.

RESET button

You can press the RESET button on the panel to reset the 720 Gbps Switch Fabric module.

Status LEDs

■ CF status LED

You can learn the operating status of the CF card by reading the CF status LED on the panel.

Table 20 CF status LED

LED	Status	
CFS	ON	The CF card is in position and is idle. You cannot remove the card.
	Blinking	The CF card is in position and reading/writing data. You cannot remove the card.
	OFF	The CF card is out of position or offline (you can force the in-position CF card to go offline using the appropriate background command). You can remove/insert the card.

■ Status LEDs for I/O module

The 720 Gbps Switch Fabric module has 12 pairs of LEDs to indicate the operating status of 12 I/O module.

Table 21 Status LEDs for I/O module

LED	Status	
RUN	ON	The module is faulty.
	OFF	The module is faulty or out of position.
	Blinking (1s)	The module is running normally.
	Fast blinking (125 ms)	The module is booting or not registered successfully.
ALM	ON	The module has alarms.
	OFF	The module has no alarms or is out of position.
0~5, 8~13	Indicate slots 0 through 5 and slots 8 through 13	

■ Status LEDs for the 720 Gbps Switch Fabric module

You can learn the operating status of 720 Gbps Switch Fabric module by reading the SFS, ACT, ALM and RUN LEDs on it. The following table gives a summary of the four LEDs.

Table 22 Status LEDs for the 720 Gbps Switch Fabric module

360 Gbps Switch Fabric LED	Status	
SFS	ON	The switching fabric unit is active.
	OFF	The switching fabric unit is standby.
RUN	Green	The 720 Gbps Switch Fabric module is faulty.
	OFF	The 720 Gbps Switch Fabric module is faulty.
	Green blinking	The 720 Gbps Switch Fabric module runs normally.
ALM	Red	The 720 Gbps Switch Fabric module has alarms.
	OFF	The 720 Gbps Switch Fabric module has no alarms.
ACT	Green	The 720 Gbps Switch Fabric module is active.
	OFF	The 720 Gbps Switch Fabric module is standby.

RESET button

You can press the RESET button on the panel to reset the 720 Gbps Switch Fabric.

Status LEDs

See the section “Status LEDs” on page 19.

System Specifications

The following table summarizes the physical specifications of the Switch 8800 Family.

Table 23 Technical specifications of the Switch 8800 Family

Item	Switch 8807	Switch 8810	Switch 8814
Dimensions (H x W x D)	486 x 436 x 450 mm (19.1 x 17.2 x 17.7 in.)	619 x 436 x 450 mm (24.4 x 17.2 x 17.7 in.)	753 x 436 x 450 mm (29.6 x 17.2 x 17.7 in.)
Weight (full load)	600 kg (143 lb)	80 kg (176 lb)	100 kg (220 lb)
Max power consumption	1200 W	2000 W	2000 W
Switching capacity (see Note 1)	Fab360: 600 Gbps (see Note 2)	Fab360: 480Gbps Fab720: 960Gbps	Fab360: 720Gbps Fab720: 1440Gbps
Number of VLANs	4 K		
Maximum MAC address table size	14 K/per module, total 14 K x number of modules See Note 3		
Forwarding table entries	128 K/256 K		
Number of fabric slots	2	2	2

Table 23 Technical specifications of the Switch 8800 Family

Item	Switch 8807	Switch 8810	Switch 8814
fabric module type	360 Gbps Fabric	360 Gbps Switch Fabric 720 Gbps Switch Fabric	360 Gbps Switch Fabric 720 Gbps Switch Fabric
Number of I/O module slots	5	8	12
User interface	10/100/1000BASE-TX RJ45 1000BASE-X (SFP) 10BASE-X (XENPAK) 10BASE-X (XFP)		
Operating temperature	0 to 40C (32 to 104F)		
Operating humidity (noncondensing)	10% to 90%		
Storage temperature	-10 to 70C (14 to 158F)		
Storage humidity	10% to 90%		



Note 1: The switching capacity in the above table is calculated based on two load-sharing fabrics.

Note 2: The 7-slot has additional backplane traces per slot compared to the 14-slot and the 10- slot chassis. The additional traces enable higher capacity per slot using the 360G Fabric compared to the 10-slot and 14-slot chassis.

Note 3: See the Switch 8800 Configuration Guide for rules and limitations.

Software Features

The software of the Switch 8800 Family uses fully distributed processing and runs on 3Com network operating system Comware. The following table summarizes the supported software features.

Table 24 Software features of the Switch 8800 Family

Item	Description
VLAN	IEEE 802.1Q-compliant VLAN Port-based, protocol-based (8 groups), IP subnet-based VLAN division GARP VLAN registration protocol (GVRP) Super VLAN Isolate user VLAN Guest VLAN Dynamic VLAN
STP	IEEE 802.1d/IEEE 802.1w/IEEE 802.1s-compliant spanning tree protocol (STP)/rapid STP (RSTP)/multiple STP (MSTP)

Table 24 Software features of the Switch 8800 Family

Item	Description
Flow control	IEEE 802.3x flow control (full duplex) Back pressure flow control (half duplex)
Broadcast/multicast suppression	Supported
Multicast	Internet group management protocol (IGMP) snooping IGMP Internet group management protocol (IGMP) v2 Protocol-independent multicast-dense mode (PIM-DM) Protocol-independent multicast-sparse mode (PIM-SM) Multicast source discovery protocol (MSDP) Multiprotocol border gateway protocol (MBGP) Any-RP
IP routing	Static routing Routing information protocol (RIP) v1/v2 Open shortest path first (OSPF) v2 Border gateway protocol (BGP) Intermediate system-to-intermediate system (IS-IS) Equal cost route forwarding Routing policy Policy routing OSPF/IS-IS/BGP graceful restart (GR)
Link aggregation	Aggregation across cards LACP
DHCP	DHCP server DHCP relay DHCP Option 82
Mirroring	Port-based mirroring
Multiprotocol Label Switching (MPLS)	L3 MPLS VPN, inter-domain MPLS VPN, hierarchy of PE (HoPE), CE dual homing, MCE, multi-role host VLL: Martini, Kompella, and CCC mode VPLS
QoS	Traffic classification based on port, MAC address, VLAN, IP address, IP priority, TCP/UDP port number, DSCP priority, Type of service (ToS) priority, class of service (CoS) priority, etc. Traffic monitoring, with granularity of 8 Kbps Traffic shaping Priority mark/remark Queue scheduling: strict priority (SP), weighted round Robin (WRR) and SP + WRR <par 8 priority queues for each port Congestion avoidance algorithms: tail drop (TD) and weighted random early detection (WRED)

Table 24 Software features of the Switch 8800 Family

Item	Description
Security	Hierarchical user management and password protection Password control 802.1x authentication Packet filtering Port-based broadcast frame suppression, speed calculation in bytes or packets Protection from attacks by virus packets, such as DOS attacks AAA/RADIUS/HWTACACS SSH 2.0 (security shell) Firewall IPsec Education network accounting
QinQ	Port VLAN VPN Flexible QinQ
Network Monitoring feature	NetFlow v5/v8/v9
Management and maintenance	Configuration through the command line interface (CLI) Configuration through the Console/AUX port Telnet configuration/maintenance through Ethernet ports Modem dialup configuration/maintenance through AUX port SNMP management, with the 3Com network management application, RMON (remote monitoring), and 1/2/3/9 groups of MIBs. System logging Hierarchical alarming Debugging information output ping and tracert commands NQA
Loading and upgrade	Loading and upgrade using the XModem protocol Loading and upgrade using FTP/TFTP Loading of BootROM and host software



All specifications are subject to changes without notice. For up-to-date information, please contact 3Com marketing or technical support personnel.

2

I/O AND APPLICATION MODULES

Overview

The Switch 8800 Family are modular switches that are designed following industry standards. The following I/O modules are available to the Switch 8800 Family:

Table 25 I/O modules available to the Switch 8800 Family

I/O module	User interface
3C17511	1-port 10GBASE-X (XENPAK)
3C17512	2-port 10GBASE-X (XFP)
3C17513	12-port 1000BASE-X (SFP)
3C17514	24-port 1000BASE-X (SFP)
3C17516	24-port 10/100/1000BASE-T (RJ-45)
3C17525	1-port 10GBASE-X (XENPAK) Advanced
3C17526	4-port 10GBASE-X (XFP)
3C17527	2-port 10GBASE-X (XFP) Advanced
3C17528	48-port 10/100/1000 BASE-T (RJ-45)
3C17530	24-port 1000BASE-X (SFP) Advanced
3C17531	24-port 10/100/1000BASE-T (RJ-45) Advanced
3C17532	48-port 10/100/1000BASE-T (RJ-45) Access
3C17533	24-port 1000BASE-X (SFP) IPv6 Module
3C17534	24-port 10/100/1000BASE-T (RJ-45) IPv6 Module
3C17536	4-port 10GBASE-X (XFP) QUAD IPv6
3C17537	2-port 10GBASE-X (XFP)
3C17538	48-port 1000BASE-X (SFP) IPv6
3C17542	Network Monitoring Module
3C17546	Firewall Module
3CR1754766	IPsec Module
3C17548	Virtual Private LAN Service (VPLS)

3C17511 1-port 10GBASE-X (XENPAK)

Specifications

This section provides specifications for the 1-port 10GBASE-X (XENPAK) 3C17511 module.

Table 26 3C17511 module specifications

Item	Specification
CPU	MPC8245

Table 26 3C17511 module specifications

Item	Specification
Boot ROM	512 KB
SDRAM	128 MB/256 MB
Physical dimensions (W x D)	366.7 x 340 mm(14.4 x 13.4 in.)
Max power consumption	45 W
Number of ports	One
Connector	XENPAK/SC
Rate	10 Gbps

Panel and LEDs **Figure 12** 3C17511 module panel

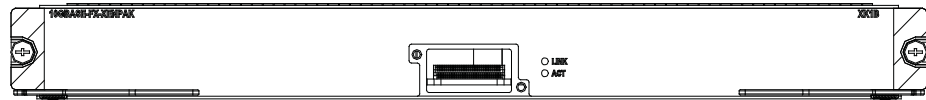

The 3C17511 module has two port LEDs for the 10GE port on its panel.

Table 27 Port LEDs on the 3C17511 module

LED	Status	Meaning
LINK	OFF	No link is present.
	Green ON	A link is present.
ACT	OFF	No packets are transmitted/received on the port.
	Orange blinking	Packets are being transmitted/received on the port.

Matching Cable See Table 66 on page 46 for the XENPAK optical modules available to the 10GE XENPAK/SC optical/electrical port on the 3C17511 module and their matching cable types, which you can select as required.

3C17512 2-port 10GBASE-X (XFP) Module

This section provides specifications for the 2-port 10GBASE-X (XFP) module (3C17512).

Specifications The 3C17512 modules provide two 10GBASE-X XFP/LC ports.

Table 28 3C17512 module specifications

Item	Specification
CPU	MPC8245
Boot ROM	512 KB
SDRAM	128 MB/256MB
Physical dimensions (W x D)	366.7 x 340 mm (14.4 x 13.4 in.)
Max power consumption	87 W
Number of ports	Two
Connector	XFP

Table 28 3C17512 module specifications

Item	Specification
Rate	10 Gbps

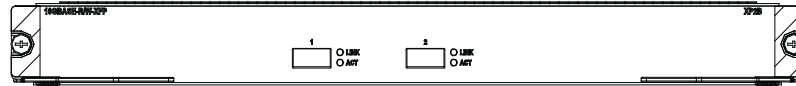
Panel and LEDs **Figure 13** 3C17512 module panel

The 3C17512 module has two LEDs for each optical port on its panel.

Table 29 1000 Mbps optical port LEDs on the 3C17512 module

LED	Status	Meaning
LINK	OFF	No link is present.
	Green	A link is present.
ACT	OFF	No packets are transmitted/received on the port.
	Orange blinking	Packets are being transmitted/received on the port.

Matching Cable See Table 66 on page 46 for the XFP optical modules available for the 10 Gbps XFP optical ports on the 3C17512 module and their matching cable types, which you can select as required.

3C17513 12-port 1000BASE-X (SFP) Module

This section provides specifications for the 12-port 1000BASE-X (SFP) module (3C17513)

Specifications The 3C17513 module provides 12 x 1000 Mbps SFP/LC optical ports.

Table 30 3C17513 module specifications

Item	Specification
CPU	MPC8245
Boot ROM	512 KB
SDRAM	128 MB
Physical dimensions (W x D)	366.7 x 340 mm (14.4 x 13.4 in.)
Max power consumption	55 W
Number of ports	12
Connector	SFP/LC
Rate	1.25 Gbps

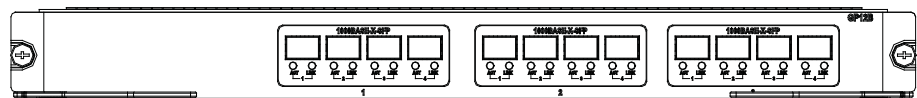
Panel and LEDs **Figure 14** 3C17513 module panel

The 3C17513 module has two LEDs for each port on its panel.

Table 31 Port LEDs on the 3C17513 module

LED	Status	Meaning
LINK	OFF	No link is present.
	Green	A link is present.
ACT	OFF	No packets are transmitted/received on the port.
	Orange blinking	Packets are being transmitted/received on the port.

Matching Cable See Table 66 on page 46 for the SFP optical modules available to the SFP optical ports on the 3C17513 module and their matching cable types, which you can select as required.

3C17514 24-port 1000BASE-X (SFP) Module

This section provides specifications for the 24-port 1000BASE-X (SFP) module (3C17514).

Specifications The 3C17514 module provides 24 1000BASE-X (SFP) ports.

Table 32 3C17514 module specifications

Item	Specification
CPU	MPC8245
Boot ROM	512 KB
SDRAM	128 MB/256 MB
Physical dimensions (W x D)	366.7 x 340 mm (14.4 x 13.4 in.)
Max power consumption	100 W
Number of ports	24
Connector	SFP/LC
Rate	1.25 Gbps

Panel and LEDs **Figure 15** 3C17514 module panel

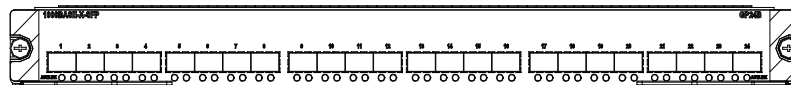

The 3C17514 module has two LEDs for each 1000 Mbps optical port on its panel.

Table 33 Port LEDs on the 3C17514 module

LED	Status	Meaning
LINK	OFF	No link is present.
	Green	A link is present.
ACT	OFF	No packets are transmitted/received on the port.
	Orange blinking	Packets are being transmitted/received on the port.

Matching Cable You can select appropriate SFP optical modules for the 1000 Mbps SFP optical ports on the 3C17514 module according to your needs. For description of SFP optical modules available to the SFP optical ports and their matching cable types, see Table 66 on page 46.

3C17516 24-port 10/100/1000BASE-T Module

This section provides specifications for the 24-port 10/100/1000BASE-T module (3C17516).

Specifications The 3C17516 module provides 24 10/100/1000BASE-T (RJ45) ports.

Table 34 3C17516 module specifications

Item	Specification
CPU	MPC8245
Boot ROM	512 KB
SDRAM	128 MB/256 MB
Physical dimensions (W x D)	366.7 x 340 mm (14.4 x 13.4 in.)
Max power consumption	110 W
Number of ports	24
Connector	RJ-45
Rate	10/100/1000 Mbps

Panel and LEDs **Figure 16** 3C17516 module panel

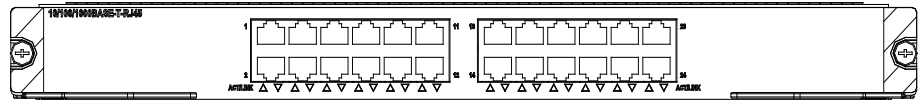

The 3C17516 module has one LED for each port on its panel.

Table 35 Port LEDs on the 3C17516 module

LED	Status	Meaning
LINK/ACT	ON	No link is present.
	OFF	A link is present.
	Blinking	Packets are being transmitted/received on the port.

3C17525 1-port 10GBASE-X Advanced (XENPAK) Module

This section provides specifications for the 1-port 10GBASE-X (XENPAK) Advanced module (3C17525).

Specifications The 3C17525 module provides one 10GE XENPAK/SC optical/electrical port.

Table 36 3C17511 module specifications

Item	Specification
CPU	MPC8245
Boot ROM	512 KB
SDRAM	128 MB/256 MB
Physical dimensions (W x D)	366.7 x 340 mm(14.4 x 13.4 in.)
Max power consumption	45 W
Number of ports	One
Connector	XENPAK/SC
Rate	10 Gbps

Panel and LEDs **Figure 17** 3C17525 module panel

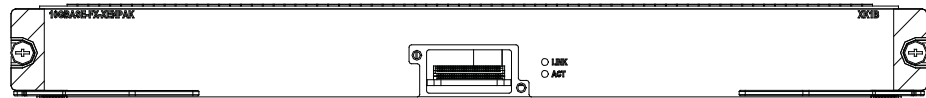

The 3C17525 module has two port LEDs for the 10GE port on its panel.

Table 37 Port LEDs on the 3C17525 module

LED	Status	Meaning
LINK	OFF	No link is present.
	Green ON	A link is present.
ACT	OFF	No packets are transmitted/received on the port.
	Orange blinking	Packets are being transmitted/received on the port.

Matching Cable See Table 66 on page 46 for the XENPAK optical modules available for the 10GE XENPAK/SC optical/electrical port on the 3C17525 module and their matching cable types, which you can select as required.

3C17526 4-port 10GBASE-X (XFP) Module

This section provides specifications for the 4-port 10GBASE-X (XFP) module (3C17526).

Specifications The 3C17526 module provides four 10GBASE-X (XFP) ports.

Table 38 3C17526 module specifications

Item	Specification
CPU	MPC8245
Boot ROM	512 KB
SDRAM	128 MB/256 MB
Physical dimensions (W x D)	366.7 x 340 mm (14.4 x 13.4 in.)
Number of ports	Four
Max power consumption	160 W

Table 38 3C17526 module specifications

Item	Specification
Connector	XFP
Rate	10 Gbps

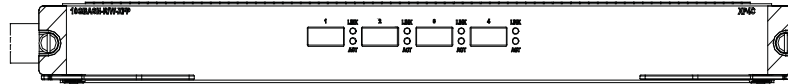
Panel and LEDs **Figure 18** 3C17526 module panel

The 3C17526 module has two LEDs for each optical port on its panel.

Table 39 1000 Mbps optical port LEDs on the 3C17526 module

LED	Status	Meaning
LINK	OFF	No link is present.
	Green	A link is present.
ACT	OFF	No packets are transmitted/received on the port.
	Orange blinking	Packets are being transmitted/received on the port.

Matching Cable For details about XFP optical modules available to the XFP optical ports on the 3C17526 module and their matching cable types, see Table 66 on page 46.

3C17527 2-port 10GBASE-X (XFP) Advanced Module

This section provides specifications for the 2-port 10GBASE-X (XFP) Advanced module (3C17527).

Specifications The 3C17527 module provide two 10GBASE-X XFP/LC ports.

Table 40 3C17527 module specifications

Item	Specification
CPU	MPC8245
Boot ROM	512 KB
SDRAM	128 MB/256MB
Physical dimensions (W x D)	366.7 x 340 mm (14.4 x 13.4 in.)
Max power consumption	87 W
Number of ports	Two
Connector	XFP
Rate	10 Gbps

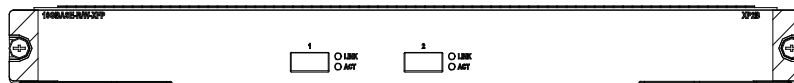
Panel and LEDs **Figure 19** 3C17527 module panel

The 3C17527 module has two LEDs for each optical port on its panel.

Table 41 1000 Mbps optical port LEDs on the 3C17527 module

LED	Status	Meaning
LINK	OFF	No link is present.
	Green	A link is present.
ACT	OFF	No packets are transmitted/received on the port.
	Orange blinking	Packets are being transmitted/received on the port.

Matching Cable See Table 66 on page 46 for the XFP optical modules that are available for the 10 Gbps XFP optical ports on the 3C17527 module and their matching cable types, which you can select as required.

3C17528 48port 10/100/1000 BASE-T (RJ-45) Module

This section provides specifications for the 48-port 10/100/1000 BASE-T (RJ-45) module (3C17528).

Specifications The 3C17528 module provides 48 10/100/1000 BASE-T auto-sensing PoE-capable RJ-45 ports.

Table 42 3C17528 module specifications

Item	Specification
CPU	MPC8245
BootROM	512 KB
SDRAM	128 MB
Physical dimensions (W x D)	366.7 x 340 mm (14.4 x 13.4 in.)
Number of ports	48
Connector	RJ-45
Rate	10/100/1000 Mbps

Panel and LEDs **Figure 20** 3C17528 module panel

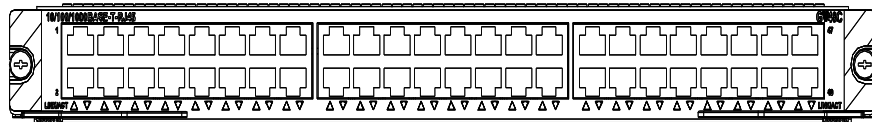

The 3C17528 module has one LED for each port on its panel.

Table 43 1000 Mbps electrical port LEDs on the 3C17528 module

LED	Status	Meaning
LINK/ACT	ON	A link is present.
	OFF	No link is present.
	Blinking	Packets are being transmitted/received on the port.

3C17530 24-port 1000BASE-X (SFP) Advanced Module

This section provides specifications for the 24-port 1000BASE-X (SFP) Advanced module (3C17530).

Specifications The 3C17530 Advanced Module provide 24 1000BASE-X (SFP) ports.

Table 44 3C17530 module specifications

Item	Specification
CPU	MPC8245
Boot ROM	512 KB
SDRAM	128 MB/256 MB
Physical dimensions (W x D)	366.7 x 340 mm (14.4 x 13.4 in.)
Max power consumption	100 W
Number of ports	24
Connector	SFP/LC
Rate	1.25 Gbps

Panel and LEDs **Figure 21** 3C17530 module panel

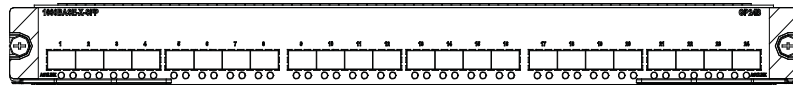

The 3C17530 module has two LEDs for each 1000 Mbps optical port on its panel.

Table 45 Port LEDs on the 3C17530 module

LED	Status	Meaning
LINK	OFF	No link is present.
	Green	A link is present.
ACT	OFF	No packets are transmitted/received on the port.
	Orange blinking	Packets are being transmitted/received on the port.

Matching Cable You can select appropriate SFP optical modules for the 1000 Mbps SFP optical ports on the 3C17530 module according to your needs. For a description of SFP the optical modules available for the SFP optical ports and their matching cable types, see Table 66 on page 46.

3C17531 24-port 10/100/1000BASE-T Advanced Module

This section provides specifications for the 24-port 10/100/1000BASE-T module (3C17531).

Specifications The 3C17531 module provides 24 10/100/1000BASE-T (RJ45) ports.

Table 46 3C17531 module specifications

Item	Specification
CPU	MPC8245

Table 46 3C17531 module specifications

Item	Specification
Boot ROM	512 KB
SDRAM	128 MB/256 MB
Physical dimensions (W x D)	366.7 x 340 mm (14.4 x 13.4 in.)
Max power consumption	110 W
Number of ports	24
Connector	RJ-45
Rate	10/100/1000 Mbps

Panel and LEDs **Figure 22** 3C17531 module panel

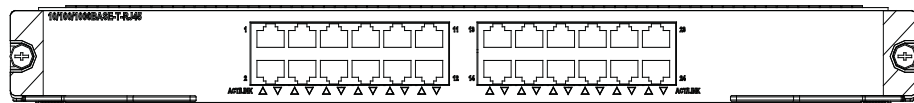

The 3C17531 module has one LED for each port on its panel.

Table 47 Port LEDs on the 3C17531 module

LED	Status	Meaning
LINK/ACT	ON	No link is present.
	OFF	A link is present.
	Blinking	Packets are being transmitted/received on the port.

3C17532 48-port 10/100/1000 BASE-T (RJ-45) Access Module

This section provides specifications for the 48-port 10/100/1000 BASE-T (RJ-45) Access module (3C17532).

Specifications

The 3C17532 module provides 48 10/100/1000 BASE-T auto-sensing PoE-capable RJ-45 ports.

Table 48 3C17532 module specifications

Item	Specification
CPU	MPC8245
BootROM	512 KB
SDRAM	128 MB
Physical dimensions (W x D)	366.7 x 340 mm (14.4 x 13.4 in.)
Number of ports	48
Connector	RJ-45
Rate	10/100/1000 Mbps

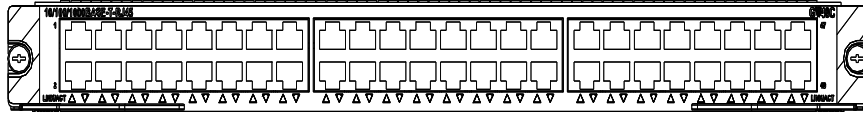
Panel and LEDs Figure 23 3C17532 module panel

The 3C17532 module has one LED for each port on their panel.

Table 49 1000 Mbps electrical port LEDs on the 3C17532 module

LED	Status	Meaning
LINK/ACT	ON	A link is present.
	OFF	No link is present.
	Blinking	Packets are being transmitted/received on the port.

3C17533 24-port 1000BASE-X (SFP) IPv6 Module

This section provides specifications for the 24-port 1000BASE-X (SFP) IPv6 module (3C17533).

Specifications The 3C17533 IPv6 module provides 24 1000BASE-X (SFP) ports.

Table 50 3C17533 module specifications

Item	Specification
CPU	MPC8245
Boot ROM	512 KB
SDRAM	128 MB/256 MB
Physical dimensions (W x D)	366.7 x 340 mm (14.4 x 13.4 in.)
Max power consumption	100 W
Number of ports	24
Connector	SFP/LC
Rate	1.25 Gbps

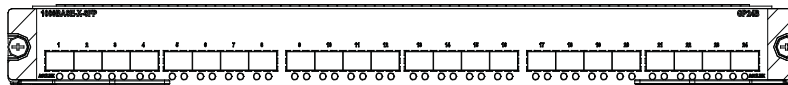
Panel and LEDs Figure 24 3C17533 module panel.

The 3C17533 module has two LEDs for each 1000 Mbps optical port on its panel.

Table 51 Port LEDs on the 3C17533 module

LED	Status	Meaning
LINK	OFF	No link is present.
	Green	A link is present.
ACT	OFF	No packets are transmitted/received on the port.
	Orange blinking	Packets are being transmitted/received on the port.

Matching Cable You can select appropriate SFP optical modules for the 1000 Mbps SFP optical ports on the 3C17533 module according to your needs. For a description of SFP the optical modules available for the SFP optical ports and their matching cable types, see Table 66 on page 46.

3C17534 24-port 10/100/1000BASE-T IPv6 Module

This section provides specifications for the 24-port 10/100/1000BASE-T IPv6 module (3C17534).

Specifications The 3C17534 module provides 24 10/100/1000BASE-T (RJ45) ports.

Table 52 3C17534 module specifications

Item	Specification
CPU	MPC8245
Boot ROM	512 KB
SDRAM	128 MB/256 MB
Physical dimensions (W x D)	366.7 x 340 mm (14.4 x 13.4 in.)
Max power consumption	110 W
Number of ports	24
Connector	RJ-45
Rate	10/100/1000 Mbps

Panel and LEDs The 3C17534 module has one LED for each port on its panel.

Figure 25 3C17534 module panel

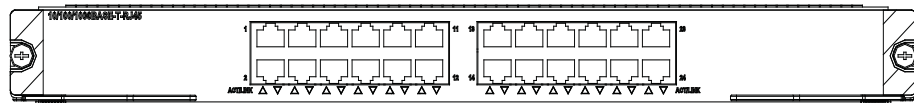

Table 53 Port LEDs on the 3C17534 module

LED	Status	Meaning
LINK/ACT	ON	No link is present.
	OFF	A link is present.
	Blinking	Packets are being transmitted/received on the port.

3C17536 4-port 10GBASE-X (XFP) QUAD IPv6 Module

This section provides specifications for the 4-port 10GBASE-X (XFP) QUAD IPv6 module (3C17536).

Specifications The 3C17536 module provides four 10GBASE-X (XFP) ports.

Table 54 3C17536 module specifications

Item	Specification
CPU	MPC8245

Table 54 3C17536 module specifications

Item	Specification
Boot ROM	512 KB
SDRAM	128 MB/256 MB
Physical dimensions (W x D)	366.7 x 340 mm (14.4 x 13.4 in.)
Number of ports	Four
Max power consumption (with bottom plate)	160 W
Connector	XFP
Rate	10 Gbps

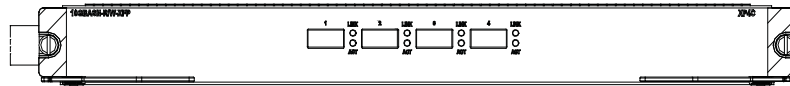
Panel and LEDs **Figure 26** 3C17536 module panel

The 3C17536 module has two LEDs for each optical port on its panel.

Table 55 1000 Mbps optical port LEDs on the 3C17536 module

LED	Status	Meaning
LINK	OFF	No link is present.
	Green	A link is present.
ACT	OFF	No packets are transmitted/received on the port.
	Orange blinking	Packets are being transmitted/received on the port.

Matching Cable For details about XFP optical modules available to the XFP optical ports on the 3C17536 module and their matching cable types, see Table 66 on page 46.

3C17537 2-port 10GBASE-X (XFP) IPv6 Module

This section provides specifications for the 2-port 10GBASE-X (XFP) IPv6 module (3C17537).

Specifications The 3C17537 modules provide two 10GBASE-X XFP/LC ports.

Table 56 3C17537 module specifications

Item	Specification
CPU	MPC8245
Boot ROM	512 KB
SDRAM	128 MB/256MB
Physical dimensions (W x D)	366.7 x 340 mm (14.4 x 13.4 in.)
Max power consumption	87 W
Number of ports	Two
Connector	XFP
Rate	10 Gbps

Panel and LEDs **Figure 27** 3C17537 module panel

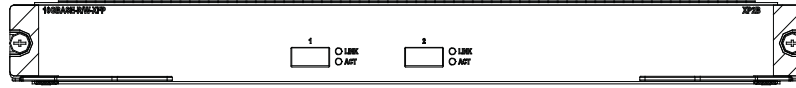

The 3C17537 module has two LEDs for each optical port on its panel.

Table 57 1000 Mbps optical port LEDs on the 3C17537 module

LED	Status	Meaning
LINK	OFF	No link is present.
	Green	A link is present.
ACT	OFF	No packets are transmitted/received on the port.
	Orange blinking	Packets are being transmitted/received on the port.

Matching Cable See Table 66 on page 46 for the XFP optical modules available for the 10 Gbps XFP optical ports on the 3C17537 module and their matching cable types, which you can select as required.

3C17538 48-port 1000BASE-X (SFP) IPv6 Module

This section provides specifications for the 48-port 1000BASE-X (SFP) IPv6 module (3C17538).

Specifications The 3C17538 module provides 48 1000BASE-X (SFP) ports.

Table 58 3C17538 module specifications

Item	Specification
CPU	MPC8245
BootROM	512 KB
SDRAM	128 MB/256 MB
Physical dimensions (W x D)	366.7 x 340 mm (14.4 x 13.4 in.)
Max power consumption	100 W
Number of ports	48
Connector	SFP/LC
Rate	1000 Mbps

Panel and LEDs **Figure 28** 3C17538 module panel



The 3C17538 module has one LED for each 1000 Mbps optical port on its panel.

Table 59 Port LEDs on the 3C17538 module

LED	Status	Meaning
LINK/ACT	Solid on	A link is present.
	Solid off	No link is present.
	Blinking	The port is transmitting or receiving data.

Matching Cable You can select appropriate SFP optical modules for the 1000 Mbps SFP/LC optical ports on the 3C17538 module accordingly to your needs. See Table 66 on page 46 for the available SFP optical modules and their matching cable types.

Application Modules

Each Application Module is specially designed for high-speed processing of a certain network service and shares some features with the I/O Modules.

Currently, the following application module are available to the Switch 8800 Family:

- 3C17542: Network Monitoring Application Module
- 3C17546: Firewall Application Module
- 3C1754766: Network Monitoring Application Module
- 3C17548: VPLS Application Module

3C17542 Network Monitoring Application Module

Technical specifications

The 3C17542 Network Monitoring Application Module provides no I/O ports.

Table 60 Technical specifications for the 3C17542

Item	Specifications
CPU	MPC755
Boot ROM	512 KB
SDRAM	256 MB
Physical dimensions (W x D)	366.7 x 340 mm (14.4 x 13.4 in.)

Front panel

Figure 29 Front panel of the 3C17542

3C17546 Firewall Application Module

Technical specifications

The 3C17546 Firewall Application Module provides eight Gigabit SFP/LC optical ports.

Table 61 Technical specifications for the 3C17546

Item	Specifications
CPU	BCM1250
Boot ROM	512 KB
SDRAM	1 Gbps
Physical dimensions (W x D)	366.7 x 340 mm (14.4 x 13.4 in.)

Front panel

Figure 30 Front panel of the 3C17546

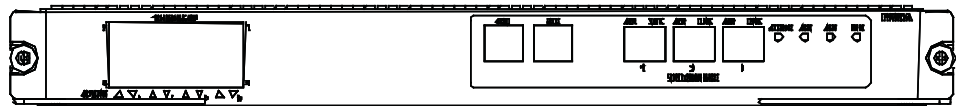

The 3C17546 provides eight 1000Base-X ports, one Console port, one AUX port, three 10/100Base-TX ports and four status LEDs (ATTACK, ACT, ALM and RUN) from left to right on the front panel.

Table 62 Status LEDs on the 3C17546

LED	Color	Status	Meaning
ATTACK	Red	OFF	The module is not attacked.
		ON	The module is attacked.
ACT	Green	OFF	The module is in standby mode.
		Blinking	The module is in active mode.
ALM	Red	OFF	There is no link alarm.
		ON	There is a link alarm.
RUN	Green	OFF	The module is faulty.
		Blinking	The module operates normally.

Available cables

Table 66 on page 46 lists the available SFP modules and cable types for the 1000BASE-X SFP ports.

3CR1754766 IPsec Module

Technical specifications

The 3CR1754766 IPsec Module provides eight Gigabit SFP optical ports.

Table 63 Technical specifications for the 3CR1754766

Item	Specifications
CPU	BCM1250
Boot ROM	512 KB

Table 63 Technical specifications for the 3CR1754766

Item	Specifications
SDRAM	512 MB
Physical dimensions (W x D)	366.7 x 340 mm (14.4 x 13.4 in.)

Front panel

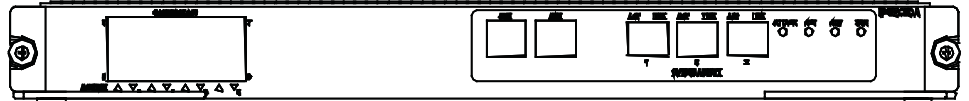
Figure 31 Front panel of the 3CR1754766

The 3CR1754766 provides eight 1000Base-X ports, one Console port, one AUX port, three 10/100Base-TX ports and four status LEDs (ATTACK, ACT, ALM and RUN) from left to right on the front panel.

Table 64 Status LEDs on the 3CR1754766

LED	Color	Status	Meaning
ATTACK	Red	OFF	The module is not attacked.
		ON	The module is attacked.
ACT	Green	OFF	The module is in standby mode.
		Blinking	The module is in active mode.
ALM	Red	OFF	There is no link alarm.
		ON	There is a link alarm.
RUN	Green	OFF	The module is faulty.
		Blinking	The module operates normally.

Available cables

Table 66 on page 46 lists the available SFP modules and cable types for the 1000BASE-X SFP ports.

3C17548 VPLS Application Module

Technical specifications

The 3C17548 Virtual Private LAN Service (VPLS) Application Module provides no I/O ports.

Table 65 Technical specifications for the 3C17548

Item	Specifications
CPU	MPC755
Boot ROM	512 KB
SDRAM	512 MB
Physical dimensions (W x D)	366.7 x 340 mm (14.4 x 13.4 in.)

Front panel

Figure 32 Front panel of the 3C17548



Transceivers

Table 66 documents the 3Com Switch 8800 Family transceivers.

Table 66 Transceiver Specifications

3Com Transceiver Name	Ordering Number	Cable Type	Core Size (microns)	Model Bandwidth (MHz - Km)	Transmission Range	Wavelength (nm)	Optical Power Range (dBm)			Connector
							Output	Input		
XENPAKs										
3Com 10GBASE-LR XENPAK	3CXENPAK92	SMF	9	–	2 m – 10 km (6.6 ft – 6 mi)	1,300	-8.2 to 0.5	-14.4 to 0.5		SC
3Com 10GBASE-SR XENPAK	3CXENPAK94	MMF	50	2,000	2 m – 300 m (3.2 ft – 990 ft)	850	-7.3 to -1.3	-11.1 to -1.0		LC
3Com 10GBASE-ER XENPAK	3CXENPAK96	SMF	9	–	2 m – 40 km (6.6 ft – 25 mi)	1,550	-4.7 to 4	-15.8 to -1		SC
XFPs										
3Com 10GBASE-LR XFP	3CXFP92	SMF	9	–	2 m – 10 km (6.6 ft – 6 mi)	1,300	-8.2 to 0.5	-14.4 to 0.5		LC
3Com 10GBASE-SR XFP	3CXFP94	MMF	62.5	160	0.5 – 26 m (1.7 – 85 ft)	850	-4.0 to -1.1	-9.9 to -1.0		LC
		MMF	62.5	200	0.5 – 33 m (1.7 – 108 ft)					
		MMF	50	400	0.5 – 66 m (1.7 – 217 ft)					
		MMF	50	500	0.5 – 100 m (1.7 – 328 ft)					
MMF	50	2,000	0.5 – 300 m (1.7 – 984 ft)							
3Com 10GBASE-ER XFP	3CXFP96	SMF	9	–	2 m – 40 km (6.6 ft – 25 mi)	1,550	-4.7 to 4	-15.8 to -1		LC
1000 Mbps SFPs										
3Com 1000BASE-SX SFP	3CSFP91	MMF	62.5	160	2 – 220 m (6.6 – 721 ft)	850	-9.5 to 0	-17 to 0		LC
		MMF	62.5	200	2 – 275 m (6.6 – 902 ft)					
		MMF	50	400	2 – 500 m (6.6 – 1,640 ft)					
		MMF	50	500	2 – 550 m (6.6 – 1,804 ft)					
3Com 1000BASE-LX SFP	3CSFP92	MMF	62.5	500	2 – 550 m (6.6 – 1,804 ft)	1,300	-9.5 to -3	-20 to -3		LC
		MMF	50	400	2 – 550 m (6.6 – 1,804 ft)					
		MMF	50	500	2 – 550 m (6.6 – 1,804 ft)					
		SMF	9	–	2 m – 10 km (6.6 ft – 6 mi)					
3Com 1000BASE-LH70 SFP	3CSFP97	SMF	9	–	2 m – 70 km (6.6 ft – 43 mi) ft	1,550	0 to 3	-24 to -3		LC
3Com 1000BASE-T SFP	3CSFP93	CAT5	–	–	100 m (328 ft)	–	–	–		RJ-45

Switch 8800 Port Densities

Table 67 describes the modules that are available for the Switch 8800, their maximum port densities, and whether or not the module supports MPLS or IPv6.

Table 67 Switch 8800 Available Modules

SKU	Description	Max Port Density*	MPLS	IPv6	Fabric Adapters
3C17511	1-port 10GBASE-X (XENPAK)	12	No	No	1
3C17512	2-port 10GBASE-X (XFP)	24	No	No	2
3C17513	12-port 1000BASE-X (SFP)	144	No	No	1
3C17514	24-port 1000BASE-X (SFP)	288	No	No	2
3C17516	24-port 10/100/1000BASE-T (RJ-45)	288	No	No	2
3C17525	1-port 10GBASE-X (XENPAK) Advanced	12	Yes	No	1
3C17526	4-port 10GBASE-X (XFP)	48	No	No	2
3C17527	2-port 10GBASE-X (XFP) Advanced	24	Yes	No	2
3C17528	48-port 10/100/1000 BASE-T (RJ-45)	576	No	Yes**	1
3C17530	24-port 1000BASE-X (SFP) Advanced	288	Yes	No	2
3C17531	24-port 10/100/1000BASE-T (RJ45) Advanced	288	Yes	No	2
3C17532	48-port 10/100/1000BASE-T (RJ45) Access	576	No	Yes**	1
3C17533	24-port 1000BASE-X (SFP) IPv6 Module	288	No	Yes**	2
3C17534	24-port 10/100/1000BASE-T (RJ-45) IPv6 Module	288	No	Yes**	2
3C17536	4-port 10GBASE-X (XFP) QUAD IPv6	48	No	Yes**	4
3C17537	2-port 10GBASE-X (XFP) IPv6	24	No	Yes	2
3C17538	48-port 1000BASE-X (SFP) IPv6	576	No	Yes**	1
3C17542	Network Monitoring Module		No	No	1
3C17546	Firewall Module	8	No	No***	1
3CR1754766	IPsec Module	8	No	No***	1
3C17548	Virtual Private LAN Service (VPLS)		No	No	1

*Maximum port densities stated for largest chassis model, the Switch 8814 (14 slots)

**IPv6 capable hardware module; advanced software upgrade required for IPv6 routing.

*** The Firewall, IPsec, and VPLS Modules do not support IPv6 in the first IPv6 release.

3

INSTALLATION PREPARATION

Safety Recommendations

To avoid possible bodily injury and device impairment, please read the following safety recommendations carefully before installing the Switch 8800 Family. The recommendations do not cover every possible hazardous condition.

General Safety Recommendations

- The Switch 8800 Family use redundant PSUs. Turn off all PSUs and remove all the power cords before opening the chassis.
- Keep the chassis clean and dust-free.
- Keep the chassis and installation tools away from walk areas.

Safety Recommendations against Electricity

- Look carefully for possible hazards in your work area, such as ungrounded power extension cables, missing safety grounds, and moist floors.
- Locate the emergency power-off switch in the room before installation. Shut the power off at once in case accident occurs.
- Unplug all the power cords and external cables before moving the chassis.
- Do not maintain the equipment alone when it has been powered.
- Never assume but check each time that power has been disconnected from a circuit.
- Do not place the switch on a moist area and avoid liquid flowing into the switch.

Safety Recommendations in Moving the Switch 8800 Family

The Switch 8800 Family are rather big and heavy, so follow the recommendations below when moving it.

- Remove all the external cables (including power cords) before moving the chassis.
- Do not move the switch alone. Work with another person.
- Move the switch slowly and stably. Never move suddenly or twist your body.
- Move the switch at stable and consistent paces with your peer. Keep balance of your body.



CAUTION: *You can only hold the handles at both sides of the chassis when moving the switch, but not the plastic panel of the chassis, the handle of the fan frame, the handle of the PSUs or the air vents of chassis.*

As these parts are not designed for bearing the weight of the entire chassis, any attempt trying to carry the switch with these parts may impair the switch and even injure yourself.

Wearing an ESD-Preventive Wrist Strap

To prevent the electronic components from being damaged by the electrostatic discharge (ESD), take ESD measures for the area where the switch is located and note the issues below:

- Always wear an ESD-preventive wrist strap when installing the parts, especially the electric printed circuit boards.
- Hold the circuit board by the edge. Do not touch the components or the electric printed circuit.

Take the following steps to use the ESD-preventive wrist strap.

Step 1: Wear the wrist strap on your wrist.

Step 2: Lock the wrist strap tight around your wrist to keep good contact with the skin.

Step 3: Insert it into the hole peculiar to ESD-preventive wrist strap in the chassis or attach it to the grounding screw of the chassis the alligator clips.

Step 4: Make sure that the ESD-preventive wrist strap is well grounded.



CAUTION: For the sake of safety, check the resistance of the ESD-preventive wrist strap. The resistance reading should be in the range of 1 to 10 Mohm between human body and the ground.

Safety Recommendations against Laser

Some I/O modules of the Switch 8800 Family have optical interfaces. In operating status, it is dangerous to stare into the open optical interface because the laser being transmitted through the optical fiber produces a small beam of light which has very high power density and is invisible to human eyes; when a beam of light enters the eye, retina may be burned.



CAUTION: The laser inside the optical fiber may hurt your eyes.

Examining Installation Site

The Switch 8800 Family can only be used indoors. To ensure that the switch works normally and to prolong its service lifetime, the following requirements should be met in terms of installation environment.

Temperature/Humidity Requirements

To ensure the normal operation and service lifetime of a switch, proper temperature and humidity should be maintained in the equipment room. Long-lasting high humidity in the equipment room is prone to poor insulation or even leakage of the insulating material. Sometimes, the mechanical performance deterioration, the rustiness and corrosion of some metal parts are also more likely to occur. If the relative humidity is too low, the captive screws may become loose due to the insulation washer contraction. Meanwhile, the electrostatic is likely to be produced in the dry environment, which will jeopardize the CMOS circuit of the switch. The higher the temperature, the greater the damage it will do to the switch. Long-lasting high temperature will speed up the aging process of the insulating materials, greatly lower the reliability of the switch, and therefore affect its service life seriously.

Cleanness Requirements

Dust is a hazard to the operating safety of the switch. The indoor dust accumulated on the chassis can cause electrostatic absorption, which may result in the poor contact of the connector or metal contact point. This happens more frequently when indoor relative humidity is low, which will not only shorten the service life of the switch, but also cause communication failure.

The required specifications on dust content and particle diameter in an equipment room are shown in the following table.

Table 68 Limitation on dust content in equipment room

Mechanical active material	Unit	Content
Dust particle	particles/m ³	≤3 × 10 ⁴ (No visible dust on desk in three days)

Note: Dust particle diameter ≥ 5μm

Besides the dust specifications, the equipment room of the switch should also meet the rigorous requirements for the content of salt, acid and sulfide in the air. These harmful gases could accelerate the metal erosion and the aging process of some parts. Incursion of harmful gases, such as SO₂, H₂S, NO₂, NH₃, and Cl₂, should be prevented. The specific limitation values of these harmful gases are given in the following table.

Table 69 Harmful gas limits in an equipment room

Gas	Average (mg/m ³)	Max. (mg/m ³)
SO ₂	0.3	1.0
H ₂ S	0.1	0.5
NO ₂	0.004	0.15
NH ₃	1.0	3
Cl ₂	0.1	0.3

Anti-Static Requirements

Any possible interference sources, no matter outside or inside the system, affect the switch in use in a way of capacitive coupling, inductive coupling, electromagnetic radiation, common impedance (including the grounding system) coupling or conducting line (power line, signaling line and transmission line etc.). To prevent the interference, you should:

- Take effective measures against electrical net interference for power supply system.
- Separate the working ground of the switch from the grounding device of the power supply equipment or lightning-protection grounding device as far as possible.
- Keep the switch far away from the radio launcher, radar launcher, and high-frequency devices working in the high current.
- Adopt electromagnetic shielding if necessary.

Grounding Requirements

A good grounding system is not only the basis essential to the stable and reliable switch operation, but also an important guarantee of lightning protection, anti-interference and ESD-prevention. The user must provide good grounding system for the switch.

Power Supply Requirements

The Switch 8800 Family adopts redundant PSUs for AC PSU:

Rated voltage: 100 VAC to 240 VAC, 50 Hz or 60 Hz

Maximum tolerance: 90 VAC to 264 VAC, 50 Hz or 60 Hz

Maximum power output: 1200 W (Switch 8807)/2000 W (Switch 8810/Switch 8814)

Space Requirements

For the sake of adequate ventilation and easy equipment maintenance, you are recommended to keep one meter of clearance between the rear/front of the switch cabinet and the wall surface or other devices. If the optional cabinet is desired, the clear height of the equipment room must be more than 3 meters inclusive.

Cabinet-Mounting Requirements

Before cabinet-mounting the switch, make sure that the cabinet meets the following requirements:

- Better mount the switch in an open cabinet. However, if you want to mount it in a closed cabinet, make sure of the availability of a good ventilation system.
- Make sure that the cabinet stands steadily enough to support the weight of the switch and the accessories.
- Make sure that the switch fits the cabinet size. Leave some clearance beside the left and right panels of the switch for chassis ventilation.

Installation Tools**Table 70** Required installation tools

	Measure and lineation tools	Long tape, ruler (1 meter in length), marking pen, powder marker, pencil
	Drills	One percussion drill, several drill bits, one vacuum cleaner
		Flat-module screwdriver P4 -- 75 mm
		Phillips screwdriver P1 -- 100mm, P2 -- 150mm and P3 -- 250mm
General tools	Fastening tools	Socket wrench M5
		Box-end wrench M6
		Double ring spanner (10-12) or open-end wrench (10-12)
	Small tools	Sharp-nose pliers, diagonal pliers, vices, hand-held electric drill, file, handsaw, crowbar, rubber hammer
	Auxiliary tools	Brush, tweezers, paper knife, hand bellows, electric iron, solder wire, fork, ladder
	Special tools	ESD-preventive wrist strap, cable stripper, crimping pliers, RJ-45 crimping pliers, wire punchdown tool
	Meters	Multimeter, 500V Meg-ohmmeter (used for measuring the insulation resistance), error detector, optical power meter, earth resistance tester



The instruments and tools are not shipped with the Switch 8800 Family and it is up to the users to ensure their availability.

4

SWITCH INSTALLATION

The Switch 8800 Family shall be installed indoors in a fixed place.

Confirming Installation Preparation

- Make sure that you have read Chapter 3 Installation Preparation carefully.
- All requirements mentioned in Chapter 3 Installation Preparation have been met.

Installation Flow

Figure 33 Installation Flow

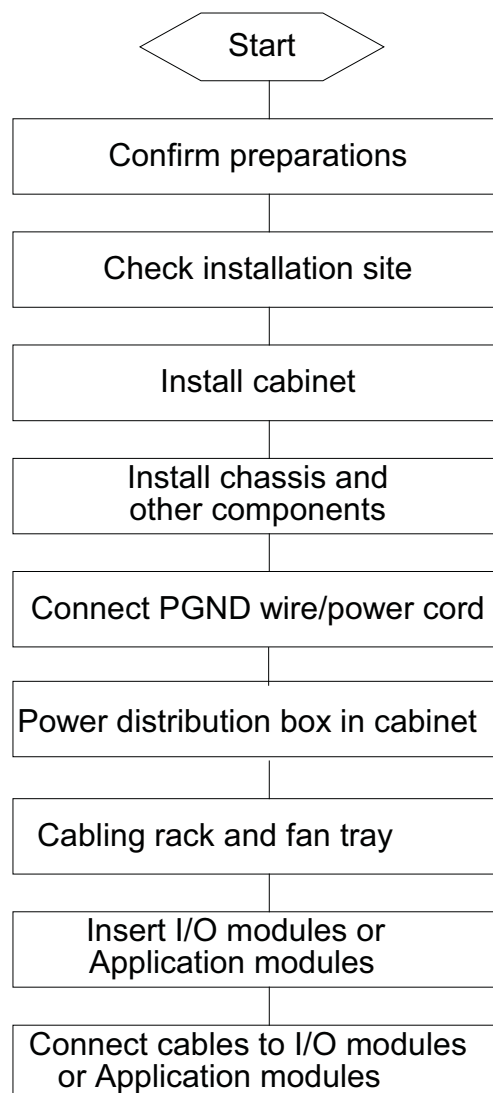

Mounting the Switch in User-Supplied Cabinet

Cabinet Configuration Guideline

**CAUTION:**

- Even if no PoE external power supply is installed, it is recommended that you reserve the PoE power supply slot (just cover a 4 U blank filler panel) in the cabinet for later PoE expansion.
- For components of 4 U or higher, such as chassis and PoE power supply, more screws are required to secure the slide rails in the cabinet considering their weight.
- You can adjust the specific height of every slot as needed. The following guideline is just for reference.

One Switch 8807 chassis in a cabinet

The components and their height are as follows (from bottom up):

- Blank filler panel (2U)
- Cabling frame (2U)
- External PoE power supply (or blank filler panel if no external PoE power supply is installed) (4U)
- Blank filler panel (1U)
- Back cabling frame (1U)
- New Switch 8807 chassis (11U)
- Blank filler panel (1U)
- Cabling frame (2U)

Figure 34 One Switch 8807 chassis in a cabinet

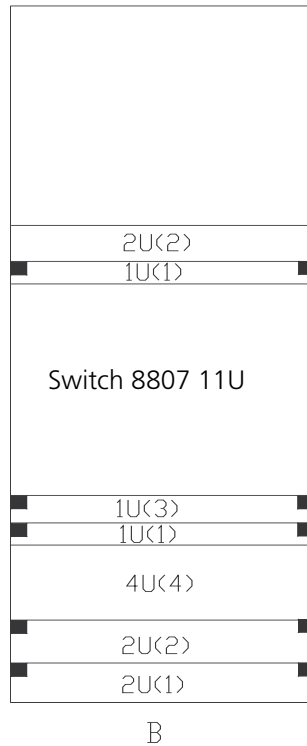

- | | |
|----------------------------|--|
| (1) Blank filler panel | (2) Cabling frame |
| (3) Backward cabling frame | (4) Reserved for external PoE power supply |

Guideline: The space marked in Figure 34 must be reserved, and the remaining is at your disposal.

Two Switch 8807 chassis in a cabinet

The components and their height are as follows (from bottom up):

- Blank filler panel (2U)
- Cabling frame (2U)
- External PoE power supply (or blank filler panel if no external PoE power supply is installed) (4U)
- Blank filler panel (1U)
- Back cabling frame (1U)
- Switch 8807 chassis (11U)
- Blank filler panel (1U)
- Cabling frame (2U)
- Switch 8807 chassis (11U)

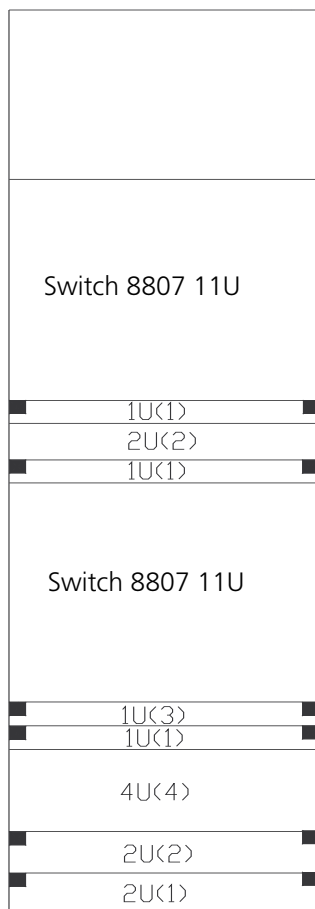
Figure 35 Two Switch 8807 chassis in a cabinet

(1) Blank filler panel
 (3) Backward cabling frame

(2) Cabling frame
 (4) Reserved for external PoE power supply

Guideline: The space marked in Figure 35 must be reserved, and the remaining is at your disposal.

One Switch 8810 chassis in a cabinet

The components and their height are as follows (from bottom up):

- Blank filler panel (2U)
- Cabling frame (2U)
- External PoE power supply (or blank filler panel if no external PoE power supply is installed) (4U)
- Blank filler panel (1U)
- Back cabling frame (1U)
- Switch 8810 chassis (14U)
- Blank filler panel (1U)
- Cabling frame (2U)

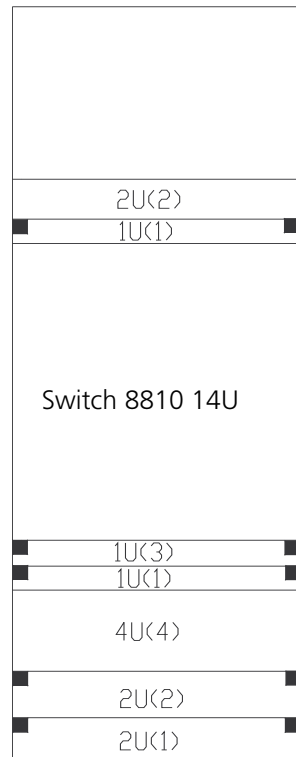
Figure 36 One Switch 8810 chassis in a cabinet

(1) Blank filler panel

(2) Cabling frame

(3) Backward cabling frame

(4) Reserved for external PoE power supply

Guideline: The space marked in Figure 36 must be reserved, and the remaining is at your disposal.

One Switch 8814 chassis in a cabinet

The components and their height are as follows (from top down):

- Blank filler panel (2U)
- Cabling frame (2U)
- External PoE power supply (or blank filler panel if no external PoE power supply is installed) (4U)
- Blank filler panel (1U)
- Back cabling frame (1U)
- Switch 8814 chassis (17U)
- Blank filler panel (1U)
- Cabling frame (2U)

Figure 37 One Switch 8814 chassis in a cabinet

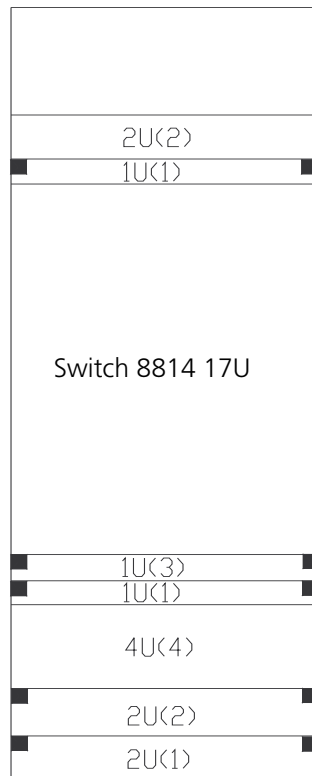

- (1) Blank filler panel
- (2) Cabling frame
- (3) Backward cabling frame
- (4) Reserved for external PoE power supply

Guideline: The space marked in Figure 37 must be reserved, and the remaining is at your disposal.

Mounting the Switch in the Cabinet

Take the following steps to install the Switch 8800 Family in a 19-inch cabinet.

Step 1: Confirm before installation

- Make sure that the cabinet has been well fixed. The layout inside the cabinet for switch installation has been well done and there is no obstruction inside or around the cabinet.
- Make sure that the switch is ready for installation and has been carried to a place convenient for further moving near the cabinet.

Step 2: Mount a shelf inside the cabinet depending on the position where you want to put the switch.

Step 3: Install the cabling rack and attach the mounting ears shipped with the switch onto the switch.

Step 4: Carry the switch at both sides with another person to the place in front of the cabinet slowly.

Step 5: Lift the switch a little higher than the cabinet shelf, put it on the shelf, and push it into the cabinet.

Step 6: Align the mounting ears with the square holes in the posts of the cabinet, and fasten the screws in the holes to fix the switch in the cabinet.

Connecting PGND Wire and Power Cord

Connecting PGND Wire



CAUTION: For the safety of operators and equipment, the switch must be well grounded. The resistance reading between switch chassis and the ground must be less than 1 ohm.

Common grounding environment

Step 1: Remove the screw from the grounding hole in the switch chassis.

Step 2: Wear the connector of the PGND wire accompanied with the switch on the grounding screw.

Step 3: Insert the grounding screw into the grounding hole and screw it down.

Step 4: Connect the other end of the ground wire to the ground bar of the switch.



Generally, the cabinets installed in equipment rooms are equipped with ground bar. In this case, you can connect the PGND wire of the switch to the ground bar for it.

Other grounding environment

Following are some methods for grounding the switch in different grounding environments that you are likely to encounter when installing the switch at different places.



Rather than specifying the switch model or showing the actual location of the switch power input or grounding screw, the following figures are primarily intended for illustrating the switch grounding, either via grounding screw or power input, in specific grounding environments.

- If a ground bar is available, attach one end of the yellow-green PGND wire of the switch to a grounding bolt of the ground bar and fasten the captive nuts. Note that the fire main and lightning rod of a building are not suitable for grounding the switch. The PGND wire of the switch should be connected to the grounding device in the equipment room. (For the Switch 8800 Family, the grounding screw is on the rear panel. Connect it as illustrated in Figure 38).

Figure 38 Ground the switch when ground bar is available

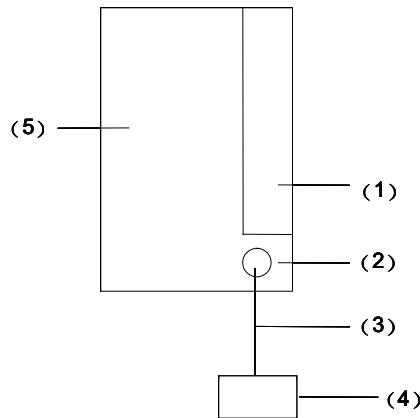

- (1) Air filter
- (2) Grounding screw
- (3) PGND wire
- (4) Ground bar of the equipment room
- (5) Rear panel of the switch

- If there is no ground bar but earth nearby and the grounding body is allowed to be buried, you can simply hammer an angle iron or steel pipe no shorter than 0.5 m into the earth. In this case, the yellow-green PGND wire should be welded with the angle iron (steel pipe) and the joint should be processed against eroding. (For the Switch 8800 Family, the grounding screw is on the rear panel. Connect it as illustrated in Figure 38).

Figure 39 Ground the switch when allowed to bury grounding body nearby

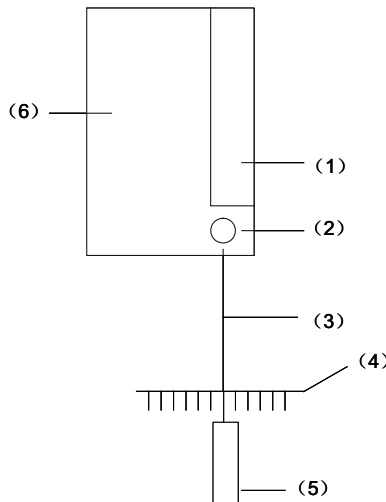

- (1) Air filter
- (2) Grounding screw
- (3) PGND wire
- (4) Ground bar of the equipment room
- (5) Angle steel
- (6) Rear panel of the switch

- If both ground bar and the conditions for burying the grounding body are not available, an AC-powered Ethernet switch can be grounded using the PE wire of the AC power supply. In this case, make sure that the PE wire of the AC

power supply has been well grounded at the power distribution room or AC power supply transformer side.

Figure 40 Ground the switch via AC PE wire

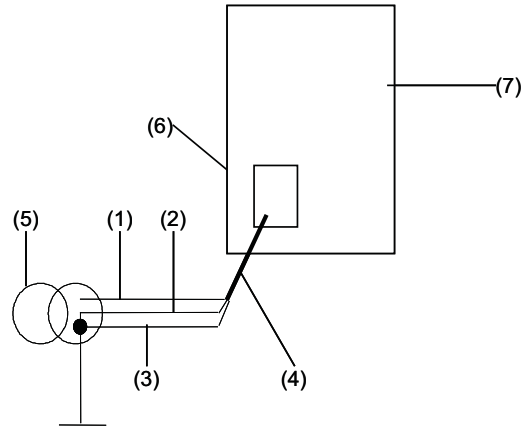

(1) Live line

(3) PE line

(5) Transformer

(7) Front panel of the switch

(2) Neutral line

(4) 3-core AC input cable

(6) AC power input

Connecting AC Power Cord



CAUTION:

- For lightning protection, the AC power should be led through an external lightning device into the switch.
- Make sure the power switch on the PSU is at OFF position before connecting the power cord.

On the front panel of AC PSU, there is a plug-retention clamp.

Take the following steps to connect the AC power cord (coming with the switch) to the Switch 8807/Switch 8810/Switch 8814:

Step 1: Turn the clamp at the left of the PSU front panel to the right.

Step 2: Insert the plug at one end of the AC power cord into the socket on the PSU.

Step 3: Turn the clamp to the left until it grips the plug.

Step 4: Insert the other end of the power cord into an external power socket.

Figure 41 Connect AC power cord to the Switch 8807

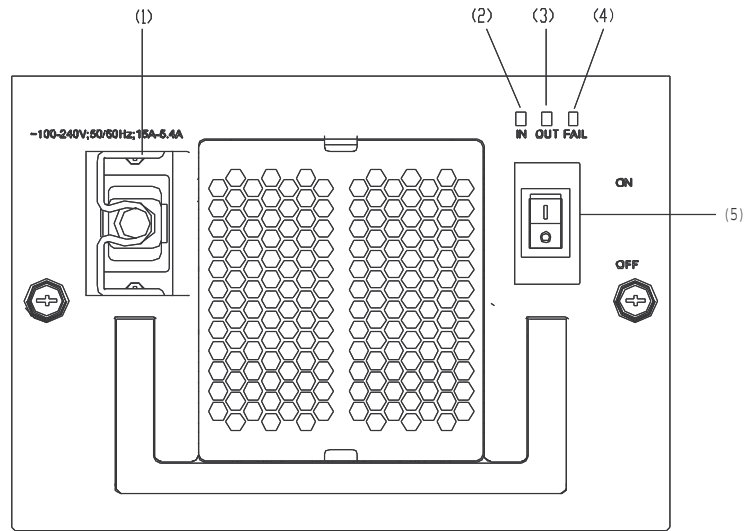

- (1) Connector-retention clamp
- (2) Input LED
- (3) Output LED
- (4) Fail LED
- (5) Power switch

Figure 42 Connect AC power cord to the Switch 8810/Switch 8814

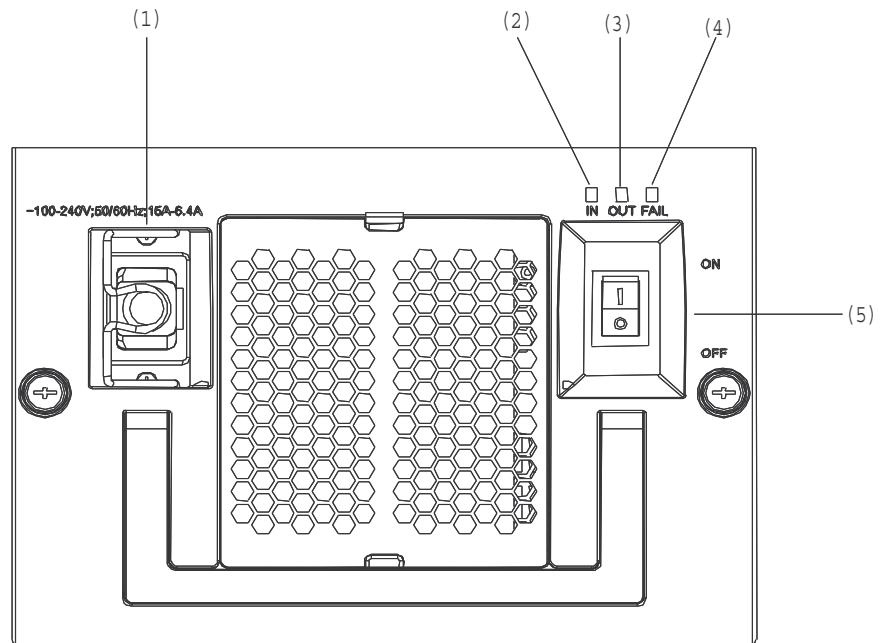

- (1) Connector-retention clamp
- (2) Input LED
- (3) Output LED
- (4) Fail LED
- (5) Power switch

Connecting PoE Power Cord

The Switch 8807/Switch 8810/Switch 8814 uses PSE4500-A external PoE power supply, which is connected to the switch through the PoE module at the front bottom of the switch to provide power to PDs (powered devices) under the switch.



This section only focuses on the cable connection between the external PoE power supply and the Switch 8800 Family switch. For the installation of the external PoE power supply, see the manual shipped with the power supply.

Grounding PoE chassis

You must ground the PoE chassis before connecting the PoE power cord to it. Follow these steps:

Connect the 6 AWG cable of the wiring terminal (with M6 hole) to the grounding screw on the rear panel of the switch, as shown in Figure 43.

Connect the other end of the cable to the grounding bar or other grounding terminals.

Figure 43 Ground PoE chassis

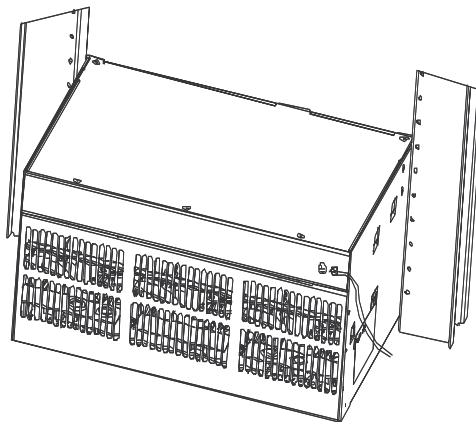

(1) Chassis grounding screw

Connecting PoE power cable

Loosen the mounting screw of the PoE entry module with a cross screwdriver.

Insert the -48V OT terminal (blue) of the DC power cord to the NEG (-) terminal of the PoE entry module and fasten the mounting screw; insert the other end to the NEG (-) terminal of the external PoE power supply.

Insert the GND OT terminal (black) of the DC power cord to the RTN (+) terminal of the PoE entry module and fasten the mounting screw; insert the other end to the NEG (-) terminal of the external power supply.



CAUTION:

- Observe the signs on devices and connect the cables correctly.
- Choose right cables based on the load.

Figure 44 Front panel of external PoE Power Rack (3C17509)

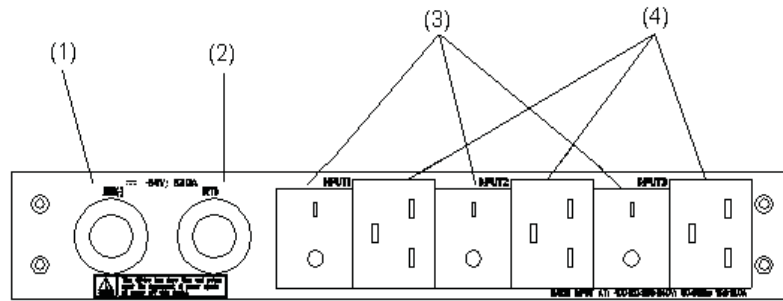

- (1) DC output terminal: NEG(-)
- (2) DC output terminal: RTN(+)
- (3) AC input switch
- (4) AC input socket

Installing Cabling Rack

For your convenience, cabling racks are shipped with the Switch 8800 Family. Take the following steps to install the rack.

Step 1: Face the I/O module slots of the switch;

Step 2: Attach the left mounting ear (the one with an elliptical hole on one surface and a recessed hole on the other) onto the cabling rack and fix it with screws (one cabling rack for Switch 8807/Switch 8810 and two for Switch 8814);

Step 3: Install mounting ears onto the both sides of the switch.

Figure 45 The position of the cabling rack

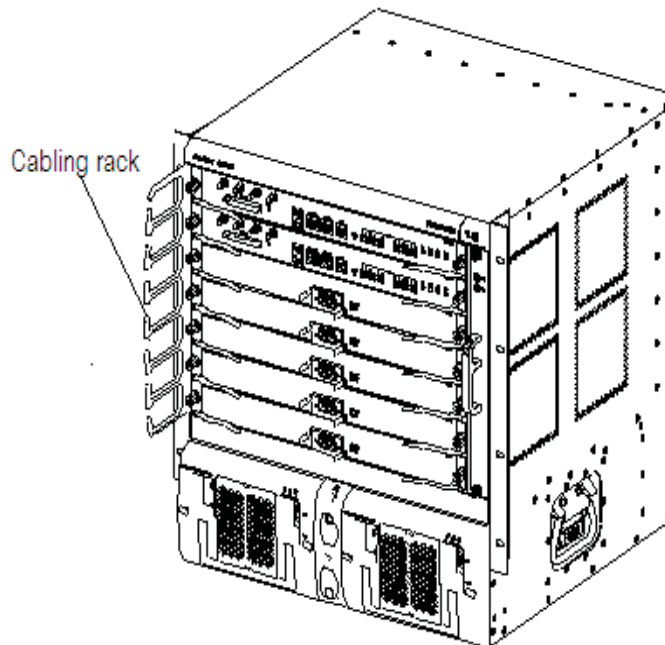

Installing Fan Tray

The fan tray is hot swappable.



CAUTION: In case of bodily injuries, do not touch any naked wire, terminal or other parts of the product with hazardous voltage labels.

Step 1: Wear the ESD-preventive wrist strap, making sure that it makes good skin contact; take the fan tray out from the packing bag.

Step 2: Hold the fan tray in right direction (just check the direction of instructional words, and if you insert it upside down, the plug of the fan tray cannot touch the right socket inside the chassis), with one hand on its handle and the other hand at its bottom the ejector levers on the fan tray with both hands and pull them outward. Align the fan tray with the guides in the chassis and slide it gently into the slot until its plug touches the chassis socket.

Step 3: Fasten the mounting screws on the panel of the fan tray with a screw driver.



The above installation steps are just for replacing your fan tray, since the fan tray is delivered together with the chassis and no initial installation is required.

Installing PoE Lightning Protection Box

The 3C17510 PoE Entry Module is hot-swappable.



CAUTION: Do not touch any exposed wires, terminals, and device parts marked as hazard to avoid hurting your body.

- 1 Wear an ESD-preventive wrist strap and ensure it is well grounded. Unpack the PoE lightning protection box, which is shown in Figure 46.

Figure 46 PoE Entry Module

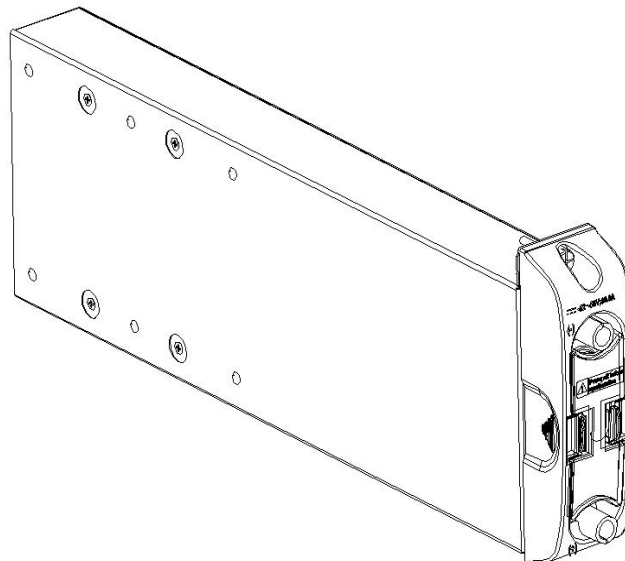

- 2 Keep the PoE Entry Module in the right direction, that is, correct letter direction (do not turn it upside down, or you will not be able to fully insert it into the chassis due to the limitation on the back structure of the box, nor can you fasten the chassis fixing screw), hold it with one hand at the bottom and with another hand

at the front panel, and then slide it smoothly along the guide rail to the slot, until it fits into the chassis, with its plug fully touching the socket inside the chassis. See Figure 47.

Figure 47 Install PoE lightning protection box

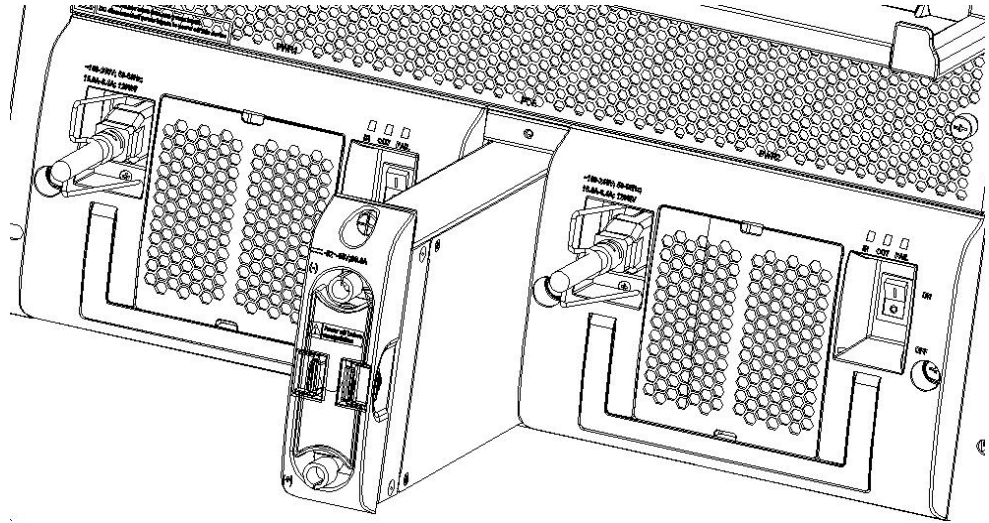

- 3 Fasten the screw on top of the PoE lightning protection box.



Generally, the PoE lightning protection box is shipped with the chassis of the switch you ordered. So you need not to install the box. The above installation procedure is needed only when you are changing the fan frame.

Installing I/O modules

The I/O modules of the Switch 8800 Family are hot-swappable.

Step 1: Wear the ESD-preventive wrist strap, making sure that you have grounded it well. Take the I/O module out of the packing bag.

Step 2: Unscrew the mounting screws holding the blank filler panel in the slot where you plan to install the I/O module, and remove the panel from the slot.

Step 3: Hold the ejector levers on the fan tray with both hands and pull them outward. Align the I/O module with the guides in the chassis and slide it gently into the slot until the positioning pin of the I/O module touches the hole in the chassis.

Step 4: Pull the ejector levers inward, locking the positioning pin into the hole.

Step 5: Fix the I/O module by fastening the mounting screws on the I/O module with a screw driver.



Put the removed blank filler panel away for future use.

For the Switch 8800 Family, the Application Module can be installed in the I/O module slot in the same way as installing the I/O module board.

Connecting Interface Cables

Connecting Console Cable

Introduction

Console cable is an 8-core shielded cable. At one end of the cable is a crimped RJ-45 connector that is to be plugged into the console port of the switch. At the other end of the cable are a DB-9 (female) connector and a DB-25 (female) connector. You can plug either of them into the 25-pin (male) or 9-pin (male) serial port on the console terminal as needed. The following figure illustrates the console cable.

Figure 48 Console cable

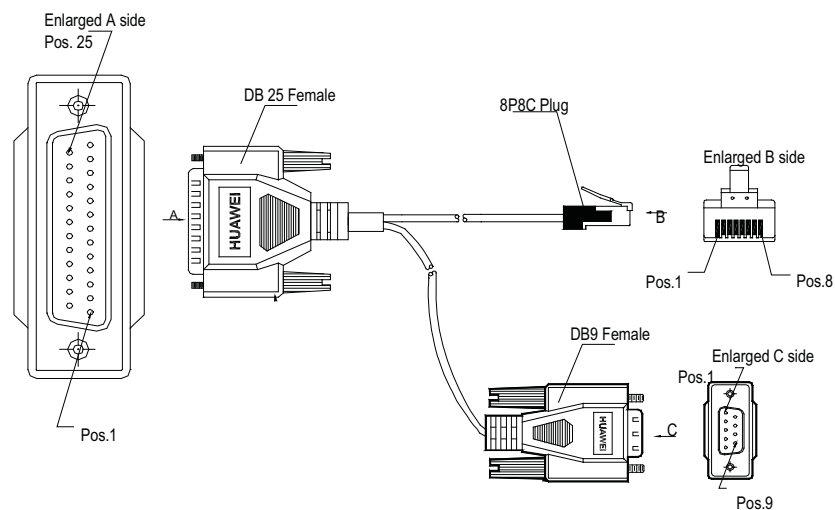

Table 71 Console cable pinouts

RJ-45	Signal	Direction	DB-25	DB-9
1	RTS	←	4	7
2	DTR	←	20	4
3	TXD	←	2	3
4	CD	→	8	1
5	GND	–	7	5
6	RXD	→	3	2
7	DSR	→	6	6
8	CTS	→	5	8

Connecting console cable

Take the following steps to connect the console cable, when configuring the switch on the terminal.

Step 1: Plug the DB-9 or DB-25 female connector of the console cable into the serial port of the PC/terminal where the switch is to be configured.

Step 2: Connect the RJ-45 connector of the console cable to the console port of the switch.



The PC serial port is not hot-swappable, so you are not allowed to insert or remove the console cable into or from the PC serial port.

When connecting the console cable, first connect the DB9/DB25 end to the PC serial port and then the RJ45 end to the console port of the switch. And removing the console cable is just in inverse order.

When removing the console cable, first remove the RJ-45 end and then the DB9/DB25 end.

Connecting AUX Cable

You need an AUX cable when configuring the Switch 8800 Family with the remote modem dial-up approach.

Introduction

AUX cable is an 8-core shielded cable. At one end of the cable is an RS-232-compliant RJ-45 connector that can be plugged into the console port of the switch. At the other end are DB-9 (male) connector and DB-25 (male) connector. You can plug either of them into the DB-9 (female) or DB-25 (female) port of the modem as needed. The following figure illustrates the AUX cable.

Figure 49 AUX cable

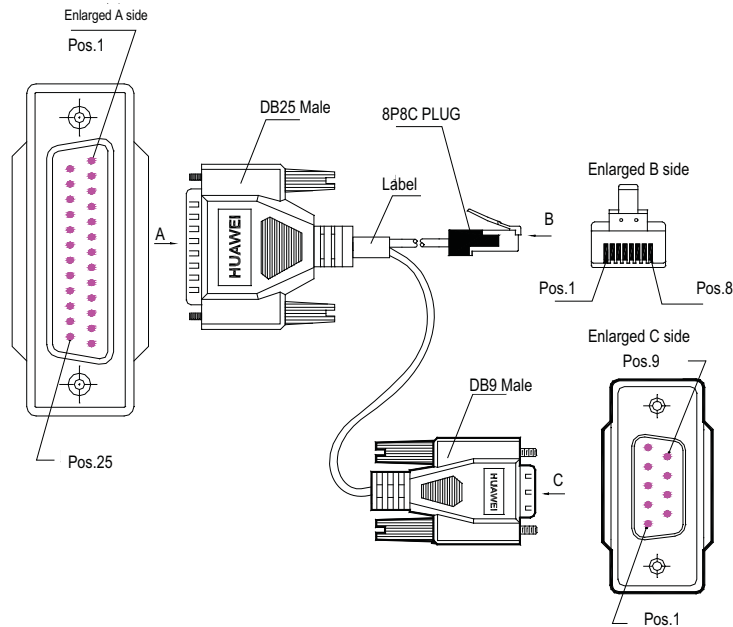

Table 72 AUX cable pinouts

RJ-45	Signal	Direction	DB-25	DB-9
1	RTS	→	4	7
2	DTR	→	20	4
3	TXD	→	2	3
4	CD	←	8	1
5	GND	-	7	5
6	RXD	←	3	2
7	DSR	←	6	6

Table 72 AUX cable pinouts

RJ-45	Signal	Direction	DB-25	DB-9
8	CTS	←	5	8

Connecting AUX cable

Step 1: Plug the RJ-45 connector of the AUX cable into the AUX port of the switch.

Step 2: Plug the DB-25 (male) or DB-9 (male) connector at the other end into the serial port of the analog modem.

Connecting Category-5 Shielded Cable**Introduction to RJ-45 connector**

Being RJ-45 connector, the 10Base-T/100Base-TX port of the Switch 8800 Family supports MDI/MDIX auto-sensing and will be connected using the category-5 shielded cable. The following figure illustrates an RJ-45 connector.

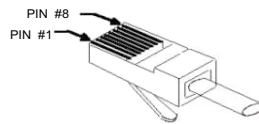
Figure 50 RJ45 connector**Connecting category-5 shielded cable**

Step 1: Plug one end of the network cable into the desired Ethernet RJ-45 connector on the switch.

Step 2: Plug the other end of the cable into the RJ-45 port of the peer device.

Connecting Fiber

All the megabit and gigabit optical modules available for the Switch 8800 Family are SFP modules that provide LC user ports.

Introduction to fiber connector

- When selecting a fiber network facility, make sure that the type of the connector and the fiber match the adopted optical port.
- Before connecting the fiber, make sure that the receive-end optical power does not exceed the upper threshold of the receiving optical power. Excessive receiving optical power is very likely to burn the optical module.

Fiber connectors are indispensable passive components in an optical fiber communication system. Their application allows the removable connection between optical channels, which makes the optical system debugging and maintenance more convenient and the transit dispatching of the system more flexible. Among various fiber connectors, only LC connector will be introduced here.

- LC fiber connector

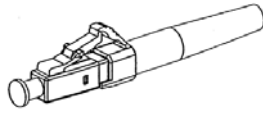
Figure 51 LC connector**Connecting fiber**

Step 1: Plug one end of the fiber into the SFP optical module of the Switch 8800 Family.

Step 2: Connect the other end of the fiber into the corresponding device.



CAUTION: When the optical interface has not been connected with a fiber connector or its dust-proof mesh is open, there might be some invisible radiation emitted from the optical interface. So do not look into the optical interface directly.

Cover the optical interface if there is no connector plugged in.

Cable Routing Recommendations

Freestanding Switch on Tabletop

For only selling an integrated chassis, you do not have to care about the cabling inside or outside the cabinet. All the I/O module cables are routed from the left side of the chassis (along the cabling channel), and the chassis power cords (AC/DC power cords) are routed in the front of the chassis.

Cabinet-Mounting Switch

If the switch is mounted in a 19-inch standard cabinet or B68-22 cabinet, the I/O module cables are bound on the cabling rack at the left side of the chassis and are routed up or down to pass through the chassis top or the raised floor depending on the available equipment room condition (that is, the signal cables are routed into the chassis either from the cabling rack on the chassis top or from the cabling trough under the floor) of the exchange office. The power cords run along the left-front of the chassis and out of the chassis either from the top or the raised floor depending on the equipment room conditions (DC power distribution cabinet, lightning protection box, and terminal block, etc.) of the exchange office.

Cable Management

Cable Management Requirements

- Bundle and put the cables inside the cabinet in a straight and neat way. No intertwinement or bending is allowed.

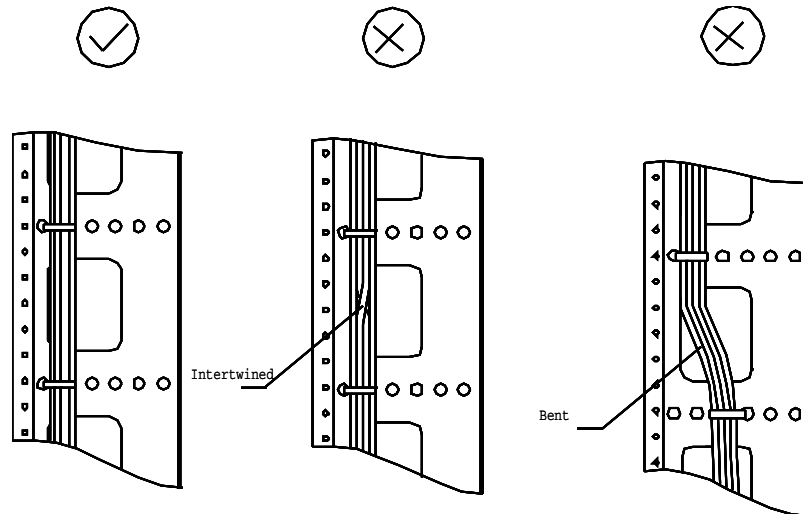
Figure 52 Cable bundling example I

- The bending radius of cable body cannot be less than twice of the cable diameter. The bending radius of the cable cannot be less than 5 times of its diameter at the place where it is led out of the connector;
- Different cables (power cord, signal cable, PGND wire, etc.) should be cabled and bundled separately rather than together in the cabinet. If they are close to each other, you can cable them in cross-shape. For parallel cabling, the space between power cord and signal cable should be no less than 30 mm (1.2 in);
- The cable binding rack and cabling channel inside and outside the cabinet should be smooth and without sharp edges or tips;
- The metal cable management hole should have a smooth and fully rounded surface or wear a insulating bush;
- Use the right type of ties to bundle the cables. Do not bundle cables with joined ties. 3Com Corporation provides the following types of ties: 100 x 2.5 mm (3.9 in x 0.1 in), 150 x 3.6 mm (5.9 x 0.1 in), 300 x 3.6 mm (11.8 x 0.1 in), 530 x 9 mm (20.9 x 0.4 in), and 580 x 13 mm (22.8 x 0.5 in);
- Cut the extra parts of the ties neatly after bundling the cables, leaving no sharp or angular tips. See the following figure:

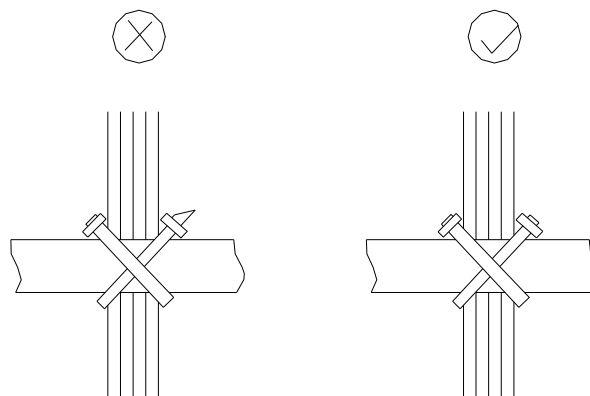
Figure 53 Cable bundling example II

- Bundle the cables wherever cable bending cannot be avoided. However, the cable ties cannot be placed inside the bending area in case of the likelihood of cable core break due to excessive stress. See the following figure.

Figure 54 Cable bundling example III

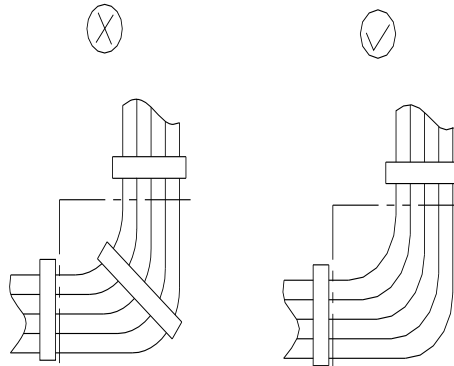

- The spare cables or excessive cable parts should be folded and bundled and placed at a right place in the cabinet or on the cabling channel. A “right place” refers to the place where the cables will not affect the operation of the device or impair the device, or be damaged;
- The power cords cannot be tied on the guides of any mobile components;
- Reserve some redundancy for the cables connecting to the mobile parts, the PGND wire of the door for example, to free the cables from possible stress. Such a mobile part should be installed in such a way that the extra cable segments will be kept from contacting the heat source, sharp points or edges. Use high temperature cables near the heat sources;
- For the cable terminals fixed using screw threads, the screws or nuts should be securely fastened and prevented from losing. See the following figure;

Figure 55 Cable fixing example

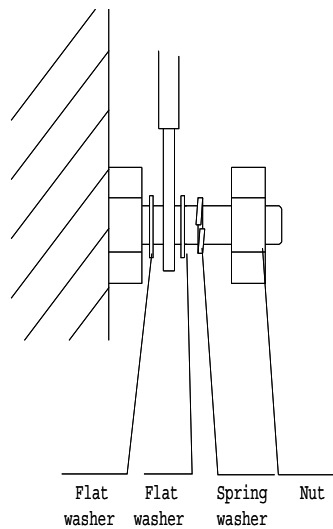

- When using a hard power cord, fix it near its terminal so as to free the terminal and the cable from stress;
- Do not use tapping screws to fasten the connecting terminals;
- The power cords of the same type and in the same direction should be bundled together and kept neatly and straight;

The following table lists the requirements in the bundling with cable ties.

Table 73 Tie-binding parameters

Cable bundle diameter (mm)	Space between bundles (mm)
10	80 to 150
10 to 30	150 to 200
30	200 to 300

- No cable or bundle can tie a knot;
- The metal parts of the crimped cold-pressed terminal blocks (such as air switch) cannot stretch beyond the blocks.

Verifying the Installation



CAUTION: Confirm that you have turned off the power before checking, otherwise, improper connection will hurt people or impair the components of the switch.

After installing the switch, verify the installation by the following list, ensuring all the checking results are normal.

Table 74 Installation checking list

Item	Normal	Abnormal (Description)
ESD-preventive wrist strap		
Console cable		
PGND wire		
Power cord		
fabric		
I/O module/Application Module		
Fan tray		
PSU		

5

DEBUGGING THE SYSTEM

Setting up Configuration Environment

Connect a terminal (a PC in Figure 56) to the switch with a console cable.

Figure 56 Networking environment for switch configuration

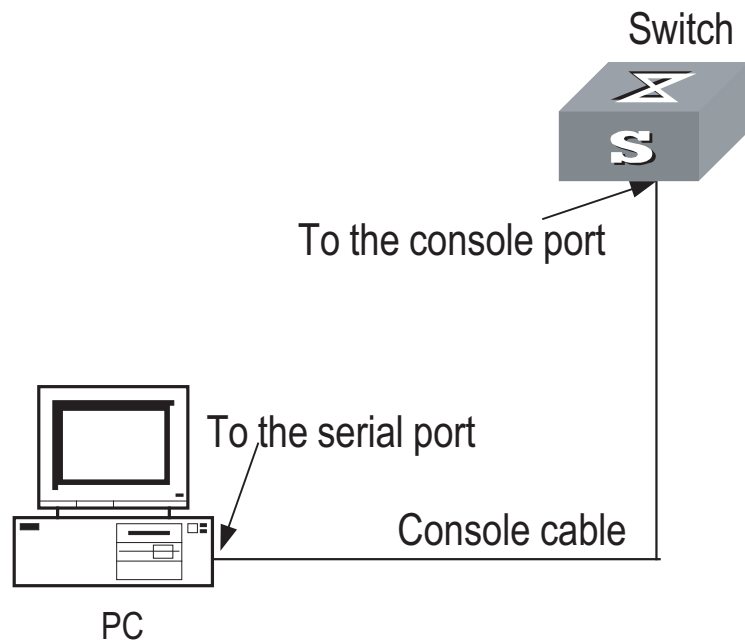

Connecting the Cables

- 1 Insert the DB-9 (or DB-25) female connector of the Console cable into the serial port on the PC (the Console terminal).
- 2 Insert the RJ-45 connector of the cable into the Console port on the switch.

Setting the Terminal Parameters

Set baud rate to 9600, data bits to 8, parity check to none, stop bits to 1, flow control to none, and terminal emulation to VT100.

This section will tell you how to set the terminal parameters, taking a PC running Windows 98 Hyper Terminal as an example.

Step 1: Start PC, and run terminal emulation program (such as Terminal of Windows3.1, or Hyper Terminal of Windows 95/Windows 98/Windows 2000/Windows NT/Windows XP/Windows ME) on PC.

Step 2: Set parameters in the Hyper Terminal of Windows98.

You must set the baud rate to 9600, data bits to 8, no parity check, stop bit to 1, and flow control to none, and select VT100 for terminal emulation. Specifically,

- 1 Click **Start**→**Programs**→**Accessories**→**Communications**→**HyperTerminal** to access the Hyper Terminal window. The Connection Description dialog box displays.
- 2 Click the red phone icon in the window to set up a new connection.
- 3 Enter the name of the new connection in the Name field and **OK**. The Properties dialog box displays.
- 4 Select the target serial port to be used in Connect using field, and click **OK**. The Port Settings Properties dialog box display.
- 5 Set the connecting serial interface parameters. Set the bits per second to **9600**, data bits to **8**, Parity to **None**, stop bits to **1**, and flow control to **None**, then click **OK**. The HyperTerminal dialog box displays.
- 6 Select **File**→**Properties** to access the 3Com Properties Window.
- 7 Click the **Settings** tab, select **VT100** for terminal emulation, and click **OK** to confirm the settings.



It is recommended that you set the function, arrow, and Ctrl keys to act as Windows keys.

Powering and Booting the Switch

Verifying Installation before Powering the Switch

You should verify the installation of the switch before powering it on, to make sure that:

- The switch is stable enough.
- All the boards have been correctly installed.
- All the communication cables, fibers, power cords, and grounding wires are correctly connected.
- The proper power voltage is used as required by the switch.
- The Console cable has been correctly connected, the PC or terminal for configuration has been in service and all the required terminal parameters have been set.



CAUTION: *Before powering on the switch, locate the position of the power switch for the equipment room where you will operate so that you can switch off the power supply promptly if needed.*

Powering on the Switch

- Turn on the power switch of the power source providing power to the switch.
- Turn on the power switch.

Verifying after Power-on (Recommended)

To ensure the configuration works that you will make on the switch, you are recommended to check the switch after powering it on to make sure that:

- The cooling system is working. In this case, you can hear the noise caused by fan rotation and feel that there is air exhausted out.

- All the system LEDs on the fabrics function normal.

Boot Interface The Switch 8807 is used as an example in this section.

The following is the information that will be output at the Console terminal when you power on the switch.

```
ZBB_TEST
Starting...
*****
*
* 3Com Switch 8800 Family Bootrom, Version 106 *
*
*****
Copyright (C) 2001-2005 by 3Com CORPORATION
Creation date: Jun 6 2003, 19:28:01
CPU type      : MPC755
CPU L2 Cache  : 1024KB
CPU Clock Speed : 400MHz
BUS Clock Speed : 100MHz
Memory Size   : 512MB

Flash file system init....done

Switch 8800 Family 3C17508 board self testing.....
The board is steady
SlotNo of this 3C17508 is 0
BootRom main system CRC check is OK
82559 register testing is OK
EPLD1 testing is OK
EPLD2 testing is OK
16c2552 register testing is OK
Please check LEDs.....LED testing finished
The switch Mac address is 00e0.fc00.00a1
Press Ctrl+B to enter Boot Menu... 0
Auto-booting...
Booting from Flash...
Decompress Image.....
.....OK!
Starting at 0x10000...
User interface Con 0 is available
Press ENTER to get started.
```

The above prompt information appears when the switch completes its boot sequence. Press **Enter** to begin configuring the switch.



The Switch 8800 Family provide abundant command views. For more information about the configuration commands and the Command Line Interface (CLI), see 3Com Switch 8800 Family Routing Switches Operation Manual.

6

SWITCH MONITORING AND MAINTENANCE

Monitoring the Switch

Although the Switch 8800 Family has undergone a comprehensive factory test before delivery, an improper installation may cause problems. This chapter describes how to troubleshoot the Switch 8800 Family.

Troubleshooting Console Terminal

If the system running properly, when you power on the switch, you will see the boot information on the console terminal. If the switch is configured incorrectly, the console terminal may display illegible output or nothing at all.

If the console does not display anything after you power on the switch, check that the:

- Power system is working normally.
- Fabric is working normally.
- Console cable is connected to the console port on the fabric.

If you find no issues with these items, the problem is most likely one of the following:

- The console cable is not connected to the right serial port. That is, the port in use is not the one configured on the terminal.
- There are console terminal parameter errors. (According to the parameter setting requirements, you should set the baud rate to 9600, data bits to 8, parity to None, stop bits to 1, flow control to None, and select VT100 as your terminal emulation protocol.)
- The console cable is not in good condition.

If the terminal displays illegible characters, it is most likely a console terminal setting error. Check that you have set the baud rate to 9600, data bits to 8, parity to None, stop bits to 1, flow control to None, and select VT100 as your terminal emulation protocol.

Troubleshooting the PSU

Table 75 LEDs on the PSU

LED	Description
INPUT	It stays ON if the power input is normal and the PSU switch is at the ON position. It stays OFF if the power input has failed or if there is no power input at all.
OUTPUT	It stays ON if the power output is normal, otherwise it is OFF.
FAIL	It stays ON if the PSU has failed, otherwise it is OFF.

The following PSU faults may appear on the switch. Follow the instructions provided to resolve the problem.

Display Power Command Indicates the PSU is Not in Position

The Input LED (green) and Output LED (green) stay ON, but the **display power** command shows that the PSU is not in position (but the other PSU operates normally). This problem is likely caused by a poor connection (badly seated) between the PSU and the backplane. To correct this:

- 1 Switch off the power supply
- 2 Loosen the screws on the PSU
- 3 Push the PSU into the chassis a little bit
- 4 Tighten the screws
- 5 Switch on the power supply to check that the normal state is resumed

The Input LED (green) and Output LED (green) are OFF

Check that the power cords are connected correctly, the power cords are in good condition, and the power switch has been put in the ON position.

The Fail LED (red) is ON

Check that the:

- Correct power voltage is in use (90 to 264VAC, 50-60 Hz for AC PSU).
- Air filter protecting the fan tray is clean. Excessive dust accumulated on the air filter may block the fan tray from free ventilation and can lead to power supply failure.



If the problem persists, contact 3Com technical support engineers. Do not disassemble the PSU yourself.

Troubleshooting Fan Tray

The Switch 8800 Family provides two LEDs on the fan tray as described in Table 76.

Table 76 Fan tray LEDs

Indicator	State description
RUN	Green indicates that the fan tray is operating normally.
	OFF indicates that the fan tray has failed.
ALM	Red indicates that the fan tray has failed.
	OFF indicates that the fan tray is in operating normally.



The ALM LED on the fan tray stays ON for two to three seconds when the switch is powered on.

If the RUN LED is OFF, check that:

- The fan tray has been well seated.
- All the cables connecting the fan tray to the backplane are connected and are in good condition.

- The fans are working normally.
- The rotation of the fans has not been blocked.
- The blank filler panels have been inserted into the I/O module slots.

Troubleshooting I/O Module

The Switch 8800 Family provides I/O module LEDs on the fabric so that you can check the state of these I/O modules.

Table 77 I/O Module LEDs

Indicator	State description
RUN	ON indicates an I/O module failure. OFF indicates that the I/O module has failed or it is not in position at all. Blinking indicates that the I/O module is working normally.
ALM	OFF indicates that there is no I/O module alarm or that the I/O module is not in position at all. ON indicates that there is an I/O module alarm.
2~6 (Switch 8807)	On the Switch 8807, I/O module 0 through I/O module 4 respectively correspond to slots 2 through 6.
0~3, 6~9 (Switch 8810)	On Switch 8810, I/O module 0 through I/O module 7 respectively correspond to slots 0 through 3 and 6 through 9.
0~5, 8~13 (Switch 8814)	On Switch 8814, I/O module 0 through I/O module 11 respectively correspond to Slots 0 through 5 and 8 through 13.

Hardware Maintenance

Replacing AC PSU



CAUTION: The Switch 8800 Family's PSU is hot-swappable. Refer to the document entitled "3Com Switch Family Safety and Regulatory Information," part number 10015300, for information about how to install and set up your switch safely. Also:

- The Switch 8800 Family uses multiple power systems, and you must turn off all of them when removing the AC PSU.
- The PSU of the Switch 8800 Family is heavy. Use both hands to pull it out slowly and gently, with one holding its handle and the other holding its bottom.
- If you are not installing a replacement PSU, insert a blank filler panel into the PSU slot so that dust cannot get into the unit and to allow proper ventilation.

Removing an AC PSU

To remove an AC PSU:

- 1 Change the power switch on the PSU from the ON position into the OFF position.
- 2 Pull right the clamp holding the power cord connector and unplug the power cord.
- 3 Unscrew the screws on the both sides of the PSU panel with a flathead screwdriver.

- 4 Hold the handle of the PSU and pull the PSU gently out of the chassis along the guides.

Figure 57 Remove and install the AC PSU

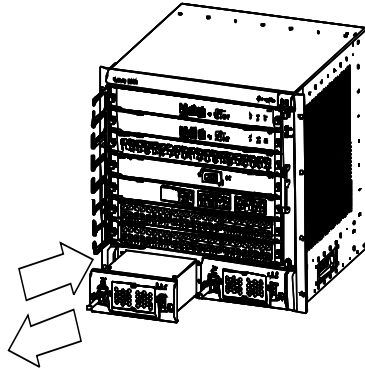

Installing an AC PSU

- 1 Hold the handle of the PSU with one hand and the bottom of the PSU with another hand, and gently slide the PSU into the chassis along the guides until it is secure in the backplane.
- 2 Fasten the screws at both sides of the PSU panel with a flathead screwdriver.
- 3 Check that the power switch on the panel is in the “OFF” position and the clamp holding the power cord connector is pulled up.
- 4 Insert the AC power cord included with the switch into the socket on the PSU.
- 5 Pull the clamp down to hold the power cord.

Replacing and Cleaning the PCU’s Air Filter

This section describes how to clean and replace the Switch 8800’s AC PSU air filter.



CAUTION: We strongly recommend that you clean the air filter semimonthly to guarantee adequate ventilation.

Removing and cleaning the air filter of PSU

- 1 Hold the air filter by the upper and lower edges with your index finger and thumb.
- 2 Gently pull the air filter out of the chassis.
- 3 Take the black air filter mesh out.
- 4 Clean and dry (but do not rub) the mesh.
- 5 Place the dry black mesh back into position.

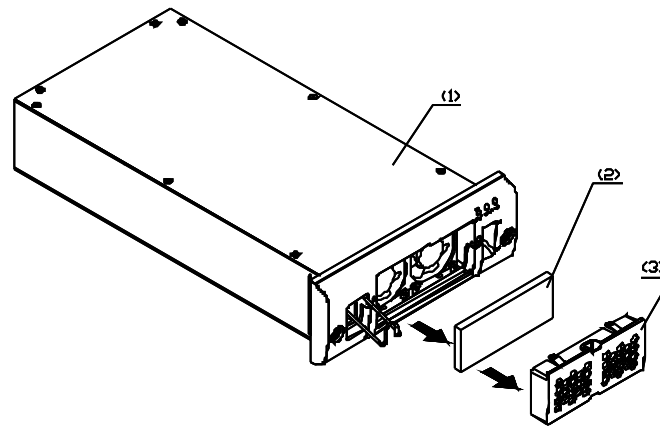
Figure 58 Remove the air filter of AC PSU

(1) PSU

(2) Air filter

(3) Air filter cover

Installing the air filter of PSU

To install the PSU's air filter:

- 1 Ensure that the black mesh is contained within the air filter cover.

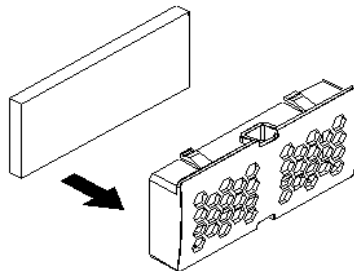
Figure 59 Installing the PSU Air Filter

- 2 Hold the air filter cover by the upper and lower edges with your index finger and thumb and push it inside the PSU.

Replacing and Cleaning the Chassis's Air Filter

CAUTION: We recommended that you clean the air filter semimonthly to guarantee adequate ventilation.

You install the Switch 8800's air filter at the chassis's air intake vents. If you do not clean the air filter often, the accumulated dust blocks the filter's holes and affects the chassis's ventilation. Use one of the following two methods to clean the filter, but do not rub the air filter when you wash it. Allow it to air dry.

Removing and Cleaning the Chassis's Air Filter

- 1 Unscrew the screws at the top and bottom of the air filter with a flathead screwdriver.
- 2 Hold the air filter at the left-rear by its upper and lower edges, pull part of it out of the chassis, put one hand underneath the air filter to hold it, and pull it out slowly along the guides.



CAUTION: Because the air filter is rather long, you should hold its front end with one hand, and bear its weight by putting another hand underneath it when sliding the air filter out of the chassis.

- 3 Rather than taking the air filter mesh out, directly wash the air filter after removing it from the chassis, allow it to air dry, and insert it back into the chassis.

Installing the Chassis's Air Filter

- 1 Hold the front end of the air filter with one hand and put the other hand underneath it, align it with the guides, and slide it into the chassis along the guides.
- 2 Fix the air filter by fastening the screws at the top and bottom of the air filter with a flathead screwdriver.



CAUTION: As the air filter is rather long, you should hold its front end with one hand, and bear its weight by putting another hand underneath it when sliding the air filter into the chassis.

Replacing a Module

The Switch 8800's fabric, I/O modules, and application modules are similar in structure and you can install and remove them in the same way. This section describes the general procedures for removing and installing these modules.

The Switch 8800 Family modules are hot-swappable.

Required tools

- ESD-preventive wrist strap
- Screwdriver

Removing a Module

To remove a module:

- 1 Wear the ESD-preventive wrist strap and unscrew the screws on the module with a flathead screwdriver.
- 2 Hold the ejector levers on the module with both hands and press them outward to separate the module's locking pin from the backplane.
- 3 Gently pull the module out of the slot along the guides.

Figure 60 Removing a Module



Installing a Module

- 1 Wear the ESD-preventive wrist strap and unscrew the mounting screws fixing the blank filter panel in the slot where you want to install the module, and remove the blank filler panel.
- 2 Hold the ejector levers of the card with both hands and pull them outward, align the card with the guides in the chassis, and slide it gently into the slot until its positioning pin touches the positioning hole in the chassis.
- 3 Pull the ejector levers inward to lock the positioning pin of the card into the positioning hole in the chassis.
- 4 Fasten the screws to fix the card.

Figure 61 Installing a Module

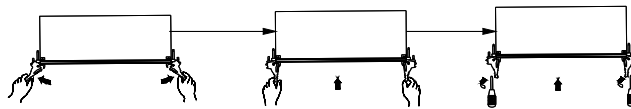

Replacing the Fan Tray



CAUTION: To avoid bodily injury, do not touch exposed wires, terminals, or the switch parts where a dangerous voltage warning label is indicated.

Required tools

- ESD-preventive wrist strap
- Screwdriver

Replacing the Fan Tray

To replace the fan tray:

- 1 Wear the ESD-preventive wrist strap.
- 2 Remove the screws from both sides of the fan tray.
- 3 Pull the fan tray out with one hand on the top and the other hand around the handle of the fan tray to separate the fan tray positioning pin from the backplane.



CAUTION: When you replace the fan tray of an operating switch, pull the fan tray out from the chassis only after the fans stop rotating. In this case, there is still the possibility that fans are still rotating. Therefore do not put your hand into the fan tray to avoid bodily injury.

- 4 Gently pull the fan tray out of the slot along the guides and place fan tray into the packing bag.
- 5 Hold the fan tray's handle with one hand and its bottom with the other and pull them outward.
- 6 Align the fan tray with the guides in the chassis and slide it gently into the slot until its positioning pin touches the positioning hole in the chassis.
- 7 Insert screws on both sides of the fan tray.



CAUTION: Install a new fan tray soon after removing the old one to ensure that the switch operates normally.

Upgrading the Software

This section describes how to updated the software on the Switch 8800.

- Required cables**
- Console cable (for serial interface)
 - One crossover and one standard network cables
 - Debug cable (for serial interface)

To upgrade the software:

- 1 Confirm that the host program is loaded before initiating the software upgrade.
- 2 Check the current version of the host and Boot ROM programs.
- 3 Back up the current host program, Boot ROM program, and configuration file (to you PC) so that you can roll back a failed upgrade.
- 4 Load the host and Boot ROM program files to the switch. If the switch has two fabrics, you can copy the host and Boot ROM program files to the standby fabric.
- 5 Upgrade the Boot ROM program on the fabric and I/O module (optional).
- 6 If the switch has two fabrics, specify the load programs for the active and standby fabrics.
- 7 Reboot the switch.
- 8 Check that the board version is correct.
- 9 Load the software through command line interface (CLI) or the Boot menu. You can load it through CLI using FTP or TFTP. You can load it locally from the Boot menu using:
 - XModem and through Console port
 - TFTP and through Ethernet port
 - FTP and through Ethernet port

Each method is described below.

Upgrading Locally through the Boot Menu

After powering on the switch, run the Boot ROM program. The terminal displays the following information:

```
ZBB_TEST
Starting...
*****
*                                     *
*           3Com Switch 8800 Family Bootrom, Version 109
*
*                                     *
*****
Copyright (C) 2001-2005 by 3Com CORPORATION
Creation date: Dec 9 2003, 16:19:42
CPU type      : MPC755
CPU L2 Cache  : 1024KB
CPU Clock Speed : 400MHz
BUS Clock Speed : 100MHz
Memory Size   : 512MB
Flash file system init...done
Board type: Switch 8800 Family 3C17539
```

```

Board self testing.....
The board is steady
SlotNo of this board is 6
The MCX is exist
BootRom main system CRC check is OK
82559 register testing is OK
EPLD1 testing is OK
EPLD2 testing is OK
16c2552 register testing is OK
Please check LEDs.....LED testing finished
The switch Mac address is 00e0.fc00.1111
Press Ctrl+B to enter Boot Menu... 5
Password :

```

- 1 Press <Ctrl+B> as prompted to display the system Password : prompt.



To enter the Boot menu, you must press <Ctrl+B> within five seconds after the appearance of the "Press Ctrl-B to enter Boot menu..." prompt. Otherwise, the program decompression process begins. To access the Boot menu after the switch enters the program decompression process, you need to restart the switch.

- 2 Enter the Boot ROM password (the switch's default is no password). The Boot menu displays as follows:



CAUTION: Make sure you have Boot ROM password.

```

MAIN MENU
1. Boot with default mode
2. Boot from Flash
3. Boot from HardDisk
4. Enter serial submenu
5. Enter ethernet submenu
6. Modify Flash description area
7. Modify bootrom password
0. Reboot
Enter your choice(0-7):

```

- 3 Ensure that the upgraded host program is compatible with the existing I/O module's Boot ROM program. Otherwise, you must upgrade it during a host program upgrade.
- 4 When loading the host program through the Boot menu, configure the serial interface's attributes as shown in Figure 62. Otherwise, the Hyper Terminal does not respond.

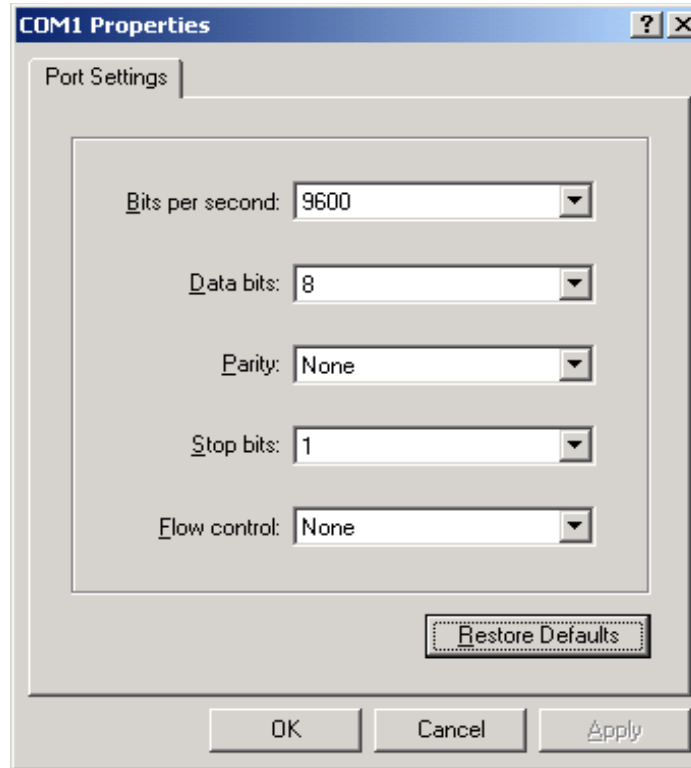
Figure 62 Hyper Terminal serial interface attribute settings

Upgrading software through console port (XModem)

XModem is a file transfer protocol used for its simplicity and performance. It transmits files through serial interfaces, supporting 128 bytes and 1Kbytes in data units, checksum and CRC checking modes, and multiple transmissions attempts (usually 10 attempts) when packet errors are found.

XModem completes the transmission by the receiving program (receiver) and the sending program (sender). In XModem, the transmission begins by sending negotiation characters from the receiver for the purpose of check mode negotiation. After passing the negotiation, the sender is allowed to send the first data packet. Upon receiving the complete packet, the receiver checks the packet using the agreed upon check mode and sends an ACK if the packet has passed the check and a NAK if it did not. After receiving the ACK, the sender sends the next packet; if it receives a NAK, the sender retransmits the previously sent packet.

To run the Xmodem application:

- 1 In the Boot menu, type **4**, press **Enter**, and the system accesses the serial interface submenu as follows:

```
SERIAL  SUBMENU
1. Download file to SDRAM through serial interface and boot
2. Download file to Flash through serial interface
3. Download file to HardDisk through serial interface
4. Modify serial interface boot parameter
0. Return to main menu
Enter your choice(0-4):4
```

- 2** Type **4** in the serial interface submenu and press **Enter** to set the serial interface download parameters from the following menu:

```
1: 9600 (default)
2: 19200
3: 38400
4: 57600
5: 115200
please select an appropriate baudrate:
Enter your choice(1-5): 5
```

- 3** Select the download speed as needed. For example, enter **5** to select the download speed of 115200 bps, then press **Enter**. The system displays the following information:

```
BaudRate is 115200 bps. Please change the terminal's speed to 115200
bps
```

- 4** Change the baud rate on the Console terminal to match your specification, disconnect the terminal, connect it again, then press **Enter**. The terminal displays the serial interface submenu again:

```
SERIAL SUBMENU
1. Download file to SDRAM through serial interface and boot
2. Download file to Flash through serial interface
3. Download file to HardDisk through serial interface
4. Modify serial interface boot parameter
0. Return to main menu
Enter your choice(0-4):2
```



- *After changing the baud rate, you must close the terminal emulation program and start it again at least once in order to validate the new baud rate.*
- *In Windows 98, you can disconnect and reconnect the terminal after changing the baud rate. In Windows 2000, you must disconnect the terminal before setting the baud rate and reconnect the terminal after it is complete.*

- 5** Choose where you wish to store the downloaded file. For example, enter **2** to download the file into the switch's Flash memory then, press **Enter**. The system displays the following information as it is downloading the file:

```
Please Select File .
XMODEM downloading ...CCC
```

- 6** Select **[Transfer/Send File]** in the terminal window. The Send File dialog box appears as shown in Figure 62.
- 7** Click **Browse**, and select the application, and change the protocol to XModem.

Figure 63 Send File dialog box

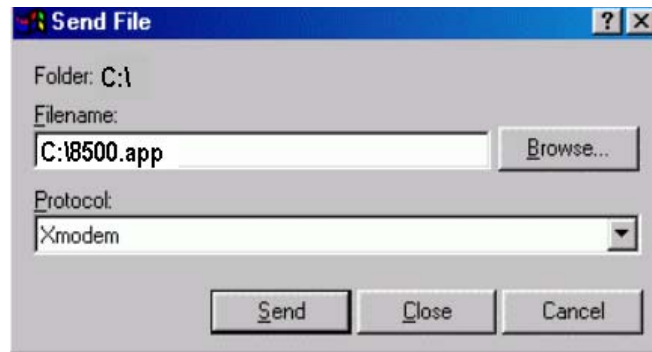

- 8 Click **Send**. The Xmodem dialog box displays.
- 9 After downloading the program successfully, the system begins to write the data into the Flash memory. When the download is finished, the serial interface displays the following submenu again.

```

XMODEM downloading ...CCC download successfully!
flash:/ s8500.app already exist,
delete it?(Y/N):y
Deleting file-----
-----Done

Free flash Space : 15862784 bytes
Writing flash-----
-----Done

SERIAL SUBMENU
1. Download file to SDRAM through serial interface and boot
2. Download file to Flash through serial interface
3. Download file to HardDisk through serial interface
4. Modify serial interface boot parameter
0. Return to main menu
Enter your choice(0-4):
    
```

Upgrading the Software Using TFTP

Trivial File Transfer Protocol (TFTP) transmissions are initiated by the client. When downloading a file, the client sends a read request packet to the TFTP server, receives the data packets from the server, and sends the ACK to the server. When uploading a file, the client sends a write request packet to the TFTP server, then sends the data packets to the server, and receives the ACK from the server. The TFTP transmission files have two forms; binary for program transmission and ASCII for text transmission.

To upgrade the software using TFTP perform the following steps.



This procedure uses a Switch 8814 work as the TFTP client.

- 1 Connect the switch to a PC where the file is located using the management/upgrade Ethernet port. (You need the IP address of the PC. At the same time, connect the switch to an external PC (that can be the same one that contains the file) using the console port.
- 2 Run the TFTP server program on the PC connected to the management/upgrade Ethernet port and specify the path for upgrading the application files.
- 3 Run the terminal emulation program on the PC connected to the console port, and boot the switch to access the Boot menu.

- 4 Enter **5** at Boot menu prompt and press **Enter**. The system displays the download application program menu:

```
ETHERNET  SUBMENU
1. Download file to SDRAM through ethernet interface and boot
2. Download file to Flash through ethernet interface
3. Download file to HardDisk through ethernet interface
4. Modify ethernet interface boot parameter
0. Return to main menu
Be sure to select 4 to modify boot parameter before downloading!
Enter your choice(0-4): 4
```

- 5 Enter **4** to select TFTP for upgrading the software and press **Enter** to set the related TFTP parameters:

Note: Two protocols for download, tftp & ftp.
 You can modify the flags following the menu.
 tftp--0x80, ftp--0x0.



The message prompts you to set the flags to 0x80 when you download files using TFTP and to 0x0 if you are using FTP.

```
'.' = clear field; '-' = go to previous field; ^D = quit
boot device      : fei0
processor number :
host name        : 8500 ,
file name        : 8500.app
inet on ethernet (e) : 1.1.1.1
inet on backplane (b):
host inet (h)    : 1.1.1.2
gateway inet (g) :
user (u)         :
ftp password (pw) (blank = use rsh):
flags (f)        : 0x80
target name (tn) :
startup script (s) :
other (o)        :
Write flash...done!
```

- 6 After you provide the required information, the system accesses the Ethernet interface submenu appears again:

```
ETHERNET  SUBMENU
1. Download file to SDRAM through ethernet interface and boot
2. Download file to Flash through ethernet interface
3. Download file to HardDisk through ethernet interface
4. Modify ethernet interface boot parameter
0. Return to main menu
Enter your choice(0-4): 2
```

- 7 Specify where you wish to download the file (**2** if you wish to download the file to Flash), press **Enter**. Upon successful completion, the system displays the following information:

```
Attached TCP/IP interface to fei0.
Attaching network interface lo0... done.
boot device      : fei0
unit number      : 0
processor number : 0
host name        : 8500
file name        : 8500.app
```

```

inet on ethernet (e) : 1.1.1.1
host inet (h)       : 1.1.1.2
flags (f)          : 0x80
Prepare for loading...OK
Loading.....done
flash:/s8500.app already exist,
delete it?(Y/N):y
Deleting file-----
-----Done
Free flash Space : 15862784 bytes
Writing Flash-----
-----Done

```

- 8 The system accesses the Ethernet interface submenu again as shown below.

```

ETHERNET  SUBMENU
1. Download file to SDRAM through ethernet interface and boot
2. Download file to Flash through ethernet interface
3. Download file to HardDisk through ethernet interface
4. Modify ethernet interface boot parameter
0. Return to main menu
Enter your choice(0-4):

```

Upgrading software Using (FTP)

The Switch 8800 Family applications can also be updated through the Ethernet port using FTP.



This procedure uses a Switch 8814 work as the FTP client.

- 1 Connect the switch to the PC containing the file using the management/upgrade Ethernet port. (You need the IP address of the PC.) Connect the switch to an external PC (that can be the same one that contains the file) through the console port.
- 2 Run the FTP server on the PC connected to the management/upgrade Ethernet port. Specify the path to the upgrade file and set the login username and password.
- 3 Run the terminal emulation program on the PC connected to the Console port, and boot the Switch to access the Boot menu.
- 4 See the corresponding steps (4 through 8) in the upgrading procedure using TFTP above.



If you want to download files using FTP, please set the flags to 0x0 when setting the Ethernet interface parameters.

- 5 After downloading the host program through the Boot menu, you must specify it as the next boot program. In the following example, the host program is Switch 8800 Family-Comware 310-R1212.app.

```

MAIN  MENU
1. Boot with default mode
2. Boot from Flash
3. Boot from CF card
4. Enter serial submenu
5. Enter ethernet submenu
6. Modify Flash description area
7. Modify bootrom password

```

```

0. Reboot
Enter your choice(0-7):
Enter your choice(0-7): 6
Please input '0' or '1' ('0':Boot from Flash, '1':Boot from CF card)
BootDev = 0
FlashFileName = Switch 8800 Family-Comware 310-R1212.app

```

Upgrading the Software Using the CLI

If your terminal is connected to the switch over a network, you can load the Boot ROM and host programs remotely through the CLI using FTP or TFTP.

Using FTP

- 1 Run the FTP server on a local PC, provided you have configured username and password and have set the correct file directory. Specify the PC's IP address (for example, 10.10.110.1 in the example below).
- 2 Log on to the switch using Telnet or through the Console port to send host program to the switch using FTP.
- 3 Using the **Get** command, download the main boot file (SWITCH002.app in the example below), the active host program (SWITCH001.app in the example below), and the Boot ROM program (SWITCHbtm.btm in the example below).

```

<3Com> 10.19.110.1
Trying ...
Press CTRL+K to abort
Connected.
220 WFTPD 2.0 service (by Texas Imperial Software) ready for new user
User(none):8500
331 Give me your password, please
Password:
230 Logged in successfully
[ftp] get SWITCH002.app SWITCH002.app
[ftp] get Switchbtm.btm Switchbtm.btm
[ftp] bye

```



If the switch has two fabrics, you also can copy the host and Boot ROM program files to the standby Fabric.

- 4 Specify the next boot program. If the switch has two fabrics, specify the load programs respectively for the active and standby fabrics (the current standby fabric is in slot 7 in the example below).

a Load Boot ROM program

```

<3Com> boot bootrom flash:/Switchbtm.btm slot 6
<3Com> boot bootrom slot7#flash:/Switchbtm.btm slot 7

```

b Load host program

```

<3Com> boot boot-loader flash:/SWITCH002.app
<3Com>boot boot-loader slot7#flash:/SWITCH002.app

```



The URL form of the files in the standby fabric file system must start with "slot[No.]#flash:/", where [No.] is the standby fabric number.

```

<3Com> display boot-loader
The app to boot of board 6 at the next time is: flash:/SWITCH002.app
The app to boot of board 6 at this time is: flash:/SWITCH002.app
The app to boot of board 7 at the next time is: flash:/SWITCH002.app
The app to boot of board 7 at this time is: flash:/SWITCH002.app
<3Com> reboot

```

**CAUTION:**

- You must reboot the switch using the **reboot** command to validate the host program. If Flash memory space is not enough, you can delete some of the program files in Flash after completing the Boot ROM loading. (3Com recommends that you delete the host program that is no longer in use.) Then upload the host program to the switch using FTP.
- Make sure that you have saved other the configuration before rebooting.
- Do not power the switch off during the loading process.

The Boot ROM and host program loading process is now complete.

Using TFTP

Using the CLI to upgrade using TFTP is similar to using FTP. The only difference is that you use the **tftp get** command to download software to the switch. In this case, the switch can only be used as a TFTP client to download the software to its Flash memory from the TFTP server. Once the download is complete all remaining steps are the same.

Upgrading the Application Module Program

If you have the 360G Fabric (3C17508), download the application software image files to the compact flash (CF) and then boot from the CF.

If you have the 720G Fabric (3C17539), download the application software image files directly to the Fabric's onboard flash.

Troubleshooting the Software Upgrade

This section describes the problems may occur during the software upgrade.

No response from the fabric serial interface

Make sure the serial interface cable is in good condition and that its attributes are set correctly.

Uploading the configuration file or host program using FTP fails

Check that the:

- Configuration is correct and that the FTP server is started.
- Flash has enough space for the target files.
- TFTP flag is selected (TFTP is not supported).

The configuration did not save during the I/O module reboot

Before saving the configuration, you must check the operating status of the I/O module. Do not save the configuration during the I/O module reboot. Otherwise, the configuration you want to save may be lost.

I/O module program loading fails or you cannot register for a long period

- Check that the I/O module type is supported on the current host program.
- Check that the I/O module Boot ROM program matches the host program.
- Check that the I/O modules are well seated.
- Insert an I/O module to other slots to make sure it is not defective.

- Check that the host program exists and that the current host program is running.

Insufficient Flash memory

- Empty the recycle bin when the I/O module starts.
- Delete the unused files in the Flash.

Password Loss

If the switch's Super password or Boot ROM password, contact your local support representative.

A

LIGHTNING PROTECTION OF THE SWITCH

Installing a Lightning Arrester for the AC Power

This appendix describes how to install the lightning arrester for the AC power (a socket strip with lightning protection)



CAUTION: A lightning arrester is not shipped with the switch. You must purchase it separately, if needed.

Make sure, when connecting an outdoor AC power cord directly to the switch, that you connect a lightning arrester to the AC power (a socket strip with lightning protection) before you plug the AC power cord into the switch. This helps to prevent damage in the event of a lightning strike. Install your lightning arrester according to its manufacturer's instructions.

Figure 64 A Lightning Arrester

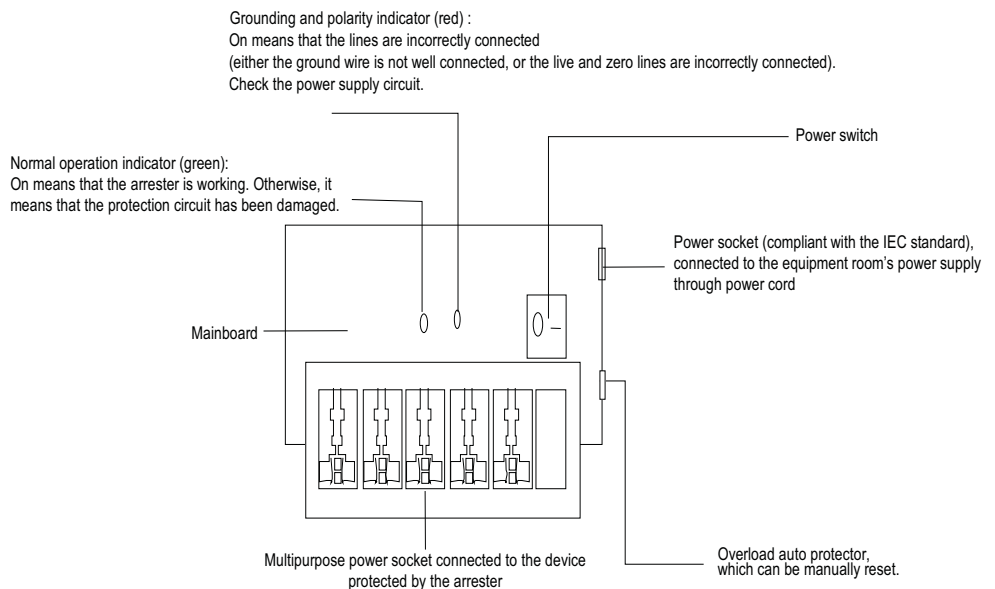

CAUTION:

- Make sure that the arrester is well grounded before using the lightning arrester for power.
- After inserting the switch's AC power cord plug into the lightning arrester's socket, if the green LED is on and the red LED does not alarm, it means that the lightning arrester's power is running and the lightning protection function is active.
- Make sure that the red LED is on. If there is a problem, determine if the arrester's ground wire is well grounded and the live and zero wires are

connected in right direction. When the red LED is on, use a multimeter to examine the polarity at the arrester's power socket. If it is same as that of the power socket in the equipment room, it means that the arrester is not well grounded. If it is adverse to that of the power socket in the equipment room, it means that the arrester's power socket is set to the reverse polarity. In this case, you should open the arrester's power socket and correct the polarity. After that, if the red LED still alarms, it means that the arrester is still not well grounded.

Installing a Lightning Arrester for the Network Port



A network port lightning arrester is specifically designed for an 10/100M electrical interface (an RJ-45 connector in this case) Ethernet port.

Make sure, when connecting an outdoor AC power cord directly to the switch, that you connect a lightning arrester to the AC power (a socket strip with lightning protection) before you plug the AC power cord into the switch. This helps to prevent damage in the event of a lightning strike. Install your lightning arrester according to its manufacturer's instructions.

Required tools

- Phillips screwdriver or flat-module screwdriver
- Multimeter
- Tilted wire cutter

Installation procedure

- 1 Remove the protection paper from one side of the double-faced adhesive tape, and stick the tape to the surface of the arrester. Remove the protection paper from the other side, and stick the arrester onto the switch's chassis as close to the grounding screw as possible.
- 2 Cut the arrester's ground wire to the length of the distance between the arrester and the switch's grounding screw so that you can securely tighten the ground wire to the switch's grounding screw.
- 3 Use the multimeter determine if the arrester's ground wire connects properly chassis's grounding screw.
- 4 According to the instructions provided with your network port arrester, connect the arrester to switch using the cables (Make sure to insert the outdoor network cable into the arrester's IN end, and the cable that is connected to the switch into the arrester's OUT end). Check that the arrester's indicators display correctly.
- 5 Use the nylon ties to bundle the cables neatly.

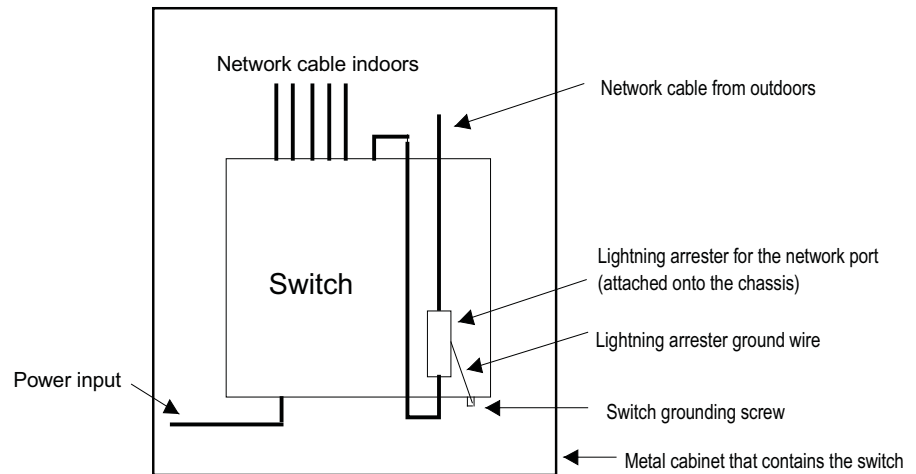
Figure 65 Installation diagram of a network port's lightning arrester**Installation precautions**

To ensure that the network port's lightning arrester does not affect performance, make sure that the lightning arrester for network port is:

- Connected properly (see Step 4 in the previous section).
- Well grounded. The ground wire for the arrester should be as short as possible. Ensure that it has proper contact with the switch's grounding screw using the multimeter.
- Installed completely. If the switch has more than one network ports to interconnect with other devices using outdoor cables, you should install lightning arresters for all network ports for protection.

B

3COM NETWORK MANAGEMENT

3Com has a range of network management applications to address networks of all sizes and complexity, from small and medium businesses through large enterprises. The applications include:

- [3Com Network Supervisor](#)
- [3Com Network Director](#)
- [3Com Network Access Manager](#)
- [3Com Enterprise Management Suite](#)
- [Integration Kit with HP OpenView Network Node Manager](#)

Details of these and other 3Com Network Management Solutions can be found at www.3com.com/network_management

3Com Network Supervisor

3Com® Network Supervisor (3NS) is an easy-to-use management application that graphically discovers, maps, and monitors the network and links. It maps devices and connections so you can easily:

- Monitor stress levels
- Set thresholds and alerts
- View network events
- Generate reports in user-defined formats
- Launch embedded device configuration tools

3NS is configured with intelligent defaults and the ability to detect network misconfigurations. It can also offer optimization suggestions, making this application ideal for network managers with all levels of experience.

To find out more about 3Com Network Supervisor and to download a trial version, go to: www.3com.com/3ns

3Com Network Director

3Com Network Director (3ND) is a standalone application that allows you to carry out key management and administrative tasks on mid-sized networks. By using 3ND you can discover, map, and monitor all your 3Com devices on the network. It simplifies tasks such as backup and restore for 3Com device configurations as well as firmware and agent upgrades. 3ND makes it easy to roll out network-wide configuration changes with its intelligent VLAN configuration tools and the powerful template based configuration tools. Detailed statistical monitoring and historical reporting give you visibility into how your network is performing.

To find out more about how 3Com Network Director can help you manage your 3Com network and to download a trial version, go to: www.3com.com/3nd

3Com Network Access Manager

3Com Network Access Manager is installed seamlessly into Microsoft Active Directory and Internet Authentication Service (IAS). It simplifies the task of securing the network perimeter by allowing the administrator to easily control network access directly from the "Users and Computers" console in Microsoft Active Directory. With a single click, a user (or even an entire department) can be moved to a different VLAN, or a computer can be blocked from connecting to the network.

3Com Network Access Manager leverages the advanced desktop security capabilities of 3Com switches and wireless access points (using IEEE 802.1X or RADA desktop authentication) to control both user and computer access to the network.

To find out more about 3Com Network Access Manager, go to: www.3com.com/NAM

3Com Enterprise Management Suite

3Com Enterprise Management Suite (EMS) delivers comprehensive management that is flexible and scalable enough to meet the needs of the largest enterprises and advanced networks.

This solution provides particularly powerful configuration and change control functionalities, including the capability to:

- Customize scheduled bulk operations
- Create a detailed audit trail of all network changes
- Support multiple distributed IT users with varying access levels and individualized network resource control

The client-server offering operates on Windows and UNIX (Linux and Solaris) systems.

3Com EMS is available in four packages, varying in the maximum number of devices actively managed. These include SNMP-capable devices such as switches, routers, security switches, the 3Com VCX™ IP Telephony server, and wireless access points:

- Up to 250 devices
- Up to 1,000 devices
- Up to 5,000 devices
- An unlimited number of devices

To find out more about 3Com Enterprise Management Suite, go to: www.3com.com/ems

Integration Kit with HP OpenView Network Node Manager

3Com Integration Kit for HP OpenView Network Node Manager offers businesses the option of managing their 3Com network directly from HP OpenView Network Node Manager. The kit includes Object IDs, icons, MIBs, and traps for 3Com devices. The package supports both Windows platforms and UNIX or Solaris platforms. It can be installed as a standalone plug-in to HP OpenView, or used with a 3Com management application such as 3Com Enterprise Management Suite (EMS).

To find out more about 3Com Integration Kit for HP OpenView Network Node Manager, go to: www.3com.com/hpovintkit

Free Manuals Download Website

<http://myh66.com>

<http://usermanuals.us>

<http://www.somanuals.com>

<http://www.4manuals.cc>

<http://www.manual-lib.com>

<http://www.404manual.com>

<http://www.luxmanual.com>

<http://aubethermostatmanual.com>

Golf course search by state

<http://golfingnear.com>

Email search by domain

<http://emailbydomain.com>

Auto manuals search

<http://auto.somanuals.com>

TV manuals search

<http://tv.somanuals.com>