

acer



Leap Ware

USER'S MANUAL

© 2017 All Rights Reserved

Acer Leap Ware User's Manual

Model: L05

This revision: August 2017

Scan to open the
Acer Leap Ware website



go.acer.com/leapware

Download the regulatory
and safety guide (PDF)



go.acer.com/Wearable-Safety-Info



Acer Liquid Life



Important

The Leap Wear is not a medical device. Readings taken by the Leap Ware are to promote a healthy lifestyle, and should not be used or relied on as a medical device to diagnose any medical condition or symptom. Consult a physician before beginning any fitness program.

For more information, please visit: <http://go.acer.com/leapware>.



Important

This manual contains proprietary information that is protected by copyright laws. The information contained in this manual is subject to change without notice. Images provided herein are for reference only and may contain information or features that do not apply to your device. Acer Group shall not be liable for technical or editorial errors or omissions contained in this manual.

Acer Leap Ware

Model number: _____

Serial number: _____

Date of purchase: _____

Place of purchase: _____

Liquid Life is a trademark of Acer Incorporated. Google Play is a trademark of Google Inc.

TABLE OF CONTENTS

Leap Ware Quick Tips	4	Viewing the Leaderboard	18
Setting up	5	The Life Page	19
Unpacking your Acer Leap Ware	5	Leap Ware Settings	19
Charging the battery	5	Profile	19
Your Acer Leap Ware	6	Device	20
Changing the strap	7	Goals and Reminders	20
Care and wearing tips	7	Daily Reminders	21
Pairing the Leap Ware with your phone	8	Endurance / Stamina	22
Download the Acer Liquid Life app	8	Tracking your activity	23
Set up the app	8	Wearing your Leap Ware	23
Pairing	9	Track your physical activity	23
Sync with the app	9	Step tracker (steps / calories / distance) ..	23
Using the Leap Ware	10	Heart rate measurement	24
Navigation	10	Running and cycling trackers	25
Navigation tips	10	Stamina	27
Clock and activity	11	UV meter	28
Notifications	11	Stress and fatigue	29
Music	11	Troubleshooting	30
Snapshot	12	Specifications	33
Stopwatch	12	OS	33
Settings	12	Display	33
UV meter	13	Memory	33
World Clock	13	Connectivity	33
Flashlight / torch	13	Sensors	33
Reminders	14	Water resistance	33
App notifications	14	Notification	34
Your Acer Liquid Life app	15	Battery	34
Your Profile	15	System requirements	34
My Groups	16	Dimensions	34
Creating a group	16	Weight	34
Joining a group	17	Certification	34
Viewing a group	17	Compatibility	35
Leaving a group	18	End User License Agreement	36

LEAP WARE QUICK TIPS

Here are some quick tips to answer common questions. To get started now please **see Setting up on page 5**.

Setting up

To charge, connect the cable to a USB port on your computer or a certified USB charger (typically 5 V, 1 to 2 A - not included).

The *Leap Ware* will turn on automatically while charging. Otherwise press and hold the top-left button to turn the *Leap Ware* on or off.

See Charging the battery on page 5.

Wearing your Leap Ware

Make sure you remove the protective film from the back of the *Leap Ware* before wearing it.

As the flashlight / torch is on the right-side of the *Leap Ware*, please wear the device on your left wrist.

See Care and wearing tips on page 7.

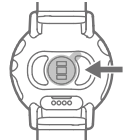

Buttons

Press the top-left button to turn on the backlight and display the clock.

Press the top-right button to just turn on the backlight.

See Your Acer Leap Ware on page 6.

Leap Ware screens

Swipe up or down to change options; tap to use. **See Navigation on page 10.**

- **Clock face** - **see Clock and activity on page 11.**

Tap to see connection and battery status. Swipe left or right to see activity tracking information and controls. *If you accidentally start the Running or Cycling tracker countdown, tap the screen to exit.*

- **Notifications** - **see Notifications on page 11.**
- **Music** - **see Music on page 11.**
- **Snapshot** - **see Snapshot on page 12.**
- **Stopwatch** - **see Stopwatch on page 12.**
- **Settings** - **see Settings on page 12.**

Tip: Swipe right from *Settings* to activate the *Phone Finder*.

- **UV meter** - **see UV meter on page 13.**
- **World Clock** - **see World Clock on page 13.**
- **Flashlight / torch** - **see Flashlight / torch on page 13.**

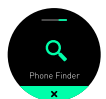

SETTING UP

Unpacking your Acer Leap Ware

Your new *Acer Leap Ware* comes packed in a protective box. Carefully unpack the contents of the box. If any of the following items are missing or damaged, contact your dealer immediately:

- Your new *Acer Leap Ware* device
- Charging cable
- Quick Guide

Charging the battery

For first use, you need to charge your *Leap Ware* for approximately 150 minutes. After the first full charge, you can charge it as necessary.

1. Attach the USB cable to the *Leap Ware*, lining up the charging connectors. Ensure the cable is orientated correctly and clicks into place; the cable is held in place with a pair of magnets.

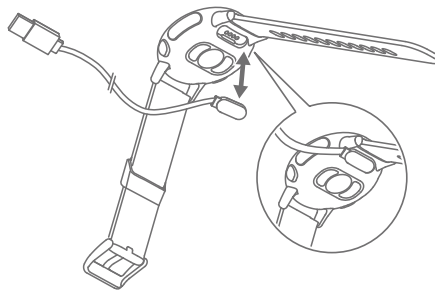

Note

*The Leap Ware will turn on automatically after charging for 15 seconds. For first use, the Leap Ware **must** charge before it will turn on.*

2. Connect the cable to a USB port on your computer or a certified USB charger (typically 5 V, 1 to 2 A - not included).



Note

Use only a charger that complies with national safety standards. Using other chargers may damage the device and risks injury and property damage.

3. The first time you charge your *Leap Ware*, wait for about 150 minutes to ensure a full charge.



Note

If your Leap Ware has not yet been paired with your phone, the battery gauge is replaced with the Acer Liquid Life download QR code.

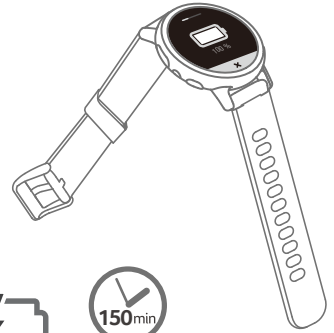

Your Acer Leap Ware

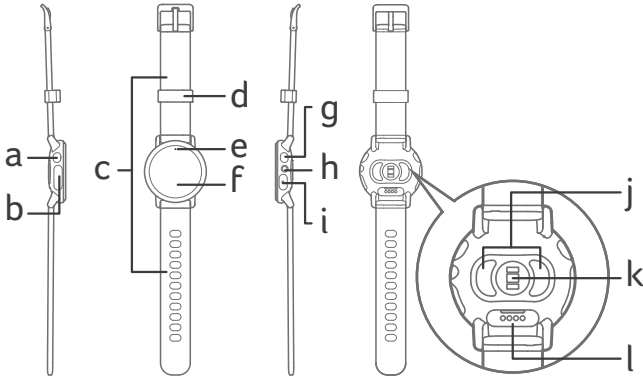

a. Home key

Return to the clock and turn on the backlight.

Press and hold: power on / off (hold for 2-3 seconds to turn on, hold for 8 seconds to turn off).

b. Electrode pad

c. Strap

d. Strap loop

e. UV meter

f. Touch screen

Tap and hold: turn on the backlight.

g. Quick key

*Turn on the backlight
Add a second function in the Device section of the Liquid Life app.*

h. Flashlight / torch

i. Electrode pad

j. Electrode pads

k. Heart rate sensor

Make sure you remove the protective film.

l. Charging pins



Changing the strap

You may change the strap attached to the *Leap Ware*.

Open the spring latch at the top of both straps to remove the old strap.

1. Slide one end of the spring bar of the new strap into the hole in the watch body.
2. Use the latch to retract the pin on the spring bar.
3. Slide the strap into position and release the latch so the strap locks into place.
4. Repeat for the second part of the strap.

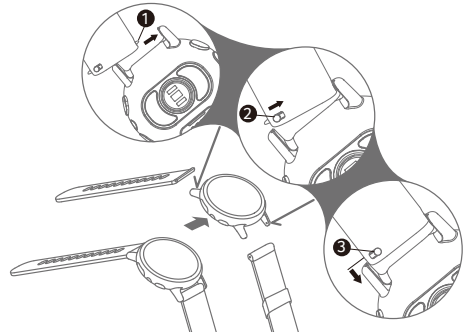

Care and wearing tips

- When using the flashlight, wear the device on your left wrist.
- Position the *Leap Ware* so the strap is two finger-widths from the base of your palm. The face should be a short distance from your wrist bone (ulna).
- To improve the accuracy of readings, attach the strap tightly, so the pads on the underside of the *Leap Ware* are held firmly against your wrist.
- Do not submerge the *Leap Ware* or wear while swimming.
- If you notice any signs of skin irritation or experience any discomfort, please remove or move the *Leap Ware* until your skin recovers.

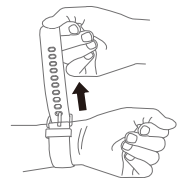
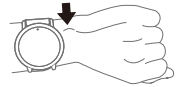

Important

The *Leap Ware* is not a medical device. Readings taken by the *Leap Ware* are to promote a healthy lifestyle, and should not be used or relied on as a medical device to diagnose any medical condition or symptom.

Consult a physician before beginning any fitness program.

PAIRING THE LEAP WARE WITH YOUR PHONE

Download the Acer Liquid Life app

The *Acer Liquid Life* app gathers data from your *Leap Ware* and allows you to track activities that promote a healthy lifestyle, display notifications and compare activity with your friends.

Use your phone to scan the appropriate QR code, or open the *Play Store* or *App Store* and search for *Acer Liquid Life*.



Acer Liquid Life



Set up the app

Please install and open the app.

You must create an account, or, if you have used *Liquid Life* before, sign in with an existing *Liquid Life* account.

- Tap **SIGN IN**, then tap the box to agree to the license terms and privacy policy.
- Tap *Sign up a new account* to create a new account linked to your email address.
- If you are a returning *Liquid Life* user and signed up with an email address, tap **Email Address**.
- Or use Facebook or Google+ (your Google account) to sign in.

If this is the first time you have used the app, follow the instructions to create your profile.

By default your profile uses *metric* units, tap the *Units* option to change to *Imperial* units.

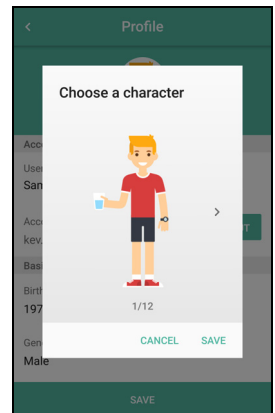

Pairing

After creating your profile, you should see a prompt to pair with the *Leap Ware*. Make sure the *Leap Ware* is ON and select **Yes** in the app. Follow the instructions.

- If you are not prompted to pair your *Leap Ware*, tap the settings icon in the top-left corner of your profile, then tap **Device > Pair**. Follow the instructions.



Note

You must allow the app to access Bluetooth. Your Leap Ware must be paired with the app, not through your phone's Bluetooth settings.

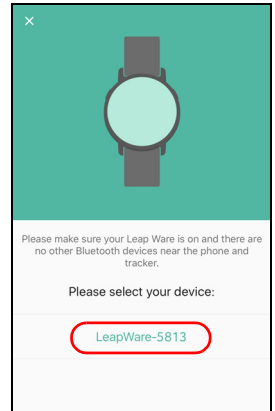

- Tap the name of your *Leap Ware* in the *Devices found* list (for example *LeapWare-5813*).

After pairing the app will instruct you on how best to wear the *Leap Ware* and track activities that promote a healthy lifestyle.



Note

For best results, attach the strap so the Leap Ware is held firmly against your wrist.



Note

*Acer does not guarantee that the Liquid Life app or Leap Ware will work with all Android or Apple devices. See **Compatibility on page 35** for a list of tested devices.*

Sync with the app

Your *Leap Ware* syncs over Bluetooth. Syncing occurs automatically while *Liquid Life* is active, as long as Bluetooth is enabled on your phone.



Note

*If your Leap Ware does not sync correctly with the Liquid Life app, see **My Leap Ware has been disconnected from my phone on page 30**.*

USING THE LEAP WARE

After you have paired your *Leap Ware* with your phone, it will automatically display the time and date provided by your phone.

- To turn the backlight on, tap and hold the screen, or press the left or right key (the left key will also return to the clock face).
To preserve battery, the screen backlight will turn off after about six seconds.
- Scroll through the features of your *Leap Ware* by swiping left/right, or up/down on the screen.
- Tap to select an item.

To return to the main screen (clock face) from any other screen, press the Home key (left key).



Note

*You may customize your Leap Ware from the Liquid Life app.
See Leap Ware Settings on page 19.*



Navigation

The default main screen shows the time and date.



Note

If the time displayed has not been updated recently, tap the screen to wake the Leap Ware and refresh the screen display.

Swipe up or down to see different *Leap Ware* functions, or swipe left or right to see activity tracking features.

Navigation tips

Except on the clock screen, you will see small dots at the edge of most screens, either at the top and bottom, or left and right. Swipe towards a dot to switch to the next screen.

If the option provides additional controls, tap the screen to display them; tap an icon or text to use that control, or the **x** to exit.

Clock and activity

The default main screen shows the time and date. Tap to see connection and battery status.

Swipe left or right to see activity tracking information and controls; swipe up or down to change functions.

See Tracking your activity on page 23.

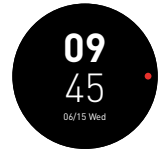

Note

To save energy, the clock will not refresh if your Leap Ware detects no activity for a while. Simply tap the screen to wake the display.

Notifications

Swipe up from the main screen to see if you have received any messages.

Tap to see an unread message, missed call, or app notification. **See App notifications on page 14.**



Music

Swipe up again and tap to open the music remote control.

If a compatible music app is open on your phone, tap the control symbols to control playback. Tap the volume symbol to open the volume control. Tap the **x** to exit.

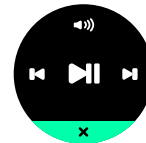
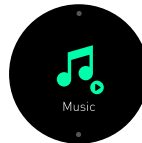

Note

Acer does not guarantee that the Music remote control will work with all Android or Apple devices.

Snapshot

Swipe up again and tap to open the camera shutter remote control.

If a compatible camera app is open on your phone, you can tap the circle to take a photo. Tap the **x** to exit.

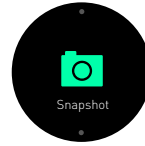

Note

Acer does not guarantee that Snapshot will work with all Android or Apple devices.

Stopwatch

Swipe up again and tap to open the stopwatch.

Tap the *Play* button at the top of the screen to start the stopwatch, and tap the *Pause* button to stop the timer; press *Play* to restart, or *Stop* to clear the time. Tap the **x** to exit.

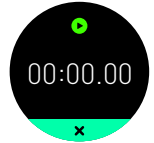

Settings

Swipe up again and tap to open Settings.

The first screen shows the battery level, swipe left or right to see: device information (including regulatory information), factory reset, or the *Phone Finder*.



Phone Finder

Open the *Settings* screen then swipe right. Tap the **Phone Finder** icon to sound an alarm on your phone (your phone must be within Bluetooth range).

Unlock your phone to stop the alarm.

A message is shown on the *Leap Ware* if the phone cannot be found because it is out of Bluetooth range, powered off, or Bluetooth is off.



UV meter

Swipe up again to start the UV meter.

The UV meter will measure the ambient UV intensity and displays a rating indicating UV intensity, from low to high.

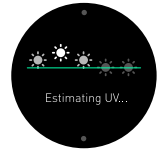

Note

Do not block the meter (above the touchscreen) while it is active. The meter must be in direct sunlight and point towards the sun.

World Clock

Swipe up again and tap to see the World Clock.

This screen shows the time in the time zone selected in the *Liquid Life* app.

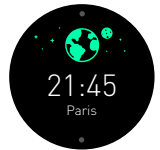

Note

*To change the World Clock zone, in the Liquid Life app, tap the Settings icon then the name of your Leap Ware under Device. Finally select **World Clock** then an appropriate city / time zone from the list.*

Flashlight / torch

Swipe up again and tap to see the flashlight / torch controls for the light on the right side of the *Leap Ware*.

- Tap SOS to blink the morse code for 'SOS'.
 - Tap the middle icon to turn the light on.
 - Tap the right-side icon to flash the light repeatedly.
- Tap the icon again to turn off the light.



Note

As the light is on the right-side of the Leap Ware, please wear the device on your left wrist, or remove the device temporarily.

Reminders

If you have set up reminders for water, weight, or medicine, your *Leap Ware* will vibrate and display a reminder at the set time. **See Goals and Reminders on page 20.**

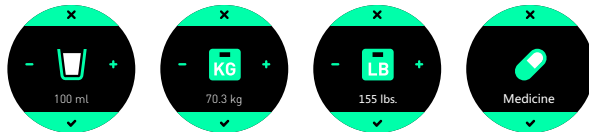

If the reminder is a measurement (water or weight), you may update these directly from your *Leap Ware*. Tap the - or + symbols to change the value, then tap the check mark to update the value.



Note

To set goals and reminders, and change notifications, open the Liquid Life app, then tap the Settings icon. Scroll down to the Goal and Reminders section and tap the entry you want to adjust.

App notifications

You may choose to display messages or notifications from a selection of compatible apps installed on your phone.

To allow apps to send notifications, open the *Liquid Life* app, tap the **Settings** icon then the name of your *Leap Ware* in the *Device* section. Select **Notifications** then tap to turn notifications from each app on or off. For example, select **Phone** to see call notifications from the *Phone* app.



Note

*You may be asked to allow Liquid Life to read and/or generate notifications on your phone. Make sure Liquid Life is selected, or select **Allow**.*



Important

You will only receive notifications if your phone and Leap Ware are turned on and connected.

If the Leap Ware and phone are disconnected, then reconnected, stored notifications will be lost.

YOUR ACER LIQUID LIFE APP

Your Profile

The *Profile* screen shows your character image (avatar), current status and tracks your progress towards goals.

Labels around your character image show your water consumption, stress level, heart rate, weight, UV reading and activity (steps). An additional label shows the UV forecast for your location.

Tap these labels to see more information, such as a Daily / Weekly / Monthly record. For example, tap the *Heart rate* label to see a history of heart rate readings. **See Track activity in the Liquid Life app on page 27.**

At the top of the screen three icons allow you to open the *Settings* screen (page 19), activate or see your Endurance level (page 22), and to share your profile as an image.

Tap the + icon in the bottom-right corner to update water intake or your weight.

Swipe left to see *My Groups* (page 16) or right to see the *Life Page* (page 19).

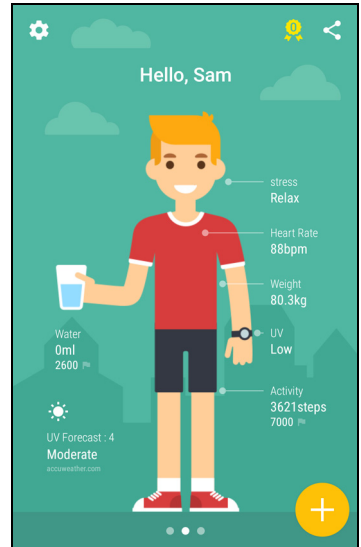

Note

Using your phone's sensors, the Liquid Life app can track your steps when not paired to a Leap Ware. However, the step count may be less accurate.

My Groups

Swipe left from the *Profile* screen to open the *My Groups* screen.

My Groups allows you to create up to three groups to compare progress, or compete, with your friends or rivals. Each group may contain up to ten members, sharing profile information, and gives access to a weekly or monthly activity leaderboard.

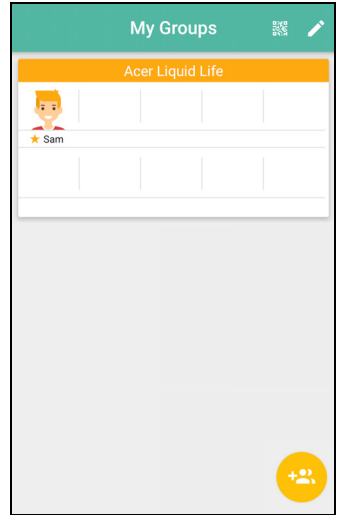

Creating a group

You may create your own group and ask friends to join.

Tap the *Add group* icon in the bottom-right corner of the *My Group* screen and enter a descriptive name for the group. All members will see this name.



You may then choose which information will be shared in the group (Steps, Weight, Water, Heart rate, Stress, UV, and Eyestrain). Tap on each item to select it - selected items will be outlined. Tap **OK** to create the group.

You may now ask friends with the *Liquid Life* app to join your group, using either their account email address, or by scanning a QR code displayed on their phone.

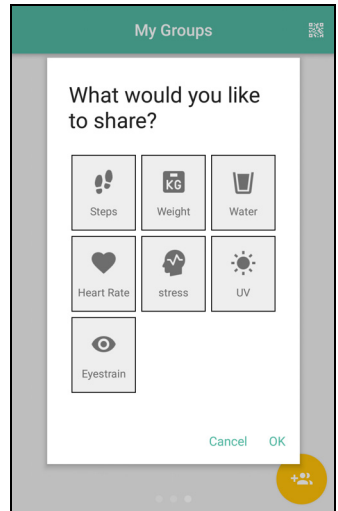

Joining a group

If a friend with the *Liquid Life* app has set up a group and has their phone, simply open the My Groups screen in your *Liquid Life* app and tap the QR code icon at the top of the screen.

The group creator must scan the code from your phone's screen (open the group in their *Liquid Life* app and tap **Add** at the bottom of the screen, then **By QR code**).

Alternatively, if you used your email address to create your account, the group creator can add you by selecting **By Account**. They can enter your email address and tap the *Search* icon.

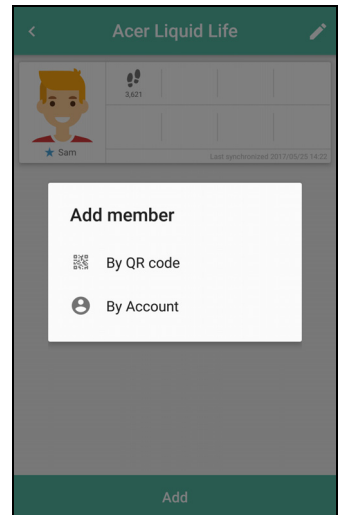

Note

You may join up to three groups in the free version of the *Liquid Life* app.

Viewing a group

After joining or creating a group, you will see a group summary with ten slots in the *My Groups* screen. The summary shows the character icon and name of each member.



Note

A star is shown next to the name of the group owner/creator.

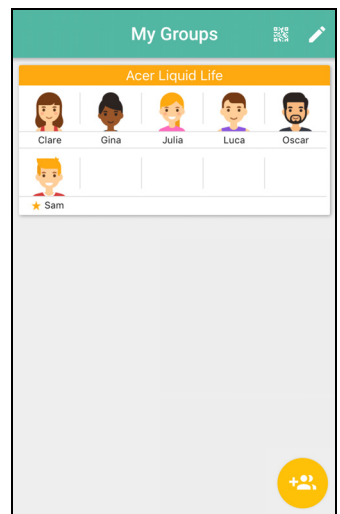

Tap on the group to see more information. A tile for each member shows the shared information. If there are more than four members, swipe up or down to see tiles for all the members of the group.



Note

The group owner/creator may select which information is shown. This is done when the group is created, or may be changed by opening the group and tapping the edit icon.

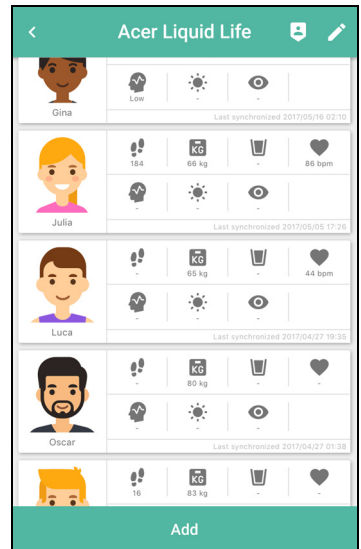

Leaving a group

You may leave a group at any time. Open the group and tap the *Exit* icon, then select **Delete**.

A group owner/creator may also remove members. Open a group you created, and tap the *Edit* icon; tap the *Delete* icon next to the name of the member to be removed.

Viewing the Leaderboard

You may view a weekly or monthly activity leaderboard for each group. Top-ranked group members will be shown on a track, the position of each character image representing their total steps for the time period. Below the track a list shows all members, ranked by total steps taken over the selected period.



Note

A member's position on the leaderboard is not available until they have recorded at least a full week's activity (Sunday to Saturday). If no members have completed a full week, the leaderboard is not available.

The Life Page

Swipe right from the *Profile* screen to open the *Life Page* screen.

The *Life Page* shows a selection of health, lifestyle and well-being stories that may help, inform or inspire you.

The *News* tab shows articles you may read taken from a variety of sources. The *Video* tab provides video articles for well-being.

Tap the *Bookmark* icon to save an item for future reference; your bookmark choices will be used to customise the lists to better match your interests. Tap the *Share* icon to send the item to another app.

Tap the *Menu* icon (in the top-left corner), then select **Bookmarks** to see your bookmarked articles.



Leap Ware Settings

You may customize your *Leap Ware* from the *Liquid Life* app. Tap the **Settings** icon in the top-left corner of the main screen.

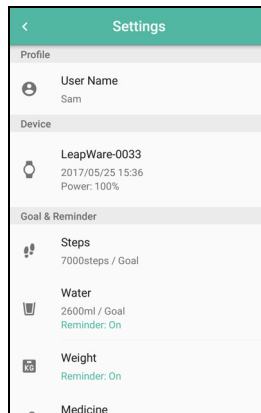

Profile

Tap **User Name** to access your profile.

Adjust your profile here, including your character image, account and basic physical information.



Device

Tap the name of your *Leap Ware* under the *Device* section, you may then tap a section to adjust your phone's and *Leap Ware*'s behaviors.



Tap the menu icon in the top corner to see links to video tutorials or download the latest User's Manual.



- LeapWare-XXXX
You may check the connection or **Unpair** your *Leap Ware*.
- Clock Face
Choose a new look for the clock face on the main screen.
- World Clock
Choose a time zone to show in the World Clock page.
- Quick Key
Adjust the function of the Quick Key.
- Theme
Choose the highlight color for *Leap Ware* graphics.
- Notifications
Choose which apps can generate a notification on your *Leap Ware*.
See App notifications on page 14.
- Firmware version
Shows the version of the firmware installed on the *Leap Ware*. Tap to check you are using the latest version.
- Serial Number
Shows the serial number of your *Leap Ware*. This may be needed if you contact the Acer service center.

Goals and Reminders

Set your goals and reminders in this section.

Your goals are visible on the main profile page. The initial values are determined from the information entered in your profile, but you may adjust the values for a more, or less, challenging routine, or to more accurately reflect your personal constraints and advice from health or training professionals.



- Tap on **Steps** or **Water** to adjust the daily targets.

- You may add reminders to drink water, check your weight, or take medicine. These will be displayed on your *Leap Ware*. **See Reminders on page 14.**

Daily Reminders

The *Liquid Life* app can display reminders and notifications on your phone (not all notifications or reminders are available in iOS versions of the app).

Steps & Calories: See a notification tile with your daily step progress.

Goal achieved: Receive a notification when you reach a goal.

Eye Care: Regular reminders to take a break if viewing a screen.

- If the smartphone screen is on continuously for 30 minutes, your smartphone will display an eye care notification.
- A second notification will be displayed after an hour.

UV Forecast: Display alerts if high UV levels are forecast for your location.

Endurance / Stamina

The *Liquid Life* app provides an estimation of your Endurance and Stamina.

Tap the *Level* icon on the profile screen. The *Endurance* screen shows your current level with a badge and level title.



To provide a base level, you must first determine your resting heart rate. Check the instructions and tap **Start**.

After your resting heart rate has been recorded, whenever you use the running tracker and run for more than 20 minutes the app will assess your performance (based on your heart rate) and determine your Stamina level. **See Running and cycling trackers on page 25.**

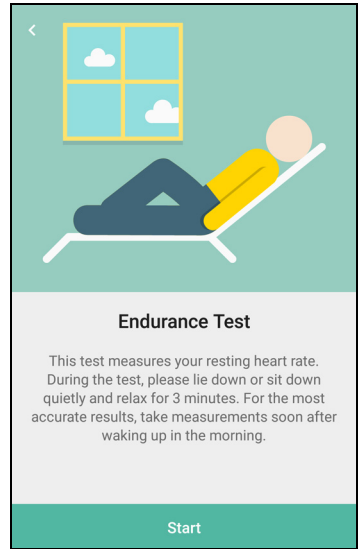

Note

While running, keep your phone with you, with an active data connection, so the Leap Ware can continuously transmit information to the app and provide assessments.



Note

*For an accurate assessment, periodically update your resting heart rate information: from the Profile screen, tap **Heart Rate**, then tap the arrow in the **Resting HR** section. Follow the instructions.*



Note

The Leap Ware includes two years free access to the Endurance/ Stamina program.

TRACKING YOUR ACTIVITY

Your *Leap Ware* can track your activity and with the *Liquid Life* app you can follow trends in your lifestyle.

Wearing your Leap Ware

To obtain consistent results, your *Leap Ware* must be able to take good readings from a consistent position on your wrist. **See Care and wearing tips on page 7.**

- For a small set of users, the *Leap Ware* will be unable to take measurements. **See Heart rate measurement on page 24.**

Track your physical activity

The default main screen shows the time and date. Swipe left or right to see activity tracking options.

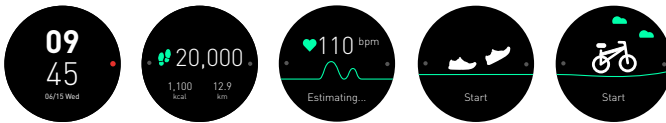

- Step tracker (steps / calories / distance).
- Heart rate measurement
- Running and cycling trackers

Step tracker (steps / calories / distance)

The three values indicate how many steps you have taken during the day, how many calories this represents and the estimated distance covered by these steps.

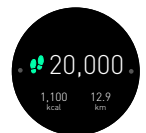

Note

Tap the screen to change which of the readings are shown in the center of the screen.

If you reach the goal set in the *Liquid Life* app, the *Leap Ware* will display a notification.

The reading resets at midnight and are stored by the *Liquid Life* app so you may track trends in your activity.

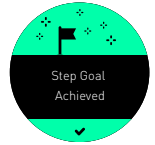

Heart rate measurement

The *Leap Ware* will automatically estimate your heart rate when you switch to the heart rate screen. After it has finished, tap **Start** to estimate again.

The *Leap Ware* also estimates your heart rate every 60 minutes (tap *Heart rate* in the *Liquid Life* app); when you perform stamina tests; and when using the running or cycling tracker.

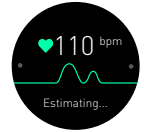

What is your heart rate?

Your heart rate, or pulse counts the number of times your heart beats per minute. Normal heart rate varies from person to person and varies according to your current activity and fitness.

Heart rate measurement

The *Leap Ware* flashes an LED many times per second and measures reflected light to detect the flow of blood at any given moment. Each heart beat changes the flow of blood and these changes are used to calculate your heart rate.

Make sure you are wearing the *Leap Ware* correctly to get the best measurements. **See [Wearing your Leap Ware on page 23](#).**

- For best results relax your wrist and stay still for 10-15 seconds.
- High-intensity training will increase your heart rate and may cause erratic readings. Please rest before taking measurements.

Results may vary for many reasons, including:

- Sharp, erratic movements, such as high-intensity training.
- Skin thickness and condition, and overall wrist thickness.
- Cold weather.
- A tattoo or other skin covering can block light from the sensor.

Running and cycling trackers

The *Leap Ware* shows the real-time stamina while exercising (**see Stamina on page 27**), and tells you when you reach the fat-burn zone based on your heart rate. This gives you more understanding of your pace.



When you are ready to exercise, swipe to either the running or cycling screen, and tap. You will see a countdown before the main tracker starts.

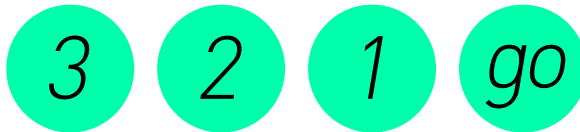

Note

Keep your phone with you so the Leap Ware can continuously transmit information to the app.

If you accidentally start the countdown, tap the screen to exit.

You will see a screen showing the distance covered, duration and your heart rate.



Note

Tap the screen to change which of the readings are shown in the center of the screen.

Real-time stamina

You *Leap Ware* lets you know how your workout is going. Stamina, heart rate, workout duration/distance, and calories burned can be displayed in real-time for more effective work out sessions.



Note

If you do not have your phone, or it is not connected to the Leap Ware, the outer circle will be grey and the real-time stamina countdown will not be available.

Exercise mode determines your *Fat Burn* zone from your profile information and current heart rate. **See Estimating Stamina on page 28.**

Resting and stopping

To rest, tap the *pause* icon at the top of the screen, then the play icon to start again.

To exit the tracker, tap *pause*, then *stop*. To help make a more accurate estimate of your performance, you will be asked about your breathing and energy (if you are tired) after your run; tap a face to answer each question.

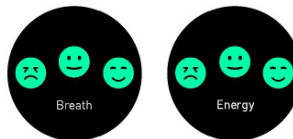

Note

If you do not have your phone, or it is not connected to the Leap Ware, you will not see these questions.

Track activity in the *Liquid Life* app

Check your progress and past performance in the app. Tap *Activity* from the *Profile* screen.

Your daily activity shows three tracks: steps, running and cycling. Your avatar shows the distance you have covered for each activity, swipe right to see a day-by-day history. Tap an character on the track to see more information; if you used the exercise tracker for running or cycling, tap **Details**, for more information, such as a map of your route.

Tap **Weekly** or **Monthly** at the top of the screen to see a graph of your activity over a longer period - swipe left or right on the graph to change the time period displayed.

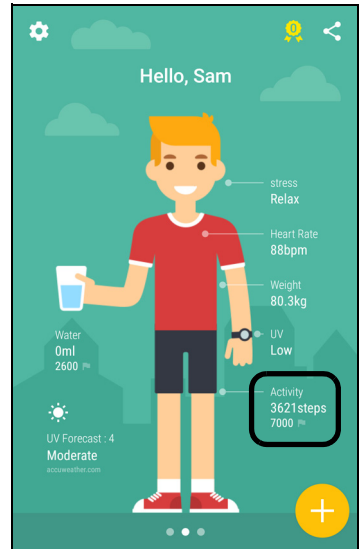

Calories burned

The *Liquid Life* app estimates how many calories you have burned and how much food that represents. Tap on the food icon to change the food type; choose from *Soft Serve* ice-cream, bottles of *Cola*, servings of *Popcorn*, or *Hamburgers*.

Stamina

What is stamina?

Stamina in this context represents the amount of energy required to sustain a high intensity workout. Stamina will recover if you take a break for a while or have an additional energy supply.

Stamina theory

When exercising, two types of energy systems are used: aerobic and anaerobic. Stamina represents a combination of aerobic and anaerobic energy systems. In a low-intensity workout, aerobic systems provide energy. In contrast, in a high-intensity workout, energy is supplemented by the faster anaerobic system.

Understanding how your body uses these two systems allows you to perform better in endurance exercises.

Estimating Stamina

The Stamina rating is based on information in your profile, such as gender, age, height and weight, with additional reference to daily step and heart rate measurements. While you are exercising, the green border around the *Leap Ware* screen indicates your current Stamina - a full green arc means your Stamina is at 100% and as your Stamina is used, the arc will gradually disappear.



UV meter

What is the UV meter?

The UV meter detects the intensity of ambient ultraviolet (UV) light. Prolonged exposure can damage your skin.



Estimating UV

The UV meter uses photodiodes to estimate ambient UV light. This adjusts automatically to differentiate between indoor or outdoor lighting.



Note

Do not block the meter (above the touchscreen) while it is active. The meter must be in direct sunlight and point towards the sun.

Detected UV levels are rated from *Low* to *Extreme*, rated from one to five sun icons. As the rating increases, take more precautions to protect yourself from the sun's rays, such as using sunscreen or staying in shade, especially in the middle of the day.

Stress and fatigue

What is Stress?

Stress is a reaction to physical, mental or emotional stimulus. It is not always a bad influence, but it can interfere with your health or physical state (for example: heart rate).

Fatigue may be associated with long-term stress, defined as physical or mental exhaustion. Fatigue dulls your senses, thought processes and reflexes.

The *Leap Ware* will display an alert if stress is detected.

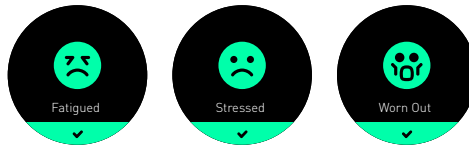

You may also check your current stress level on the profile screen in the *Liquid Life* app. Tap the **Stress** label to see recorded stress levels since you started wearing the *Leap Ware*.

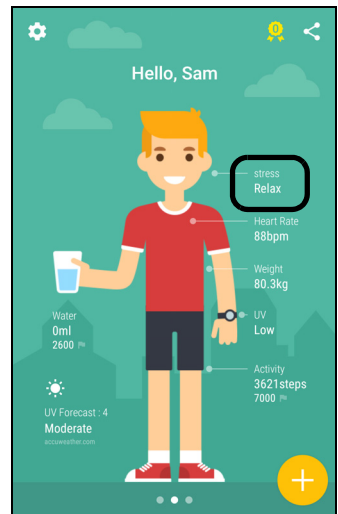

TROUBLESHOOTING

I can't connect my Leap Ware to my phone

Make sure both devices are on, Bluetooth is on and the devices are near each other.

If your *Leap Ware* does not connect with the *Liquid Life* app, please stop and restart Bluetooth on your phone, or restart your phone.

Please also check the **Compatibility** list on [page 35](#).

My Leap Ware has been disconnected from my phone

A *disconnected* icon is shown in the *Liquid Leap* app or notification tile if the *Leap Ware* is not connected.



If your *Leap Ware* is not connected to the *Liquid Life* app, stop and restart Bluetooth on your phone, restart your phone and/or restart the *Leap Wear*.

Alternatively, restart the app (in your phone's **Settings** > **Apps** > **Acer Liquid Life** > **Force stop**, then open the app).

If your *Leap Ware* is still disconnected, unpair the *Leap Ware* using *Acer Liquid Life* (in **Settings** > **Device**) and pair the devices again. [See Pairing on page 9](#).



Warning

If you unpair and pair your devices, you will lose data stored on the *Leap Ware*.

If you unpair while your *Leap Ware* device is not present, you should reset the *Leap Ware* before pairing the devices again (on the *Leap Ware*, open **Settings > **Factory Reset** > **Yes**).**

[See Pairing on page 9](#).

I can't control music playback

Try launching your device's music player and start playing a song. Now you should be able to control the music playback from the *Leap Ware*.

The *Leap Ware* will control apps that are compatible with Basic Music Control standards.

I can't control my camera

The *Snapshot* function might not work on some Android phones. Please check your camera app; *Snapshot* will only work if pressing the volume up or volume down button takes a photo. If the volume buttons do not work, check the camera app settings to see if you can change the volume button function.

If you can take photos with your phone's camera using the volume key, but the *Snapshot* function does not work, please follow these steps to activate *Snapshot*:

1. Pair the *Leap Ware* with *Liquid life*.
2. Open **Settings** on your phone.
3. Open **Bluetooth** settings.
4. In the *Available device list*, find the *Leap Ware* name in the list ("Leap Wear-xxxx" where xxxx = number).
5. For Android devices: Tap the settings button next to the *Leap Ware* name. Uncheck the *Input device* option and then check it again. Tap **OK** then the *Leap Ware* name and make sure it is *Paired*.
6. The *Snapshot* function should now work.

My Leap Ware has turned off

Your *Leap Ware* will automatically turn off if the battery level drops to about 1%, try charging it for at least 15 minutes before using it again.

Your *Leap Ware* will also turn off if the battery overheats. If your *Leap Ware* is unusually warm, allow it to cool before charging it. If the *Leap Ware* repeatedly overheats, please contact an authorized Acer service center.

How do I wake my Leap Ware up?

If you are having trouble waking your *Leap Ware* up, try charging it.

If it has been fully charged or still has power, tap the screen or press the Home key.

My Leap Ware won't turn on

Try charging your *Leap Ware*. It should turn on after a few minutes of charging.

If this doesn't help, please contact an authorized Acer service center.

My Leap Ware won't pair

Please make sure your smartphone's Bluetooth is enabled from your smartphone's Bluetooth settings. If you have just enabled Bluetooth, remove *Acer Liquid Life* from recent apps and launch it again.

If *Acer Liquid Life* says it cannot find your *Leap Ware*, please go to your smartphone's Bluetooth settings and look at the connected devices. You should see a device name starting with LeapWare. If it says *connected*, tap and hold the device name (or in iOS tap the (i) icon) and select **Forget this device** or **delete**. Return to *Acer Liquid Life* and connect again.

How do I remove the Leap Ware from my account?

Open *Acer Liquid Life*, open *Settings* and tap **Device**. You will see an *Unpair* button; tap to unpair your *Leap Ware*.

To pair a new device, **see Pairing the Leap Ware with your phone on page 8**.

How do I update my Leap Ware?

From time to time, there may be updates available for your *Leap Ware*. When you pair your *Leap Ware* with a phone, it will check for and apply updates.

If an update is available, you will receive an update notification and your *Leap Ware* will automatically update when it syncs with the app.

Ensure your smartphone and *Leap Ware* are sufficiently charged.

The UV rating is not accurate

Do not block the meter (above the touchscreen) while it is active. The meter must be in direct sunlight and point towards the sun.

SPECIFICATIONS

OS

Proprietary OS

Display

1.1" LCD transfective touchscreen
218 x 218 resolution (round)
Capacitive touch
64-color with backlight

Memory

4 MB flash
4 MB SRAM

Connectivity

Bluetooth 4.0 LE

Sensors

Three-dimensional accelerometer
UV meter
Heart rate sensors

Water resistance

Water resistant (IPX7)



Note

Do not submerge or wear while swimming.

Notification

Vibration

Battery

130 mAh rechargeable, non-user replaceable battery

Up to 5-days battery life

Charging via Pogo pins (USB)



Note

Battery life changes depending on use.

System requirements

Android 5.0 or higher

iOS 8.0 or higher

Bluetooth 4.0 (BLE)

Acer Liquid Life™ app

Dimensions

42 x 42 x 12.2 mm (without strap and strap attachments)

Weight

37 g

Certification

To view safety and regulatory information, open **Settings** on the device, swipe to **Device info**, tap then swipe left or right.

TRADEMARK INFORMATION

Liquid Life is a trademark of Acer Incorporated.

COMPATIBILITY

ACER

Liquid Z6 Plus

ASUS

ZenFone 2 Deluxe

ZenFone Selfie

ZenFone 2 Laser

Zenfone GO

ZenFone 2 Laser

ZenFone 3 ZE552KL

HTC

Butterfly S

One max 803s

One E9 dual sim

Desire 728 dual sim

One M9+

One M9

One M8

One X9 dual sim

One A9

Butterfly 3

Desire 530

10 (M10h)

Desire 826

HUAWEI

Mate 9

Mate 7

P9

G7 Plus

GOOGLE Nexus 6P

LG

Nexus 5X

G3

G4

V10

K10

G5

MEIZU

Meilan note

Pro 5

OnePlus

2 (A2001)

MOTO

Nexus 6

OPPO

R9s

Find 7

SAMSUNG

Galaxy S7

Galaxy S6

Galaxy S6 edge+

Galaxy S5

Galaxy A8

Galaxy Note 5

Galaxy Note 4

SONY

XPERIA Z2

XPERIA X Compact

VIVO

X9

X5Max

XIAOMI

Mi-4i

Mi-4c

RedMi 4

RedMi Note3

Note

4i

ZTE

Nubia Z11

Blade S6 Plus

BLADE V580

APPLE

iPhone 7

iPhone 6 Plus

iPhone 6S

iPhone 5s

iPhone 5C

iPhone 5



Note

*For the latest list of compatible devices, please go to:
go.acer.com/compatibility*

END USER LICENSE AGREEMENT

IMPORTANT-READ CAREFULLY: THIS END USER LICENSE AGREEMENT (THE "AGREEMENT") IS A LEGAL AGREEMENT BETWEEN YOU (EITHER A PERSON OR A ENTITY), AND ACER INC. INCLUDING ITS SUBSIDIARIES ("ACER") FOR THE SOFTWARE (WHETHER PROVIDED BY ACER AND/OR BY ACER'S THIRD-PARTY LICENSORS OR SUPPLIERS) THAT ACCOMPANIES THIS AGREEMENT AND/OR IS INCORPORATED INTO THE WEARABLE DEVICE (THE "WEARABLE"), INCLUDING ANY ASSOCIATED MEDIA, PRINTED MATERIALS AND RELATED USER ELECTRONIC DOCUMENTATION WHICH MAY BE BRANDED "ACER", "GATEWAY", "PACKARD BELL", OR "E-MACHINES" (COLLECTIVELY, THE "SOFTWARE"). AGREEMENTS RELATING TO ANY OTHER PRODUCT OR TOPIC ARE NEITHER INTENDED NOR SHOULD THEY BE IMPLIED. BY CLICKING ON THE "AGREE" BUTTON, BY INSTALLING OR ACTIVATING THE SOFTWARE OR ANY PORTION THEREOF, OR BY USING THE WEARABLE, AS APPLICABLE, YOU AGREE TO BE BOUND BY THE TERMS AND CONDITIONS OF THIS AGREEMENT. IF YOU DO NOT AGREE TO ALL OF THE TERMS AND CONDITIONS OF THIS AGREEMENT, DO NOT CONTINUE THE INSTALLATION OR ACTIVATION PROCESS OR THE USE OF THE WEARABLE, AND IMMEDIATELY DELETE ALL INSTALLED FILES, IF ANY, OF THE SOFTWARE FROM YOUR COMPUTER SYSTEM.

IF YOU DO NOT HAVE A VALIDLY-LICENSED COPY OF THE SOFTWARE, YOU ARE NOT AUTHORIZED TO INSTALL, COPY OR OTHERWISE USE THE SOFTWARE, AND HAVE NO RIGHTS UNDER THIS AGREEMENT.

The Software is protected by national and international copyright laws and conventions as well as other intellectual property laws and treaties. The Software is licensed, not sold.

GRANT OF LICENSE

Acer grants to you the following non-exclusive and non-transferable rights with respect to the Software. Under this Agreement, you may:

1. Install and use the Software in a single designated Wearable and/or portable device (the "Device"). A separate license is required for each Wearable or Device on which the Software will be used;
2. Make one copy of the Software solely for backup or archival purposes; and
3. Make one hardcopy of any electronic documents included in the Software, provided that you receive the documents electronically.

RESTRICTIONS

You shall NOT:

1. Use or copy the Software except as provided in this Agreement;
2. Rent or lease the Software to any third party;
3. Modify, adapt, or translate the Software in whole or in part;
4. Reverse engineer, decompile, or disassemble the Software or create derivative works based upon the Software;
5. Merge the Software with any other program or modify the Software, except for your personal use; and
6. Sublicense or otherwise make the Software available to third parties, except that you may, after prior written notification to Acer, transfer the Software as a whole to a third party so long as you do not retain any copies of the Software and such third party accepts the terms of this Agreement.
7. Transfer your rights under this Agreement to any third parties; and

8. Export the Software in contravention of applicable export laws and regulations, or (i) sell, re-export, transfer, divert, disclose technical data, or dispose of, any Software to any prohibited person, entity, or destination including, without limitation, Cuba, Iran, North Korea, Sudan and Syria; or (ii) use any Software for any use prohibited by applicable laws or regulations.

LIVE UPDATE

Certain of the Software contains elements that enable the use of the Acer Live Update service, which allows for updates for such Software to be automatically downloaded and installed on your Wearable and/or the Device. By installing the Software, you hereby agree and consent that Acer (or its licensors or suppliers) may automatically check the version of such Software that you are using on your Wearable and/or the Device and may provide upgrades to such Software that may be automatically downloaded on to your Wearable and/or the Device.

CONSENT TO USE OF DATA

You acknowledge and agree that Acer and/or Acer's contracted suppliers may collect and use personal information and other data (Collectively, the "Data") entered by you or created through the use of the Software and/or the Wearable as follows:

Account. In order to access and use the Software and the services performed by the Software (the "Service"), you must create a username and password and provide the information requested during the registration process. You are solely responsible for protecting the confidentiality of your username and password and for all activity that occurs using your username and password. If you become aware of any unauthorized use of your username or password, please notify Acer at ACER.SDPB.APP@acer.com as soon as possible.

Data. In order to use the Service, you will be required to provide (and Acer and/or Acer's contracted suppliers will collect once submitted) personal information including, but not limited to, your name, email address, birthdate, age, gender, height, and weight. Additional data will be generated (and collected by Acer and/or Acer's contracted suppliers) through the use of the Software and/or the Wearable including, but not limited to, performance details, usage statistics and patterns, location, operating system version, serial number identification, and language settings. Fitness activity data (such as steps, distance, pace, activity time, calories burned, heart rate, etc.) will be generated and stored onto your Account through the use of the Software and/or the Wearable. This enables you to analyze your fitness activity data, track your fitness goals, and, if you wish, share your fitness activity data with others. Acer and/or Acer's contracted suppliers will only use personal information and/or other data for the purpose of providing the Service, performing Software support, updates, and maintenance, and enhancing your experience.

Facilities and Data Transfer. Acer and/or Acer's contracted suppliers may process or store Data in, or transfer Data to or from, the United States, Europe, Taiwan, or any other location where Acer or Acer's contracted suppliers maintain facilities. By using the Software and/or the Wearable, you consent to the processing, storage and transfer of Data that may result in your Data being on (or transferred to) servers located outside the country where you live. Acer and/or Acer's contracted suppliers will take steps reasonably necessary to ensure that your Data is secure.

For more information on how your Data will be collected and used, please refer to Acer's Privacy Policy at: <http://www.acer-group.com/public/index/privacy.htm>

OWNERSHIP & COPYRIGHT

Title, ownership rights and intellectual property rights in and to the Software and all copies thereof shall remain with Acer (or Acer's licensors or suppliers) (as applicable). You do not have or shall not gain any proprietary interest in the Software (including any modifications or copies made by or for you) or any related intellectual property rights. Title and related rights in the content accessed through the Software is the property of the applicable content owner and may be protected by applicable law. This license gives you no rights to such contents. You hereby agree

1. Not to remove any copyright or other proprietary notices from the Software;
2. To reproduce all such notices on any authorized copies you make; and
3. To use best efforts to prevent any unauthorized copying of the Software.

TRADEMARKS

This Agreement does not grant to you any rights in connection with any trademarks or service marks of Acer or of Acer's licensors or suppliers.

DISCLAIMER OF WARRANTIES

THE WEARABLE AND THE SOFTWARE MAY CONTAIN FUNCTIONS TO ENCOURAGE FITNESS. YOU ACKNOWLEDGE AND AGREE THAT THE WEARABLE AND THE SOFTWARE HAVE NOT BEEN DESIGNED AND DEVELOPED TO MEET YOUR INDIVIDUAL NEEDS, AND IS NOT INTENDED TO BE USED FOR MEDICAL OR DIAGNOSTIC PURPOSE. INFORMATION OR DATA DERIVED FROM THE SOFTWARE IS FOR FITNESS PURPOSE ONLY AND SHALL NOT REPLACE THE MEDICAL ADVICE OF YOUR PHYSICIAN OR HEALTH CARE PROVIDOR. YOU ARE PARTICULARLY AWARE THAT COUNTING OR CALCULATION ERRORS MAY OCCUR WHEN USING THE SOFTWARE AND THE WEARABLE.

TO THE MAXIMUM EXTENT PERMITTED BY APPLICABLE LAW, ACER, ITS SUPPLIERS, AND ITS LICENSORS, PROVIDE THE SOFTWARE OR THE SERVICES "AS IS" AND WITH ALL FAULTS, AND HEREBY DISCLAIM ALL OTHER WARRANTIES AND CONDITIONS, EITHER EXPRESS, IMPLIED OR STATUTORY, INCLUDING, BUT NOT LIMITED TO, ANY IMPLIED WARRANTIES, DUTIES OR CONDITIONS OF MERCHANTABILITY, OF FITNESS FOR A PARTICULAR PURPOSE, OF ACCURACY OR COMPLETENESS OF RESPONSES, OF RESULTS, OF WORKMANLIKE EFFORT, OF LACK OF VIRUSES, AND OF LACK OF NEGLIGENCE, ALL WITH REGARD TO THE SOFTWARE AND THE PROVISION OF OR FAILURE TO PROVIDE SUPPORT SERVICES. ALSO, THERE IS NO WARRANTY OR CONDITION OF TITLE, QUIET ENJOYMENT, QUIET POSSESSION, CORRESPONDENCE TO DESCRIPTION OR NON-INFRINGEMENT WITH REGARD TO THE SOFTWARE.

THE SOFTWARE MAY INCLUDE LINKS OR ENABLE ACCESS TO CERTAIN THIRD PARTY WEBSITES AND/OR SERVICE (COLLECTIVELY, "THIRD PARTY SERVICES"). YOUR USE OF THIRD PARTY SERVICES MAY BE SUBJECT TO ADDITIONAL TERMS AND CONDITIONS REQUIRED BY THE THIRD PARTY OWNERS/LICENSORS OF SUCH SERVICES. CERTAIN CONTENT, INFORMATION, APPLICATIONS, OR MATERIALS MAY BE DISPLAYED OR MADE AVAILABLE ON OR THROUGH SUCH THIRD PARTY SERVICES (COLLECTIVELY, "THIRD PARTY MATERIALS"). THESE THIRD PARTY MATERIALS ARE NOT CONTROLLED BY ACER. YOU ACKNOWLEDGE AND AGREE THAT ACER DOES NOT ENDORSE AND IS NOT RESPONSIBLE FOR ANY THIRD PARTY SERVICES OR THIRD PARTY MATERIALS. THE LINKS OR ACCESS TO THIRD PARTY SERVICES AND THIRD PARTY MATERIALS ARE PROVIDED TO YOU SOLELY AS A CONVENIENCE. TO THE MAXIMUM EXTENT PERMITTED BY APPLICABLE LAW, ACER DISCLAIMS ANY AND ALL WARRANTIES OR REPRESENTATIONS PERTAINING TO THIRD PARTY SERVICES OR THIRD PARTY MATERIALS.

EXCLUSION OF INCIDENTAL, CONSEQUENTIAL AND CERTAIN OTHER DAMAGES

TO THE MAXIMUM EXTENT PERMITTED BY APPLICABLE LAW, IN NO EVENT SHALL ACER, ACER'S SUPPLIERS, OR ACER'S LICENSORS, BE LIABLE FOR ANY SPECIAL, INCIDENTAL, INDIRECT, PUNITIVE, OR CONSEQUENTIAL DAMAGES WHATSOEVER (INCLUDING, BUT NOT LIMITED TO, DAMAGES FOR LOSS OF PROFITS OR CONFIDENTIAL OR OTHER INFORMATION, FOR BUSINESS INTERRUPTION, FOR PERSONAL INJURY, FOR LOSS OF PRIVACY, FOR FAILURE TO MEET ANY DUTY INCLUDING OF GOOD FAITH OR OF REASONABLE CARE, FOR NEGLIGENCE, AND FOR ANY OTHER PECUNIARY OR OTHER LOSS WHATSOEVER) ARISING OUT OF OR IN ANY WAY RELATED TO THE USE OF OR

INABILITY TO USE THE SOFTWARE, THE PROVISION OF OR FAILURE TO PROVIDE SUPPORT SERVICES, OR OTHERWISE UNDER OR IN CONNECTION WITH ANY PROVISION OF THIS AGREEMENT, EVEN IN THE EVENT OF THE FAULT, TORT (INCLUDING NEGLIGENCE), STRICT LIABILITY, BREACH OF CONTRACT OR BREACH OF WARRANTY OF ACER OR ITS SUPPLIERS OR LICENSORS, AND EVEN IF ACER AND ITS SUPPLIERS AND LICENSORS HAVE BEEN ADVISED OF THE POSSIBILITY OF SUCH DAMAGES.

LIMITATION OF LIABILITY AND REMEDIES

NOTWITHSTANDING ANY DAMAGES THAT YOU MIGHT INCUR FOR ANY REASON WHATSOEVER (INCLUDING, WITHOUT LIMITATION, ALL DAMAGES REFERENCED ABOVE AND ALL DIRECT OR GENERAL DAMAGES), THE ENTIRE LIABILITY OF ACER, ITS SUPPLIERS, AND ITS LICENSORS, UNDER ANY PROVISION OF THIS AGREEMENT, AND YOUR EXCLUSIVE REMEDY FOR ALL OF THE FOREGOING, SHALL BE LIMITED TO THE AGGREGATE AMOUNT PAID BY YOU FOR THE SOFTWARE. THE FOREGOING LIMITATIONS, EXCLUSIONS AND DISCLAIMERS (INCLUDING DISCLAIMER OF WARRANTIES AND EXCLUSION OF INCIDENTAL, CONSEQUENTIAL AND CERTAIN OTHER DAMAGES ABOVE) SHALL APPLY TO THE MAXIMUM EXTENT PERMITTED BY APPLICABLE LAW, EVEN IF ANY REMEDY FAILS ITS ESSENTIAL PURPOSE; PROVIDED, HOWEVER, THAT BECAUSE SOME JURISDICTIONS DO NOT ALLOW THE EXCLUSION OR LIMITATION OF LIABILITY FOR CONSEQUENTIAL OR INCIDENTAL DAMAGES, THE ABOVE LIMITATION MAY NOT APPLY TO YOU.

TERMINATION

Without prejudice to any other rights, Acer may immediately terminate this Agreement without notice if you fail to comply with any terms and conditions of this Agreement.

In such event, you must:

1. Cease all use of the Software;
2. Destroy or return to Acer the original and all copies of the Software; and
3. Delete the Software from all computers on which it was resident.

All disclaimers of warranties and limitation of liability set forth in this Agreement shall survive termination of this Agreement.

GENERAL

This Agreement represents the complete agreement between you and Acer relating to this license for the Software and supersedes all prior agreements, communications, proposals and representations between the parties and prevails over any conflicting or additional terms of any quote, order, acknowledgement or similar communication. This Agreement may only be modified by a written document signed by both parties. If any provision of this Agreement is held by a court of competent jurisdiction to be contrary to law that provision will be enforced to the maximum extent permissible and the remaining provisions of this Agreement will remain in full force and effect.

ADDITIONAL PROVISIONS APPLICABLE TO THIRD PARTY SOFTWARE

Software provided hereunder by Acer's licensors or suppliers ("Third Party Software") is made available to you for your personal, non-commercial use only. You may not use the Third Party Software in any manner that could damage, disable, overburden, or impair the Services. Furthermore, you may not use the Third Party Software in any manner that could interfere with any other party's use and enjoyment of the Third Party Services, or other services and products of Acer's licensors' or suppliers' third party licensors. Your use of the Third Party Software shall also be subject to additional terms and conditions and policies which can be accessed through our global website at <http://www.acer.com/worldwide/support/swa.htm>.

Free Manuals Download Website

<http://myh66.com>

<http://usermanuals.us>

<http://www.somanuals.com>

<http://www.4manuals.cc>

<http://www.manual-lib.com>

<http://www.404manual.com>

<http://www.luxmanual.com>

<http://aubethermostatmanual.com>

Golf course search by state

<http://golfingnear.com>

Email search by domain

<http://emailbydomain.com>

Auto manuals search

<http://auto.somanuals.com>

TV manuals search

<http://tv.somanuals.com>