

PD100 / PD120
Service Guide

Service guide files and updates are available on the AIPG/CSD web; for more information, please refer to <http://csd.acer.com.tw>

Revision History

Please refer to the table below for the updates made on PD100 / PD120 service guide.

Date	Chapter	Updates

Copyright

Copyright © 2005 by Acer Incorporated. All rights reserved. No part of this publication may be reproduced, transmitted, transcribed, stored in a retrieval system, or translated into any language or computer language, in any form or by any means, electronic, mechanical, magnetic, optical, chemical, manual or otherwise, without the prior written permission of Acer Incorporated.

Disclaimer

The information in this guide is subject to change without notice.

Acer Incorporated makes no representations or warranties, either expressed or implied, with respect to the contents hereof and specifically disclaims any warranties of merchantability or fitness for any particular purpose. Any Acer Incorporated software described in this manual is sold or licensed "as is". Should the programs prove defective following their purchase, the buyer (and not Acer Incorporated, its distributor, or its dealer) assumes the entire cost of all necessary servicing, repair, and any incidental or consequential damages resulting from any defect in the software.

Acer is a registered trademark of Acer Corporation.

Intel is a registered trademark of Intel Corporation.

Pentium 4 and Celeron are trademarks of Intel Corporation.

Other brand and product names are trademarks and/or registered trademarks of their respective holders.

Conventions

The following conventions are used in this manual:

Screen messages	Denotes actual messages that appear on screen.
NOTE	Gives bits and pieces of additional information related to the current topic.
WARNING	Alerts you to any damage that might result from doing or not doing specific actions.
CAUTION	Gives precautionary measures to avoid possible hardware or software problems.
IMPORTANT	Reminds you to do specific actions relevant to the accomplishment of procedures.

Preface

Before using this information and the product it supports, please read the following general information.

1. This Service Guide provides you with all technical information relating to the BASIC CONFIGURATION decided for Acer's "global" product offering. To better fit local market requirements and enhance product competitiveness, your regional office MAY have decided to extend the functionality of a machine (e.g. add-on card, modem, or extra memory capability). These LOCALIZED FEATURES will NOT be covered in this generic service guide. In such cases, please contact your regional offices or the responsible personnel/channel to provide you with further technical details.
2. Please note WHEN ORDERING FRU PARTS, that you should check the most up-to-date information available on your regional web or channel. If, for whatever reason, a part number change is made, it will not be noted in the printed Service Guide. For ACER-AUTHORIZED SERVICE PROVIDERS, your Acer office may have a DIFFERENT part number code to those given in the FRU list of this printed Service Guide. You MUST use the list provided by your regional Acer office to order FRU parts for repair and service of customer machines.

Table of Contents

Chapter 1	System Introduction	1
	Technical Specification	1
	Product Overview	2
	System Block Diagram	6
Chapter 2	Firmware Upgrade	7
	Equipment Needed	7
	Installation Procedure	8
	Firmware Upgrade Procedure	12
	EDID Upgrade	15
	Equipment Needed	15
	Setup Procedure	16
	EDID Key-in Procedure	16
Chapter 3	Mechanical Disassembly and Reassembly	19
	Equipment Needed	19
	General Information	19
	Mechanical Disassembly Procedure	20
	Mechanical Reassembly Procedure	33
Chapter 4	Troubleshooting	46
	Equipment Needed	46
	LED Lighting Message	46
	Main Procedure	47
	Function Test and Alignment Procedure	49
	Product / Test Equipment / Test Condition	49
	Inspection Procedure	50
	Guide to Entering Service Mode and Factory Reset (PD100)	53
Chapter 5	Exploded Overview	54
	Exploded Overview	54
Appendix	Serial Number Definition System	80
	I. Serial Number System Definition	80
	II. PCBA Code Definition	81
	III. The Different Parts between PD100 and PD120	82

System Introduction

Technical Specification

Item	Description
Dimensions (WxHxD)	230 x 122.8 x 238 mm
Weight	Approx. 4.85 lbs (2.2 Kg)
Tilt Angle	7 degree with elevator mechanism
Keystone correction	+/-16 degree (32 degree) (Horizontal)
Lamp Door Projection	Lamp power supply shut off automatically when door open
Power Supply	Universal AC 100-240V ~ 50-60Hz with PFC input 200W for Philips UHP Lamp @ normal operation Variance FAN speed control (Depends on temperature variant)
Projection Lens	F#2.7~3.0, f=21.83mm~23.81mm, 1.10X Mechanical Zoom Lens
Throw Distance	1.5m - 10m (Optical Performance) 1.5m - 12m (Mechanical Travel)
Brightness	1700 ANSI Lumens (Typical; Full Power Mode) 1170 ANSI Lumens (Typical; Eco Mode) 1300 ANSI Lumens (Engineering Minimum; Full Power Mode)
Contrast	1000 : 1 Full White and Black (Minimum; Full Power Mode) 1800 : 1 Full White and Black (Typical; Full Power Mode)
Uniformity	65% Japan standard (Minimum; Full Power Mode) 80% Japan standard (Typical; Full Power Mode)
Temperature	Operating : 5~35°C Storage : -20~60°C
Maximum Humidity	Operating : -5~35°C, 80%RH (Max.), non-condensing Storage : -20~60°C, 80%RH (Max.), non-condensing
Acoustic noise level	38 dB(A) (Typical, Under 23 +/- 2°C; Full Power Mode without DVD/wireless) 30 dB(A) (Typical, Under 23 +/- 2°C; Eco Mode without DVD/wireless) Noise measurement follows ISO7779, A-weighted sound pressure level measurement, 7200 rpm color wheel rotational speed
Lamp Life	1500 hours min, 50% survival rate (Full Power Mode) 2000 hours min, 50% survival rate (Eco Mode)
Altitude	Operating : 0~2,500 ft for 5 °C~35°C 2,500~5,000 ft for 5 °C~30°C 5,000~10,000 ft for 5 °C~25°C Storage : 40,000 ft (Max.)
MTBF	Operating more than 12,000 hours (90% Confidence Level)

Product Overview

Main Unit



Item	Description
1	Focus Ring
2	Zoom Ring
3	Zoom Lens
4	Elevator Button
5	Elevator Foot
6	Remote Control Receiver
7	Connection Ports
8	Power Socket
9	Control Panel

Control Panel

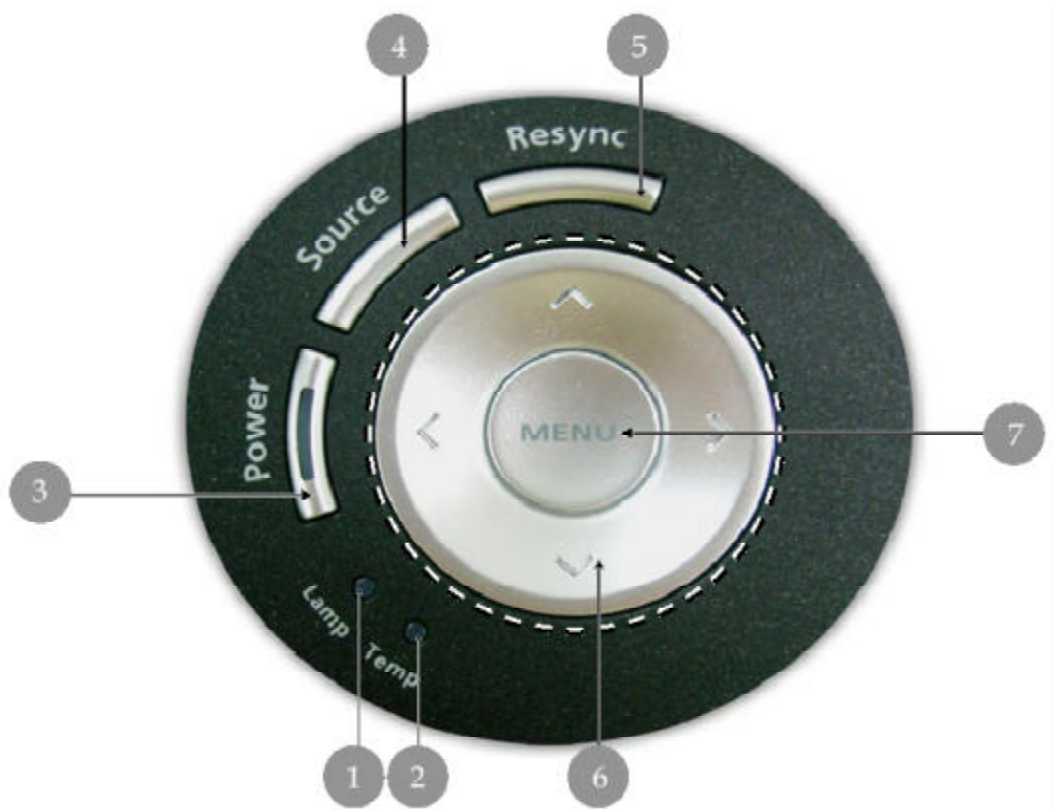

Item	Description
1	Lamp Indicator LED
2	Temp Indicator LED
3	Power / Standby and Indicator LED (Power LED)
4	Source
5	Resync
6	Four Directional Select Keys
7	Menu

Connection Ports

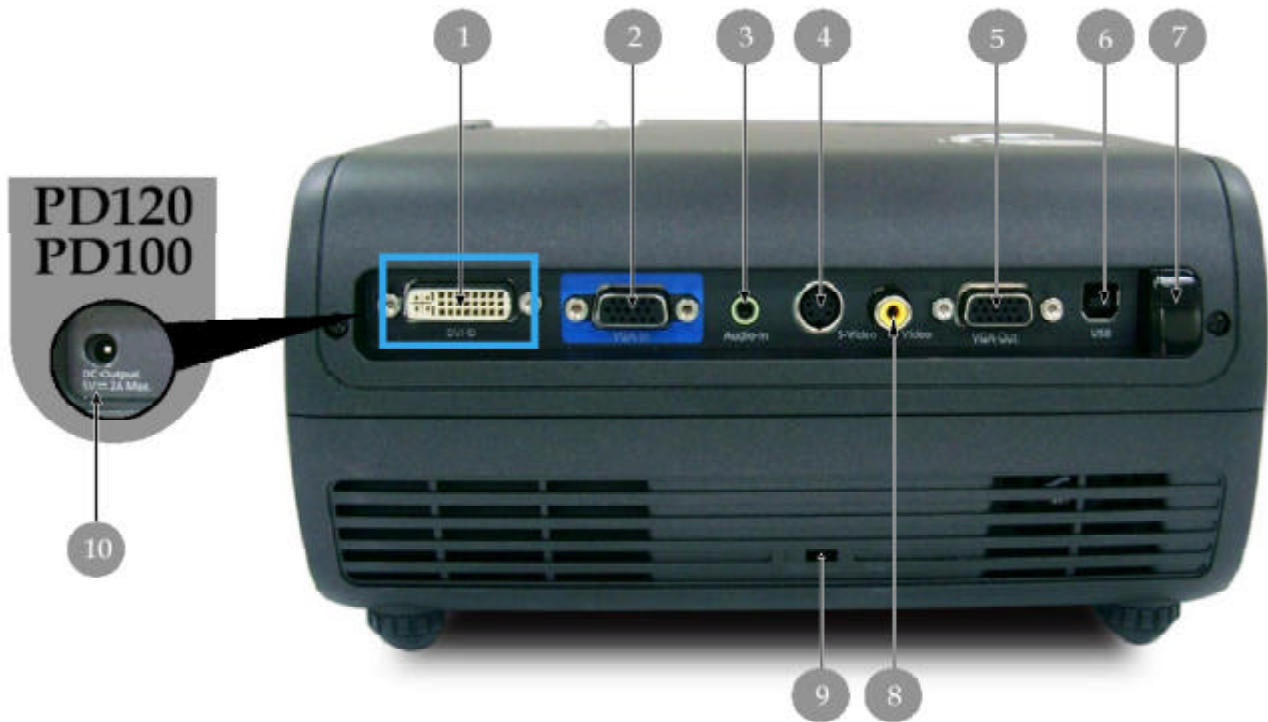

Item	Description
1	DVI Input Connector (for Digital signal with HDCP function) (Optional)
2	PC Analog Signal / HDTV / Component Video Input Connector
3	Audio Input Connector
4	S-Video Input Connector
5	Monitor Loop-through Output Connector
6	USB Connector
7	Remote Control IR Receiver
8	Composite Video Input Connector
9	Kensington™ Lock Port
10	5V DC Output Jack (dfor attached dongle device) (for PD100 only) (for PD120 only)

Connecting the Projector



Item	Description
1	Power Cord
2	VGA Cable
3	Composite Video Cable
4	USB Cable
5	VGA to Component / HDTV Adapter
6	S-Video Cable
7	Audio Cable Jack / Jack
8	DVI Cable (Optional Accessory)
9	5V DC Output Jack for attached Dongle Device (for PD100 only) (for PD120 only)

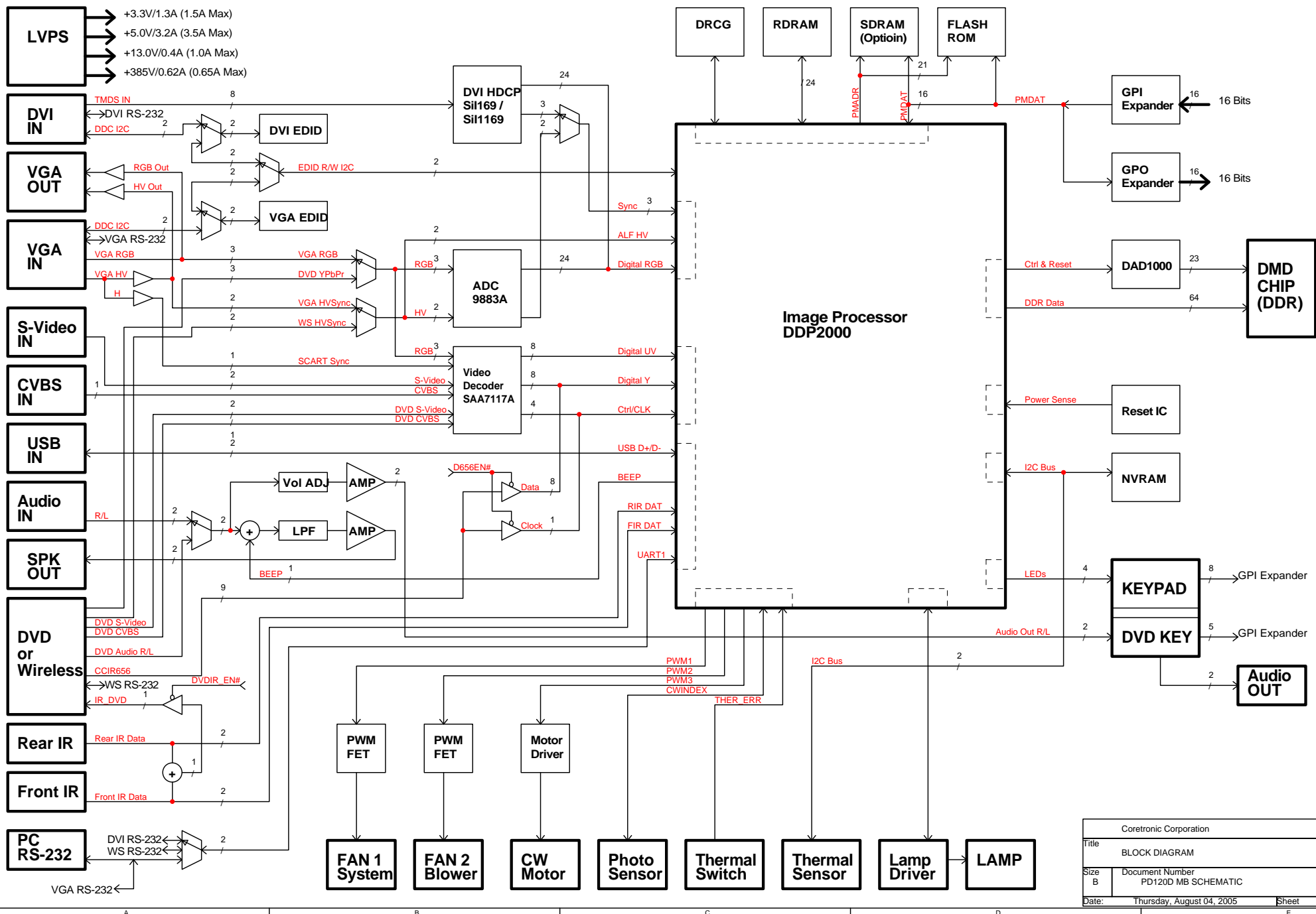

Coretronic Corporation		
Title	BLOCK DIAGRAM	
Size	Document Number	Rev
B	PD120D MB SCHEMATIC	D
Date:	Thursday, August 04, 2005	Sheet 1 of 19





Firmware Upgrade

Equipment Needed

Software : (DDP 2000- USB)

- DLP Composer
- Firmware (PD100 / PD120)

Hardware :

Item	Photo	Item	Photo
Projector (PD100)		Projector (PD120)	
Power Cord		PC or Laptop	
USB Cable			

Installation Procedure

DLP Composer Lite Setup Procedure

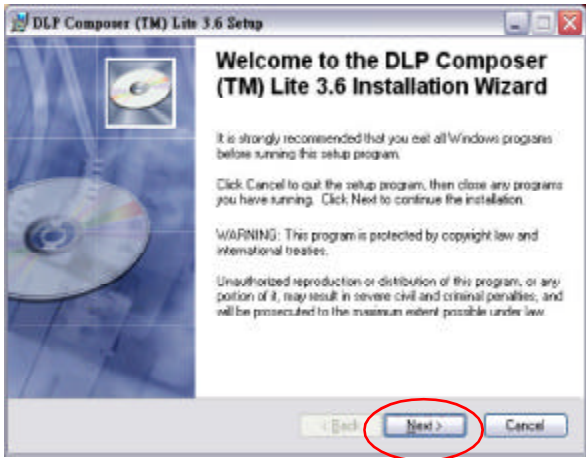
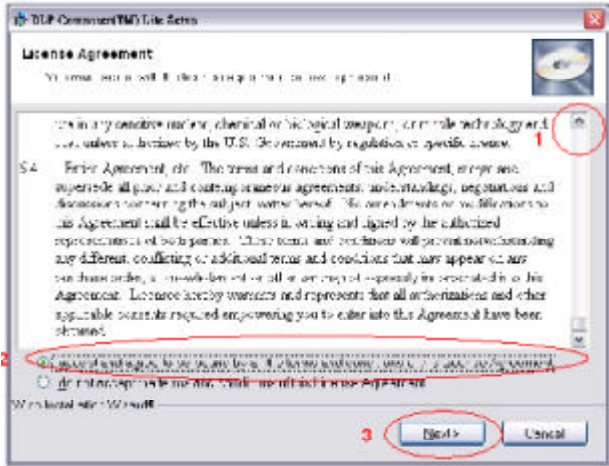
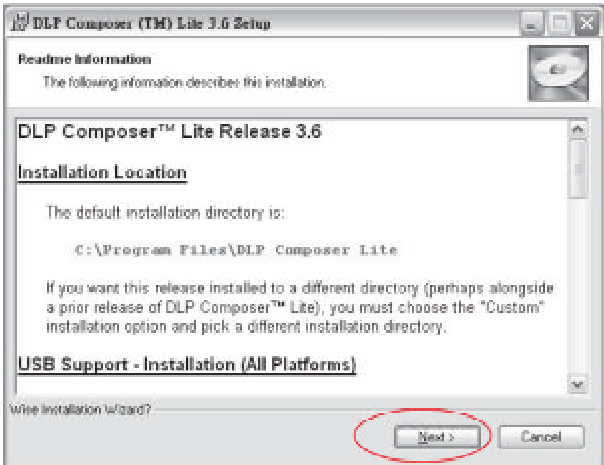
No	Step	Procedure	Photo
1	Execute FW program	Choose "DLP Composer Lite v3.6 Setup" program.	
2	Next	Click "Next" button.	
3	Next	<ol style="list-style-type: none"> 1. Reading the "License Agreement" rules. 2. Choose "I accept and agree to be bound by all the terms and conditions of this License Agreement" icon, 3. Click "Next" button. 	
4	Next	Click ""Next"" button.	

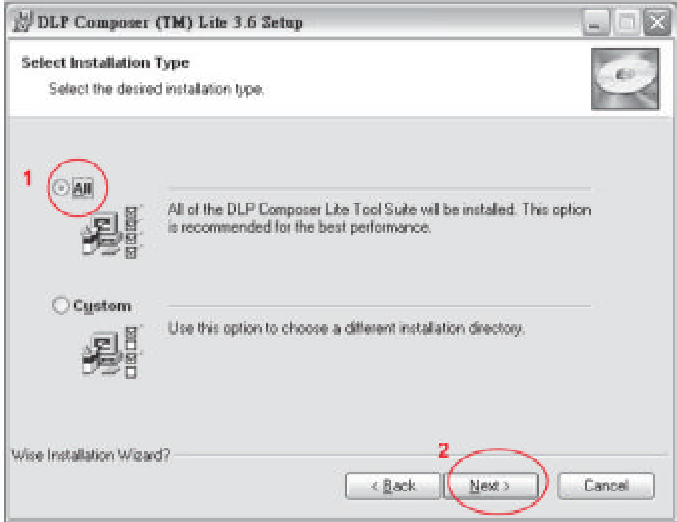
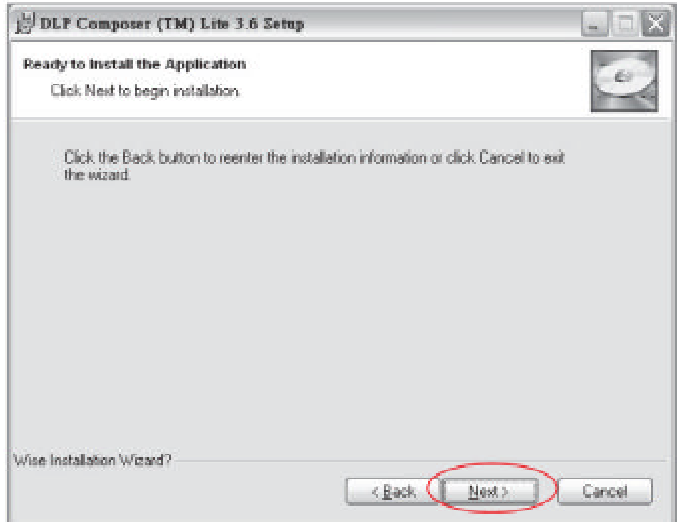
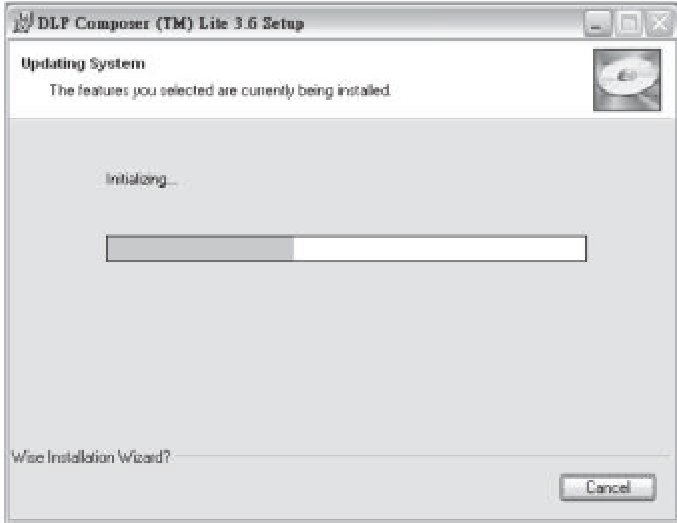
No	Step	Procedure	Photo
5	Next	1. Choose "All" icon 2. Click "Next" button.	 <p>The screenshot shows the 'Select Installation Type' dialog box. The 'All' radio button is selected and circled with a red '1'. The 'Next >' button is circled with a red '2'. The text reads: 'All of the DLP Composer Lite Tool Suite will be installed. This option is recommended for the best performance.' Below it, the 'Custom' option is unselected with the text: 'Use this option to choose a different installation directory.' At the bottom, there are three buttons: '< Back', 'Next >', and 'Cancel'.</p>
6	Next	Click "Next" button.	 <p>The screenshot shows the 'Ready to install the Application' dialog box. The text reads: 'Click Next to begin installation.' Below it, it says: 'Click the Back button to reenter the installation information or click Cancel to exit the wizard.' At the bottom, there are three buttons: '< Back', 'Next >', and 'Cancel'. The 'Next >' button is circled with a red oval.</p>
7	Processing	The program is executing "Initializing" status.	 <p>The screenshot shows the 'Updating System' dialog box. The text reads: 'The features you selected are currently being installed.' Below it, it says: 'Initializing...'. There is a progress bar that is partially filled. At the bottom right, there is a 'Cancel' button.</p>

USB Driver Upgrade Procedure

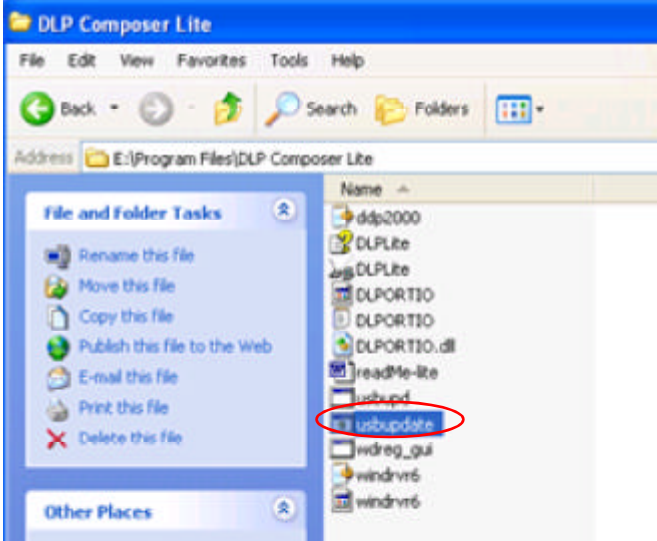
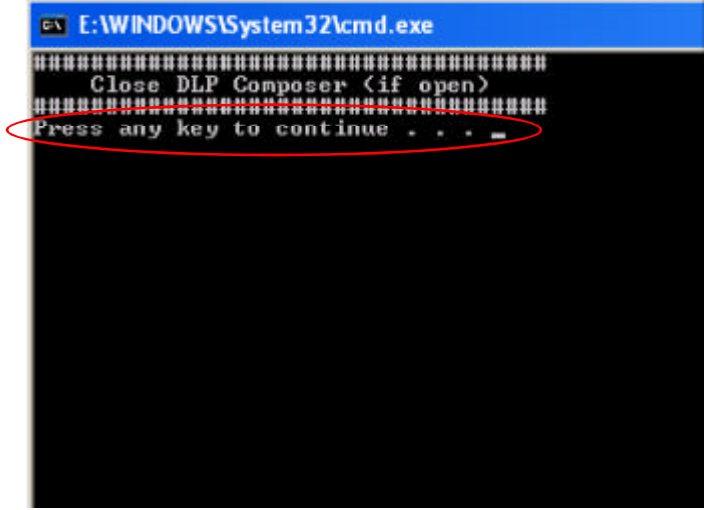
No	Step	Procedure	Photo
1	Set-up	1. Plug in USB Cable into the Projector. 2. Hold on "Menu" button and then plug in Power Cord. 3. Wait for about 5 seconds. (Note: The system fan will not function. The light will not function as well.)	
2	Execute Program	Execute the C:\Program files\DLP Composer\usbupdata.cmd. (Note: The "DLP Composer" program must be closed first.)	
3	Type any key to continue	Type any key to continue. Then, wait for about 1 minute.	

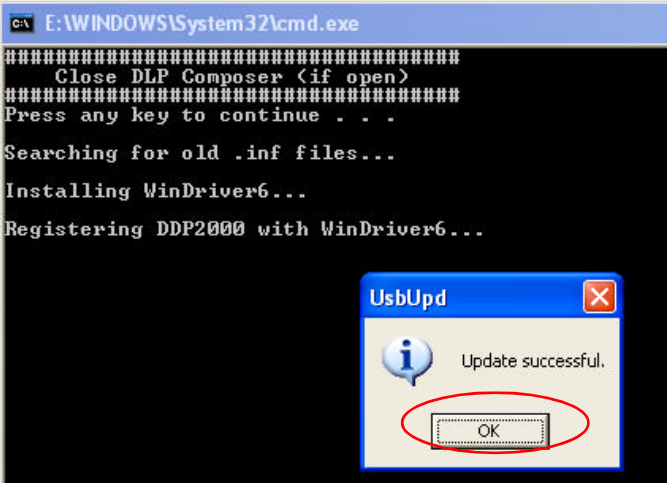
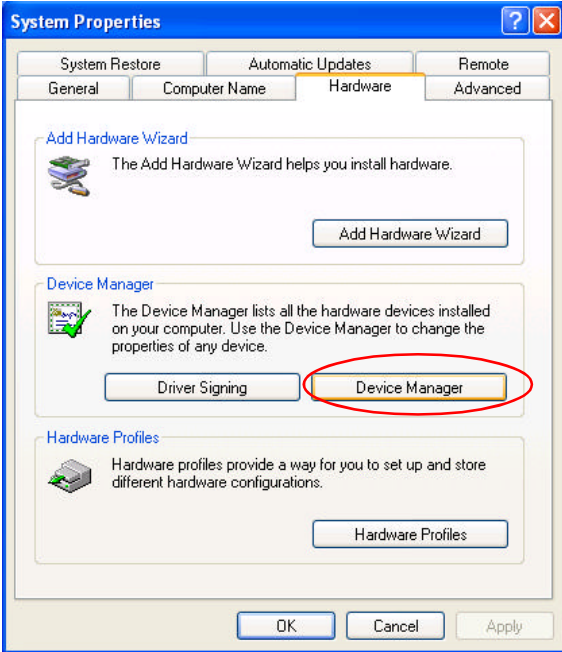
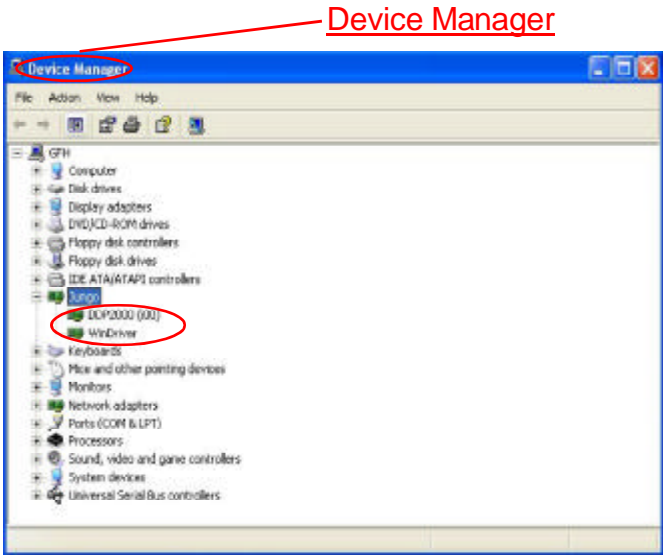
No	Step	Procedure	Photo
4	Update Successfully	Click "OK". The USB driver is updated successfully.	
5	Device Manager	<ol style="list-style-type: none"> Right click "My computer" on the desktop. Select "Properties" on the popup menu to launch the "System Properties" window. Choose "Hardware" and then click "Device Manager". 	
6	Ensure "DDP2000" & "WinDriver" are properly installed	Click "Jungo" to ensure "DDP2000" and "WinDriver" are properly installed. If not, repeat Step 1~5.	

Firmware Upgrade Procedure

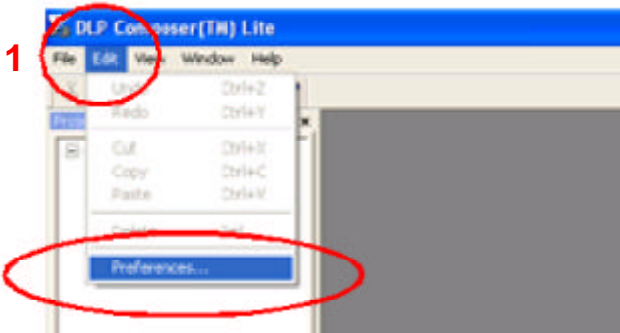
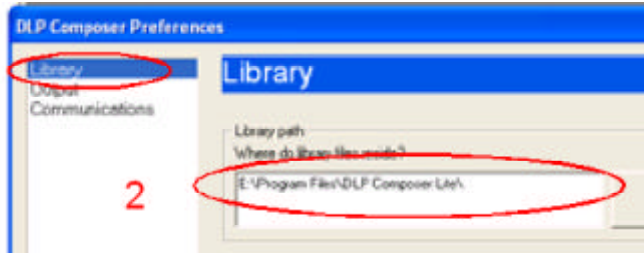
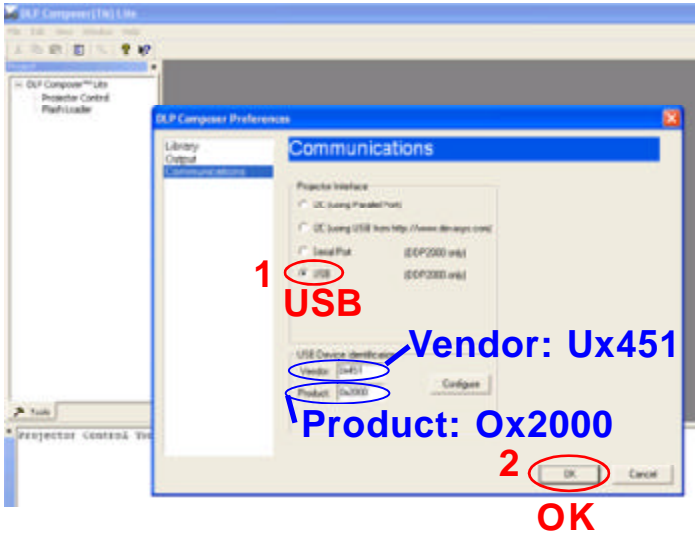
No	Step	Procedure	Photo
1	Set-up	Link PC COM1 and projector	
2		Execute the "DLP Compose™" file.	
3		Click "Edit" and "Preferences".	
4		1. Click "Library". 2. The library path located in the default installation directory is: C:\Program Files\DLP Composer. If not, press "Browse" to select the right path.	
5		1. Select "Edit\Preferences\ Communications" and choose "USB". 2. Click "OK".	

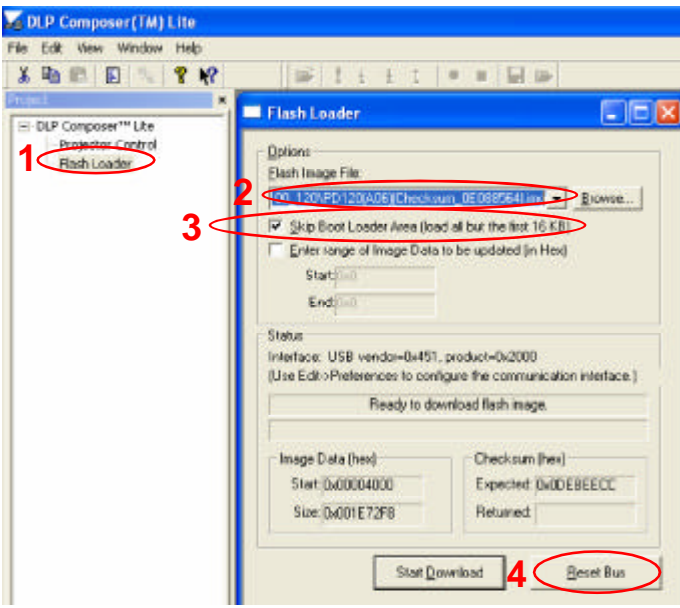
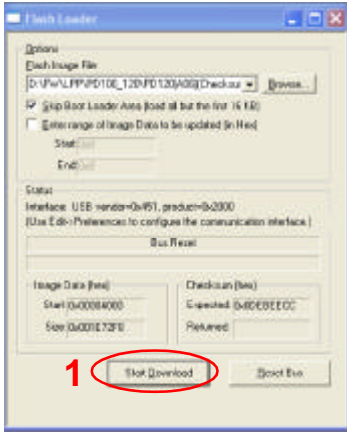
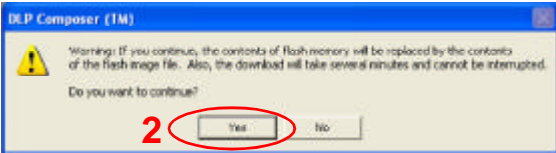
No	Step	Procedure	Photo
6		<ol style="list-style-type: none"> Choose "Flash Loader" Click "Browse" to search the firmware file. (PD100 / PD120) Select the item "Skip Boot Loader Area (load all but the first 16KB)." Click "Reset Bus" to erase the flash memory. <p>(Note: If the error message "cannot open USB driver - No projectors found" appears, please unplug the USB Cable and replug, then re-do 4. Click "Reset Bus" to erase the flash memory.)</p>	 <p>Note:</p>
7		<ol style="list-style-type: none"> If the firmware is ready, click "Start Download" to process the firmware upgrade. Click "Yes" to erase the flash memory. 	 

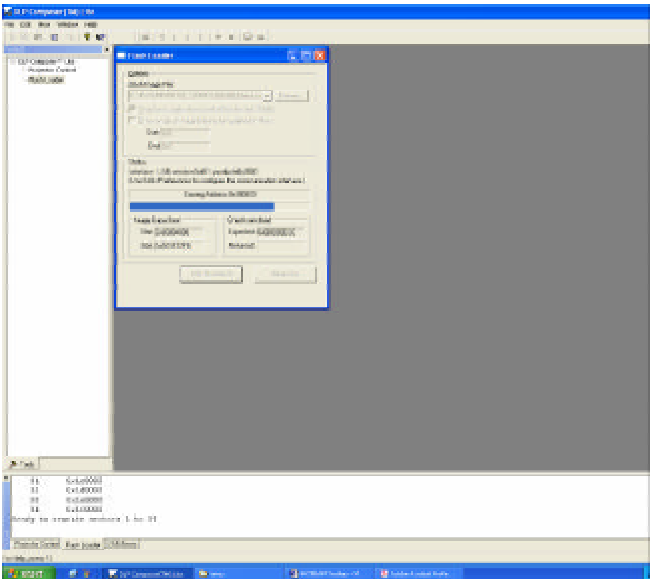
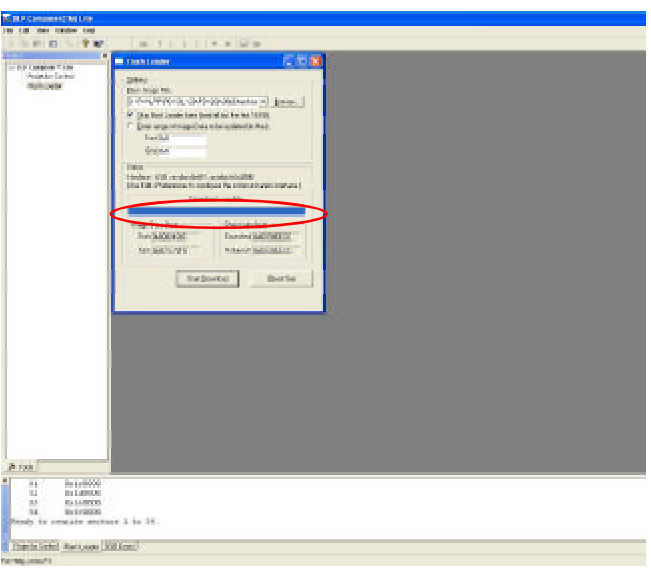
No	Step	Procedure	Photo
8	Proceeding	Proceeding Picture	
9		<p>1. When Firmware Upgrade Process is finished, the LED power</p> <p>2. Unplug USB Cable and Power Cord. Re-plug in Power Cable after 3 mins.</p>	
10	Check Firmware	<p>Restart the unit and enter the Service Mode to check the Firmware Version.</p> <p>(For entering Service Mode, please refer to Chapter 4 Function Test and Alignment Procedure.)</p>	

EDID Upgrade

Equipment Needed

Software:

- EDID Key-in Program
- EDID Program (Generic V0.51)
- EDID Table (*.ini)

Hardware:

- V3 Fixture for EDID Key-in
(Fixture: JP3 must be closed)

Item	Photo	Item	Photo
RS-232 Cable (F - M)		Power Adapter for Fixture	
DVI Cable		Generic Fixture	
VGA Cable		Power Cord	
PC		One additional monitor (for checking the program execution)	
Projector (PD100)		Projector (PD120)	

Setup Procedure

No	Step	Procedure	Photo
1	Connect All Ports	1. Power Adapter to Fixture JP1 2. Fixture P1 to PC COM1 Port 3. Fixture P2 to Projector Analog Port 4. Fixture P3 to Projector Digital Port	
2.	Power On Fixture	Power on Fixture	

EDID Key-In Procedure

No	Step	Procedure	Photo
1	Execute EDID Program.	Click on "EDID" to execute EDID Program.	
2	Choose Model	1. In the Port Selection Bar, please choose the Port that you use. Ex: If you use "COM 1", choose COM 1 in the Port selection. 2. Click on "Model". 3. Choose the EDID that responds to the model that you choose.	



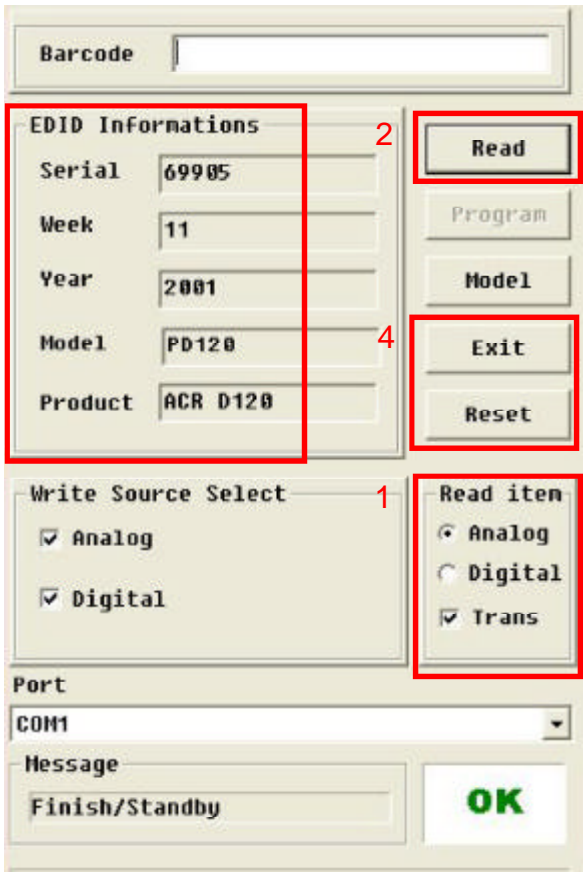
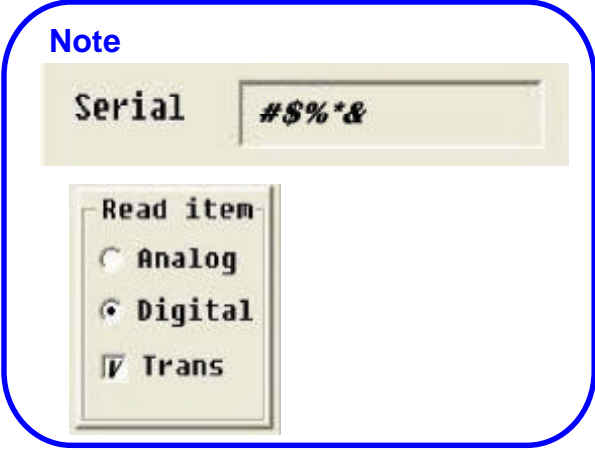



No	Step	Procedure	Photo
3	Key in Serial Number	1. Key in the Serial Number into the Barcode blank space. 2. In "White Source Select", make a check in "VGA" and "DVI". 3. Check the COM Port is "COM 1". 4. Click "Program".	
4	Change Cable to Analog	"Please change the Cable to Analog" message is shown on the screen, then click "OK". <i>Note: "RUN" message will appear on the screen.</i>	
5	Change Cable to Digital	"Please change the Cable to Digital" message is shown on the screen, then click "OK". <i>Note: "RUN" message will appear on the screen.</i>	
6	Finished	When the EDID program is completed, the message, "OK", will appear on the screen.	

No	Step	Procedure	Photo
7	Check the whole process	<p>1. In the "Read Item" Selections, choose the Port that you use. Ex: If you use the Analog Port, choose "Analog" in the "Read Item".</p> <p><i>Note: If the code in the Serial Blank is scrambled, please make a check in "Trans".</i></p> <p>2. Click on "Read" to read EDID information.</p> <p>3. The "EDID Informations" will show the result.</p> <p>4. Click "Reset" to do the next unit or "Exit" to close the EDID program.</p>	 <p>Note</p> 

Mechanical Disassembly & Reassembly

This section provides disassembly & Reassembly procedures for PD100 Micro Portable SVGA DMD Projector. Before you begin any of these procedures, be sure to turn off the power, computer system, and other attached devices; then disconnect the power cable from the electrical outlet. Moreover, when you disassemble the projector, be sure to put the screws in a safe place and separate them according to their category.

Equipment Needed

Item	Photo	Item	Photo
Philips (+) : 107		Philips (+) : 102	
Screw Bit		Hex Screw : 5mm	
Tweezers		Screw Bit	

General Information

Before You Begin

Before proceeding with the disassembly procedure, make sure that you do the following procedures:

1. Turn off the power of the system and all the peripherals.
2. Unplug the AC adapter and all power and signal cables from the system.
3. Anti-static wrist strap.

Mechanical Disassembly Procedure

1. Remove Lamp Module

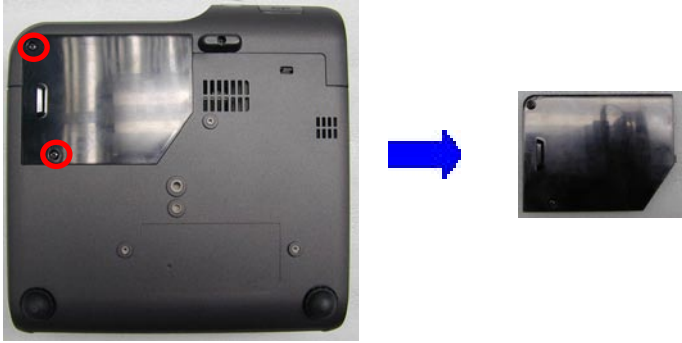
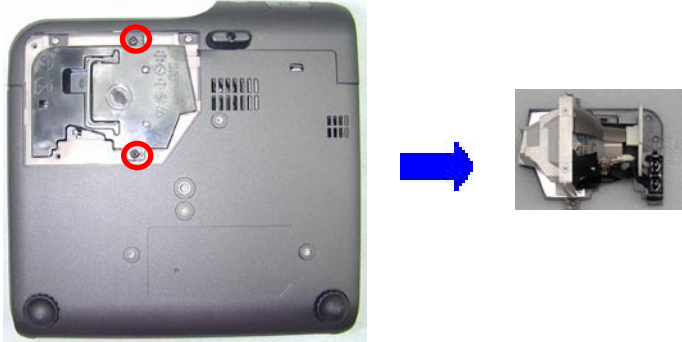
No	Procedure	Photo
1	Unscrew 2 screws to remove the Lamp Cover.	
2	Unscrew 2 screws to remove the Lamp Module.	

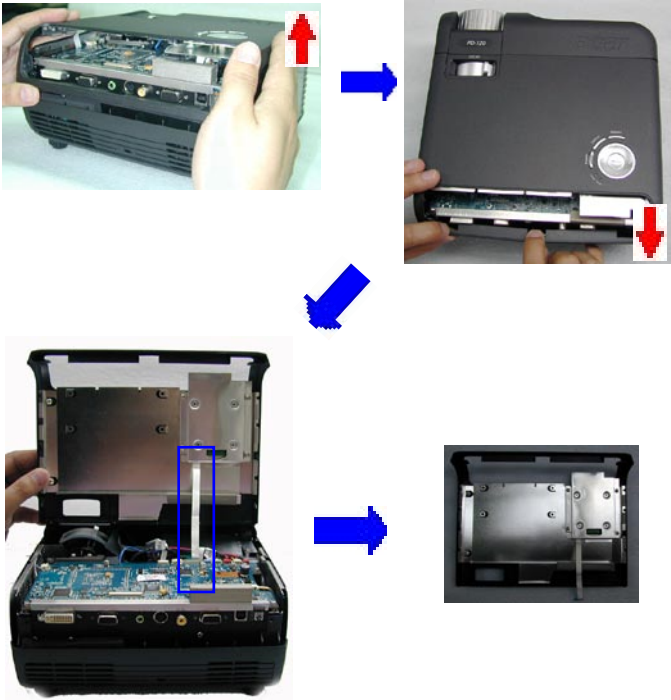

2. Remove IO Cover / Top Cover

No	Procedure	Photo
1	<p>Unscrew 2 screws & 6 hex screws to remove the IO Cover.</p>	
2	<p>1. Lift up the Top Cover first and then pull the Bottom Cover for easily separating the Top Cover.</p> <p>2. Remove 1 FPC Cable to remove the Top Cover.</p>	

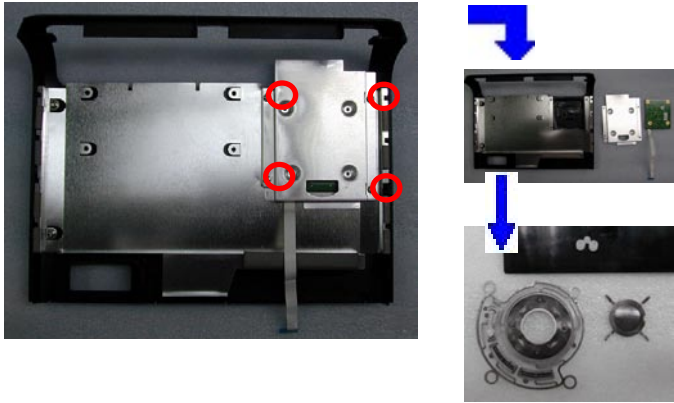
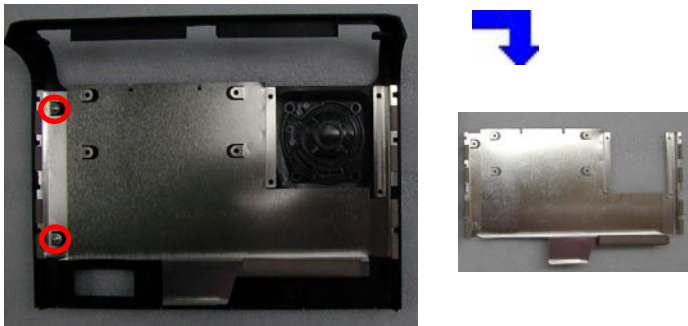
3. Remove Keypad Board

No	Procedure	Photo
1	1. Unscrew 4 screws to remove the Keypad Board. 2. Separate the Keypad Module.	
2	Unscrew 2 screws to remove the Top Cover Shielding.	

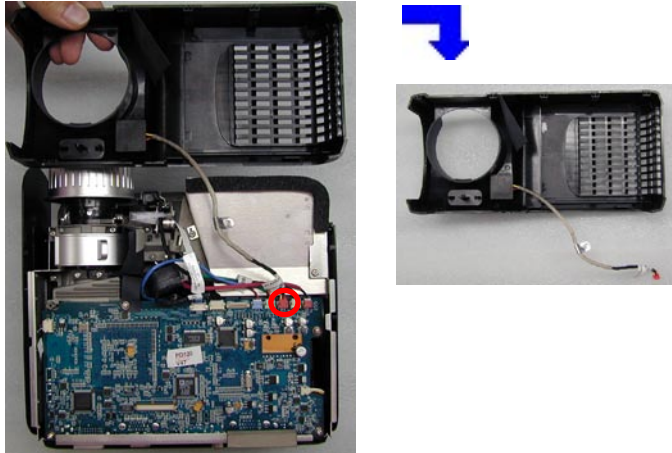
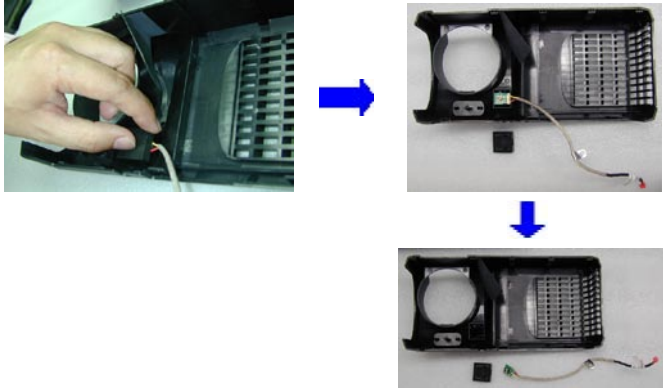
4. Remove Front Cover / IR Sensor Board / Elevator Push Button

No	Procedure	Photo
1	<p>1. Unscrew 1 screw to remove the IR Receiver.</p> <p>2. Unscrew 2 screws to remove the Front Cover.</p>	
2	<p>Unplug 1 connector (red color) to remove the Front Cover Module.</p>	
3	<p>Remove the Front IR Cover directly, and loosen 2 tenons to remove the IR Receiver Board.</p>	
4	<p>Loosen 2 tenons to remove the Elevator Push Button directly.</p>	

5. Remove Bottom Cover Module

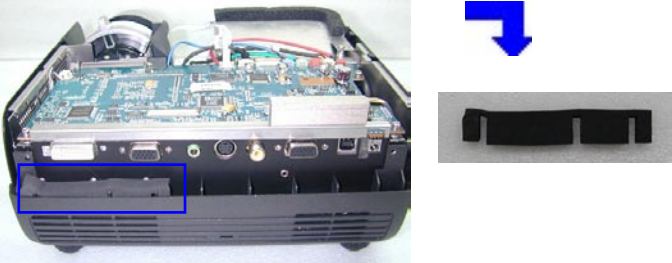
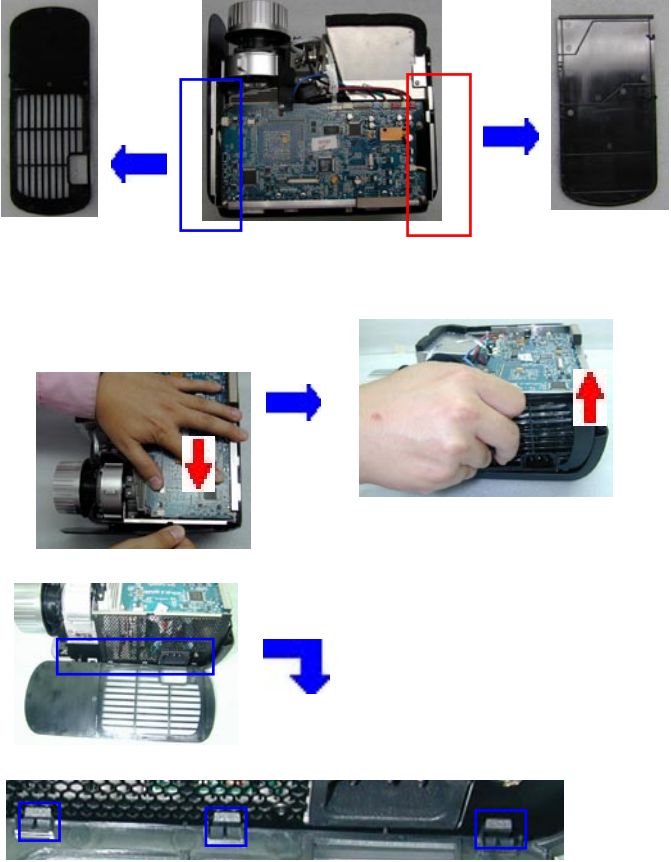
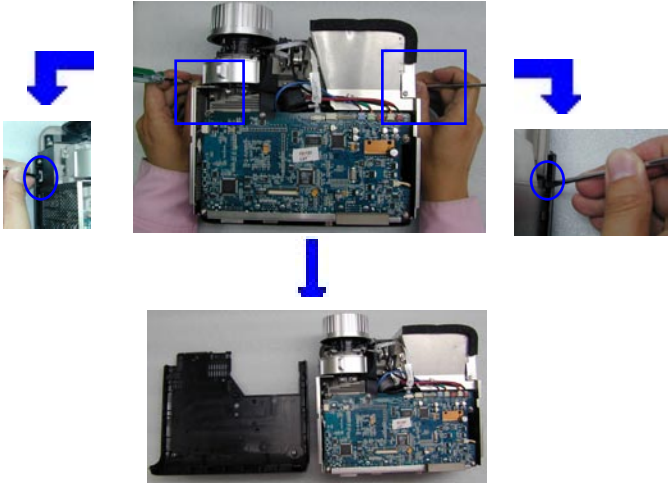
No	Procedure	Photo
1	Remove Bottom Cover Sponge.	
2	Remove Side Covers. (Right Cover & Left Cover) Note 1: When disassembling the Side Cover, push the side cover outside forwards and then pull it up directly. Note 2: When reassembling the Side Cover, please locate & align the tenons as the picture shows.	
3	Unplug 2 tenons in the shieldings to separate the Bottom Cover Module with the unit.	

6. Remove Main Board

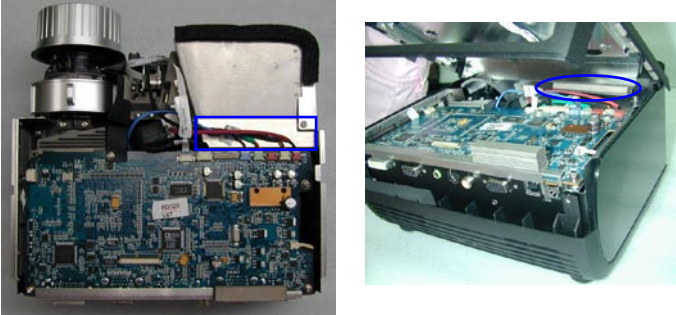
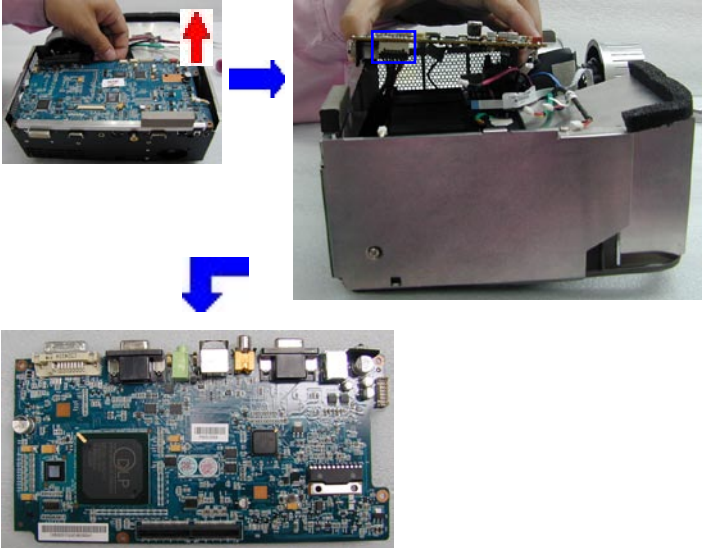
No	Procedure	Photo
1	<p>Unplug 8 connectors first and then unscrew 4 screws.</p> <p>Note: When Reassembling the Main Board with the Top Cover, please be aware of the wire arrangement. The wire arrangement should go as the picture shows (not exceeding 1/2 of the red blank space) to best allocate the Top Cover Sponge.</p>	 <p>The main board is shown with 8 connectors highlighted by blue boxes and 4 screws highlighted by red circles. A label 'PD120 V47' is visible on the board.</p>  <p>Two smaller images show the wire arrangement. The left one shows a blue box around the wires, and the right one shows a blue circle around the wires in the chassis, indicating they should not exceed half the red blank space.</p>
2	<p>1. Lift up the front part of Main Board first; then, take off the Main Board.</p> <p>2. Unplug 1 connector to remove the Main Board.</p>	 <p>A sequence of three images showing the removal process. The top-left image shows a hand lifting the front of the board, with a red arrow pointing up. The top-right image shows the board being lifted out of the chassis, with a blue arrow pointing right. The bottom image shows the removed main board, with a blue arrow pointing down from the top-right image.</p>

7. Remove EMI Shielding / Speaker

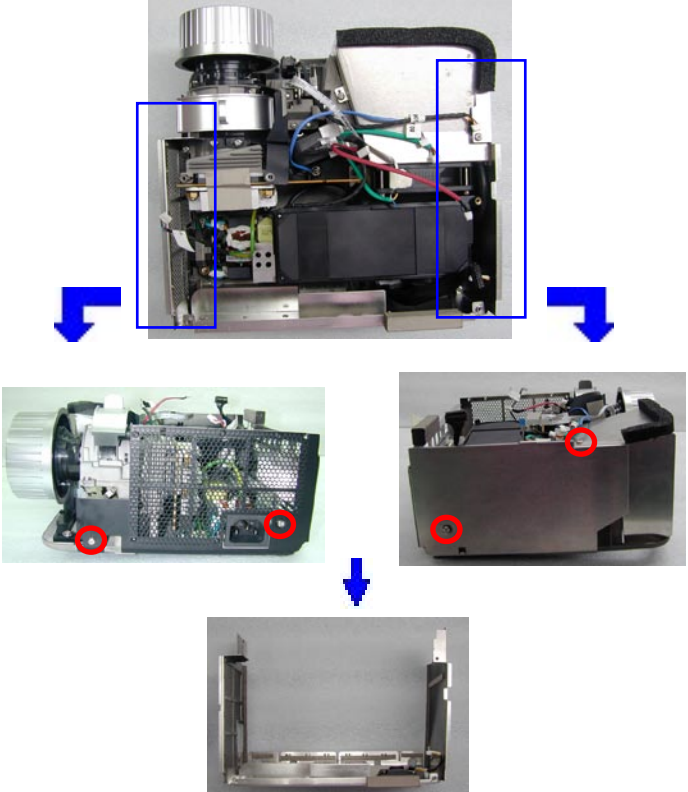
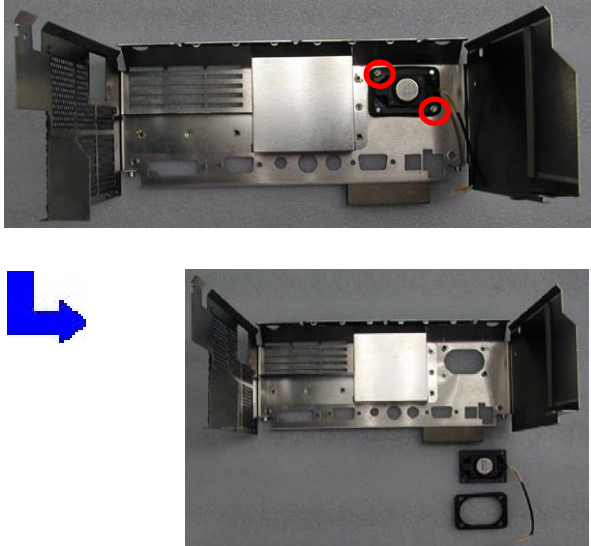
No	Procedure	Photo
1	<p>Unscrew 4 screws to remove the EMI Shielding Cover of units.</p>	
2	<p>Unscrew 2 screws to remove the Speaker.</p> <p>Note: The Speaker isn't designed with error-proof. Please be aware of wire-arrangement as the picture shows.</p>	

8. Remove Axial Fan Module

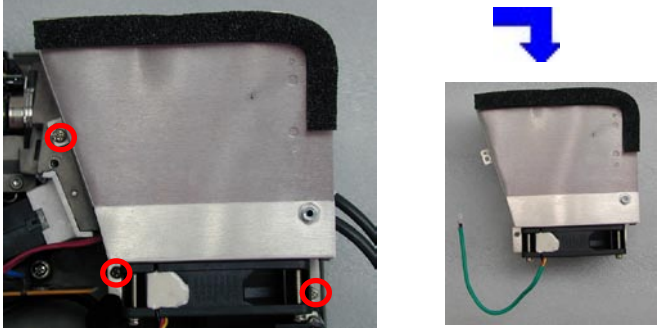
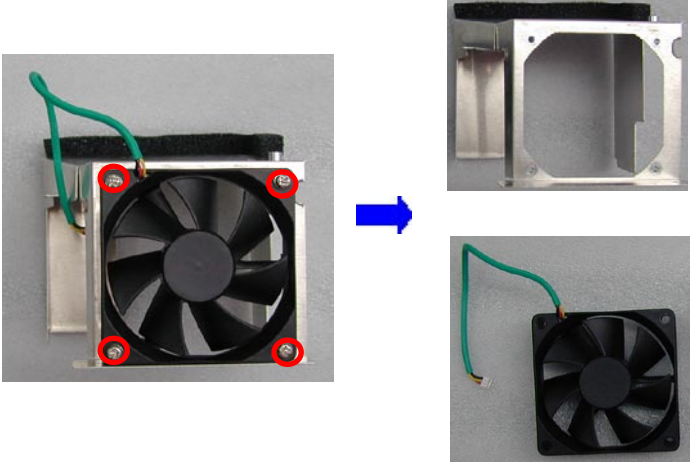
No	Procedure	Photo
1	Unscrew 3 screws to remove Axial Fan Module.	
2	Unscrew 4 screws to remove the System Fan. Note: The System Fan isn't designed with error-proof. Please be aware of the wire-arrangement.	

9. Remove Lamp Driver

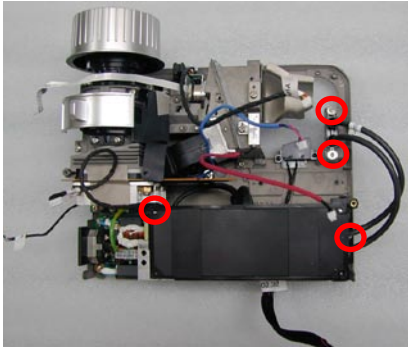
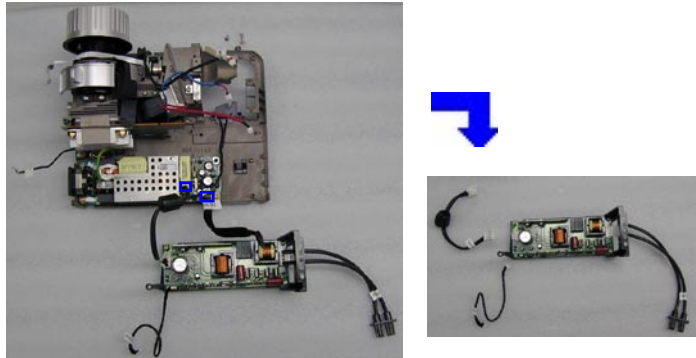
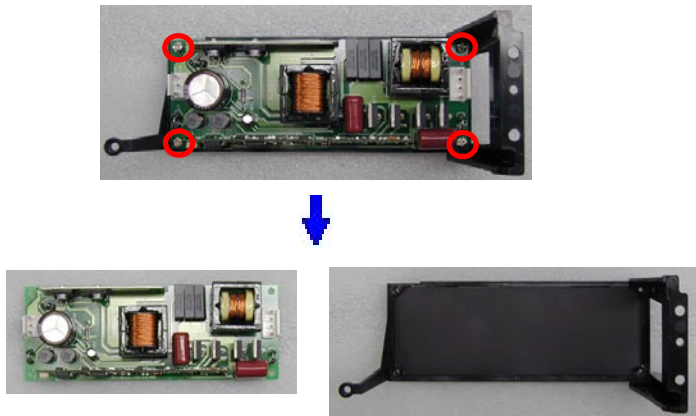
No	Procedure	Photo
1	Unscrew 4 screws.	
2	Unplug 2 connectors to remove the Lamp Driver Module. Note: When assembling the LVPS, please be aware of the LVPS connector connection. (the shorter wire should be connected to the LVPS, and the longer wire should be connected to the Lamp Driver.)	
3	Unscrew 4 screws to separate the Lamp Driver Housing.	

10. Remove LVPS / Interlock Switch / Thermal Switch

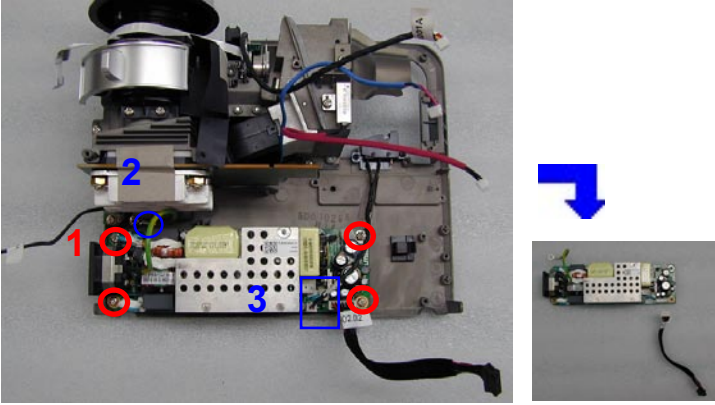
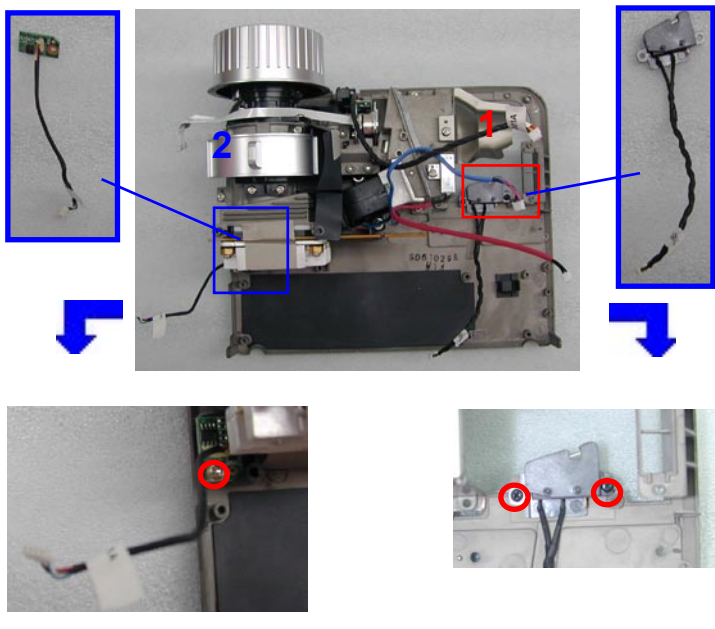
No	Procedure	Photo
1	<ol style="list-style-type: none"> 1. Unscrew 4 screws 2. Unscrew 1 screw in the grounding wire. 3. Unplug 1 connector in the Interlock Switch to remove the LVPS. 	
2	<ol style="list-style-type: none"> 1. Unscrew 2 screws to remove the Interlock Switch. 2. Unscrew 1 screw to remove the Assy Thermal Switch Board. 	

11. Remove Engine Module

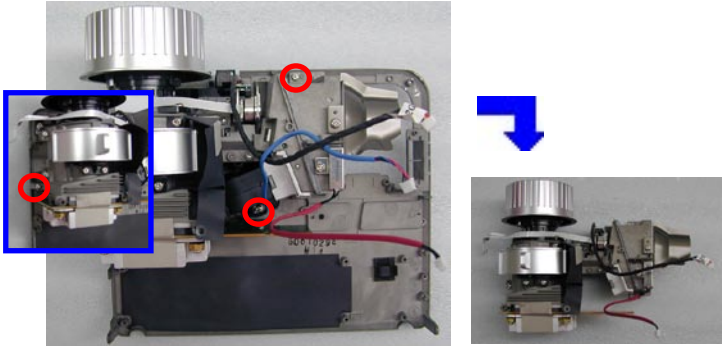
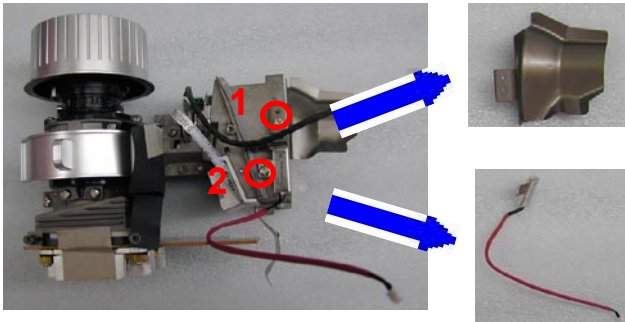
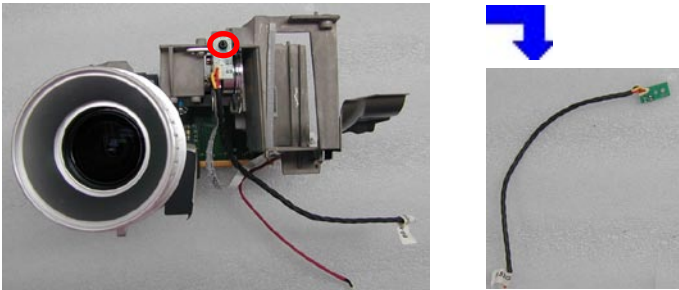
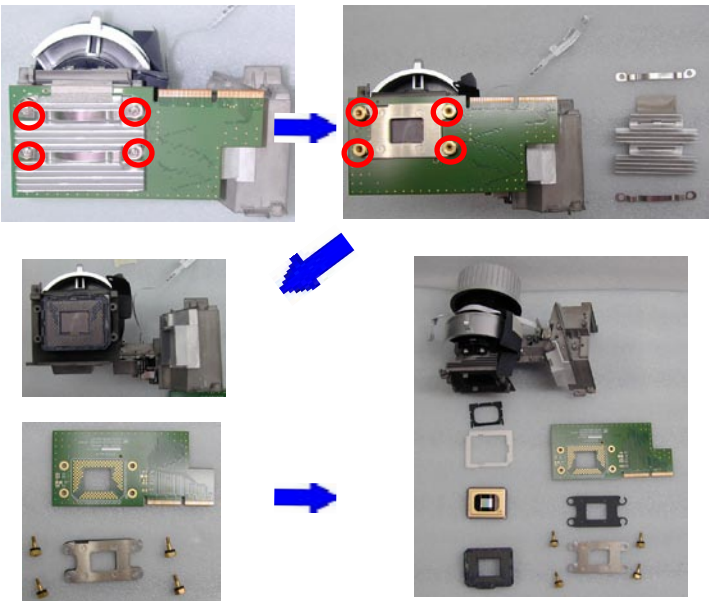
No	Procedure	Photo
1	Unscrew 3 screws to remove the Engine Module.	
2	1. Unscrew 1 screw to remove the Light Cut. 2. Unscrew 1 screw to remove the Thermal Sensor.	
3	Unscrew 1 screw to remove Photo Sensor Board.	
4	1. Unscrew 4 screws and tear off 1 EMI tape to remove the Heatsink. 2. Unscrew 4 big hex screws to remove the DMD Board. 3. Separate the DMD Board.	

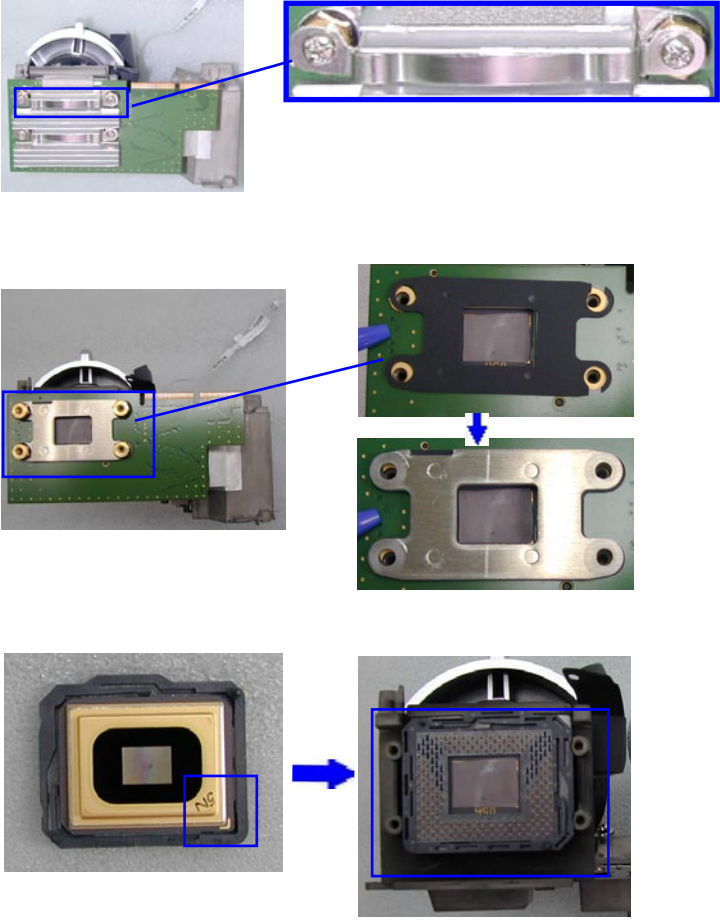
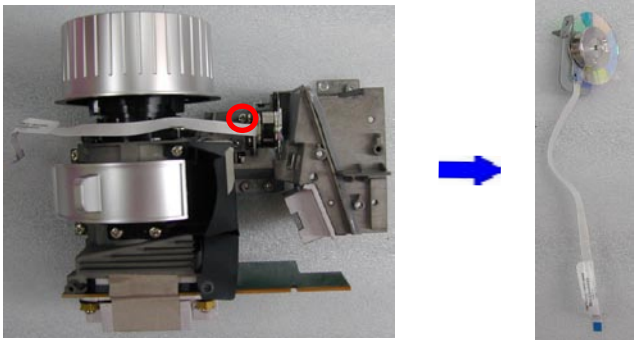
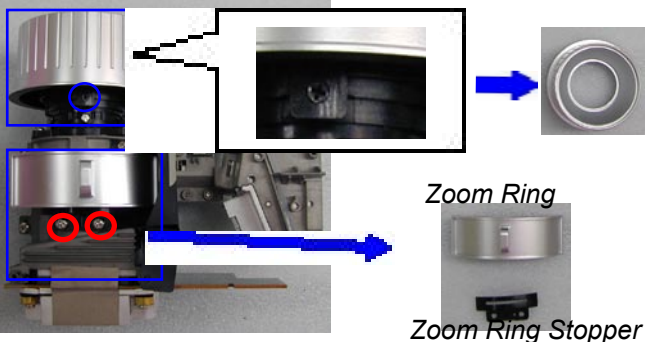
No	Procedure	Photo
	<p>When reassembling the DMD Module, please be aware of the following Notes.</p> <p>Note 1: The DMD Heasink Spring Plate should be placed as the picture shows.</p> <p>Note 2: The DMD Insulator Mylar & DMD Heatsink Backer Plate should be placed as the picture shows.</p> <p>Note 3: The DMD Chip should be reassembled as the picture shows.</p>	
5	<p>Unscrew 1 screw to remove the Color Wheel.</p>	
6	<p>1. Unscrew 2 screws to remove the Zoom Ring & Stopper. 2. Unscrew 3 screws to remove the Focus Ring.</p>	 <p style="text-align: right;">Zoom Ring Zoom Ring Stopper</p>

12. Remove Elevator / Blower Fan

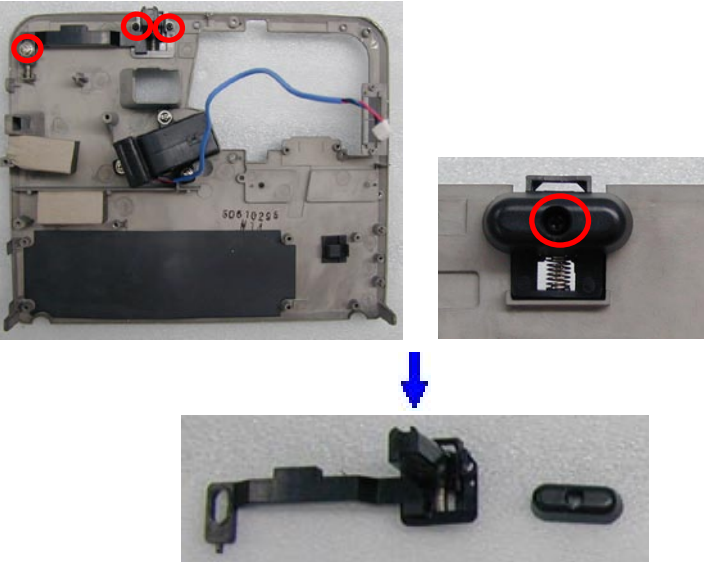
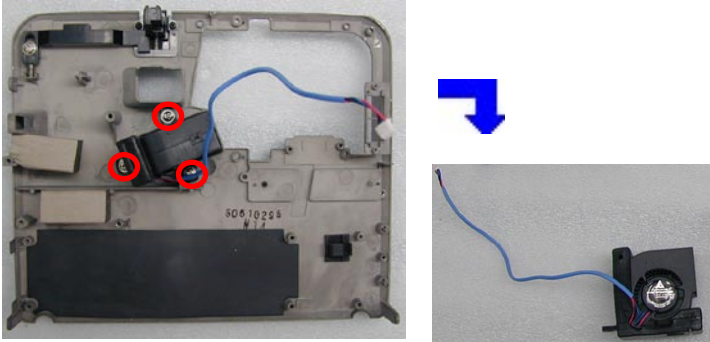
No	Procedure	Photo
1	Unscrew 4 screws to remove the Elevator.	
2	Unscrew 3 screws to remove the Blower Fan.	

Mechanical Reassembly Procedure

1. Assemble Elevator / Blower Fan

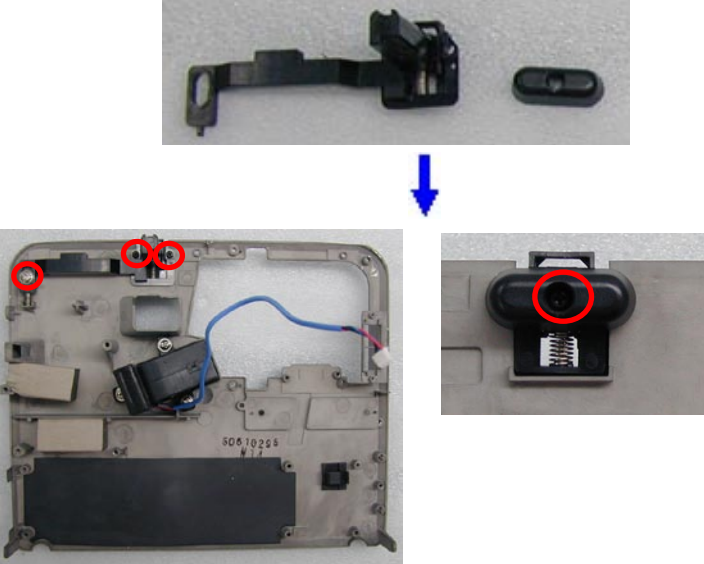
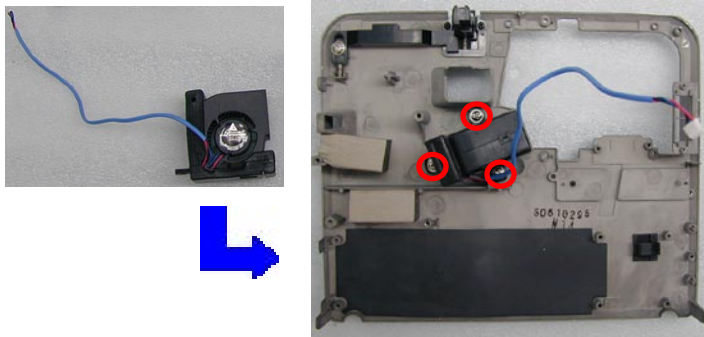
No	Procedure	Photo
1	Screw 4 screws to assemble the Elevator.	 <p>The photo for step 1 shows the assembly of the elevator. At the top, a black plastic component (the elevator) and a small black oval piece are shown. A blue arrow points down to a larger photo of the device's internal chassis. In this photo, four screws are circled in red, indicating where they should be installed. To the right, a close-up photo shows the black oval piece being inserted into the elevator component, with a red circle highlighting the insertion point.</p>
2	Screw 3 screws to assemble the Blower Fan.	 <p>The photo for step 2 shows the assembly of the blower fan. On the left, a blower fan with a blue wire is shown. A blue arrow points down and to the right to a larger photo of the device's internal chassis. In this photo, three screws are circled in red, indicating where they should be installed to secure the fan.</p>

2. Assemble Engine Module

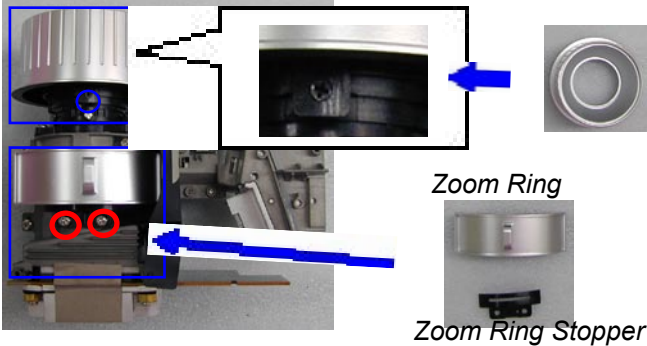
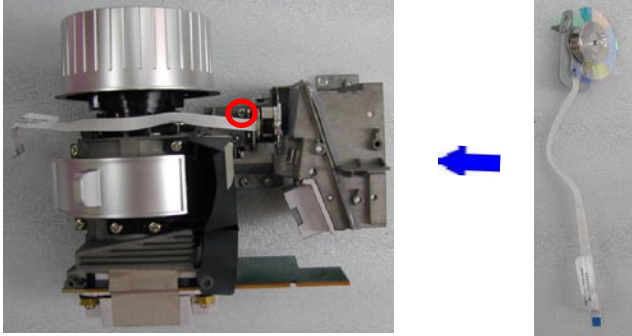
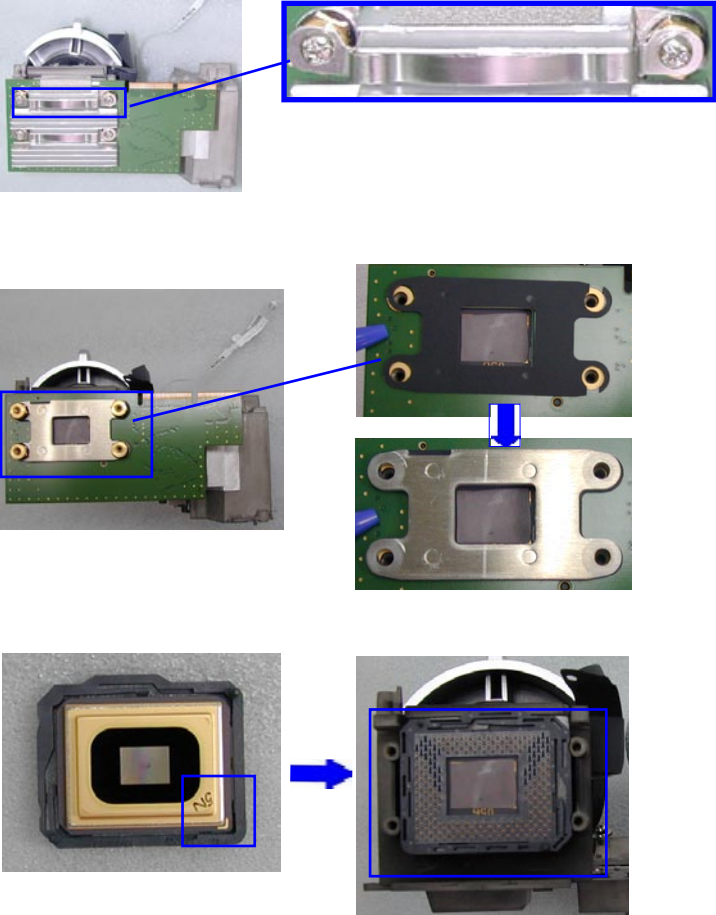
No	Procedure	Photo
1	<p>1. Screw 2 screws to assemble the Zoom Ring & Stopper.</p> <p>2. Screw 3 screws to assemble the Focus Ring.</p>	 <p>Zoom Ring</p> <p>Zoom Ring Stopper</p>
2	<p>Screw 1 screw to assemble the Color Wheel.</p>	
3	<p>When reassembling the DMD Module, please be aware of the following Notes.</p> <p>Note 1: The DMD Heatsink Spring Plate should be placed as the picture shows.</p> <p>Note 2: The DMD Insulator Mylar & DMD Heatsink Backer Plate should be placed as the picture shows.</p> <p>Note 3: The DMD Chip should be reassembled as the picture shows.</p>	

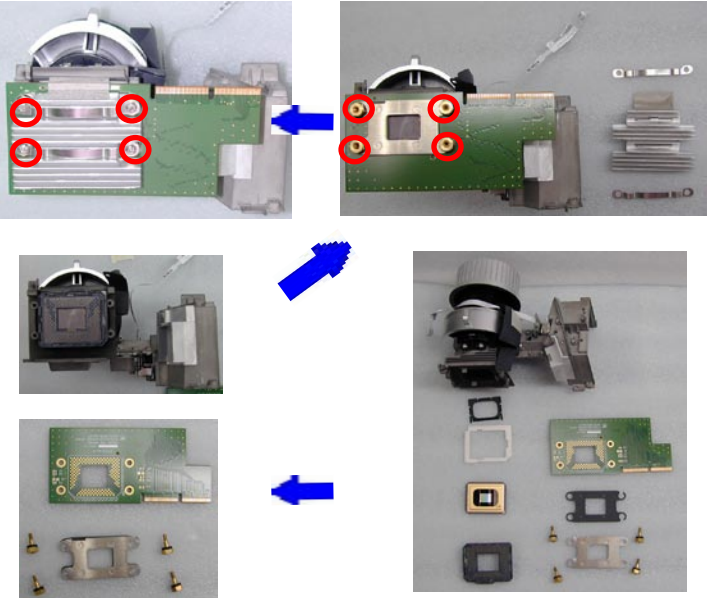
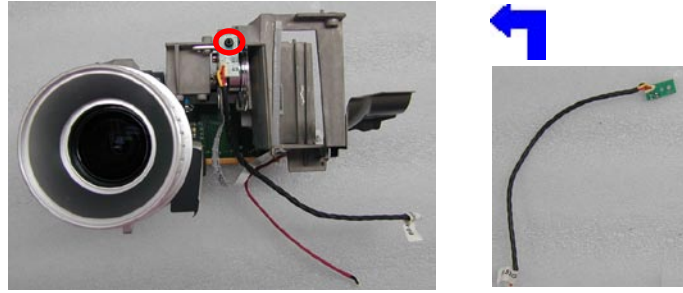
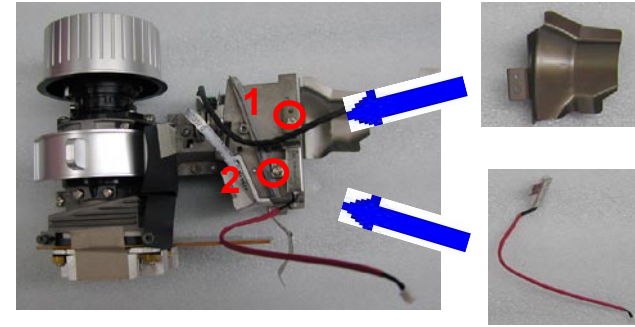
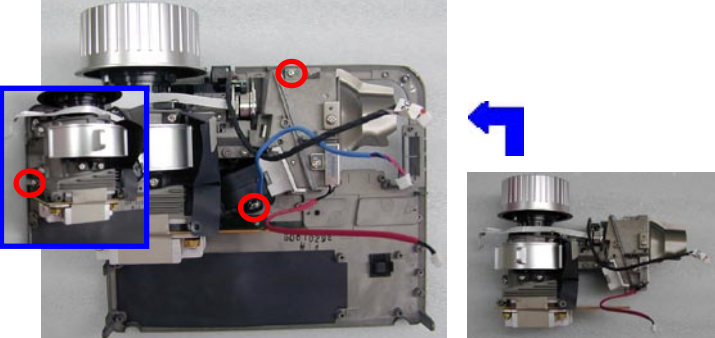
No	Procedure	Photo
	<p>1. Assemble the DMD Board Components.</p> <p>2. Screw 4 big hex screws to assemble the DMD Board.</p> <p>3. Screw 4 screws and put on 1 EMI tape to assemble the Heatsink.</p>	
4	Screw 1 screw to assemble the Photo Sensor Board.	
5	<p>1. Screw 1 screw to assemble the Light Cut.</p> <p>2. Screw 1 screw to assemble the Thermal Sensor.</p>	
6	Assemble 3 screws to assemble the Engine Module.	

3. Assemble Interlock Switch / Thermal Switch / LVPS

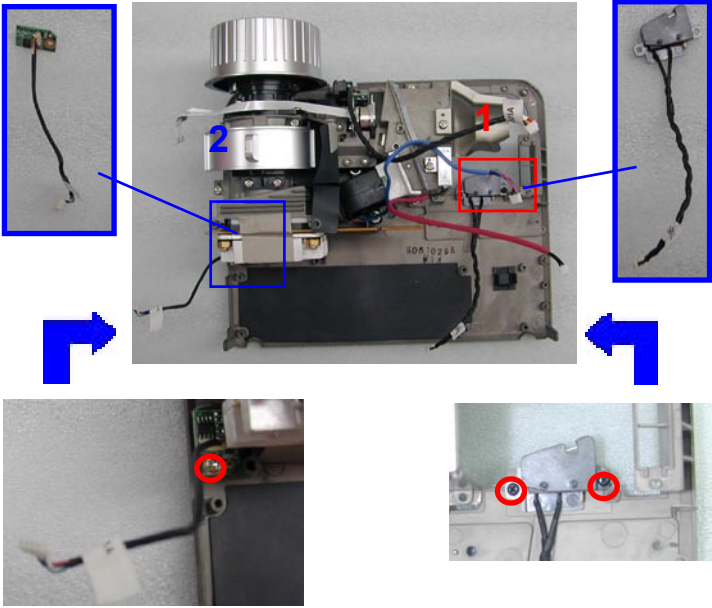
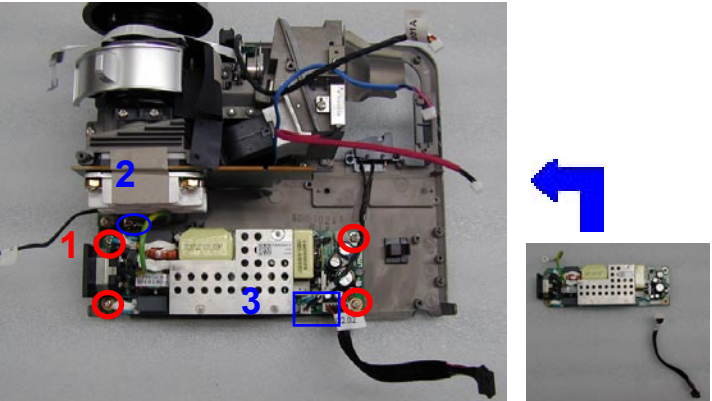
No	Procedure	Photo
1	<p>1. Screw 2 screws to assemble the Interlock Switch.</p> <p>2. Screw 1 screw to assemble the Assy Thermal Switch Board.</p>	 <p>The main photo shows the chassis with the interlock switch (labeled 2) and thermal switch board (labeled 1) being installed. Callout boxes show the interlock switch and thermal switch board separately. Red circles and arrows indicate the locations where screws are to be installed. Blue arrows point to the callout boxes.</p>
2	<p>1. Screw 4 screws</p> <p>2. Screw 1 screw in the grounding wire.</p> <p>3. Plug 1 connector in the Interlock Switch to assemble the LVPS.</p>	 <p>The main photo shows the LVPS (labeled 3) being installed on the chassis. Callout boxes show the LVPS separately. Red circles and arrows indicate the locations where screws are to be installed. Blue arrows point to the callout boxes.</p>

4. Assemble Lamp Driver

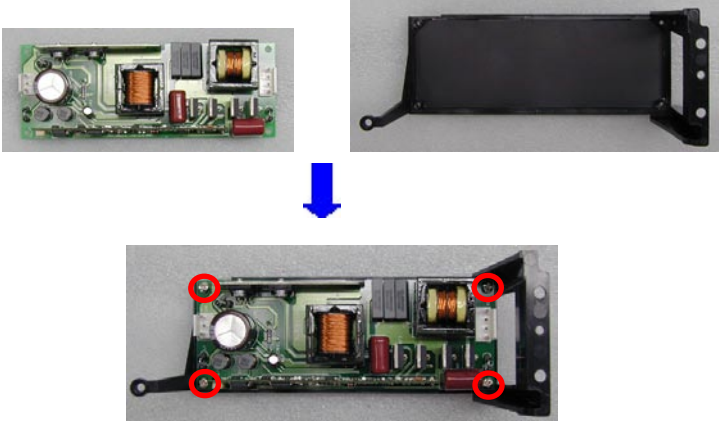
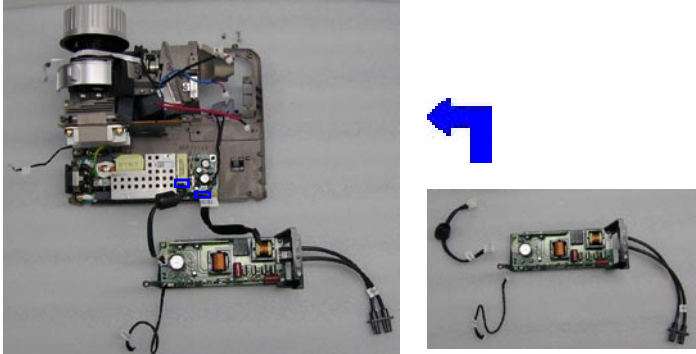
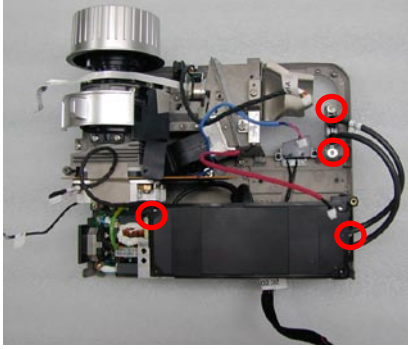
No	Procedure	Photo
1	Screw 4 screws to assemble the Lamp Driver Housing.	 <p>The photo shows the assembly of the lamp driver housing. At the top left, a green printed circuit board (PCB) with various electronic components is shown. To its right is a black plastic housing with four pre-drilled screw holes. A blue arrow points downwards to a third image where the PCB is mounted inside the housing. Four red circles are drawn around the screws that are being inserted into the housing to secure the PCB.</p>
2	Plug in 2 connectors. Note: Please be aware of the wire arrangement of the LVPS with the Lamp Driver. (The shorter wire should be connected to the LVPS; while the longer wire should be connected to the Lamp Driver.)	 <p>The photo illustrates the connection of two components. On the left is a larger assembly with a silver heat sink and various wires. On the right is the lamp driver PCB with two connectors. A blue arrow points from the PCB towards the larger assembly, indicating the direction of connection. The wires from the PCB are being plugged into the connectors on the larger assembly.</p>
3	Screw 4 screws to assemble the Lamp Driver Module.	 <p>The photo shows the final assembly of the lamp driver module. The PCB and housing from step 1 are now mounted onto the larger assembly from step 2. Four red circles are drawn around the screws that are being used to secure the module to the main assembly.</p>

5. Assemble Axial Fan Module

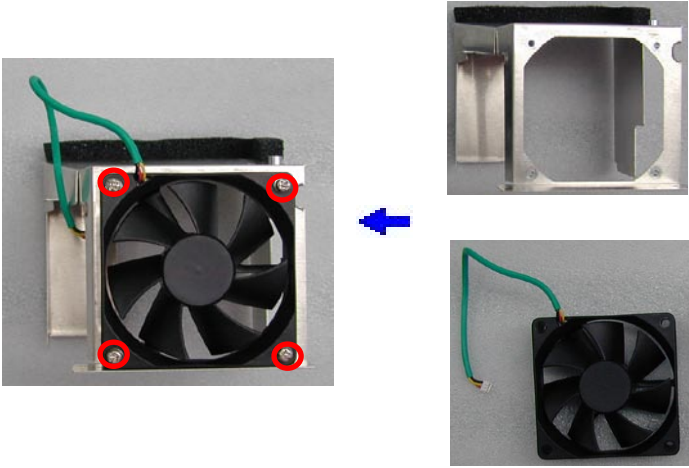
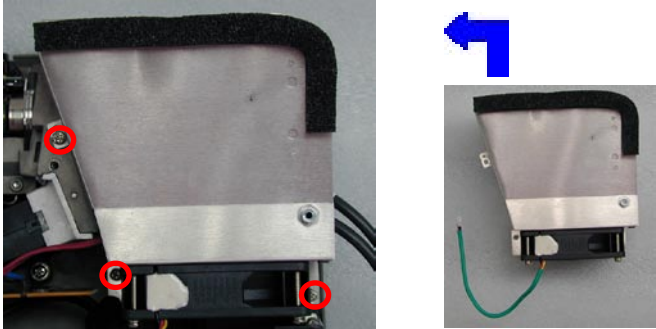
No	Procedure	Photo
1	Screw 4 screws to assemble the System Fan.	
2	Screw 3 screws to assemble Axial Fan Module. Note: Please be aware of the wire arrangement of the system fan. (the wire should be in the upper left side.)	

6. Assemble Speaker / EMI Shielding

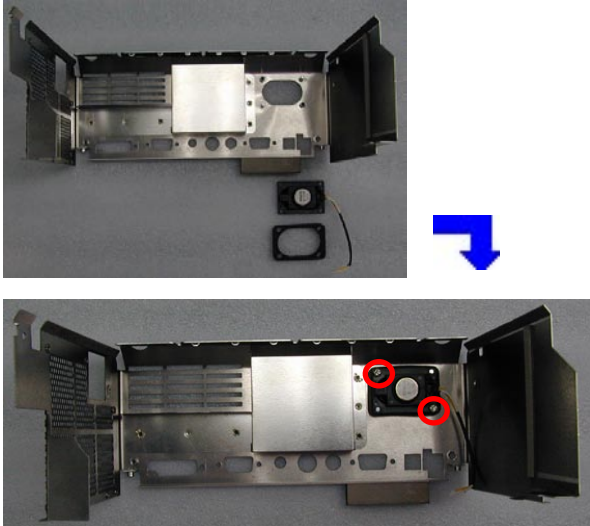
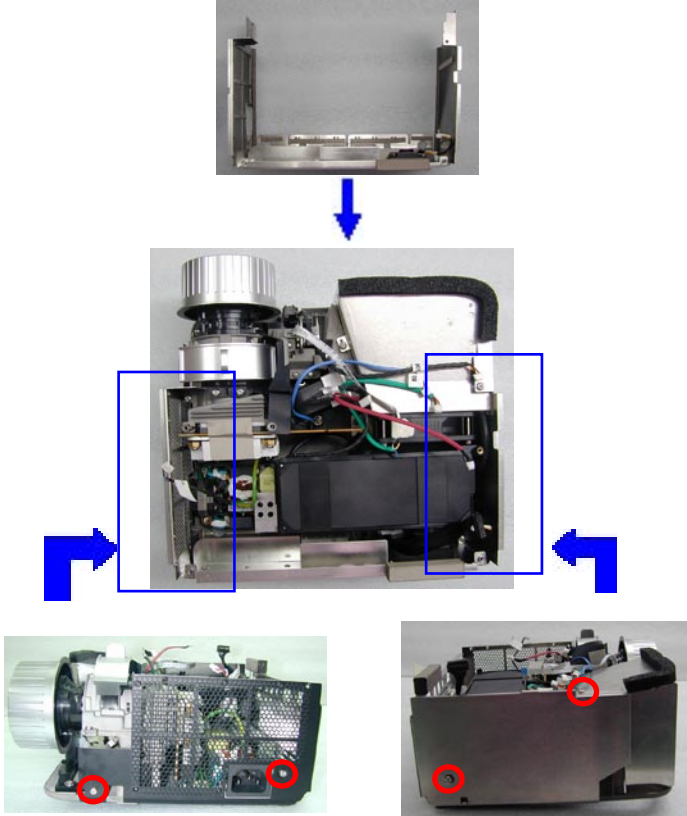
No	Procedure	Photo
1	<p>Screw 2 screws to assemble the Speaker.</p> <p>Note: Please be aware of the wire arrangement of the speaker.</p>	
2	<p>Screw 4 screws to assemble the EMI Shielding Cover of Units.</p>	

7. Assemble Main Board

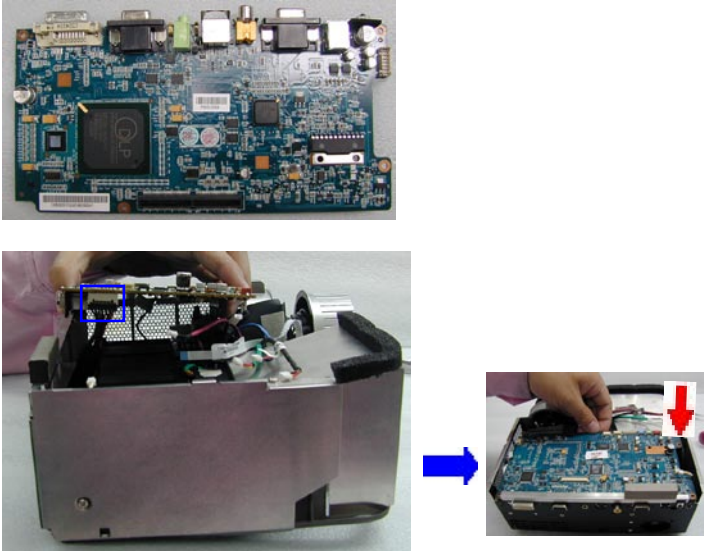
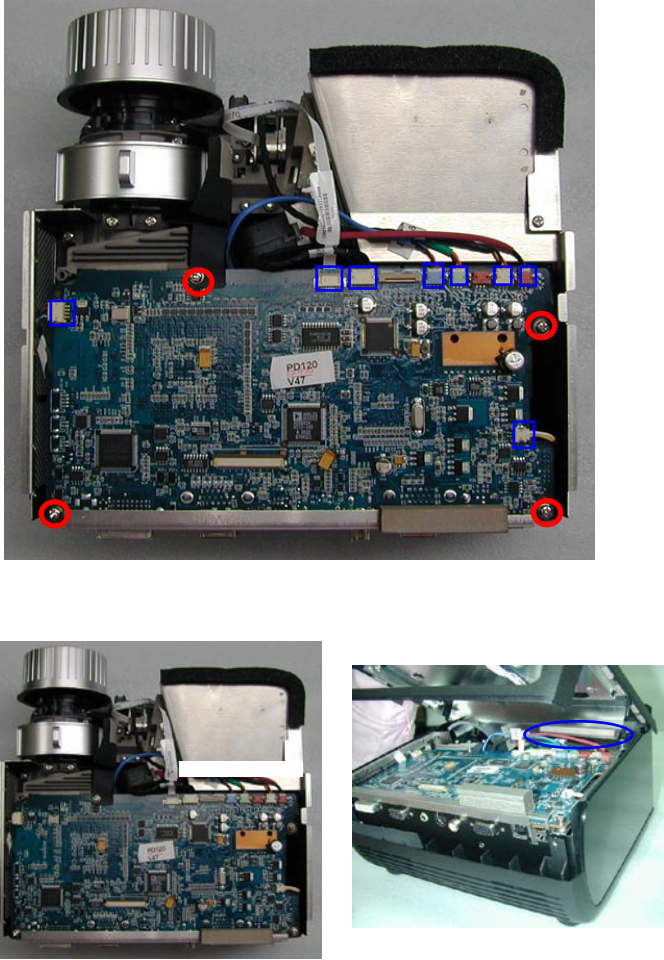
No	Procedure	Photo
1	1. Plug 1 connector. 2. Locate the front part of Main Board.	
2	Screw 4 screws and plug in 8 connectors to assemble the Main Board.	 <p data-bbox="236 1570 671 1944">Note: When Reassembling the Main Board with the Top Cover, please be aware of the wire arrangement. The wire arrangement should go as the picture shows (not exceeding 1/2 of the red blank space) to best allocate the Top Cover Sponge.</p>

8. Assemble Bottom Cover Module

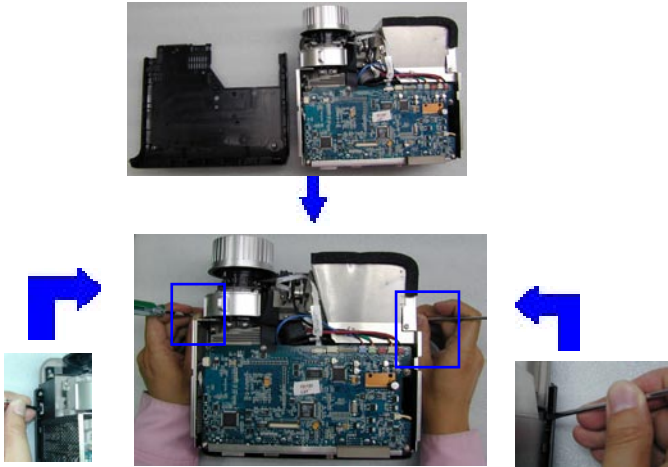
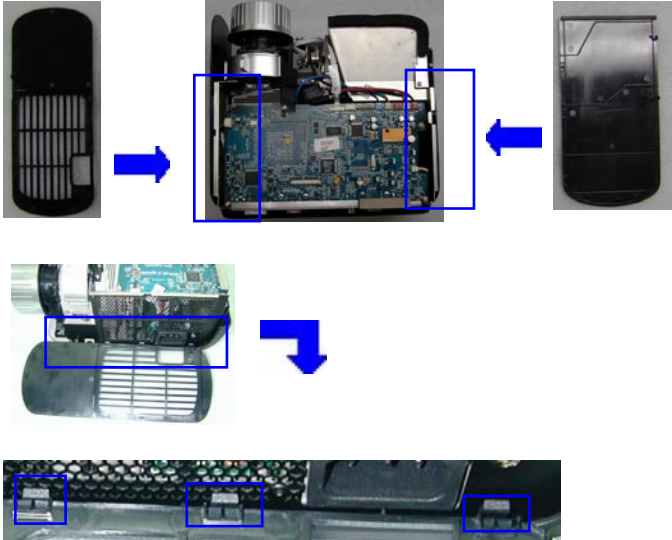
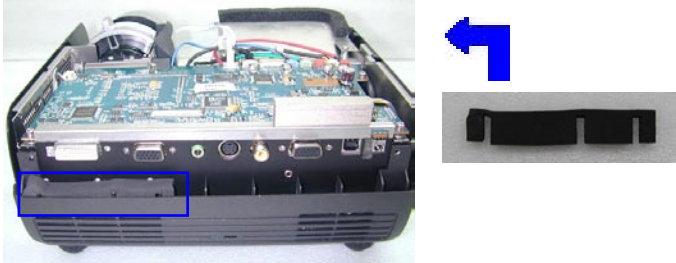
No	Procedure	Photo
1	Assemble the shieldings with the Main Unit based on the 2 tenons.	
2	Assemble Side Covers. (Right Cover & Left Cover) Note: When reassembling the Side Cover, please locate & align the tenons as the picture shows.	
3	Assemble the Bottom Cover Sponge.	

9. Assemble Front Cover / IR Sensor Board / Elevator Push Button

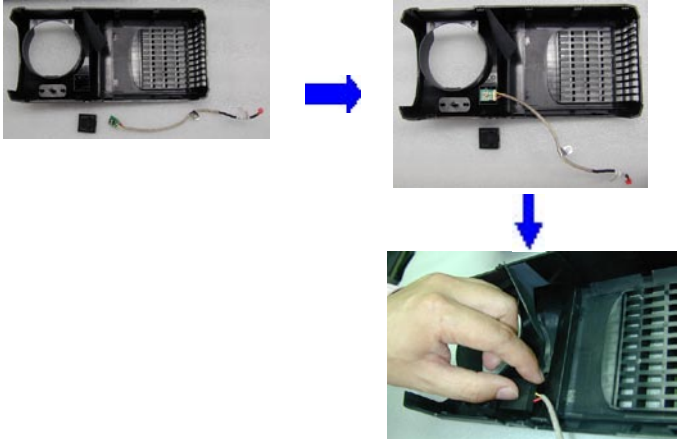
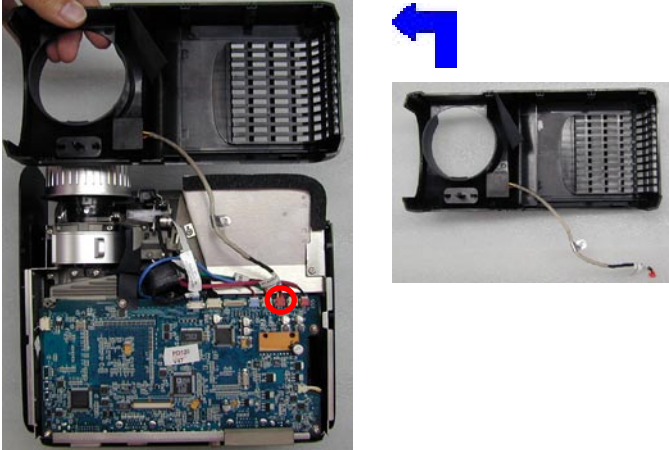
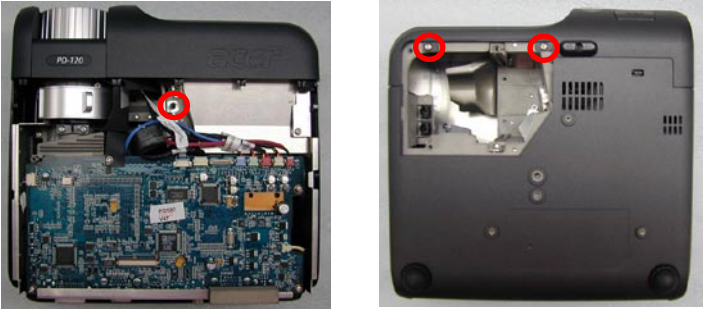
No	Procedure	Photo
1	Assemble the Elevator Push Button directly.	
2	Assemble the IR Receiver Board and put on the Front IR Cover directly.	
3	Plug in 1 connector (red color) to assemble the Front Cover Module.	
4	<p>1. Screw 1 screw to assemble the IR Receiver.</p> <p>2. Screw 2 screws to assemble the Front Cover.</p>	

10. Assemble Keypad Board

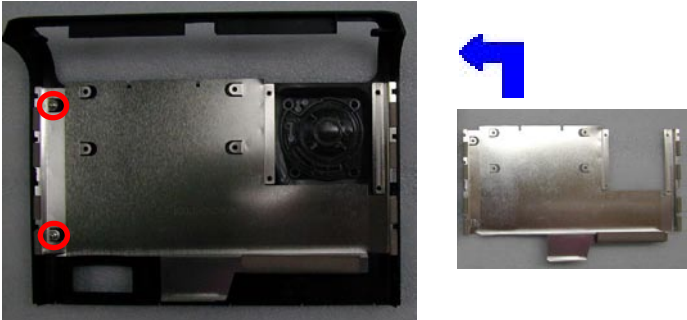
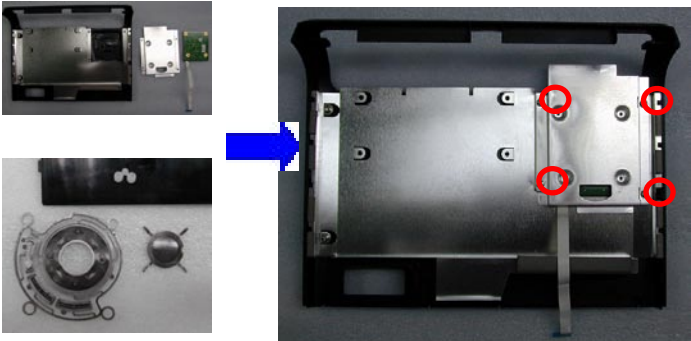
No	Procedure	Photo
1	Screw 2 screws to assemble the Top Cover Shielding.	
2	1. Assemble the Keypad Module. 2. Screw 4 screws to assemble the Keypad Board.	

11. Assemble Top Cover / IO Cover

No	Procedure	Photo
1	<p>1. Put on 1 FPC Cable to assemble the Top Cover. 2. Push the Bottom Cover first; then, push down the Top Cover to assemble the Top Cover.</p>	
2	<p>Screw 2 screws & 6 hex screws to assemble the IO Cover.</p>	

12. Assemble Lamp Module

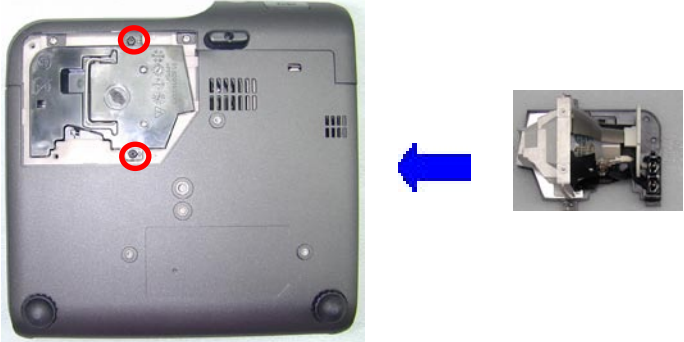
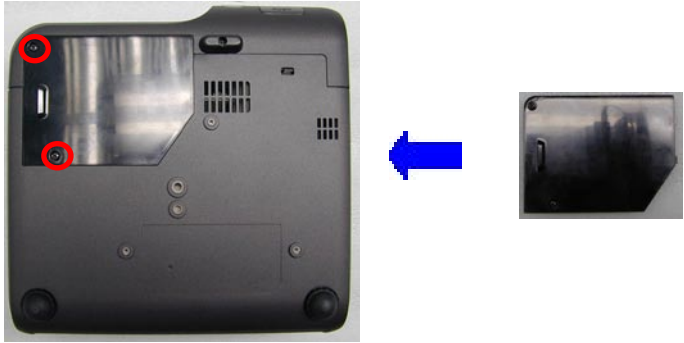
No	Procedure	Photo
1	Screw 2 screws to assemble the Lamp Module.	
2	Screw 2 screws to assemble the Lamp Cover.	

Troubleshooting

Equipment Needed

- PC or Pattern Generator
- DVD Player (Video, S-Video, Audio)
- Quantum Data 802B or CHROMA 2327

LED Lighting Message

Message	Power LED		Temp LED	Lamp LED
	Red	Blue		
Standby State (Input power cord)	Slow Flashing	○	○	○
Lamp lighting	○	*	○	○
Power on	○	*	○	○
Power off (Cooling)	Quick Flashing	○	○	○
Error (Lamp fail)	○	○	○	*
Error (Thermal fail)	○	○	*	○
Error (Fan lock fail)	○	○	Flashing	○
Error (Over Temp.)	○	○	*	○
Error (Lamp Breakdown)	○	○	○	*

* => Light On

○ => Light Off

Main Procedure

No	Symptom	Procedure
1	No Power	<ul style="list-style-type: none"> - Ensure the Power Cord and AC Power Outlet are securely connected - Check Lamp Cover and Interrupt Switch - Ensure all connectors are securely connected and aren't broken - Check DC-DC - Check Ballast - Check Main Board
2	Auto Shut Down	<ul style="list-style-type: none"> - Check LED Status <ul style="list-style-type: none"> a. Lamp LED Light <ul style="list-style-type: none"> - Check Lamp - Check Lamp Driver - Check Main Board b. Temp LED Light <ul style="list-style-type: none"> - Check Thermal Sensor - Check Thermal Switch - Check Fan c. Color Wheel <ul style="list-style-type: none"> - Check Color Wheel - Check Photo Sensor d. No Power <ul style="list-style-type: none"> - Refer to "No Power" troubleshooting
3	No Image	<ul style="list-style-type: none"> - Ensure the Signal Cable and Source work as well (If you connect multiple sources at the same time, use the "Source" button on the control panel to switch) - Ensure all connectors are securely connected and aren't broken - Check Main Board - Check DMD Board - Check Color Wheel - Check DMD Chip - Check Engine Module
4	No Light On	<ul style="list-style-type: none"> - Ensure all connectors are securely connected and aren't broken - Check Lamp Module - Check DC-DC - Check Ballast - Check Main Board
5	Mechanical Noise	<ul style="list-style-type: none"> - Check Color Wheel - Check Fan Module
6	Line Bar / Line Defect	<ul style="list-style-type: none"> - Sometimes it's because of the DMD Chip and the DMD Board did not assemble properly - Check DMD Board - Check DMD Chip - Check Main Board
7	Image Flicker	<ul style="list-style-type: none"> - Do "Reset" of the OSD Menu - Ensure the Signal Cable and Source work as well - Check Lamp Module - Check Color Wheel - Check DMD Board - Check Main Board
8	Color Abnormal	<ul style="list-style-type: none"> - Do "Reset" of the OSD Menu - Adjust Color Wheel Index - Check Main Board - Check DMD Board - Check Color Wheel

No	Symptom	Procedure
9	Poor Uniformity / Shadow	<ul style="list-style-type: none"> - Ensure the Projection Screen without dirt - Ensure the Projection Lens is clean - Ensure the Brightness is within spec. (Replace the Lamp if the Brightness is less than spec.) - Check Engine Module
10	Dead Pixel / Dust (Out of spec.)	<ul style="list-style-type: none"> - Ensure the Projection Screen without dirt - Ensure the Projection Lens is clean - Clean DMD Chip and Engine Module - Check DMD Chip - Check Engine Module
11	Garbage Image	<ul style="list-style-type: none"> - Ensure the Signal Cable and Source work as well - Check Main Board - Check DMD Board
12	Remote Control or Control Panel Failed	<ul style="list-style-type: none"> - Remote Control <ul style="list-style-type: none"> a. Check Battery b. Check Remote Control c. IR Receiver - Control Panel <ul style="list-style-type: none"> a. Check FPC b. Check Keypad c. Check Main Board
13	Function Abnormal	<ul style="list-style-type: none"> - Do "Reset" of the OSD Menu - Check Main Board - Check DMD Board

Function Test & Alignment Procedure

Product

- PD100 / PD120

Test Equipment

- IBM PC with XGA resolution (Color Video Signal & Pattern Generator)
- DVD player with Multi-system (NTSC/PAL/SECAM), equipped “Component” “S-Video” and “Composite”
- HDTV Tuner or Source (480P, 1080i)
- Minolta CL-100
- Quantum Data 802B or CHROMA2316
- After changing parts, check the information below.





Charge Parts/Update	Version Update	Color Wheel Index	ADC Calibration	Video Calibration	Reset Lamp Use Time	Factory Reset	EDID
M/B	v	v	v	v		v	v
FW	v	v	v	v		v	
Color Wheel		v					
Lamp Module					v		



Test Condition

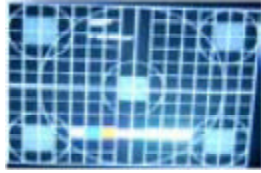
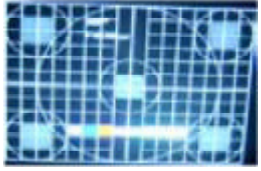

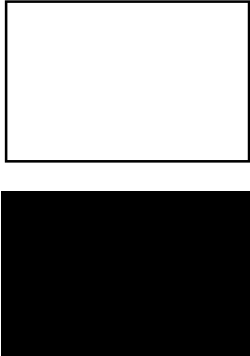

- Circumstance Brightness : Dark room less than 2.5 lux.
- Inspection Distance : 1.5m~3m for functional inspection
- Screen Size : 60 inches diagonal (wide)
- After repairing each [PD100](#), the unit should be burn-in (Refer to the table below).

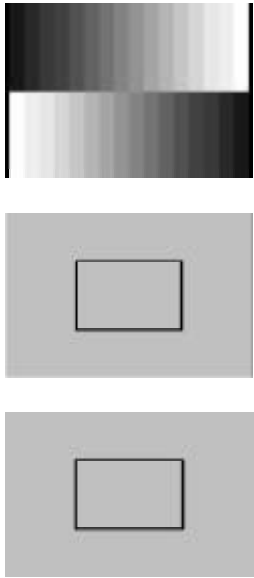
Symptom	Burn-in Time
Normal Repair	2 Hours
NFF	4 Hours
Auto Shutdown	6 Hours

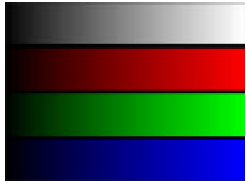
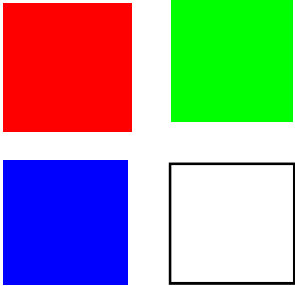

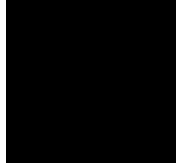

Inspection Procedure

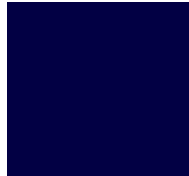
No	Step	Specification	Procedure	
1	Frequency and Tracking	Eliminate visual wavy noise by Rsync, Frequency or Tracking selection.	<ul style="list-style-type: none"> - Test Signal : 800x600@75Hz (PD100) - Test Pattern : General 1 - check and see if image sharpness and focus are well-performed. - No video noise is allowed. 	
2	Boundary	Horz. And Vert. position of video should be adjustable to be the screen frame.	<ul style="list-style-type: none"> - Test Signal : 800x600@75Hz (PD100) - Test Pattern : General 1 - Adjust Resync or Frequency / Tracking / H. Position / V. Position to the inner of the screen. 	
3	Focus	The text in the corner should be clear after adjust the focus ring.	<ul style="list-style-type: none"> - Test Signal : 800x600@75Hz (PD100) - Test Pattern : Full Screen - Adjust the center clearly; meanwhile, one slightly vague corner in the image is allowed. 	
4	HDTV	No discolor	<ul style="list-style-type: none"> - Test Signal : 480P, 1080i (PD100) - Test Pattern : Master - Equipment: Quantum Data 802B or CHROMA2327 <p><i>*Please refer to page 4~7 to enter Service Mode. Use 480P signal, smtpe bar pattern to do video calibration; then, 4:3 screen and 1080i signal. If the test result was in discoloration or flickering, please return the unit back to the repair center. (by Model)</i></p>	
5	Color Performance	<ol style="list-style-type: none"> 1. No image (discolor) 2. No light leakage 	<ul style="list-style-type: none"> - Test Signal : 800x600@75Hz (PD100) - Test Pattern : 64 RGBW Scale Pattern & 32 Grays Pattern - Please check and ensure if each color is normal and distinguishable. - If not, please adjust color index of the Engineering Mode. 	
6	Screen Uniformity	Should be compliant with 60%.(Minimum)	<ul style="list-style-type: none"> - Test Signal : 800x600@75Hz (PD100) - Test Pattern : Full White Pattern & Full Black Pattern - Please check and ensure the unit is under the spec. - Please check and see if it's in normal condition. - If not, please return the unit to repair area. <i>*Please check and see if there are dead pixels on DMD Chip.</i> - The total number and distance of dead pixels should be compliant with the spec. <p>Note:</p> <p>(1) Bright Pixel: Test Pattern: Full Black Pattern - Please check and ensure that the unit cannot accept any bright pixel. - If not, please return the unit to repair area.</p> <p>(2) Dark Pixel: Test Pattern: Full White Pattern - Please check and ensure that the pixel number should be smaller or amount to 5 pixels. - If not, please return the unit to repair area.</p>	

No	Step	Specification	Procedure	
7	Light Leak	The unit can't accept the leakage is brighter than Gray 10 pattern	<ul style="list-style-type: none"> - Test Signal : 800x600@75Hz (PD100) - Test Pattern : 32 Grays, Gray 10_HP, Gray 30_HP (From Top to Bottom) - Please check and see if the light leaks. - Follow up TI DMD Chip Spec. 	
8	Calibration	Calibration Pattern should be in full screen mode	<ul style="list-style-type: none"> - Once Main Board is changed, firmware upgrade, Video Calibration & ADC Calibration should be done as well. - Video Calibration - Test Signal : 720x480@75Hz (PD100) - Test Pattern : Master - PC Calibration - Test Signal : 800x600@75Hz (PD100) - Test Pattern : White (Top) Black (Bottom) <p>Note:</p> <ol style="list-style-type: none"> 1. Calibration Pattern should be in Full Screen Mode. 2. Please refer to 4-6. Guide to Entering Service Mode and Factory Reset for entering Service Mode. 3. Choose and access Video Calibration & PC Calibration for correction in Service Mode. Choose "Exit" to leave the Service Mode after all. 	
9	Contrast / Brightness	Gray level should be distinguishable and without color abnormal	- Test Pattern: 64 RGBW scale	
10	R, G, B and White Color Performance	Each R, G, B color should be normal without color abnormal issue	- Test Pattern: R, G, B and White Color	

No	Step	Specification	Procedure	Photo
11	Dead Pixel (Bright pixel)	Cannot accept any bright pixel	- Test Pattern : Full Black	
	Dead Pixel (Dark pixel)	The numbers of dead pixel should be smaller or amount to 6 pixel.	- Test Pattern : Full White	
12	Blemish (Bright)	The bright blemish cannot be accepted if the problem appear with Gary 30 pattern	- Test Pattern : Full Black / Gray 30	 
13	Blemish (Dark)	The dark blemish cannot be accepted if the problem appear with Blue 60 pattern.	- Test Pattern : Full white / Blue 60	 

Guide to Entering Service Mode and Factory Reset (PD100)

No	Item	Steps
1	Service Mode	<p>Please do the following steps to enter Service Mode:</p> <ol style="list-style-type: none"> 1. Turn on the projector. 2. Press "Power", "Left" button, "Left" button and "Menu" by order to enter the Service Mode. (As the following pictures show) <div style="display: flex; justify-content: space-around; align-items: flex-end;"> <div style="text-align: center;"> <p>1</p>  <p>Power</p> </div> <div style="text-align: center;"> <p>2</p>  <p>"Left" button</p> </div> <div style="text-align: center;"> <p>3</p>  <p>"Left" button</p> </div> <div style="text-align: center;"> <p>4</p>  <p>Menu</p> </div> </div>
2	Factory Reset	<p>After final QC step, we have to erase all saved change again and restore the factory defaults. The following actions will allow you to erase all end-users' settings and restore the original setting:</p> <ol style="list-style-type: none"> 1. Please enter the service mode, 2. Choose "Factory Reset" then choose "Yes" and press "Enter" to see if it works.

Exploded Overview

PD100 Exploded Overview

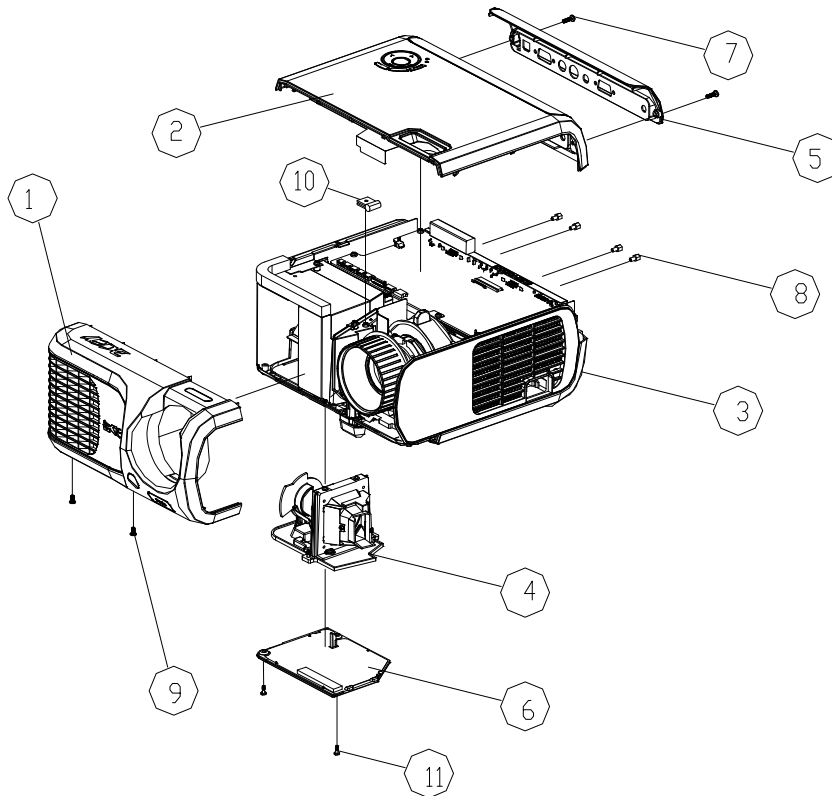

Exploded Parts List

Item	Part Number	Description
1	70.82V22G001	ASSY FRONT COVER MODULE PD100
2	70.82V24G001	ASSY TOP COVER MODULE PD100
3	70.82V15G001	ASSY BOTTOM HOUSING MODULE PD100
4	70.82G09G001	ASSY LAMP MODULE EP7190
5	70.82V23G001	ASSY BACK COVER DC MODULE PD100
6	70.82V33G001	ASSY LAMP COVER MODULE PD100
7	85.1A323.100	SCREW PAN MECH M3*10 BLACK
8	85.005AGG040	SCREW I/O STEEL #4-40UNC*H4*L5.5 NYLOK
9	85.5A323.060	SCREW BIN MECH M3*6 Black
10	61.00079G001	GROUNDING CABLE CLAMP FN-008 "PINGOOD"
11	61.00018G002	LOCK SCREW PAN MECH M3*8.5-3.5 BLACK

Note: Please refer to RSPL for updated Part Number.

PD120 Exploded Overview

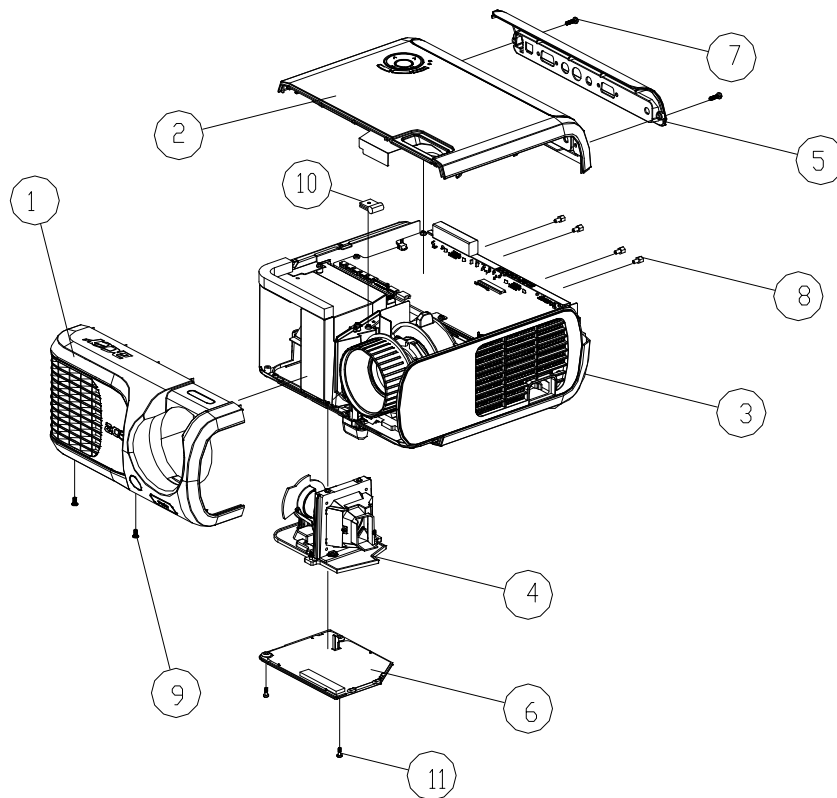

Exploded Parts List

Item	Part Number	Description
1	70.82V03G001	ASSY FRONT COVER MODULE PD120
2	70.82V07G001	ASSY TOP COVER MODULE PD120
3	70.82V01G001	ASSY BOTTOM HOUSING MODULE PD120
4	70.82G09G001	ASSY LAMP MODULE EP7190
5	70.82V14G001	ASSY BACK COVER DC MODULE PD120
6	70.82V32G001	ASSY LAMP COVER MODULE PD120
7	85.1A323.100	SCREW PAN MECH M3*10 BLACK
8	85.005AGG040	SCREW I/O STEEL #4-40UNC*H4*L5.5 NYLOK
9	85.5A323.060	SCREW BIN MECH M3*6 Black
10	61.00079G001	GROUNDING CABLE CLAMP FN-008 "PINGOOD
11	61.00018G002	LOCK SCREW PAN MECH M3*8.5-3.5 BLACK

Note: Please refer to RSPL for updated Part Number.

PD100 Assy Bottom Housing Module

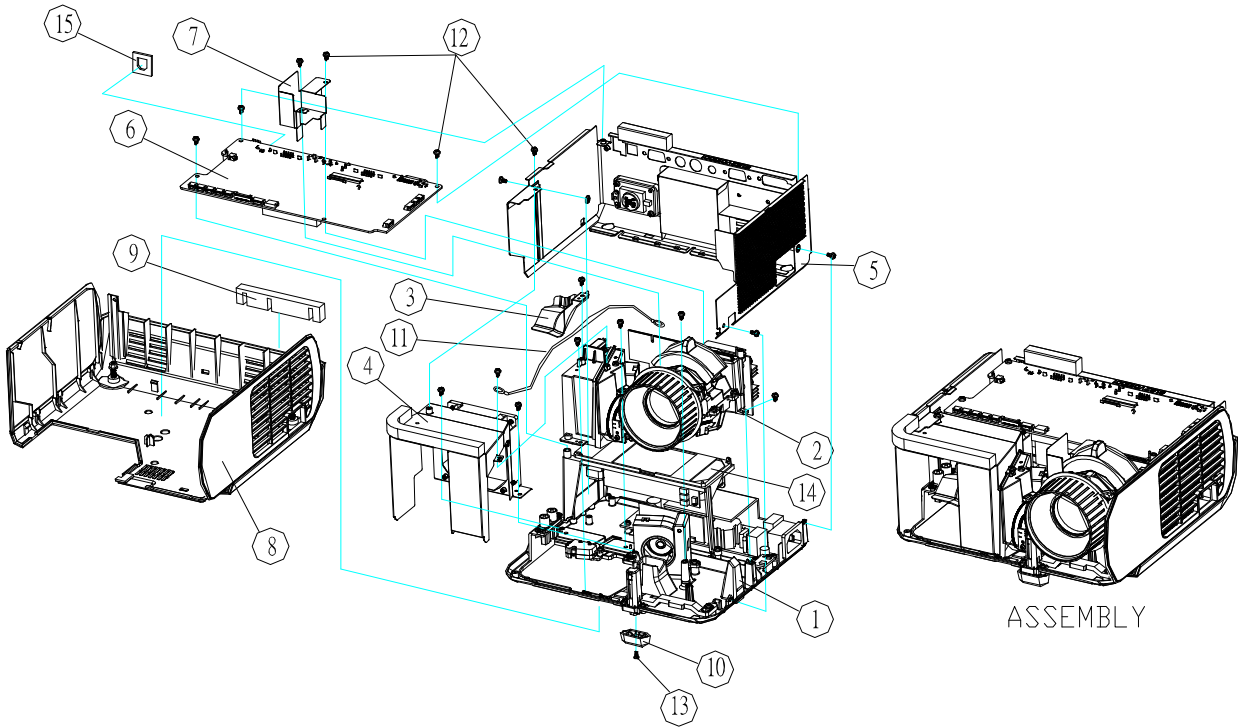

Exploded Parts List

Item	Part Number	Description
1	70.82V09G001	ASSY BOTTOM BASE MODULE PD120
2	70.82V17G001	ASSY ENGINE MODULE PD100
3	61.82G12G001	LAMP LIGHTCUT TOP FOR E19 AL 0.6t EP7190
4	70.82V10G001	ASSY AXIAL FAN MODULE PD120
5	70.82V04G001	ASSY BOTTOM EMI SHIELDING MODULE PD120
6	80.82V51G001	PCBA MAIN BD PD100
7	51.82V19G001	ZOOM RING MYLAR PD120
8	70.82V25G001	ASSY BOTTOM COVER MODULE PD100
9	52.82V04G001	BOTTOM COVER SPONGE PD120
10	51.82G16G001	ELEVATOR FOOT PC+ABS C6200 EP7190 "GREEN"
11	42.87120G001	W.A. GROUND #20 UL1007 BLACK 80mm p3.0/p3.0 LT20
12	85.1A123.050	SCREW PAN MECH M3*5 Ni
13	85.1A626G050	SCREW PAN MECH M2.6*5 BLACK NYLOK
14	70.82G19G001	ASSY LAMP DRIVER MDULE EP7190
15	41.82G03G001	EMI GASKET USB CONNECTOR EP719

Note: Please refer to RSPL for updated Part Number.

PD120 Assy Bottom Housing Module

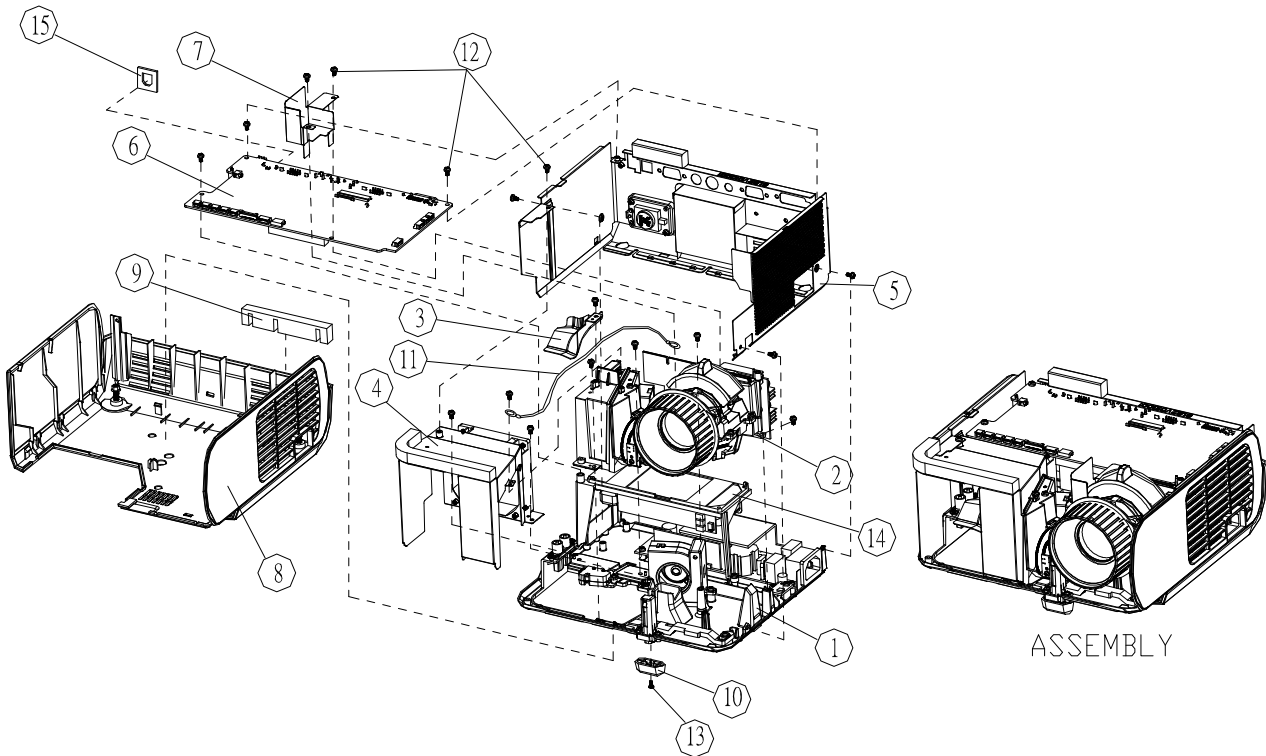

Exploded Parts List

Item	Part Number	Description
1	70.82V09G001	ASSY BOTTOM BASE MODULE PD120
2	70.82V11G001	ASSY ENGINE MODULE PD120
3	61.82G12G001	LAMP LIGHTCUT TOP FOR E19 AL 0.6t EP7190
4	70.82V10G001	ASSY AXIAL FAN MODULE PD120
5	70.82V04G001	ASSY BOTTOM EMI SHIELDING MODULE PD120
6	80.82V01G001	PCBA MAIN BD PD120
7	51.82V19G001	ZOOM RING MYLAR PD120
8	70.82V02G001	ASSY BOTTOM COVER MODULE PD120
9	52.82V04G001	BOTTOM COVER SPONGE PD120
10	51.82G16G001	ELEVATOR FOOT PC+ABS C6200 EP7190 "GREEN"
11	42.87120G001	W.A. GROUND #20 UL1007 BLACK 80mm p3.0/p3.0 LT20
12	85.1A123.050	SCREW PAN MECH M3*5 Ni
13	85.1A626G050	SCREW PAN MECH M2.6*5 BLACK NYLOK
14	70.82G19G001	ASSY LAMP DRIVER MDULE EP7190
15	41.82G03G001	EMI GASKET USB CONNECTOR EP719

Note: Please refer to RSPL for updated Part Number.

PD100 Assy Bottom Cover Module

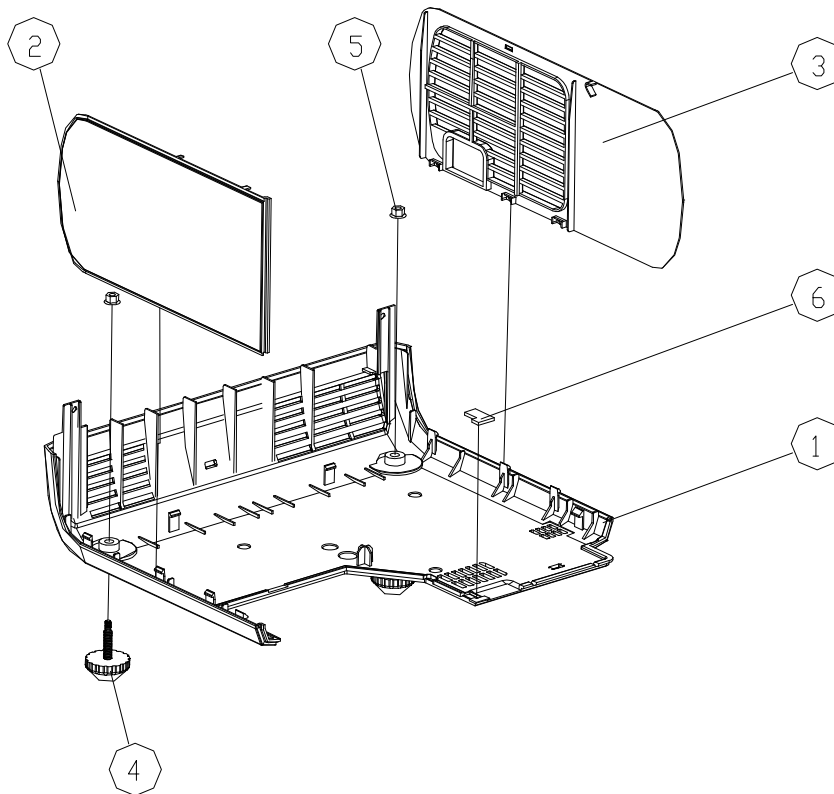

Exploded Parts List

Item	Part Number	Description
1	51.82V02G002	BOTTOM COVER PC+ABS PD100
2	51.82V17G001	LEFT COVER PC+ABS PD120
3	51.82V18G001	RIGHT COVER PC+ABS PD120
4	52.89601.001	ADJUST FOOT RUBBER EP759
5	86.03123.035	HEX CAP HEAD NUT M3*0.5P L3.5 NI
6	52.82V10G001	BOTTOM COVER SPONGE-2 PD120

Note: Please refer to RSPL for updated Part Number.

PD120 Assy Bottom Cover Module

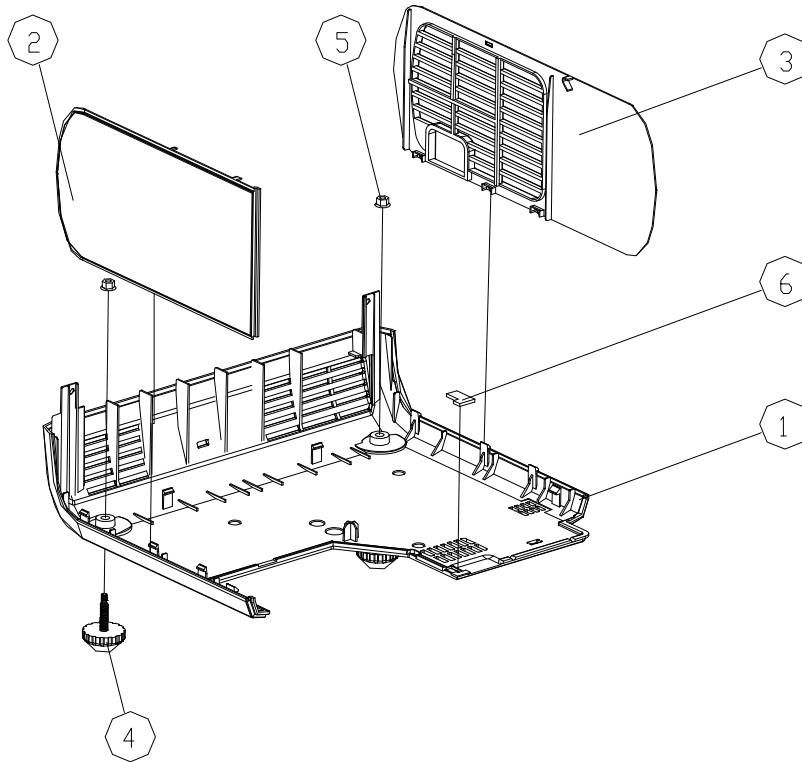

Exploded Parts List

Item	Part Number	Description
1	51.82V02G001	BOTTOM COVER PC+ABS PD120
2	51.82V17G001	LEFT COVER PC+ABS PD120
3	51.82V18G001	RIGHT COVER PC+ABS PD120
4	52.89601.001	ADJUST FOOT RUBBER EP759
5	86.03123.035	HEX CAP HEAD NUT M3*0.5P L3.5 NI
6	52.82V10G001	BOTTOM COVER SPONGE-2 PD120

Note: Please refer to RSPL for updated Part Number.

PD120 Assy Bottom Base Module

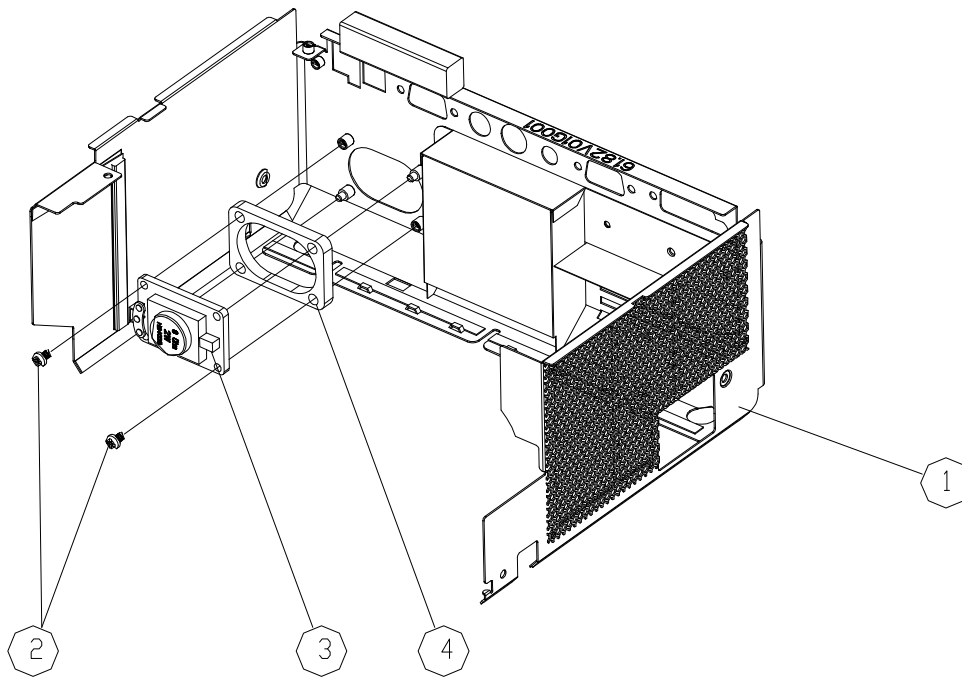

Exploded Parts List

Item	Part Number	Description
1	49.88604.002	SPEAKER 8ohm 2W X16 EP759
2	85.1A123.050	SCREW PAN MECH M3*5 Ni
3	52.82G11G001	SPEAKER SPONGE EP7190
4	61.82V01G001	EMI SHIELDING AL PD120

Note: Please refer to RSPL for updated Part Number.

PD100 Assy Top Cover Module

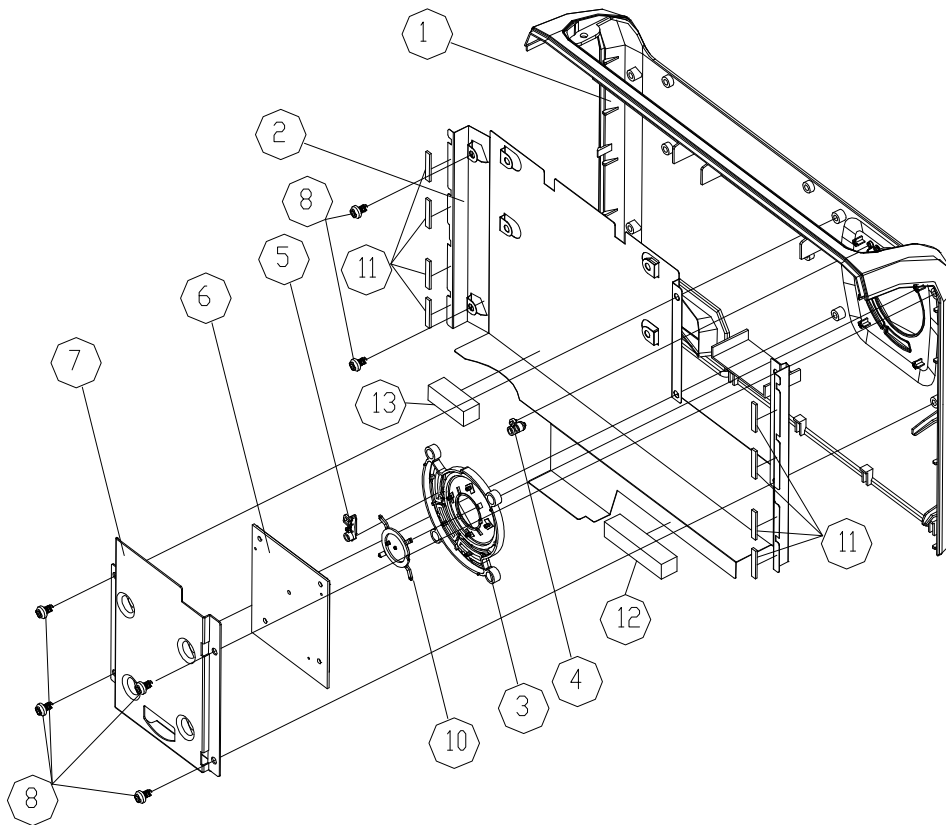

Exploded Parts List

Item	Part Number	Description
1	51.82V03G001	TOP COVER PC+ABS PD120
2	61.82V04G001	TOP COVER SHIELDING SPTPE PD120
3	51.82Q03G001	KEYPAD MAIN BUTTON PC+ABS PD322
4	51.82Q05G001	LED HOUSING PC PD322
5	51.82Q06G001	POWER LED HOUSING PC PD322
6	80.82Q03G001	PCBA KEYPAD BOARD PD322 "GREEN"
7	61.82V03G001	KEYPAD SHIELDING AL PD120
8	85.WA123.040	SCREW PAN TAP M3*4 Ni
9	42.82V02G001	CABLE FFC 14P P=0.5 120mm PD120
10	51.82Q04G011	KEYPAD MENU BUTTON PC+ABS PD120
11	41.82V05G001	EMI GASKET W4*H3*L15mm PD120
12	41.82V04G001	EMI GASKET W10*H6.5*L70mm PD120
13	41.81M02G001	EMI GASKET W17*H23*L30mm

Note: Please refer to RSPL for updated Part Number.

PD120 Assy Top Cover Module

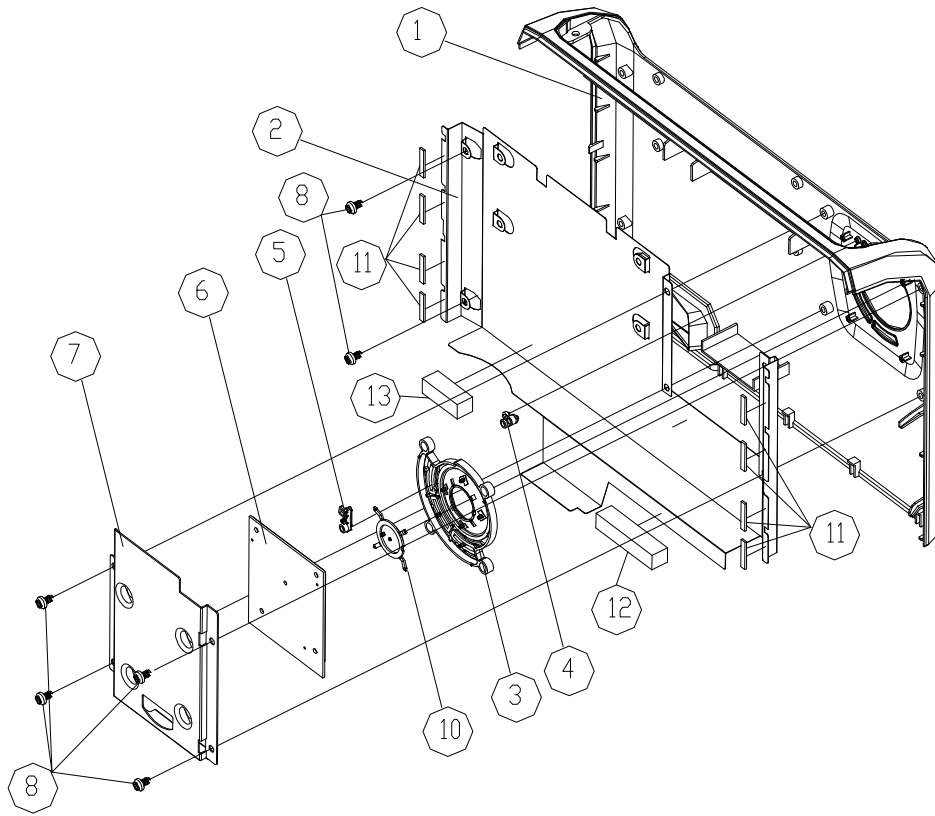

Exploded Parts List

Item	Part Number	Description
1	51.82V03G001	TOP COVER PC+ABS PD120
2	61.82V04G001	TOP COVER SHIELDING SPTE PD120
3	51.82Q03G001-B	KEYPAD MAIN BUTTON PC+ABS PD322
4	51.82Q05G001	LED HOUSING PC PD322
5	51.82Q06G001-B	POWER LED HOUSING PC PD322
6	80.82Q03G001	PCBA KEYPAD BOARD PD322 "GREEN"
7	61.82V03G001	KEYPAD SHIELDING AL PD120
8	85.WA123.040	SCREW PAN TAP M3*4 Ni
9	42.82V02G001	CABLE FFC 14P P=0.5 120mm PD120
10	51.82Q04G011	KEYPAD MENU BUTTON PC+ABS PD120
11	41.82V05G001	EMI GASKET W4*H3*L15mm PD120
12	41.82V04G001	EMI GASKET W10*H6.5*L70mm PD120
13	41.81M02G001	EMI GASKET W17*H23*L30mm

Note: Please refer to RSPL for updated Part Number.

PD120 Assy Bottom Base Module

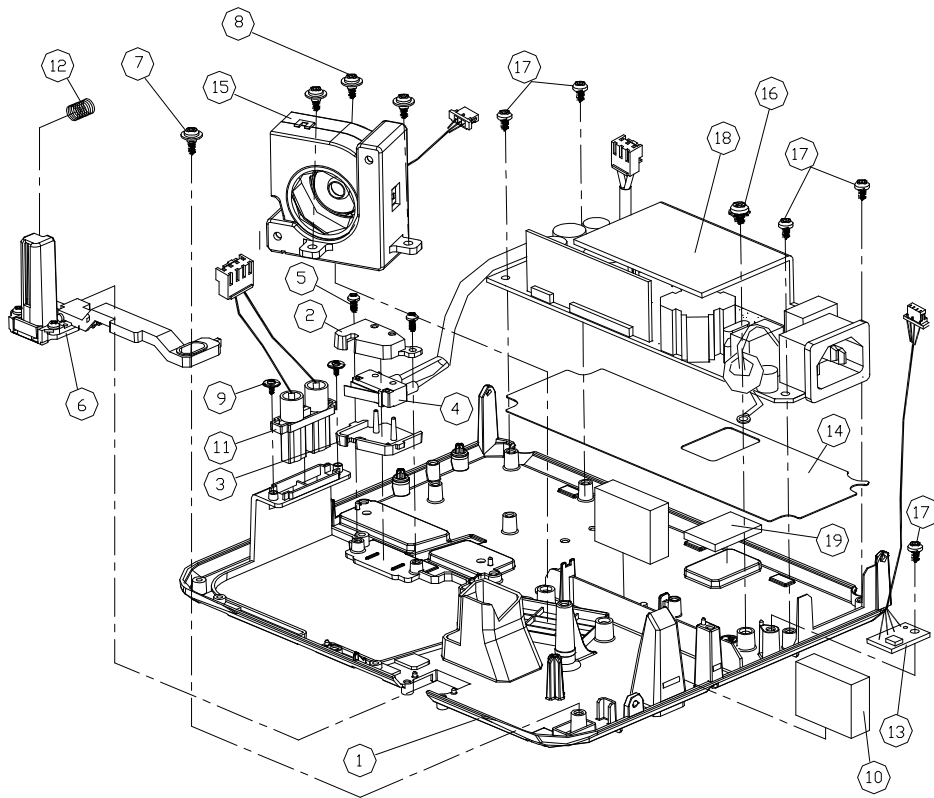

Exploded Parts List

Item	Part Number	Description
1	61.82G01G001	BASE PLATE Mg ALLOY AZ91D EP7190
2	51.85816.001	LIMIT SWITCH HOLDER PPS XB31
3	51.85824.001	LIMIT SWITCH BOTTOM HOLDER PPS XB31
4	75.88514.002	ASSY LIMIT SWITCH CHERRY DB3C A1LB-5A
5	85.1A62G.050	SCREW PAN MECH M2.6*5 BLACK NYLOK
6	70.82V34G001	ASSY ELEVATOR MODULE PD120
7	61.00029.001	SCREW PAN MECH M3*5*D8 Ni
8	61.87340G001	STAND OFF M3*4L D8.0 2100MP
9	85.3A122.040	SCREW CAP MECH M2*4 Ni
10	41.82V01G001	EMI GASKET W17*H27*L35mm PD120
11	76.82G01G001	BUY ASSY W.A. 2P 150mm LVPS/LAMP EP719
12	61.85913.001	ELEVATOR SPRING SUS304 SB21
13	80.82V04G001	PCBA THERMAL SENSOR BOARD PD120
14	51.82G24G001	BASE PLATE INSULATION MYLAR FOR LVPS EP7190
15	70.82V26G001	ASSY BLOWER FAN MODULE PD120
16	85.1C224G050	SCREW PAN MECH M4*5 COLOR W/TOOTH WASHER
17	85.1A123.050	SCREW PAN MECH M3*5 Ni
18	70.82V31G001	ASSY LVPS MODULE PD120
19	52.88504G001	LVPS BOTTOM THERMAL PAD 26*21*3mm Fujipoly GR-b

Note: Please refer to RSPL for updated Part Number.

PD120 Assy Axial Fan Module

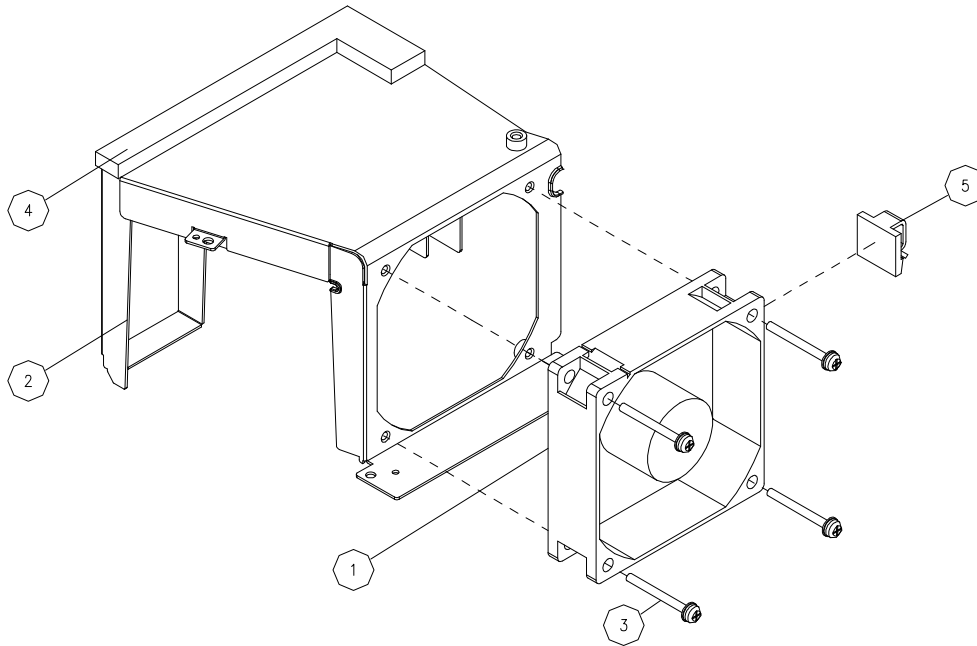

Exploded Parts List

Item	Part Number	Description
1	49.80N01G001	SUNON 70*20 R-TYPE AXIAL FAN, GM1207PKVX-A 70*70*20mm, JST CONNECTOR, GREEN SUMITUDE
2	61.82V02G001	FAN-LAMP BRACKET AL PD120
3	85.1F123.260	SCREW PAN MECH E/SF M3*26 Ni
4	52.82V07G001	LAMP BRACKET SPONGE PD120
5	51.00075.001	WIRE MOUNTS PG-FW-4D XB31

Note: Please refer to RSPL for updated Part Number.

PD100 Assy Engine Module

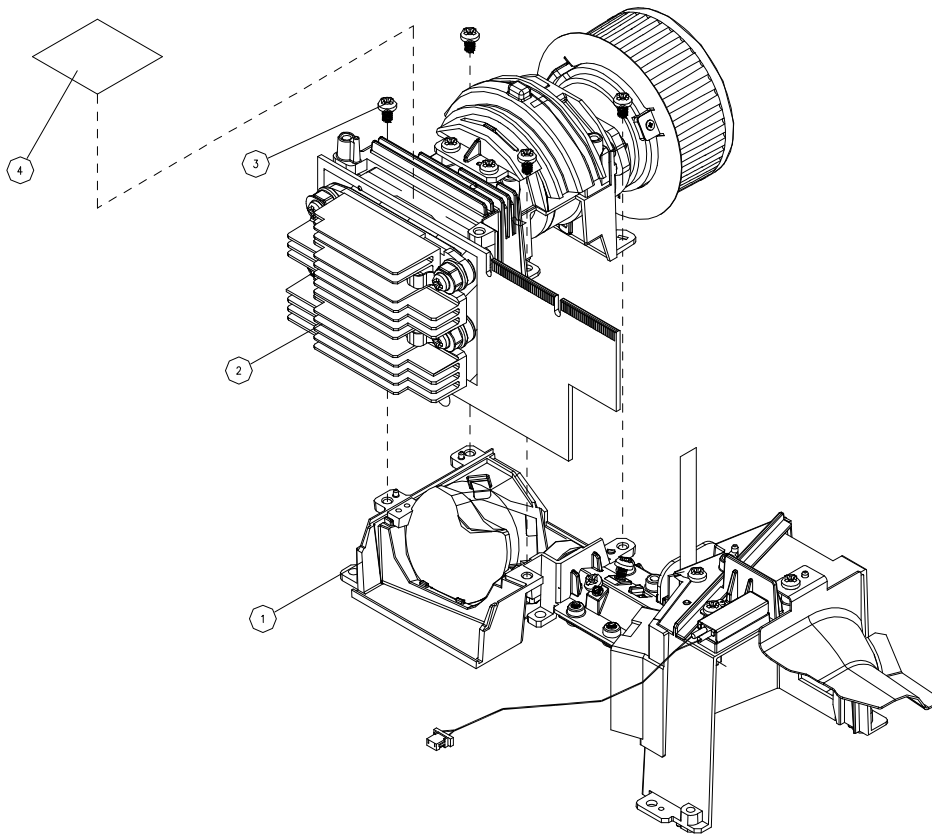

Exploded Parts List

Item	Part Number	Description
1	70.82V27G001	ASSY ENGINE BOTTOM COVER MODULE PD120
2	70.82V18G001	ASSY ENGINE TOP MODULE PD100
3	85.1A123.050	SCREW PAN MECH M3*5 Ni
4	41.82V02G001	EMI TAPE W30*L30mm PD120

Note: Please refer to RSPL for updated Part Number.

PD120 Assy Engine Module

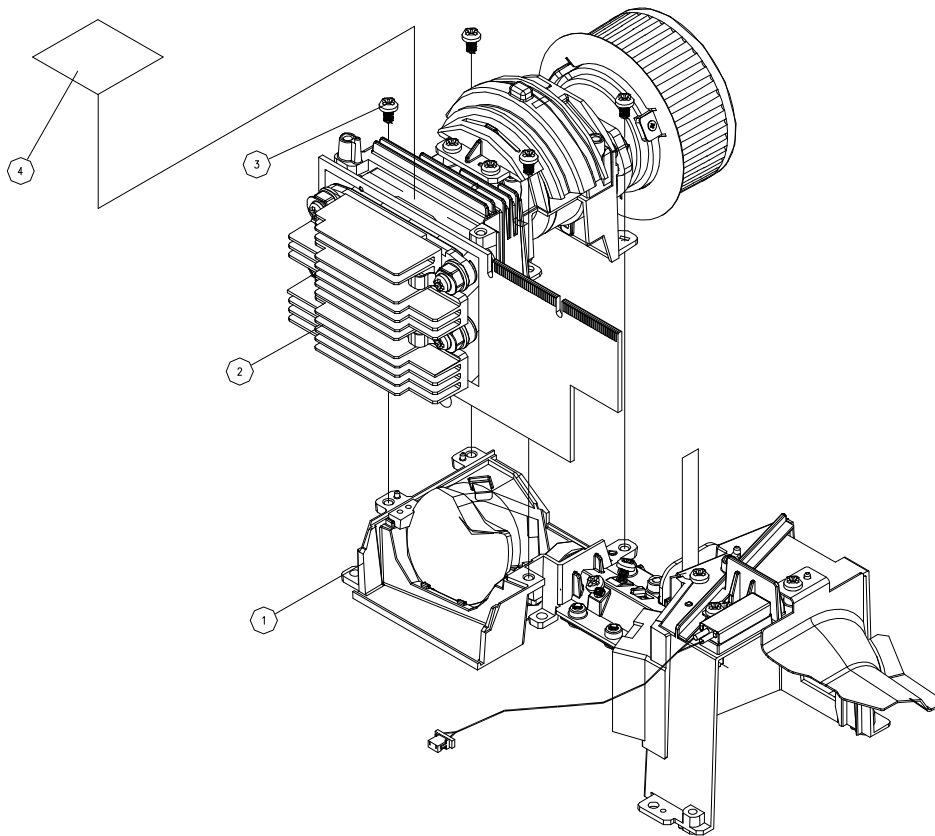

Exploded Parts List

Item	Part Number	Description
1	70.82V27G001	ASSY ENGINE BOTTOM COVER MODULE PD120
2	70.82V12G001	ASSY ENGINE TOP MODULE PD120
3	85.1A123.050	SCREW PAN MECH M3*5 Ni
4	41.82V02G001	EMI TAPE W30*L30mm PD120

Note: Please refer to RSPL for updated Part Number.

PD100 Assy Engine Top Cover Module

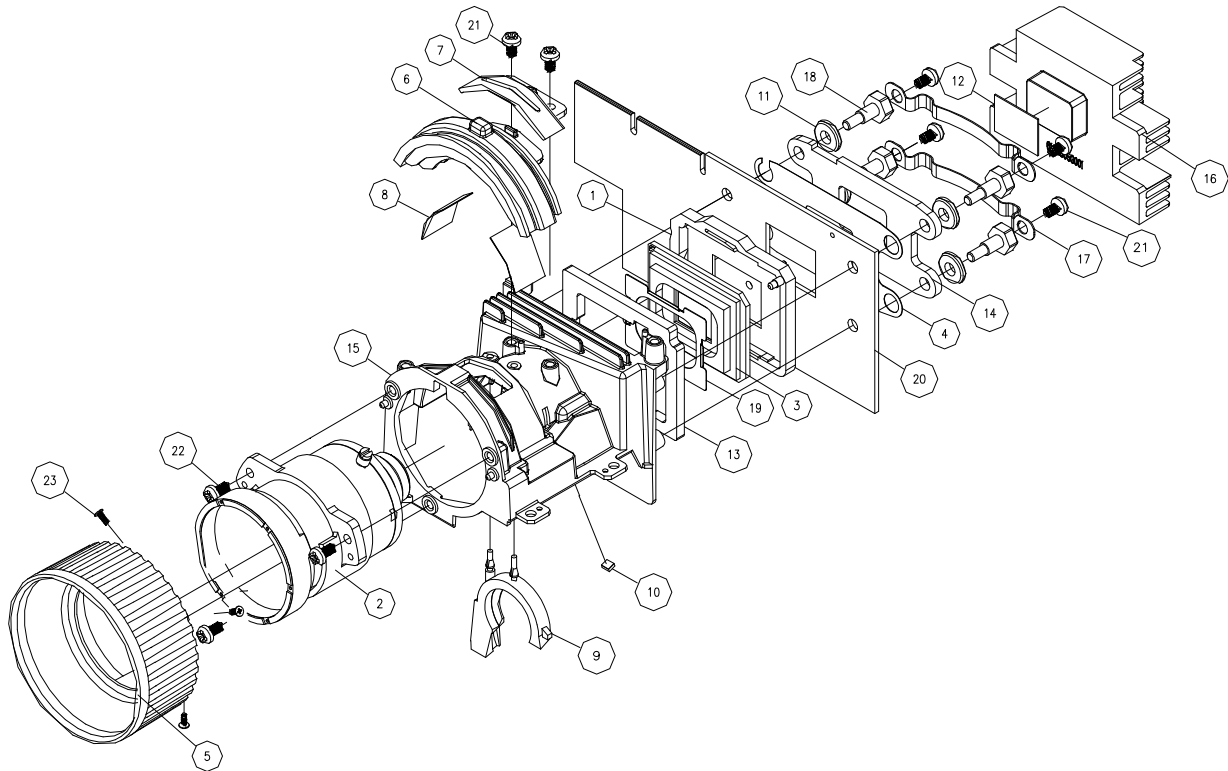

Exploded Parts List

Item	Part Number	Description
1	11.009F0G005-C	CNNT F 166P FOR 0.55" SVGA LGA DMD SOCKET;FOXCONN
2	23.82G01G002	PROJECTION LENS BARREL CHA
3	48.859DMGD13	
4	51.80B31G002	DMD INSULATOR MYLAR 0.435t T90
5	51.82V09G001	FOCUS RING PC+ABS PD120
6	51.82V10G001	ZOOM RING PC+ABS PD120
7	51.82G08G001	ZOOM RING ORBIT PC+ABS C6200 EP7190
8	51.82G22G001	ZOOM ANTI-ABRASION TEFLON EP7190
9	52.82G03G002	RELAY SEALED RUBBER-2 EP719
10	52.82G10G001	RELAY CUSHION RUBBER EP7190
11	52.87130G001	RUBBER BLOWER 595925
12	52.87319G001	DMD THERMAL PAD 18*13*0.5t
13	52.89627G002	DMD SEAL RUBBER BF1000 3.2t EP719
14	61.80J48G002	DMD HEATSINK BACKER PLATE A6061 739
15	61.82G02G001	ENGINE TOP COVER Mg ALLOY AZ91D EP7190
16	61.83A03G001	DMD HEATSINK AL 1070 DP718
17	61.88608G001	DMD HEATSINK SPRING PLATE SUS301 0.4t ly10X
18	61.88611G001	DMD SCREW ly10X
19	61.89643G001	DMD MASK PLATE SUS301 0.15t EP759
20	00.82V02G001	BARE PCB L:6 DMD BD FOR PD120
21	85.1A123.050	SCREW PAN MECH M3*5 Ni
22	85.1A123.060	SCREW PAN MECH M3*6 Ni
23	85.YA321G051	SCREW FLAT HEAD TAP M1.7x5 D3 BALCK

Note: Please refer to RSPL for updated Part Number.

PD120 Assy Engine Top Cover Module

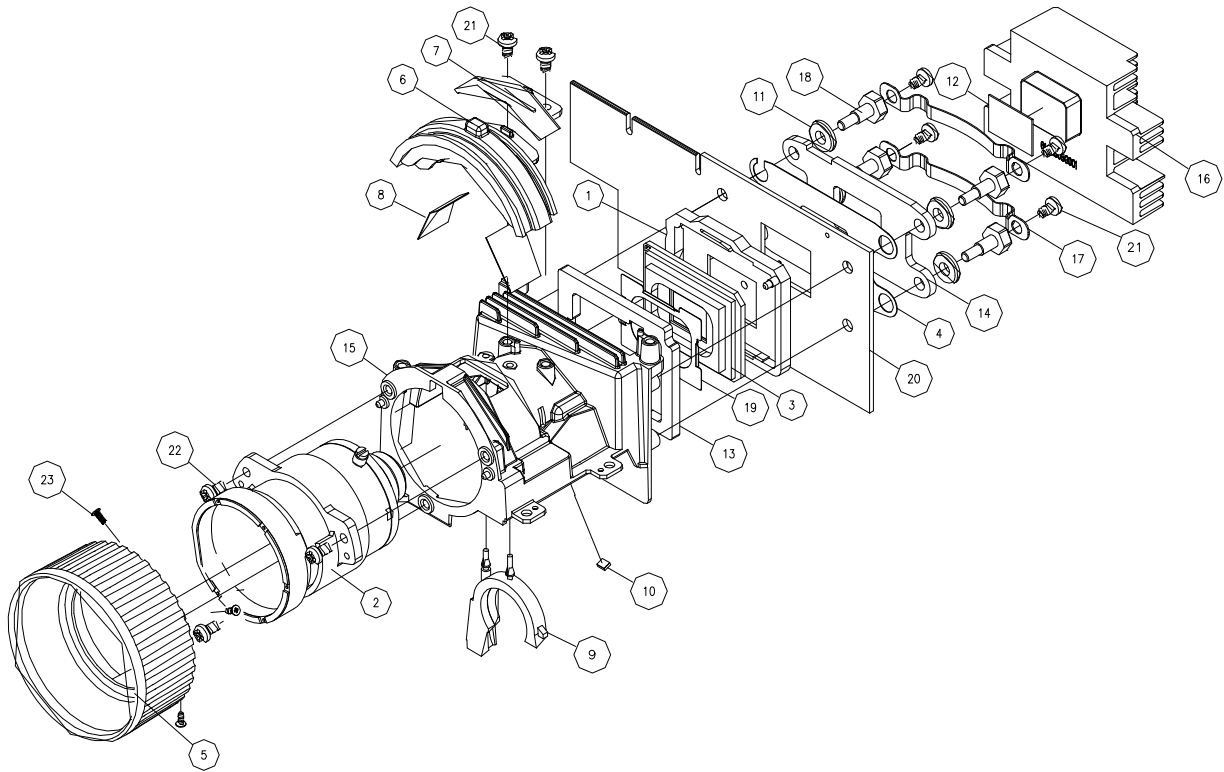

Exploded Parts List

Item	Part Number	Description
1	11.009F0G005	CNNT F 166P FOR 0.55" SVGA LGA DMD SOCKET;FOXCONN
2	23.82G01G002	PROJECTION LENS BARREL CHA
3	48.82GDMGD01	DMD 1024*768 PIXEL DDR FTP 0.55" XGA
4	51.80B31G002	DMD INSULATOR MYLAR 0.435t T90
5	51.82V09G001	FOCUS RING PC+ABS PD120
6	51.82V10G001	ZOOM RING PC+ABS PD120
7	51.82G08G001	ZOOM RING ORBIT PC+ABS C6200 EP7190
8	51.82G22G001	ZOOM ANTI-ABRASION TEFLON EP7190
9	52.82G03G002	RELAY SEALED RUBBER-2 EP719
10	52.82G10G001	RELAY CUSHION RUBBER EP7190
11	52.87130G001	RUBBER BLOWER 595925
12	52.87319G001	DMD THERMAL PAD 18*13*0.5t
13	52.89627G002	DMD SEAL RUBBER BF1000 3.2t EP719
14	61.80J48G002	DMD HEATSINK BACKER PLATE A6061 739
15	61.82G02G001	ENGINE TOP COVER Mg ALLOY AZ91D EP7190
16	61.83A03G001	DMD HEATSINK AL 1070 DP718
17	61.88608G001	DMD HEATSINK SPRING PLATE SUS301 0.4t ly10X
18	61.88611G001	DMD SCREW ly10X
19	61.89643G001	DMD MASK PLATE SUS301 0.15t EP759
20	00.82V02G001-B	BARE PCB L:6 DMD BD FOR PD120
21	85.1A123.050	SCREW PAN MECH M3*5 Ni
22	85.1A123.060	SCREW PAN MECH M3*6 Ni
23	85.YA321G051	SCREW FLAT HEAD TAP M1.7x5 D3 BALCK

Note: Please refer to RSPL for updated Part Number.

PD120 Assy Back Cover DC Module

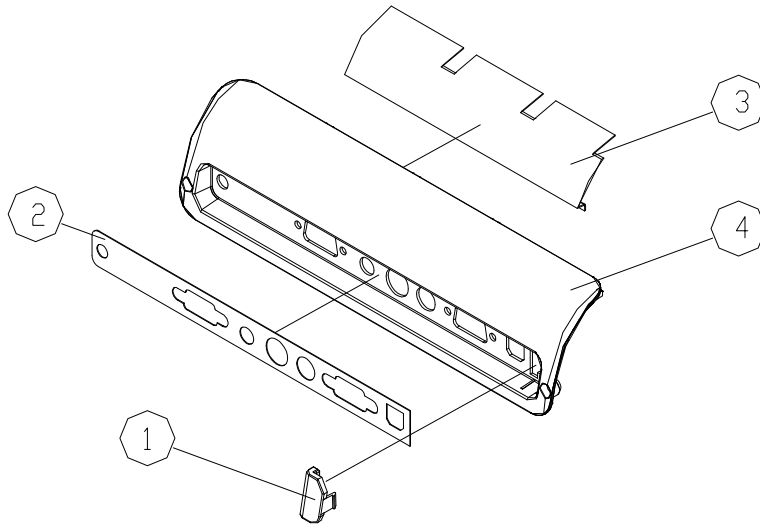

Exploded Parts List

Item	Part Number	Description
1	51.82V12G001	BACK IR LENS PC PD120
2	51.82V21G001	BACK IO OVERLAY-DC PC PD120
3	41.82V12G001	EMI TAPE W41*L129mm PD120
4	51.82V04G011	BACK COVER-DC PC+ABS PD120

Note: Please refer to RSPL for updated Part Number.

PD100 Assy Back Cover DC Module

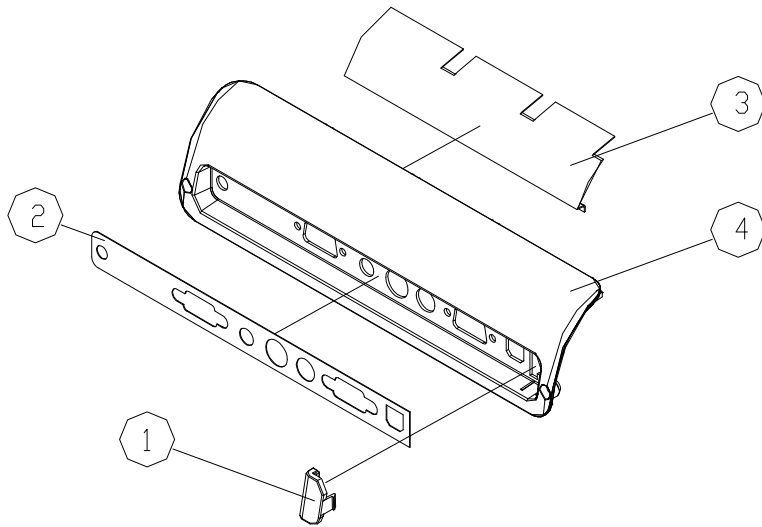

Exploded Parts List

Item	Part Number	Description
1	51.82V12G001	BACK IR LENS PC PD120
2	51.82V21G001	BACK IO OVERLAY-DC PC PD120
3	41.82V12G001	EMI TAPE W41*L129mm PD120
4	51.82V04G012	BACK COVER-DC PC+ABS PD100

Note: Please refer to RSPL for updated Part Number.

PD100 Assy Front Cover

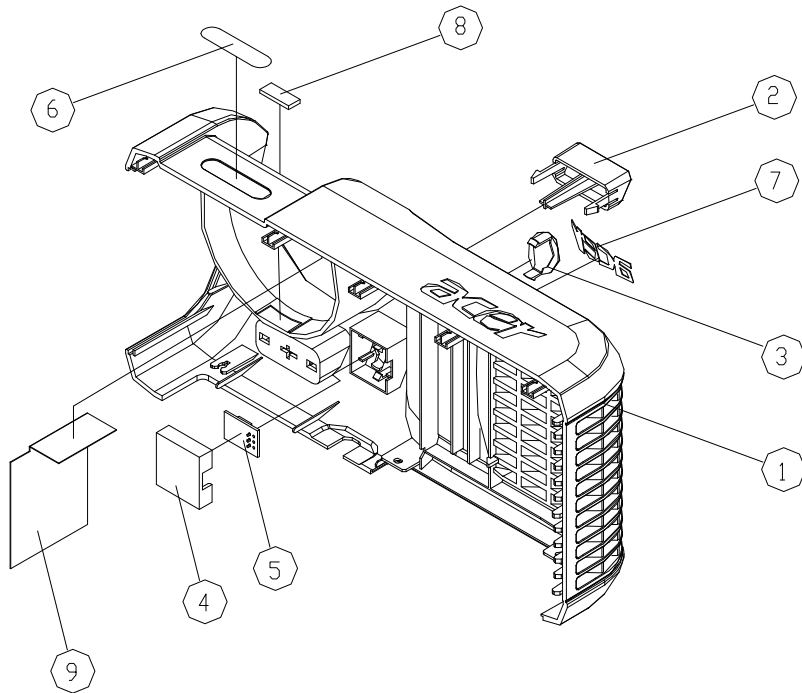

Exploded Parts List

Item	Part Number	Description
1	51.82V01G002	FRONT COVER NORYL 9406P PD100
2	51.82V08G002	FRONT PUSH BUTTON PC+ABS PD100
3	51.82V11G001	FRONT IR LENS PC PD120
4	52.82V02G001	FRONT IR COVER RUBBER PD120
5	80.82V05G001	PCBA IR SENSOR BD FOR PD120
6	35.82V01G002	MODEL NAME LABEL PC PD100
7	35.82V03G001	ACER LOGO LABEL PD120
8	52.82V11G001	FRONT COVER SPONGE PD120
9	51.82V22G001	MYLAR LIGHT CUT PD120

Note: Please refer to RSPL for updated Part Number.

PD120 Assy Blower Fan Module

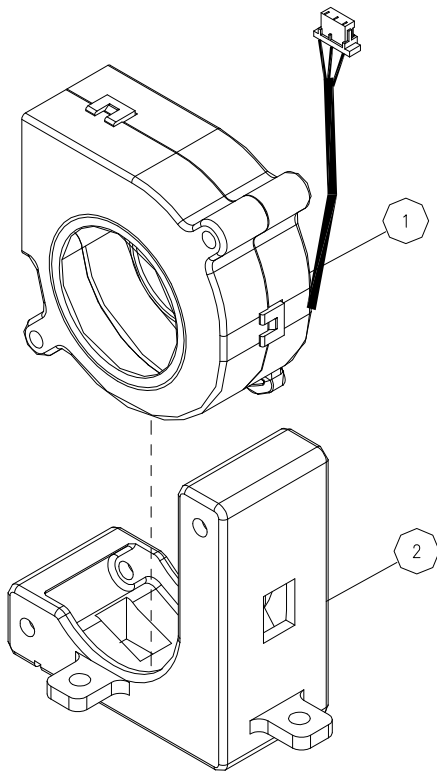

Exploded Parts List

Item	Part Number	Description
1	49.83A01G001	DELTA 4520 BLOW
2	52.82G08G001	BLOWER 4520 RUBBER EP7190

Note: Please refer to RSPL for updated Part Number.

PD120 Assy Engine Bottom Cover Module

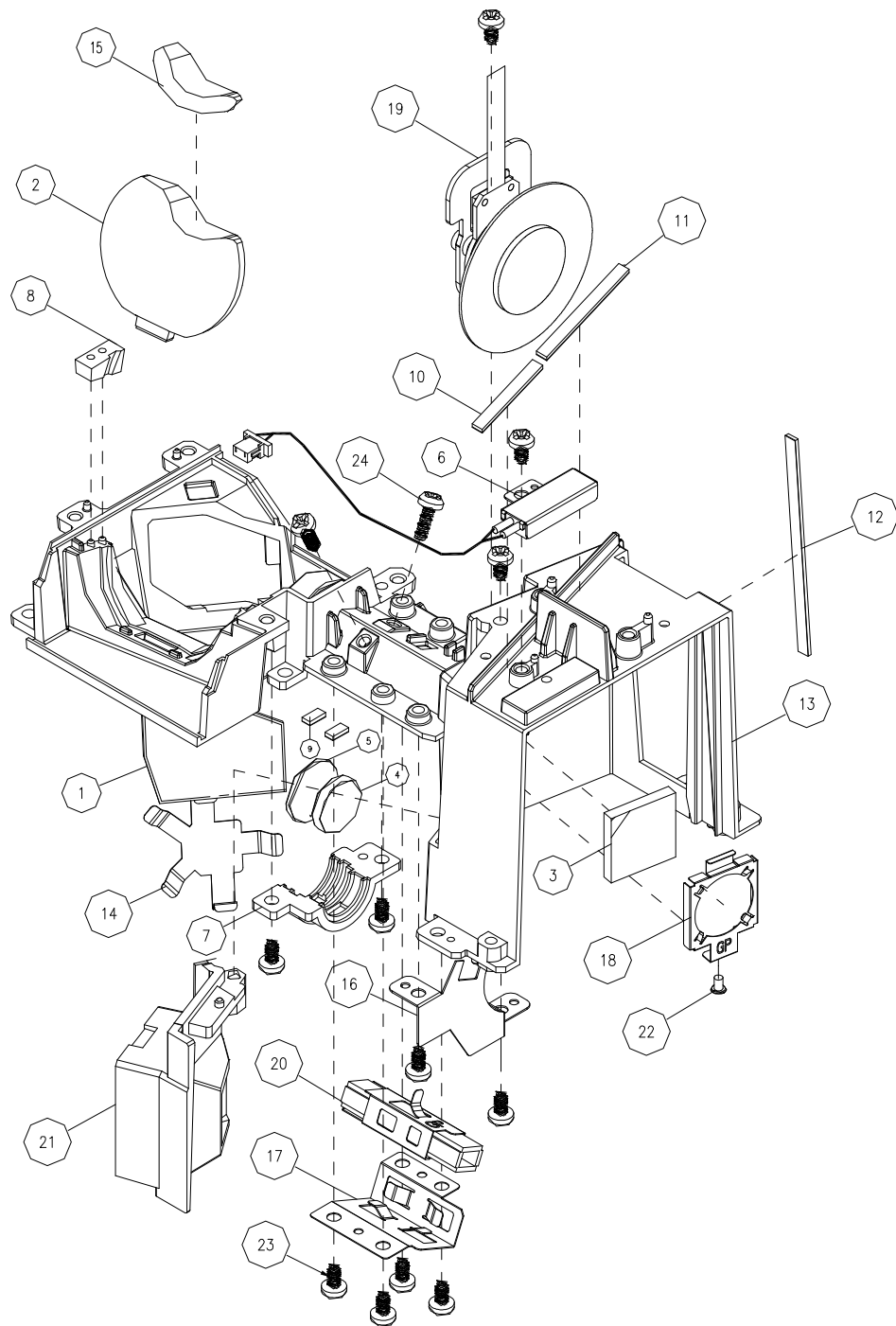

Exploded Parts List

Item	Part Number	Description
1	23.82G02G001	MIRROR WITH ONE COATING SURFACE
2	23.82G06G001	ASPHERICAL ZEONEX RELAY LENS
3	23.82G10G001	SQUARE UV-IR 17*17mm ² T=2.75mm
4	23.82G20G001	BK7 CONDENSER LENS p13.00mm
5	23.82G20G011	BK7 CONDENSER LENS p15.00mm
6	43.80N01G001	THERMAL SWITCH 120J TI , YS11A120B-026, WHITE JST CONNECTOR,
7	51.82G13G001	CONDENSER HOLDER PC+20%GF EP7190 'GREEN'
8	52.82G04G002	RELAY SIDE SEALED RUBBER-2 EP719
9	52.82G09G001	CONDENSER CUSHION RUBBER EP7190
10	52.82G12G001	FAN HOLDER SEALED-1 HT800 EP719
11	52.82G13G001	FAN HOLDER SEALED-2 HT800 EP719
12	52.82G14G001	FAN HOLDER SEALED-3 HT800 EP719
13	61.82G03G001	ENGINE BOTTOM COVER Mg ALLOY AZ91D EP7190
14	61.82G11G001	MIRROR HOLDER PLATE SUS301 0.25t EP7190
15	51.82G25G001	RELAY LENS MYLAR EP719
16	61.82G19G001	ROD HIDE RAY PLATE AL 0.4t EP7190
17	61.82G21G001	ROD FIX PLATE SUS301 0.25t EP7190
18	61.82G22G001	UV-IR GLASS HOLDER SUS301 0.2t EP7190
19	70.82G15G001	ASSY COLOR WHEEL MODULE EP7190
20	70.83S05G001	ASSY ROD MODULE PJ406D
21	75.82G08G001	BUY ASSY 50*25 BLOWER FAN DUCT AL EP719
22	85.0A122G030	SCREW DOUBLE FLAT MECH M2*3Ni
23	85.1A123.050	SCREW PAN MECH M3*5 Ni
24	85.1A523G080	SCREW PAN MECH M3*8 Ni NYLOK

Note: Please refer to RSPL for updated Part Number.

PD120 Assy Lens Cap Module

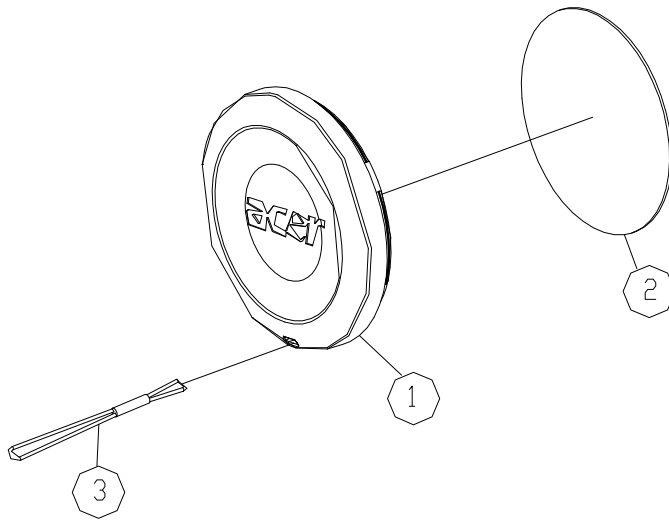

Exploded Parts List

Item	Part Number	Description
1	52.82V01G001	LENS COVER RUBBER PD120
2	61.82V08G001	LENS COVER PLATE PD120
3	51.83150G001	CAP STRAP TDP-T90

Note: Please refer to RSPL for updated Part Number.

PD120 Assy LVPS Module

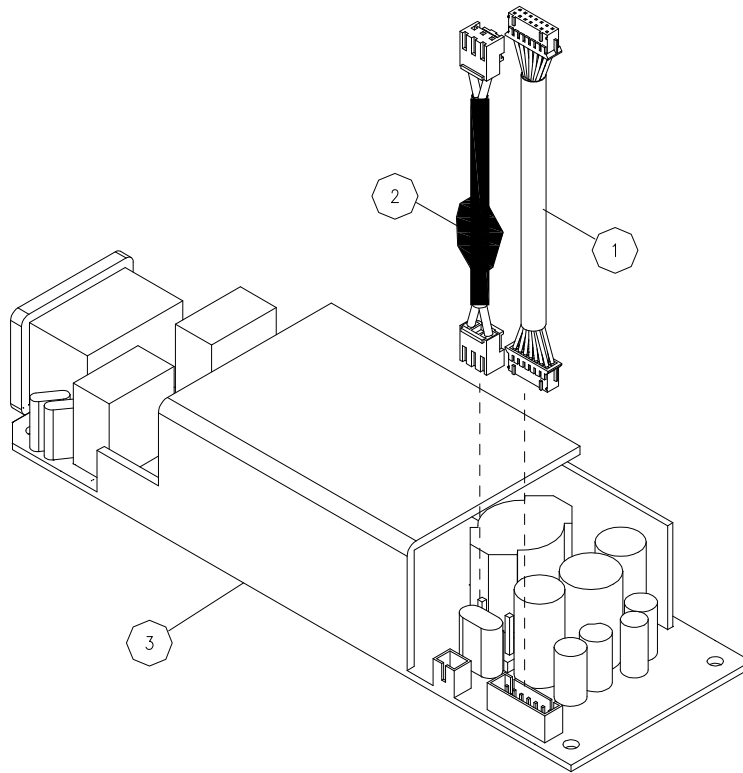

Exploded Parts List

Item	Part Number	Description
1	42.80S07G001	W.A. 14P 190mm LVPS TO M/B TDP-T90 "
2	42.81G01.001	W.A. 2P #20 160mm LAPS/BALLAST H31
3	75.80W19G001	ASSY LVPS LITEON 200W 2300MP

Note: Please refer to RSPL for updated Part Number.

PD100 Assy Lamp Cover Module

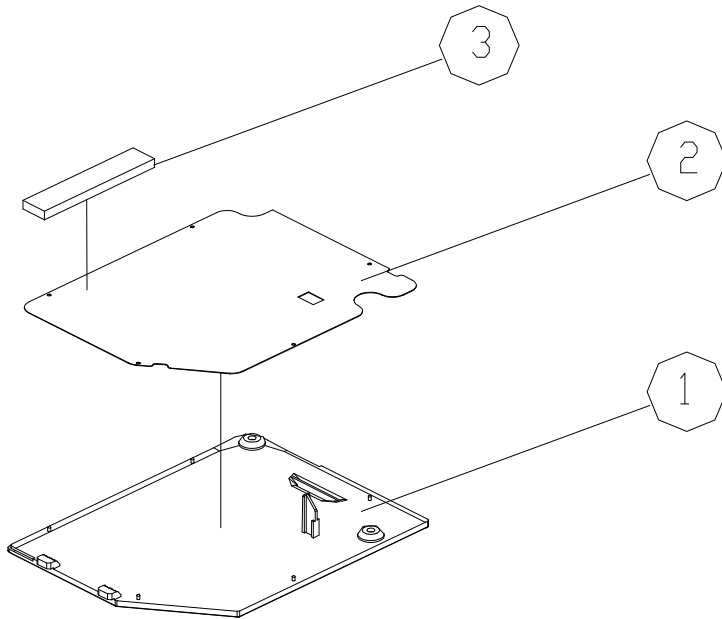

Exploded Parts List

Item	Part Number	Description
1	51.82V13G002	LAMP COVER NORYL 9406P PD100
2	61.82V09G001	LAMP COVER PLATE SPTTE PD120
3	52.82V08G001	LAMP COVER SPONGE PD120

Note: Please refer to RSPL for updated Part Number.

PD120 Assy Lamp Cover Module

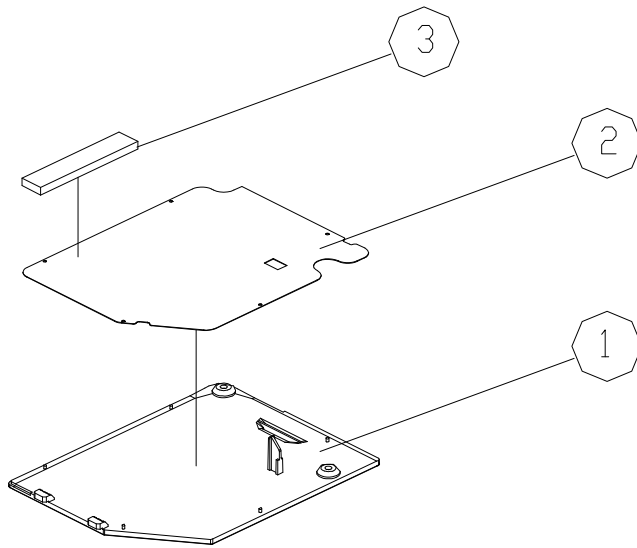

Exploded Parts List

Item	Part Number	Description
1	51.82V13G001	LAMP COVER NORYL 9406P PD120
2	61.82V09G001	LAMP COVER PLATE SPTe PD120
3	52.82V08G001	LAMP COVER SPONGE PD120

Note: Please refer to RSPL for updated Part Number.

PD120 Assy Elevator Module

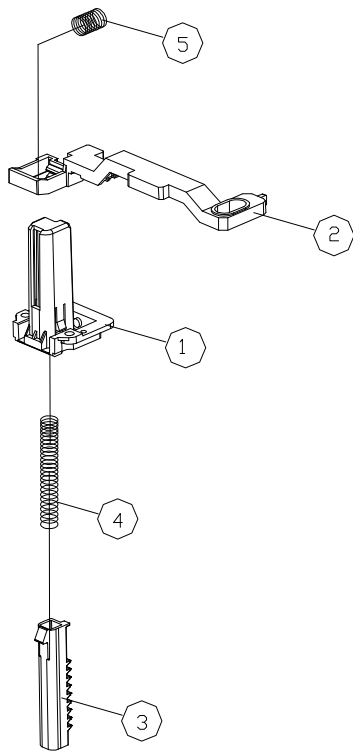

Exploded Parts List

Item	Part Number	Description
1	51.82V06G001	ELEVATOR HOLDER PC+ABS PD120
2	51.82V07G001	ELEVATOR PUSH PC+ABS PD120
3	51.86809.001	ELEVATOR BODY NYLON+GF DP725
4	61.86814.001	ELEVATOR EXTEND SPRING DP725
5	61.85913.001	ELEVATOR SPRING SUS304 SB21

Note: Please refer to RSPL for updated Part Number.

Serial Number Definition System

I. Serial Number System Definition

Serial No. (Acer Barcode rule), 22 digits

(Barcode Type: Code 128)



The coding rule of the Bard Code:

(1) P P P P P P P P P P (10 digitals) : Part Number excluded "dot"

Ex: EY.J1401.001.

(2) W W W (3 digitals) : Week Code

The first digit is the last letter of the year; the other two letters are the number of the weeks.

Ex: Year 2001 10th weeks => 110.

(3) S S S S S (5 digitals) : Serial Numbers

From 00001 to FFFFF by hexadecimal 0~9, A, B, C, D, E, F, weekly reset the number
Started from "00001".

(4) M M (2 digitals) : Manufacturing Code

Manufacturing Code will be applied by different manufacturing site.

Coretronic : PP / RU / RM (3 different sites)

(5) E E (2 digitals) : Eng. Version Code

If it doesn't have version control, it will be put with zero "00"

II. PCBA Code Definition

PCBA Code for Projector

A B XXXXXXXXXX C XXX EEEE
① ② ③ ④ ⑤ ⑥

- ① : ID C: M/B
B: DMD/ B
- ② : Vendor Code
- ③ : P/N
- ④ : Revision
- ⑤ : Date Code
- ⑥ : S/N

III. The Different Parts between PD100 and PD120

PN	Ver.	Description	PD100	PD120
48.859DMGD13	A	DMD 800*600 PIXEL DDR FTP 0.55	V	
48.82GDMGD01	A	DMD 1024*768 PIXEL DDR FTP 0.5		V
51.82V02G002	A	BOTTOM COVER PC+ABS PD100	V	
51.82V02G001	A	BOTTOM COVER PC+ABS PD120		V
80.82V51G001	D	PCBA MAIN BD PD100	V	
80.82V01G001	D	PCBA MAIN BD PD120		V
35.82V01G002	A	MODEL NAME LABEL PC PD100	V	
35.82V01G001	A	MODEL NAME LABEL PC PD120		V
51.82V01G002	A	FRONT COVER NORYL 9406P PD100	V	
51.82V01G001	A	FRONT COVER NORYL 9406P PD120		V
51.82V08G002	A	FRONT PUSH BUTTON PC+ABS PD100	V	
51.82V08G001	A	FRONT PUSH BUTTON PC+ABS PD120		V
51.82V04G012	A	BACK COVER-DC PC+ABS PD100	V	
51.82V04G011	A	BACK COVER-DC PC+ABS PD120		V
51.82V03G002	A	TOP COVER PC+ABS PD100	V	
51.82V03G001	A	TOP COVER PC+ABS PD120		V
51.82V13G002	A	LAMP COVER NORYL 9406P PD100	V	
51.82V13G001	A	LAMP COVER NORYL 9406P PD120		V

Free Manuals Download Website

<http://myh66.com>

<http://usermanuals.us>

<http://www.somanuals.com>

<http://www.4manuals.cc>

<http://www.manual-lib.com>

<http://www.404manual.com>

<http://www.luxmanual.com>

<http://aubethermostatmanual.com>

Golf course search by state

<http://golfingnear.com>

Email search by domain

<http://emailbydomain.com>

Auto manuals search

<http://auto.somanuals.com>

TV manuals search

<http://tv.somanuals.com>