

Acer ProDock

User Guide

© 2011 All Rights Reserved.

Acer ProDock User Guide
Original Issue: 05/2011

Model number: _____

Serial number: _____

Date of purchase: _____

Place of purchase: _____

Information for your safety and comfort

Safety instructions

Read these instructions carefully. Keep this document for future reference. Follow all warnings and instructions marked on the product.

Turning the product off before cleaning

Unplug this product from the wall outlet before cleaning. Do not use liquid cleaners or aerosol cleaners. Use a damp cloth for cleaning.

Warnings

Accessing the power cord

Be sure that the power outlet you plug the power cord into is easily accessible and located as close to the equipment operator as possible. When you need to disconnect power to the equipment, be sure to unplug the power cord from the electrical outlet.

Disconnecting the power source

Observe the following guidelines when connecting and disconnecting power to the power supply unit:

Install the power supply unit before connecting the power cord to the AC power outlet.

If the system has multiple sources of power, disconnect power from the system by unplugging all power cords from the power supplies.

Using electrical power

- This product should be operated from the type of power indicated on the marking label. If you are not sure of the type of power available, consult your dealer or local power company.
- Do not allow anything to rest on the power cord. Do not locate this product where people will walk on the cord.
- If an extension cord is used with this product, make sure that the total ampere rating of the equipment plugged into the extension cord does not exceed the extension cord ampere rating. Also, make sure that the total rating of all products plugged into the wall outlet does not exceed the fuse rating.

- Do not overload a power outlet, strip or receptacle by plugging in too many devices. The overall system load must not exceed 80% of the branch circuit rating. If power strips are used, the load should not exceed 80% of the power strip's input rating.
- This product's AC adapter is equipped with a three-wire grounded plug. The plug only fits in a grounded power outlet. Make sure the power outlet is properly grounded before inserting the AC adapter plug. Do not insert the plug into a non-grounded power outlet. Contact your electrician for details.



.....

Warning! The grounding pin is a safety feature. Using a power outlet that is not properly grounded may result in electric shock and/or injury.



.....

Note: The grounding pin also provides good protection from unexpected noise produced by other nearby electrical devices that may interfere with the performance of this product.

- The system can be powered using a wide range of voltages; 100 to 120 or 220 to 240 V AC. The power cord included with the system meets the requirements for use in the country/region where the system was purchased. Power cords for use in other countries/regions must meet the requirements for that country/region. For more information on power cord requirements, contact an authorized reseller or service provider.

Protecting your hearing



.....

Warning: Permanent hearing loss may occur if earphones or headphones are used at high volume for prolonged periods of time.



To protect your hearing, follow these instructions.

- Increase the volume gradually until you can hear clearly and comfortably.
- Do not increase the volume level after your ears have adjusted.
- Do not listen to music at high volumes for extended periods.
- Do not increase the volume to block out noisy surroundings.
- Decrease the volume if you can't hear people speaking near you.

General

- Do not use this product near water.
- Do not place this product on an unstable cart, stand or table. If the product

falls, it could be seriously damaged.

- Slots and openings are provided for ventilation to ensure reliable operation of the product and to protect it from overheating. These openings must not be blocked or covered. The openings should never be blocked by placing the product on a bed, sofa, rug or other similar surface. This product should never be placed near or over a radiator or heat register, or in a built-in installation unless proper ventilation is provided.
- Never push objects of any kind into this product through cabinet slots as they may touch dangerous voltage points or short-out parts that could result in a fire or electric shock. Never spill liquid of any kind onto or into the product.
- To avoid damage of internal components and to prevent battery leakage, do not place the product on a vibrating surface.
- Never use it under sporting, exercising, or any vibrating environment which will probably cause unexpected short current or damage rotor devices, HDD, Optical drive, and even exposure risk from lithium battery pack.
- The bottom surface, areas around ventilation openings and AC adapter may get hot. To avoid injury, ensure they do not come in contact with your skin or body.
- Your device and its enhancements may contain small parts. Keep them out of the reach of small children.

Product servicing

Do not attempt to service this product yourself, as opening or removing covers may expose you to dangerous voltage points or other risks. Refer all servicing to qualified service personnel.

Unplug this product from the wall outlet and refer servicing to qualified service personnel when:

- The power cord or plug is damaged, cut or frayed.
- Liquid was spilled into the product.
- The product was exposed to rain or water.
- The product has been dropped or the case has been damaged.
- The product exhibits a distinct change in performance, indicating a need for service.
- The product does not operate normally after following the operating instructions.



.....
Note: Adjust only those controls that are covered by the operating instructions, since improper adjustment of other controls may

result in damage and will often require extensive work by a qualified technician to restore the product to normal condition.

Disposal instructions

Do not throw this electronic device into the trash when discarding. To minimize pollution and ensure utmost protection of the global environment, please recycle. For more information on the Waste from Electrical and Electronics Equipment (WEEE) regulations, visit www.acer-group.com/public/Sustainability/sustainability01.htm



Tips and information for comfortable use

Computer users may complain of eyestrain and headaches after prolonged use. Users are also at risk of physical injury after long hours of working in front of a computer. Long work periods, bad posture, poor work habits, stress, inadequate working conditions, personal health and other factors greatly increase the risk of physical injury.

Incorrect computer usage may lead to carpal tunnel syndrome, tendonitis, tenosynovitis or other musculoskeletal disorders. The following symptoms may appear in the hands, wrists, arms, shoulders, neck or back:

- Numbness, or a burning or tingling sensation.
- Aching, soreness or tenderness.
- Pain, swelling or throbbing.
- Stiffness or tightness.
- Coldness or weakness.

If you have these symptoms, or any other recurring or persistent discomfort and/or pain related to computer use, consult a physician immediately and inform your company's health and safety department.

The following section provides tips for more comfortable computer use.

Finding your comfort zone

Find your comfort zone by adjusting the viewing angle of the monitor, using a footrest, or raising your sitting height to achieve maximum comfort. Observe the following tips:

- Refrain from staying too long in one fixed posture.
- Avoid slouching forward and/or leaning backward.
- Stand up and walk around regularly to remove the strain on your leg muscles.
- Take short rests to relax your neck and shoulders.
- Avoid tensing your muscles or shrugging your shoulders.
- Install the external display, keyboard and mouse properly and within

comfortable reach.

- If you view your monitor more than your documents, place the display at the center of your desk to minimize neck strain.

Taking care of your vision

Long viewing hours, wearing incorrect glasses or contact lenses, glare, excessive room lighting, poorly focused screens, very small typefaces and low-contrast displays could stress your eyes. The following sections provide suggestions on how to reduce eyestrain.

Eyes

- Rest your eyes frequently.
- Give your eyes regular breaks by looking away from the monitor and focusing on a distant point.
- Blink frequently to keep your eyes from drying out.

Display

- Keep your display clean.
- Keep your head at a higher level than the top edge of the display so your eyes point downward when looking at the middle of the display.
- Adjust the display brightness and/or contrast to a comfortable level for enhanced text readability and graphics clarity.
- Eliminate glare and reflections by:
 - placing your display in such a way that the side faces the window or any light source
 - minimizing room light by using drapes, shades or blinds
 - using a task light
 - changing the display's viewing angle
 - using a glare-reduction filter
 - using a display visor, such as a piece of cardboard extended from the display's top front edge
- Avoid adjusting your display to an awkward viewing angle.
- Avoid looking at bright light sources for extended periods of time.

Developing good work habits

The following work habits make computer use more relaxing and productive:

- Take short breaks regularly and often.
- Perform some stretching exercises.
- Breathe fresh air as often as possible.
- Exercise regularly and maintain a healthy body.



Warning! We do not recommend using the computer on a couch or bed. If this is unavoidable, work for only short periods, take breaks regularly, and do some stretching exercises.



Note: For more information, please refer to "**Regulations and safety notices**" on page 15.

First Things first

We would like to thank you for making the Acer ProDock your choice. This User Guide will introduce you to the various features your new docking station has, and provides clear and concise information about the product, so please read it thoroughly and retain it for future reference.

Now that you have unpacked your ProDock, you may wish to familiarize yourself with the ports and connectors, and their locations. For information on which ports are active when a notebook is connected to ProDock, please refer to "**Notes on port functionality**" on page 12.

Top and left views

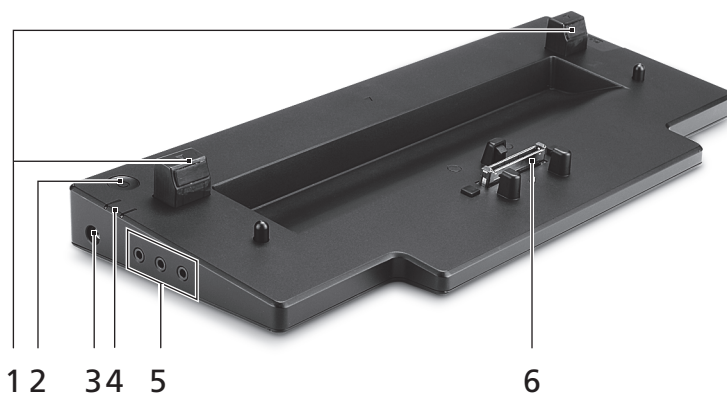

#	Item	Description
1	Notebook rests	Ensure your notebook is correctly positioned for connecting to the ProDock.
2	Power button	
3	DC-in jack	Connects to the AC adapter to power the ProDock and attached notebook. Note: The power adapter needs to be a 90 W or higher adapter.

#	Item	Description
4	Power indicator	Indicates the system's power status. 1. Off: No AC adapter plugged in. 2. Orange: AC adapter connected; notebook in a power-saving mode. 3. Green: AC adapter connected; notebook is turned on.
	Docking indicator	Indicates if a notebook is docked. 1. Off: Notebook is not docked. 2. Green: Notebook is docked.
5	Microphone jack ⁶	Accepts audio input from external microphones.
	Headphone/speaker jack ⁶	Connects to audio devices (e.g., speakers, headphones).
	Line-in jack ⁶	Accepts audio input from line-in devices.
6	144-pin connector	Connects to compatible notebooks.

Base view

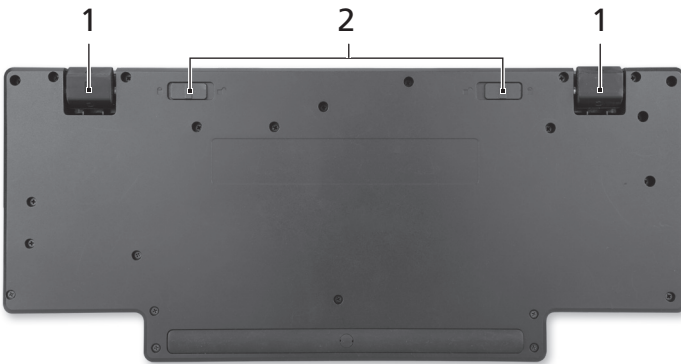

#	Item	Description
1	Rotating feet	Adjust the ProDock angle for different computers.
2	Foot locks	Secure the feet in the correct orientation.

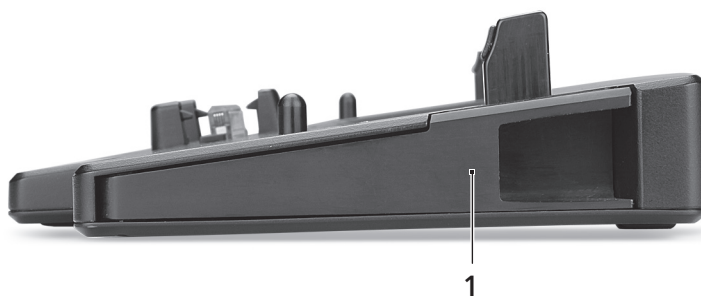

Right view



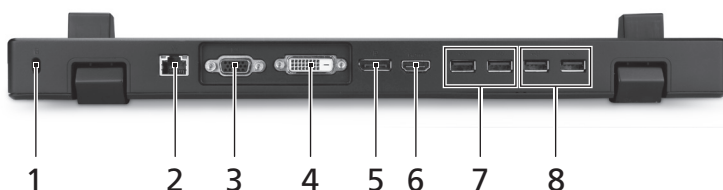

#	Icon	Item	Description
1		Release lever	Releases the notebook from the ProDock.

Rear view



#	Icon	Item	Description
1		Kensington lock slot	Connects to a Kensington-compatible computer security lock. Note: Wrap the security lock cable around an immovable object such as a table or handle of a locked drawer. Insert the lock into the notch and turn the key to secure the lock. Some keyless models are also available.
2		Ethernet (RJ-45) port ¹	Connects to an Ethernet 10/100/1000-based network.
3		External display (VGA) port ⁴	Connects to a display device (e.g., external monitor, LCD projector).

#	Icon	Item	Description
4		DVI port ^{1, 4, 5}	Supports high-definition digital video connections.
5		DisplayPort ^{1, 5}	Supports high-definition digital video connections.
6		HDMI port ^{1, 4, 5}	Supports high-definition digital video connections.
7		USB 3.0 ports ^{1, 2}	Connect to USB devices. USB 3.0 ports can be distinguished by the blue connector.
8		USB 3.0 ports with USB charging function ^{1, 2, 3}	Connect to USB devices. USB 3.0 ports can be distinguished by the blue connector.

Information on USB 3.0

- Defined by the USB 3.0 (SuperSpeed USB) specification.
- Devices without USB 3.0 certification may not be compatible.

Notes on port functionality

- 1 Acer ProDock port functionality will follow the standard supported by the attached device.
- 2 Ports are enabled on the Acer ProDock and the notebook, and can be used concurrently.
- 3 Support USB charging when the notebook is turned off.
- 4 Ports are enabled only on Acer ProDock; they are disabled on the notebook.
- 5 Acer ProDock supports multiple monitors; however, the HDMI and DVI ports cannot be used at the same time.
- 6 Ports on both the Acer ProDock and notebook are enabled, but only one set of ports can be used at any time.

Using ProDock

ProDock allows you to set up your desk so you can use your notebook with an external keyboard and mouse, and up to three monitors. Yet you can quickly and easily disconnect your notebook and take it to a meeting with you.

You can also charge your notebook's battery through ProDock

Connecting a notebook to ProDock

- 1 Turn off your notebook and disconnect the power adapter.



.....
Warning: Failing to disconnect the adapter may result in damage to the adapter and/or notebook when you connect it to ProDock.

- 2 Refer to the underside of your notebook, next to the ProDock connector, you should see a sticker with the letter A, B, or C on it.
- 3 Turn the ProDock upside-down and unlock the feet. Rotate the feet to show the letter corresponding to the letter under your notebook. Slide the locks back to secure the feet.
- 4 Place the ProDock upright on a flat surface.
- 5 Position your Acer notebook against the stops at the back of the ProDock and gently push it down until you hear it click in place.

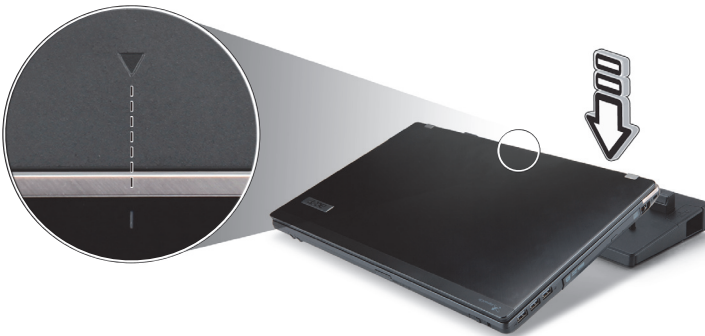

.....
Tip: Align the mark on the back of the notebook with the arrow on ProDock to ensure easy connection.

Disconnecting the notebook

To disconnect your notebook from ProDock, simply pull on the release lever on the right-hand side of ProDock. This will release the lock and push your notebook up a bit.

Carefully lift your notebook off ProDock.



Regulations and safety notices

FCC statement

This device has been tested and found to comply with the limits for a Class B digital device pursuant to Part 15 of the FCC rules. These limits are designed to provide reasonable protection against harmful interference in a residential installation. This device generates, uses, and can radiate radio frequency energy and, if not installed and used in accordance with the instructions, may cause harmful interference to radio communications.

However, there is no guarantee that interference will not occur in a particular installation. If this device does cause harmful interference to radio or television reception, which can be determined by turning the device off and on, the user is encouraged to try to correct the interference by one or more of the following measures:

- Reorient or relocate the receiving antenna.
- Increase the separation between the device and receiver.
- Connect the device into an outlet on a circuit different from that to which the receiver is connected.
- Consult the dealer or an experienced radio/television technician for help.

Notice: Shielded cables

All connections to other computing devices must be made using shielded cables to maintain compliance with FCC regulations.

Notice: Peripheral devices

Only peripherals (input/output devices, terminals, printers, etc.) certified to comply with the Class B limits may be attached to this equipment. Operation with non-certified peripherals is likely to result in interference to radio and TV reception.

Caution

Changes or modifications not expressly approved by the manufacturer could void the user's authority, which is granted by the Federal Communications Commission, to operate this computer.

Notice: Canadian users

This Class B digital apparatus complies with Canadian ICES-003.

Remarque à l'intention des utilisateurs canadiens

Cet appareil numérique de la classe B est conforme à la norme NMB-003 du Canada.

Compliant with Russian regulatory certification



Declaration of Conformity for EU countries

Hereby, Acer, declares that this computer is in compliance with the essential requirements and other relevant provisions of Directive 1999/5/EC.

List of National Codes

This equipment may be operated in the following countries:

Country	ISO 3166 2 letter code	Country	ISO 3166 2 letter code
Austria	AT	Malta	MT
Belgium	BE	Netherlands	NT
Cyprus	CY	Poland	PL
Czech Republic	CZ	Portugal	PT
Denmark	DK	Slovakia	SK
Estonia	EE	Slovenia	SL
Finland	FI	Spain	ES
France	FR	Sweden	SE
Germany	DE	United Kingdom	GB
Greece	GR	Iceland	IS
Hungary	HU	Liechtenstein	LI
Ireland	IE	Norway	NO
Italy	IT	Switzerland	CH
Latvia	LV	Bulgaria	BG
Lithuania	LT	Romania	RO
Luxembourg	LU	Turkey	TR

Operating environment information

- Temperature:
 - Operating: 5 °C to 35 °C
 - Non-operating: -20 °C to 65 °C
 - Humidity (non-condensing):
 - Operating: 20% to 80%
 - Non-operating: 20% to 80%
-

Free Manuals Download Website

<http://myh66.com>

<http://usermanuals.us>

<http://www.somanuals.com>

<http://www.4manuals.cc>

<http://www.manual-lib.com>

<http://www.404manual.com>

<http://www.luxmanual.com>

<http://aubethermostatmanual.com>

Golf course search by state

<http://golfingnear.com>

Email search by domain

<http://emailbydomain.com>

Auto manuals search

<http://auto.somanuals.com>

TV manuals search

<http://tv.somanuals.com>