

LIFECYCLE EXTENSION GUIDE



Contents

Table of Contents

Important Safety Notice-----	3
1. Exploded Diagram -----	4
2. Wiring connectivity diagram-----	5
3. Mechanical Instructure-----	6
4. Assembly and Disassembly Procedures-----	7
5. Troubleshooting-----	15
6. FRU List-----	19

Safety Notice

Any person attempting to service this chassis must familiarize with the chassis and be aware of the necessary safety precautions to be used when serving electronic equipment containing high voltage



Important Safety Notice

Product Announcement:

This product is certificated to meet RoHS Directive and Lead-Free produced definition. Using approved critical components only is recommended when the situation to replace defective parts. Vender assumes no liability express or implied, arising out of any unauthorized modification of design or replacing non-RoHS parts. Service providers assume all liability.

Qualified Repairability:

Proper service and repair is important to the safe, reliable operation of all series products. The service providers recommended by vender should being aware of notices listed in this service manual in order to minimize the risk of personal injury when perform service procedures. Furthermore, the possible existed improper repairing method may damage equipment or products. It is recommended that service engineers should have repairing knowledge, experience, as well as appropriate product training per new model before performing the service procedures.

NOTICE:

- ! To avoid electrical shocks, the products should be connect to an authorized power cord, and turn off the master power switch each time before removing the AC power cord.
- ! To prevent the product away from water or exposed in extremely high humidity environment.
- ! To ensure the continued reliability of this product, use only original manufacturer's specified parts.
- ! To ensure following safety repairing behavior, put the replaced part on the components side of PWBA, not solder side.
- ! To ensure using a proper screwdriver, follow the torque and force listed in assembly and disassembly procedures to screw and unscrew screws.
- ! Using Lead-Free solder to well mounted the parts.
- ! The fusion point of Lead-Free solder requested in the degree of 220°C.

1. Exploded Diagram

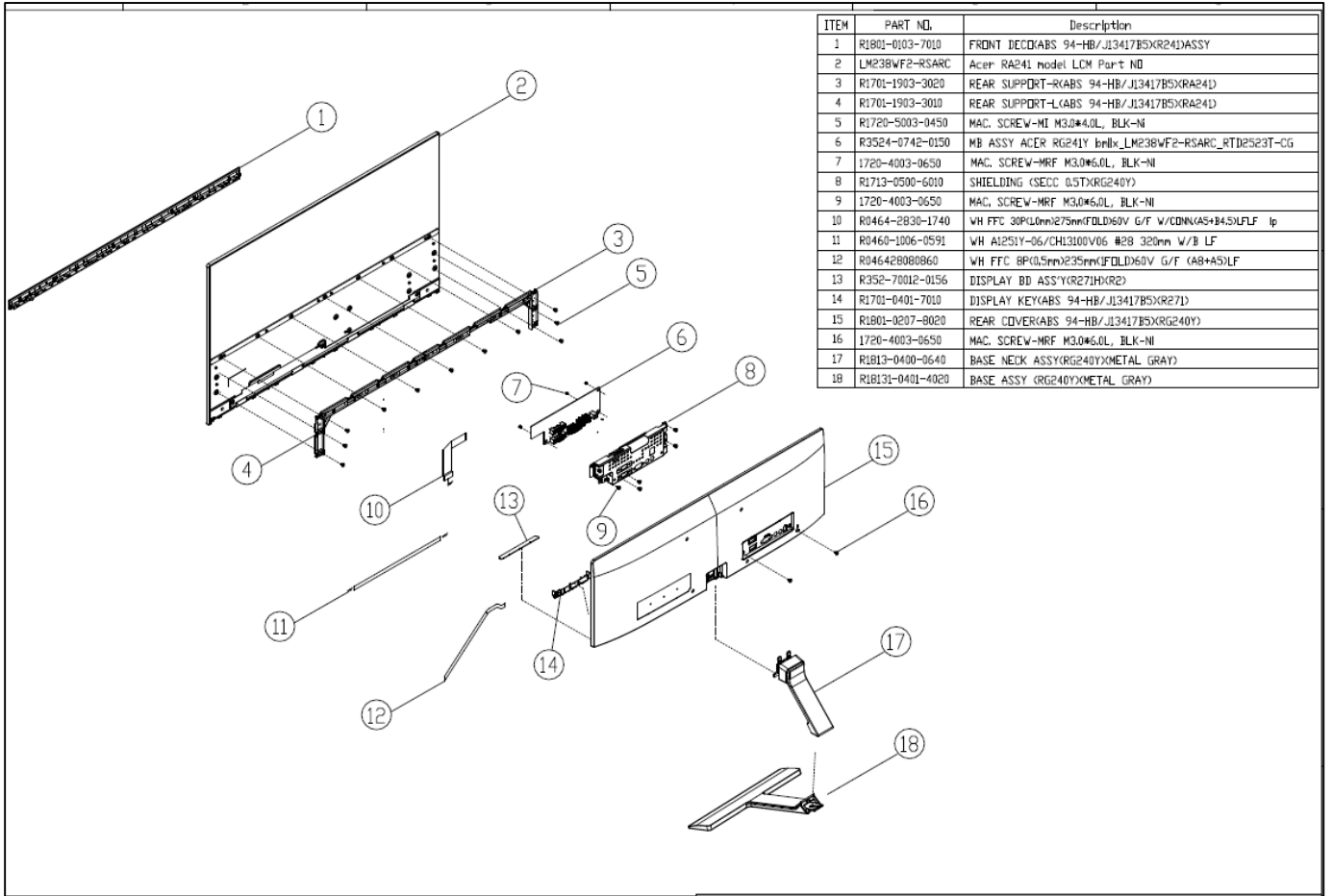

2. Wiring Connectivity diagram

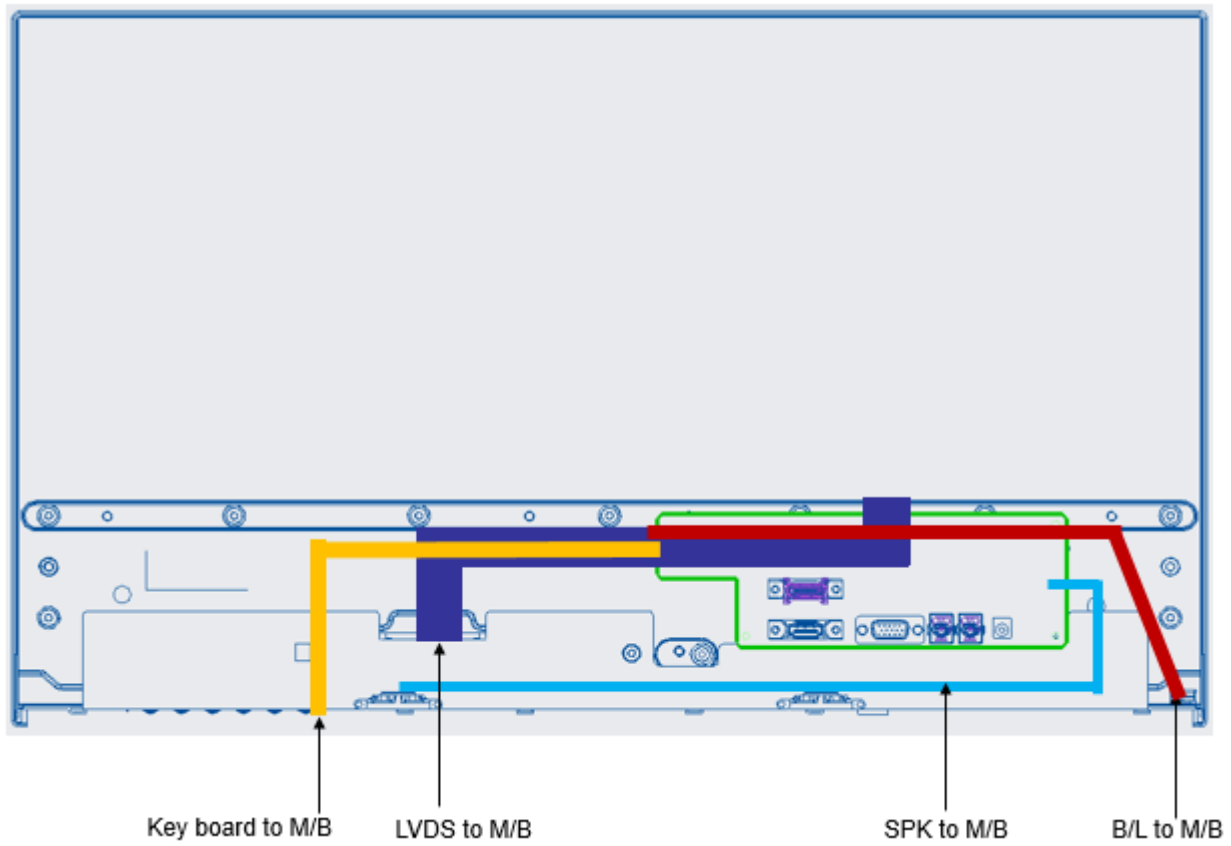

3. Mechanical Instruction

Tools Required

List the type and size of the tools that would typically can be used to disassemble the product to a point where components and materials requiring selective treatment can be removed.

Tool Description:

- working table
- Screw-driver
- Knife
- glove
- cleaning cloth
- ESD protection

4. Assembly and Disassembly Procedures

➤ Disassembly Procedure

Step. 1 Pull the base & stand assembly out



Step.2 Unscrew two screws at the I/O area



Step.3 Disassemble rear cover by a thin plastic tool from a slot at the bottom of rear cover



Step 4. Pull up the rear cover and pull out all connectors

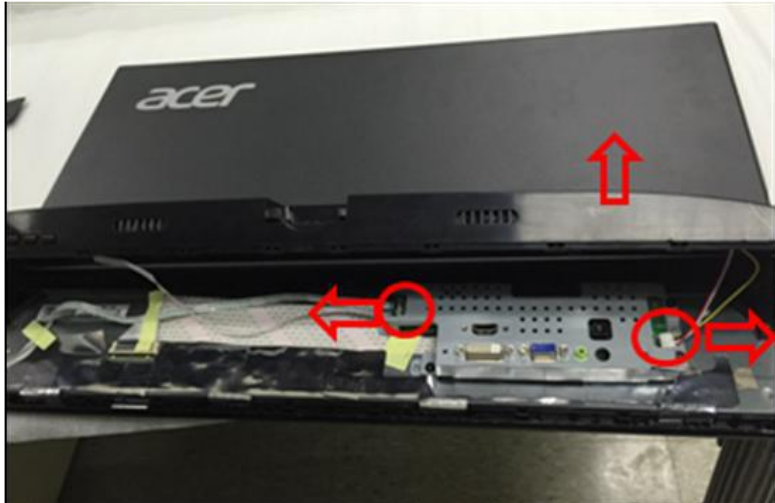

Step.5 Disassemble deco cover.



Step.6 Unscrew PCBA's screws and disassemble frame L&R.



Step.7 Remove F/B and take out the LCM, then separate Key board from F/B and LVDS cable from LCM



Step.8 Remove FFC from display board

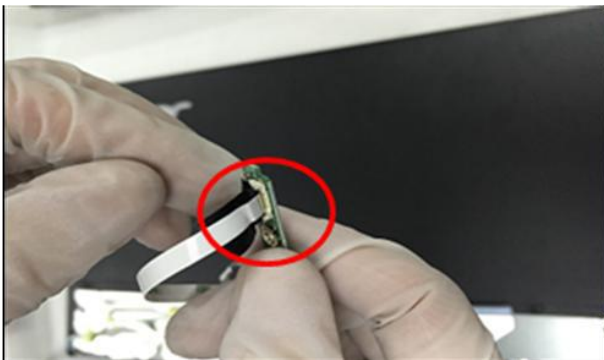

Step.9 Unscrew hex nuts and six screws and remove main board PCBA from main shielding.

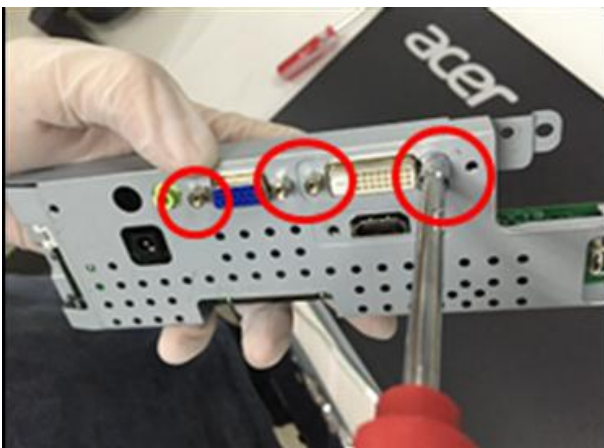



Step.10 Disassemble rear cover assembly

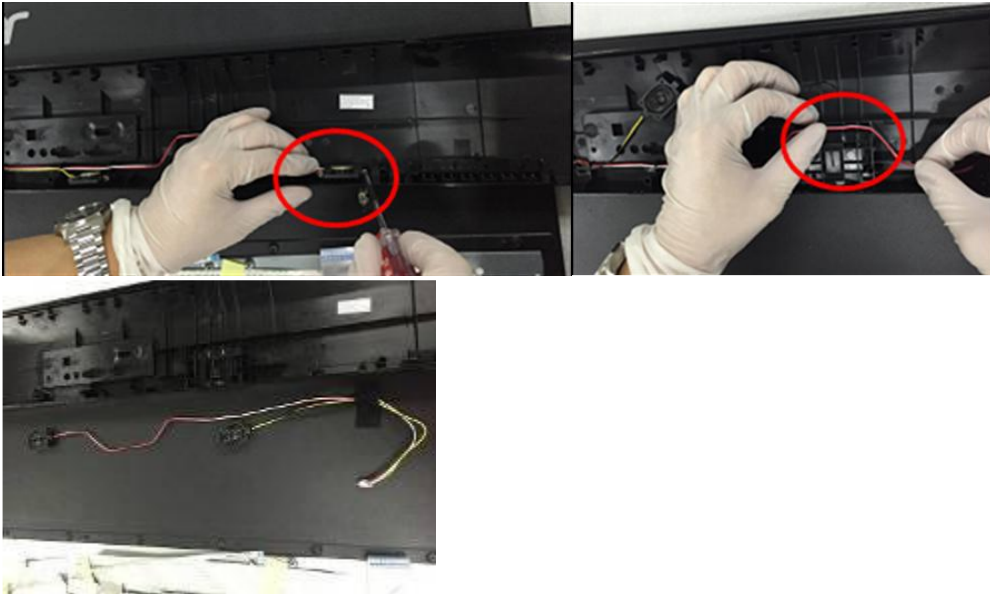

Step11. Unscrew the screw and separate base &neck assembly



Step12. Remove six silicon rubbers



Step.13 Unscrew two screws and separate all small parts



➤ Assembly Procedure

Step1. Assembly 8 FFC to key board

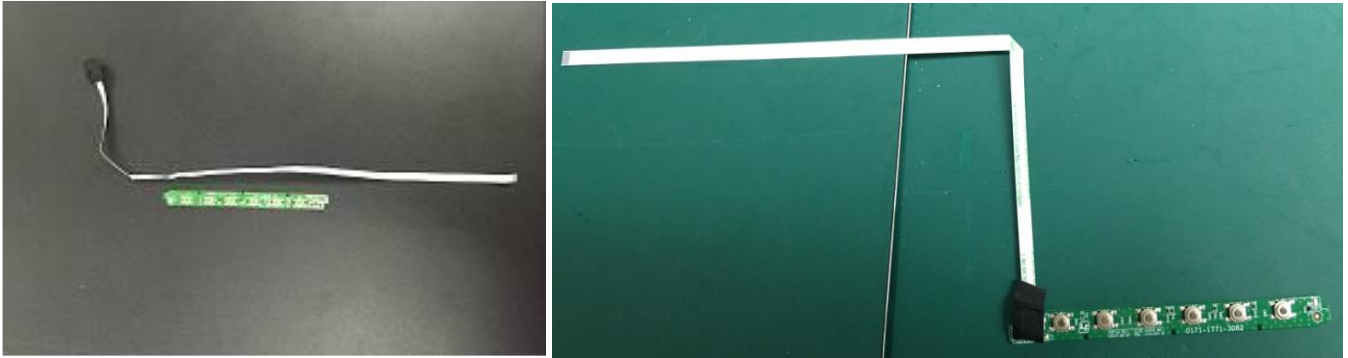

Step2. Assembly key board to rear cover



Step3. Put speaker in rear cover and lock screw to fix

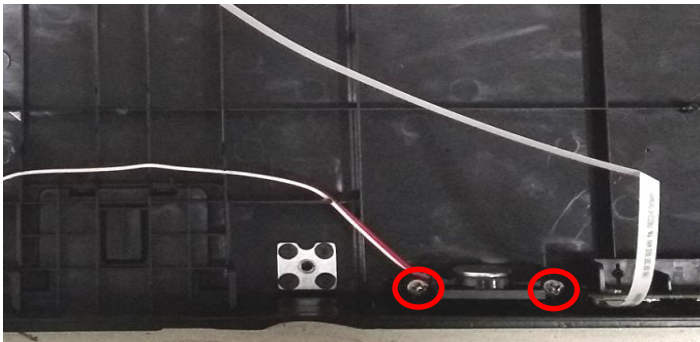

Step4. Assemble frame L&R and lock crews to fix



Step5. Assemble main board into shielding and put MB on panel side



Step5. Insert 30pin LVDS to panel and MB

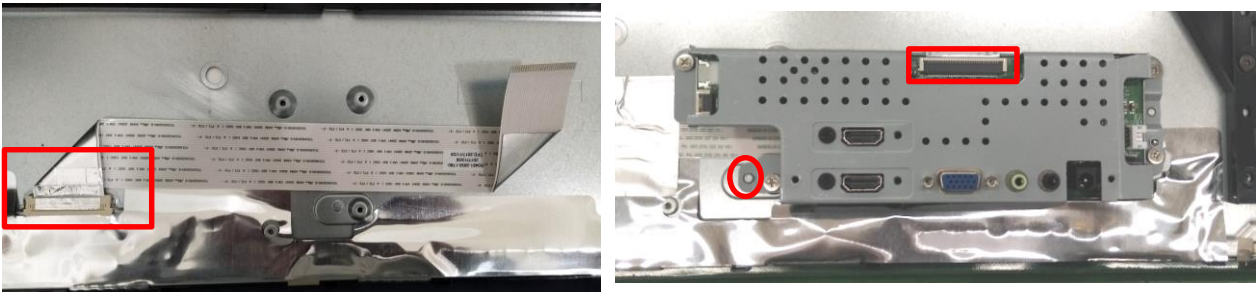

Step6. Lock crews to fix MB and use tape to tape cables

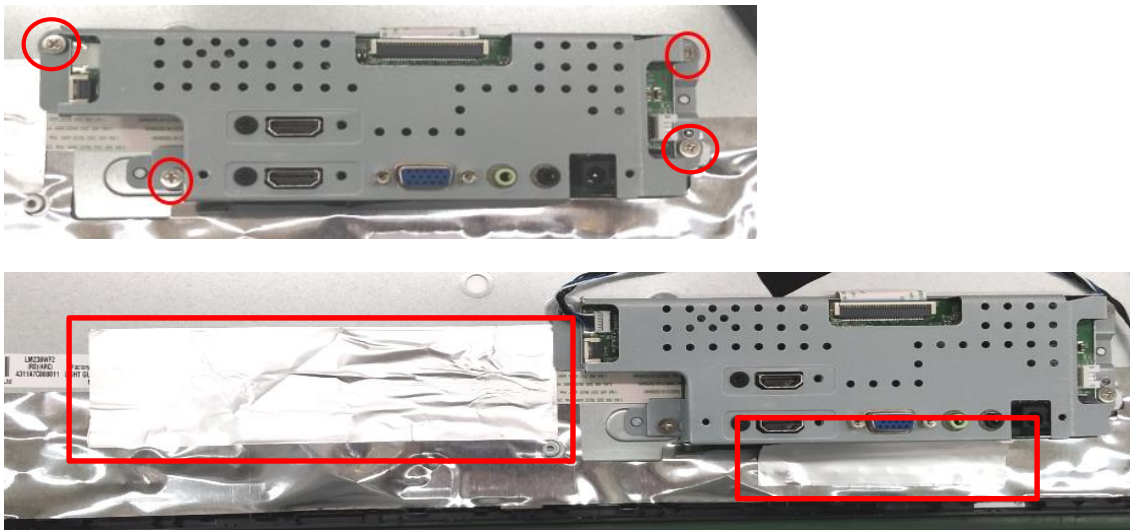

Step7. Insert 6pin cable to panel

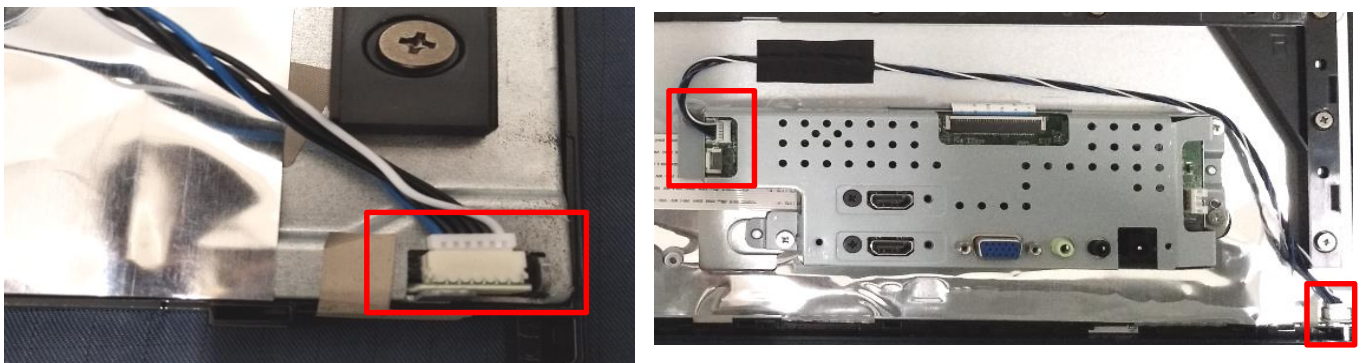

Step8. Assemble deco cover to panel

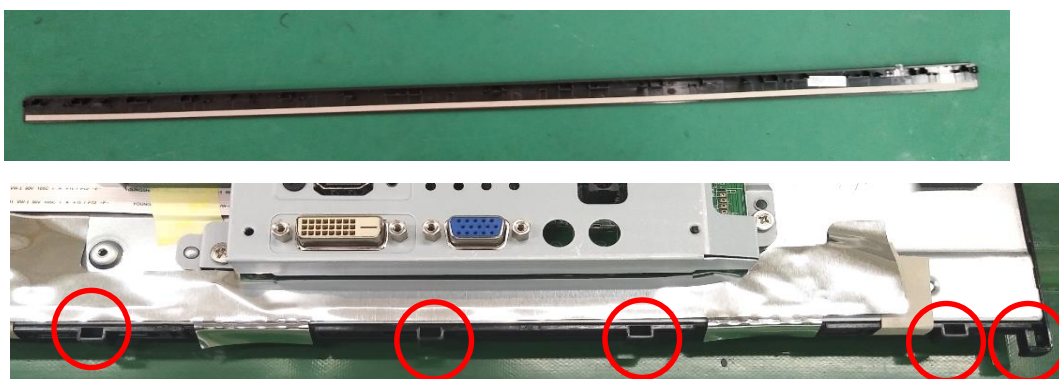

Step9. Insert speaker cable to main board.



Step10. Insert 8pin FFC to MB and assembly rear cover with LCM .

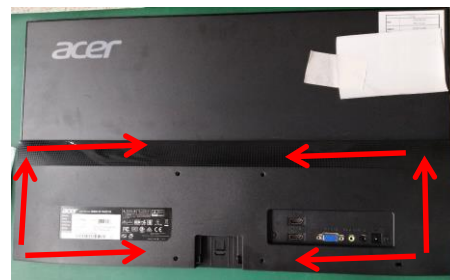
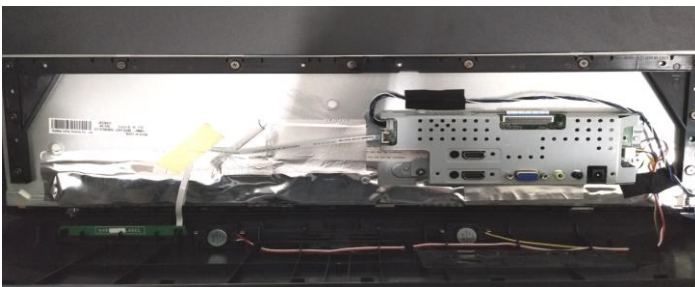

Step11. Lock rear cover screw (in red circle),



5. Troubleshooting

5.1 Test flow for abnormal machine:

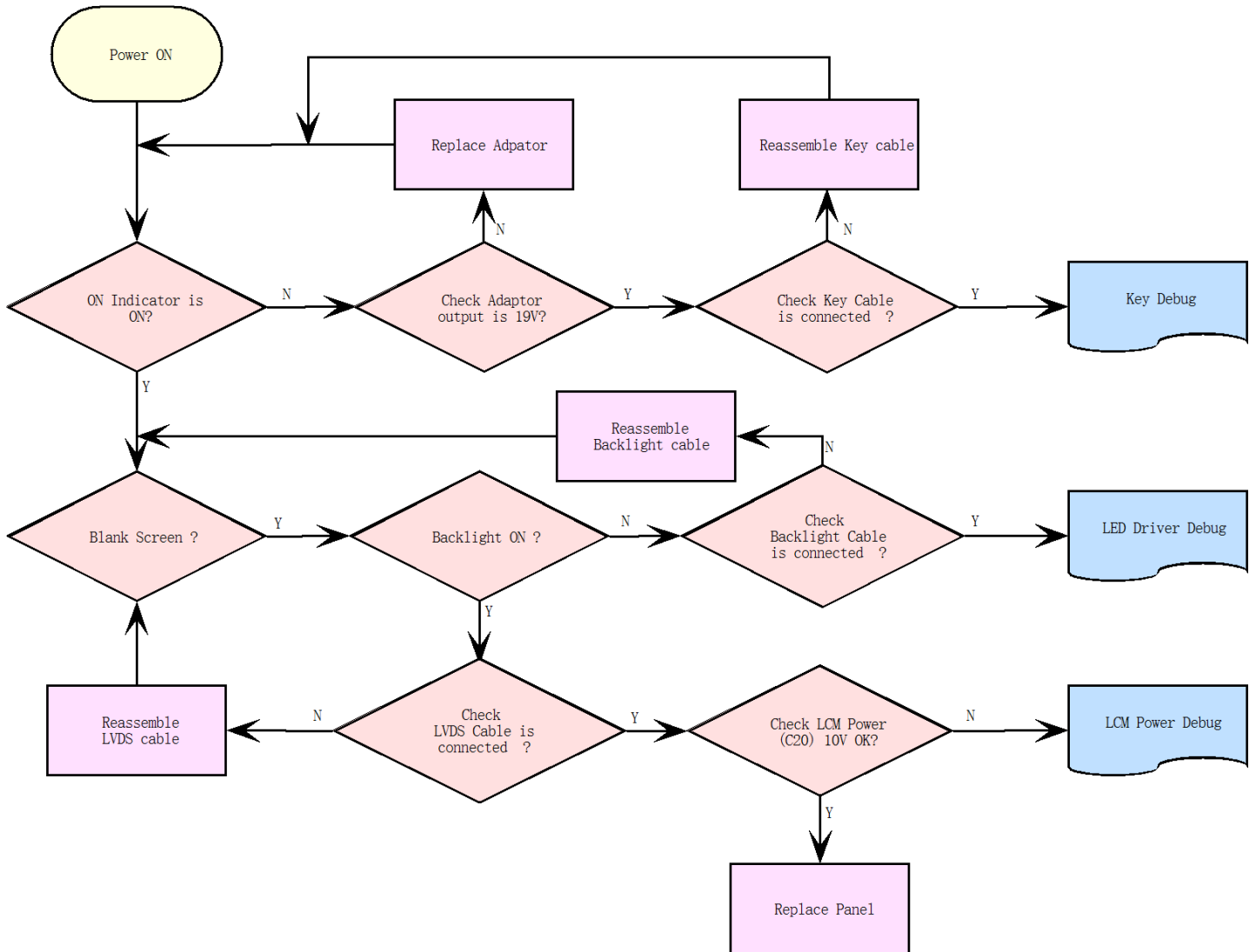

5.2 Key debug flow:

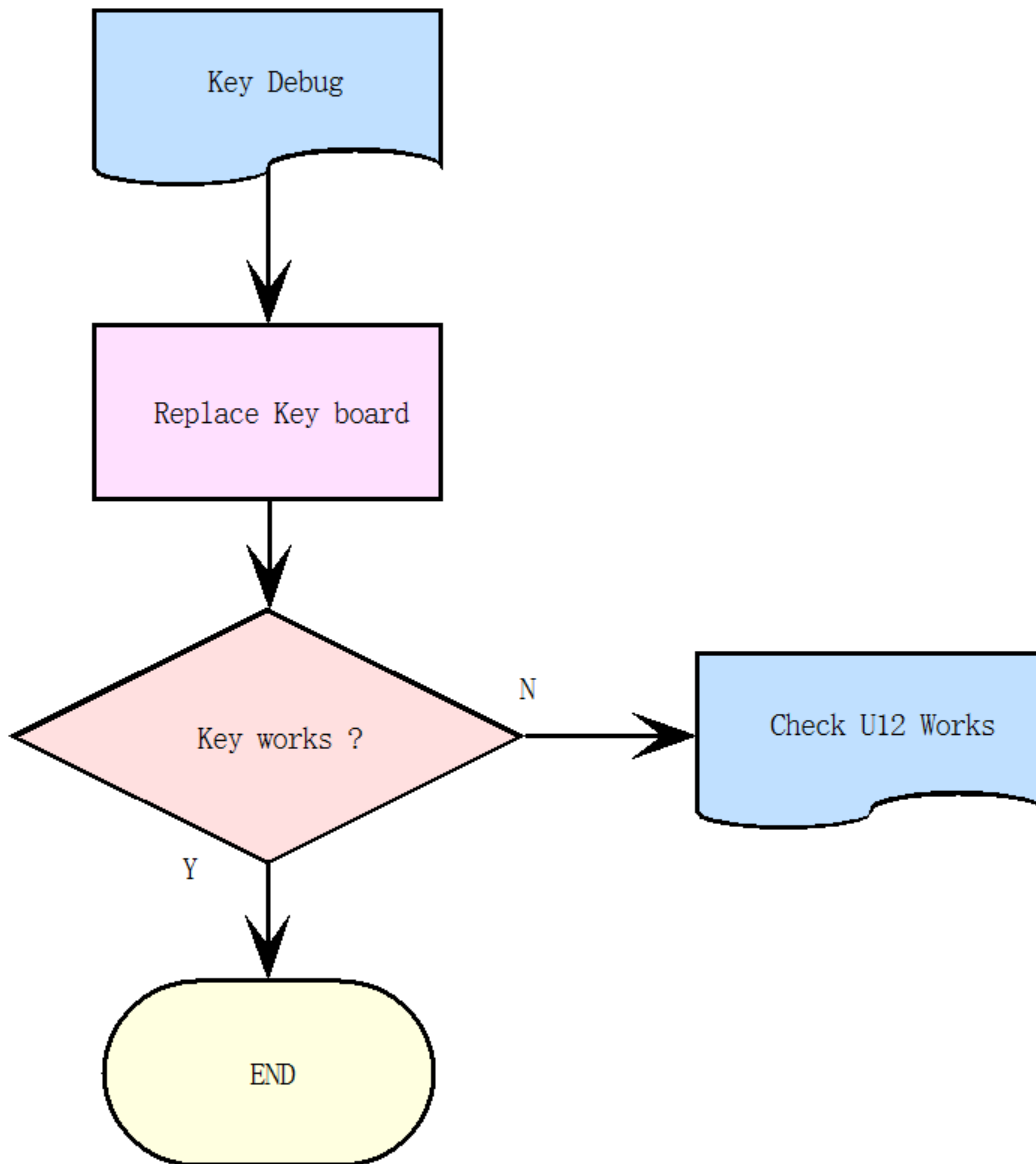



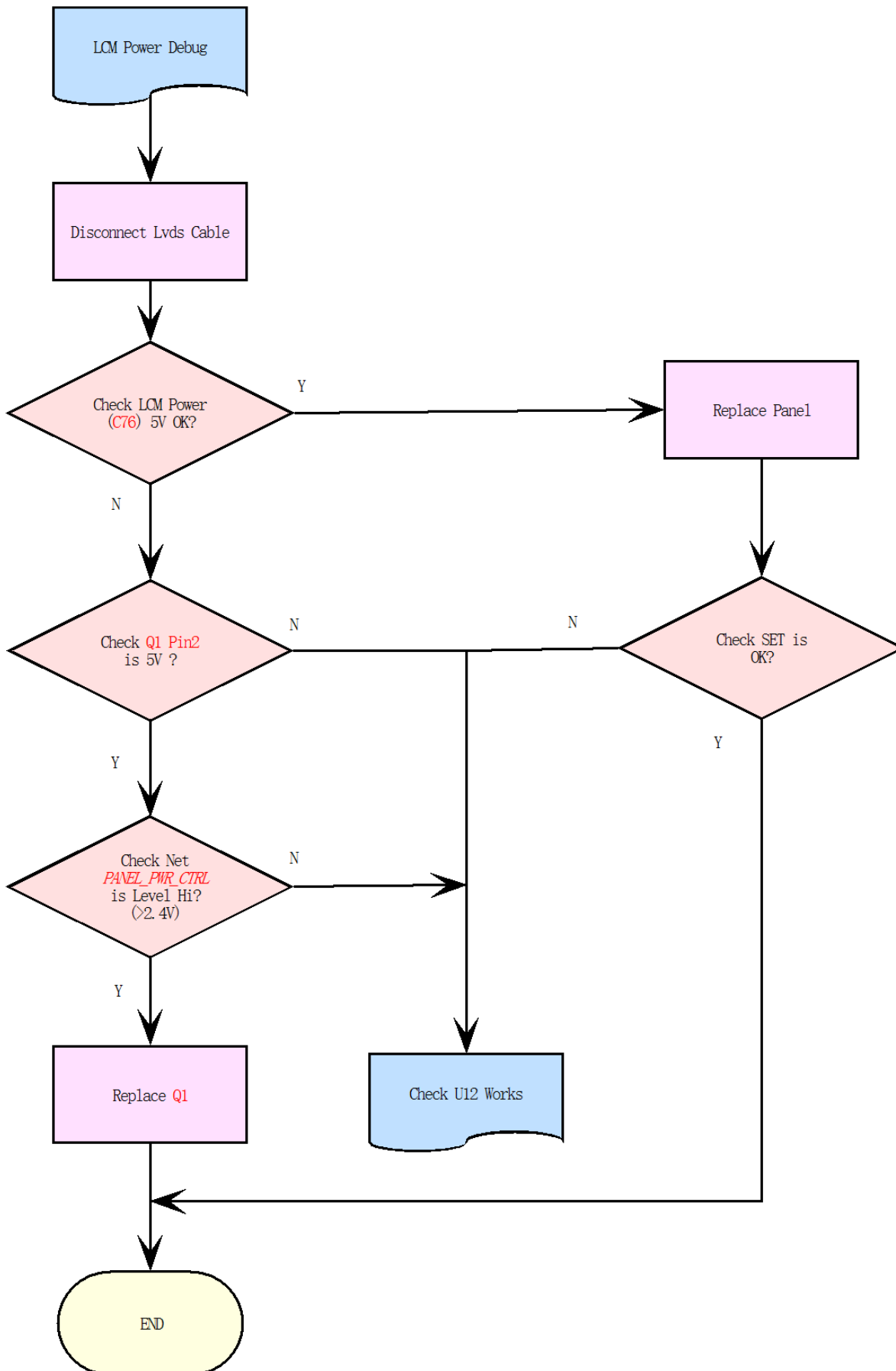

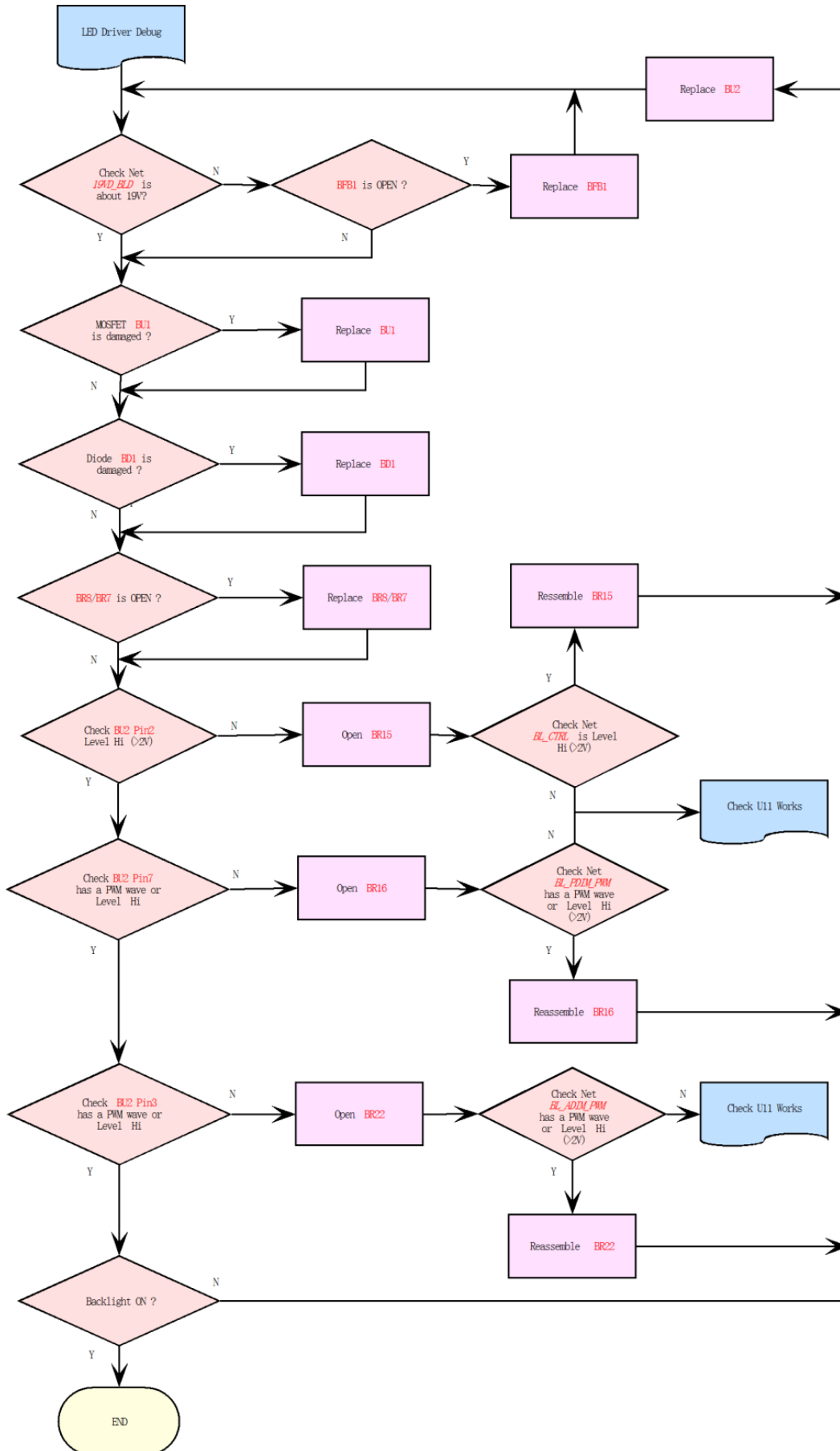

5.3 Power debug flow:



5.4 Panel debug flow:



6. FRU (Field Replaceable Unit) List

Parts Photo	SPL_Category	Acer PN	Raken PN	ODM Description
	ADAPTOR	25.T0LM5.002	R030070131475	A-D adapter 1.58 A 19V ADS-40SI-19-3 19030E(VI) _ ACER G247HYL
	BOARD	55.TDYM5.001	352701420156	DISPLAY BD ASSY ACER RG270 bmiix
	BOARD	55.TDXM5.001	352407420150	MB ASSY ACER RG241Y bmiix_LM238WF2-RSARC_RTD2523T-CG (HDCP)
	CABLE	50.T6KM5.001	R046428080860	WH FFC 8P(0.5mm)235mm(1FOLD)60V G/F (A8+A5)LF
	CABLE	50.TB2M5.001	R046428301780	WH FFC 30P(1.0mm)285mm(2FOLD)60V G/F W/CONN.(A5+BC)+AL(AA) LF ip
	CABLE	50.T6PM5.001	R046610060591	WH A1251Y-06/CH13100V06 #28 320mm W/B LF
	LCD	KL.23802.009	R352400120395	Acer RA241 model LCM Part NO

Free Manuals Download Website

<http://myh66.com>

<http://usermanuals.us>

<http://www.somanuals.com>

<http://www.4manuals.cc>

<http://www.manual-lib.com>

<http://www.404manual.com>

<http://www.luxmanual.com>

<http://aubethermostatmanual.com>

Golf course search by state

<http://golfingnear.com>

Email search by domain

<http://emailbydomain.com>

Auto manuals search

<http://auto.somanuals.com>

TV manuals search

<http://tv.somanuals.com>