



User Manual

IDK-2119 Series

**19" High Brightness SXGA
LED-Backlight Display**

ADVANTECH

Enabling an Intelligent Planet

Copyright

The documentation and software included with this product are copyrighted 2014 by Advantech Co., Ltd. All rights are reserved. Advantech Co., Ltd. reserves the right to improve the products described in this manual at any time without notice. No part of this manual may be reproduced, copied, translated or transmitted in any form or by any means without the prior written permission of Advantech Co., Ltd. Information provided in this manual is intended to be accurate and reliable. However, Advantech Co., Ltd. assumes no responsibility for its use, nor for any infringements of the rights of third parties that may result from its use.

Acknowledgements

AMI is a trademark of American Megatrends Inc.

IBM and PC are trademarks of International Business Machines Corporation.

Intel® Core 2 Quad, Pentium Dual-Core and Celeron are trademarks of Intel Corporation.

WinBond is a trademark of Winbond Corporation.

All other product names or trademarks are properties of their respective owners.

Message to the Customer

Advantech Customer Services

All Advantech products are built to the most precise specifications to ensure reliable performance in the harsh and demanding conditions typical of industrial environments. Regardless of whether your new Advantech equipment is destined for a laboratory or factory floor, you can be assured that your product will provide the reliability and ease of operation for which Advantech is renowned.

Your satisfaction is our primary concern. To ensure you receive the full benefit of our services, please follow the instructions in this guide.

Technical Support

We want you to experience the maximum performance of your products. Should you encounter technical difficulties, we are available to provide assistance. Answers to the most frequently asked questions are provided in the product documentation. Generally, these answers are more detailed than the information we can offer over the telephone. So please consult this manual first. If you still cannot find the answer, gather all the information or questions that apply to your problem, and with the product close at hand, contact your dealer.

Our dealers are well trained and ready to provide the support you need to get the most from your Advantech products. In fact, most of the problems reported are minor and easily resolved over the telephone.

In addition, free technical support from Advantech engineers is available during business hours. We are always ready to offer advice regarding application requirements or to provide specific information related to the installation and operation of any of our products.

Product Warranty (2 years)

Advantech warrants the original purchaser that all products will be free from defects in materials and workmanship for two years from the date of purchase.

This warranty does not apply to products that have been repaired or altered by persons other than repair personnel authorized by Advantech, or products subject to misuse, abuse, accidents or improper installation. Advantech assumes no liability under the terms of this warranty as a consequence of such events.

Because of Advantech's high quality-control standards and rigorous testing, most of our customers never need to use our repair service. If an Advantech product is defective, it will be repaired or replaced at no charge during the warranty period. For out-of-warranty repairs, customers are billed according to the cost of the replacement materials, service time and freight. Please consult your dealer for more details.

If you believe your product to be defective, please follow the steps listed below:

1. Collect all information regarding the problem encountered. (For example, CPU speed, Advantech products involved, other hardware and software used, etc.) Note anything abnormal and list any onscreen messages you encounter when the problem occurs.
2. Call your dealer and describe the problem. Please have your manual, product number, and related information readily available.
3. If your product is diagnosed as defective, obtain an RMA (return merchandise authorization) number from your dealer. This allows us to process your return more quickly.
4. Carefully pack the defective product, a completed Repair and Replacement Order Card and a proof of purchase date (such as a photocopy of your sales receipt) in a shippable container. Products returned without a proof of purchase date will not be eligible for our warranty service.
5. Write the RMA number clearly on the outside of the packaging before shipping the product prepaid to your dealer.

Contents

Chapter 1	Overview.....	1
1.1	General Description	2
1.2	Specifications	2
1.2.1	LCD Panel.....	2
1.2.2	LED Driver Board.....	2
1.2.3	Touchscreen (R series).....	2
1.2.4	Environment.....	2
1.3	Mechanical Characteristics	3
1.3.1	IDK-2119N-K2SXA2E	3
1.3.2	IDK-2119R-K2SXA2E	5
1.4	Functional Block Diagram	7
	Figure 1.1 Functional block diagram.....	7
1.5	Touchscreen Driver.....	7
1.6	Absolute Maximum Ratings	7
1.6.1	Absolute Ratings for TFT LCD Module	7
1.6.2	Absolute Ratings for Backlight Unit.....	7
1.6.3	Absolute Environmental Ratings.....	8
Chapter 2	Electrical Characteristics.....	9
2.1	Power Specifications.....	10
	Table 2.1: Power Specifications	10
2.2	Backlight Driving Conditions	10
	Table 2.2: Backlight Driving Conditions.....	10
Chapter 3	Signal Characteristics.....	13
3.1	Pixel Format Image	14
3.2	Pin Description	14
	Table 3.1: Pin Description	14
3.3	Input Data Format	16
3.4	Interface Timing	16
3.4.1	Timing Characteristics	16
	Table 3.2: Timing Characteristics	16
3.4.2	Input Timing Diagram.....	17
3.5	Power ON/OFF Sequence	17
Chapter 4	Connector and Pin Assignment	19
4.1	TFT LCD Module.....	20
4.1.1	Connectors.....	20
	Table 4.1: Connectors	20
4.1.2	Pin Assignment.....	20
	Table 4.2: Pin Assignment.....	20
4.2	Backlight Unit	20
4.2.1	LED Light Bar Connector Signals	21
4.2.2	LED Driver Board.....	21
	Table 4.3: Specifications	21
	Table 4.4: Input Connector Pin Definition (CN4)	22
	Table 4.5: Output Connector Pin Definition (CN1 and CN2)	22
	Figure 4.1 Dimensions.....	22

Chapter 5	Touchscreen and Controller	23
5.1	Touchscreen (Optional: for IDK-2119R only).....	24
5.1.1	Touch Characteristics	24
5.1.2	Optical Characteristics.....	24
5.1.3	Environmental Characteristics	24
5.1.4	Mechanical Characteristics.....	24
5.1.5	Electronic Characteristics	24
5.1.6	General Specifications.....	25
5.2	Touch Controller (Optional: for IDK-2119R only)	25
5.2.1	Touch Controller Characteristics	25
5.2.2	Pin Assignment and Description.....	26
	Figure 5.1 Board-mounted header	27
5.2.3	Physical Dimensions.....	28
Appendix A	Optical Characteristics.....	29
A.1	Optical Characteristics	30
	Table A.1: Optical Characteristics	30
Appendix B	Handling Precautions	33
B.1	Handling Precautions.....	34

Chapter 1

Overview

1.1 General Description

The Advantech IDK-2119 series is equipped with a 19" 1200 cd/m² industrial-grade LCD display and LED driver board. This series is also available with various touch-screen options and enhancements, such as AR surface treatment and optical bonding solutions. The IDK-2119 series supports a high brightness of 1200 cd/m² at the maximum power consumption of 29.61 W. Featuring a high level of brightness and wide operating temperature range, IDK-2119 provides superior sunlight readability and is ideal for both semi-outdoor and outdoor environments.

1.2 Specifications

1.2.1 LCD Panel

- **Display Size:** 19" LED backlight panel
- **Resolution:** 1280 x 1024
- **Viewing Angle (U / D / L / R):** 80° / 80° / 85° / 85°
- **Brightness:** 1200 cd/m²
- **Contrast Ratio:** 1100:1
- **Response Time (ms):** 5 ms
- **Colors:** 16.7 M
- **Voltage:** 5 V
- **Power Consumption:** 30.19 W
- **Signal Interface:** Two-channel LVDS
- **Weight:** R series: 2800g (typical)
N series: 1700g (typical)
- **Dimensions (W x H x D):** N series: 396 (H) x 324 (V) x 17.8 (D) (typical)
R series: 396 (H) x 324 (V) x 21.7 (D) (typical)

1.2.2 LED Driver Board

- **Efficiency:** 92%
- **Output Current and Voltage:** 1340 mA / 17.5 V (typical)
- **Dimensions (W x H x D):** 80 x 54.2 x 16 mm

1.2.3 Touchscreen (R series)

- **Touchscreen:** 5-wire resistive
- **Light Transmission:** 80 ± 3%
- **Durability:** x10 million

1.2.4 Environment

- **Operating Temperature:** 0 ~ 50 °C
- **Storage Temperature:** -20 ~ 60 °C
- **Humidity:** 5 ~ 95% @ 40 °C, non-condensing

1.3 Mechanical Characteristics

1.3.1 IDK-2119N-K2SXA2E

Front View

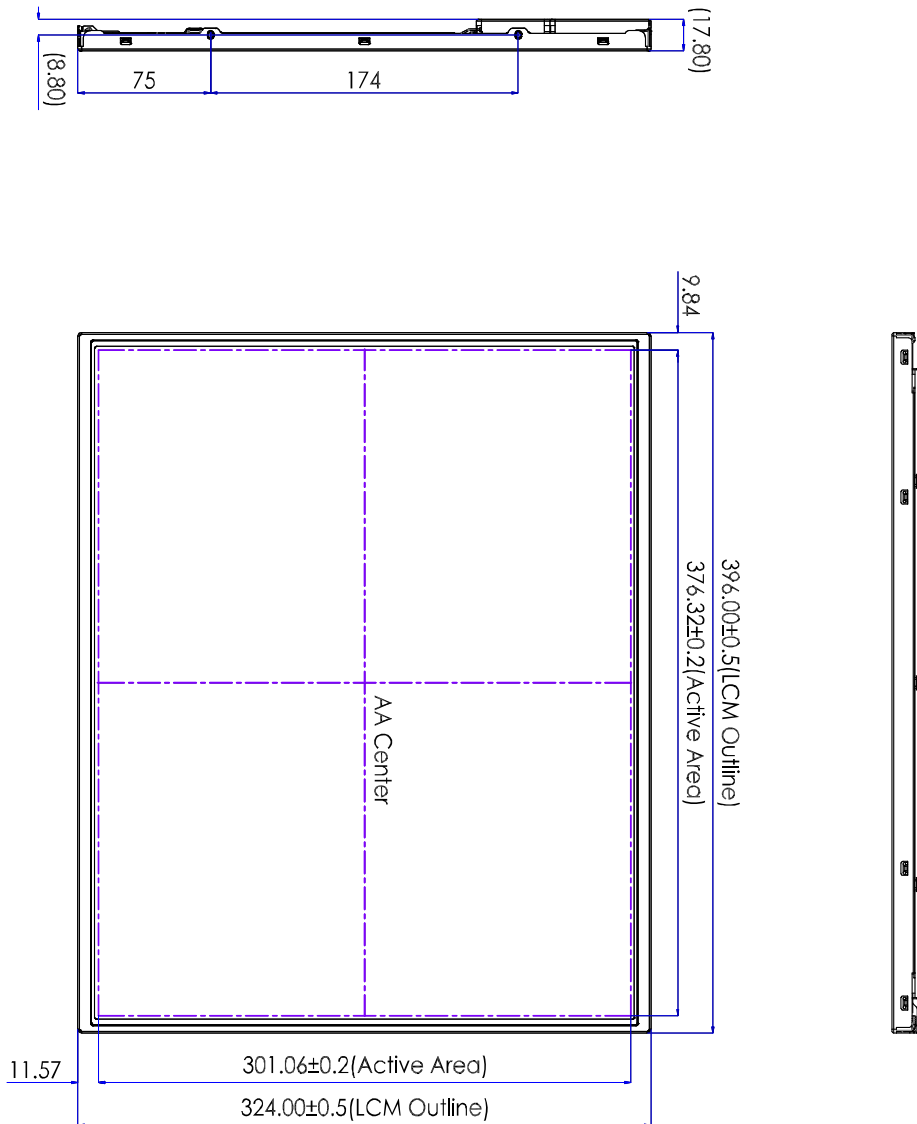

Rear View

M3 User Hole - 4X
Depth=4.0mm
Max

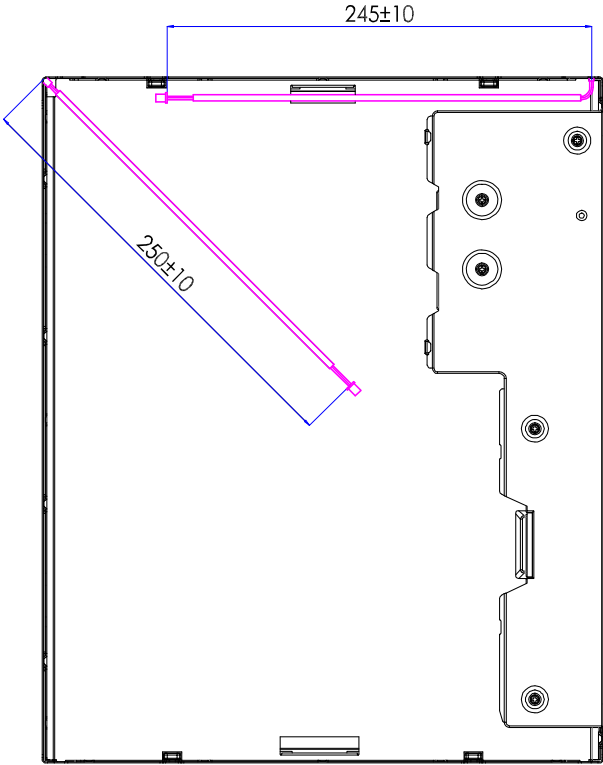
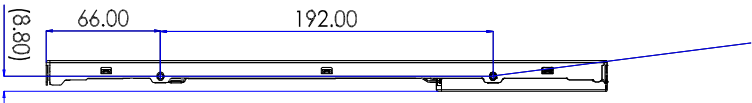

1.3.2 IDK-2119R-K2SXA2E

Front View

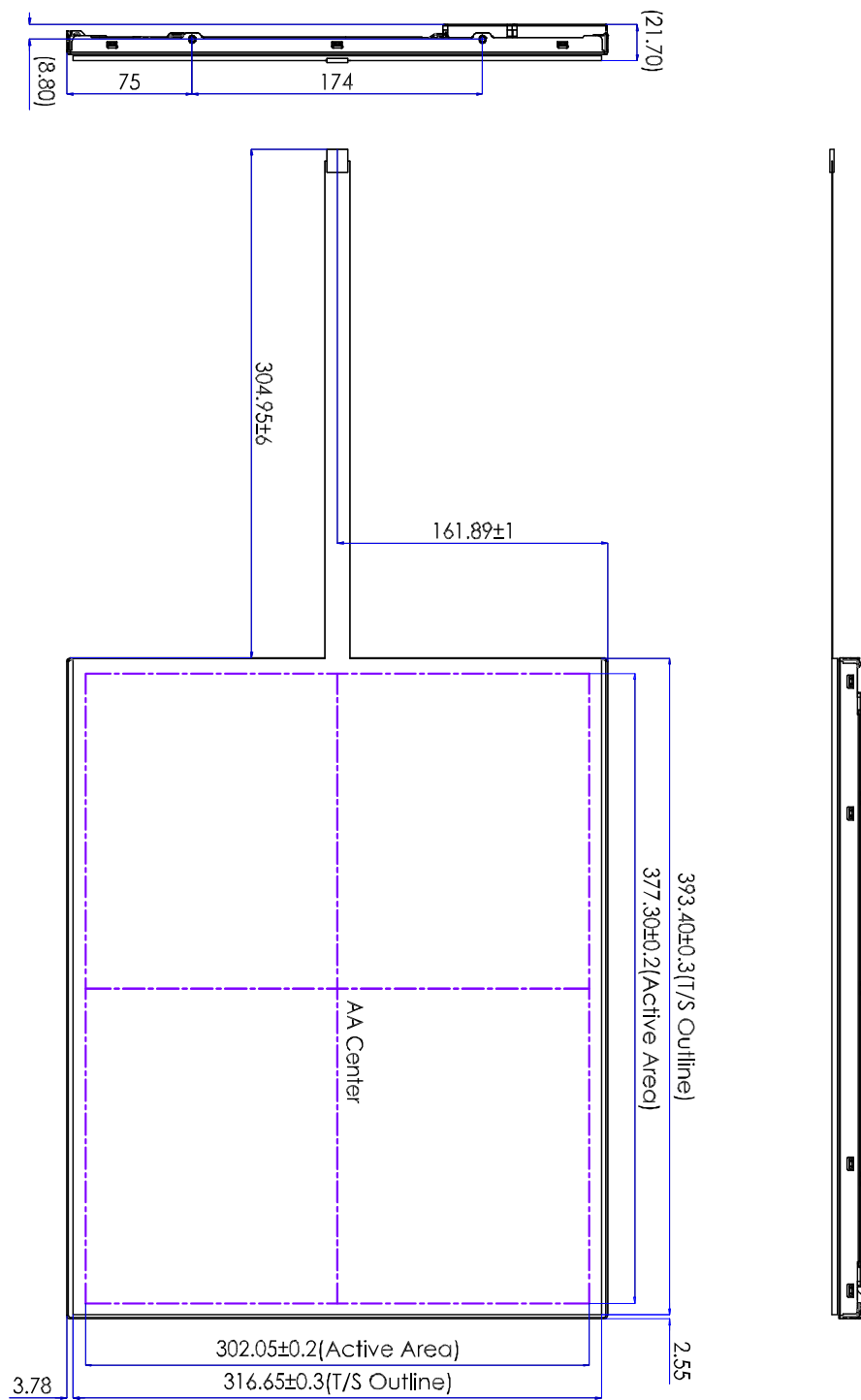

Rear View

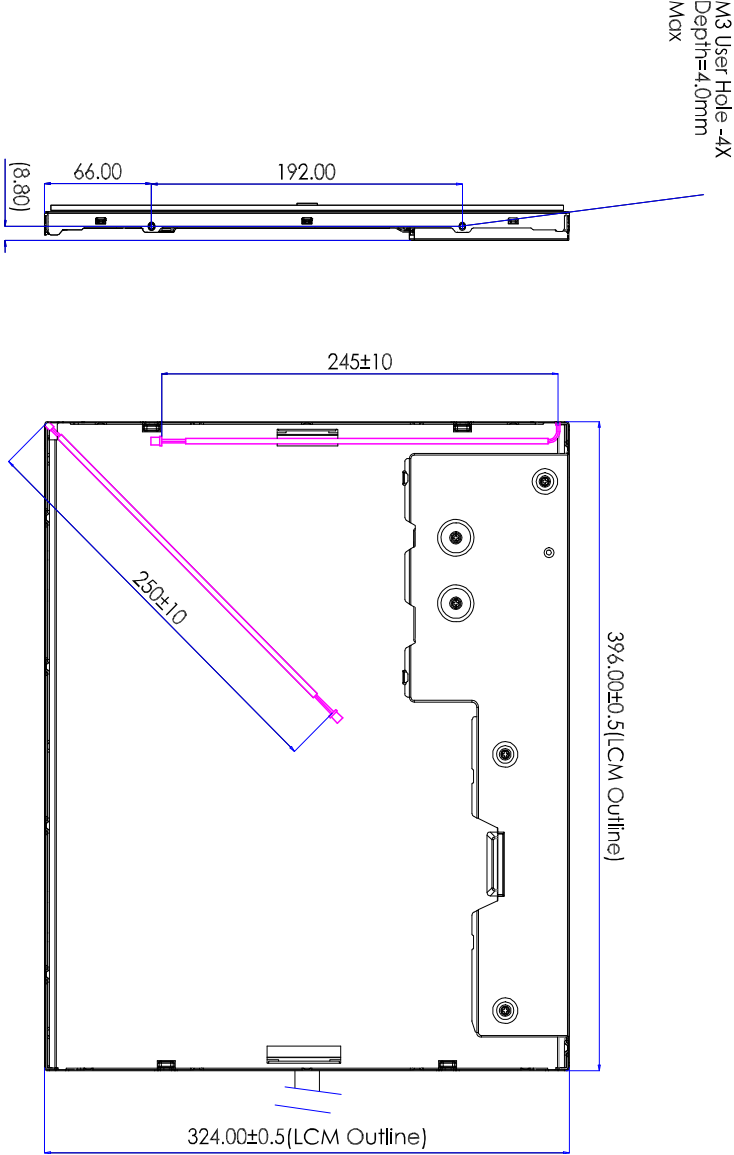

1.4 Functional Block Diagram

Below is a functional block diagram of the 19-inch color TFT-LCD module.

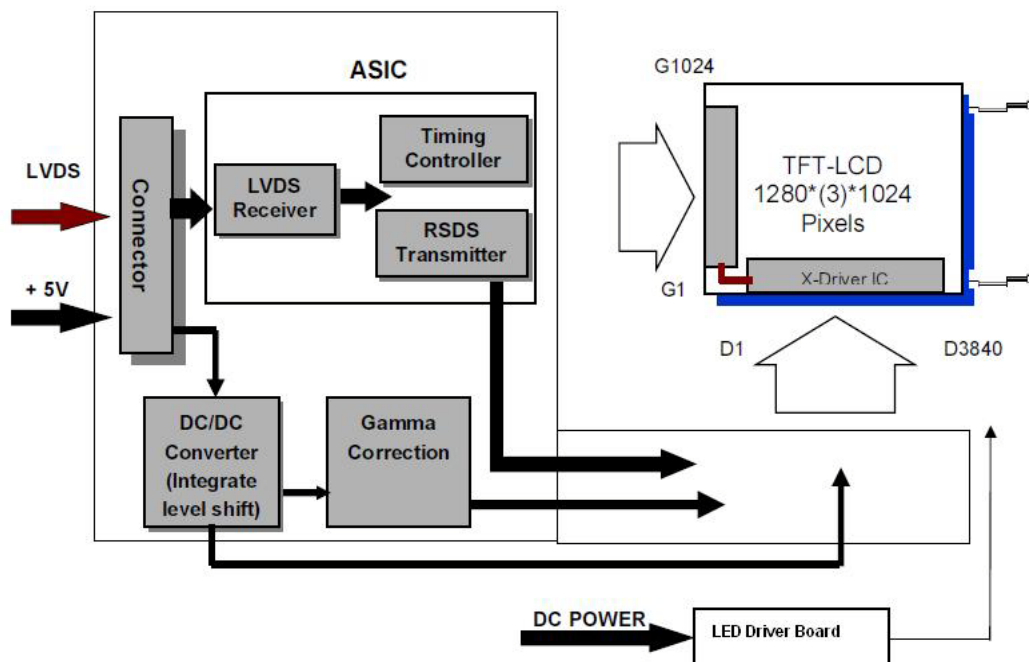

Figure 1.1 Functional block diagram

1.5 Touchscreen Driver

Please download the touchscreen driver from www.advantech.com

1.6 Absolute Maximum Ratings

The absolute maximum allowable ratings for this module are as follows:

1.6.1 Absolute Ratings for TFT LCD Module

Item	Symbol	Min.	Max.	Unit	Conditions
Logic/LCD Drive Voltage	VDD	-0.3	+5.5	[Volt]	Notes 1 and 2

1.6.2 Absolute Ratings for Backlight Unit

Item	Symbol	Min.	Max.	Unit	Conditions
LED Light Bar Current	ILed	670*2		[mA]	Notes 1 and 2

1.6.3 Absolute Environmental Ratings

Item	Symbol	Min.	Max.	Unit	Conditions
Operating Temperature	TOP	0	+50	[°C]	
Operating Humidity	HOP	8	90	[%RH]	
Storage Temperature	TST	-20	+60	[°C]	
Storage Humidity	HST	8	90	[%RH]	

Note 1: Ta must not exceed 25 °C

Note 2: Permanent damage to the device may occur if the maximum values are exceeded.

Chapter 2

Electrical
Characteristics

2.1 Power Specifications

The input power specifications are as follows:

Table 2.1: Power Specifications

Symbol	Parameter	Min.	Typ.	Max.	Unit	Condition
VCC	Logic/LCD Drive Voltage	4.5	5.0	5.5	[Volt]	±10%
ICC	Input Current	-	0.94	1.1	[A]	V _{in} = 5.0 V; all white pattern; at 60 Hz
PCC	VCC Power	-	4.7	5.5	[Watt]	V _{in} = 5.0 V; all white pattern; at 60 Hz
IRush	Inrush Current	-	2.1	2.5	[A]	Note 1

Note 1: Measurement condition

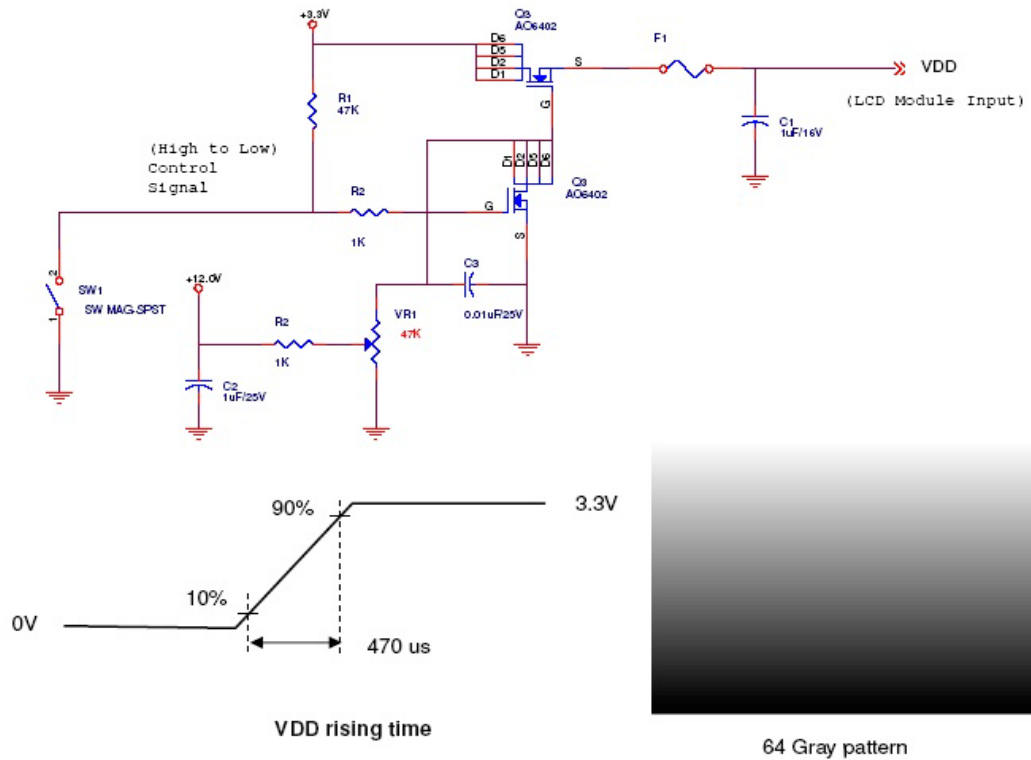

2.2 Backlight Driving Conditions

The parameter guideline of the LED light bar driver is 25 °C (room temperature) at stable condition.

Table 2.2: Backlight Driving Conditions

Item	Symbol	Values			Unit	Condition
		Min.	Typ.	Max.		
LED Voltage	V _L	-		17.5	V	Notes 2 and 3
LED Current	I _L	-		670*2	mA	Note 2
LED Lifetime	-	50,000	-	-	Hr	Note 1

Note 1: The LED lifetime is defined as the time before the module brightness decreases to 50% of the original brightness when at an ambient temperature of 25 °C, with a typical LED current of 800 mA.

Note 2: The LED driving condition is defined for each LED module (6 LED serial).

Note 3: The variance in power consumed by the LED light bar is 10%. PLED is the calculated reference value ($P_{LED} = I_L \times V_L \times 2$)

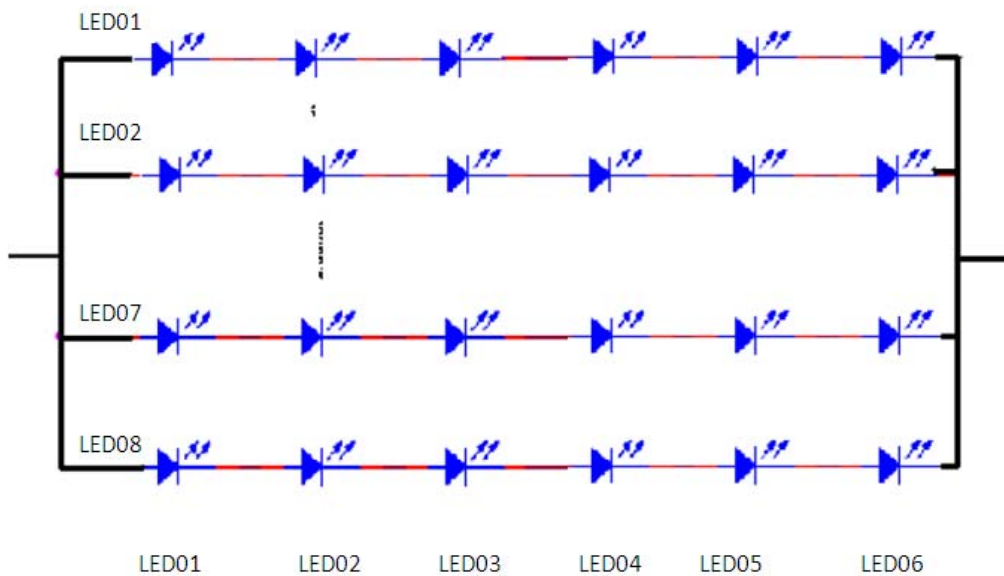

Chapter 3

Signal Characteristics

3.1 Pixel Format Image

The following figure shows the relationship between input signals and the LCD pixel format.

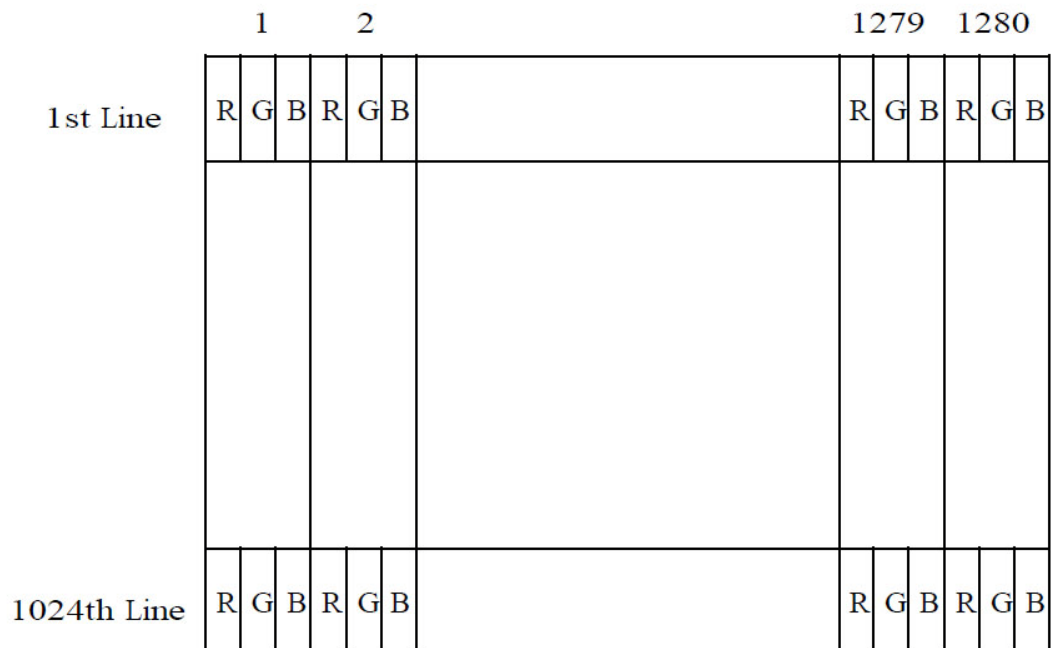

3.2 Pin Description

The module uses a pair of LVDS-compatible SN75LVDS82 receivers (Texas Instruments). LVDS is a differential signaling technology developed for LCD interfaces and high-speed data transfer devices. Additionally, the device transmitters are SN75LVDS83 compatible (negative edge sampling). The first LVDS port (RxOxxx) transmits odd pixels and the second LVDS port (RxExxx) transmits even pixels.

Table 3.1: Pin Description

Pin No.	Symbol	Description
1	RxOIN0-	Negative LVDS differential data input (odd data)
2	RxOIN0+	Positive LVDS differential data input (odd data)
3	RxOIN1-	Negative LVDS differential data input (odd data)
4	RxOIN1+	Positive LVDS differential data input (odd data)
5	RxOIN2-	Negative LVDS differential data input (odd data, H-Sync, V-Sync, DSPTMG)
6	RxOIN2+	Positive LVDS differential data input (odd data, H-Sync, V-Sync, DSPTMG)
7	VSS	Power ground
8	RxOCLKIN-	Negative LVDS differential clock input (odd clock)
9	RxOCLKIN+	Positive LVDS differential clock input (odd clock)
10	RxOIN3-	Negative LVDS differential data input (odd data)
11	RxOIN3+	Positive LVDS differential data input (odd data)
12	RxEIN0-	Negative LVDS differential data input (even data)
13	RxEIN0+	Positive LVDS differential data input (even data)
14	VSS	Power ground

Table 3.1: Pin Description		
15	RxEIN1-	Negative LVDS differential data input (even data)
16	RxEIN1+	Positive LVDS differential data input (even data)
17	VSS	Power ground
18	RxEIN2-	Negative LVDS differential data input (even data)
19	RxEIN2+	Positive LVDS differential data input (even data)
20	RxECLKIN-	Negative LVDS differential clock input (even clock)
21	RxECLKIN+	Positive LVDS differential clock input (even clock)
22	RxEIN3-	Negative LVDS differential data input (even data)
23	RxEIN3+	Positive LVDS differential data input (even data)
24	VSS	Power ground
25	VSS	Power ground
26	NC	No contact
27	VSS	Power ground
28	VCC	+5.0 V power supply
29	VCC	+5.0 V power supply
30	VCC	+5.0 V power supply

3.3 Input Data Format

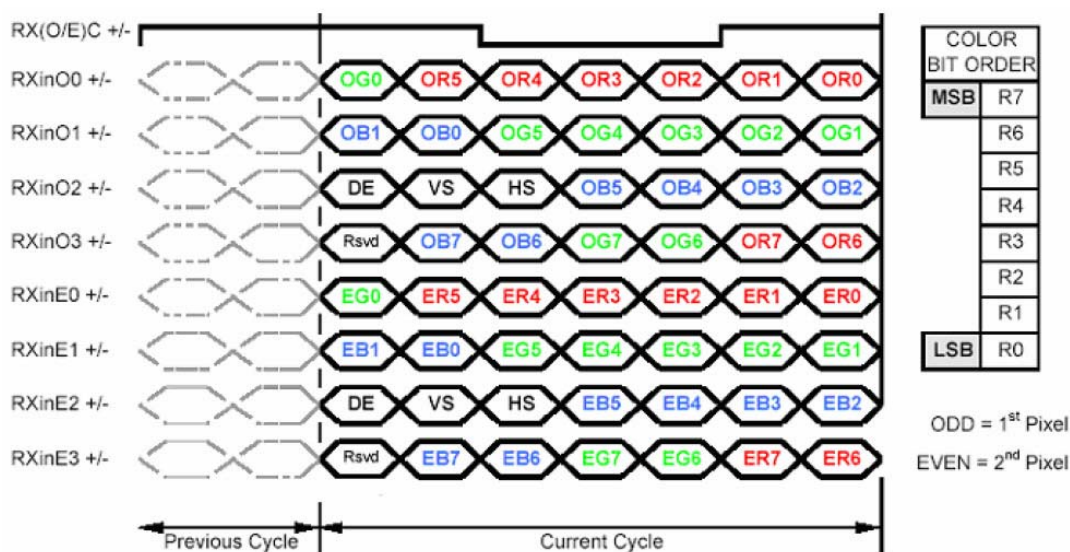

Note 1: Typically, DE mode only. VS and HS on the EVEN channel are not used.

Note 2: Please follow VESA.

Note 3: 8-bit input

3.4 Interface Timing

3.4.1 Timing Characteristics

Table 3.2: Timing Characteristics

Signal	Item	Symbol	Min.	Typ.	Max.	Unit
Vertical Section	Period	T_V	1032	1066	1150	T_H
	Active	$T_{disp(V)}$	1024	1024	1024	T_H
	Blanking	$T_{bp(V)}+T_{fp(V)}+PW_{VS}$	8	42	126	T_H
Horizontal Section	Period	T_H	780	844	2047	T_{Clock}
	Active	$T_{disp(H)}$	640	640	640	T_{Clock}
	Blanking	$T_{bp(H)}+T_{fp(H)}+PW_{HS}$	140	204	-	T_{Clock}
Clock	Period	T_{Clock}	22.2	18.52	14.81	ns
	Frequency	Freq	45	54	67.5	MHz
Frame Rate	Frequency	$1/T_V$	50	60	75	Hz

Note 1: DE mode

3.4.2 Input Timing Diagram

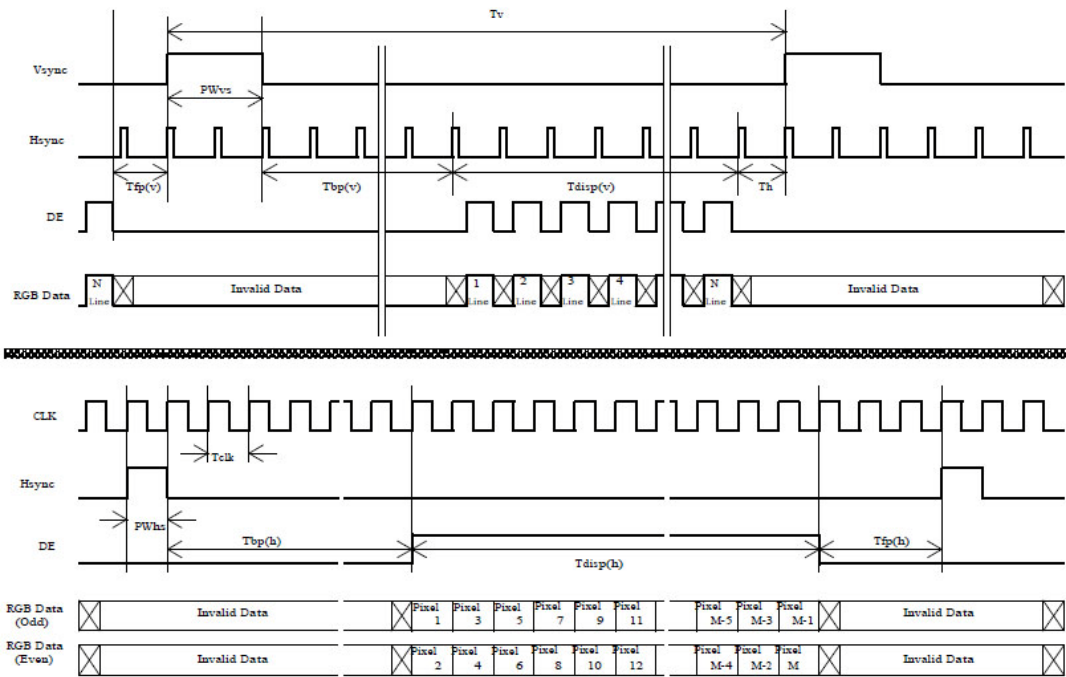

3.5 Power ON/OFF Sequence

The VDD power and lamp ON/OFF sequence, in addition to the interface signals, are shown below. Signals from any system should be in Hi-Z state or at a low level when the VDD is off.

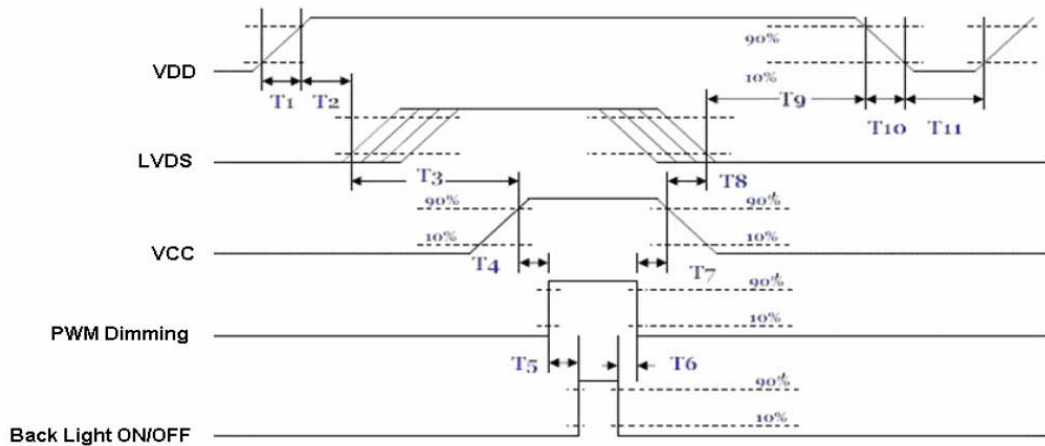

Power Sequence Timing

Parameter	Value			Unit
	Min.	Typ.	Max.	
T1	0.5	-	10	[ms]
T2	30	40	50	[ms]
T3	175	-	-	[ms]
T4	10	-	-	[ms]
T5	10	-	-	[ms]
T6	0	-	-	[ms]
T7	10	-	-	[ms]
T8	100	-	-	[ms]
T9	0	16	50	[ms]
T10				[ms]
T11	1000			[ms]

Chapter 4

Connector and Pin Assignment

4.1 TFT LCD Module

The physical interface of the connectors on the TFT LCD module are described in this section. The components and signals accommodated by these connectors are as follows:

4.1.1 Connectors

Table 4.1: Connectors

Connector Name / Description	Interface Connector / Interface Card
Manufacturer	JAE / P-TWO
Type / Part Number	FI-XB30SSLA-HF15 / 187034-30091
Mating Housing Part Number	FI-X30HL FI-X30H (unlocked type)

4.1.2 Pin Assignment

Table 4.2: Pin Assignment

Pin No.	Signal Name	Pin No.	Signal Name
1	RxOIN0-	2	RxOIN0+
3	RxOIN1-	4	RxOIN1+
5	RxOIN2-	6	RxOIN2+
7	VSS	8	RxOCLKIN-
9	RxOCLKIN+	10	RxOIN3-
11	RxOIN3+	12	RxEIN0-
13	RxEIN0+	14	VSS
15	RxEIN1-	16	RxEIN1+
17	VSS	18	RxEIN2-
19	RxEIN2+	20	RxECLKIN-
21	RxECLKIN+	22	RxEIN3-
23	RxEIN3+	24	VSS
25	VSS	26	NC
27	VSS	28	VCC
29	VCC	30	VCC

4.2 Backlight Unit

The physical interface of the backlight unit is as described for the connectors on the module. The components and signals accommodated are explained in the following section.

4.2.1 LED Light Bar Connector Signals

	Connector No.	Pin No.	Input	Color	Function
Upper	CN1	1	HI 1	Red	Power supply for backlight unit
		2	GND 1	Black	Ground for backlight unit
Lower	CN2	1	HI 2	Red	Power supply for backlight unit
		2	GND 2	Black	Ground for backlight unit

Cable Length: 250 mm+ / -10 mm

4.2.2 LED Driver Board

Connector Name / Description	LED driver board input connector
Manufacturer	JST
Connector Model Number	BH6B-PH or equivalent
Adaptable Plug	PHR-6 or equivalent

4.2.2.1 Specifications

Table 4.3: Specifications						
Symbol	Characteristics	Condition	Min.	Typ.	Max.	Unit
Input	Voltage		10.8	12	13.2	V
	Efficiency	$V_{in} = 12\text{ V}$ $I_{out} = 670\text{ mA}$ $V_{out} = 17.5\text{ V}$		92		%
	Power		3		30	W
Output	Voltage		18		24	V
	Current		150		1500	mA
	Current Accuracy	$150\text{ mA} \leq I_{out} \leq$ 1000 mA		± 5	± 10	%
	Protection		Thermal / OVP			
Environment	Thermal Shutdown			165		$^{\circ}\text{C}$
	Operating Junction Temperature				125	$^{\circ}\text{C}$
	Operating Temperature		-30		+85	$^{\circ}\text{C}$
	Storage Temperature		-40		+105	$^{\circ}\text{C}$
PWM Dimmer	Dimmer Range (Note 1)		5		100	V
	Dimmer VH		2		5	V
	Dimmer VL		0		1.5	V
	Dimmer Frequency		0.25	0.5	1	KHz
ON/OFF	On		3.5		5.5	V
	Off		0		2	V

4.2.2.2 Input Connector Pin Definition

Table 4.4: Input Connector Pin Definition (CN4)

Pin No.	Pin Definition
1	Vin (+12 V)
2	Vin (+12 V)
3	GND
4	GND
5	ON/OFF (0V: Off; +5 V: On)
6	Dimming (PWM)

4.2.2.3 Output Connector Pin Definition

Table 4.5: Output Connector Pin Definition (CN1 and CN2)

Pin No.	Pin Definition
1	VLED-
2	VLED+

4.2.2.4 Dimensions

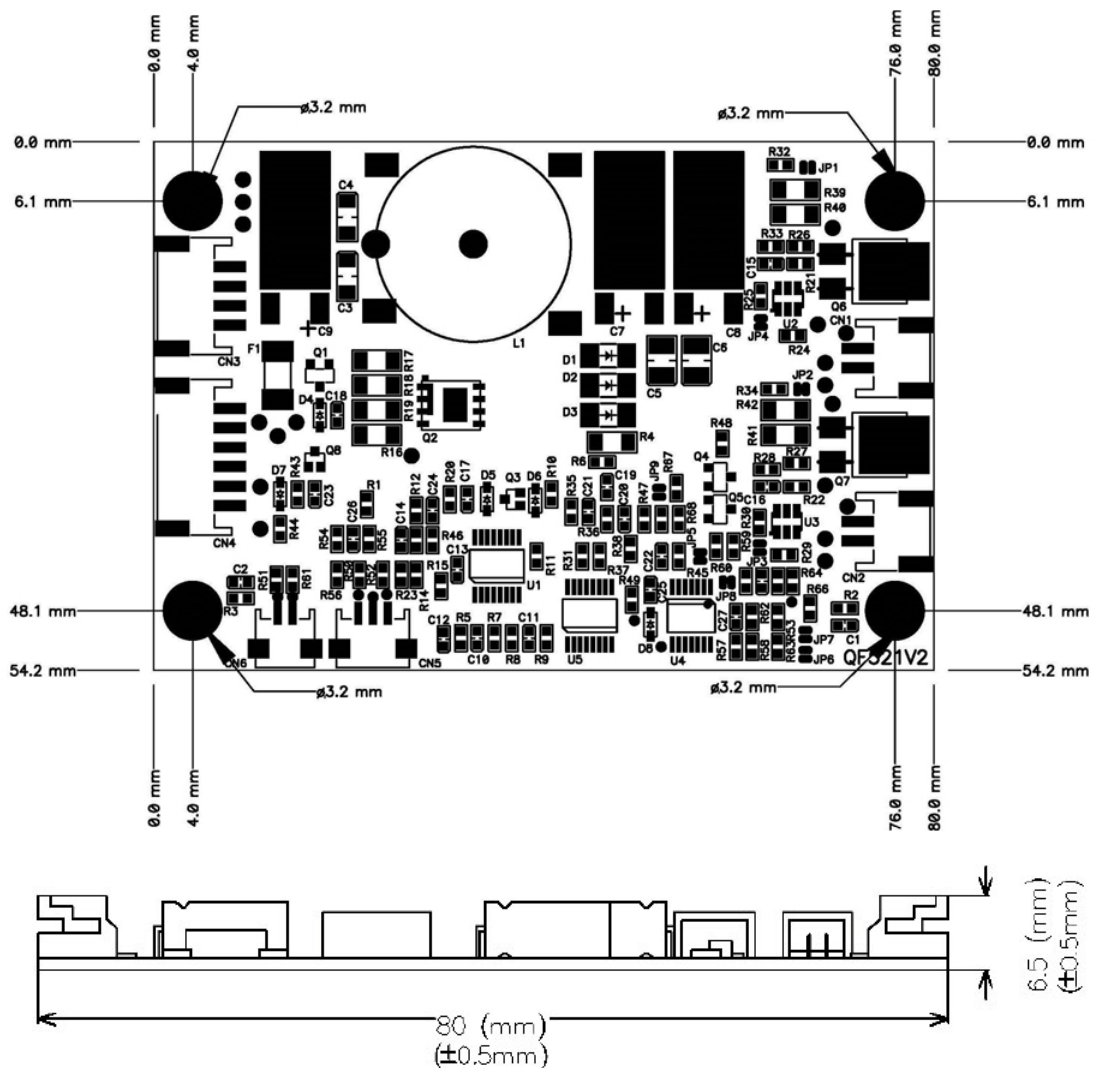

Figure 4.1 Dimensions

Chapter 5

Touchscreen and
Controller

5.1 Touchscreen (Optional: for IDK-2119R only)

5.1.1 Touch Characteristics

The touch panel features a resistive-type touchscreen for use with flat LCD displays. When touched, using either a round-ended resin pen or finger, the touch panel circuit identifies the touch coordinates based on the voltage at the point of contact on the screen.

5.1.2 Optical Characteristics

	Item	Specifications	Remarks
1	Transparency	80% ± 3%	BYK-Gardner
2	Haze	8.0% ± 3%	BYK-Gardner

5.1.3 Environmental Characteristics

	Item	Specifications	Remarks
1	Operating Temperature	-20 ~ 70 °C	Note: All terms under an atmosphere of 1
2	Storage Temperature	-40 ~ 80 °C	
3	Operating Humidity	20 ~ 80%RH	
4	Storage Humidity	20 ~ 90%RH	

5.1.4 Mechanical Characteristics

	Item	Specifications	Remarks
1	Surface Hardness	Pencil hardness 3H.	JIS K-5600-5-4 150gf, 45°
2	FPC Peeling Strength	1) 5N (5N min.) 2) 19.6N (19.6N min.)	1) Peeling upward by 90° 2) Peeling downward by 90°
3	Operating Force	Pen 0.05N ~ 1.96N Finger (5 ~ 200gf)	Dot spacer Within the guaranteed active area, but not on the age resistor or dot spacer.

5.1.5 Electronic Characteristics

	Item	Specifications	Remarks
1	Rated Voltage	DC 7 V max.	
2	Resistance	X axis: 200Ω ~ 500Ω (see figure below) Y axis: 200Ω ~ 800Ω (see figure below)	FPC connector
3	Linearity	X ≤1.5% (see figure below) Y ≤1.5% (see figure below)	Reference: 250 gf
4	Chattering	≤ 15ms max.	
5	Insulation Resistance	≥ 20MΩ min. (DC 25 V)	

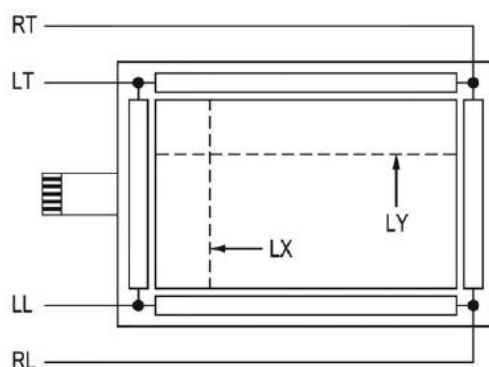

5.1.6 General Specifications

Item	Specifications
1	Frame Size 393.40 ± 0.50 x 316.65 ± 0.50 mm
2	Viewing Area 380.90 ± 0.20 x 305.65 ± 0.20 mm
3	Active Area 377.30±0.20 x 302.05 ± 0.20 mm
4	Total Thickness 3.20 ± 0.20 mm
5	Tail Length 305.0 ± 6.0 mm

5.2 Touch Controller (Optional: for IDK-2119R only)

The Advantech ETM-RES04C Touch Control Board is the ultimate combo board. This touch panel controller enables the optimum performance of analog-resistive touch panels for 5-wire models. The controller communicates with the PC system directly through USB and RS-232 connector. This design delivers superior sensitivity, accuracy and ease of operation. The touch panel driver emulates the left and right button functions of a mouse and has the following features:

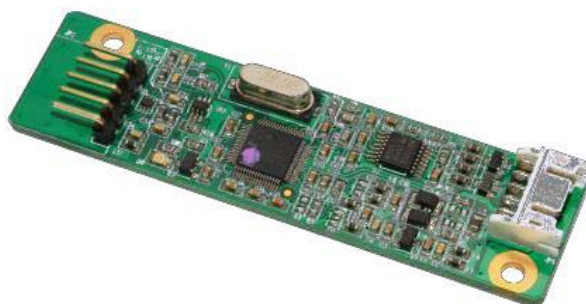

5.2.1 Touch Controller Characteristics

5.2.1.1 Specifications

Electrical Features

- +5 Vdc/ 100 mA typical, 50 mV peak-to-peak maximum ripple and noise
- Bi-directional RS-232 serial communication and full speed USB 1.1
- Maximum report rate is 180 points/sec for RS-232, and 200 points/sec for USB
- Unaffected by environmental EMI.
- The 5-wire model panel resistance is 50 ~ 200 ohm (pin to pin on same layer)
- Touch resistance under 3K ohm

Serial Interface

- EIA 232E (Serial RS-232)
- No parity, 8 data bits, 1 stop bit, 9600 baud (N, 8, 1, 9600)
- Supports Windows 2000 / Vista / XP/ 7, Windows CE 5.0 / 6.0 / 7.0, Windows NT4, Linux, DOS and QNX

USB Interface

- Conforms to full-speed USB, Revision 1.1.
- If the USB is connected to the controller, the controller will communicate via the USB not the serial port.
- Supports Windows 2000/ Vista / XP / 7, Windows CE 5.0 / 6.0 / 7.0, Linux and QNX

Touchscreen Resolution

- Resolution is 2,048 x 2,048

Response Time

- Max. 20 ms

5.2.1.2 Environmental Features

Reliability

- MTBF is 200,000 hours

Temperature Ranges

- Operating temperature = -25 ~ 85 °C
- Storage temperature = -25 ~ 85 °C

Relative Humidity

- Relative humidity is 95% at 60 °C, non-condensing

RoHS certificate complete

Regulatory FCC-B and CE approvals complete

Dimensions: 75 mm x 20 mm x 10 mm

5.2.2 Pin Assignment and Description

5.2.2.1 Connector and LED Locations

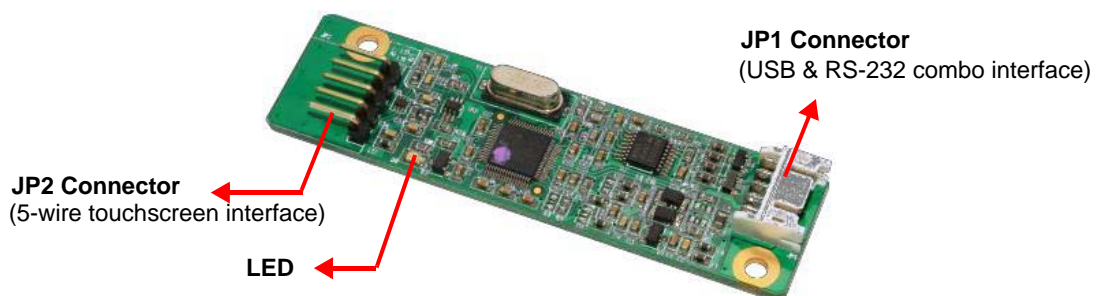

5.2.2.2 JP1 Combo Interface Connector Pins and Signal Descriptions

The combo interface connector, USB and RS-232, is a box, 2.0 mm, 10-pin, 90°, male-type lock connector developed for use with single-wire pins in a 5+5 pin header. The pins are numbered as shown in the following table.

USB Pin #	Signal Name	Signal Function	RS-232 Pin #	Signal Name	Signal Function
1	G	Ground	1	G	Ground
2	V	USB Power	2	V	Power
3	G	Ground	3	G	Ground
4	D+	USB D+	4	TxD	Serial port
5	D-	USB D-	5	RxD	Serial port

Signal Name	DB-9 pin #	RS-232 pin #	Sourced By	Signal Description
RxD	2	5	Ctrl	Serial data from controller to host
TxD	3	4	Host	Serial data from host to controller

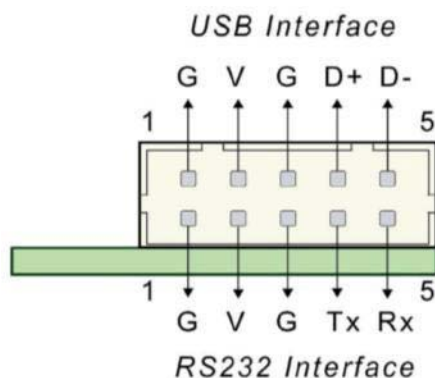
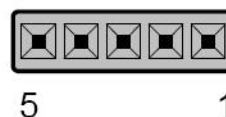
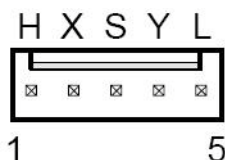
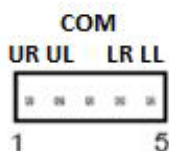

Figure 5.1 Board-mounted header

5.2.2.3 JP2 Touchscreen Connector Pins and Signal Descriptions

The JP2 touchscreen connector is a single row, 2.54 mm, 5-pin, 90°, male-type connector. The pins are numbered as shown in the following table.

JP2 Pin #	Signal Name	Signal Description
1	H / UR	Drive signal attached to the upper right corner of the touchscreen substrate (from the user's perspective).
2	Y / UL	Drive signal attached to the upper left corner of the substrate.
3	COM	-
4	X / LR	Drive signal attached to the lower right corner of the substrate.
5	L / LL	Drive signal attached to the lower left corner of the substrate.



5.2.3 Physical Dimensions

ETM-RES04C-EEH4EE Touch Control Board (unit: mm)

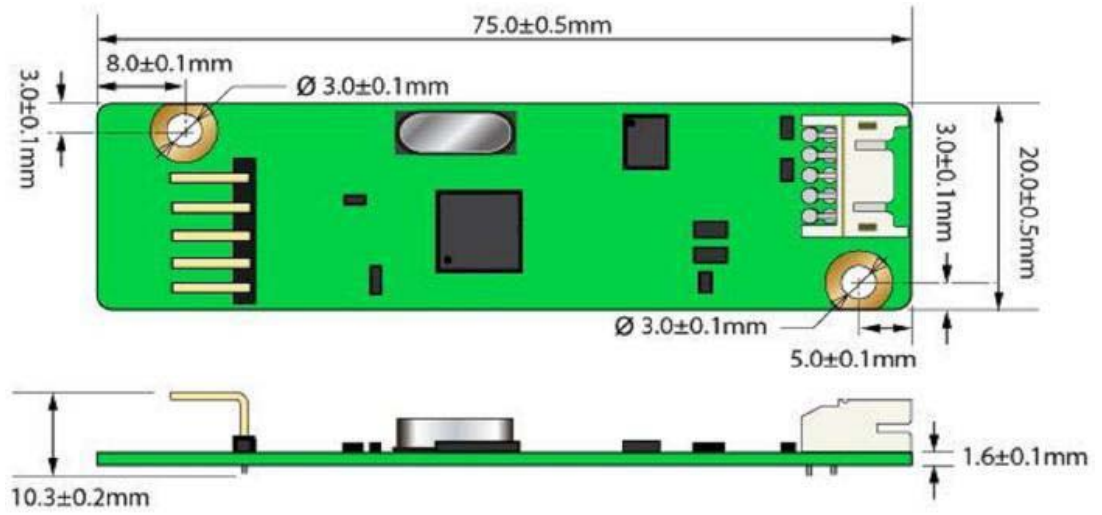

Appendix **A**

Optical Characteristics

A.1 Optical Characteristics

The following optical characteristics are as measured when in stable condition at a room temperature of 25 °C.

Table A.1: Optical Characteristics

Item	Unit	Conditions	Min.	Typ.	Max.	Note
Viewing Angle	[degree]	Horizontal (right)		85	-	1
		CR = 10 (left)		85	-	
		Vertical (up)		80	-	
		CR = 10 (down)		80	-	
Luminance Uniformity	[%]	9 points	75	85	-	2, 3
Optical Response Time	[msec]	Rising	-	3.6	5.7	
		Falling	-	1.4	2.3	5
		Rising and falling	-	5	8	
Color / Chromaticity Coordinates (CIE 1931)		White x	-	0.2582	-	4
		White y	-	0.2614	-	
Color Temp.	K		-	6500	-	
White Luminance	[cd/m ²]		1100	1200	-	4
Contrast Ratio			-	1100	-	

Optical equipment: BM-7, DT-101, or equivalent

Note 1: The viewing angle is defined as the contrast ratio @R10 at the screen center over a 180° horizontal and 180° vertical range (off-normal viewing angles). The 180° viewing angle range is 90° (θ) horizontally left and right, and 90° (Φ) vertically high (up) and low (down). The angle is typically measured from the center of the screen and perpendicular to the display surface when rotating the screen to develop the desired viewing angle.

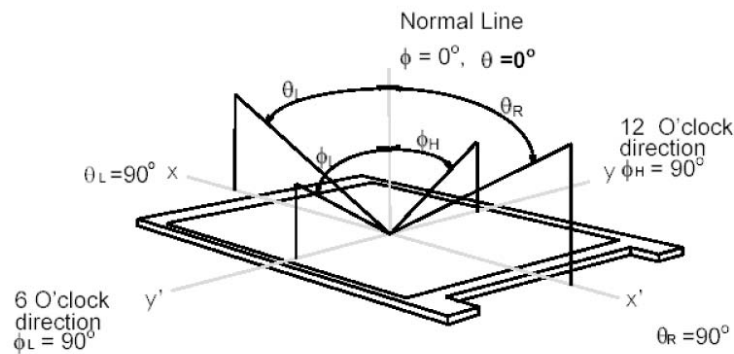

Note 2: The nine-point position

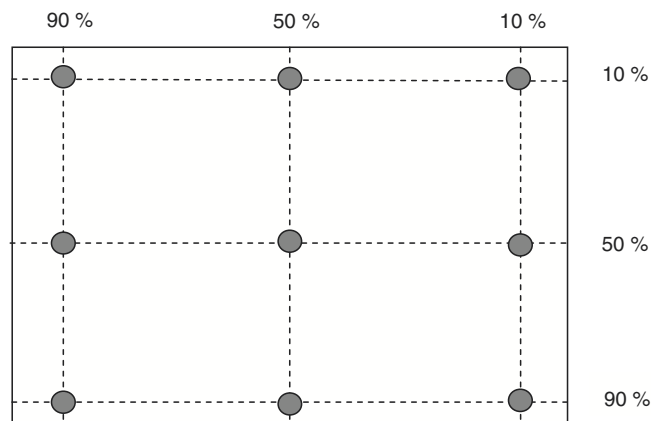

Note 3: The luminance uniformity of the nine points can be determined by dividing the maximum luminance values by the minimum test point luminance

$$\delta_{w9} = \frac{\text{Minimum Brightness of nine points}}{\text{Maximum Brightness of nine points}}$$

Note 4: Regarding the measurement method, the LCD module should be stabilized at a set temperature for 30 minutes to avoid abrupt changes in temperature when measuring. To stabilize the luminance, measurement should be conducted in a dark windowless room after the backlight has been activated for 30 minutes and using DT-100, or an equivalent, as the optical equipment.

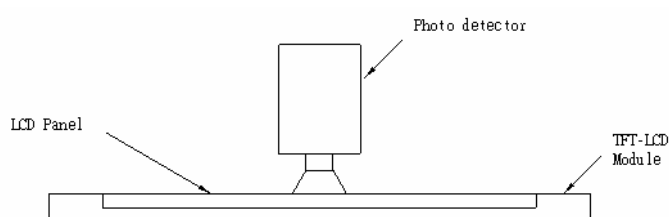

Note 5: Regarding the response time, the photo detector output signals are measured when the input signals are changed from “Full Black” to “Full White” (rising time), and from “Full White” to “Full Black” (falling time). The response time is defined as the interval between the 10% and 90% amplitude points. Please refer to the figure below.

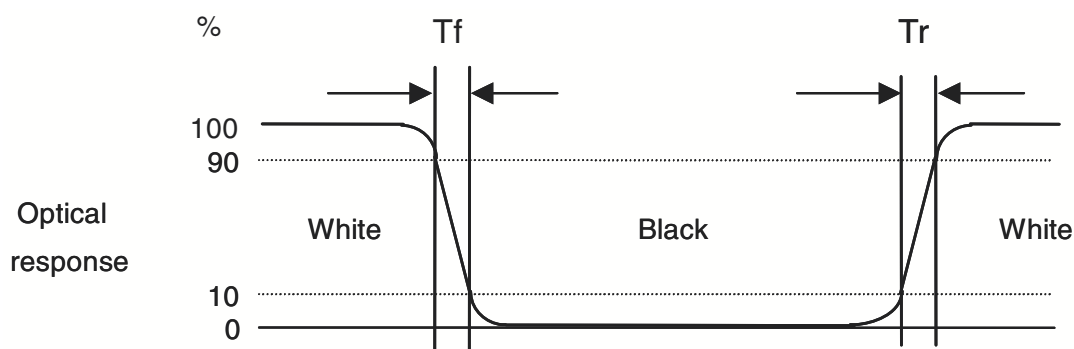

Appendix **B**

Handling Precautions

B.1 Handling Precautions

1. Because the front polarizer is vulnerable to damage, we recommend taking additional care not to scratch the polarizer surface.
2. Be sure to turn off the power supply when connecting/disconnecting from the input connector.
3. In the event of exposure to water or other liquids, immediately wipe off all liquid droplets. Prolonged contact with liquid may cause discoloration or spots.
4. To clean the panel surface, wipe with an absorbent cotton or soft cloth.
5. Because the panel is made of glass, it is liable to break or crack if dropped or hit with a hard object.
6. As CMOS LSI is used in this module, be cautious of static electricity and ensure human earthing when handling.
7. Do not open or modify the module assembly.
8. Do not bend the reflector sheet at the back of the module in any direction.
9. To reinsert the module into the packing container slot, lightly press the far edges of the LED light bar reflector; otherwise the TFT module may be damaged.
10. When inserting or removing the signal interface connector, do not rotate or tilt the interface connector on the TFT module.
11. After installing the TFT module in an enclosure, do not twist nor bend the TFT module. When designing such enclosures, avoid bending or twisting the TFT module to prevent damage.
12. A small amount of material with no flammability grading has been used in the LCD module. The LCD module should be supplied with power that satisfies the requirements of a limited power source (IEC60950 or UL1950); otherwise an exemption must be obtained.

ADVANTECH

Enabling an Intelligent Planet

www.advantech.com

Please verify specifications before quoting. This guide is intended for reference purposes only.

All product specifications are subject to change without notice.

No part of this publication may be reproduced in any form or by any means, electronic, photocopying, recording or otherwise, without prior written permission of the publisher.

All brand and product names are trademarks or registered trademarks of their respective companies.

© Advantech Co., Ltd. 2014

Free Manuals Download Website

<http://myh66.com>

<http://usermanuals.us>

<http://www.somanuals.com>

<http://www.4manuals.cc>

<http://www.manual-lib.com>

<http://www.404manual.com>

<http://www.luxmanual.com>

<http://aubethermostatmanual.com>

Golf course search by state

<http://golfingnear.com>

Email search by domain

<http://emailbydomain.com>

Auto manuals search

<http://auto.somanuals.com>

TV manuals search

<http://tv.somanuals.com>