



Use and Care Guide

JGAS02EK
JGAS02PK

Gas Ran

PUB#
49-4995

Contents

Anti-Tip Bracket	3, 5	Problem Solver	18
Appliance Registration	2	Repair Service	19
Care and Cleaning	14-17	Safety Instructions	2-5
Control Panel	14	Surface Cooking	7
Features	6	Air Adjustment	8
Flooring under the Range	5	Burners, Burner Grates	14, 15
Leveling	5	Control Settings	7
Lift-Up/Off Cooktop	14	Cookware Tips	8
Model and Serial Numbers	2	Flame Size	7
Oven	8, 9	Lighting Instructions	7
Air Adjustment	9	Warranty	Back Cover
Baking, Baking Guide	10, 11		
Broiling, Broiling Guide	13		
Control Settings	9		
Lighting Instructions	8, 9		
Oven Bottom Removal	16		
Preheating	10, 11		
Roasting, Roasting Guide	12		
Shelves	9, 15		
Thermostat Adjustment	16		
Vent Duct	9	GE Answer Center®	
Pilot Systems	5	800.626.2000	

Models JGAS02PK
JGAS02EK

GE Appliances

4-22-89

EFFDATE

01-09-89

49-4995

Help us help you...

Read this book carefully.

It is intended to help you operate and maintain your new range properly.

Keep it handy for answers to your questions.

If you don't understand something or need more help, write (include your phone number):

Consumer Affairs
GE Appliances
Appliance Park
Louisville, KY 40225

Write down the model and serial numbers.

You'll find them on a label located in the burner box under the cooktop.
See page 6.

These numbers are also on the Consumer Product Ownership Registration Card that came with your range. Before sending in this card, please write these numbers here:

Model Number

Serial Number

Use these numbers in any correspondence or service calls concerning your range.

If you received a damaged range...

Immediately contact the dealer (or builder) that sold you the range.

Save time and money. Before you request service...

Check the Problem Solver on page 18. It lists causes of minor operating problems that you can correct yourself.

FOR YOUR SAFETY

If you smell gas:

1. Open windows.
2. Don't touch electrical switches.*
3. Extinguish any open flame.
4. Immediately call your gas supplier.

*Don't turn electric switches on or off because sparks may ignite the gas.

FOR YOUR SAFETY

Do not store or use gasoline or other flammable vapors and liquids in the vicinity of this or any other appliance.

IMPORTANT SAFETY INSTRUCTIONS

Read all instructions before using this appliance.

IMPORTANT SAFETY NOTICE

The California Safe Drinking Water and Toxic Enforcement Act requires the Governor of California to publish a list of substances known to the state to cause cancer and requires businesses to warn customers of potential exposure to such substances.

Gas appliances can cause minor exposure to three of these substances, namely benzene, formaldehyde and soot, caused primarily by the incomplete combustion of natural gas or LP fuels. Properly adjusted ranges, indicated by a bluish rather than a yellow flame, will minimize incomplete combustion. Exposure to these substances can be minimized further by venting with an open window or using a ventilation fan or hood.

When You Get Your Range

- Have the installer show you the location of the range gas cut-off valve and how to shut it off if necessary.
- Have your range installed and properly grounded by a qualified installer, in accordance with the Installation Instructions. Any adjustment and service should be performed only by qualified gas range installers or service technicians.

- If your range has electric ignition, plug it into a 120-volt grounded outlet only. Do not remove the round grounding prong from the plug. If in doubt about the grounding of the home electrical system, it is your personal responsibility and obligation to have an ungrounded outlet replaced with a properly-grounded three-prong outlet in accordance with the National Electrical Code. Do not use an extension cord with this appliance.

- Be sure all packing materials are removed from the range before operating it, to prevent fire or smoke damage should the packing material ignite.

- Locate range out of kitchen traffic path and out of drafty locations to prevent pilot outage (on model so equipped) and poor air circulation.

- Be sure your range is correctly adjusted by a qualified service technician or installer for the type of gas (Natural or LP) on which it is to be used. Your range can be converted for use on either type of gas. See Installation Instructions.

- After prolonged use of a range, high floor temperatures may result and many floor coverings will not withstand this kind of use. Never install the range over vinyl tile or linoleum that cannot withstand such type of use. Never install it directly over interior kitchen carpeting.

Using Your Range

- Don't leave children alone or unattended where a range is hot or in operation. They could be seriously burned.

- Don't allow anyone to climb, stand or hang on the door, broiler compartment or range top. They could damage the range and even tip it over causing severe personal injury.

- **CAUTION: ITEMS OF INTEREST TO CHILDREN SHOULD NOT BE STORED IN CABINETS ABOVE A RANGE OR ON THE BACKSPASH OF A RANGE—CHILDREN CLIMBING ON THE RANGE TO REACH ITEMS COULD BE SERIOUSLY INJURED.**

WARNING—All ranges

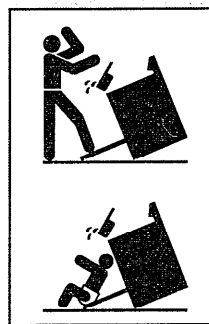

can tip and injury could result. To prevent accidental tipping of the range, attach it to the wall or floor by installing the

ANTI-TIP bracket supplied. To check if the bracket is installed and engaged properly, carefully tip the range forward to check if the ANTI-TIP bracket is engaged with the leveling leg.

If you pull the range out from the wall for any reason, make sure the rear leg is returned to its position in the bracket when you push the range back.

- Let burner grates and other surfaces cool before touching them or leaving them where children can reach them.

- Never wear loose fitting or hanging garments while using the appliance. Flammable material could be ignited if brought in contact with flame or hot oven surfaces and may cause severe burns.

- Never use your appliance for warming or heating the room. Prolonged use of the range without adequate ventilation can be hazardous.

- Do not use water on grease fires. Never pick up a flaming pan. Turn off burner, then smother flaming pan by covering pan completely with well fitting lid, cookie sheet or flat tray. Flaming grease outside a pan can be put out by covering with baking soda or, if available, a multi-purpose dry chemical or foam type fire extinguisher.

- Do not store flammable materials in an oven or near the cooktop.

- Do not let cooking grease or other flammable materials accumulate in or near the range.

- When cooking pork, follow the directions exactly and always cook the meat to an internal temperature of at least 170°F. This assures that, in the remote possibility that trichina may be present in the meat, it will be killed and meat will be safe to eat.

Surface Cooking

- Always use the LITE position when igniting top burners and make sure the burners have ignited.

- Never leave surface burners unattended at HI flame settings. Boilover causes smoking and greasy spillovers that may catch on fire.

- Adjust top burner flame size so it does not extend beyond the edge of the cooking utensil. Excessive flame is hazardous.

(continued next page)

IMPORTANT SAFETY INSTRUCTIONS (continued)

- **Use only dry pot holders**—moist or damp pot holders on hot surfaces may result in burns from steam. Do not let pot holders come near open flames when lifting utensils. Do not use a towel or other bulky cloth in place of a pot holder.
- **To minimize the possibility of burns**, ignition of flammable materials, and spillage, turn the cookware handles toward the side or back of the range without extending over adjacent burner.
- **Always turn surface burner to OFF before removing utensil.**
- **Carefully watch foods being fried at HI flame setting.**
- **Never block the vents (air openings) of the range.** They provide the air inlet and outlet which is necessary for the range to operate properly with correct combustion.
- **Do not use a wok on the cooking surface if the wok has a round metal ring which is placed over the burner grate to support the wok.** This ring acts as a heat trap which may damage the burner grate and burner head. Also, it may cause the burner to work improperly. This may cause a carbon monoxide level above current standards, resulting in a health hazard.
- **Foods for frying should be as dry as possible.** Frost on frozen foods or moisture on fresh foods can cause hot fat to bubble up and over sides of pan.
- **Use least possible amount of fat for effective shallow or deep-fat frying.** Filling the pan too full of fat can cause spillovers when food is added.
- **Always heat fat slowly, and watch as it heats.**
- **If a combination of oils or fats will be used in frying**, stir together before heating, or as fats melt slowly.
- **Use deep fat thermometer whenever possible** to prevent overheating fat beyond the smoking point.
- **Use proper pan size**—Avoid pans that are unstable or easily tipped. Select utensils having flat bottoms large enough to properly contain food avoiding boilovers and spillovers, but large enough to cover burner grate. This will both save cleaning and prevent hazardous accumulations of food, since heavy spattering or spillovers left on range can ignite. Use pans with handles that can be easily grasped and remain cool.
- **Use only glass cookware that is recommended** for use on gas burners.
- **Keep all plastics away from top burners.**
- **To avoid the possibility of a burn**, always be certain that the controls for all burners are at **OFF position and all grates are cool before attempting to remove the grate.**
- **When flaming foods under the hood, turn the fan off.** The fan, if operating, may spread the flame.
- **If range is located near a window**, do not use long curtains which could blow over the top burners and create a fire hazard.
- **When a pilot goes out**, (on model so equipped), you will detect a faint odor of gas as your signal to relight pilot. When relighting pilot, make sure burner controls are in OFF position and follow instructions described on following pages to relight.
- **If you smell gas**, and you have already made sure pilots are lit, turn off the gas to the range and call a qualified service technician. Never use an open flame to locate a leak.

Baking, Broiling and Roasting

- **Do not use oven for a storage area.**
- **Stand away from the range when opening the door of a hot oven.** The hot air or steam which escapes can cause burns to hands, face and/or eyes.
- **Keep oven free from grease buildup.**
- **Pulling out shelf to the shelf stop is a convenience in lifting heavy foods.** It is also a precaution against burns from touching hot surfaces of the door or oven walls.
- **Don't heat unopened food containers in the oven.** Pressure could build up and the container could burst causing an injury.
- **Don't use aluminum foil anywhere in the oven except as described in this book.** Misuse could result in a fire hazard or damage to the range.
- **When using cooking or roasting bags in oven**, follow the manufacturer's direction.
- **Use only glass cookware that is recommended** for use in gas ovens.
- **Always remove broiler pan from broiler compartment as soon as you finish broiling.** Grease left in the pan can catch fire if oven is used without removing the grease from the broiler pan.

Pilot Systems

- When broiling, if meat is too close to the flame, the fat may ignite. Trim excess fat to prevent excessive flare-ups.

- Make sure broiler pan is in place correctly to reduce the possibility of grease fires.

- If you should have a grease fire in the broiler pan, turn off oven, and keep drawer closed to contain fire until it burns out.

Cleaning Your Range

- Clean only parts listed in this Use and Care Book.

- Keep range clean and free of accumulations of grease or spillovers which may ignite.

If You Need Service

- Read "The Problem Solver" on page 18 of this book.

- Don't attempt to repair or replace any part of your range unless it is specifically recommended in this book. All other servicing should be referred to a qualified technician.

**SAVE THESE
INSTRUCTIONS**

Your gas range is equipped with either a Standing Pilot or Electric Pilot Ignition System.

Model JGAS02PK

Standing Pilot System has a continuous flame burning at all times.

Model JGAS02EK

Electric Pilot Ignition System uses an electric spark to ignite the burners and does not require use of a match unless electrical current to your range is interrupted.

Flooring under the Range

Your range, like so many other household items, is heavy and can settle into soft floor coverings such as cushioned vinyl. When moving the range on this type of flooring, use care.

Do not install the range over kitchen carpeting unless you place an insulating pad or sheet of 1/4-inch-thick plywood between the range and carpeting.

When the floor covering ends at the front of the range, the area that the range will rest on should be built up with plywood or similar material to the same level or higher than the floor covering. This will allow the range to be moved for cleaning or servicing.

Leveling the Range

Leveling legs are located on each corner of the base of the range.

Your range must be level in order to produce proper cooking and baking results. After it is in its final location, place a level horizontally on an oven shelf and check the levelness front to back and side to side. Level the range by adjusting the leveling legs or by placing shims under the corners as needed.

One of the rear leveling legs will engage the ANTI-TIP bracket (allow for some side to side adjustment). Allow a minimum clearance of 1/8" between the range and the leveling leg that is to be installed into the ANTI-TIP bracket.

Features of Your Range

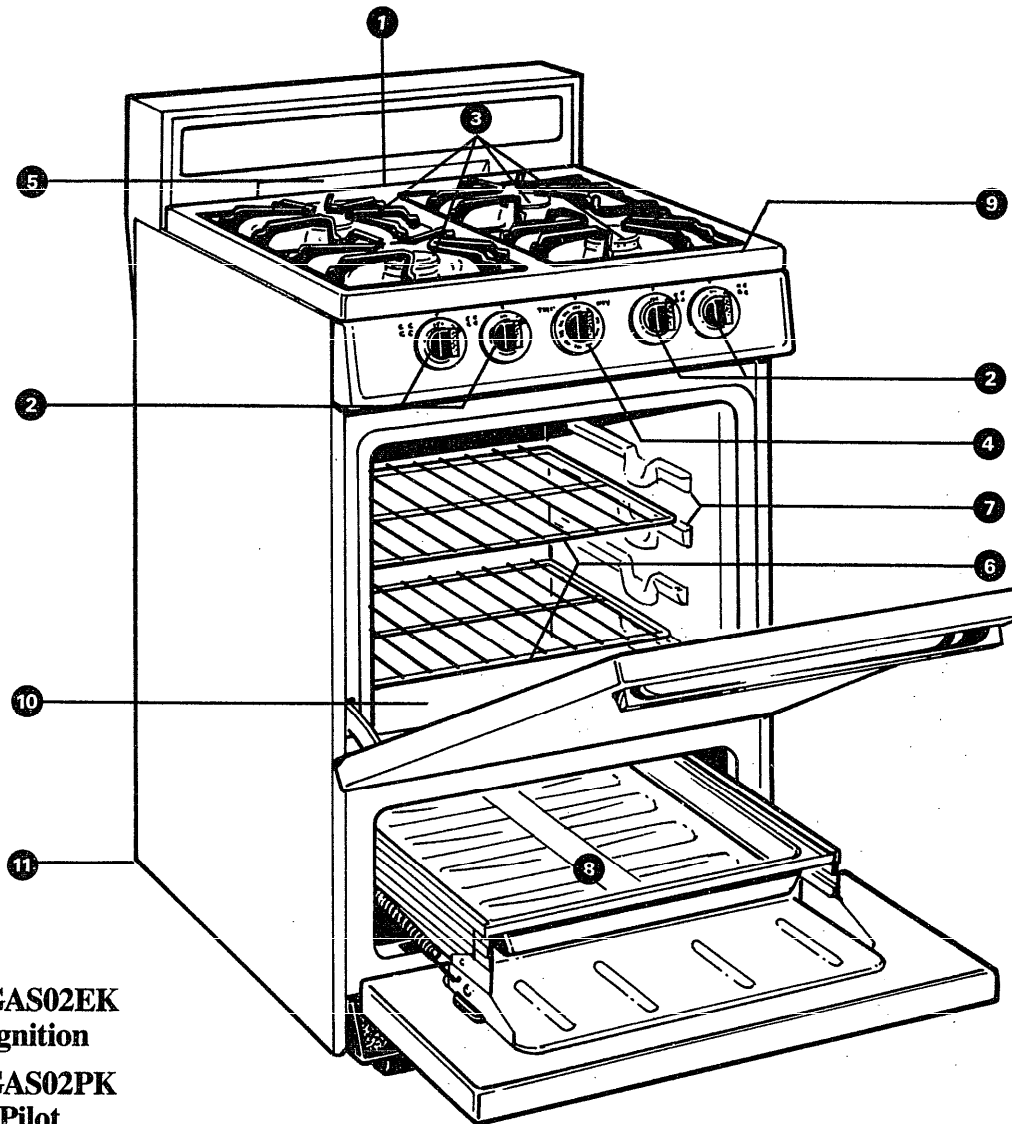

Model JGAS02EK
Electric Ignition
Model JGAS02PK
Standing Pilot

Feature Index	Explained on page
1 Model and Serial Numbers (in burner box under cooktop)	2
2 Surface Burner Controls	7
3 Surface Burners and Grates	14, 15, 17
4 OVEN TEMP Knob	9
5 Oven Vent (located in center of rear of range)	9

Feature Index	Explained on page
6 Oven Shelves (easily removed or repositioned on shelf supports)	9, 15
7 Oven Shelf Supports	9
8 Broiler Pan and Rack	13, 15, 17
9 Lift-Up/Off Cooktop	14
10 Removable Oven Bottom	16
11 Anti-Tip Bracket (see Safety Instructions)	3, 5

Surface Cooking

Lighting Instructions

Standing Pilot Model JGAS02PK

The surface burners on your range have standing surface burner pilots that must be lit initially. To light them:

1. Be sure surface burner control knobs are in the OFF position.
2. Remove the grates and lift the cooktop up or off (see page 14).

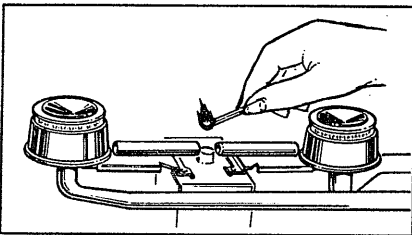

3. Locate the two pilot ports and light each of them with a match.

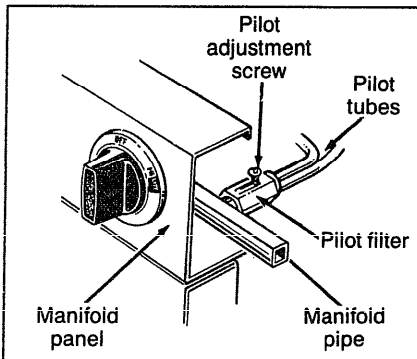

4. If the pilots need adjusting, turn the adjusting screw located on the pilot filter.
5. Lower the cooktop.

Electric Ignition Model JGAS02EK

Surface burners on your range are lighted by electric ignition, ending the need for standing pilot lights with constantly burning flames.

In case of a power outage, you can light the pilotless ignition surface burners on your range with a match. Hold a lighted match to the burner, then turn the knob to the LITE position. **To avoid getting burned, use extreme caution when lighting burners this way.**

Surface Burner Controls

The knobs that turn the surface burners on and off are located on the control panel on the front of the range.

The two on the left control the left front and left rear burners. The two on the right control the right front and right rear burners.

To Light a Surface Burner

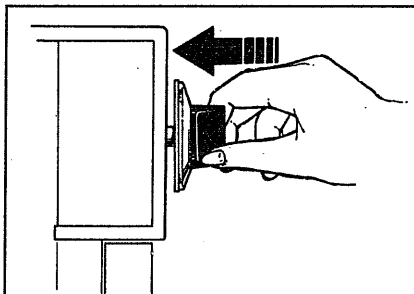

Push the control knob in and turn it to LITE. On electric ignition models, you will hear a little clicking noise—the sound of the electric ignition spark that lights the burner.

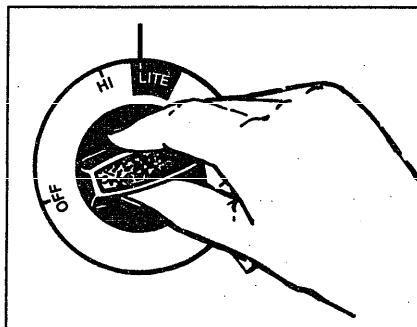

After the burner ignites, turn the knob to adjust the flame size.

Note:

- Always have a pan on the grate before turning on a burner. The finish on the grate may chip without a pan to absorb the heat.
- Check to be sure the burner you turned on is the one you want to use.
- Be sure the burners and grates are cool before you place your hand, a potholder, cleaning cloths or other materials on them.

How to Select Flame Size

The flame size on a gas burner should match the cookware you are using.

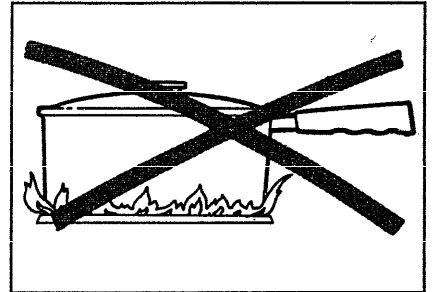

NEVER LET THE FLAME EXTEND UP THE SIDES OF THE COOKWARE. Any flame larger than the bottom of the cookware is wasted and only serves to heat the handles.

When using aluminum or aluminum-clad stainless steel pots and pans, adjust the flame so the circle it makes is about 1/2 inch smaller than the bottom of the cookware.

When boiling, use this same flame size—1/2 inch smaller than the bottom of the cookware—no matter what the cookware is made of. Foods cook just as quickly at a gentle boil as they do at a furious rolling boil. A high boil cooks away moisture, flavor and nutrition. Avoid it except for the few cooking processes which need a vigorous boil.

When frying or warming foods in stainless steel, cast iron or enamelware, keep the flame down lower—to about 1/2 the diameter of the pan.

When frying in glass or ceramic cookware, lower the flame even more.

Surface Cooking (continued)

Air Adjustment

An air adjustment shutter for each surface burner regulates the flow of air to the flame.

When the right amount of air flows into the burner, the flame will be steady, relatively quiet and have approximately 3/4" sharp blue cones. This is usually the case with factory preset shutter settings.

With too much air, the flame will be unsteady, possibly won't burn all the way around, and will be noisy, sounding like a blowtorch.

With not enough air, you won't see any sharp blue cones in the flame, you may see yellow tips, and soot may accumulate on pots and pans.

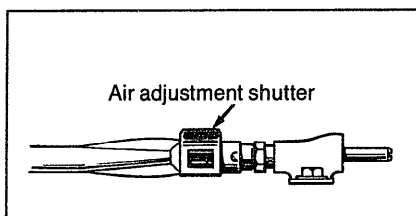

To adjust the flow of air to the burners, rotate the shutters to allow more or less air into the burner tubes as needed.

Top-of-Range Cookware

Aluminum: Medium-weight cookware is recommended because it heats quickly and evenly. Most foods brown evenly in an aluminum skillet. Minerals in food and water will stain but will not harm aluminum. A quick scour with a soap-filled wool pad after each use keeps aluminum cookware looking shiny new. Use saucepans with tight-fitting lids for cooking with minimum amounts of water.

Cast Iron: If heated slowly, most skillets will give satisfactory results.

Enamelware: Under some conditions, the enamel of some cookware may melt. Follow cookware manufacturer's recommendations for cooking methods.

Glass: There are two types of glass cookware—those for oven use only and those for top-of-range cooking (saucepans, coffee and teapots). Glass conducts heat very slowly.

Heatproof Glass Ceramic: Can be used for either surface or oven cooking. It conducts heat very slowly and cools very slowly. Check cookware manufacturer's directions to be sure it can be used on gas ranges.

Stainless Steel: This metal alone has poor heating properties, and is usually combined with copper, aluminum or other metals for improved heat distribution. Combination metal skillets generally work satisfactorily if used at medium heat as the manufacturer recommends.

Using Your Oven

Lighting Instructions

Standing Pilot Model JGAS02PK

Your oven burner has a standing pilot port that must be lit initially. To light it:

1. Be sure OVEN TEMP knob is in the OFF position.
2. Remove the oven bottom (see page 16) and the burner baffle.

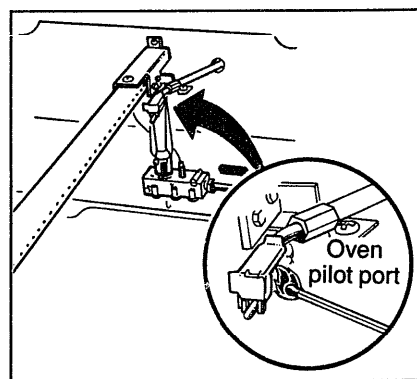

3. Locate the pilot port on the side of the burner at the back of the oven. Using a long match or match holder, reach in and light the oven pilot.
4. Replace the burner baffle and oven bottom and close the door. Your oven and broiler are now ready for use.

Power outage?

An electrical power failure will not affect a lighted standing oven pilot.

Electric Ignition Model JGAS02EK

The oven burner on this range is lighted by electric ignition. The oven and broiler cannot be operated in the event of a power failure.

To light the oven burner, turn the OVEN TEMP knob to the desired temperature. The burner should ignite within 60 seconds.

Power outage?

A burner in use when an electrical power failure occurs will continue to operate normally. Your oven may be used during an electrical power outage by carefully following the steps below:

To light the oven pilot during an electrical power outage:

1. Be sure OVEN TEMP knob is in the OFF position.
2. Open both the oven and broiler doors and wait 5 minutes to allow any pilot gas to dissipate.
3. Unplug the range from the wall outlet, turn off the circuit breaker, or remove the fuse to avoid accidental ignition of the oven if electric power is restored while you are lighting the pilot.
4. Remove the broiler pan.
5. Locate the oven pilot assembly by looking into the broiler opening. The pilot is at the back of the broiler compartment, on the right side of the burner.

Note: The oven must be at room temperature before you should attempt to light the oven pilot manually.

6. Turn the OVEN TEMP knob to the desired temperature setting.
7. Light the pilot with a match and withdraw your arm immediately because the oven burner may light in as little as 20 seconds.
8. Replace the broiler pan and close the oven and broiler doors.

Note: It is necessary to light the pilot manually each time the oven is used during a power outage.

Air Adjustment

An air adjustment shutter for the oven burner regulates the flow of air to the flame. You'll find the shutter against the back wall behind the broiler drawer. To reach it, remove the oven bottom (page 16) and the burner baffle.

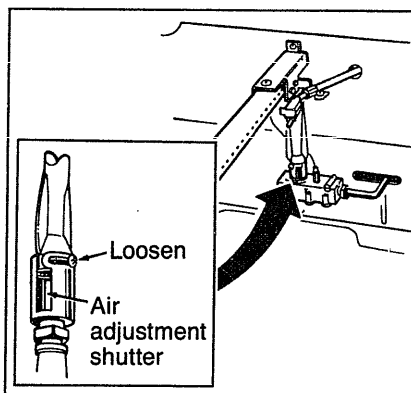

To adjust the flow of air, loosen the Phillips head screw and rotate the shutter to allow more or less air into the burner tube as needed.

When the right amount of air flows into the burner, the flame should be steady, with approximately 1/2" blue cones, and should not extend out over the baffle edges.

Oven Temperature Control

The OVEN TEMP control is located at the center of the control panel on the front of the range.

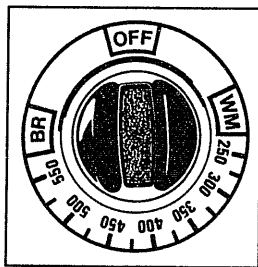

Simply turn the knob to the desired cooking temperatures, which are marked in 25°F. increments on the dial. It will normally take 30 to 60 seconds before the flame comes on.

After the oven reaches the selected temperature, the oven burner cycles—off completely, then on with a full flame—to keep the oven temperature controlled.

Oven Shelves

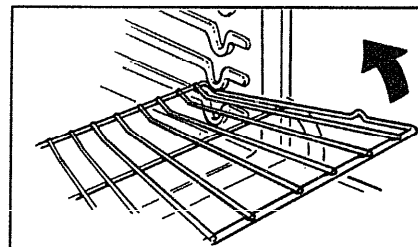

The shelves are designed with stop-locks so when placed correctly on the shelf supports, they will stop before coming completely out of the oven and will not tilt when you are removing food from them or placing food on them.

When placing cookware on a shelf, pull the shelf out to the "stop" position. Place the cookware on the shelf, then slide the shelf back into the oven. This will eliminate reaching into the hot oven.

To remove the shelves from the oven, pull them toward you, tilt front end upward and pull them out.

To replace, place shelf on shelf support with stop-locks (curved extension under shelf) facing up and toward rear of oven. Tilt up front and push shelf toward back of oven until it goes past "stop" on oven wall. Then lower front of shelf and push it all the way back.

Shelf Positions

The oven has four shelf supports—A (bottom), B, C and D (top). Shelf positions for cooking are suggested on Baking and Roasting pages.

Oven Vent

Your oven is vented through a duct at the rear of the range. Do not block the opening of this duct—it is important that the flow of hot air from the oven and fresh air to the oven burner be uninterrupted. Avoid touching the vent openings or nearby surfaces during oven or broiler operations—they may be hot.

Baking

How to Set Your Range for Baking

1. Position the shelf or shelves in the oven.
2. Close oven door, turn OVEN TEMP knob to desired temperature and preheat oven for at least 15 minutes if preheating is necessary.
3. Place food in oven on center of shelf. Allow at least 2 inches between edge of bakeware and oven wall or adjacent cookware.
If cooking on two shelves at the same time, place shelves about 4 inches apart and stagger food on them.
4. Check food for doneness at minimum time on recipe. Cook longer if necessary. Switch off heat and remove food.

Preheating

Preheating is important when using temperatures below 225°F. and when baking foods such as biscuits, cookies, cakes and other pastries.

Preheating is not necessary when roasting or for long-time cooking of whole meals.

Shelf Positions

Most baking is done on the second shelf position (B) from the bottom.

When baking three or four items, use two shelves positioned on the second and fourth sets of supports (B & D) from bottom of oven.

Bake angel food cakes on first shelf position (A) from bottom of oven.

Baking Tips

- Follow a tested recipe and measure the ingredients carefully. If you are using a package mix, follow label directions.
- If moisture is noticeable on the front of the oven (or on the oven window or black glass door on models so equipped) when first

turning on the oven, leave the oven door ajar for a few minutes or until the oven is warm.

- Do not open the oven door during a baking operation—heat will be lost and the baking time might need to be extended. This could cause poor baking results. If you must open the door, open it partially—only 3 or 4 inches—and close it as quickly as possible.
- Do not disturb the heat circulation in the oven with the use of aluminum foil. If foil is used, place a small sheet of it, about 10 by 12 inches at the most, on a lower shelf several inches below the food. Do not place foil on the oven bottom.

Common Baking Problems and Possible Solutions

PIES

Burning around edges

- Oven too full; avoid overcrowding.
- Edges of crust too thin.
- Incorrect baking temperature.

Bottom crust soggy and unbaked

- Allow crust and/or filling to cool sufficiently before filling pie shell.
- Filling may be too thin or juicy.
- Filling allowed to stand in pie shell before baking. (Fill pie shells and bake immediately.)
- Ingredients and proper measuring affect the quality of the crust. Use a tested recipe and good technique. Make sure there are no tiny holes or tears in a bottom crust. "Patching" a pie crust could cause soaking.

Pie filling runs over

- Top and bottom crust not well sealed together.
- Edges of pie crust not built up high enough.
- Too much filling.
- Check size of pie plate.

Pastry is tough; crust not flaky

- Too much handling.
 - Fat too soft or cut in too fine.
- Roll dough lightly and handle as little as possible.

CAKES

Cake rises higher on one side

- Batter spread unevenly in pan.
- Range not level.
- Using warped pans.
- Incorrect pan size.

Cakes cracking on top

- Oven temperature too high.
- Batter too thick, follow recipe or exact package directions.
- Check for proper shelf position.
- Check pan size called for in recipe.
- Improper mixing of cake.

Cake falls

- Too much shortening, sugar or liquid.
- Check leavening agent, baking powder or baking soda to assure freshness. Make a habit to note expiration dates of packaged ingredients.
- Cake not baked long enough or at incorrect temperature.
- If adding oil to a cake mix, make certain the oil is the type and amount specified.

Crust is hard

- Check temperature.
- Check shelf position.

Cake has soggy layer or streaks at bottom

- Undermixing ingredients.
- Shortening too soft for proper creaming.
- Too much liquid.

COOKIES & BISCUITS

Doughy center; heavy crust on surface

- Check temperature.
- Check shelf position.
- Follow baking instructions carefully as given in reliable recipe or on convenience food package.
- Flat cookie sheets will give more even baking results. Don't overcrowd foods on a baking sheet.
- Convenience foods used beyond their expiration date.

Browning more noticeable on one side

- Oven door not closed properly, check gasket seal.
- Check shelf position.

Baking Guide

1. Preheating is very important when using temperatures below 225°F. and when baking foods such as biscuits, cookies, cakes and other pastries. Preheat the oven for at least 15 minutes.

Preheating is not necessary when roasting or for long-time cooking of whole meals.

2. Aluminum pans conduct heat quickly. For most conventional baking, light, shiny finishes give best results because they help prevent overbrowning. For best browning results, we recommend dull bottom surfaces for cake pans and pie plates.

3. Dark or non-shiny finishes, also glass and Pyroceram® cookware, generally absorb heat which may result in dry, crisp crusts. Reduce oven heat 25°F. if lighter crusts are desired. Rapid browning of some foods can be achieved by preheating cast iron cookware.

Food	Cookware	Shelf Positions	Oven Temperatures	Time, Minutes	Comments
Bread					
Biscuits (½-in. thick)	Shiny Cookie Sheet	B, C	400°-475°	15-20	Canned, refrigerated biscuits take 2 to 4 minutes less time.
Coffee cake	Shiny Metal Pan with satin-finish bottom	B, A	350°-400°	20-30	
Conn. bread or muffins	Cast Iron or Glass Pan	B	400°-450°	20-40	Preheat cast iron pan for crisp crust.
Gingerbread	Shiny Metal Pan with satin-finish bottom	B	350°	45-55	
Muffins	Shiny Metal Muffin Pans	A, B	400°-425°	20-30	Decrease about 5 minutes for muffin mix.
Popovers	Deep Glass or Cast Iron Cups	B	375°	45-60	Or bake at 450°F. for 25 minutes, then at 350°F. for 10 to 15 minutes.
Quick loaf bread	Metal or Glass Loaf Pans	B	350°-375°	45-60	Dark metal or glass gives deepest browning.
Yeast bread (2 loaves)	Metal or Glass Loaf Pans	A, B	375°-425°	45-60	
Plain rolls	Shiny Oblong or Muffin Pans	A, B	375°-425°	10-25	For thin rolls, Shelf B may be used.
Sweet rolls	Shiny Oblong or Muffin Pans	B, A	350°-375°	20-30	For thin rolls, Shelf B may be used.
Cakes (without shortening)					
Angel food	Aluminum Tube Pan	A	325°-375°	30-55	Two piece pan is convenient.
Jelly roll	Metal Jelly Roll Pan	B	375°-400°	10-15	Line pan with waxed paper.
Sponge	Metal or Ceramic Pan	A	325°-350°	45-60	
Cakes					
Bundt cakes	Metal or Ceramic Pan	A, B	325°-350°	45-65	
Cupcakes	Shiny Metal Muffin Pans	B	350°-375°	20-25	Paper liners produce more moist crusts.
Fruitcakes	Metal or Glass Loaf or Tube Pan	A, B	275°-300°	2-4 hrs.	Use 300°F. and Shelf B for small or individual cakes.
Layer	Shiny Metal Pan with satin-finish bottom	B	350°-375°	20-35	If baking four layers use shelves B and D.
Layer, chocolate	Shiny Metal Pan with satin-finish bottom	B	350°-375°	25-30	
Loaf	Metal or Glass Loaf Pans	B	350°	40-60	
Cookies					
Brownies	Metal or Glass Pans	B, C	325°-350°	25-35	Bar cookies from mix use same time.
Drop	Cookie Sheet	B, C	350°-400°	10-20	Use Shelf C and increase temperature 25 to 50°F. for more browning.
Refrigerator	Cookie Sheet	B, C	400°-425°	6-12	
Rolled or sliced	Cookie Sheet	B, C	375°-400°	7-12	
Fruits, Other Desserts					
Baked apples	Glass or Metal Pans	A, B, C	350°-400°	30-60	
Custard	Glass Custard Cups or Casserole (set in pan of hot water)	B	300°-350°	30-60	Reduce temperature to 300°F. for large custard.
Puddings, rice and custard	Glass Custard Cups or Casserole	B	325°	50-90	Cook bread or rice pudding with custard base 80 to 90 minutes.
Pies					
Frozen	Foil Pan on Cookie Sheet	A	400°-425°	45-70	Large pies use 400°F. and increase time.
Meringue	Spread to crust edges	B	325°-350°	15-25	To quickly brown meringue use 400°F. for 9 to 11 minutes.
One crust	Glass or Satin-finish Metal Pan	A, B	400°-425°	45-60	Custard fillings require lower temperature, longer time.
Two crust	Glass or Satin-finish Metal Pan	B	400°-425°	40-60	
Pastry shell	Glass or Satin-finish Metal Pan	B	450°	13-16	
Miscellaneous					
Baked potatoes	Set on Oven Shelf	A, B, C	325°-400°	60-90	Increase time for large amount or size.
Scalloped dishes	Glass or Metal Pan	A, B, C	325°-375°	30-60	
Souffles	Glass Pan	B	300°-350°	30-75	

Roasting

Roasting is cooking by dry heat. Tender meat or poultry can be roasted uncovered in your oven. Roasting temperatures, which should be low and steady, keep spattering to a minimum. When roasting, it is not necessary to sear, baste, cover, or add water to your meat. Roasting is easy, just follow these steps:

Step 1: Position oven shelf at second from bottom position (B) for small size roast (3 to 5 lbs.) and at bottom position (A) for larger roasts.

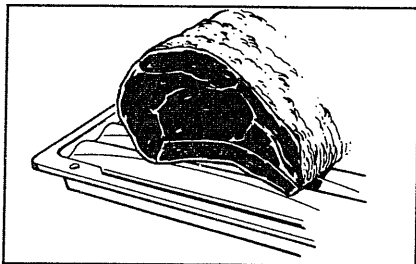

Step 2: Check weight of roast. Place meat fat-side-up or poultry breast-side-up on roasting rack in a shallow pan. The melting fat will baste the meat. Select a pan as close to the size of meat as possible. (Broiler pan with rack is a good pan for this.)

Step 3: Turn OVEN TEMP control to desired temperature. Check the Roasting Guide for temperatures and approximate cooking times.

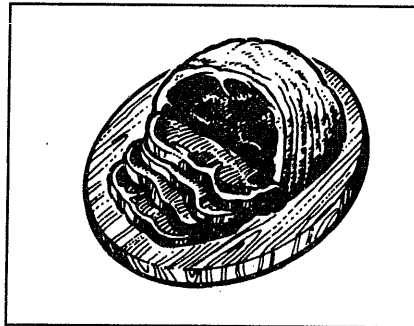

Step 4: Most meats continue to cook slightly while standing after being removed from the oven. For rare or medium internal doneness, you may wish to remove meat from the oven just before it is done if it is to stand 10 to 20 minutes while you make gravy or attend to other foods. If no standing is planned, cook meat to suggested temperature.

Frozen Roasts

Frozen roasts of beef, pork, lamb, etc., can be started without thawing, but allow 10 to 25 minutes per pound additional time (10 minutes per pound for roasts under 5 pounds, more time for larger roasts).

Thaw most frozen poultry before roasting to ensure even doneness. Some commercial frozen poultry can be cooked successfully without thawing. Follow directions given on packer's label.

Roasting Guide

Type	Oven Temperature	Doneness	Approximate Roasting Time in Minutes per Pound		Internal Temperature °F
Meat			3 to 5-lbs.	6 to 8-lbs.	
Tender cuts; rib, high quality sirloin tip, rump or top round*	325°	Rare: Medium: Well Done:	24-30 30-35 35-45	18-22 22-25 28-33	130°-140° 150°-160° 170°-185°
Lamb leg or bone-in shoulder*	325°	Rare: Medium: Well Done:	21-25 25-30 30-35	20-23 24-28 28-33	130°-140° 150°-160° 170°-185°
Veal shoulder, leg or loin*	325°	Well Done:	35-45	30-40	170°-180°
Pork loin, rib or shoulder*	325°	Well Done:	35-45	30-40	170°-180°
Ham, pre-cooked	325°	To Warm:	10 minutes per lb. (any weight)		125°-130°
Ham, raw	325°	Well Done:	Under 10 lbs. 20-30	10 to 15-lbs. 17-20	170°
*For boneless rolled roasts over 6-inches thick, add 5 to 10 minutes per lb. to times given above.					
Poultry			3 to 5-lbs.	Over 5 lbs.	
Chicken or Duck	325°	Well Done:	35-40	30-35	185°-190°
Chicken pieces	375°	Well Done:	35-40		185°-190°
Turkey	325°	Well Done:	10 to 15-lbs. 20-25	Over 15 lbs. 15-20	In thigh: 185°-190°

Broiling

Broiling is cooking food by direct heat from above the food. Your range has a convenient compartment below the oven for broiling. It also has a specially designed broiler pan and rack that allow dripping fat to drain away from the foods and be kept away from the high heat of the gas flame.

Distance from the heat source may be changed by positioning the broiler pan and rack on one of three shelf positions in the broiler compartment—A (bottom of broiler compartment), B (middle) and C (top).

Both the oven and broiler compartment doors should be closed during broiling.

How to Broil

1. If meat has fat or gristle near the edge, cut vertical slashes through it about 2 inches apart, but don't cut into meat. We recommend that you trim fat to prevent excessive smoking, leaving a layer about 1/8-inch thick.
2. Remove broiler pan and rack from broiler compartment and place food on rack.
3. Pull out drawer and position broiler pan in compartment. Placing food closer to flame increases exterior browning of food, but also increases spattering and the possibility of fats and meat juices igniting.
4. Close broiler door and, for most foods, turn OVEN TEMP knob to BROIL. Exceptions are chicken and ham which are broiled at a lower setting in order to cook food through without over-browning it.
5. Turn most foods once during cooking; (the exception is thin fillets of fish; oil one side, place that side down on broiler rack and cook without turning until done). Time foods for about one-half the total cooking time, turn food, then continue to cook to preferred doneness.
6. Turn OVEN TEMP knob to OFF. Remove broiler pan from compartment, using hot pad, and serve food immediately. Leave pan outside compartment to cool.

Broiling Tips

• Use tongs to turn meat over—pierced meat loses juices.

• Steaks and chops should be at least 1-inch thick for best broiling results. Pan broil thinner ones.

Broiling Guide

Food	Quantity and/or Thickness	Broil Position	1st Side Time, Minutes	2nd Side Time, Minutes	Comments
Bacon	½-lb. (about 8 thin slices)	B	3½	3½	Arrange in single layer.
Ground Beef	1-lb. (4 patties)	A	6-8	5	Space evenly. Up to 8 patties take about the same time.
Medium Rare	½ to ¾-in. thick	A	6-9	4-6	
Medium		A	7-10	6-7	
Well Done		A			
Beef Steaks					Steaks less than 1-inch cook through before browning. Pan frying is recommended. Trim off excess fat.
Rare	1-in. thick	A	6	3-5	
Medium	(1-1 ½ lbs.)	A	7	4-5	
Well Done		A	9	6-7	
Rare	1½-in. thick	A	8	4-6	
Medium	(2-2 ½ lbs.)	A	9	8-10	
Well Done		A	11	8-12	
Chicken (450°)	1 whole (2 to 2 ½-lbs.), split lengthwise	A	30-35	25-30	Reduce times about 5 to 10 minutes per side for cut-up chicken. Brush each side with melted butter. Broil with skin side down first and broil with door closed.
Bakery Products					Space evenly. Place English muffins cut-side-up and brush with butter, if desired.
Bread (Toast) or Toaster Pastries	2-4 slices	B	½-1	½	
1 pkg. (2)					
English Muffins	2-split	B	2-3		
Lobster tails (6 to 8-oz. each)	2-4	A	10-14	Do not turn over.	Cut through back of shell, spread open. Brush with melted butter before and after half time.
Fish	1-lb. fillets ¼ to ½-in. thick	A	5	5	Handle and turn very carefully. Brush with lemon butter before and during cooking, if desired. Preheat broiler to increase browning.
Ham slices (450°) Precooked	1-in. thick	B	8	8	Increase times 5 to 10 min. per side for 1½-inch thick or home cured.
Pork chops	2 (½ in.)	A	10	4-5	Trim off excess fat.
Well Done	2 (1-in. thick), about 1 lb.	A	13	10-12	
Lamb chops					Trim off excess fat.
Medium	2 (1 in.)	B	8	4-7	
Well Done	about 10-12 oz.	B	10	10	
Medium	2 (1½ in.),	B	10	4-6	
Well Done	about 1 lb.	B	17	12-14	
Wieners, similar precooked sausages, bratwurst	1-lb. pkg. (10)	B	6	1-2	If desired, split sausages in half lengthwise; cut into 5 to 6-inch pieces.

Care and Cleaning

Proper care and cleaning are important so your range will give you efficient and satisfactory service. Follow these directions carefully in caring for it to help assure safe and proper maintenance.

IF YOUR RANGE HAS ELECTRIC IGNITION, BE SURE ELECTRIC POWER IS OFF BEFORE CLEANING ANY PART OF IT.

Enamel Finish

When the range is cool, wash the enamel finish with mild soap and water or a mild abrasive cleanser applied with a damp cloth. Rinse the surface with clean water and dry with a soft cloth. If you wish, occasionally apply a thin coat of mild cleaning wax to help protect the finish.

There are a number of precautions you can take to avoid marring the surface of the range and to prevent it from becoming dull. Don't slide heavy pans across it. If you spill foods with a lot of acid (tomatoes, sauerkraut, fruit juices, etc.) or foods with high sugar content, clean them up as soon as possible. If allowed to set, these foods could cause a dull spot. Also, no matter how stubborn the food stain, never use harsh abrasive cleansers. They could permanently damage the enamel surface.

Control Panel

It's a good idea to wipe the control panel clean after each use of the oven. For a more thorough cleaning, the knobs can be removed by pulling them off the knob stems. Clean with mild soap and water, rinse with clean water and polish dry with a soft cloth.

Do not use abrasive cleansers, strong liquid cleaners or oven cleaners on the control panel as they will damage the finish.

Burner Grates

Grates should be washed regularly and, of course, after spillovers. Wash them in hot, soapy water and rinse with clean water. Dry the grates with a cloth—don't put them back on the range wet. When replacing the grates, be sure they're locked into position over the burners.

To get rid of burned-on food, soak the grates in a slightly diluted liquid cleanser.

Although they're durable, the grates will gradually lose their shine, regardless of the best care you can give them. This is due to their continual exposure to high temperatures.

Do not operate a burner for an extended period of time without cookware on the grate. The finish on the grate may chip without cookware to absorb the heat.

When replacing a pair of grates, the irregular sides should meet in the middle as shown at right.

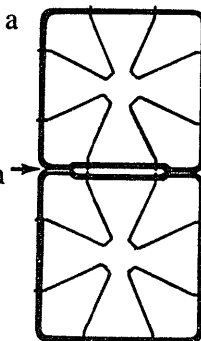

Lift-Up/Off Cooktop

Clean the area under the cooktop often. Built-up soil, especially grease, may catch fire.

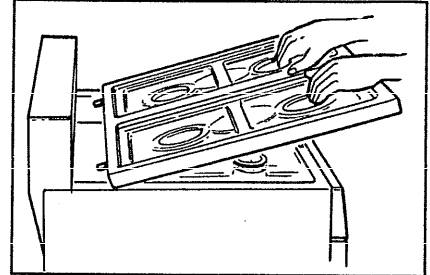

To make cleaning easier, the cooktop may be lifted up or off.

Be sure all burners are turned off before raising the cooktop. Then remove the grates. Grasp the two front burner wells and lift the cooktop up or off. Be careful of the pilots when the cooktop is up.

After cleaning underneath the cooktop with hot, soapy water and a clean cloth, lower or replace the cooktop. Be careful not to pinch your fingers.

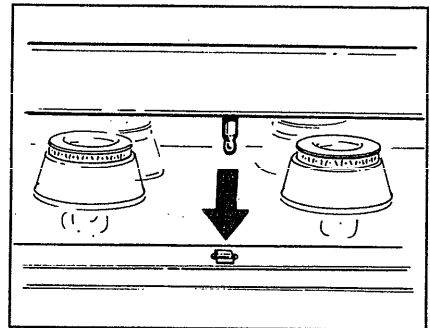

To replace the cooktop if you have removed it, insert the two tabs at the back of the cooktop into slots at the base of the backguard. Lower cooktop into place, applying pressure until tab on underside snaps into catch at top front center of range.

Range Top Burners

The holes in the burners of your range must be kept clean at all times for proper ignition and an even, unhampered flame.

You should clean the burners routinely and especially after bad spillovers which could clog these holes. Burners lift right out for cleaning.

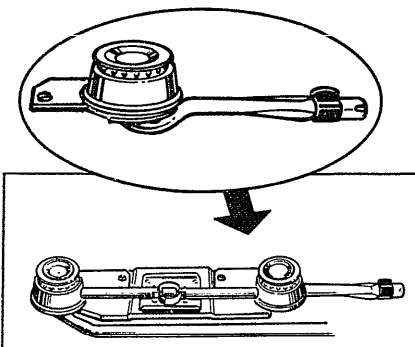

Note: A screw holds each of the burners in place to keep them from wobbling around during shipment. Remove and discard the shipping screw. Tilt the burner to one side at the end closest to the ignitor and move it toward the back of the range. This disengages it from the gas valve at the front of the range, and it lifts out easily.

To remove burned-on food, soak the burner in a solution of a product used for cleaning the inside of coffee makers. Soak the burner for 20 to 30 minutes. If the food doesn't rinse off completely, scrub it with soap and water or a mild abrasive cleanser and a damp cloth.

Before putting the burner back, dry it thoroughly by setting it in a warm oven for 30 minutes. Then place it back in the range, making sure it is properly seated and level.

Oven Shelves

Oven shelves may be cleaned with a mild abrasive cleanser following manufacturer's directions. After cleaning, rinse the shelves with clean water and dry with a dry cloth. To remove heavy, burned-on soil, soapy metal pads may be used following manufacturer's directions. After scrubbing, wash with soapy water, rinse and dry.

Broiler Pan & Rack

After broiling, remove the broiler rack and carefully pour off the grease. Wash and rinse the rack in hot, soapy water.

If food has burned on, sprinkle the rack while hot with detergent and cover with wet paper towels or a dish cloth. That way, burned-on foods will soak loose while the meal is being served.

Do not store a soiled broiler pan and rack in the oven or broiler compartment.

Broiler Drawer

To remove: When broiler is cool, remove rack and pan.

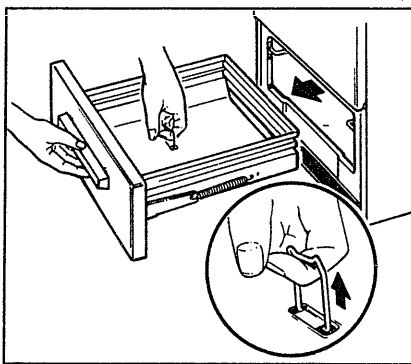

Then, with drawer out about halfway, pull metal clip located in center of drawer bottom upward as far as it will go (about 2 inches). The drawer can now be pulled all the way out of the compartment.

To replace: Slide grooves at top of drawer onto guide rails at sides of broiler compartment and push drawer in to close.

Porcelain Oven Interior

With proper care, the porcelain enamel interior will retain its good-looking finish for many years.

Soap and water will normally do the job. Heavy spattering or spillovers may require cleaning with a mild abrasive cleanser. Soapy, wet pads may also be used. Do not allow food spills with a high sugar or acid content (such as milk, tomatoes, sauerkraut, fruit juices or pie filling) to remain on the surface. They may cause a dull spot even after cleaning.

Household ammonia may make the cleaning job easier. Place 1/2 cup in a shallow glass or pottery container in a cold oven overnight. The ammonia fumes will help loosen the burned-on grease and food.

If necessary, you may use a caustic cleaner. Follow the package directions.

Cautions about using spray-on oven cleaners:

Be careful where the oven cleaner is sprayed.

- **Do not** spray on the electrical controls and switches (on models so equipped) because it could cause a short circuit and result in sparking or fire.

- **Do not** allow a film from the cleaner to build up on the temperature sensing bulb—it could cause the oven to heat improperly. (The bulb is located at the top of the oven.) Carefully wipe the bulb clean after each oven cleaning, being careful not to move the bulb as a change in its position could affect how the oven bakes.

- **Do not** spray any oven cleaner on the oven door, handles or any exterior surface of the oven, wood or painted surfaces. The cleaner can damage these surfaces.

Care and Cleaning (continued)

Removable Oven Bottom

The oven bottom can be removed to make cleaning easier.

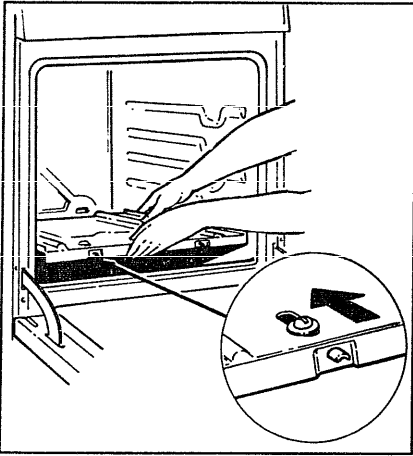

To remove:

When oven is cool, remove oven shelves. Loosen (but do not remove) two screws at front of oven bottom. Slide screws back to release front of oven bottom. Lift the oven bottom up and pull forward until rear tabs release from rear oven wall. Then take oven bottom out of oven.

To replace:

Insert two tabs into slots in rear oven wall. Lower bottom into place. Slide two screws at front of oven bottom forward and tighten them to secure oven bottom in place. Note: If the oven bottom is replaced incorrectly, it may warp and cause undesirable baking results.

The oven bottom has a porcelain enamel finish. To make cleaning easier, protect the oven bottom from excessive spillovers. This is particularly important when baking a fruit pie or other foods with high acid content. Hot fruit fillings or foods that are acid in content such as milk, tomato or sauerkraut, and sauces with vinegar or lemon juice, may cause pitting and damage to the porcelain enamel surface.

To protect the oven bottom surface, place a piece of aluminum foil slightly larger than the baking dish or a small cookie sheet on a lower shelf or under the baking dish to catch any boilovers. It should not completely cover the shelf as this would cause uneven heat in the oven. Aluminum foil should not be placed on the oven bottom.

If a spillover does occur on the oven bottom allow the oven to cool first. You can clean the bottom with soap and water, a mild abrasive cleanser, soap-filled abrasive pads or caustic oven cleaner following manufacturer's directions.

Adjusting Oven Thermostat

The temperature control in your new oven has been carefully adjusted to provide accurate temperatures. However, if this oven has replaced one you have used for several years, you may notice a difference in the degree of browning or the length of time required when using your favorite recipes. Oven temperature controls have a tendency to "drift" over a period of years and since this drift is very gradual, it is not readily noticed. Therefore, you may have become accustomed to your previous oven which may have provided a higher or lower temperature than you selected.

Before attempting to have the temperature of your new oven changed, be sure you have followed the baking time and temperature of the recipe carefully. Then, after you have used the oven a few times and you feel the oven is too hot or too cool, there is a simple adjustment you can make yourself on the OVEN TEMP knob.

Pull the knob off the control shaft and look at the back side. There is a disc in the center of the knob skirt with a series of marks opposite a pointer.

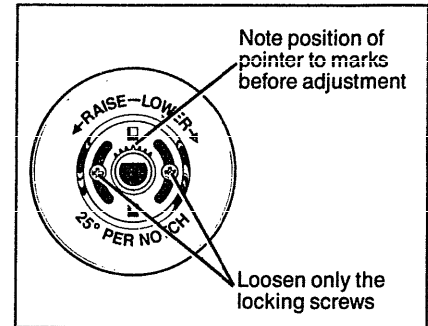

Note to which mark the pointer is pointing. To make an adjustment, carefully loosen (approximately one turn), but do not completely remove the two screws that hold the skirt to the knob. Hold the knob blade in one hand and the outer skirt in the other hand.

To raise the oven temperature, move the pointer in the direction of the arrow for RAISE. To lower the temperature, move the pointer in the direction of arrow for LOWER. Each mark will change the oven temperature approximately 25°F.

We suggest that you make the adjustment one mark from the original setting and check oven performance before making any additional adjustments.

After the adjustment is made, press skirt and knob together and retighten screws so they are snug, but be careful not to overtighten. Re-install knob on range and check performance.

Note: After an adjustment has been made, the OFF and BROIL positions will not line up with the indicator mark on the control panel as they previously did. This condition is normal and will not create a problem.

Cleaning Guide

Note: Let range/oven parts cool before touching or handling.

PART	MATERIALS TO USE	GENERAL DIRECTIONS
Broiler Pan and Rack	<ul style="list-style-type: none"> • Soap and Water • Soap-Filled Scouring Pad • Commercial Oven Cleaner 	Drain fat, cool pan and rack slightly. (Do not let soiled pan and rack stand in broiler compartment to cool.) Sprinkle detergent on rack and pan. Fill the pan with warm water and spread cloth or paper towel over the rack. Let pan and rack stand for a few minutes. Wash; scour if necessary. Rinse and dry. OPTION: The broiler pan and rack may also be cleaned in a dishwasher.
Control Knobs	<ul style="list-style-type: none"> • Mild Soap and Water 	Pull off knobs. Wash gently but do not soak. Dry and return controls to range making sure to match flat area on the knob and shaft.
Metal	<ul style="list-style-type: none"> • Soap and Water 	Wash, rinse, and then polish with a dry cloth. DO NOT USE steel wool, abrasives, ammonia, acids, or commercial oven cleaners which may damage the finish.
Outer Porcelain Enamel Finish	<ul style="list-style-type: none"> • Paper Towel • Dry Cloth • Soap and Water 	Avoid cleaning powders or harsh abrasives which may scratch the enamel. If acids should spill on the range while it is hot, use a dry paper towel or cloth to wipe up right away. When the surface has cooled, wash and rinse. For other spills, such as fat splatterings, etc., wash with soap and water when cooled and then rinse. Polish with dry cloth.
Painted Surfaces	<ul style="list-style-type: none"> • Soap and Water 	Use a mild solution of soap and water. Do not use any harsh abrasives or cleaning powders which may scratch or mar surface.
Oven Liner*	<ul style="list-style-type: none"> • Soap and Water • Soap-Filled Scouring Pad • Commercial Oven Cleaner 	<p>Cool before cleaning.</p> <p>FOR LIGHT SOIL: Frequent wiping with mild soap and water (especially after cooking meat) will prolong the time between major cleaning. Rinse thoroughly. NOTE: Soap left on liner causes additional stains when oven is reheated.</p> <p>FOR HEAVY SOIL: Choose a non-abrasive cleaner and follow label instructions, using thin layer of cleaner. Use of rubber gloves is recommended. Wipe or rub lightly on stubborn spots. Rinse well. Wipe off any oven cleaner that gets on thermostat bulb. When rinsing oven after cleaning also wipe thermostat bulb.</p>
Inside Oven Door*	<ul style="list-style-type: none"> • Soap and Water • Soap-Filled Scouring Pad • Commercial Oven Cleaner 	Use the same directions for cleaning as given above for Oven Liner.
Removable Oven Bottom	<ul style="list-style-type: none"> • Soap and Water • Soap-Filled Scouring Pad (Non-metallic) 	The oven bottom panel can be removed for easy cleaning. Use the same directions for cleaning as given above for Oven Liner.
Surface Burner Grates	<ul style="list-style-type: none"> • Soap and Water • Soap-Filled Scouring Pad (Non-metallic) 	Lift out when cool. Soak 5 to 10 minutes if desired in warm solution of dishwasher detergent. Scour with materials mentioned here to remove burned-on food particles.
Burners	<ul style="list-style-type: none"> • Solution for Cleaning Inside of Coffee Makers • Soap and Water • Mild Abrasive Cleanser • Damp Cloth 	Wipe off burner heads. If heavy spillover occurs, remove burners from range (see page 15) and soak them for 20 to 30 minutes in solution of hot water and product for cleaning inside of coffee makers, such as Dip-It brand. If soil does not rinse off completely, scrub burners with soap and water or a mild abrasive cleanser and a damp cloth. Dry burners in a warm oven for 30 minutes before returning them to the range.
Shelves	<ul style="list-style-type: none"> • Soap and Water • Soap-Filled Scouring Pad • Commercial Oven Cleaner 	Your shelves can be cleaned by using any and all mentioned materials. Rinse thoroughly to remove all materials after cleaning. NOTE: Some commercial oven cleaners cause darkening and discoloration. When using for first time, test cleaner on small part of shelf and check for discoloration before completely cleaning.

*Spillage of marinades, fruit juices, and basting materials containing acids may cause discoloration. Spillovers should be wiped up immediately, with care being taken not to touch any hot portion of the oven. When the surface is cool, clean and rinse.



Questions? Use This Problem Solver

PROBLEM	POSSIBLE CAUSE AND/OR WHAT TO DO
TOP BURNERS DO NOT LIGHT	<ul style="list-style-type: none">• Pilots are not lit. Lift or remove cooktop and hold lighted match next to pilot opening between front and rear burners. On models with electric ignition, make sure electrical plug is plugged into a live power outlet.• Burner holes on side of burner may be clogged. Remove and clean them.• Burners may not be fitted correctly onto the mounting brackets. Remove and reinstall the burners properly.
OVEN DOES NOT COOK PROPERLY	<ul style="list-style-type: none">• Make sure thermostat capillary bulb (located in upper portion of oven) is in correct position, is not touching oven sides and is not coated with anything.• Aluminum foil being used improperly in oven.• Oven vent blocked on back of range.• Incorrect cookware being used. Check each cooking section for cookware tips or recommendations.• Oven bottom not securely seated in position.• OVEN TEMP knob set incorrectly or not turned on.• Check baking, roasting and broiling instructions on pages 10-13.

If you need more help...call, toll free:
GE Answer Center®
800.626.2000
consumer information service

If You Need Service

To obtain service, see your warranty on the back page of this book.

We're proud of our service and want you to be pleased. If for some reason you are not happy with the service you receive, here are three steps to follow for further help.

FIRST, contact the people who serviced your appliance. Explain why you are not pleased. In most cases, this will solve the problem.

NEXT, if you are still not pleased, write all the details—including your phone number—to:

Manager, Consumer Relations
GE Appliances
Appliance Park
Louisville, Kentucky 40225

FINALLY, if your problem is still not resolved, write:

Major Appliance
Consumer Action Panel
20 North Wacker Drive
Chicago, Illinois 60606

YOUR GENERAL ELECTRIC RANGE WARRANTY

Save proof of original purchase date such as your sales slip or cancelled check to establish warranty period.

WHAT IS COVERED

FULL ONE-YEAR WARRANTY

For one year from date of original purchase, we will provide, free of charge, parts and service labor in your home to repair or replace **any part of the range** that fails because of a manufacturing defect.

This warranty is extended to the original purchaser and any succeeding owner for products purchased for ordinary home use in the 48 mainland states, Hawaii and Washington, D.C. In Alaska the warranty is the same except that it is **LIMITED** because you must pay to ship the product to the service shop or for the service technician's travel costs to your home.

All warranty service will be provided by our Factory Service Centers or by our authorized Customer Care® servicers during normal working hours.

Look in the White or Yellow Pages of your telephone directory for **GENERAL ELECTRIC COMPANY, GENERAL ELECTRIC FACTORY SERVICE, GENERAL ELECTRIC-HOTPOINT FACTORY SERVICE** or **GENERAL ELECTRIC CUSTOMER CARE® SERVICE**.

WHAT IS NOT COVERED

- Service trips to your home to teach you how to use the product.

Read your Use and Care material.

If you then have any questions about operating the product, please contact your dealer or our Consumer Affairs office at the address below, or call, toll free: **GE Answer Center®**
800.626.2000
consumer information service

- Improper installation.

If you have an installation problem, contact your dealer or installer. You are responsible for providing adequate electrical, gas, exhausting and other connecting facilities.

- Replacement of house fuses or resetting of circuit breakers.

- Failure of the product if it is used for other than its intended purpose or used commercially.

- Damage to product caused by accident, fire, floods or acts of God.

WARRANTOR IS NOT RESPONSIBLE FOR CONSEQUENTIAL DAMAGES.

Some states do not allow the exclusion or limitation of incidental or consequential damages, so the above limitation or exclusion may not apply to you. This warranty gives you specific legal rights, and you may also have other rights which vary from state to state. To know what your legal rights are in your state, consult your local or state consumer affairs office or your state's Attorney General.

Warrantor: General Electric Company

**If further help is needed concerning this warranty, write:
Manager—Consumer Affairs, GE Appliances, Louisville, KY 40225**

Part No. 164D1352P227

Pub No. 49-4995

9110P130-60

Free Manuals Download Website

<http://myh66.com>

<http://usermanuals.us>

<http://www.somanuals.com>

<http://www.4manuals.cc>

<http://www.manual-lib.com>

<http://www.404manual.com>

<http://www.luxmanual.com>

<http://aubethermostatmanual.com>

Golf course search by state

<http://golfingnear.com>

Email search by domain

<http://emailbydomain.com>

Auto manuals search

<http://auto.somanuals.com>

TV manuals search

<http://tv.somanuals.com>