

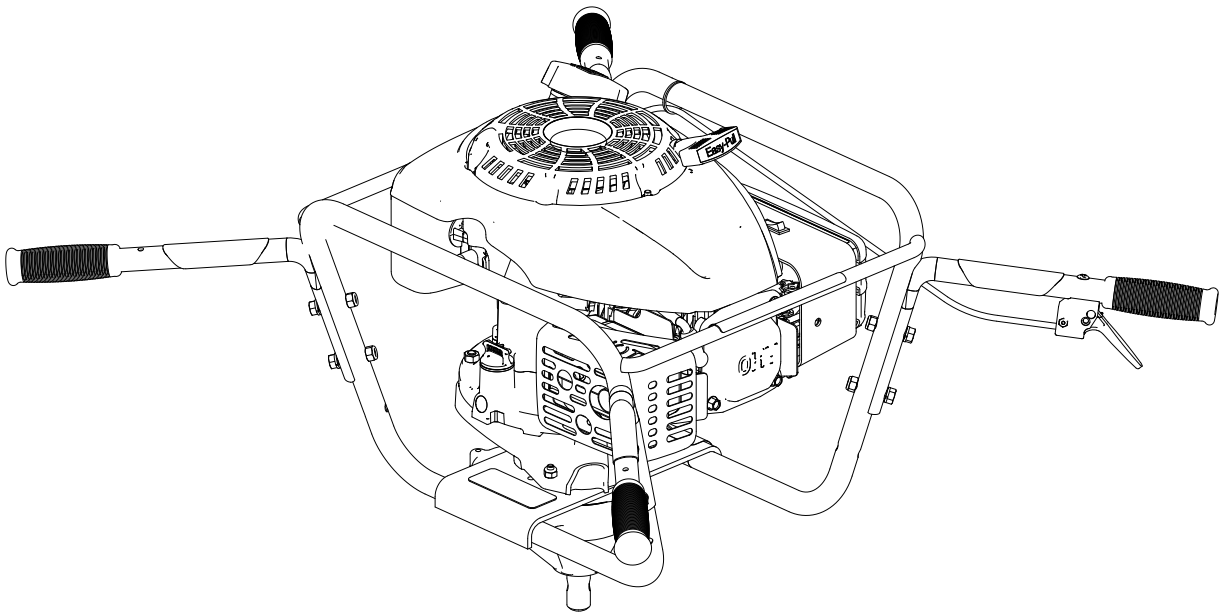

Operator's Manual
Original Operating Instructions

Two-Man Earth Auger Powerhead 9800 Series

SN



Includes Model:

9800K

Get parts online at
www.GetEarthquake.com



P/N: 22914
ECN: 11558
REV1: 03/10/17
© 2017 Ardisam, Inc.
All Rights Reserved

INTRODUCTION

Thank you for purchasing an Earthquake™ 9800K Powerhead. We have worked to ensure that this powerhead meets the highest standards for usability and durability. With proper care, your powerhead will provide many years of service.

Please read this entire manual before installation and use. Earthquake® reserves the right to change, alter or improve the product and this document at any time without prior notice.

CONTENTS

Introduction/Content/Registration and Service	2
Warnings and Safety Precautions.....	3-6
Operation Precautions/Maintenance and Storage Precautions.....	6
Burns and Fires/Safety Decals.....	6-7
Features	8
Unpacking and Assembly	9
Operation	9-10
Maintenance and Storage.....	10-12
Troubleshooting and Repair.....	12-13
Illustrated Parts Breakdown.....	14-17
Warranty	18

REGISTRATION AND SERVICE

Record the product model number and serial number in the space provided for easy reference when ordering parts or requesting technical support. Excluding emissions-related warranty items, the warranty is valid only if the completed registration is received by Ardisam within 30 days of purchase. (SEE WARRANTY SECTION FOR MORE INFORMATION) You can register your warranty online by visiting www.earthquake.com, or by mailing it to: Ardisam Inc, 1160 8th Avenue, Cumberland, WI 54829. You may also call our Customer Service department at (800) 345-6007 Mondays through Fridays from 8 a.m. to 5 p.m. CST.

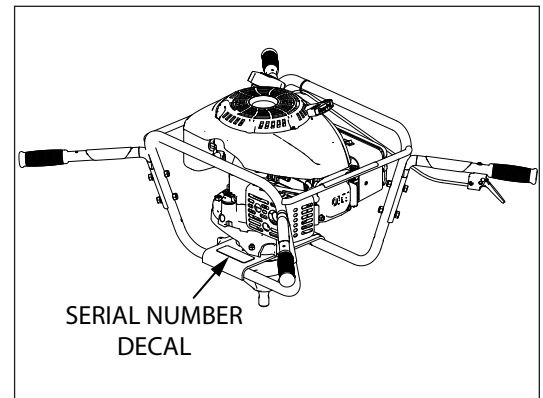

OWNERSHIP RECORDS		
Owner's Name:		
Owner's Address:		
City:	State/Province:	Zip Code/Postal Code:
Model Number:	Serial Number:	
Date of Purchase:		
Notes:		

Read and keep this manual for future reference. This manual contains important information on SAFETY, ASSEMBLY, OPERATION, AND MAINTENANCE. The owner must be certain that all the product information is included with the unit. This information includes the MANUAL, the REPLACEMENT PARTS and the WARRANTIES. This information must be included to make sure state laws and other laws are followed. All persons to whom rent/loan this unit must have access to and understand this information. This manual should remain with the product even if it is resold.

WARNINGS AND SAFETY PRECAUTIONS

Owner's Responsibility

Accurate assembly and safe and effective use of the machine is the owner's responsibility.

- Read and follow all safety instructions.
- Carefully follow all assembly instructions.
- Maintain the machine according to directions and schedule included in this *Earthquake* operator's manual.
- Ensure that anyone who uses the machine is familiar with all controls and safety precautions.

Special Messages

Your manual contains special messages to bring attention to potential safety concerns, machine damage as well as helpful operating and servicing information. Please read all the information carefully to avoid injury and machine damage.

NOTE: *General information is given throughout the manual that may help the operator in the operation or service of the machine.*

THIS SYMBOL POINTS OUT IMPORTANT SAFETY INSTRUCTIONS WHICH, IF NOT FOLLOWED, COULD ENDANGER YOUR PERSONAL SAFETY. READ AND FOLLOW ALL INSTRUCTIONS IN THIS MANUAL BEFORE ATTEMPTING TO OPERATE THIS EQUIPMENT.



Before Operating Engine:

Please read this section carefully. Read entire operating and maintenance instructions for this product. Failure to follow instructions could result in damage to personal property, serious injury or death. Operate the machine according to the safety instructions outlined here and inserted throughout the text. Anyone who uses this machine must read the instructions and be familiar with the controls.

Intended Use / Foreseeable Misuse

IMPORTANT: This is a motorized earth auger powerhead that drills into soil. It is pedestrian-controlled with a gasoline-fueled internal combustion engine to power the auger blades. It shall not be used for any other purpose.

NOTICE

NOTICE INDICATES YOUR EQUIPMENT CAN BE DAMAGED IF THE SAFETY INSTRUCTIONS THAT FOLLOW THIS SIGNAL WORD ARE NOT OBEYED.

CAUTION

CAUTION INDICATES A HAZARD WHICH, IF NOT AVOIDED, COULD RESULT IN PERSONAL INJURY AND/OR PROPERTY DAMAGE.

WARNING

WARNING INDICATES A HAZARD WHICH, IF NOT AVOIDED, COULD RESULT IN DEATH OR SERIOUS INJURY AND/OR PROPERTY DAMAGE.

DANGER

DANGER INDICATES A HAZARD WHICH, IF NOT AVOIDED, WILL CERTAINLY RESULT IN DEATH OR SERIOUS INJURY AND/OR PROPERTY DAMAGE.

IMPORTANT

IMPORTANT INDICATES HELPFUL INFORMATION FOR PROPER ASSEMBLY, OPERATION, OR MAINTENANCE OF YOUR EQUIPMENT.

WARNING

CALIFORNIA PROPOSITION 65 WARNING

ENGINE EXHAUST FROM THIS PRODUCT CONTAINS CHEMICALS KNOWN TO THE STATE OF CALIFORNIA TO CAUSE CANCER, BIRTH DEFECTS, OR OTHER REPRODUCTIVE HARM.

WARNING

YOU MUST READ, UNDERSTAND AND COMPLY WITH ALL SAFETY AND OPERATING INSTRUCTIONS IN THIS MANUAL BEFORE ATTEMPTING TO SETUP AND OPERATE YOUR MACHINE.

FAILURE TO COMPLY WITH ALL SAFETY AND OPERATING INSTRUCTIONS CAN RESULT IN LOSS OF MACHINE CONTROL, SERIOUS PERSONAL INJURY TO YOU AND/OR BYSTANDERS, AND RISK OF EQUIPMENT AND PROPERTY DAMAGE. THE TRIANGLE IN THE TEXT SIGNIFIES IMPORTANT CAUTIONS OR WARNINGS WHICH MUST BE FOLLOWED.

General Safety Rules

- Read, understand, and follow all instructions on the machine and in the manual(s). Be thoroughly familiar with the controls and the proper use of the machine before starting.
- Use this equipment for its intended purpose only.
- Familiarize yourself with all of the safety and operating decals on this equipment and on any of its attachments or accessories.
- Do not put hands or feet near or under rotating parts.
- Only allow responsible individuals who are familiar with the instructions to operate the machine. Do not allow children to operate this machine. Do not allow adults to operate the machine without proper instruction.
- Thoroughly inspect the area where the machine is to be used and remove all foreign objects. Your equipment can propel small objects at high speed causing personal injury or property damage. Stay away from breakable objects, such as house windows, automobile, greenhouses, etc.
- Wear appropriate clothing such as a long-sleeved shirt or jacket. Also wear long trousers or slacks. Do not wear shorts. Never wear sandals, sneakers, or open shoes, and never operate the machine with bare feet.
- Do not wear loose clothing or jewelry. They can get caught in moving parts. Always keep hands, feet, hair and loose clothing away from any moving parts on engine and machine.
- Always wear safety goggles or safety glasses with side shields when operating the machine to protect your eyes from foreign objects which can be thrown from the unit. Always wear a protective hearing device.
- Always wear work gloves and sturdy footwear. Wear footwear that will improve footing on slippery surfaces. Leather work shoes or short boots work well for most people. These will protect the operator's ankles and shins from small sticks, splinters, and other debris.
- It is advisable to wear protective headgear to prevent the possibility of being struck by small flying particles, or being struck by low hanging branches, twigs, or other objects which may be unnoticed by the operator.
- Do not operate the machine without proper guards or other safety protective devices in place.
- See manufacturer's instructions for proper operation and installation of accessories. Only use accessories approved by the manufacturer.
- Operate only in daylight or good artificial light.
- Do not operate product when fatigued or under the influence of alcohol, drugs or other medication which can cause drowsiness or affect your ability to operate this machine safely.
- Never operate machine in wet grass. Always be sure of your footing; keep a firm hold on the handle and walk; never run.
- Watch for traffic when operating near, or when crossing roads.
- If the equipment should start to vibrate abnormally, stop the engine (motor), disconnect the spark plug wire and prevent it from touching the spark plug. Check immediately for cause. Vibration is generally a warning of trouble. If the noise or vibrations of the machine increase, stop immediately and perform an inspection.
- Never leave the machine unattended when the engine is running. Remove the wire from the spark plug.
- Regularly inspect the machine. Make sure parts are not bent, damaged or loose.
- Temperature of muffler and nearby areas may exceed 150° F (65° C). Allow muffler and engine areas to cool before touching. Never pick up or carry the machine while the engine is running.
- Prolonged exposure to noise and vibration from gasoline engine-powered equipment should be avoided. Take intermittent breaks and/or wear ear protection from engine noise as well as heavy work gloves to reduce vibration in the hands.
- Keep all screws, nuts and bolts tight.
- Do not transport the machine from one place to another with the engine running.
- When moving the packaged machine, always do so with a partner.
- Check local regulations for age restrictions on use of this machine.

Product-Specific Safety Rules

- This product is intended for use by two operators only. Never attempt to use powerhead with only one operator as serious injury may occur.
- Do not drill above underground utilities, including water lines, gas lines, electric cables, or pipes. Do not operate the machine in terrain/soil with large rocks and foreign objects which can damage the equipment.
- After striking a foreign object, stop the engine. Remove the wire from the spark plug. Inspect the powerhead and auger for damage. If damaged, repair before starting and operating the machine.
- The auger should not rotate when the engine is idling. If it does rotate when engine is idling, contact *Earthquake* for instructions.
- If an object becomes lodged in the auger, turn engine off, remove the wire from the spark plug and secure, allow to cool before attempting to remove the foreign object.
- The earth blade is very sharp. Use extreme caution when drilling a hole or replacing the blade.
- Do not carry the earth auger unit between holes with the engine running.

⚠ DANGER

ENGINES GIVE OFF CARBON MONOXIDE, AN ODORLESS, COLORLESS, POISONOUS GAS. CARBON MONOXIDE MAY BE PRESENT EVEN IF YOU DO NOT SMELL OR SEE ANY ENGINE EXHAUST. BREATHING CARBON MONOXIDE CAN CAUSE NAUSEA, FAINTING OR DEATH, IN ADDITION TO DROWSINESS, DIZZINESS AND CONFUSION.

IF YOU EXPERIENCE ANY OF THESE SYMPTOMS, SEEK FRESH AIR AND MEDICAL ATTENTION IMMEDIATELY.

⚠ CAUTION

HOT GASES ARE A NORMAL BY-PRODUCT OF A FUNCTIONING INTERNAL COMBUSTION ENGINE. FOLLOW ALL SAFETY INSTRUCTIONS TO PREVENT BURNS AND FIRES.

⚠ WARNING

NEVER ALTER OR MODIFY THE ENGINE FROM THE FACTORY. SERIOUS INJURY OR DEATH MAY OCCUR IF ENGINE IS MODIFIED OR ALTERED.

WHEN WORKING ON OR REPLACING PARTS FOR THE ENGINE OR PRODUCT, YOU MUST ALWAYS FLIP THE ON/OFF SWITCH TO THE OFF POSITION.

Engine Safety Precautions

If your product comes with a separate engine manual, be sure to read and follow all safety and warning precautions outlined there, in addition to any in this manual.

Preventing Carbon Monoxide Poisoning

- Always start and run engine outdoors. Do not start or run engine in an enclosed area, even if doors or windows are open.
- Never try to ventilate engine exhaust indoors. Carbon monoxide can reach dangerous levels very quickly.
- Never run engine outdoors where exhaust fumes may be pulled into a building.
- Never run engine outdoors in a poorly ventilated area where the exhaust fumes may be trapped and not easily taken away. (Examples include: in a large hole or areas where hills surround your working area.)
- Never run engine in an enclosed or partially enclosed area. (Examples include: buildings that are enclosed on one or more sides, under tents, car ports or basements.)
- Always run the engine with the exhaust and muffler pointed in the direction away from the operator.
- Never point the exhaust muffler towards anyone. People should always be many feet away from the operation of the engine and its attachments.
- Do not change the engine governor settings or over-speed the engine.

Gasoline Fires and Handling Fuel Safely

Use extra care in handling gasoline and other fuels. They are flammable and vapors are explosive.

- When storing extra fuel be sure that it is in an appropriate container and away from any fire hazards.
- Prevent fire and explosion caused by static electric discharge. Use only nonmetal, portable fuel containers approved by the Underwriter's Laboratory (U.L.) or the American Society for Testing & Materials (ASTM).
- Never remove the fuel cap or add fuel with the engine running. Stop engine and allow to cool before filling.
- Never drain fuel from engine in an enclosed area.

- Always fill fuel tank outside in a well ventilated area. Never fill your fuel tank with fuel indoors. (Examples include: basement, garage, barn, shed, house, porch, etc.) Never fill tank near appliances with pilot lights, heaters, or other ignition sources. If the fuel has to be drained, this should be done outdoors. The drained fuel should be stored in a container specifically designed for fuel storage or it should be disposed of carefully.
- Always wipe up excess (spilled) fuel from engine before starting. Clean up spilled fuel immediately. If fuel is spilled, do not start the engine but move product and fuel container from area. Clean up spilled fuel and allow to evaporate and dry after wiping and before starting.
- Allow fuel fumes/vapors to escape from the area before starting engine.
- Test the fuel cap for proper installation before starting and using engine.
- Always run the engine with fuel cap properly installed on the engine.
- Never smoke while refilling engine fuel tank.
- Do not store engine with fuel in fuel tank indoors. Fuel and fuel vapors are highly explosive.
- Handle fuel with care; it is highly flammable.
 - a. Use an approved fuel container.
 - b. Never add fuel to a running engine or hot engine.
 - c. Fill fuel tank outdoors with extreme care. Never fill fuel tank indoors.
 - d. Replace gasoline cap securely and clean up spilled fuel before restarting.

Preparation

- Dress appropriately when operating the earth auger powerhead. Always wear sturdy footwear. Never wear sandals, sneakers or open shoes, and never operate the auger with bare feet. Do not wear loose clothing that might get caught in moving parts.

- Carefully inspect the area to be drilled and remove all foreign objects. Do not drill above underground water lines, gas lines, electric cables, or pipes. Do not operate the earth auger powerhead in soil with large rocks and foreign objects which can damage the equipment.

OPERATION PRECAUTIONS

- This product is intended for use by two operators only. Never attempt to use powerhead with only one operator as serious injury may occur.
- Do not operate earth auger powerhead under the influence of alcohol or drugs.
- Never operate earth auger powerhead without guards, covers, and hoods in place.
- Keep hands, feet, and clothing away from rotating parts. Keep clear of earth auger blade at all times.
- The earth auger blade rotates when powerhead is engaged; the earth auger blade rotates when the throttle control lever is pulled up. Releasing the throttle control lever to neutral stops the earth auger blade.
- Use extreme caution when operating on or crossing gravel drives, walks, or roads. Stay alert for hidden hazards or traffic.
- After striking a foreign object, stop the engine, remove the wire from the spark plug, thoroughly inspect the earth auger and powerhead for any damage, and repair the damage before restarting and operating the earth auger powerhead.
- If vegetation clogs the earth auger blade, stop the engine and disconnect the spark plug wire before removing vegetation by hand.
- If the unit should start to vibrate abnormally, stop the engine and check immediately for the cause. Vibration is generally a warning of trouble.
- Do not run engine indoors; exhaust fumes are deadly.
- Do not overload the machine capacity by attempting to drill too deep at too fast of a rate.
- Never operate the earth auger powerhead without good visibility or light.
- Take all possible precautions when leaving the machine unattended. Disengage throttle control, stop the engine, wait for all moving parts to stop, and make certain guards and shields are in place.
- When leaving the operating position for any reason:
 - shut off the engine.
 - wait for all moving parts to stop.

MAINTENANCE AND STORAGE PRECAUTIONS

- Keep machine, attachments and accessories in safe working condition.
- Check shear bolts, engine mounting bolts and other bolts at frequent intervals for proper tightness to be sure the equipment is in safe working condition.
- To prevent accidental starting, always disconnect and secure the spark plug wire from the spark plug before

- performing powerhead maintenance.
- Never run the engine indoors. Exhaust fumes are deadly.
- Always allow muffler to cool before filling the fuel tank.
- Never store equipment with gasoline in the tank inside a closed building where fumes may reach an open flame or spark. Allow the engine to cool before storing in any building.
- Always refer to the operator's guide instructions for important details if the powerhead is to be stored for an extended period.

BURNS AND FIRES

The muffler, muffler guard and other parts of the engine become extremely hot during the operation of the engine. These parts remain extremely hot after the engine has stopped.

Prevention of Burns and Fires

- Never remove the muffler guard from the engine.
- Never touch the muffler guard because it is extremely hot and will cause severe burns.
- Never touch parts of the engine that become hot after operation.
- Always keep materials and debris away from muffler guard and other hot parts of the engine to avoid fires.

Children and bystanders

Tragic accidents can occur if the operator is not alert to the presence of children and/or bystanders. Never assume that others will remain where you last saw them.

- Keep the area of operation clear of all persons, especially small children and pets. Keep children under the watchful care of a responsible adult.
- Be alert and turn machine off if children enter the area.
- Before and while moving backwards, look behind and down for small children.
- Never allow children to operate the machine.

Auger Safety Rules

- Carry powerhead and auger by handle bars only, NOT by auger.
- Keep all body extremities, loose clothing and foreign objects clear of rotating auger.
- Be sure auger is securely attached to powerhead during use.
- Never carry auger between holes with the engine running.
- This auger is not designed to be utilized as an anchoring device.

Service

- Always stop the engine whenever you leave the equipment, before cleaning, repairing or inspecting the unit. Engine should be turned off and cool. Never make adjustments or repairs with the engine (motor) running. Flip the ON/OFF switch to the **OFF** position to prevent accidental starting.
- Always wear eye protection when you make adjustments or repairs.
- Keep all nuts and bolts tight and keep equipment in good condition.
- Never tamper with safety devices. Check their proper operation regularly.
- When servicing or repairing the machine, do not tip the machine over or up unless specifically instructed to do so in this manual. Service and repair procedures can be done with the machine in an upright position. Some procedures will be easier if the machine is lifted on a raised platform or working surface.
- To reduce fire hazard, keep machine free of grass, leaves or other debris build-up. Clean up oil or fuel spillage. Allow machine to cool before storing.
- Stop and inspect the equipment if you strike an object. Repair, if necessary, before restarting.
- Clean and replace safety and instruction decals as necessary.
- Inspect machine before storage. When not in use, flip the ON/OFF switch to the **OFF** position and store indoors in a dry place locked or otherwise inaccessible to children.
- Use only original equipment parts from *Earthquake*, including all nuts and bolts.

SAFETY DECALS

This powerhead has been designed and manufactured to provide you with the safety and reliability you would expect from an industry leader in outdoor power equipment manufacturing.

Reading this manual and the safety instructions it contains will provide you with the necessary basic knowledge to operate this equipment safely and effectively. We have placed a safety decal on the powerhead to remind you of some of this important information while you are operating the unit.

These important safety decals are shown here to help familiarize you with the location and content of the safety messages you will see as you perform normal drilling operations. Please review these decals now, and if you have any questions regarding its meaning or how to comply with these instructions, reread the complete safety instruction text in this manual.

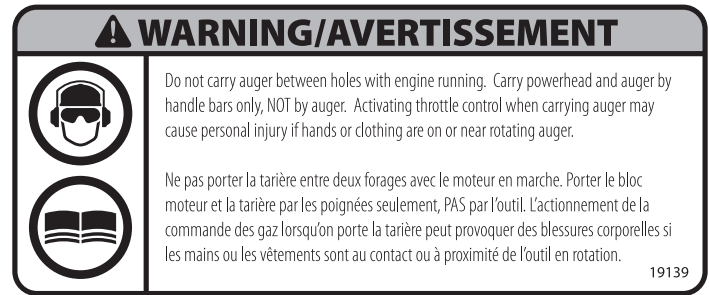

Part No. 19139
Auger Warning Decal



Part No. 19140
This Side Up Warning Decal

Safety or Hazard Symbols



Operational Control Symbols

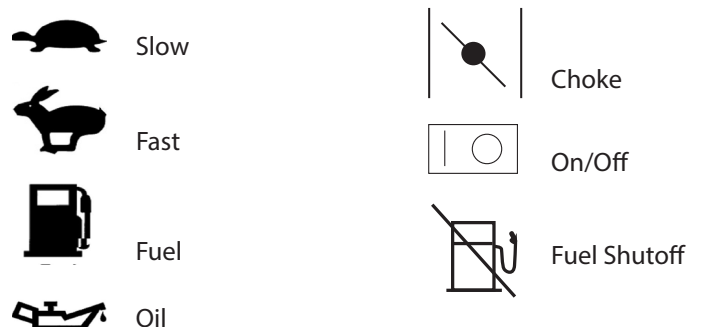

FEATURES

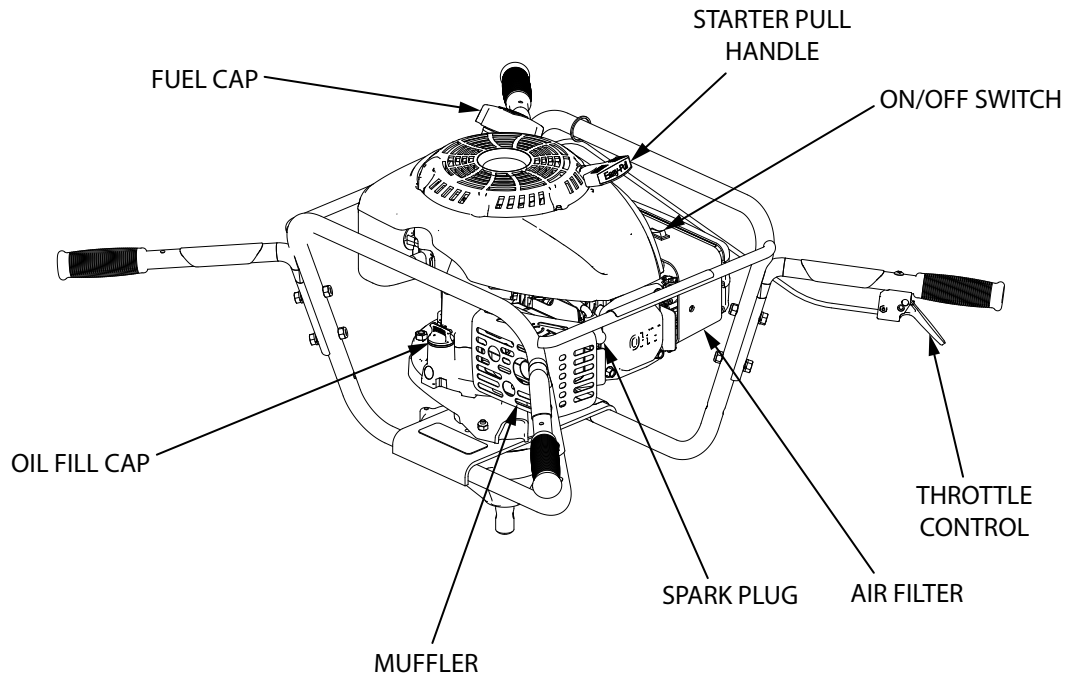

SPECIFICATIONS

ENGINE TYPE/ DISPLACEMENT	4-cycle, 173cc
FUEL TANK CAPACITY	0.25 gallon
OIL TYPE	10W-30
FUEL TYPE	Minimum 87 octane gasoline. NOTE: If using an ethanol blended fuel, a fuel stabilizer, mixed to manufacturer specifications, is recommended.
IGNITION TYPE	Electronic ignition
CHOKE	Auto-choke

PRIMING	Auto-priming
COOLING SYSTEM	Forced air cooling
SPARK PLUG	Refer to Kohler engine manual included with product
GEAR RATIO	30:1
OUTPUT SHAFT TORQUE	232 ft-lb
MAX OUTPUT SHAFT SPEED	125 RPM
START TYPE	Recoil
WEIGHT OF UNIT	55 lb
ASSEMBLED SIZE	34.6 X 31.1 X 19.7 inch

UNPACKING AND ASSEMBLY

Unpack Powerhead

1. Carefully lift the powerhead out of the box and remove any packing material.

Tools Required

- Two (2) 9/16 inch wrenches
- Two (2) 1/2 inch wrenches

Assembly (SEE FIGURE 1)

1. Using two (2) 1/2 inch wrenches, secure handlebar onto frame with two (2) 5/16-18 x 1-1/2 inch bolts, two (2) 5/16 inch washers, and two (2) 5/16 inch nuts.
2. Repeat Step 1 for all four handlebars.
2. Insert the output shaft of the transmission (A) in the open end of the Flex Coil ShockTop (B).
3. Line up the bolt holes through the Flex Coil ShockTop and the output shaft of the transmission.
4. Place the included 3/8-16 x 1.5 inch bolt (C) through the bolt hole.
5. Hand-thread the 3/8-16 lock nut (D) on the bolt.
6. Using two (2) 9/16 inch wrenches, securely tighten the nut and bolt.

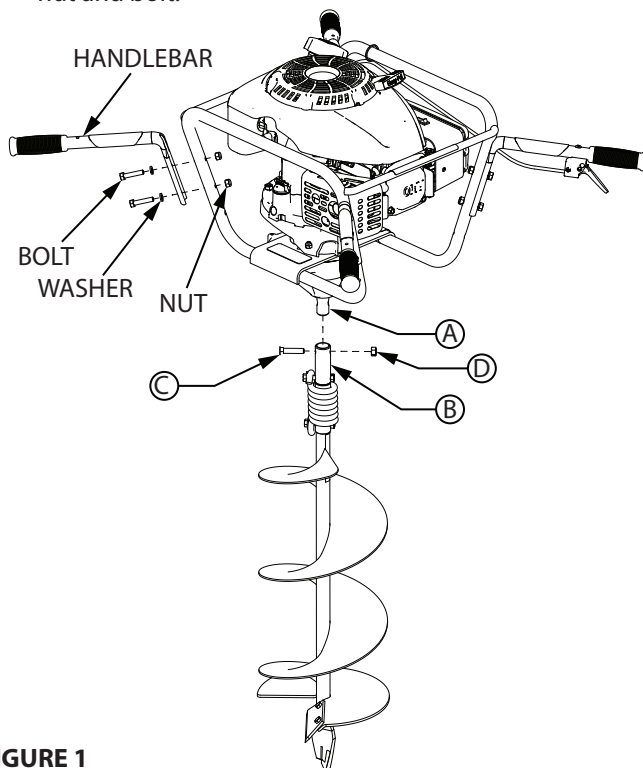

FIGURE 1

NOTICE

NEVER MIX OIL WITH GASOLINE IN A FOUR CYCLE ENGINE.

OPERATION

Pre-Start Checklist

1. Read and understand the operator's manual that came with your unit and the operator's manual that came with the engine.
2. Fill oil sump or check oil level. Check oil level often during engine break-in.
3. Fill fuel tank. Use unleaded, 87+ octane gasoline.
4. Be sure spark plug wire is attached to spark plug

Preparing Engine for Starting

To Check the Oil:

1. Check the engine oil level with the engine stopped and in a level position.
2. Remove the oil filler cap/dipstick and wipe it clean.
3. Insert the oil filler cap/dipstick in the oil filler neck and retighten.
4. Remove the dipstick to check the oil level.
5. If the oil level is near or below the lower limit mark on the dipstick, fill with the recommended oil to the upper limit mark. **DO NOT** overfill.

Fuel Recommendations:

- Use clean, fresh, regular 87+ octane unleaded gasoline.
- This engine is certified to operate on unleaded gasoline. Unleaded gasoline products produce fewer engine and spark plugs deposits and extends exhaust system life.
- Never use stale or contaminated gasoline or an oil/gasoline mixture. Avoid getting dirt or water in the fuel tank.
- Occasionally, you may hear a light "spark knock" or "pinging" (metallic rapping noise) while operating under heavy loads. This is no cause for concern.
- If spark knock or pinging occurs at a steady engine speed, under a normal load, change gasoline brands. If spark knock or pinging persists, contact Earthquake customer service.
- Gasoline with up to 10% Ethanol (Gasohol) is acceptable, but not recommended without fuel stabilizer added.
- **DO NOT** use unapproved gasoline such as E15 and E85.

! WARNING

DO NOT REFUEL WHILE SMOKING, NEAR OPEN FLAME, OR OTHER POTENTIAL HAZARDS.

FUEL IS HIGHLY FLAMMABLE AND MUST BE HANDLED WITH CARE. NEVER FILL THE FUEL TANK WHEN THE ENGINE IS HOT OR RUNNING. ALWAYS MOVE OUTDOORS TO FILL THE FUEL TANK.

Filling Fuel Tank

1. Shut-off engine and allow engine to completely cool before refilling the fuel tank.
2. Move to a well ventilated area, outdoors, away from flames and sparks.
3. Clean debris from area around the fuel cap.
4. Loosen fuel cap slowly. Place the cap on a clean, dry surface.
5. Carefully add fuel without spilling.
6. Do not fill fuel tank completely full, allow space for fuel to expand.
7. Immediately replace fuel cap and tighten. Wipe off spilled fuel and allow to dry before starting engine.

IMPORTANT

READ ENGINE MANUAL AND FOLLOW INSTRUCTIONS FOR FUEL TYPE, STARTING, ETC.

THE CLUTCH WILL TRANSFER MAXIMUM POWER AFTER ABOUT TWO HOURS OF NORMAL OPERATION. DURING THIS BREAK-IN PERIOD CLUTCH SLIPPAGE MAY OCCUR. THE CLUTCH SHOULD BE KEPT FREE OF OIL OR OTHER MOISTURE FOR EFFICIENT OPERATION.

THE EARTH AUGER UNIT SHOULD BE OPERATED FOR NO MORE THAN 20 DEGREES IN ANY DIRECTION DURING CONTINUOUS USE, AND LIMITED TO 30 DEGREES INTERMITTENTLY. THIS IS RECOMMENDED FOR ADEQUATE LUBRICATION AND FUEL DELIVERY.

WHEN DIGGING IN HEAVY SOIL, LIFT THE EARTH AUGER UNIT OUT OF THE HOLE EVERY ONE FOOT OF DEPTH.

DO NOT USE EARTH AUGER IN ICE.

DRILL HOLES WITHOUT PLACING EXCESSIVE BODY WEIGHT ON THE UNIT. THE AUGER OPERATES MOST EFFICIENTLY WITH A SHAVING ACTION CAUSED BY THE WEIGHT OF THE UNIT ITSELF.

IF ENGINE FAILS TO START AFTER PERFORMING THE STARTING PROCEDURES, CONTACT OUR CUSTOMER SERVICE DEPARTMENT AT 800-345-6007.

To Start Engine

1. Check the engine oil level.
2. Make sure engine drive controls, if equipped, are disengaged.
3. Flip the on/off switch to **ON** position.
4. Grasp starter handle and pull rope out, slowly, until it pulls slightly harder. Then pull rope with a rapid full arm stroke. Let rope return to start slowly.

NOTE: This engine is equipped with an auto-choke and is auto-priming.

To Stop Engine

1. Flip the on/off switch to the **OFF** position.

WARNING

DO NOT STORE ENGINE INDOORS WITH FUEL IN THE TANK. FUEL AND FUEL VAPORS ARE HIGHLY FLAMMABLE.

NEVER MIX FUEL AND OIL DIRECTLY IN ENGINE FUEL TANK. USE ONLY NONMETAL, PORTABLE FUEL CONTAINERS APPROVED BY THE UNDERWRITER'S LABORATORY (U.L.) OR THE AMERICAN SOCIETY FOR TESTING & MATERIALS (ASTM).

AN ADULT MUST ALWAYS HANDLE AND FILL THE ENGINE WITH FUEL.

ALWAYS HANDLE GAS IN A WELL VENTILATED AREA, OUTDOORS, AWAY FROM FLAMES OR SPARKS.

DO NOT START ENGINE IF FUEL IS SPILLED. WIPE OFF EXCESS FUEL AND ALLOW TO DRY. REMOVE ENGINE FROM AREA TO AVOID SPARKS.

NEVER RUN ENGINE INDOORS. EXHAUST FUMES ARE DEADLY.

FAILURE TO FOLLOW THESE WARNINGS CAN CAUSE DAMAGE TO EQUIPMENT AND INJURY TO PERSONNEL.

CAUTION

MAKE SURE THE UNIT IS IN A STABLE POSITION BEFORE PULLING THE STARTER HANDLE. WHEN THE UNIT STARTS TO FIRE OR RUN, RELEASE THE THROTTLE CONTROL MOMENTARILY WITH ONE HAND AND RETURN YOUR OTHER HAND TO THE HANDLEBAR POSITION TO MAINTAIN CONTROL AND STABILITY OF THE UNIT WITH BOTH HANDS.

MAINTENANCE AND STORAGE

Steps For Working On Equipment

1. Turn engine switch to the **OFF** position.
2. Disconnect the spark plug wire from the spark plug.
3. Securely place the disconnected spark plug wire away from the spark plug and any metal parts. This must always be done or arcing may occur between spark plug wire and metal parts.
4. Replace or repair the part on the powerhead
5. Check all parts that were repaired, or removed during repair, that they are secure and fit correctly.

NOTE: All repair parts must come from the factory. Never replace parts that are not specifically designed for the powerhead.

6. Reconnect the spark plug wire.

Powerhead Maintenance

1. Keep all screws, nuts, and bolts tight.
2. For cold weather operation, store the unit in a cool environment. Transferring the unit from a cold to a warm place can cause the build up of harmful condensation.
3. If auger performance decreases, carefully inspect cutter edge of blade for any signs of wear. If the blades show any of these signs, they need to be replaced.
4. Always allow muffler to cool before filling fuel tank.
5. When storing for over one month, use fuel stabilizer.
6. Do not fill fuel tank indoors or when engine is running or is hot.

Engine Maintenance

Please read your engine manual, included with the unit, and observe its recommendations to extend the life of your engine. Your engine manual provides detailed information about your engine and a maintenance schedule.

Transporting Your Earth Auger Powerhead

1. Never transport powerhead inside an enclosed space or vehicle. Fuel or fuel vapors may ignite causing serious injury or death.
2. If fuel is present in the fuel tank, transport in an open vehicle in an upright position.
3. If an enclosed vehicle must be used, remove fuel in an approved red fuel container. **DO NOT** siphon by mouth.
4. Run engine to use up the fuel in the carburetor and fuel tank. Always run engine in a well ventilated area.
5. Wipe away any spilled fuel from powerhead and earth auger. Allow to dry prior to transport.
6. When transporting your powerhead, make sure you position the unit according to the "This Side Up When Not In Use decal" **SEE FIGURE 2**

***Scan this QR code with your smartphone for helpful hints and tips for using your auger. www.getearthquake.com**



You may need to get a QR Code® reader from your smartphone app store. Data rates may apply.

! WARNING

DO NOT ATTEMPT TO START ENGINE IN THE FOLLOWING WAYS:

- **DO NOT USE STARTING FLUID**
- **DO NOT SPRAY FLAMMABLE LIQUIDS OR VAPORS INTO AIR CLEANER, CARBURETOR, OR SPARK PLUG CHAMBER.**
- **DO NOT REMOVE SPARK PLUG AND ATTEMPT TO START ENGINE. FLAMMABLE FUEL CAN SPRAY OUT AND IGNITE FROM A SPARK FROM SPARK PLUG.**

! WARNING

ALWAYS WEAR A PROTECTIVE HEARING DEVICE. IF AUGER IS MOUNTED TO ENGINE, ALL SAFETY GUARDS MUST BE SECURELY ON TO AVOID SERIOUS INJURY.

STARTER ROPE CAN CAUSE AN UNANTICIPATED JERK TOWARDS ENGINE. PLEASE FOLLOW INSTRUCTIONS TO AVOID INJURY.

NEVER LEAVE ENGINE RUNNING WHILE UNATTENDED. TURN OFF AFTER EVERY USE.

NEVER CARRY AUGER FROM ONE LOCATION TO ANOTHER WHILE ENGINE IS RUNNING.

DO NOT START ENGINE IF FUEL IS SPILLED. WIPE OFF EXCESS FUEL AND ALLOW TO DRY. REMOVE ENGINE FROM AREA TO AVOID SPARKS.

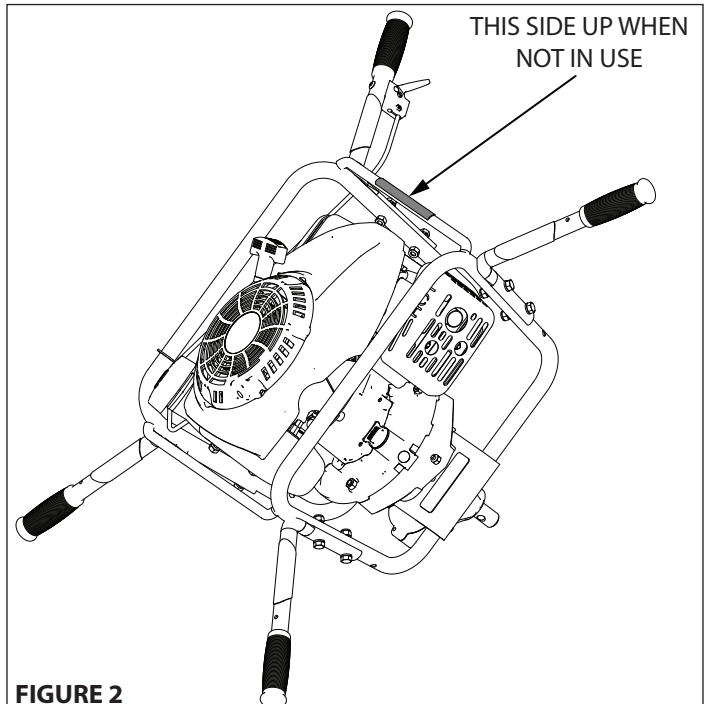

FIGURE 2

 **WARNING**

PRACTICE SAFETY AT ALL TIMES. ENGINE MUST BE TURNED OFF AND ALLOWED TO COOL, AND SPARK PLUG WIRE MUST BE DISCONNECTED BEFORE ATTEMPTING ANY MAINTENANCE OR REPAIR.

TO PREVENT ACCIDENTAL STARTING:

ENGINE MUST BE TURNED OFF AND COOL, AND SPARK PLUG WIRE MUST BE REMOVED FROM SPARK PLUG BEFORE CHECKING AND ADJUSTING ENGINE OR EQUIPMENT.

TEMPERATURE OF MUFFLER AND NEARBY AREAS MAY EXCEED 150° F (65° C). AVOID THESE AREAS.

CHECK AUGER OFTEN FOR LOOSE NUTS AND BOLTS. KEEP THESE ITEMS TIGHTENED.

NEVER STORE ENGINE WITH FUEL IN THE TANK INSIDE A BUILDING. POTENTIAL SPARKS MAY BE PRESENT FOR IGNITION OF FUEL AND FUEL VAPORS.

AN ADULT MUST ALWAYS DO MAINTENANCE AND REPAIR ON ENGINE AND AUGER.

ENGINE MUST BE SHUT-OFF, COOL, AND SPARK PLUG WIRE REMOVED BEFORE ANY REPAIR OR MAINTENANCE CAN BE DONE.

 **DANGER**

DO NOT SIPHON FUEL BY MOUTH. GASOLINE IS TOXIC AND CAN CAUSE SERIOUS PERSONAL INJURY.

NEVER STORE POWERHEAD WITH FUEL IN THE FUEL TANK INSIDE AN ENCLOSED AREA OR BUILDING. FUEL VAPORS CAN COLLECT AND CAUSE A FIRE.

TROUBLESHOOTING AND REPAIR

At *Earthquake*, we build quality and durability into the design of our products; but no amount of careful design by us, and careful maintenance by you, can guarantee a repair-free life for your Earthquake powerhead. Most repairs will be minor, and easily fixed by following the suggestions in the troubleshooting guide in this section.

The guide will help you pinpoint the causes of common problems and identify remedies.

For more complicated repairs, you may want to rely on an authorized service center or Earthquake. Earthquake will make the necessary repairs if a service center is not available. A parts breakdown is located toward the end of this manual.

We will always be glad to answer any questions you have, or help you find suitable assistance.

Ordering Replacement Parts

Parts can be obtained from an authorized service dealer or direct from the factory. To order parts visit; www.getearthquake.com or call 1-800-345-6007.

For other general questions, you can e-mail us at: info@getearthquake.com.

Please include the following information with your order:

- 1) Part numbers
- 2) Part description
- 3) Quantity
- 4) Model number and serial number

Spare Parts

Only use approved *Earthquake* service parts.

Long-Term Storage

If your powerhead will not be used for more than one month, prepare it for long term storage.

Steps for Long-Term Storage

1. Mix an appropriate amount of fuel stabilizer to fresh gasoline in the ratio recommended on the stabilizer packaging. Run the engine for five minutes to distribute the stabilizer mixture throughout the fuel system. This will prevent gum, varnish and corrosion build up in your fuel system during long-term storage for up to 12 months.
2. Change oil according to engine manual.
3. Remove spark plug, pour one (1) fl-oz of clean engine oil into spark plug hole. Cover hole with a rag. Pull starter handle slowly several times to distribute oil. Install spark plug. **DO NOT CONNECT SPARK PLUG WIRE.**
4. Remove auger from powerhead and apply a thin layer of grease to the output shaft of the transmission.
5. Clean entire powerhead and earth auger(s).
6. Store powerhead in storage position in a clean, dry building that is inaccessible to children. **SEE FIGURE 2**

TROUBLESHOOTING GUIDE

PROBLEM	POSSIBLE CAUSE	REMEDY/ACTION
Engine will not start	1. Ignition switch off	1. Flip switch to ON position
	2. Spark plug wire disconnected	2. Connect spark plug wire to spark plug
	3. Out of fuel	3. Refuel
	4. Spark plug wet, faulty or improperly gapped	4. Clean, replace or gap spark plug
	5. Stale fuel	5. Drain old fuel and replace with fresh. Use fuel stabilizer at end of season or during long term storage
Engine runs rough, floods during operation	1. Dirty air filter	1. Clean or replace air filter
	2. Carburetor out of adjustment	2. Contact Kohler via www.KohlerEngines.com or call 1-800-544-2444
Engine is hard to start	1. Stale fuel	1. Drain old fuel and replace with fresh fuel. Use fuel stabilizer at end of season or during long term storage
	2. Spark plug wire loose	2. Make sure spark wire is securely attached to spark plug
	3. Dirty carburetor	3. Clean carburetor, use fuel stabilizer, new gas can
Engine misses or lacks power	1. Clogged fuel filter	1. Clean fuel tank, replace fuel filter
	2. Clogged air filter	2. Clean or replace air filter
	3. Carburetor out of adjustment or bad	3. Contact Kohler via www.KohlerEngines.com or call 1-800-544-2444
	4. Spark plug wet, faulty or improperly gapped	4. Clean, replace or gap spark plug
Engine runs, then quits	1. Clogged fuel filter	1. Clean fuel tank, replace fuel filter
	2. Carburetor out of adjustment or bad	2. Contact Kohler via www.KohlerEngines.com or call 1-800-544-2444
Engine revs too high	1. Carburetor out of adjustment or bad	1. Contact Kohler via www.KohlerEngines.com or call 1-800-544-2444
Auger turn at idle	1. Idle speed too high	1. Adjust idle speed lower
	2. Broken clutch spring	2. Replace clutch
Auger turns, but has no power	1. Carburetor out of adjustment or bad	1. Contact Kohler via www.KohlerEngines.com or call 1-800-544-2444
	2. Broken transmission	2. Call customer service
	3. Worn clutch shoes	3. Replace clutch
Auger jumps	1. Blade damaged	1. Replace with new blade
Auger cuts slowly	1. Dull blade	1. Replace with new blade
	2. Damaged fishtail point	2. Replace fishtail point
	3. Blade installed upside down	3. Install blade right side up (bevel side down)

Contact customer service if above remedies fail.

ILLUSTRATED PARTS BREAKDOWN - Powerhead Assembly

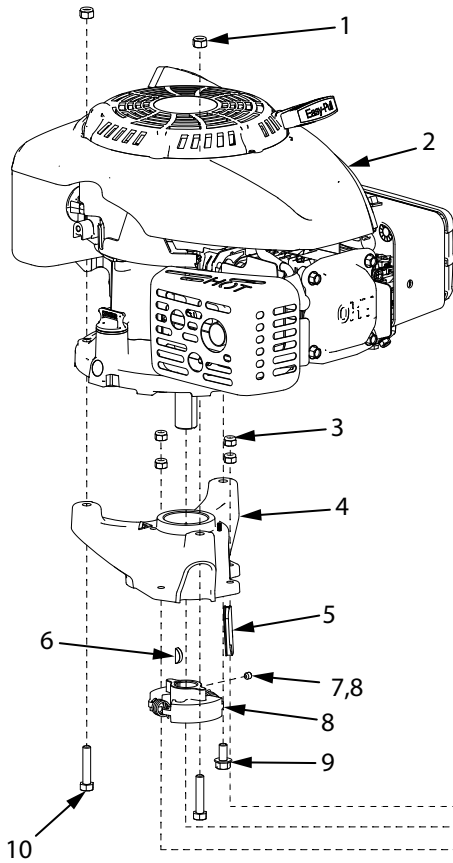

KEY #	PART NO.	DESCRIPTION	QTY.
1	60G5NY	NUT 5/16-18 NYLOCK	10
2*	---	KOHLER XT775 VERTICAL ENGINE	1
3	67538	NUT 1/4-20 IN NYLOCK	4
4	22632	ADAPTER 9800 SERIES	1
5	22664	COVER ADAPTER CLUTCH ACCESS	1
6	WK6	KEY WOODRUFF 5/32 X 5/8 IN	1
7	715	SET SCREW 1/4-20 X 1/4 IN CUP POINT	1
8	9825	ASSEMBLY CLUTCH ROTOR	1
9	18106	BOLT M8 X 1.25 X 20 MM HEX FLANGE	1
10	503	BOLT 5/16-18 X 1-1/2 HEX HEAD	10
11	28046	KIT HANDLEBAR FRAME 9800 SERIES	1
12	9827	HANDLE W/GRIP AND THROTTLE HOLE	4
13	4814	BOLT 10-24 X 1-1/4 PHILLIPS HEAD	1
14	9211	HANDLE GRIP 7/8 IN ID	4
15	504	WASHER 5/16 IN SPRING LOCK	8
16	22907	THROTTLE CABLE	1
17	4819	ASSEMBLY TRIGGER LONG THROW	1
18	22920	KIT THROTTLE CABLE AND TRIGGER	1
19	98005	TRANSMISSION ASSEMBLY	1
20	8935	BOLT 1/4-20 X 2-1/2 IN SOCKET HEAD	4

* For service parts contact Kohler via www.KohlerEngines.com or call 1-800-544-2444

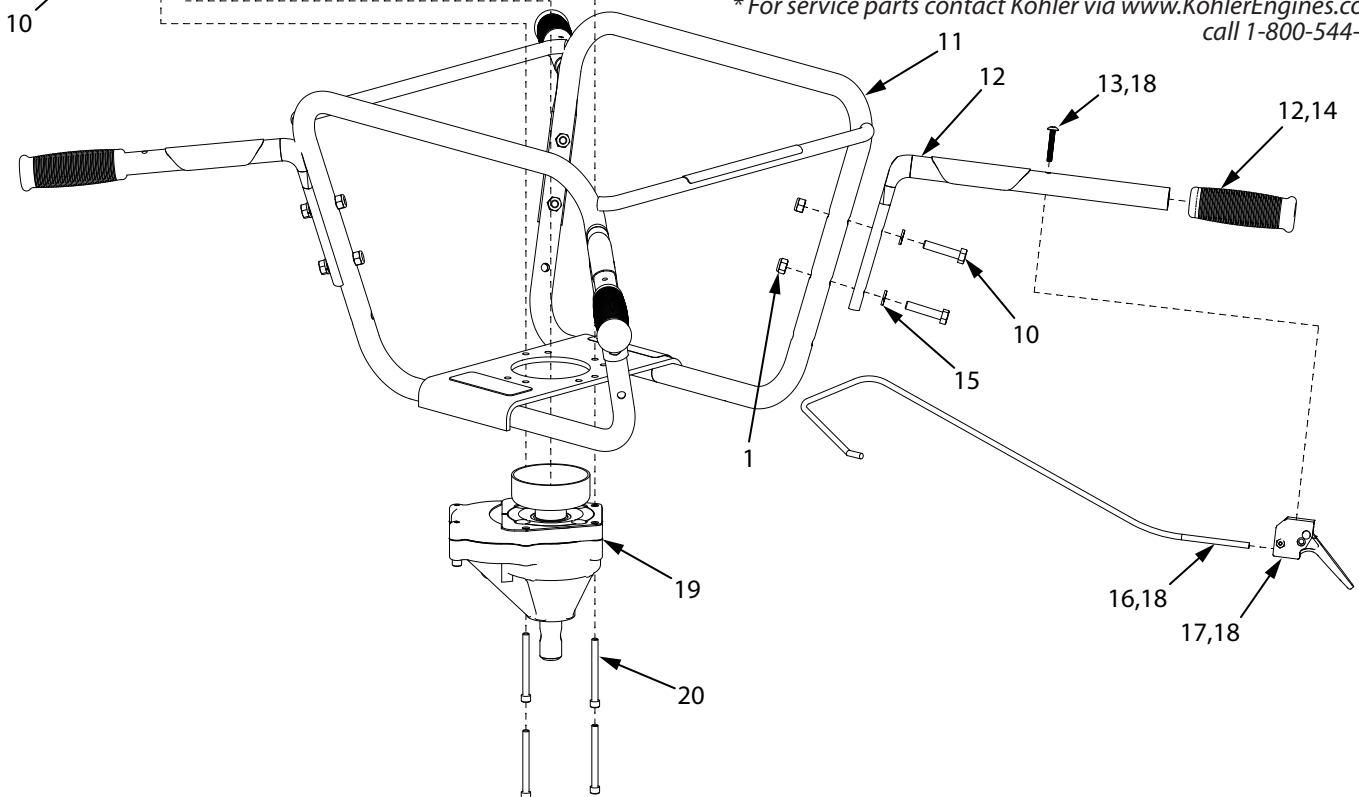

ILLUSTRATED PARTS BREAKDOWN - Transmission Assembly

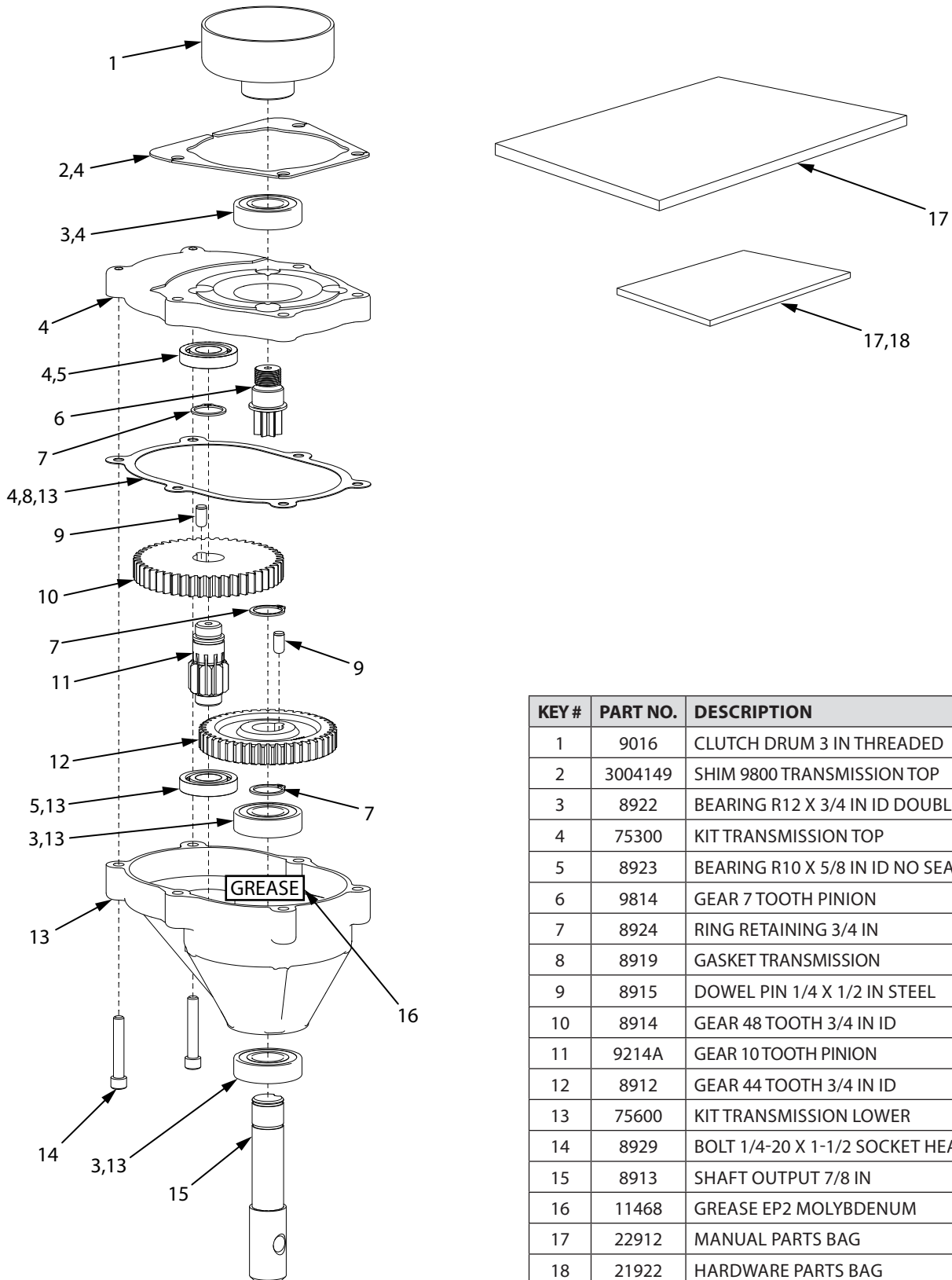

KEY #	PART NO.	DESCRIPTION	QTY.
1	9016	CLUTCH DRUM 3 IN THREADED	1
2	3004149	SHIM 9800 TRANSMISSION TOP	1
3	8922	BEARING R12 X 3/4 IN ID DOUBLE SEAL	3
4	75300	KIT TRANSMISSION TOP	1
5	8923	BEARING R10 X 5/8 IN ID NO SEAL	2
6	9814	GEAR 7 TOOTH PINION	1
7	8924	RING RETAINING 3/4 IN	3
8	8919	GASKET TRANSMISSION	1
9	8915	DOWEL PIN 1/4 X 1/2 IN STEEL	2
10	8914	GEAR 48 TOOTH 3/4 IN ID	1
11	9214A	GEAR 10 TOOTH PINION	1
12	8912	GEAR 44 TOOTH 3/4 IN ID	1
13	75600	KIT TRANSMISSION LOWER	1
14	8929	BOLT 1/4-20 X 1-1/2 SOCKET HEAD	2
15	8913	SHAFT OUTPUT 7/8 IN	1
16	11468	GREASE EP2 MOLYBDENUM	1
17	22912	MANUAL PARTS BAG	1
18	21922	HARDWARE PARTS BAG	1

ILLUSTRATED PARTS BREAKDOWN - Auger Parts List

EA2F, EA3F

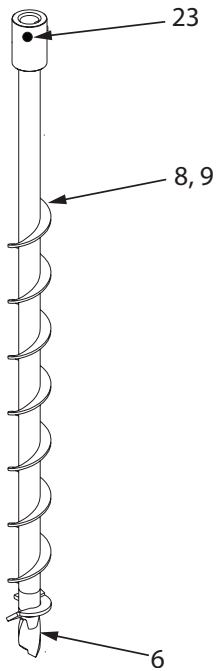

EA4F

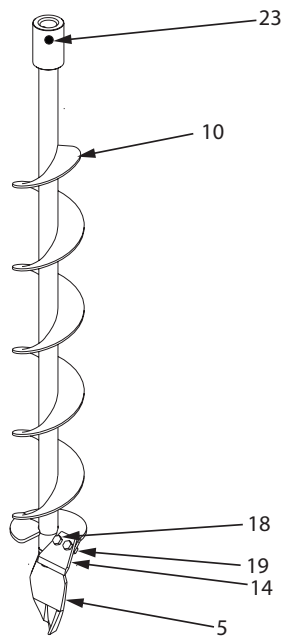

EA6F

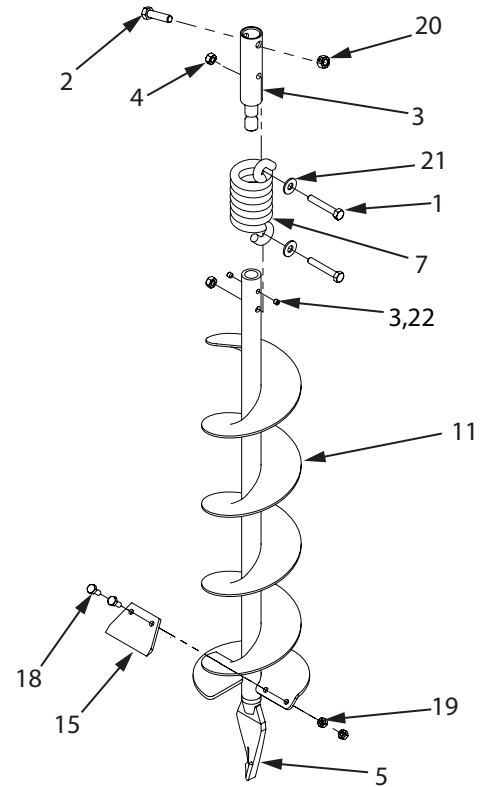

EA8F

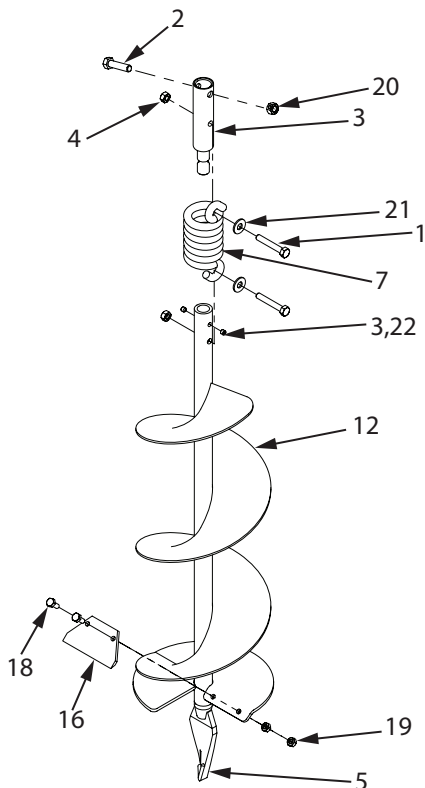

EA10F

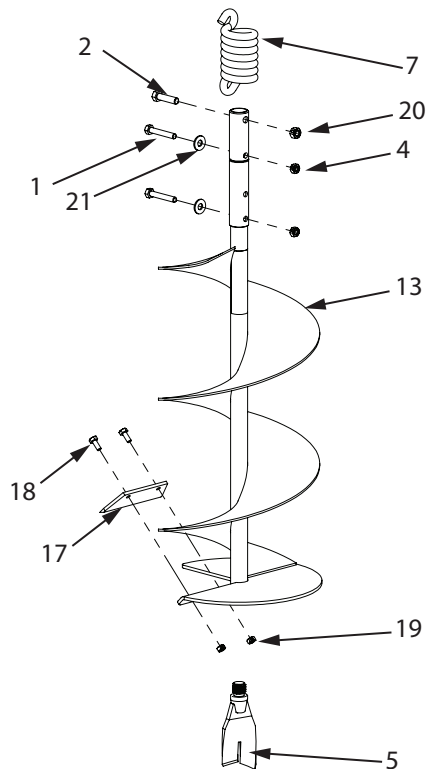

EXT12

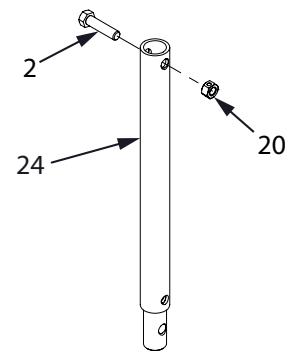

EXT18

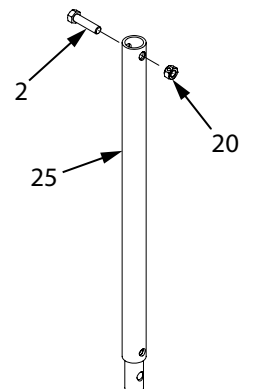

ILLUSTRATED PARTS BREAKDOWN - Auger Parts List

KEY NO.	PART NO.	DESCRIPTION	QTY.
1	1423	BOLT-HHCS, 5/16-18 X 2", GR5	2
2	1433	BOLT-HHCS, 3/8-16 X 1-1/2" GR5	2
3	22142	SHOCK TOP 1-PC	1
4	60G56	NUT-HEX 2-WAY REVERSIBLE LOCK-NUT, 5/16-18	2
5	8958HD	FISHTAIL POINT	1
6	8970	EARTH POINT	1
7	8980	SHOCK SPRING	1
8	EA2F	EARTH AUGER, 2" W/FISHTAIL POINT	1
9	EA3F	EARTH AUGER, 3" W/FISHTAIL POINT	1
10	EA4F	EARTH AUGER, 4" W/FISHTAIL POINT	1
11	EA6F	EARTH AUGER, 6" W/FISHTAIL POINT	1
12	EA8F	EARTH AUGER, 8" W/FISHTAIL POINT	1
13	EA10F	EARTH AUGER, 10" W/FISHTAIL POINT	1
14	EB4*	EARTH BLADE, 4"	1
15	EB6*	EARTH BLADE, 6"	1
16	EB8*	EARTH BLADE, 8"	1
17	EB10*	EARTH BLADE, 10"	1
18	EBOLT	BOLT-HEX, 1/4-28 X 5/8", GRADE 5	2
19	ENUT	NUT-NYLOC, 1/4-28	2
20	2104	NUT HEX LOCKING, 3/8-16	2
21	WF516	WASHER-FLAT, 5/16"	2
22	715	SET SCREW 1/4-20 X 1/4 SCPC BLK OXIDED	2
23	8955	BOLT 3/8-16 X 1-1/4 SHCS	1
24	EXT12	DEPTH EXTENSION, 12"	1
25	EXT18	DEPTH EXTENSION, 18"	1
ITEMS NOT SHOWN			
-	EB6HD*	HEAVY DUTY EARTH BLADE, 6"	1
-	EB8HD*	HEAVY DUTY EARTH BLADE, 8"	1
-	EB10HD*	HEAVY DUTY EARTH BLADE, 10"	1

*Includes mounting hardware EBOLT (2) and ENUT (2)



WARRANTY TERMS AND CONDITIONS

Ardisam, Inc. (Ardisam) warrants this powerhead under a five-year limited warranty to be free from defects in the material or workmanship or both for a period not exceeding sixty consecutive months from the date of original purchase by the first retail consumer or first commercial end user. This warranty does not apply to the engine mounted on the product. Refer to engine manual for engine warranty details. "Consumer use," means personal recreational use by a retail consumer. "Commercial use," or "commercial application" means all other uses, including use for commercial, income producing or rental purposes. Once a product has experienced commercial use, it shall thereafter be considered as a commercial use product for the purpose of this warranty. This warranty applies to the original owner that provides a proof of purchase. This warranty is not transferable. The warranty period begins on the date of purchase by the first retail consumer or commercial end user, and continues for the sixty month consecutive period thereafter. Any unit used in a commercial application is covered for a period of 90 days after purchase by the first commercial end user. For the warranty to be valid, the product must be registered online within 30 days of purchase, or the warranty card must be filled out and received by Ardisam within 30 days of purchase. Ardisam shall not be obligated for transportation charges that result from repair or replacement under the terms of this warranty. Transportation charges are the sole responsibility of the purchaser.

This warranty excludes augers and blades due to normal wear, wear items such as grips and cables, routine maintenance items such as filter elements, o-rings, seals, lubricants, and tune-ups, rotating parts, accessory parts such as augers, extensions, and shocktops. Negligent use such as using the powerhead and auger for a purpose other than for which it was designed and manufactured, continued use of powerhead and auger after sudden change in vibration, using the powerhead and auger in violation of local codes, ordinances and good trade practices voids this warranty. *These warranties apply only to products which have not been subjected to negligent use, abuse, misuse, overload, improper installation, alteration, accident, acts of God (or other events beyond Ardisam's control) lightning, vandalism, unauthorized parts, or if repairs have been performed at a non-authorized service facility. These warranties shall not cover damage from normal wear and tear, normal maintenance parts and services, or improper installation, operation, storage, or maintenance; nor operating the equipment above recommended maximums as stated in this manual and the accompanying engine manual.

This limited warranty applies to defects in the material or workmanship of the product only. There is no other express warranty. Implied warranties, including those of merchantability and fitness for a particular purpose, are limited to one year from purchase, or to the extent permitted by law. All other implied warranties are excluded. Liability for incidental or consequential damages are excluded to the extent exclusion is permitted by law. Ardisam does not assume, and does not authorize any other person to assume for Ardisam, any liability in connection with the sale of Ardisam products. **To be at "No Charge," warranty work must be sent directly to and performed by Ardisam or an Ardisam Authorized Warranty Service Facility.** To obtain warranty service and/or replacement instructions, contact the Ardisam Customer Service Department at 800-345-6007. If you choose to ship your product to Ardisam for warranty repair, you must first have prior approval from Ardisam by calling the Ardisam Customer Service Department for a return material authorization number (RMA#). Under these circumstances, all items must be shipped prepaid. Ardisam will, in its discretion, at no charge, repair or replace any defective part to which this warranty applies. Ardisam retains the right to change models, specifications and price without notice. Ardisam shall not be obligated to ship any repair or replacement product to any location outside of the United States of America or Canada. Some states and countries do not allow the limitations on how long an implied warranty lasts, or the exclusion or limitation of incidental or consequential damages, so the above limitation may not apply to you. This warranty gives you specific legal rights, and you may also have other rights which vary from state to state and country to country.



Earthquake®, Division of Ardisam, Inc.
1160 8th Avenue, PO Box 666
Cumberland, WI 54829
800-345-6007 | Fax 715-822-2223
E-mail: info@getearthquake.com

All weights, specifications and features are approximate and are subject to change without notice. Due to continuous product improvements, product images may not be exact. Items used for props not included. Some assembly may be required.

Check for parts online at www.getearthquake.com or call 800-345-6007 M-F 8-5

Free Manuals Download Website

<http://myh66.com>

<http://usermanuals.us>

<http://www.somanuals.com>

<http://www.4manuals.cc>

<http://www.manual-lib.com>

<http://www.404manual.com>

<http://www.luxmanual.com>

<http://aubethermostatmanual.com>

Golf course search by state

<http://golfingnear.com>

Email search by domain

<http://emailbydomain.com>

Auto manuals search

<http://auto.somanuals.com>

TV manuals search

<http://tv.somanuals.com>