

# **GoWISEUSA<sup>®</sup>**

## Instruction Manual

AIRWISE FRYER

GW22638/GW22639/GW22640/GW22651



[WWW.GOWISEPRODUCTS.COM](http://WWW.GOWISEPRODUCTS.COM)

# Table of Contents

Product Introduction .....	3
Important Safeguards .....	4
Electromagnetic Fields .....	6
Product Structure & Features .....	7
Before First Use .....	8
How to use your Air Fryer .....	9
Cooking Guide .....	11
Cleaning your Air Fryer .....	13
Troubleshooting .....	14
Warranty .....	15

## Product Introduction

GoWISE USA would like to introduce the GW22638(black), GW22639(red), GW22640(white), and GW22651(plum) model of Air Fryers. The air fryers use Rapid Air Technology to prepare food that would usually need to be submerged in oil to be fried. Rapid Air Technology works by quickly circulating hot air around a grill top. The best parts about the air fryer is that it heats food in all directions and most dishes require little to no oil at all. This is a 3.7 Quart Air Fryer with 8 built-in smart programs such as Warm, Fries, Chicken, Steak, Shrimp, Pork (and other meats), Cake, and Fish. They also have a wide temperature range from 170°F - 400°F, and a Cook timer up to 30 minutes. This Air Fryer is an easy and healthy way to prepare your favorite fried foods.

## Important Safeguards

1. READ THE MANUAL.
2. Keep the box and packing material for storage.
3. Do not immerse the cord, plug, or any part of the appliance in water or any other liquids to avoid electric shock.
4. Keep all the ingredients in the basket to prevent any contact from heating elements.
5. Do not cover the air inlet and air outlet when the appliance is on.
6. Do not fill the pan with oil. Filling the pan with oil is a fire hazard.
7. Do not touch the inside of the appliance while it is operating.
8. Do not use the appliance if there is any damage to the plug, main cord, or other parts.
9. Do not go to any unauthorized person to replace or fix the appliance. This may void your warranty.
10. Keep the main cord away from hot surfaces.
11. Do not plug in the appliance or use the appliance with wet hands.
12. Make sure that the appliance is plugged into the wall socket properly.
13. Make sure that the appliance is out of reach of children, especially when the fryer is operating.
14. Do not connect the appliance to an external timer switch.
15. Do not place the appliance on or near combustible materials, such as a tablecloth or curtain.
16. Do not place the appliance against a wall or any other appliances. Leave at least 5 inches of free space on the back, sides, and above the appliance.
17. Do not place anything on top of the appliance.
18. Do not use the appliance for any other purposes other than described in this manual.
19. Do not leave the appliance unattended while it is operating.
20. During hot air frying, hot steam is released through the air outlet openings. Keep your hands and face at a safe distance from the steam and from the air outlet opening. Be cautious of hot steam and air when you remove the pan from the appliance. Any accessible surface may become hot during use.

(continued on next page)

## Important Safeguards(continued)

21. DO NOT PUT UNIT ON STOVE. THE WARRANTY WILL BE VOIDED.
22. Immediately unplug the appliance if you see dark smoke coming out of it. Wait for the smoke emission to stop before you remove the pan from the appliance.
23. Ensure that the appliance is placed on a horizontal, even, and stable surface.
24. This appliance is designed for household use only. It is not safe to use in environments such as staff kitchens, farms, motels, and other non-residential environments.
25. Always wait 30 minutes for the appliance to cool down before handling or cleaning it.
26. The warranty is void if the appliance is used for professional or semi-professional purposes, or it is not being used according to instructions.

## Electromagnetic Fields(EMF)

This GoWISE USA air fryer complies with all standards regarding Electro-magnetic fields(EMF). Under proper handling, there is no harm done to the human body based on available scientific evidence.

If you have any questions regarding your Air Fryer, please contact Customer Service at 1-855-233-9199.

# Product Structure & Features

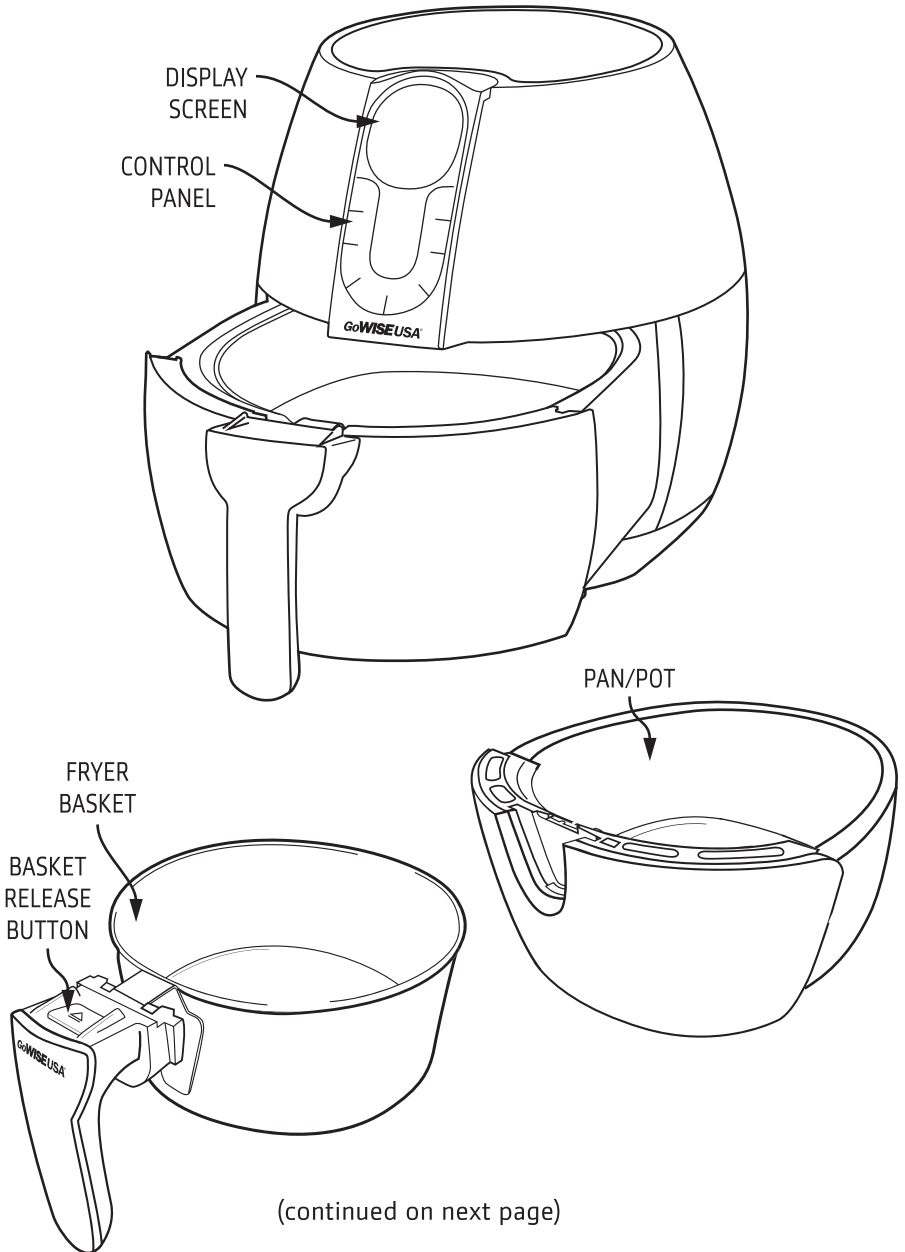

(continued on next page)

## Product Structure & Features(continued)

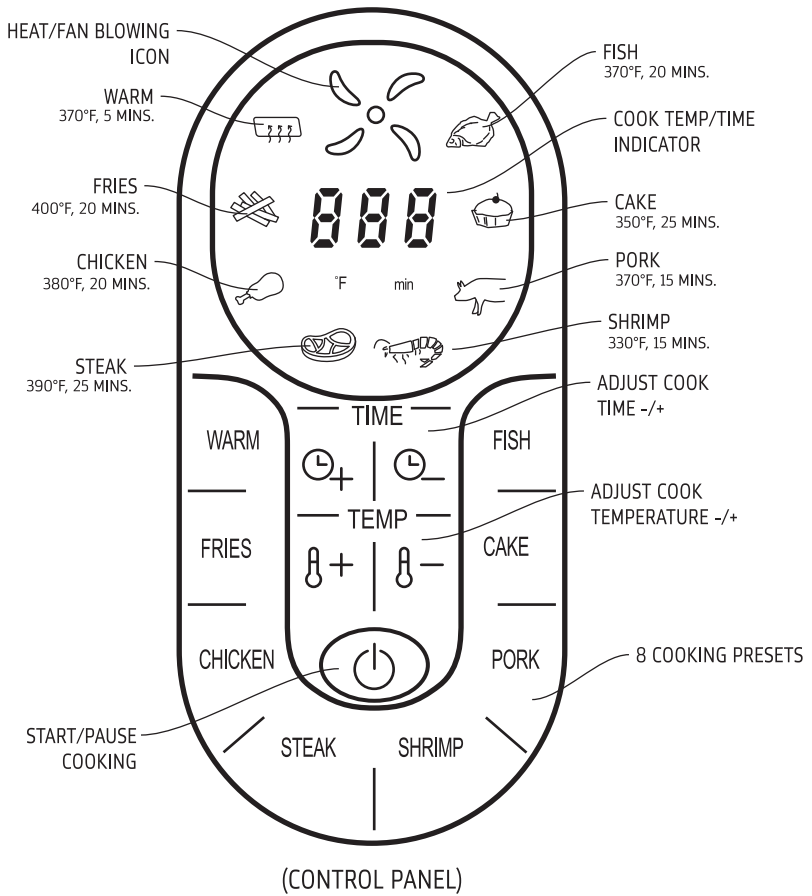

## Before First Use

1. Remove all packaging materials, stickers, and labels.
2. Clean the basket and pan with hot water, soap, and a non-abrasive sponge.
3. Wipe the inside and outside of the appliance with a clean cloth

NOTE: There is no need to fill pan with oil and frying fat because the appliance works with hot air.



## How to use your Air Fryer

1. Place the air fryer on a flat and even surface. DO NOT PLACE THE FRYER ON A SURFACE THAT IS NOT HEAT RESISTANT. That will void your warranty.
2. Place the basket into the pan. DO NOT FILL THE PAN WITH OIL OR ANY OTHER LIQUID.
3. Place the ingredients in the basket and then push the basket and pan back into the appliance.
4. Press the start button.
5. Set your cooking time and temperature by either choosing one of the 8 presets or manually setting it with the "+" or "-" icons.
6. Once you have set your cooking time and temperature, press the START button again.
7. The heat and fan icon will blink to show that the fryer is heating up and circulating hot air.
8. Sometimes you may need to shake or flip your food midway through the cooking cycle. To do this, pull the pan out of the air fryer by the handle (The air fryer will automatically pause), then carefully shake or flip the ingredients. When done, slide the pan and basket back into the air fryer and resume cooking.

CAUTION: DO NOT PRESS THE BUTTON ON THE HANDLE DURING SHAKING, THIS WILL DETACH THE BASKET FROM THE PAN. If shaking the ingredients in the pan is difficult, place pan on a pot holder, then release and shake the basket.

9. When the cooking time has been reached, the timer will beep five times. After the timer beeps, the fan icon will stop shortly after (Approx. 20 seconds).
10. Pull the pan out of the fryer and place it on a pot holder. NOTE: Oil from the ingredients will gather in the bottom of the pan, be careful when sliding pan out of fryer.

(continued on next page)

## How to use your Air Fryer(continued)

11. To remove the ingredients. Press the fryer basket release button on the handle to free the basket from the pan. Carefully pour ingredients out of the basket and onto a plate.

1. Press fryer basket release button down while pulling up handle to free the basket from the pan

**CAUTION: AFTER COOKING, DO NOT PRESS THE BASKET RELEASE BUTTON UNTIL THE PAN IS PLACED ON A SURFACE.**

\*The GoWISE USA Air Fryer complies with all standards regarding Electro-Magnetic Fields(EMF). Under proper handling, there is no harm caused to the human body based on available scientific evidence.

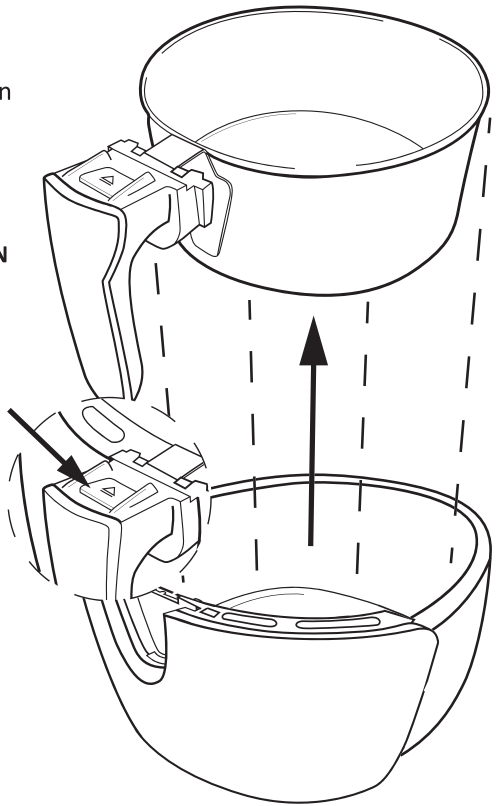

# Cooking Guide

The table on the next page is a guide that will help you with setting the time and temperature for certain ingredients.

NOTE: Please keep in mind that because ingredients differ in size, shape, brand, and origin, we cannot guarantee that this is the best setting for the ingredients you have. However, Rapid Air Technology reheats the air inside the fryer instantly, so pulling the pan out of the fryer for a brief period of time will not interrupt the cooking process.

## TIPS:

- Small ingredients usually require shorter cooking time than larger ingredients.
- Shaking smaller ingredients midway through the cooking process will cook the ingredients more evenly and give you a better result.
- Adding little amount of oil to your ingredients will give you a crispier result.
- Do not cook extremely greasy ingredients, such as sausages in the air fryer.
- Frozen foods or baked goods that can be prepared in the oven can also be prepared in the air fryer.
- The recommended amount of fries is 17.5 oz for preparation.
- Pre-made dough requires shorter cooking time than home-made dough.
- When making cake, quiche, or filled ingredients, use a baking tin or oven dish in the fryer basket.
- You can also use the air fryer to heat ingredients by setting the temperature to 175°F for up to 10 minutes.
- Placing tin foil on the bottom of your basket can make clean up a lot easier.

(continued on next page)

## Cooking Guide(continued)

Food	Time (minutes)	Temperature (°F)	Shake/Flip	Tips
<b>Potatoes &amp; Fries</b>				
Thin Frozen Fries	9-16	400°F	Shake	Add 1/2 Tbsp of Oil
Thick Frozen Fries	11-20	400°F	Shake	
Homemade Fries	16-20	400°F	Shake	
Homemade Potato Wedges	18-22	360°F	Shake	
Homemade Potato Cubes	12-18	360°F	Shake	
Falafel	15	360°F	Shake	
Potato Gratin	15-18	400°F	Shake	
<b>Meat &amp; Poultry</b>				
Steak	8-12	360°F	Flip	Line with tin foil
Pork Chops	10-14	360°F	Flip	
Hamburger	7-14	360°F	Flip	
Sausage Roll	13-15	400°F	Flip	
Drumsticks	18-22	360°F	Flip	
Chicken Breast	10-15	360°F	Flip	
<b>Snacks</b>				
Spring Rolls	8-10	400°F	Shake	
Frozen Chicken Nuggets	6-10	400°F	Shake	
Frozen Fish Sticks	6-10	400°F	Shake	
Frozen Mozzarella Sticks	8-10	360°F	Shake	
Stuffed Vegetables	10	320°F		
<b>Baking</b>				
Cake	20-25	320°F		Use baking tin
Quiche	20-22	360°F		
Muffins	15-18	400°F		

If you have any questions regarding your air fryer, please contact Customer Service at: 1-855-233-9199

## Cleaning your Air Fryer

1. Clean the fryer after every use. Unplug the fryer. ALWAYS WAIT UNTIL THE FRYER HAS COOLED TO A SAFE TEMPERATURE BEFORE HANDLING.
2. Wipe the outside of the fryer with a moist cloth.
3. Clean the pan and the basket with hot water, soap and non-abrasive sponge. You can remove any remaining food debris by using degreasing liquid soap. For any hard-to-get-out or sticking debris, soak the pan in hot water.

NOTE: The basket is dishwasher safe, however, if you would like to clean the basket in the dishwasher, the handle must first be removed by loosening the bolts with a wrench and taking out the screws.

4. Clean the inside of the appliance with a lightly moistened non-abrasive sponge or cloth. Be careful not to get the inside of the appliance too wet.
5. Clean the heating element with a cleaning brush to remove any food debris.

# Troubleshooting

<b>Problem</b>	<b>Possible Cause</b>	<b>Solution</b>
The Fryer is not turning on	The appliance is not plugged in	Plug the appliance into a grounded wall socket
	Basket/pan not pushed in all the way	Slide in the Basket/pan until completely inside the Air Fryer
Ingredients for the fryer are not done	The basket has been over filled with ingredients	Place smaller batches of ingredients in the basket. Smaller batches are fried more evenly
	The set temperature is too low	Increase the temperature settings (see temperature presets in this manual).
The ingredients are fried unevenly in the fryer	Ingredient positioning or overfull	Ingredients that lay on top or across from each other (e.g. fries) need to be shaken midway through cooking
Fried snacks are not crispy after frying	Some snacks are crispier when traditionally fried	brushing a small amount of oil on your ingredients can increase the crispiness
Pan does not slide into fryer properly	Over filled basket	Do not fill the basket beyond the MAX fill indicator line
White smoke comes out from the fryer	It's normal for white smoke to appear when prepping greasy ingredients	When frying greasy ingredients a large amount of oil will leak into the pan. The oil produces white smoke and the pan may heat up more than usual. This does not affect the appliance or end food result
	The pan is still greasy	Clean pan properly after each use
Fresh fries are fried unevenly in the fryer	Potatoes are not fresh	Use fresh potatoes and make sure that they stay firm during frying
	Potato sticks have not been rinsed properly prior to frying	Make sure to rinse the potato sticks properly to remove the starch prior to frying
Fries are not crispy	Oil and water in fries	Potato sticks should be dry prior to adding oil
		Add more oil for a crispier result

# Warranty

## General Warranty (Excluding Refurbished/Auction Items)

GoWISE USA has a 1-year limited warranty for all products. Products are warranted against defects in materials and workmanship for 1-year from the date of purchase, when used in accordance with the instructions provided. This warranty does not cover damages or wear resulting from accident, misuse, abuse, commercial use, or unauthorized adjustment and/or repair.

For all GoWISE USA Pressure Cookers / Smoker, the removable lid and all components (float valve, regulator knob, sealing ring, steam basket, stainless-steel rack, insert pot) are warranted for 30 days from the day of purchase and DO NOT fall under the 1-year limited warranty of the unit.

For all GoWISE USA Air Fryers, the removable basket, tray, and all components are warranted for 30 days from the day of purchase and DO NOT fall under the 1-year limited warranty of the unit.

GoWISE USA® shall not be liable for loss of use or any other incidental, consequential or indirect costs, expenses or damages. There are no express warranties except as listed above. This warranty gives you specific legal rights, and you may have other rights which vary from state to state.

CALL: 1-855-233-9199 for RETURN INSTRUCTIONS.

WE DO NOT SERVICE PRODUCTS OUTSIDE THE 48 CONTINENTAL UNITED STATES. (WE WILL SHIP TO A FREIGHT FORWARDER FOR CUSTOMERS)

NOTE: Customers are responsible for all return shipping costs. When item(s) are returned under warranty as being defective, they are thoroughly tested to verify manufacturer defect. If any item(s) are determined to be in proper working order after testing, all shipping costs to have the product returned to the customer will be the responsibility of the customer

## Return Period: 30 Days

All return requests must be made within 30 days from the date our customers purchase their product(s). Refunds are only applicable during the 30-day return period and may be subject to restocking fees up to 15% of the original purchase amount. If the product is defective within 30 days, GoWISE USA will cover the cost of return shipping, however, a picture and/or video is required to receive a prepaid label. If the product is missing any accessories that were included in the original shipment or the product is damaged,

## Warranty (continued)

altered, or used, the item may no longer be eligible for a refund or replacement. Any decision of refund and/or replacement will be decided at the discretion of GoWISE USA.

NOTE: Customers are responsible for all return shipping costs after 30 days.

### Defective / Freight Damaged:

Products that are within the 30-day return period and have been determined by customer service to be defective are qualified for a return label for the product to be returned to GoWISE USA for inspection and testing. GoWISE USA will provide a return shipping label for defective product(s) only. Customers must contact the Carrier (shipping company) for products that have arrived damaged after initial transit. Clear photographic AND video proof of damage and/or defective products is REQUIRED prior to GoWISE USA authorizing the return of any product.

### Regarding Purchase From 3rd Parties

In order for the GoWISE USA customer service team to look up the warranty information regarding the product(s), the original order information and/or proof of purchase is required. Without this information GoWISE USA will be unable to move forward with providing a replacement under warranty, as we do not know the date or origin of the purchase. GoWISE USA does not have a working business relationship with 3rd party selling sites or services or individuals which are not listed below as one of our Authorized Retailers. GoWISE USA is not responsible for making inquiries to such 3rd parties for the purpose of obtaining documentation. It is the responsibility of the person(s) making the warranty claim to provide original documentation such as order information and/or a receipt so that customer service can process your request. Any claim made under GoWISE USA warranty guidelines must be made by original purchaser of the product(s). Any defective product will be replaced as long as the issues with the device fall within warranty guidelines.

### Authorized Retailers:

- Amazon
- GoWISE USA (Amazon, Sears Marketplace)
- WayFair







## **GoWISEUSA®**

www.gowiseproducts.com  
support@gowiseusa.com  
1-855-233-9199

- To ensure correct use of this appliance, read these instructions carefully and thoroughly.
- Please keep this manual for future reference.
- Thank you for purchasing this GoWISE USA electric Airwise Fryer.

USE PROMO CODE: **LIVewisERAF**

**10%  
OFF**

YOUR NEXT **GoWISEUSA®** PURCHASE



## Free Manuals Download Website

<http://myh66.com>

<http://usermanuals.us>

<http://www.somanuals.com>

<http://www.4manuals.cc>

<http://www.manual-lib.com>

<http://www.404manual.com>

<http://www.luxmanual.com>

<http://aubethermostatmanual.com>

Golf course search by state

<http://golfingnear.com>

Email search by domain

<http://emailbydomain.com>

Auto manuals search

<http://auto.somanuals.com>

TV manuals search

<http://tv.somanuals.com>