



Haier

北京2008年奥运会赞助商
Official Sponsor of the Beijing 2008 Olympic Games

CAUTION

READ THIS MANUAL CAREFULLY TO
DIAGNOSE TROUBLE CORRECTLY
BEFORE OFFERING SERVICE

SERVICE MANUAL

Dehumidifier

**MODEL:HD306,HD456,HD656
HD456E,HD656E**

THIS MANUAL IS USED BY
QUALIFIED APPLIANCE
TECHNICIANS ONLY HAIER
DOES NOT ASSUME ANY
RESPONSIBILITY FOR PROPERTY
DAMAGE OR PERSONAL INJURY
DAMAGE OR PERSONAL INJURY
FOR IMPROPER SERVICE
PROCEDURES DONE BY ONE
UNQUALIFIED PERSON.

REVISION 0

IMPORTANT INFORMATION

Model:HD306,HD456,HD656

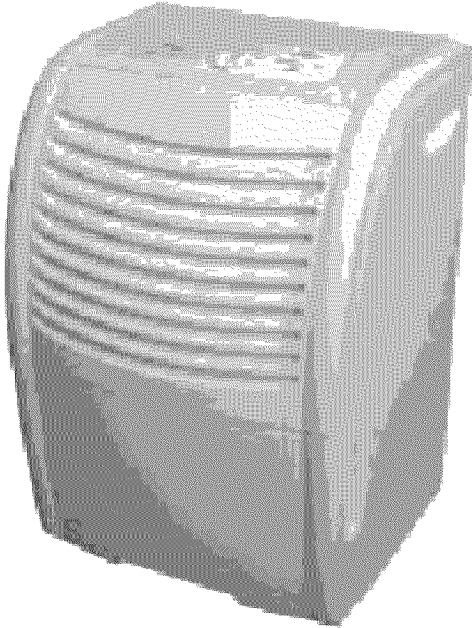

Model:HD456E,HD656E

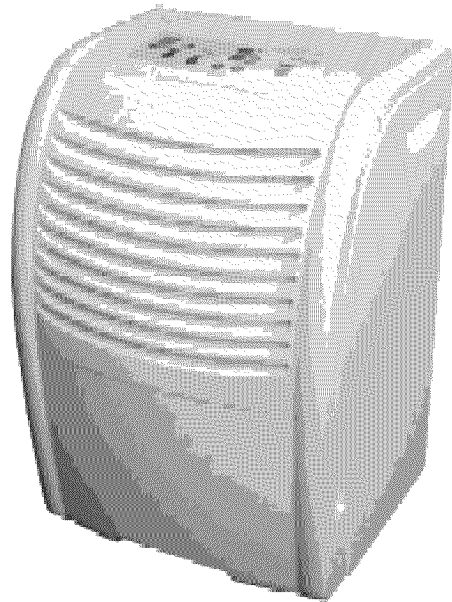

● Features

1. Two Fan Speeds
2. Easy To Control
3. Easy To Empty
4. Easy Clean Air Filter
5. Easy to move
6. Automatic Humidistat Control
7. Automatic Shut off/Indicator Light

● Main Specification

MODEL:HD306,HD456,HD656,HD456E,HD656E

- Capacity(Pints/24hrs) 30/45/65/45/65
- Efficiency(Liter/kwh) 1.2/1.5/1.6/1.5/1.6
- Air flow Rate(CFM)-High/low 150,140/150,140/145,130/150,140/145,130
- Watts(W) 480/550/650/550/650

Safety Information

General Information

This Service Manual describes the operation, disassembly, troubleshooting, and repair of Haier Room Air Conditioners, etc. It is intended for use by authorized servicers who troubleshoot and repair these units.

NOTE: It is assumed that users of this manual are familiar with the use of tools and equipment used to troubleshoot and repair electrical, mechanical, and refrigeration systems; and understand the terminology used to describe and discuss them.

Haier urges you read and follow all safety precautions and warnings contained in this manual. Failure to comply with safety information may result in severe personal injury or death.

Related Publications

This is a base service manual, covering a range of similar models. It is intended to be used in conjunction with the Parts Manual and Technical Sheet covering specific model being serviced.

General Precautions and Warnings

WARNING

To avoid risk of personal injury or death due to electrical shock, disconnect electrical power to unit before attempting to service the unit.

WARNING

To avoid risk of personal injury or death due to electrical shock, **DO NOT**, under any circumstances, alter the grounding plug. Dehumidifier must be grounded at all times. Do not remove warning tag from power cord. If a two-prong (non-grounding) wall receptacle is encountered, contact a qualified electrician and have the receptacle replaced with a properly grounded wall receptacle in accordance with the National Electrical Code.

WARNING

To avoid risk of personal injury or death due to electrical shock, grounding wires and wires colored like grounding wires are **NOT** to be used as current carrying conductors. The standard accepted color coding for ground wires is **green** or **green with a yellow stripe**. Electrical components such as the compressor and fan motor are grounded through an individual wire attached to the electrical component and to another part of the dehumidifier. Grounding wires should not be removed from individual components while servicing, unless the component is to be removed and replaced. It is extremely important to replace all removed grounding wires before completing service.

WARNING

To avoid risk of heat exposure, which may cause death or severe illness, Dehumidifier must be monitored when malfunctions or shuts down.

CONTENTS

1.SPECIFICATION.....	4
2.OPERATION.....	6
3.TROUBLE SHOOTING.....	11
4.ELECTRICAL CONTROLL.....	13
5.CIRCUIT AND WIRING DIAGRAM.....	16

SPECIFICATION

	HD306	HD456	HD656	HD456E	HD656E
Performance					
Capacity - Pints/24hrs	30	45	65	45	65
Efficiency - Liter/kwh	1.2	1.5	1.6	1.5	1.6
Airflow Rate (CFM) - High / Low	150/140	150/140	145/130	150/140	145/130
Noise Level (db) - High / Low	50/45 dB(A)	53/50 dB(A)	55/52 dB(A)	53/50 dB(A)	55/52 dB(A)
Bucket Capacity	25 pt	25pt	25pt	25pt	25pt
Compressor Type	Rotary	Rotary	Rotary	Rotary	Rotary
Refrigerant Type/Charge amount (Oz)	R22/4.41	R22/9.88	R22/10.58	R22/9.88	R22/10.58
Electrical					
Voltage - Frequency (Hz)	115 - 60	115 - 60	115 - 60	115 - 60	115 - 60
Amps	5.8	6	6.6	6	6.6
Watts	480W	550W	650W	550W	650W
Circuit Size (Amps)	5.8	6	6.6	6	6.6
Plug Capacity	125/15	125/15	125/15	125/15	125/15
Plug Type / NEMA#	A / 5-15P	A / 5-15P	A / 5-15P	A / 5-15P	A / 5-15P
Power Cord Length	6'	6'	6'	6'	6'
Dimensions and Installation					
Unit Dimensions (In)					
Height	22 1/4	22 1/4	22 1/4	22 1/4	22 1/4
Width	14 3/8	14 3/8	14 3/8	14 3/8	14 3/8
Depth	13 3/8	13 3/8	13 3/8	13 3/8	13 3/8
Weight (lbs)					
Net / Ship	37.5/41.9	40.8/45.2	43.2/47.6	40.8/45.2	43.2/47.6
Shipping					
Carton Dimensions (In)					
Height	25 3/16	25 3/16	25 3/16	25 3/16	25 3/16
Width	16 5/32	16 5/32	16 5/32	16 5/32	16 5/32
Depth	15 11/32	15 11/32	15 11/32	15 11/32	15 11/32
Container Loading (40' HQ)	696	696	696	696	696

OPERRATION

Model:HD456E,HD656E

Familiarize yourself with the controls on the dehumidifier

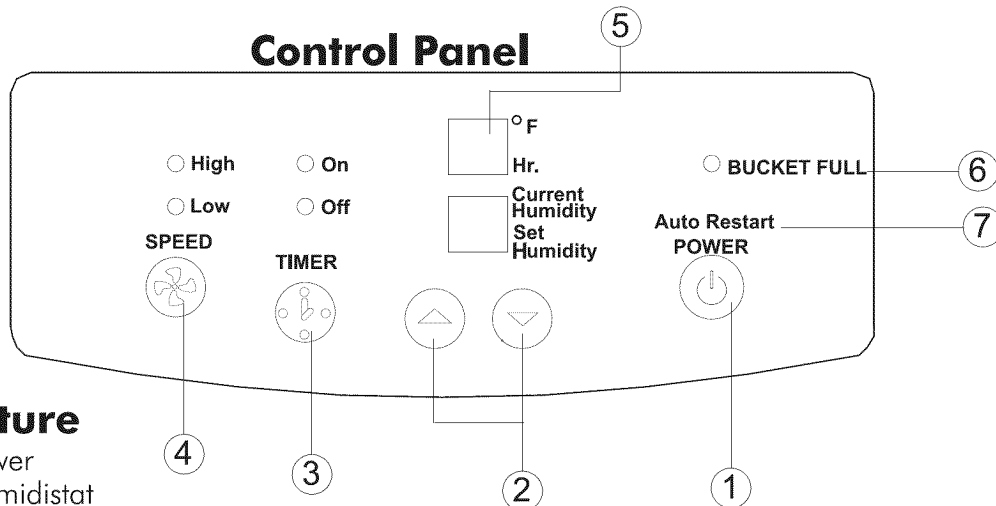

Feature

1. Power
2. Humidistat
This allows you to adjust the humidity of the air. You may set the humidity to your desired by pressing "▲" and "▼" key.
3. Timer
Your air conditioner can be set to go on or off at your desire. This can be done up to 24 hours in advance.
4. Two Fan Speed
When this you can control the fan speed. You have 2 levels of Fan Speed for you to set at you desired level. LOW will circulate air at the lower velocity and HIGH will circulate at the higher velocity.
5. Current Temp/Timer Set Display
When machine is running. It displays the current temperature.
Press the "Timer" button to set the machine to shut off or turn on automatically after a specified amount of time. and it will be the calculagraph.
6. Bucket Full Indicator
When light comes on, automatic flow control stops the unit. Turn the unit off by pressing "POWER" key before emptying the bucket.
7. Auto Restart
Auto Restart will turn the unit on automatically when the power returns
8. Auto-Defrost Sensor (Built in)
When temperature gets down to 60 °F or lower, ice may form on the evaporator coils preventing removal of moisture. The IC stops the compressor when this happens but allows the fan to continue running. When the ice is no longer present it starts the compressor.
9. Current Temp/Timer set Display
When machine is running, it displays the current temperature. Press the "Timer" button to set the machine to shut off or turn on automatically after a specified amount of time, it will be the calculagraph.
10. Current Humidity/Setting humidity Display
It can display the current humidity. If you press the "Adjust humidity" button, the screen will show the humidity you set and be back to show the ambient humidity 5 seconds later.
Setting humidity range: 40%RH~70%RH
Display humidity range: (LO) 30%RH~(HI) 90%RH

Model: HD306, HD456, HD656

Familiarize yourself with the controls on the dehumidifier

Humidity Control

When starting the dehumidifier, turn knob to the right until unit turns on. Adjust knob to desired level of dryness – turn the control knob clockwise for more drying. In the MAX position, the unit will run longer and extract more moisture from the air.

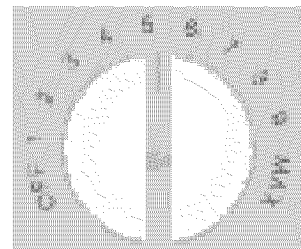

HUMIDITY SETTING

Red Indicator Light

(BUCKET FULL indicator)

When light comes on, automatic flow control turns the unit off. Turn the humidity control off before emptying the bucket.

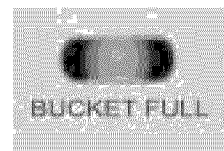

Fan Speed

High speed for higher moisture removal.
Low speed for quieter operation.

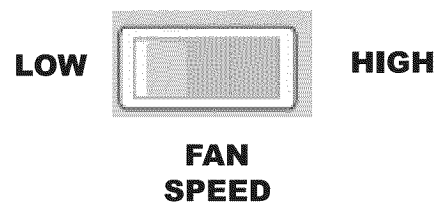

Auto Frost Sensor

(Built in)

When temperature gets down to 60°F or lower, ice may form on the evaporator coils preventing removal of moisture. The FROST CONTROL stops the compressor when this happens but allows the fan to continue running. When the ice is no longer present it starts the compressor.

Features/Care & Cleaning

It is normal for the surrounding air to become slightly warmer as the dehumidifier operates. This warming effect further reduces the relative humidity of the surrounding air.

There are 2 ways to remove collected water.

1. Using the bucket

When the bucket is full, the red indicator light, "BUCKET FULL," will go on.

You must turn the humidity control off before removing the bucket. Wait a few minutes to allow the water to stop dripping. Use both side handles to lift and remove bucket. Pour water through opening and replace bucket. (See Fig.1)

Note: All models are equipped with built-in water overflow control. The unit will shut down when the water level reaches a maximum level in the bucket. This prevents the bucket from overflowing. The maximum water level can be adjusted by lifting the red plunger located on the top of the bucket.

Turning the plunger clockwise about two turns will raise the water level. Turning it anti-clockwise will lower the maximum water level.

Warning:

Make sure the drain cap be tightened before running the unit.

Using the bucket

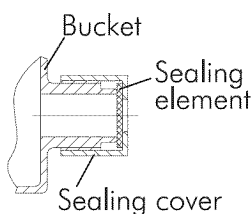

Using a hose

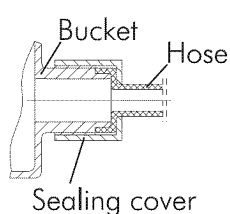

2. Use continuous drainage:

The water can be drained out continuously through a long hose that connects to the bottom of the bucket.

Remove the bucket and remove the plastic cap on the bottom of bucket. Then take the rubber insert out of the cap (Keep the rubber insert well for use later). See Fig.#1

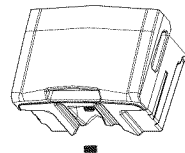
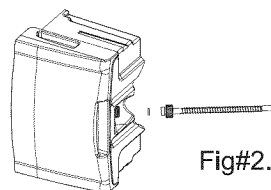

Fig.#1

Using the supplied hose, Thread the hose through the cap opening and add the washer to the cap. Screw the cap to the threaded matng connector on the bucket. Make sure to use the washer or the connection may leak.

See Fig#2.



Fig#2.

Thread the hose through the round hole and extend the hose to the back of the unit.

See Fig#3

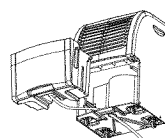

Fig #3

Place the bucket in its original position.

Features/Care & Cleaning

Proper use and care

- Place the dehumidifier in a location that does not restrict air flow into the rear coil or out the front grille.
 - The dehumidifier must be operated in an enclosed area to be most effective. Close all doors, windows and other outside openings to the room.
 - A dehumidifier operating in a basement will have little or no effect in drying an adjacent enclosed storage area, such as a closet, unless there is adequate circulation of air in and out of the area.
 - When you use the new model the first time, if the "BUCKET FULL" light highlights, then you can take the bucket out and put it in again, the light will die.
- Turn the dehumidifier off and remove the plug from the wall outlet before cleaning. Use water and a mild detergent to clean the inlet and outlet grilles. Do not use bleach or abrasives. The air filter is on the front of the dehumidifier. It should be checked and cleaned at least every 2 to 3 weeks or when needed. To remove filter: Unplug the unit, remove the bucket and lift out the filter. Clean the filter with a vacuum cleaner or wash it with clean water and dry it with a dry cloth.

TROUBLE SHOOTING

If your Dehumidifier does not work as expected

Before calling read the following section first.

It will help you solve the most common problems that might occur and which can be easily corrected.

If all efforts fail and you need service, a toll free number is available please use it to contact our customer service.

Items to check before calling for service:

Unit not operating

- Make sure the plug is pushed completely into the outlet.
- The fuse is blown or circuit was tripped. Check the house fuse/circuit breaker. Replace fuse or reset circuit breaker.
- The bucket is full. The dehumidifier automatically turns off when this occurs. The drain bucket needs to be emptied.
- When the ambient temperature is above 122F or below 32F, the model will restart after shutting off 3 minutes in order to protect the compressor.

Dehumidifier is icing up during initial stage of operation

- This is normal. Frost will usually disappear within 60 minutes unless temperature is below 60°F. This is normal for the dehumidifier.

Airflow is restricted

- Make sure there are no curtains, blinds or furniture blocking the front or back of the dehumidifier.

Additional note: After prolonged usage, the condenser coils behind the filter may develop a buildup of residual. Unless cleaned regularly with a soft brush, this residual will harden through time and may require special cleaning methods by a refrigeration/air-conditioning serviceman.

Unsatisfactory dehumidification

When first installed, allow at least 3 or 4 days to remove the moisture from the room to maintain the desired dryness.

- Area to be humidified is too large. Check with dealer that model is suitable for room size and moisture level.
- The controls may not be set correctly. Adjust controls according to instructions.
- Doors and windows may not be closed. Check that all doors, windows and other openings are closed tightly and bot open.
- Clothes dryer may be in operation in the same room. Install the dehumidifier away from the moisture-laden air generated by the dryer. Dryer should be vented to the outside.
- Room temperature too low. The unit will not operate satisfactorily if the room temperature is below 60°F.

CIRCUIT AND WIRING DIAGRAM

Mode :HD306,HD456,HD656

WIRING DIAGRAM

0010558180

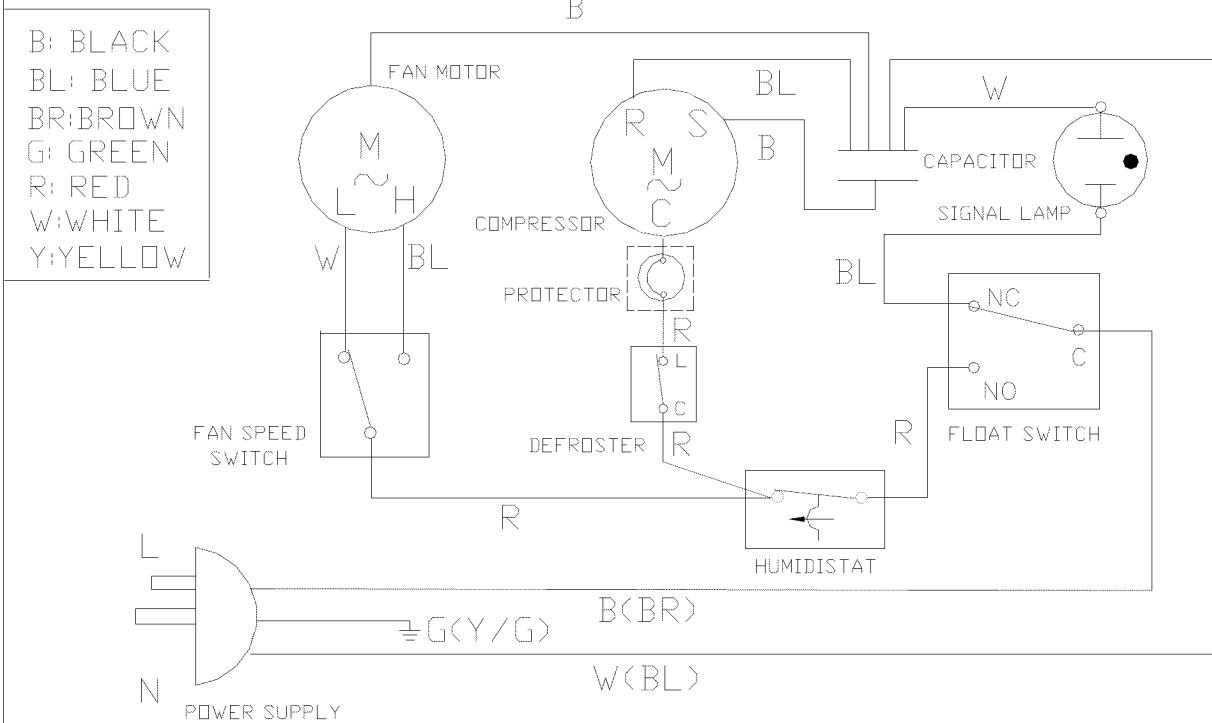

Mode I:HD456E,HD656E

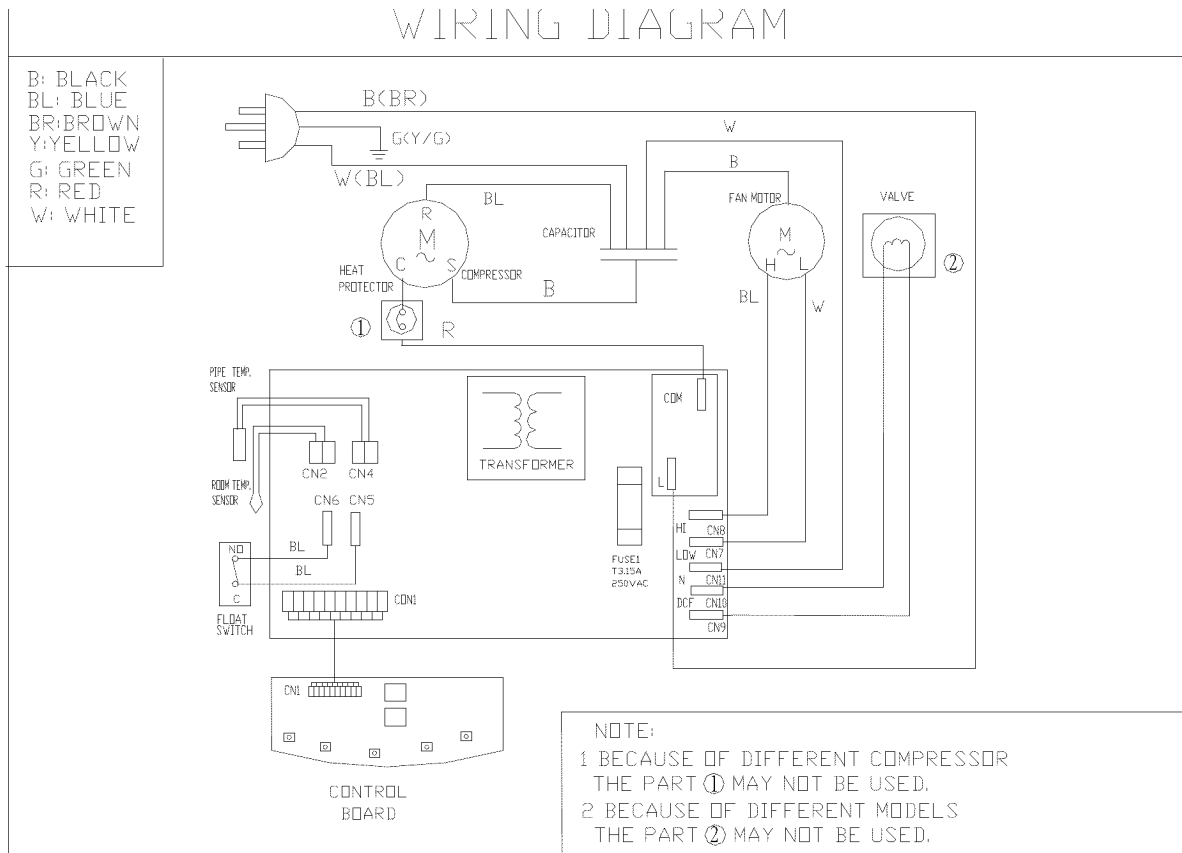

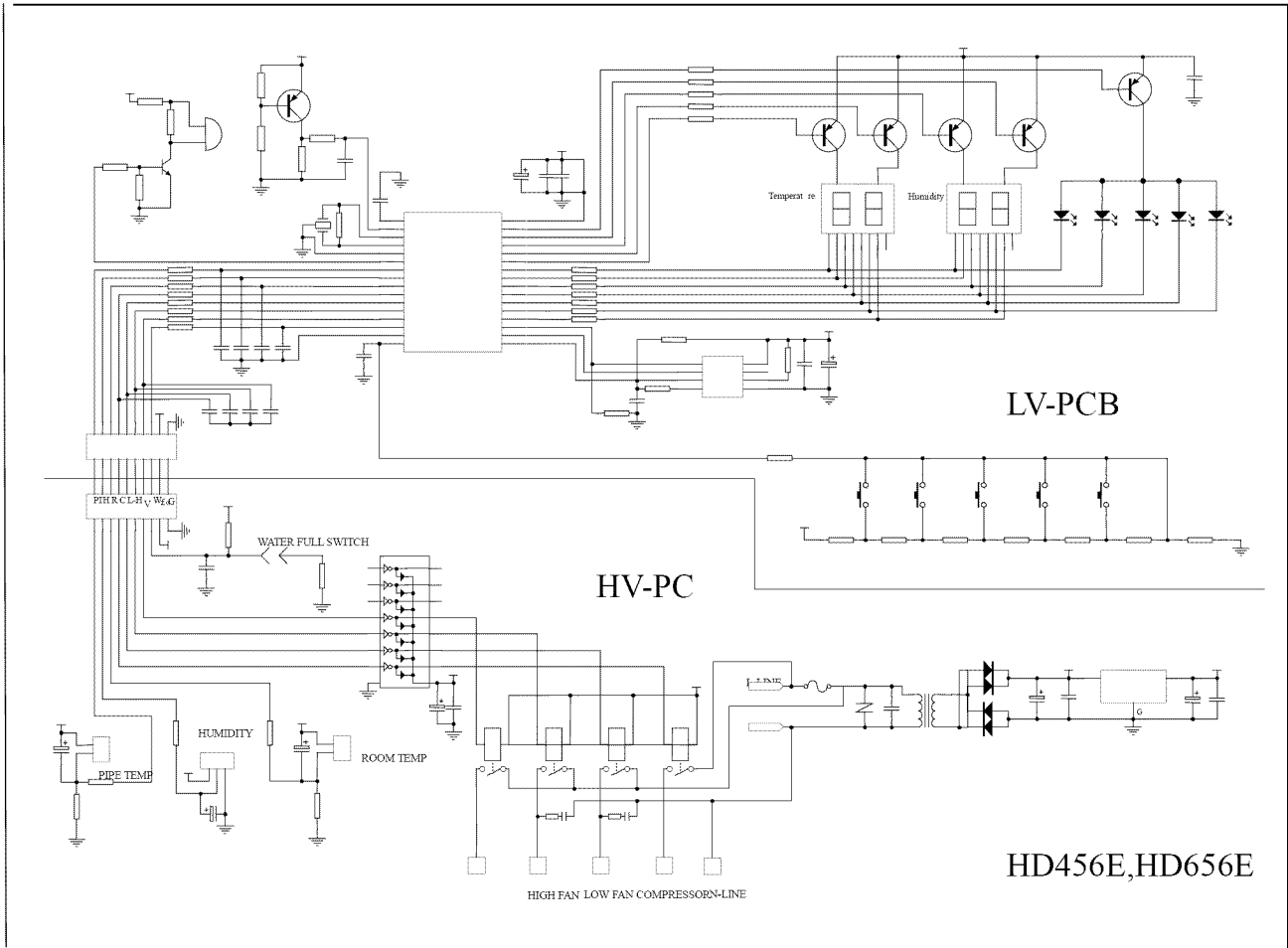

Sincere Forever

Haier Group

Haier Industrial Park, No.1, Haier Road

266101, Qingdao, China

<http://www.haier.com>

Free Manuals Download Website

<http://myh66.com>

<http://usermanuals.us>

<http://www.somanuals.com>

<http://www.4manuals.cc>

<http://www.manual-lib.com>

<http://www.404manual.com>

<http://www.luxmanual.com>

<http://aubethermostatmanual.com>

Golf course search by state

<http://golfingnear.com>

Email search by domain

<http://emailbydomain.com>

Auto manuals search

<http://auto.somanuals.com>

TV manuals search

<http://tv.somanuals.com>