

HITACHI

SERVICE MANUAL

SM0557

CP-S240WF(CC9SM)

CP-X250WF(CC9XM)

ED-X8250(CC9XM)

⚠ Warning

The technical information and parts shown in this manual are not to be used for: the development, design, production, storage or use of nuclear, chemical, biological or missile weapons or other weapons of mass destruction; or military purposes; or purposes that endanger global safety and peace. Moreover, do not sell, give, or export these items, or grant permission for use to parties with such objectives. Forward all inquiries to Hitachi Ltd.

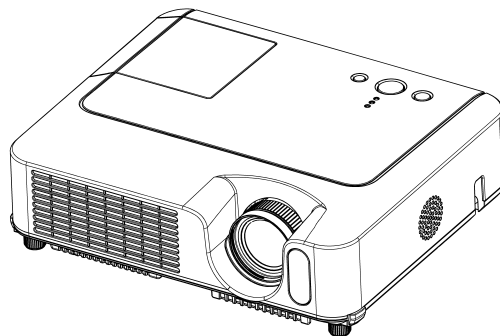

Caution

Be sure to read this manual before servicing. To assure safety from fire, electric shock, injury, harmful radiation and materials, various measures are provided in this Hitachi Multimedia LCD Projector. Be sure to read cautionary items described in the manual to maintain safety before servicing.

Service Warning

1. When replacing the lamp, avoid burns to your fingers, the lamp becomes very hot.
2. Never touch the lamp bulb with a finger or anything else. Never drop it or give it a shock, they may cause bursting of the bulb.
3. This projector is provided with a high voltage circuit for the lamp. Do not touch the electric parts of power unit (circuit) and power unit (ballast), after turning on the projector.
4. Do not touch the exhaust fan during operation.
5. The LCD module assembly is likely to be damaged. If replacing the LCD LENS/PRISM assembly, do not hold the FPC of the LCD module assembly.
6. Use the cables which are included with the projector or as specified.

Contents

1. Features -----	2	8. Disassembly diagram-----	37
2. Specifications-----	2	9. Replacement parts list-----	44
3. Names of each part-----	3	10.RS-232C commands -----	46
4. Adjustment -----	6	11.Block diagram -----	55
5. Troubleshooting-----	12	12.Connector connection diagram -----	56
6. Service points -----	17	13.Basic circuit diagram-----	57
7. Wiring diagram -----	30		

SPECIFICATIONS AND PARTS ARE SUBJECT TO CHANGE FOR IMPROVEMENT.

Multimedia LCD Projector

August 2005 Digital Media Division

CP-S240(CC9SM)/CP-X250(CC9XM)

1. Features

- High Brightness
- Low Noise
- Rich Connectivity
- Compact Body

2. Specifications

		CP-S240	CP-X250	
Liquid crystal panel	Drive system	TFT active matrix		
	Panel size	1.5cm(0.6 type)		
	Number of pixels	800 (H) x 600 (V)	1024 (H) x 768 (V)	
Lamp		180W UHB		
RGB signal	RGB IN	1	Video : Analog 0.7Vp-p(75Ω termination) H/V. sync. : TTL level (positive/negative) Composite sync. : TTL level	
		2*		
	RGB OUT*	Video:Analog 0.7Vp-p, 75Ω output impedance (positive) H/V. sync.: TTL level (positive/negative) Composite sync.: TTL level		
VIDEO signal	VIDEO IN	1.0Vp-p (75Ω termination)		
	S-VIDEO IN	Y signal: 1.0±0.1Vp-p, (75Ω termination) C signal: 0.286±0.1Vp-p (NTSC burst signal, 75Ω termination) 0.3±0.1Vp-p (PAL/SECAM burst signal, 75Ω termination)		
	COMPONENT VIDEO	Y	1.0±0.1Vp-p, 75Ω termination (positive)	
		C _B /P _B	0.7±0.1Vp-p, 75Ω termination (positive)	
C _R /P _R		0.7±0.1Vp-p, 75Ω termination (positive)		
AUDIO signal	AUDIO IN 1	200mVrms, 47kΩ or more (max. 3.0Vp-p)		
	AUDIO IN 2 L/R	200mVrms, 47kΩ or more (max. 3.0Vp-p)		
	AUDIO OUT	0~200mVrms, output impedance 1kΩ (max. 5.0Vp-p)		
Speaker output		1W x 1		
Power supply		AC100~120V/3.1A, AC220~240V/1.7A		
Power consumption		290W		
Dimensions		306 (W) x 86 (H) x 249 (D) mm (Not including protruding parts)		
Weight		2.8kg		
Temperature range		Operation : 5~35°C Storage : -20~60°C		
Accessories		Remote control x1 RGB cable x 1 Audio/Video cable x 1 Power cords x 3	Batteries x 2 User's manuals x 1 Soft case x 1	

*) This port is used as both RGB IN 2 and RGB OUT. Its function is selected with RGB IN/OUT switch.

3. Names of each part

● Projector

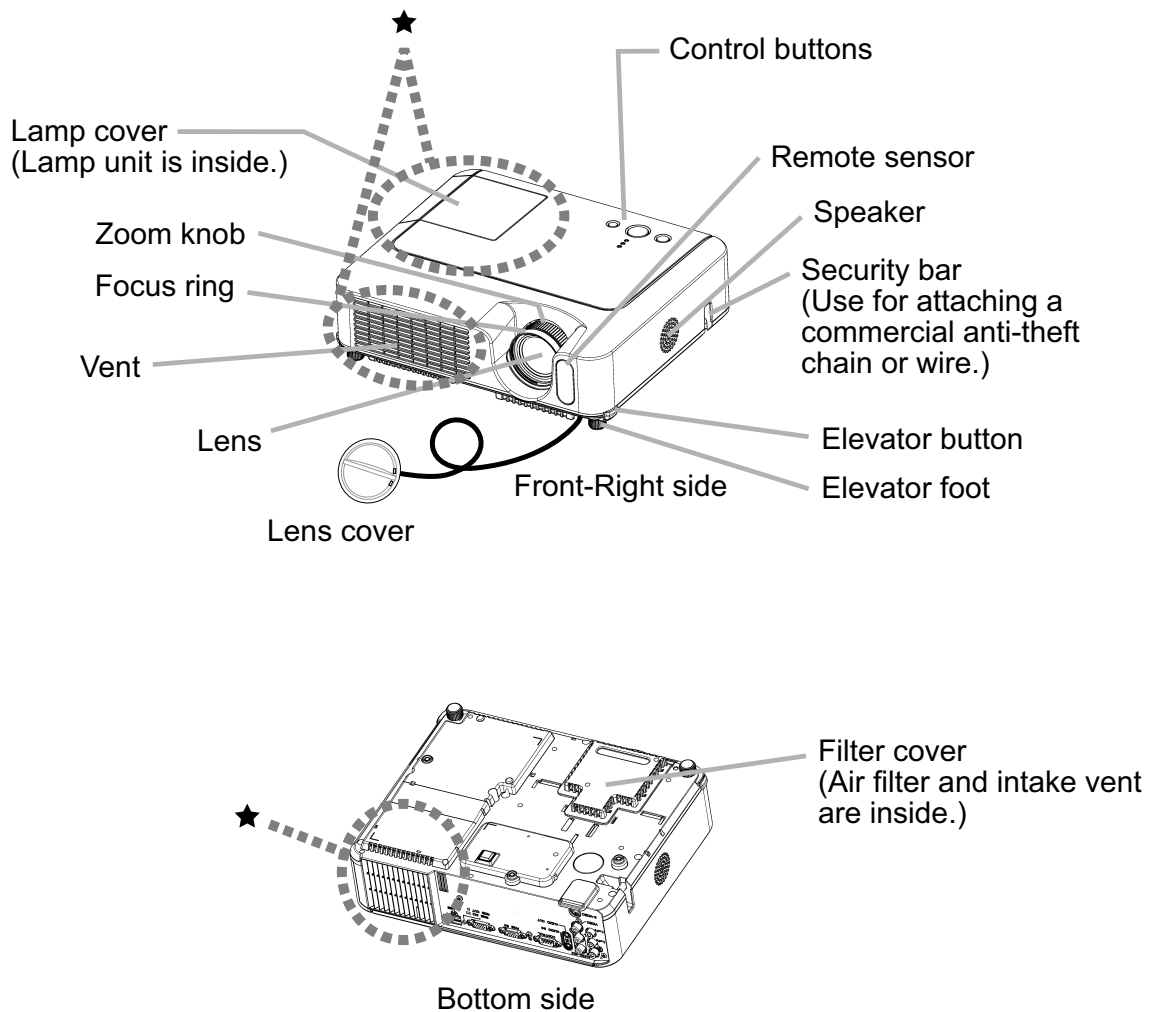

⚠ WARNING

During use or immediately after use, do not touch around the lamp and vents of the projector. (★) It could cause a burn.

CP-S240(CC9SM)/CP-X250(CC9XM)

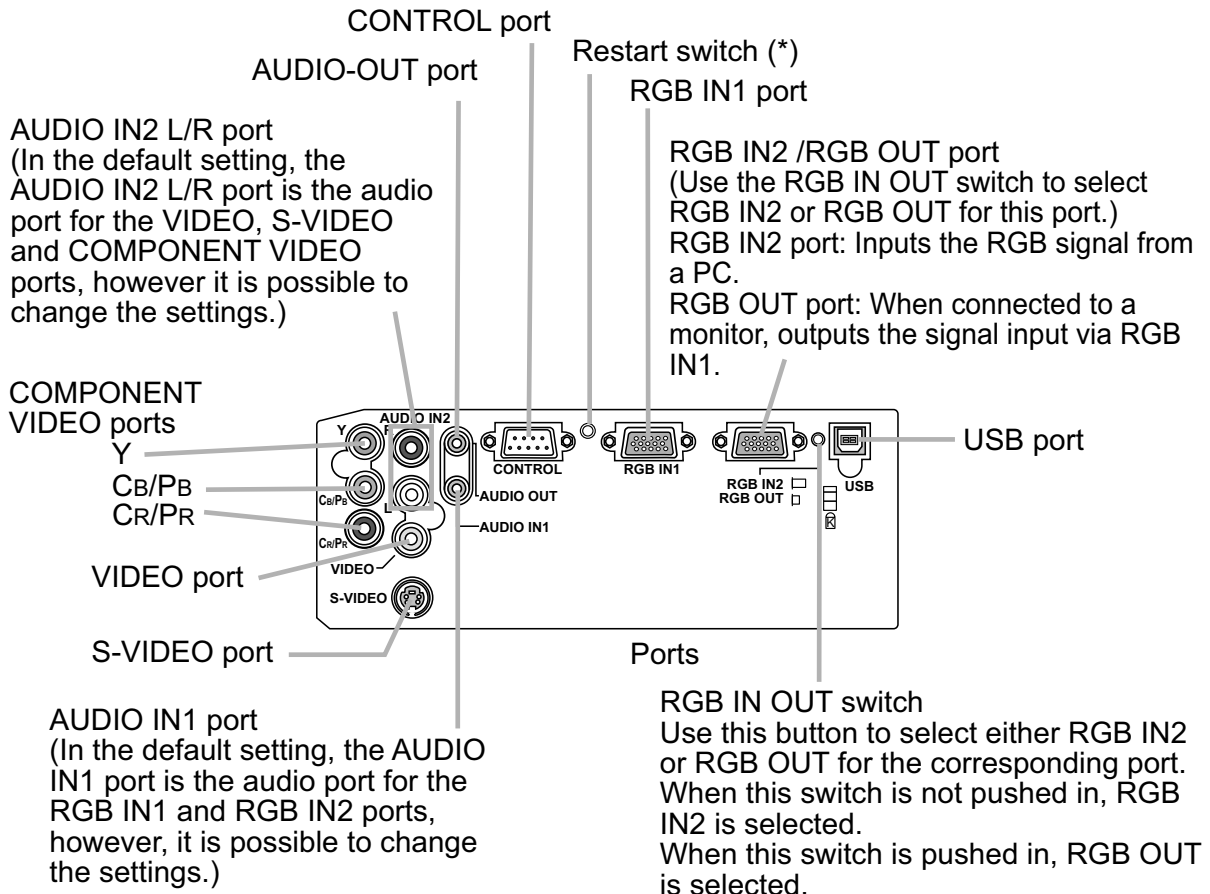
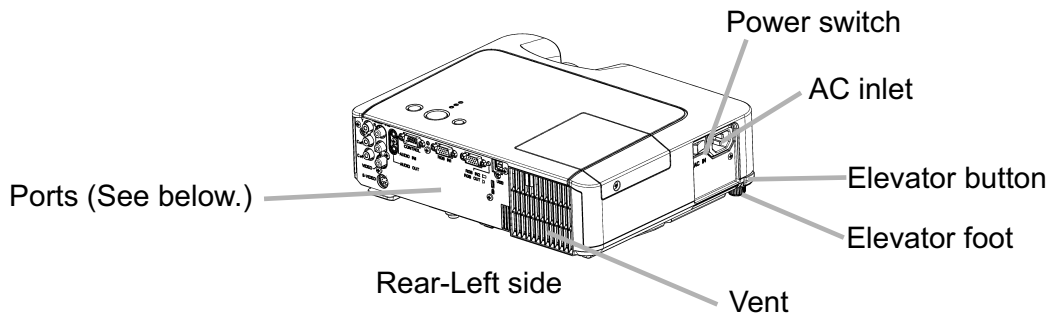

NOTE (*) About Restart switch: This projector is controlled by an internal microprocessor. Under certain exceptional circumstances, the projector may not operate correctly and the microprocessor will need to be reset. In such a case, please push the Restart switch by using a cocktail stick or similar, and before turning on again, make the projector cool down at least 10 minutes without operating. Only push the Restart switch in these exceptional instances.

Control buttons

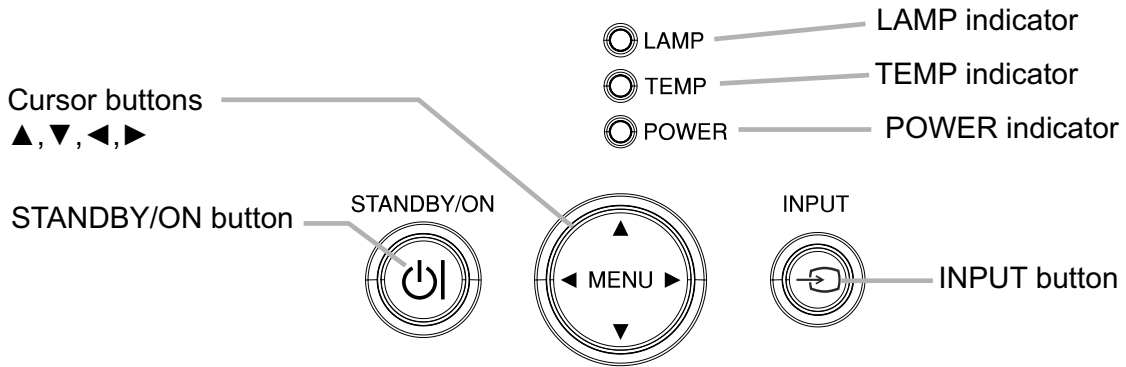

Remote control

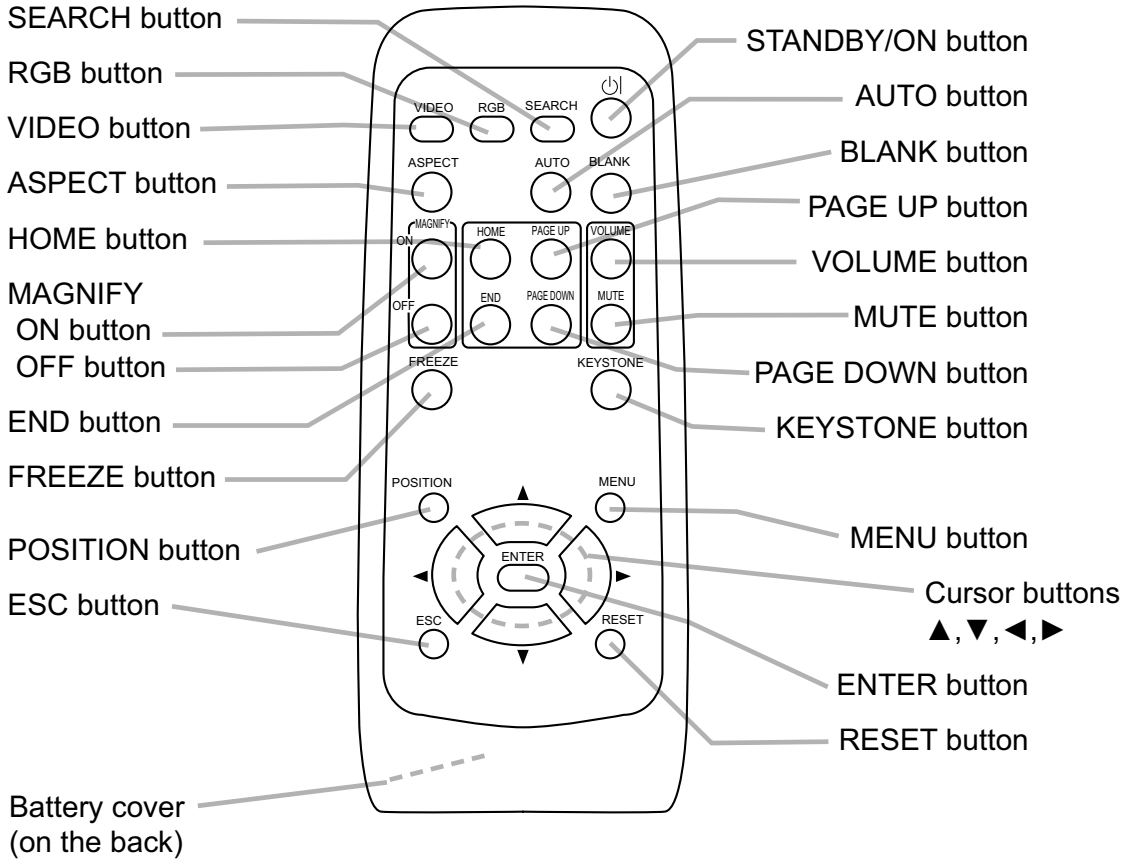

4. Adjustment

4-1 Before adjusting

4-1-1 Selection of adjustment

When any parts in the table 4-1 are changed, choose the proper adjusting items with the chart.

Table 4-1: Relation between the replaced part and adjustment

Replaced part	Adjustment				
	Convergence (Chap.4-2)	Ghost (Chap.4-3)	Flicker (Chap.4-4)	White balance (Chap.4-5)	Color uniformity (Chap.4-6)
Dichroic optics unit	△	×	○	△	○
LCD/LENS prism assembly	○	○	○	○	○
PWB assembly Main	○	○	○	○	○
Lamp unit assembly	×	×	△	△	△

○ : means need for adjustment. × : means not need for adjustment.
△ : means recommended.

4-1-2 Setting of condition before adjustment

1. Before starting adjustment, warm up projector for about 10 minutes.
2. Set Zoom Wide to Max. And project an image with more than 1m (40 inches) in diagonal size.
3. Normalizing the video adjustment
Press the [MENU] button to display the Easy menu. If Advance menu comes up, move to the Easy menu.
Select RESET in the Easy menu and press **▶** or [ENTER] button to open the RESET menu window. Choose EXECUTE with **▲** button.
Note that no signal input may not allow to reset the adjustments.
4. Select PICTURE > GAMMA in the Advance menu to set to DEFAULT1.
Note that PICTURE menu is not selectable with no signal input displayed.
5. Select PICTURE > COLOR TEMP > CUSTOM in the Advance menu, then press **▶** or [ENTER] button to display the equalizing window. Set all the values of OFFSET and GAIN in the window to zero.

Caution: Before this performance, make a note of your customer's adjustments, because the data is overwritten.

6. Perform all adjustments from the FACTORY MENU.

Perform the following operations to display the FACTORY MENU.

< When you use the remote control... >

- a. Press the [MENU] button of remote control to display the Easy menu. (If the Advance menu appears, move to the Easy menu from EASY MENU.)
- b. Select the [RESET] in the Easy menu, and then press the **▶** or [ENTER] button.
- c. Next, press the [RESET] button one time. And hold the [RESET] button for 3 seconds or more (the FACTORY MENU will appear).

< When you use the keypad... >

- a. Press the **▲**/[▼]/[◀]/[▶] button of the projector to display the Easy menu. (If the Advance menu appears, move to the Easy menu from EASY MENU.)
- b. Select the [RESET] in the Easy menu, and then press the **▶** button.
- c. Next, press the [▼] button one time. And repress and hold the [▼] button together with the [INPUT] button for 3 seconds or more (the FACTORY MENU will appear).

4-2 Convergence adjustment

Signal pattern for internal adjustment

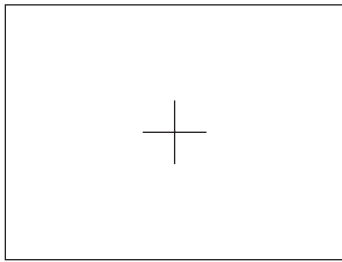

Adjustment procedure

Perform this adjustments only when the convergence is not good.

1. Open FACTORY MENU and then select OPTION > CNV-V. Use R and/or B so that three colors of images can be converged at center, top and bottom of the screen.
2. In the same way, select OPTION > CNV-H and use R and/or B so that three colors of images can be converged at center, left and right of the screen.

4-3 Ghost adjustment

Signals for internal adjustment

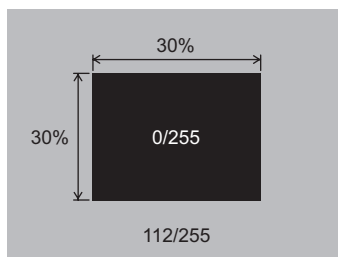

Adjustment procedure

1. Make this adjustment after completing the adjustment in 4-2.
2. Choose Advance menu > OPTION > SERVICE > GHOST > R,G and B, and set them to zero.
3. Open the FACTORY MENU and choose DAC-P > GHOST > R,G and B to display each color of test patterns for adjustments.
Confirm if there is ghosting on the both sides of black pattern. If visible, perform this adjustment as following procedure.
4. Use DAC-P - GHOST - R: in the FACTORY MENU to adjust so that R color ghost is at a minimum.
(Set the adjustment value to default, and then raise the value. When a ghost appears to the left of a vertical line, reduce the value by 3 steps. Then, if a ghost image is visible on the right of an original image, raise the number by 1 step.)
5. In the same way, use DAC-P - GHOST-G: in the FACTORY MENU to adjust so that G color ghost is at a minimum.
6. In the same way, use DAC-P - GHOST-B: in the FACTORY MENU to adjust so that B color ghost is at a minimum.

4-4 Flicker adjustment (V.COM adjustment)

Signals for internal adjustment

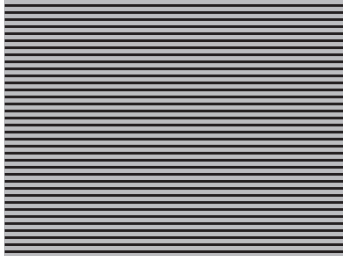

Adjustment procedure

1. Make this adjustment after completing the adjustment in 4-3 Ghost adjustment.
2. Use DAC-P - V.COM - R: in the FACTORY MENU to adjust so that the flicker at the center of the screen is less than the flicker at the periphery. (When the flicker is about the same across the whole screen, adjust so that the flicker at the center of the screen is somewhat less than elsewhere.)
3. In the same way, use DAC-P - V.COM-G: in the FACTORY MENU to adjust the G color flicker.
4. In the same way, use DAC-P - V.COM-B: in the FACTORY MENU to adjust the B color flicker.

4-5 White balance adjustment (visual inspection)

Preparations

1. Perform these adjustments after the Flicker adjustment described in Section 4-4.

Adjustment procedure

1. First, adjust the G color.
2. Select GAMMA, SUB-CNT, and G: in the FACTORY MENU. If the background is white solid, press the [ENTER] key on the Remote control transmitter to change to [G] monochrome in the 33-tone grayscale.
3. Adjust GAMMA, SUB-CNT, and G: in the FACTORY MENU so that brightness of 33 steps is best.
4. Don't adjust GAMMA, SUB-BRT, and G: in the FACTORY MENU. Because we want to keep the best contrast ratio.
5. Then adjust colors R and B.
2. Reset gamma correction before adjustment.
 - Place the cursor on [GAMMA] in the FACTORY MENU, press the [RESET] key and select [DEFAULT].
6. Select GAMMA, SUB-CNT, and G: in the FACTORY MENU. If the background is white solid, press the [ENTER] key on the Remote control transmitter to change to [W] monochrome in the 33-tone grayscale.
7. Adjust GAMMA, SUB-BRT, R: and B: in the FACTORY MENU so that low-brightness white balance is best.
8. Adjust GAMMA, SUB-CNT, R: and B: in the FACTORY MENU so that middle-brightness white balance is best.
9. Repeat steps 7 to 8 above, and adjust so that brightness white balance of 33 steps is best.

4-6 Color uniformity adjustment

Preparations

- Perform these adjustments after the white balance adjustment described in Section 4-5.
- Make a color uniformity adjustment for the following four tones.
 - MIN tone (approx. 7% input signal)
 - MID-L tone (approx. 14% input signal)
 - MID-H tone (approx. 46% input signal)
 - MAX tone (approx. 70% input signal)
- Place the cursor on [C.UNIF.] in the FACTORY MENU and press the **[▶]** key. This displays the Adjust Tone menu at the bottom of the screen. To choose the tone to be adjusted, press the **[▶]** key and then use the **[▲]** or **[▼]** key. Select the major adjustment lattice point No. and color, and then adjust them.
- The major adjustment lattice point numbers (a total of 17 points) corresponds to the major adjustment lattice point positions in the diagram on the right. The color uniformity of the entire screen can be adjusted by adjusting the white balance for each of the points starting in order from the low numbers.
- Adjustment point No.1 should not be adjusted, because it controls the brightness of the entire screen.
- To temporarily turn correction off, place the cursor on [C.UNIF.] in the Adjust Tone menu and press the **[▼]** key. The ON/OFF menu appears. Place the cursor on [ON] with the **[▶]** key and press the **[▼]** key. To turn it on again, place the cursor on [OFF] and press the **[▲]** key.
- Although this adjustment can also be made using internal signals, we will here use the **[ENTER]** key on the Remote control transmitter to select the following two signals.
 - Solid monochrome adjustment color (use G color adjustment when a color differential meter is used).
 - Solid white (use for adjustment other than above).
- Reset color-shading correction before adjustment.
 - When 4 tones and all colors are to be reset, place the cursor on [C.UNIF.] in the FACTORY MENU, press the **[RESET]** key and select **[DEFAULT]**.
 - When only 1 tone is to be reset, place the cursor on the tone to be reset, press the **[RESET]** key and select **[DEFAULT]**.
 - Single tone and monochrome resets cannot be performed.

FACTORY MENU

VID-AD
C. UNIF.
DAC-P
GAMMA
STRIPE
OPTION

Adjust tone menu

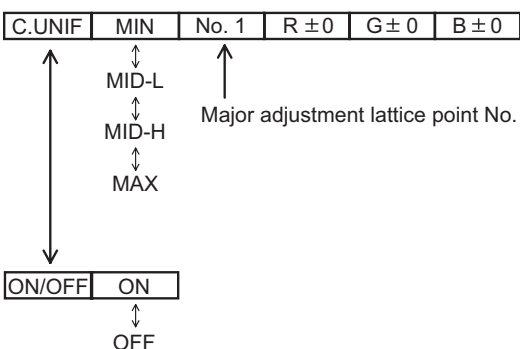

Major adjustment lattice point position

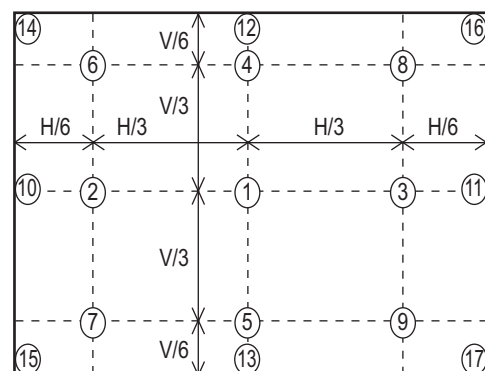

Adjustment procedure 1

(When a color differential meter is used)

1. First adjust [MID-L] tone [G:].
2. Select adjustment point [No.2][G:].
When the background is not [G] monochrome, press the [ENTER] key on the Remote control transmitter to change to solid [G] monochrome.
3. Measure the illumination at adjustment points No. 2, No.3, No.10 and No.11.
The values should be:
No.2 = Y2 [lx] No.10 = Y10 [lx]
No.3 = Y3 [lx] No.11 = Y11 [lx]
4. No.2 and No.3 adjustment point have the average of Y2 and Y3.
 $Y2 = (Y2 + Y3) / 2 \pm 2 [\%]$
 $Y3 = (Y2 + Y3) / 2 \pm 2 [\%]$
5. No.10 and No.11 adjustment point have the average of Y10 and Y11.
 $Y10 = (Y10 + Y11) / 2 \pm 2 [\%]$
 $Y11 = (Y10 + Y11) / 2 \pm 2 [\%]$
6. Then adjust [MID-L] tone [R] and [B].
When the background is [G] monochrome, press the [ENTER] key on the Remote control transmitter to change to solid white.
7. Measure the color coordinates of adjustment point [No.1] and make a note of them.
Assume that they are $x = x1$, $y = y1$.
Note: When the CL-100 color and color difference meter is used, the $[\Delta]$ (delta) mode is convenient. When adjustment point [No.1] color coordinate has been selected, set the slide switch on the side to $[\Delta]$ (delta) while holding down the [F] button on the front panel. The measurement shown after this displays the deviation from measurement point 1.
8. Measure the color coordinates of measurement point [No.2] and adjust [No.2][R:] and [B:] so that the coordinates are as follows.
 $x = x1 \pm 0.005$, $y = y1 \pm 0.010$
9. Similarly, measure adjustment points [No.3] to [No.17] and adjust their color coordinates starting in order from the small number points.
This completes adjustments required for [MIN].
Note: Since excessive correction may lead to a correction data overview during internal calculations, use the following values for reference.
[No.2] to [No.5] ± 40 or less
[No.6] to [No.9] ± 50 or less
[No.10] to [No.13] ± 70 or less
[No.14] to [No.17] ± 120 or less
10. Then adjust [MIN] tone [G] so that the adjustment data set two times as much as [MID-L] tone [G].
This completes [G] color adjustments.
11. Then adjust [MIN] tone [R] and [B].
Select [No.2] [B:] and press the [ENTER] key on the Remote control transmitter to change to solid white.
12. Measure the color coordinates of adjustment point [No.1] and make a note of them.
Assume that they are $x = x1$, $y = y1$.
13. Now measure the color coordinates of measurement point [No.2] and adjust [No.2][R:] and [B:] so that the coordinates are as follows.
 $x = x1 \pm 0.005$, $y = y1 \pm 0.010$ (Target)
 $x = x1 \pm 0.020$, $y = y1 \pm 0.040$
14. Similarly, measure adjustment points [No.3] to [No.17] and adjust their color coordinates starting in order from the small number points.
This completes [MIN] tone adjustments.
15. Now make similar adjustments for [MID-H] tone.
(Adjust [MID-H] tone [G] so that the adjustment data set half as many as [MID-L] tone [G].)
16. Now make similar adjustments for [MAX] tone.
(Adjust [MAX] tone [G] so that the adjustment data set half as many as [MID-L] tone [G].)

Adjustment procedure 2

(visual inspection)

1. First adjust [MIN] tone [G:].
2. Select [No.2] [G:].
If the background is [G] monochrome, press the [ENTER] key on the Remote control transmitter to change to solid white.
3. View measurement point [No.2] and [No.3].
Lower the [G] color intensity only of the color point whose [G] color is more intense than measurement point [No.1].
4. View measurement point [No.10] and [No.11].
Lower the [G] color intensity only of the color point whose [G] color is more intense than measurement point [No.1], and raise the intensity of the point whose color intensity is lower than measurement point [No.1].
5. Now adjust the [MIN] tone for colors [R] and [B].

6. View measurement points [No.2], [No.3], [No.10] and [No.11]. Adjust the [R] and [B] of each measurement point so that they have the same color as measurement point [No.1].

Adjustment technique:

First, adjust [B:] of the point whose color is to be adjusted so that it approximates that of [No.1]. If [R:] is low at this time, the image will have cyan cast, in which case [R:] is increased. On the other hand, if [R:] is excessive, the image will have a magenta cast, in which case [R:] is decreased.

Overall, a cyan cast makes it easy to see color shading.

7. Next, view measurement points [No.4], [No.5], [No.12], [No.13] and make similar adjustments.
8. Then adjust measurement points [No.6], [No.7], [No.8], [No.9], [No.14], [No.15], [No.16] and [No.17]. This completes the [MIN] tone adjustments.
9. Make similar another three tones as described in steps 1 to 8 above.

No. 2 deviation range

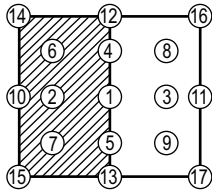

No. 10 deviation range

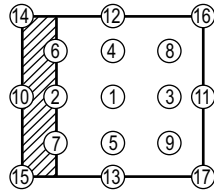

No. 3 deviation range

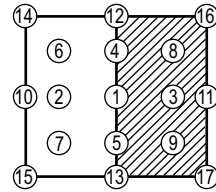

No. 11 deviation range

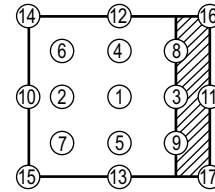

No. 4 deviation range

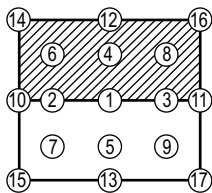

No. 12 deviation range

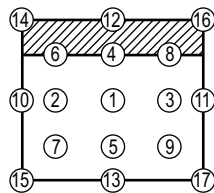

No. 5 deviation range

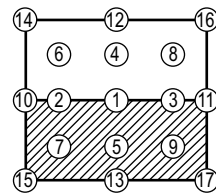

No. 13 deviation range

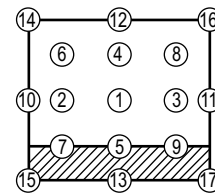

No. 6 deviation range

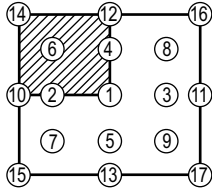

No. 7 deviation range

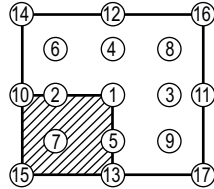

No. 8 deviation range

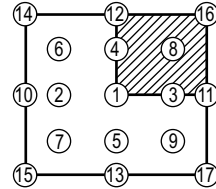

No. 9 deviation range

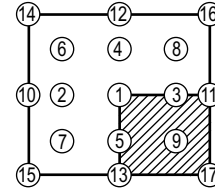

No. 14 deviation range

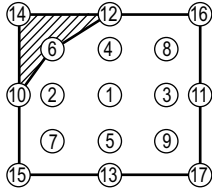

No. 15 deviation range

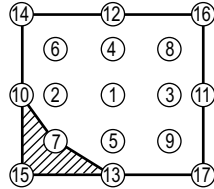

No. 16 deviation range

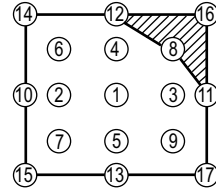

No. 17 deviation range

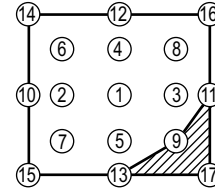

5. Troubleshooting

Check points

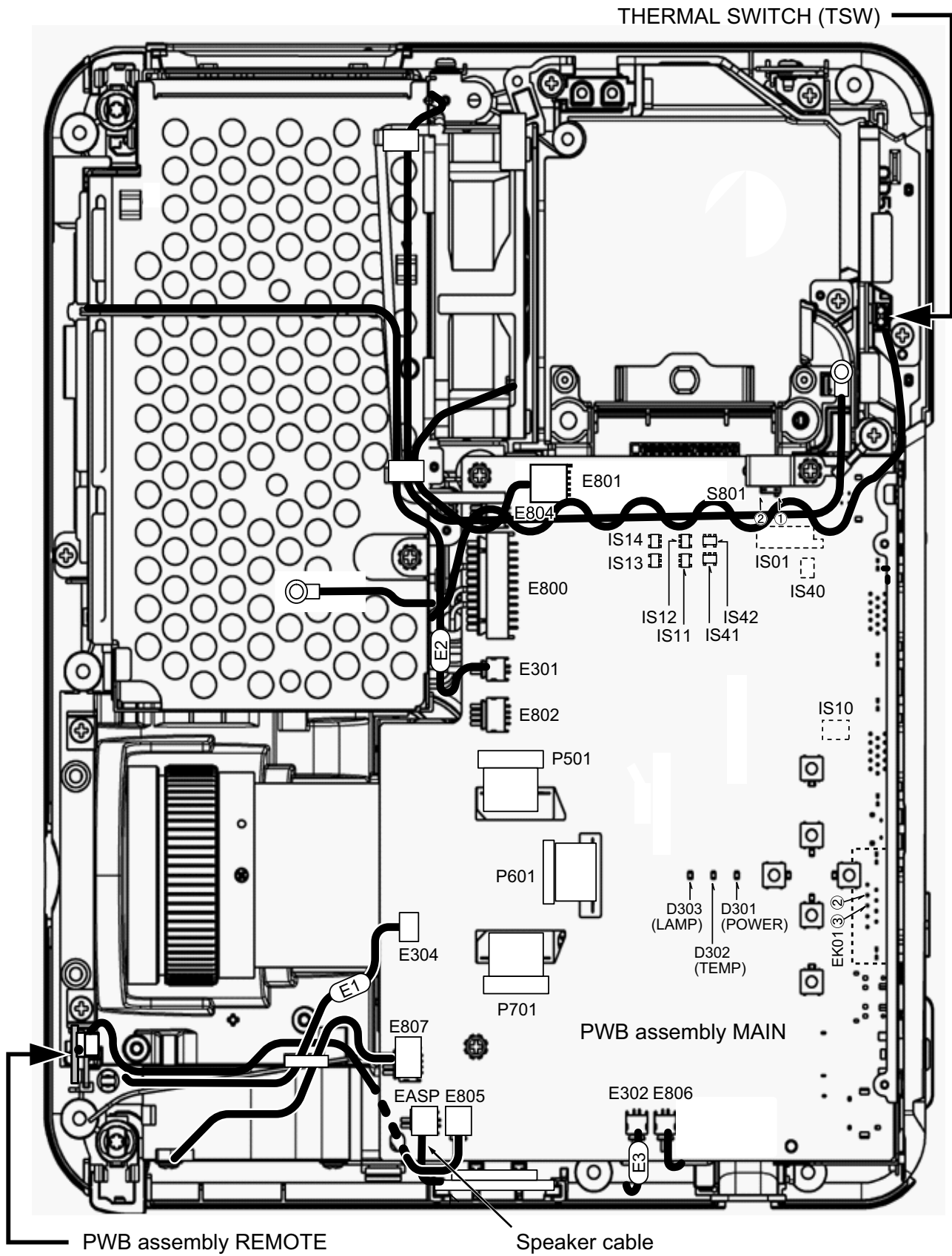

CP-S240(CC9SM)/CP-X250(CC9XM)

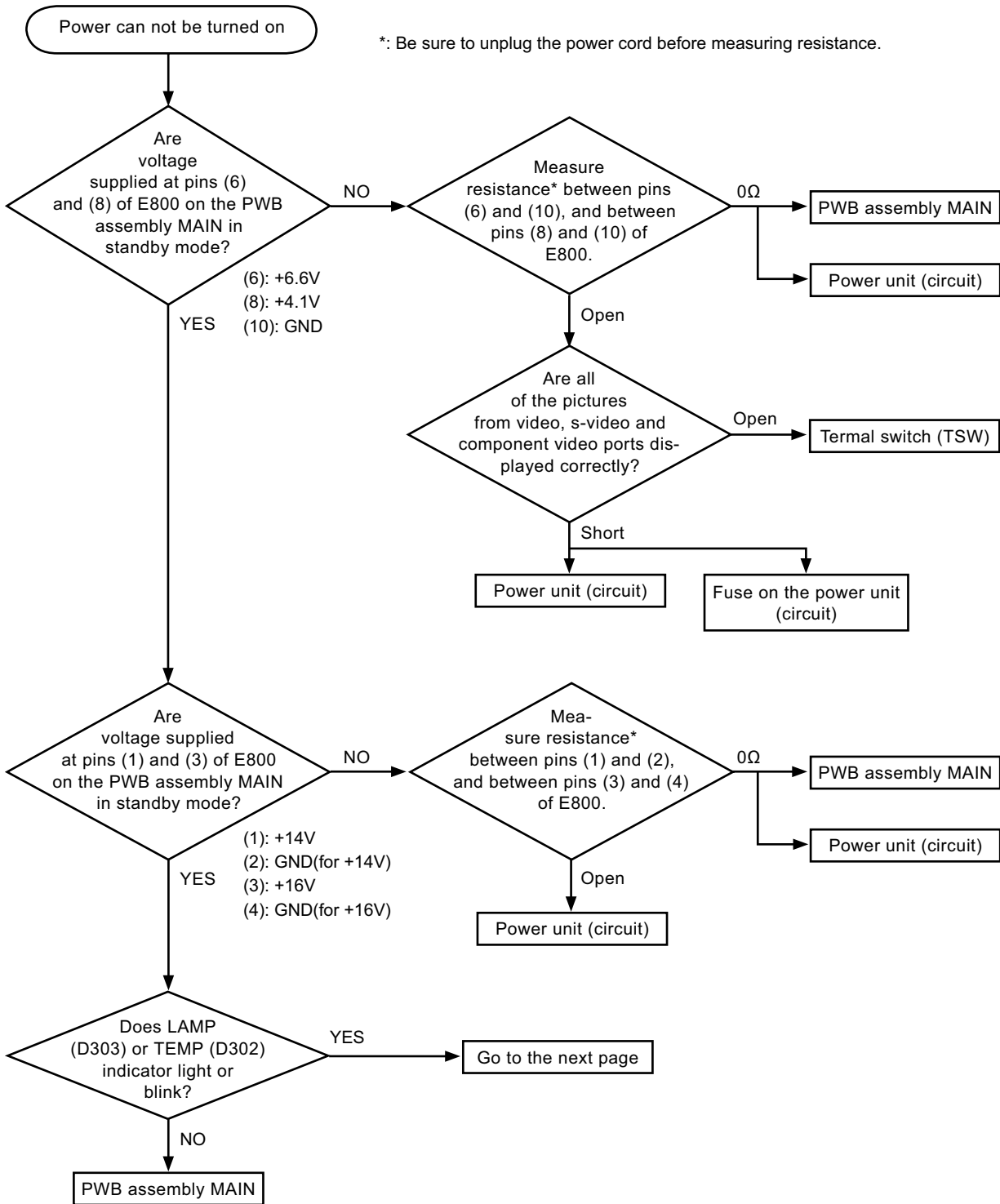

CP-S240(CC9SM)/CP-X250(CC9XM)

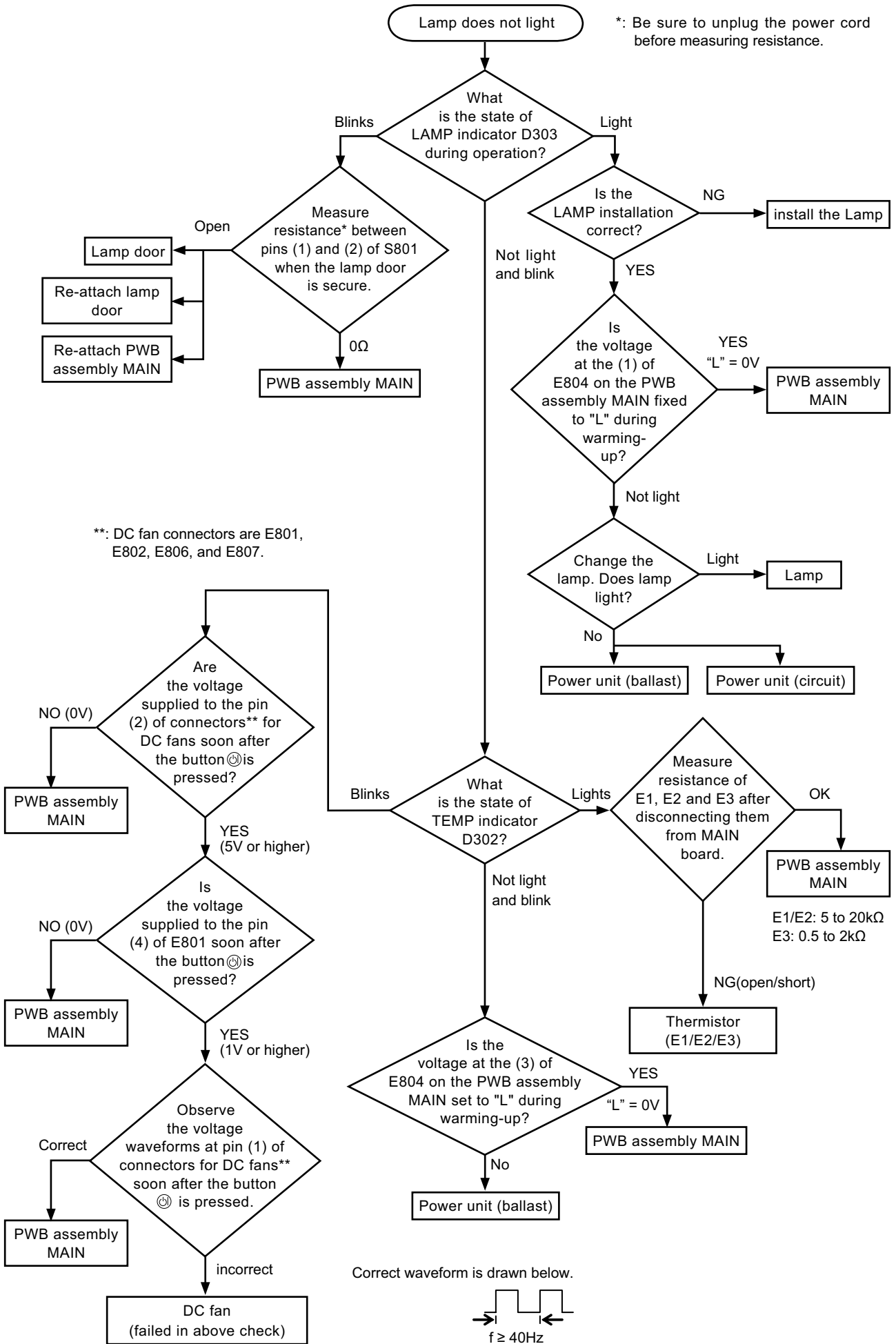

CP-S240(CC9SM)/CP-X250(CC9XM)

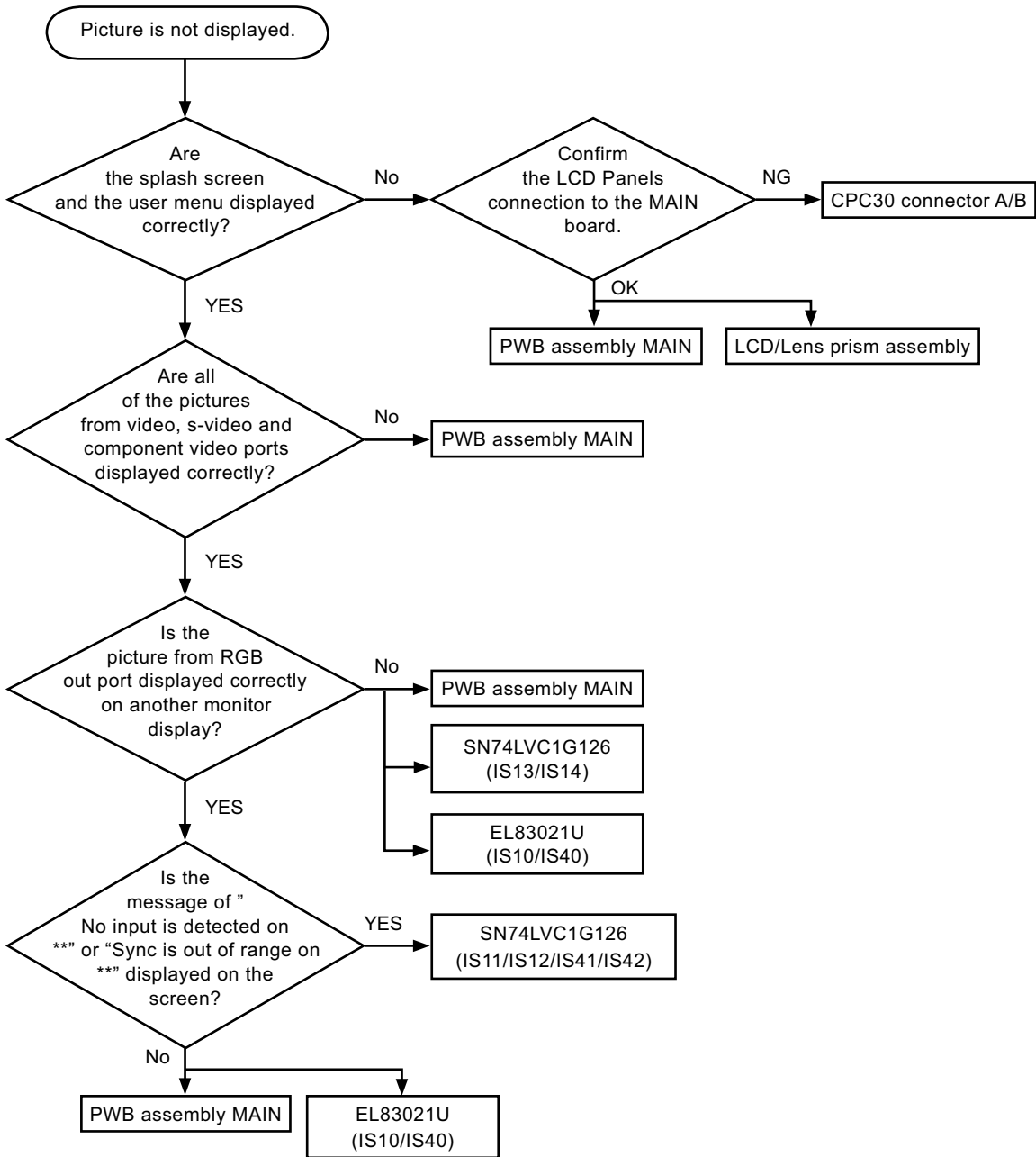

CP-S240(CC9SM)/CP-X250(CC9XM)

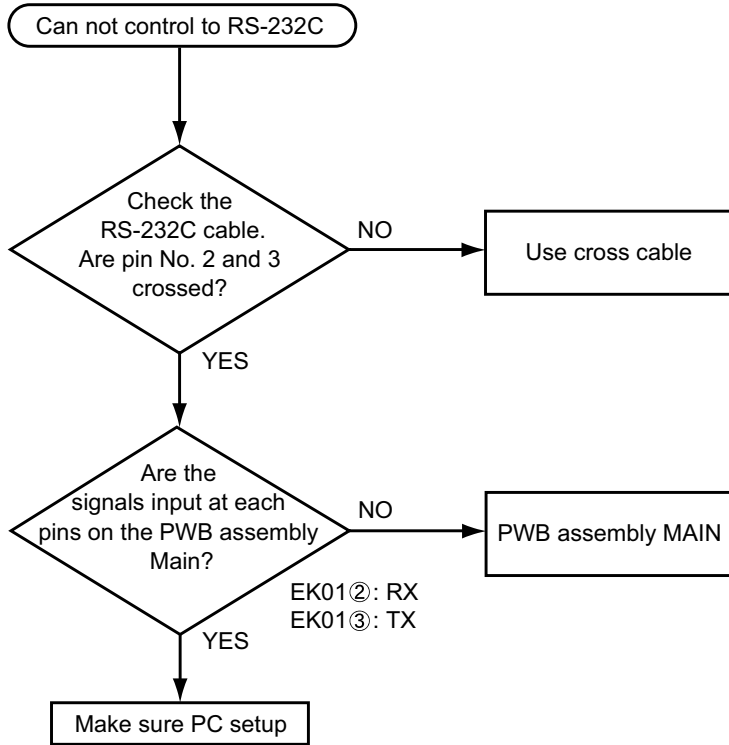
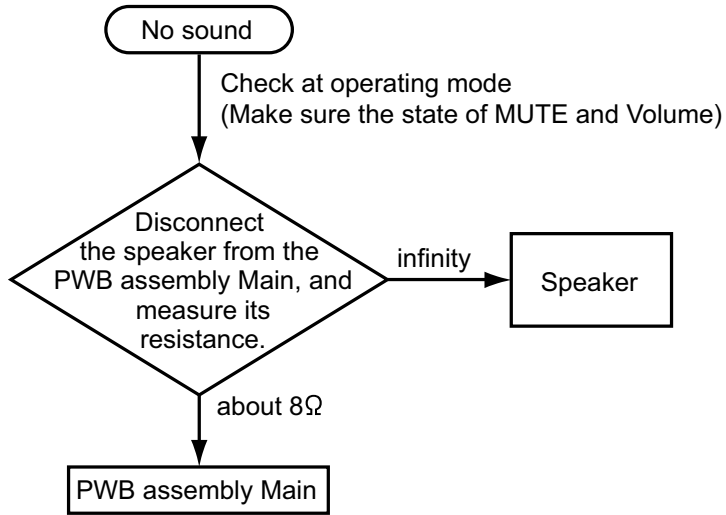

The check after parts change

1. PC power supply OFF
 2. Connection of cable
 3. Projector starting
 4. PC starting
- *When not operating :
PC set up change of cable.

6. Service points

6-1 Lead free solder [CAUTION]

This product uses lead free solder (unleaded) to help preserve the environment. Please read these instructions before attempting any soldering work.

⚠ CAUTION

Always wear safety glasses to prevent fumes or molten solder from getting into the eyes. Lead free solder can splatter at high temperatures (600°C).

■ Lead free solder indicator

Printed circuit boards using lead free solder are engraved with an "F" or "LF".

■ Properties of lead free solder

The melting point of lead free solder is 40-50°C higher than leaded solder.

■ Servicing solder

Solder with an alloy composition of Sn-3.0Ag-0.5Cu or Sn-0.7Cu is recommended.

Although servicing with leaded solder is possible, there are a few precautions that have to be taken. (Not taking these precautions may cause the solder to not harden properly, and lead to consequent malfunctions.)

Precautions when using leaded solder

- Remove all lead free solder from soldered joints when replacing components.
- If leaded solder should be added to existing lead free joints, mix in the leaded solder thoroughly after the lead free solder has been completely melted (do not apply the soldering iron without solder).

■ Servicing soldering iron

A soldering iron with a temperature setting capability (temperature control function) is recommended.

The melting point of lead free solder is higher than leaded solder. Use a soldering iron that maintains a high stable temperature (large heat capacity), and that allows temperature adjustment according to the part being serviced, to avoid poor servicing performance.

Recommended soldering iron:

- Soldering iron with temperature control function (temperature range: 320-450°C)

Recommended temperature range per part:

Part	Soldering iron temperature
Mounting (chips) on mounted PCB	320°C±30°C
Mounting (chips) on empty PCB	380°C±30°C
Chassis, metallic shield, etc.	420°C±30°C

The PWB assembly which has used lead free solder

- | | |
|-------------------------|--------------------------|
| (1) PWB assembly MAIN | (3) POWER UNIT (BALLAST) |
| (2) PWB assembly REMOTE | (4) POWER UNIT (CIRCUIT) |

6-2 Before Replacing The LCD/Lens Prism

You should not replace separately the parts of the liquid crystal LCD/Lens prism because it works properly only when used together. Therefore, regarding these parts, you can either replace part, LCD/Lens prism assembly, or send the whole unit LCD/Lens prism assembly back to HITACHI, where we will replace the malfunctioning part, recondition the device and send it back to you.

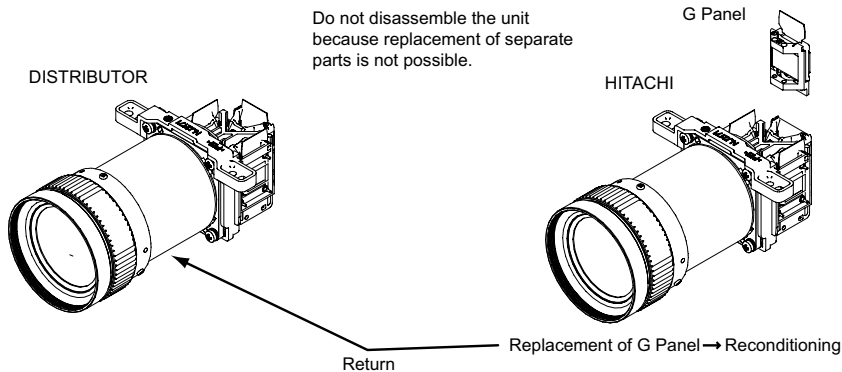

6-3 Cleaning up dust from panels and optical filters

⚠ WARNING

Wear sunglasses to protect your eyes when you maintain the projector with its lamp on.

1. Preparation

Please prepare cleaning tools and materials as follows and prepare relatively clean room so as not to work in additional dust, while carrying out removal operation.

- (1) Swab for cleaning : P#: NX08061, "Cotton stick L147"
- (2) Air duster (Dust blower, spray can)
- (3) Vacuum cleaner

2. Disassemble and setting up.

- (1) Turn off the projector, and unplug the power cord.
- (2) Remove the lamp cover and upper case, according to the disassembling diagram of chapter 8.
- (3) Unscrew the shield sheet and disconnect the LCD panel flexible cables.
- (4) Unscrew PWB assembly MAIN to make it free.

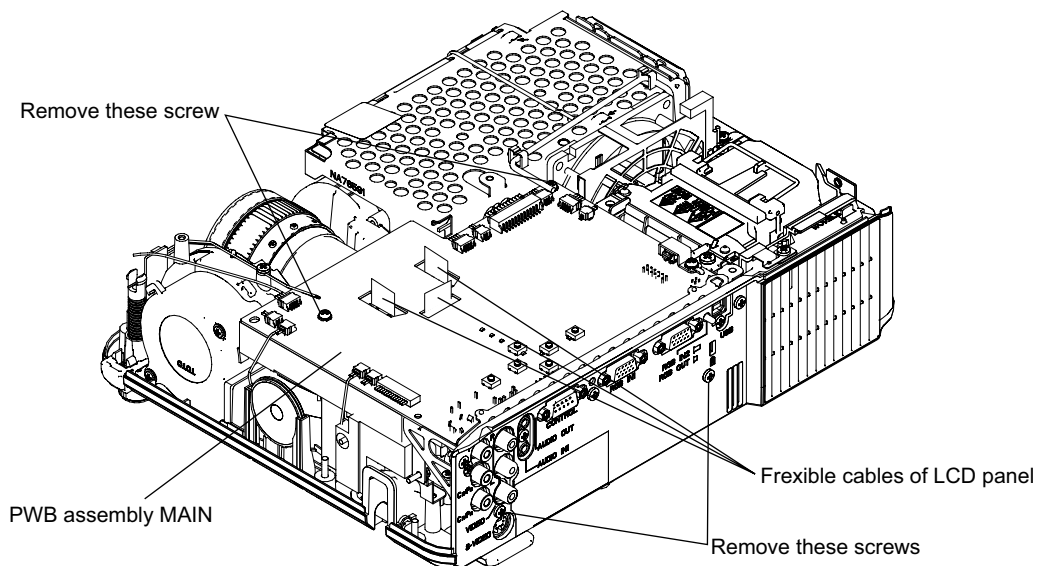

- (5) Press and hold the switch S801 using an insulator during maintenance.
- (6) Keep the unscrewed wires away from all of electric parts.

3. Maintenance point

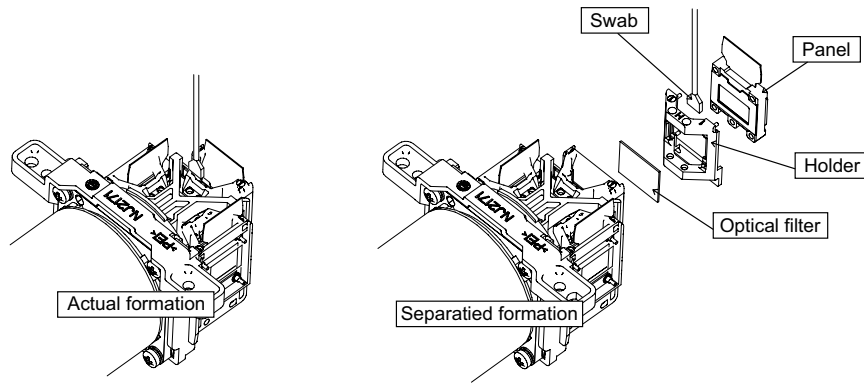

Each color part has same construction.

By using swab and air duster, you can easily remove dust from panel and optical filter.

4. Cleaning the panels and optical filters

- (1) Turn on the set and lit on the lamp.
- (2) By using swab and air duster, remove the dust. Focusing, make sure you check for dust on screen.

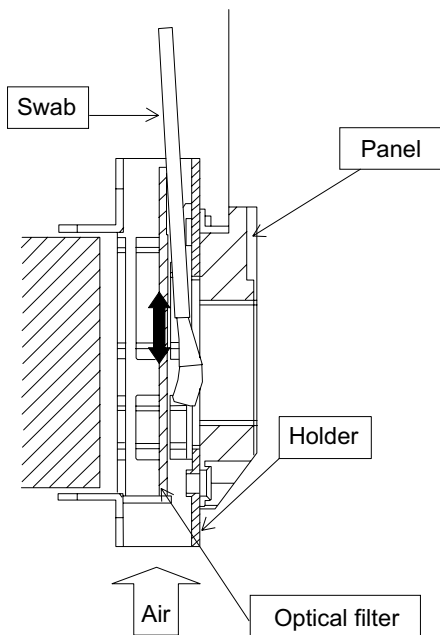

- While removing the dust, separated dust will be blown off by air cooling system.
- Please pay attention not to damage panels and optical filters.

5. Re-assembly

- (1) Turn off the set and unplug the power cord.
- (2) Remove an insulator from S801.
- (3) Screw down the PWB assembly MAIN and connect the LCD panel flexible cables to the PWB assembly MAIN.
- (4) Re-assemble the set.
- (5) While re-assembling, please clean the intake filter and the filter cover by using a vacuum cleaner.

6-4 Putting batteries

WARNING

Always handle the batteries with care and use them only as directed. Improper use may result in battery explosion, cracking or leakage, which could result in fire, injury and/or pollution of the surrounding environment.

- Be sure to use only the batteries specified. Do not use batteries of different types at the same time. Do not mix a new battery with used one.
- Make sure the plus and minus terminals are correctly aligned when loading a battery.
- Keep a battery away from children and pets.
- Do not recharge, short circuit, solder or disassemble a battery.
- Do not allow a battery in a fire or water. Keep batteries in a dark, cool and dry place.
- If you observe a leakage of a battery, wipe out the flow and then replace a battery. If the flow adheres your body or clothes, rinse well with water immediately.

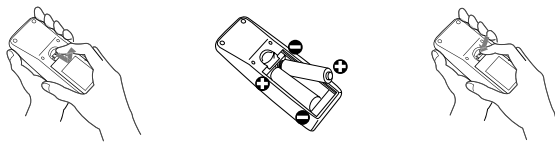

1. Remove the battery cover.
Slide back and remove the battery cover in the direction of the arrow.
2. Insert the batteries.
Align and insert the two AA batteries according to their plus and minus terminals as indicated in the remote control.
3. Close the battery cover.
Replace the battery cover in the direction of the arrow and snap it back into place.

6-5 Air filter

⚠ WARNING

- Before caring, make sure the power switch is off and the power cable is not plugged in, then allow the projector to cool sufficiently. The care in a high temperature state of the projector could cause an electric shock, a burn and/or malfunction to the projector.
- Use only the air filter of the specified type. Do not use the projector with the air filter and the filter cover removed. It could result in a fire and/or malfunction to the projector.
- The air filter should be cleaned periodically. If the air filter becomes clogged by dust or the like, internal temperatures rise and could cause a fire, a burn and/or malfunction to the projector.

NOTE

- Please replace the air filter when it is damaged or too soiled, and also when you replace the lamp.
- Please reset the filter time only when you have cleaned or replaced the air filter, for a suitable indication about the air filter.
- The projector may display the message such as “CHECK THE AIR FLOW” or turn itself off, to prevent the internal heat level rising.

If the air filter becomes clogged by dust or the like, internal temperatures rise and could cause a fire, a burn and/or malfunction to the projector. When the indicators or a message prompts to clean the air filter, clean the air filter as soon as possible.

Please check and clean the air filter periodically, even if there is no message. Please replace the air filter when it is damaged or too soiled.

And also when you replace the lamp, please replace the air filter. An air filter of specified type will come together with a replacement lamp for this projector.

1. Turn the projector off, and unplug the power cord. Allow the lamp to cool for at least 45 minutes.
2. When the projector is suspended from the ceiling, apply the vacuum cleaner to and around the filter cover first, to prevent penetration of dust or the like.
3. While supporting the projector with one hand, use your other hand to pull the filter cover forward in the direction of the arrow. Remove the air filter.
4. Apply a vacuum cleaner to the air filter and the filter cover. Please replace the air filter when it is damaged or too soiled.
5. Replace the air filter in its original position. Secure the air filter in place by pressing each of the six ◁ locations.

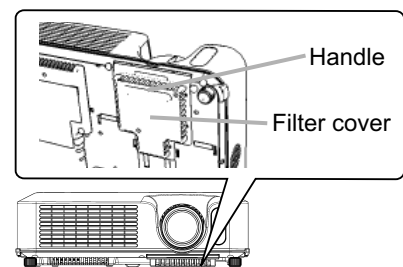

Make sure there is no dust or dirt remaining after the cover is in place.

If any dust or dirt remains, use a vacuum cleaner to remove it as when placing the filter cover on the air filter.

Reattach the filter cover to the projector by aligning the filter cover with the grooves on the projector. While holding the handle, push down on the filter cover until it locks firmly in place.

6. Turn the projector on and reset the filter time using the FILTER TIME function.

(1) Press the MENU button to display a menu. When the EASY MENU has appeared, please skip the next step (2).





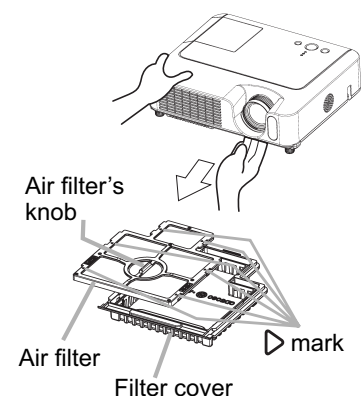

(2) Point at the “OPTION” in the left column of the menu using ▼/▲ button, then press the ► button.

(3) Point at the “FILTER TIME” using ▼/▲ button, then press the ► button. A dialog will appear.

(4) Press the ▲ button to select “RESET” on the dialog. It performs resetting the filter time.



6-6 Lamp

 WARNING		 HIGH VOLTAGE	 HIGH TEMPERATURE	 HIGH PRESSURE
<p>• The projector uses a high-pressure mercury glass lamp. The lamp can break with a loud bang, or burn out, if jolted or scratched, handled while hot, or worn over time. Note that each lamp has a different life-time, and some may burst or burn out soon after you start using them. In addition, when the bulb bursts, it is possible for shards of glass to fly into the lamp housing, and for gas containing mercury to escape from the projector's vent holes.</p>				
<p>• About disposal of a lamp • This product contains a mercury lamp; do not put it in the trash. Dispose of in accord with environmental laws. For lamp recycling, go to www.lamprecycle.org. (in the US) For product disposal, contact your local government agency or www.eiae.org (in the US) or www.epsc.ca (in Canada).</p>				
 <p>Disconnect the plug from the power outlet</p>	<ul style="list-style-type: none"> • If the lamp should break (it will make a loud bang when it does), unplug the power cord from the outlet. Note that shards of glass could damage the projector's internals, or cause injury during handling. • If the lamp should break (it will make a loud bang when it does), ventilate the room well, and make sure not to breathe the gas that comes out of the projector vents, or get it in your eyes or mouth. • Before replacing the lamp, turn the projector off and unplug the power cord, then wait at least 45 minutes for the lamp to cool sufficiently. Handling the lamp while hot can cause burns, as well as damaging the lamp. 			
	<ul style="list-style-type: none"> • Never unscrew except the appointed (marked by an arrow) screws. • Do not open the lamp cover while the projector is suspended from above. This is dangerous, since if the lamp's bulb has broken, the shards will fall out when the cover is opened. • Do not use the projector with the lamp cover removed. At the lamp replacing, make sure that the screws are screwed in firmly. Loose screws could result in damage or injury. 			
	<ul style="list-style-type: none"> • Use only the lamp of the specified type. • If the lamp breaks soon after the first time it is used, it is possible that there are electrical problems elsewhere besides the lamp. If this happens, contact your local dealer or a service representative. • Handle with care: jolting or scratching could cause the lamp bulb to burst during use. • Using the lamp for long periods of time could cause it dark, not to light up or to burst. When the pictures appear dark, or when the color tone is poor, please replace the lamp as soon as possible. Do not use old (used) lamps; this is a cause of breakage. 			

● Replacing the Lamp

A lamp has a finite product life. Using the lamp for long periods of time could cause the pictures darker or the color tone poor. Note that each lamp has a different lifetime, and some may burst or burn out soon after being started using.

1. Turn the projector off, and unplug the power cord. Allow the lamp to cool for at least 45 minutes.
2. Prepare a new lamp.
3. Loosen the lamp cover screw (marked by arrow) and then slide the lamp cover to the side to remove it.
4. Loosen the 2 screws (marked by arrow) of the lamp, and slowly pick up the lamp by the handles.
5. Insert the new lamp, and retighten firmly the two screws that are loosened in the previous process to lock it in place.
6. Slide the lamp cover back in place and firmly fasten the lamp cover screw.
7. Turn the projector on and reset the lamp time using the LAMP TIME function in the OPTION menu.

- (1) Press the MENU button to display a menu. Only when the EASY MENU has appeared, please perform the next step (2).
- (2) Point at the "Go To Advance Menu ..." in the menu using ▼/▲ button, then press the ► button.
- (3) Point at the "OPTION" in the left column of the menu using ▼/▲ button, then press the ► button.
- (4) Point at the "LAMP TIME" using ▼/▲ button, then press the ► button. A dialog will appear.
- (5) Press the ▲ button to select "RESET" on the dialog. It performs resetting the lamp time.

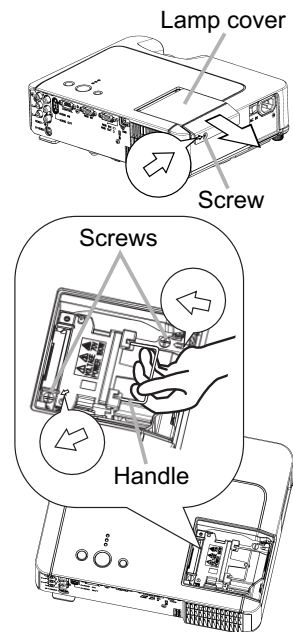

NOTE

- Please reset the lamp time only when you have replaced the lamp, for a suitable indication about the lamp.

6-7 Other care

WARNING

Before caring, make sure the power switch is off and the power cable is not plugged in and then allow the projector to cool sufficiently. The care in a high temperature state of the projector could cause a burn and/or malfunction to the projector.

Avoid wetting the projector or inserting liquids in the projector. It could result in a fire, an electric shock and/or malfunction to the projector.

- Don't put a container containing water, cleaner or chemicals near the projector.
- Don't use aerosols or sprays.

CAUTION

Please take right care of the projector according to the following. Incorrect care could cause not only an injury but adverse influence such as discoloration, peeling paint, etc.

- Do not use cleaner or chemicals other than those listed below.
- Do not polish or wipe with hard objects.

● **Inside of the projector**

In order to ensure the safe use of the projector, it needs to be cleaned and inspected about once a year.

● **Caring for the lens**

If the lens is flawed, soiled or fogged, it could cause deterioration of display quality. Please take care of the lens, being cautions of the handling.

1. Turn the projector off and unplug the power cord. Allow the projector to cool sufficiently.
2. After making sure that the projector is cooled adequately, lightly wipe the lens with a commercially available lens-cleaning wipe. Do not touch the lens directly with your hand.

● **Caring for the cabinet and remote control**

Incorrect care could have adverse influence such as discoloration, peeling paint, etc.

1. Turn the projector off and unplug the power cord. Allow the projector to cool sufficiently.
2. After making sure that the projector has cooled adequately, lightly wipe with gauze or a soft cloth.
If soiling is severe, dip soft cloth in water or a neutral cleaner diluted in water and wipe lightly after wringing well. Then, wipe lightly with a soft, dry cloth.

6-8 Notice of AUTO adjustment

Use of AUTO adjustment with the image through RGB input optimizes V_POSI, H_POSI, H_SIZE and H_PHASE automatically.

In case that projected image has dark tone around its peripheral, AUTO operation sometimes makes artifacts in the image, shifts capture area and so on. Those failures are caused by period of image data is not exactly distinguished to period of blanking on signal processing.

To avoid such phenomena, AUTO function should be used with the full size picture that has bright tone on its peripheral.

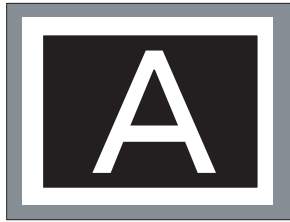

Image when AUTO operates correctly



Image when AUTO fails.

- Noting image of top or bottom lines.
- Shift of the image to East or West.
- Artifacts on image. Etc.

Note

- 1) The phenomenon at the failure of AUTO adjustment depends on resolution of input source, scene of picture etc.
- 2) There is no failure above in AUTO with video source through VIDEO, S-VIDEO or COMPONENT input. The reason is why recognition of input signal's standard does not need to search the capture range from input signal itself.

6-9 PIN LOCK System

If the following PIN BOX menu appears after power on the projector, the PIN LOCK system has been activated. Under such a condition, key operations and signal displaying are inhibited. To open the PIN LOCK system, we need to input the correct 4 digits PIN CODE. If correct PIN CODE is not input in 5 min., the lamp will be automatically turned off.

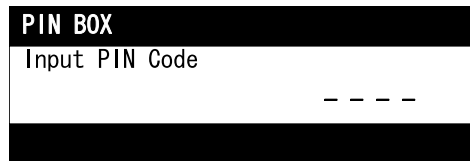

PIN BOX

Returning repaired unit

Use the Master PIN code. See the paragraph of Releasing the PIN LOCK system inactivation.

Swap unit/Returned unit

Inactivate the PIN LOCK system. See the paragraph of the PIN LOCK system inactivation.

Releasing the PIN LOCK System

When the PIN BOX menu is displayed, sequentially enter the codes with remote controller as follows. In accordance with remote controller button entry, "*" mark appears in the PIN BOX menu.

Master PIN codes

1st entry code: Press the "MENU" button.

2nd entry code: Press the "▼" button.

3rd entry code: Press the "KEYSTONE" button.

4th entry code: Press the "▲" button.

Note: The Master PIN codes can be used up to 30 times. The codes cannot be used thereafter. If the Master PIN codes cannot be used, see the paragraph of the PIN LOCK system inactivation.

The PIN LOCK System inactivation

1. When the PIN BOX menu is displayed, press "RESET" for 3 seconds or more in order to get the ID Inquiring Code.

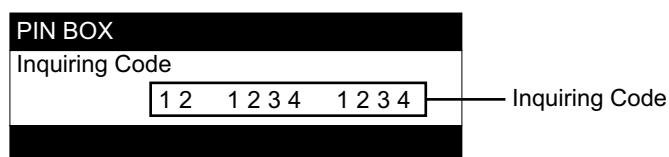

PIN BOX (ID Inquiring Code)

2. Send HITACHI sales company the Inquiring code (10 digits) to inquire the correct PIN code.

3. With the PIN BOX menu displayed, input the correct PIN code. Enter the correct PIN CODE that HITACHI sales company informed.

4. Open menu and select "TURN OFF" from the PIN LOCK items in the OPTION menu. Then the PIN BOX menu appears.

5. Input the correct PIN code in the PIN BOX menu.

6. And then, the OPTION menu appears.

After the PIN LOCK system is inactivated, the PIN BOX is no longer displayed in the OPTION menu.

If the PIN LOCK items are kept displaying, the PIN LOCK system is not inactivated yet. Input the correct PIN CODE again.

6-10 MyScreen PIN LOCK

MyScreen PIN LOCK is a function to disable capturing and storing a picture for MyScreen by using the PIN. Follow the procedure below to use this function.

How to activate MyScreen PIN LOCK

1. Open the user menu and go to the advance menu.
2. Go down to "SCREEN" and go right and select "MyScreen LOCK".
3. Go right and get the following dialog. Press the ► button one time and keep pressing the ► button in 2nd time (for about 3sec. or more).

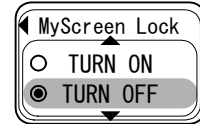

4. The following window comes up. Enter your PIN.

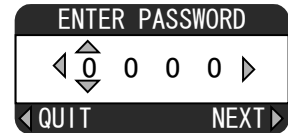

5. Re-enter your PIN correctly, and press the ► button.

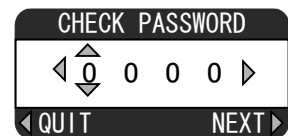

6. You will see your PIN for confirmation for a while.

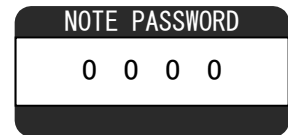

7. PIN lock is activated.

How to inactivate the MyScreen PIN LOCK

To inactivate the PIN lock, go to "MyScreen PIN LOCK" and select "Turn OFF". After the following dialog appears, enter the PIN. If you forget the PIN, you need to tell the Inquiring code to HITACHI to decode the PIN.

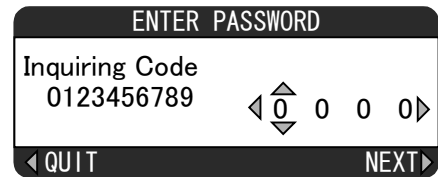

6-11 Related Messages

When the unit's power is on, messages such as those shown below may be displayed. When any such message is displayed on the screen, please respond as described below.

Although these messages will be automatically disappeared around several minutes, it will be reappeared every time the power is turned on.

Message	Description
NO INPUT IS DETECTED ON ***	There is no input signal. Please confirm the signal input connection, and the status of the signal source.
SYNC IS OUT OF RANGE ON *** [H] *****kHz [V] *****Hz	The horizontal or vertical wavelength of the inputted signal is outside of the response parameters of this unit. Please confirm the specs for this unit or the signal source specs.
CHECK THE AIR FLOW	The internal portion temperature is rising. Please turn the power OFF, and allow the unit to cool down at least 20 minutes. After having confirmed the following items, please turn the power ON again. <ul style="list-style-type: none"> • Is there blockage of the air passage aperture? • Is the air filter dirty? • Does the peripheral temperature exceed 35°C? • If the same indication is after the treatment, please set the HIGH at FAN SPEED of the item SERVICE of the OPTION menu.
REMINDER ***HRS PASSED AFTER THE LAST FILTER CHECK. FILTER MAINTENANCE IS ESSENTIAL TO REMOVE WARNING MESSAGE, RESET FILTER TIMER. SEE MANUAL FURTHER INFO.	A note of precaution when cleaning the air filter. Please immediately turn the power OFF, and clean or change the air filter by referring to the "Air Filter" section of this manual. After you have cleaned or changed the air filter, please be sure to reset the filter timer.

6-12 Regarding the indicator lamps

Lighting and flashing of the POWER indicator, the LAMP indicator, and the TEMP indicator have the meanings as described in the table below. Please respond in accordance with the instructions within the table.

POWER indicator	LAMP indicator	TEMP indicator	Description
Lighting In Orange	Turned off	Turned off	The projector is in a standby state.
Blinking In Green	Turned off	Turned off	The projector is warming up. Please wait.
Lighting In Green	Turned off	Turned off	The projector is in an on state. Ordinary operations may be performed.
Blinking In Orange	Turned off	Turned off	The projector is cooling down. Please wait.
Blinking In Red	(discretionary)	(discretionary)	The projector is cooling down. A certain error has been detected. Please wait until the POWER indicator finishes blinking, and then perform the proper measure using the item descriptions below.
Blinking In Red or Lighting In Red	Lighting In Red	Turned off	The lamp does not light, and there is a possibility that interior portion has become heated. Please turn the power off, and allow the projector to cool down at least 20 minutes. After the projector has sufficiently cooled down, please make confirmation of the following items, and then turn the power on again. <ul style="list-style-type: none"> • Is there blockage of the air passage aperture? • Is the air filter dirty? • Does the peripheral temperature exceed 35°C? If the same indication is displayed after the remedy, please change the lamp referring to the section "Lamp".
Blinking In Red or Lighting In Red	Blinking In Red	Turned off	The lamp cover has not been properly fixed (attached). Please turn the power off, and allow the unit to cool down at least 45 minutes. After the projector has sufficiently cooled down, please make confirmation of the attachment state of the lamp cover. After performing any needed maintenance, turn the power on again.
Blinking In Red or Lighting In Red	Turned off	Blinking In Red	The cooling fan is not operating. Please turn the power off, and allow the unit to cool down at least 20 minutes. After the projector has sufficiently cooled down, please make confirmation that no foreign matter has become caught in the fan, etc., and then turn the power on again. If the same indication is displayed after the remedy, please replace a fan.
Blinking In Red or Lighting In Red	Turned off	Lighting In Red	There is a possibility that the interior portion has become heated. Please turn the power off, and allow the unit to cool down at least 20 minutes. After the projector has sufficiently cooled down, please make confirmation of the following items, and then turn the power on again. <ul style="list-style-type: none"> • Is there blockage of the air passage aperture? • Is the air filter dirty? • Does the peripheral temperature exceed 35°C? If the same indication is displayed after the remedy, please set the FAN SPEED of the SERVICE item in the OPTION menu to HIGH.
Lighting In Green	Alternative blinking in Red		There is a possibility that the interior portion has become overcooled. Please use the unit within the usage temperature parameters (5°C to 35°C). After the treatment, reset the power to ON. If the same indication is displayed after the treatment, please make sure that the proper cables are connected to each of connectors E301 and E302 on the PWB assembly MAIN.
Lighting In Green	Simultaneous blinking in Red		It is time to clean the air filter. Please immediately turn the power OFF, and clean or change the air filter referring to the section "Air Filter". After cleaning or change the air filter, please be sure to reset the filter timer. After the remedy, reset the power to ON.

NOTE • When the interior portion has become overheated, for safety purposes, the power source is automatically turned off, and the indicator lamps may also be turned off. In such a case, press the "o" (OFF) side of the power switch, and wait at least 45 minutes. After the projector has sufficiently cooled down, please make confirmation of the attachment state of the lamp and lamp cover, and then turn the power on again.

6-13 HIDDEN SERVICE MENU

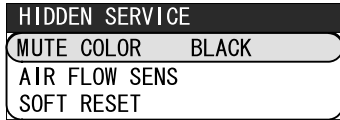

To display the OSD for "HIDDEN SERVICE MENU" set up.

By the control panel	By the remote control transmitter
<ol style="list-style-type: none"> 1. Display the Advance menu by the "MENU" button.(If EASY MENU appears, choose "Go to Advance menu" to display ADVANCE MENU.) 2. Select the "OPTION" on the menu. 3. Continue press the button [◀] first, then press the button [◀] together with "INPUT", and hold for 3 seconds. 	<ol style="list-style-type: none"> 1. Display the menu by the "MENU" button. (If EASY MENU appears, choose "Go to Advance menu" to display ADVANCE MENU.) 2. Select the "OPTION" on the menu. 3. Press the "MAGNIFY OFF" button. Next hold the "MAGNIFY OFF" button for 3 seconds.

● SOFT RESET

If this is executed, all of the user data is initialized.Never use it when not required.

6-14 RUN TIME window

● Set operating time display method (accumulated lamp time display method)

1. Select "OPTION" from the Advance menu, then place the cursor on the "LAMP TIME".
2. Press the [▶], [ENTER] or [RESET] button.
3. Press the [Reset] button once, then press [KEystone] button of the remote control for 3 seconds or more to display the screen shown below. (The menu will close after 10 seconds if there are no further operations.)
4. Use [▲] or [▼] to select the usage status number. (The usage status is as shown below.)

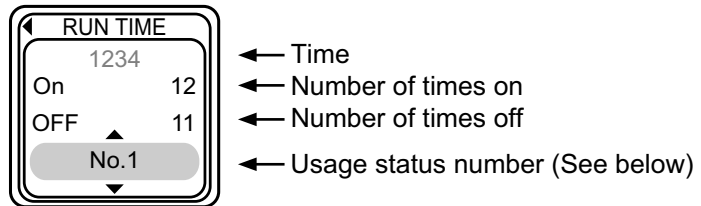

Usage status number

- 0 Total usage status
- 1 Current usage status
- 2 Usage status before first reset
- 3 Usage status before second reset
- ||
- 9 Usage status before eighth reset
- 10..... Total time(hrs.) the projector has been used in both stand-by and operation

7. Wiring diagram

Wiring of the circuit power supply (1/2)

Wiring of the circuit power supply main board

- (1) Attach the FB1
- (2) Connect the TSW. Make sure to confirm the seal (based on the diagram below) when attaching the TSW.
- (3) Connect the CNPWR, attach FB2
- (4) Connect the CNPOW, attach FB5

Area of Importance
 The operations with this symbol have implications with laws/standards. It is possible to be in violation of these laws/standards in the case that these operations are not carried out according to the instructions. Assemble according to the operation instructions.

Make sure to securely connect the CNPOW, TSW, and CNPWR to the circuit power supply (as it cannot be confirmed whether they are securely connected in later processes).

Attach the FB1 (ferrite core) to the FG1 wire of the circuit power supply. Make sure to completely lock the hook when attaching the FB1.
Area of Importance
 Secure the FB1 around the center of the FG1 with the cable tie Z1. Cut the cable tie with 2 to 3 mm of excess length remaining.

Attach the FB5 (ferrite core) to CNPOW. Make sure to completely lock the hook when attaching the FB5.
Area of Importance
 It is not necessary to secure the FB5 with a cable tie.

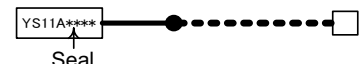
Make sure to confirm the print of the TSW.
Area of Importance

 Seal
 Confirm that the print indicates "YS11A85A - * *"

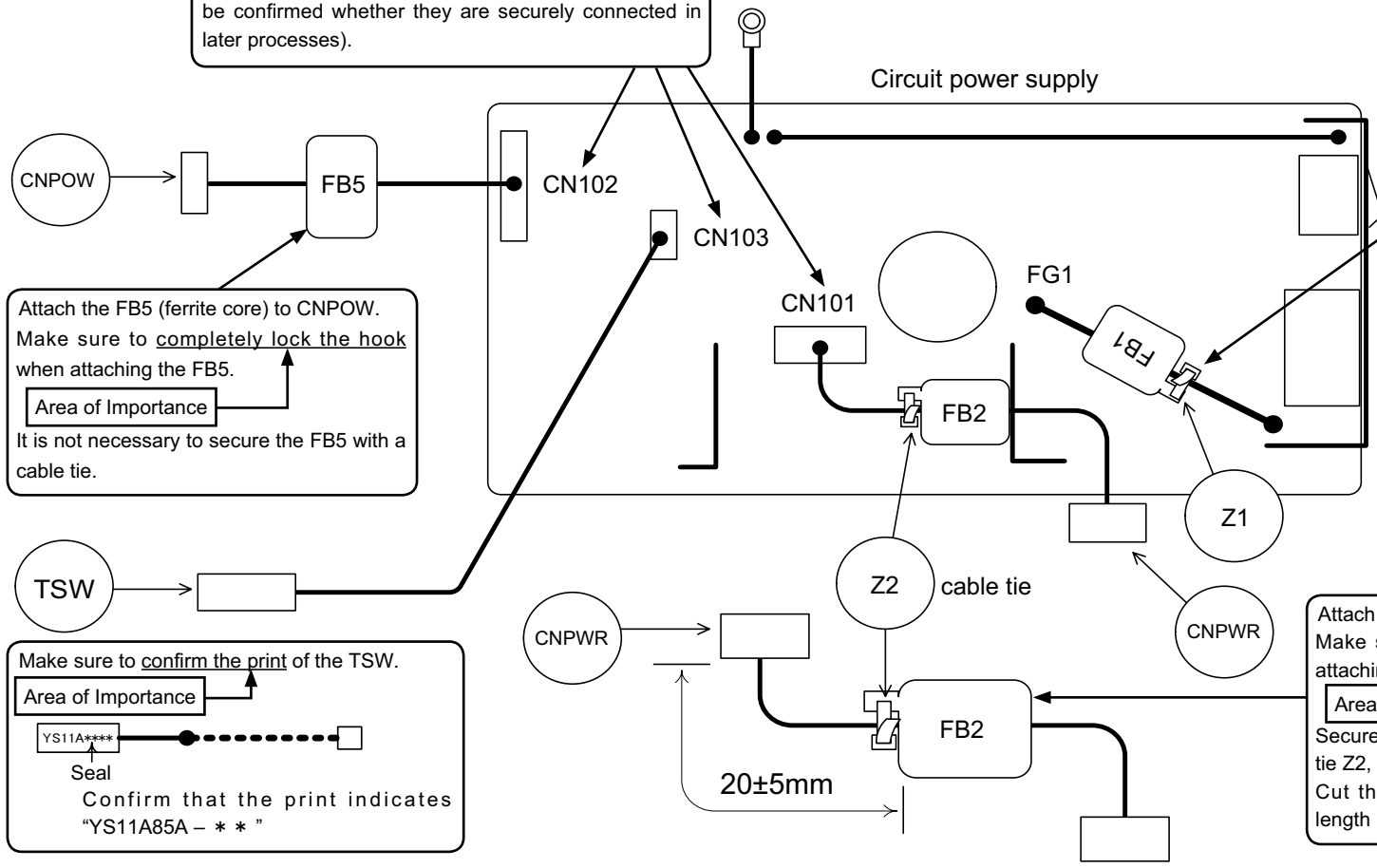
Attach the FB2 (ferrite core) to the CNPWR. Make sure to completely lock the hook when attaching the FB2.
Area of Importance
 Secure the FB2 to the CNPWR with the cable tie Z2, as indicated in the diagram. Cut the cable tie with 2 to 3 mm of excess length remaining.



Wiring diagram 1

Wiring of the circuit power supply (2/2)

Wiring of the circuit power supply board

- (1) Style the CNPOW, TSW, and FG3.
- (2) Attach the CNSH2
- (3) Attach the power supply sheet.
- (4) Style the CNPWR.

Lock the CNPOW, TSW, and FG3 by passing them through the power supply case fastener.

Make sure to pass the CNSH2 through the hole indicated in the diagram below.
[CAUTION]
 Make sure to attach the power supply sheet after attaching the CNSH2.

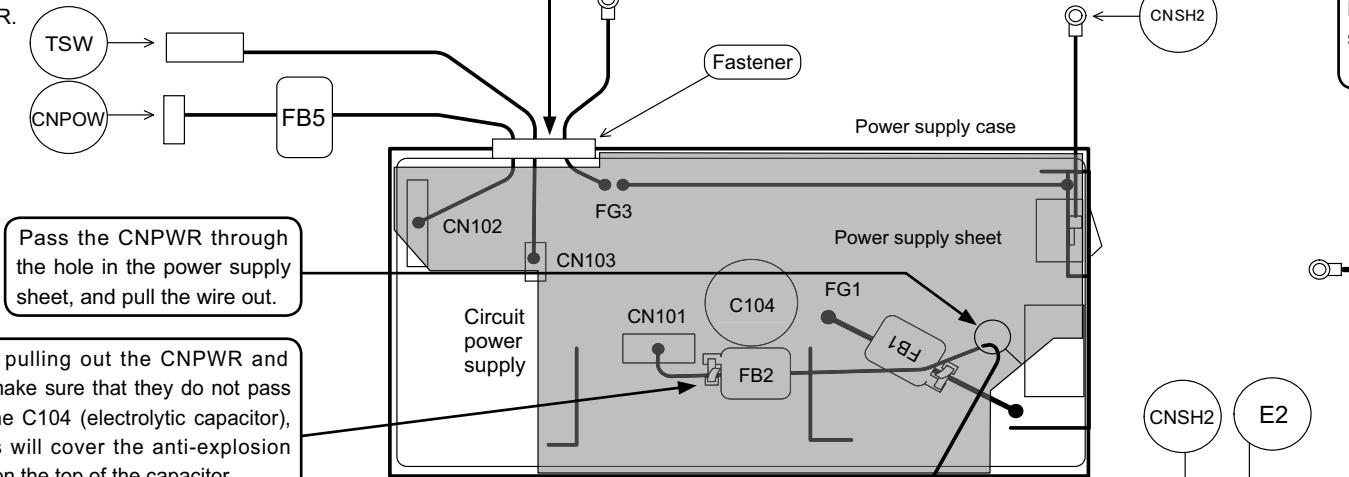

Pass the CNPWR through the hole in the power supply sheet, and pull the wire out.

When pulling out the CNPWR and FB2, make sure that they do not pass over the C104 (electrolytic capacitor), as this will cover the anti-explosion valve on the top of the capacitor.

Fasten the CNSH2 and E2 with tape, ZTP1 and ZTP2, after passing them through the clamps of the power supply case.
[CAUTION]
 As the upper case touches the gray areas of the diagram on the right, make sure no wires protrude into these areas.

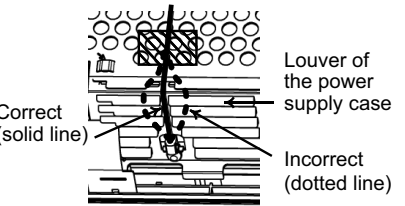
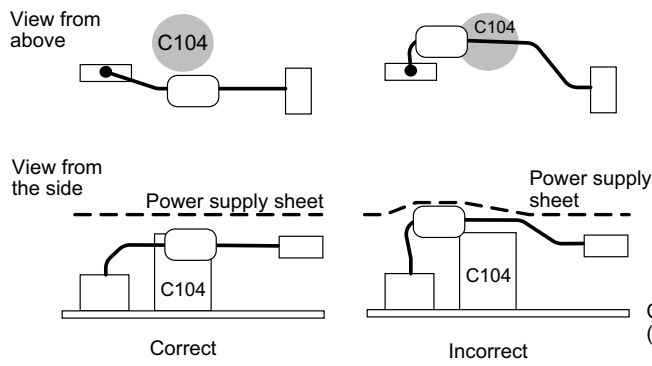

Don't wire the E2 on the louvers.
 The solid line in the diagram indicates an example of correct wiring.
 The dotted lines in the diagram indicate examples of incorrect wiring.

Fasten the E2 with tape ZTP1. Make sure to stick the tape along the outline of the power supply case holes as shown in the diagram.

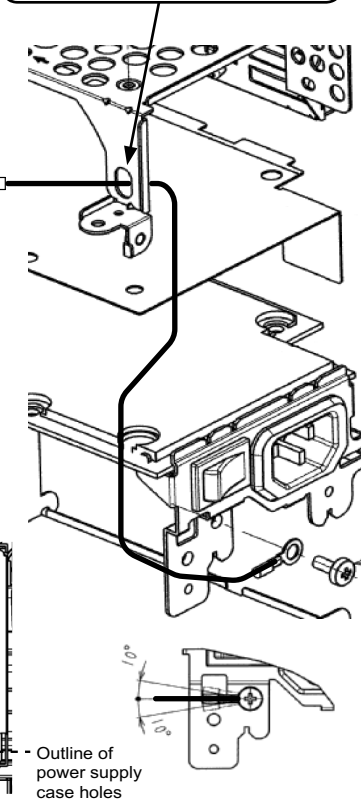

Wiring diagram 2

Wiring of the ballast power supply

Wiring of the ballast power supply board

- (1) Attach and wire the FB3 to the lamp lead
- (2) Attach the FB4, and wire the CNBAR and sirocco fan.

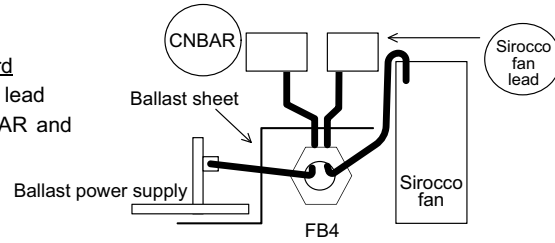

Style the lamp lead of the ballast power supply by passing it through the groove in the bottom case. Make sure the sag in the wires is absorbed in the direction of the arrow.

Pull out the CNBAR, sirocco fan lead, and FB4 from the sheet hole after passing them under the ballast sheet. Make sure the sag in the wires is absorbed in the direction of the arrow.

Attach the FB4 (ferrite core) to the CNBAR and sirocco fan lead. Wind the CNBAR around once. Make sure to completely lock the hook when attaching the FB4.

Area of Importance

It is not necessary to secure the FB4 with a cable tie.

[CAUTION]
Be careful of where you attach the FB4.

If the wire of the CNBAR sags, it will get close to the primary circuit inside the ballast power supply. Therefore, be careful of where you attach the FB4, as it prevents the CNBAR wire from sagging.

Pull out the lamp lead of the ballast power supply by passing it through the slit in the ballast sheet. Style by turning the boss on the bottom case.

Attach the FB3 (ferrite core) to the lamp lead of the ballast power supply. Make sure to completely lock the hook when attaching the FB3.

Area of Importance

It is not necessary to secure the FB3 with a cable tie.

[CAUTION]
Be careful when handling the ballast power supply. Do not hold the small circuit board of the ballast power supply. Make sure to connect the CNBAR before attaching the ballast power supply.

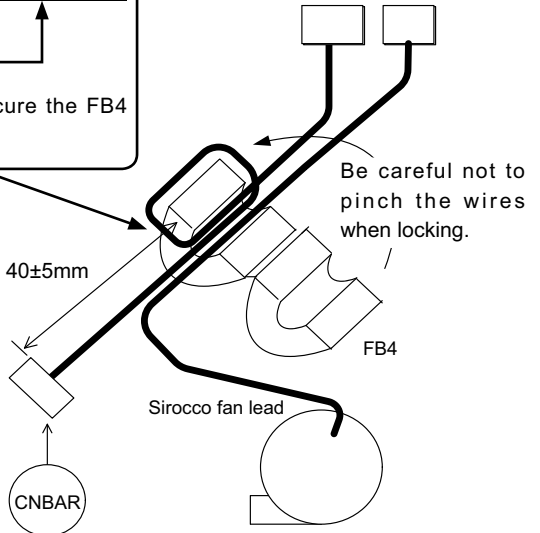

Style the sirocco fan lead by winding it around the top, to prevent the lead escaping the hook. Fasten the fan lead with tape ZTP5 after styling.

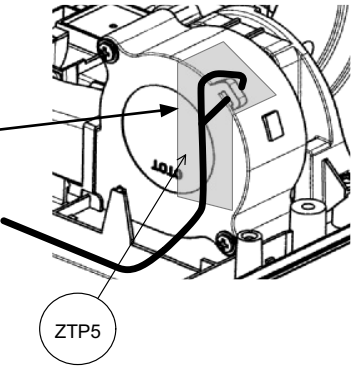

Wiring diagram 3

Wiring of the power supply block

Wiring when assembling the power supply block

- (1) Connect and style the CNPWR
- (2) Wire the CNBAR and sirocco fan lead.
Attach the power supply block.
- (3) Connect and wire the CNSH.
- (4) Wire the lamp sirocco fan lead.

Tighten this screw manually, pressing the power supply case toward the bottom case.

Area of Importance

so that the power supply bracket does not strain.

Connect the CNPWR to the ballast power supply. Make sure it is securely connected. (as it cannot be confirmed whether they are securely connected in later processes).

[CAUTION]
Assemble the power supply block after connecting the CNPWR.

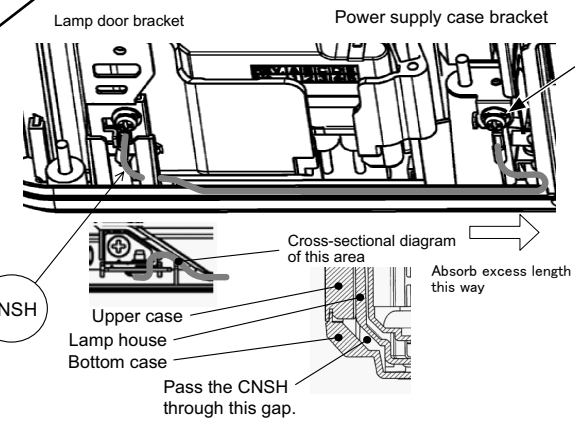
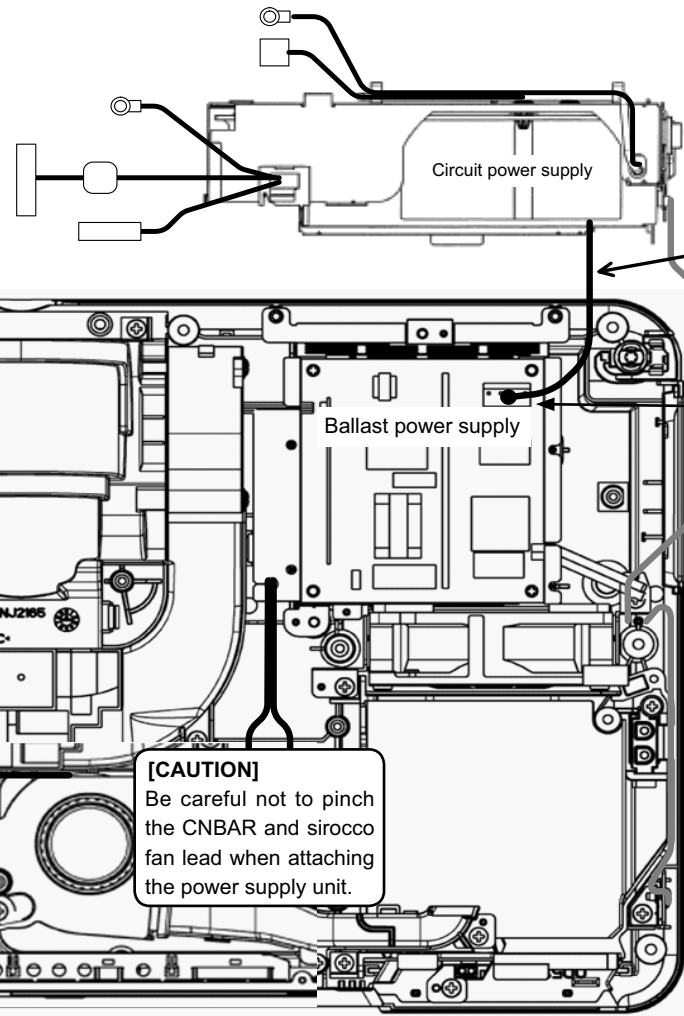

CNSH

Connect the CNSH to the lamp door bracket and power supply case bracket.

Area of Importance

Pass the CNSH through the hole below the lamp door bracket, and style it by passing it through the gap between the bottom case and lamp house. Make sure the excess length of the wires is absorbed in the direction of the arrow.

[CAUTION]
Connect the CNSH to the power supply case side only after assembling the power supply block.

[CAUTION]
Complete the pulling out of the lamp sirocco fan lead before attaching the optical engine.

[CAUTION]
Be careful not to pinch the CNBAR and sirocco fan lead when attaching the power supply unit.

Wiring diagram 4

Wiring when attaching the main board (1/2)

Wiring when attaching the main board

- (1) Prepare the TSW and CNSH2.
- (2) Temporarily style the E2, FG3, exhaust fan, and TSW/CNSH2.
- (3) Connect the CNPOW, CNBAR, and sirocco fan to the main board.
- (4) Attach the main board, and style the connectors.

When attaching the main board, keep the wires of E2, FG3, exhaust fan, and TSW and CNSH2 (which have been prepared) out of the way by placing them on the top of the power supply unit.

Wind the TSW around the CNSH2 5 times.
 Area of Importance
 Fasten the end of the winding area with tape. Keep the prepared TSW and CNSH2 out of the way by placing them on the top of the power supply unit.

① After lifting up the main board, connect the CNPOW, CNBAR, and sirocco fan.

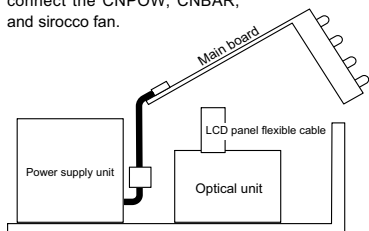

② With the connector connected, insert the terminal side of the main board into the bottom case, and pass the LCD panel flexible cables through the holes in the board.

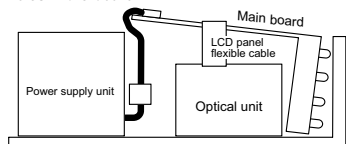

③ Confirm that none of the connector wires are pinched, and attach the main board. Insert the wires and core in the gap between the optical unit and the power supply unit.

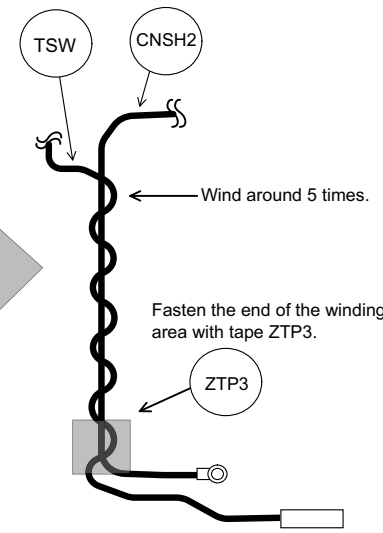
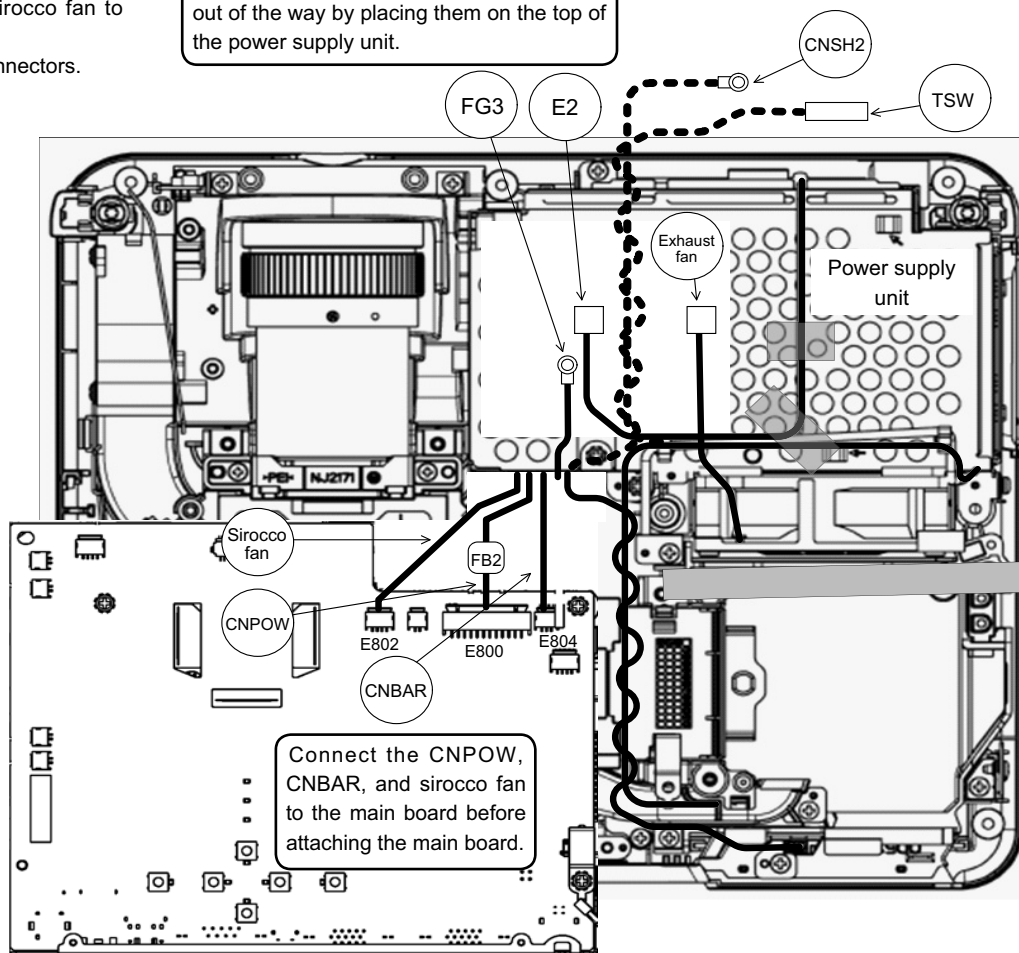
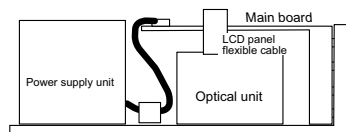

Wiring diagram 5

Wiring when attaching the main board (2/2)

Wiring when attaching the main board

- (1) Connect the LCD panel flexible cables.
- (2) Connect the E2 and exhaust fan.
- (3) Connect the speaker.
- (4) Connect and style the E1 and sirocco fan.
- (5) Attach the remote control board and connect and style the CNRM.
- (6) Connect and style the E3 and lamp sirocco fan.

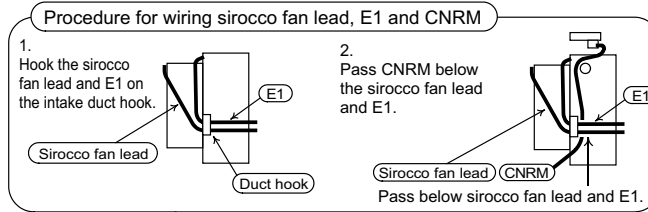

Connect the E2 to the main board after passing it through the clamp of the power supply bracket.

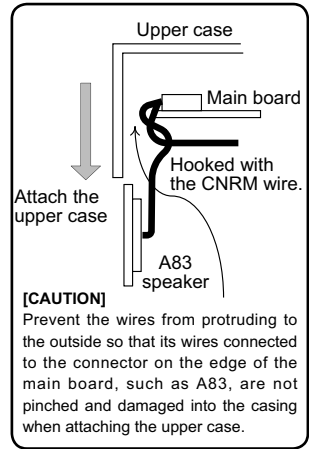

Connect the A83 (speaker) to the main board.

Connect the sirocco fan and E1 to the main board after passing them through the intake duct hook.

Connect the CNRM to the main board from above the A83 (speaker), after passing it below the sirocco fan and E1 wires.

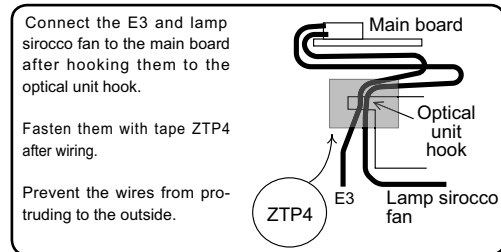

- Sirocco fan
- E1
- Intake duct hook
- CNRM
- A83
- E3
- Lamp sirocco

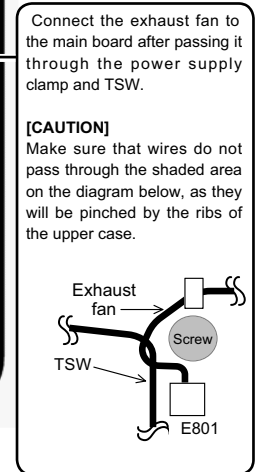
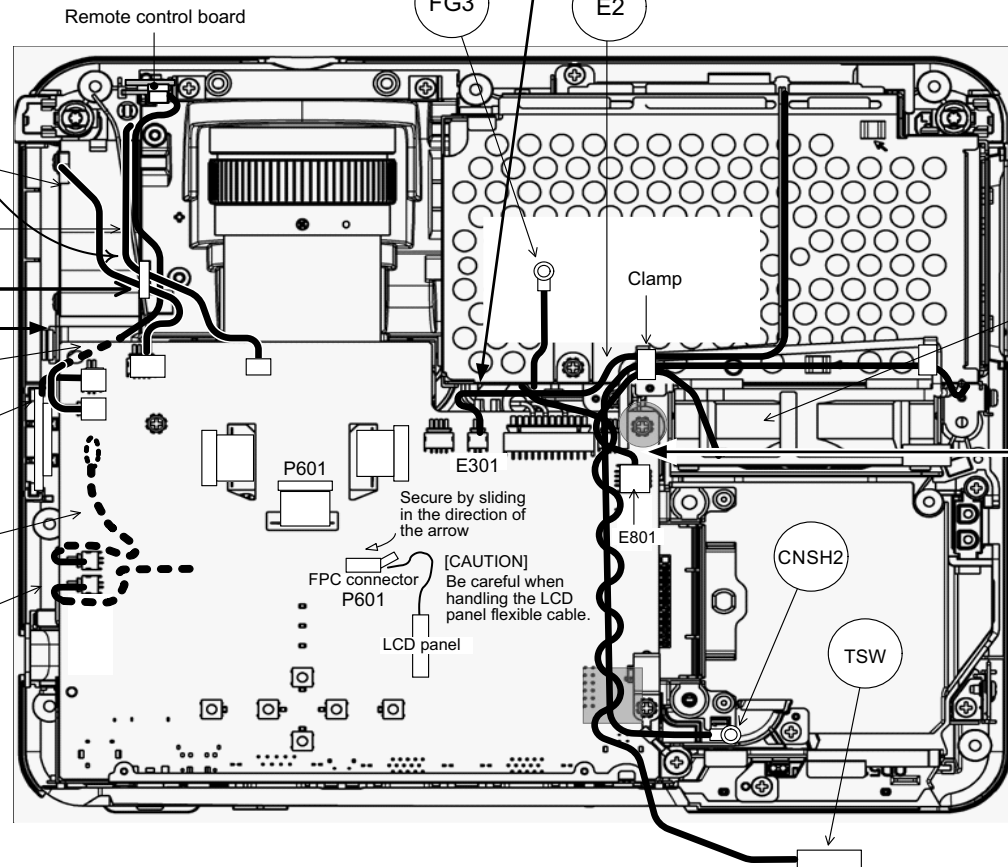

Wiring diagram 6

Wiring when attaching the circuit board shield.

When attaching the circuit board shield.

- (1) Connect and wire the CNSH.
- (2) Wire the TSW.
- (3) Connect the FG3.
- (4) Screw down the circuit board shield.

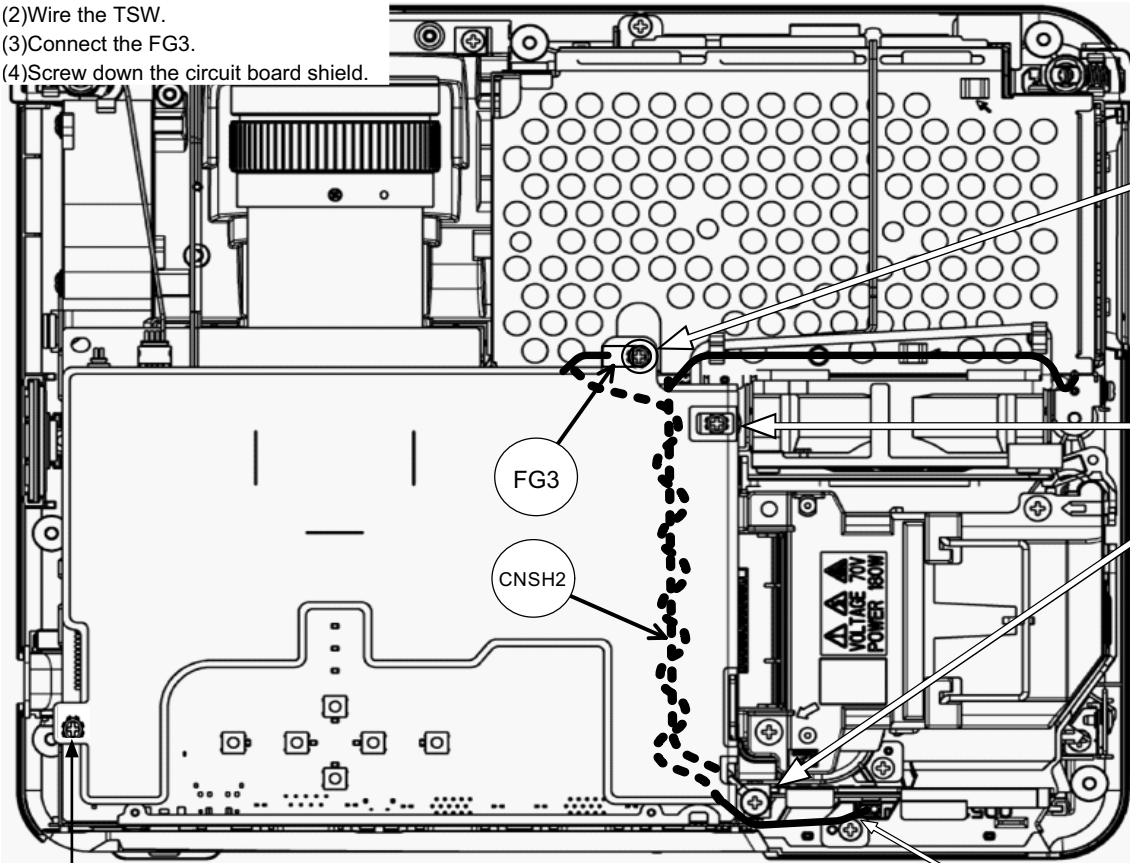

36

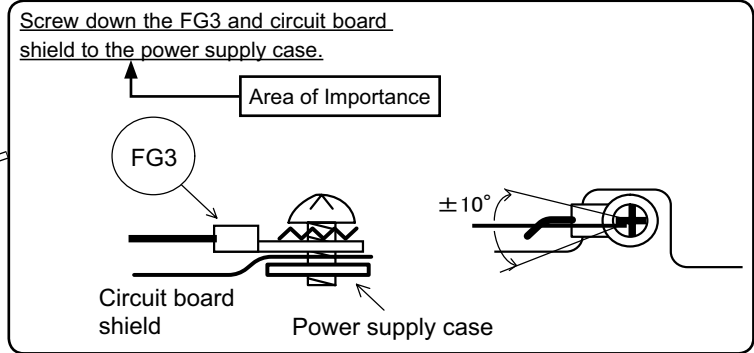

[CAUTION]
Confirm that the wires are not protruding to the screw area.

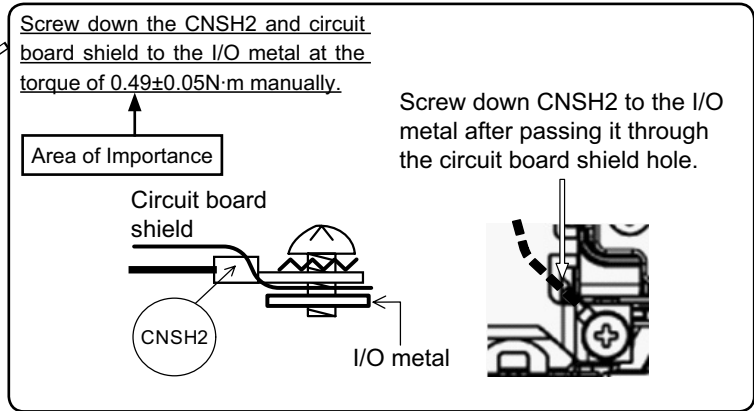

Make sure to screw down the circuit board shield.

Area of Importance

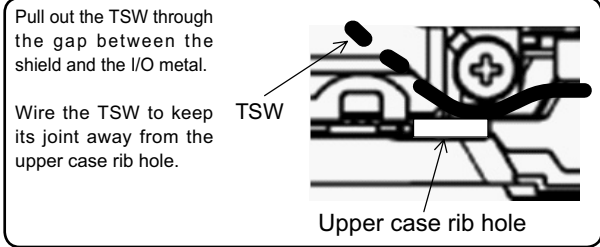

TSW Attach the TSW with the printed side facing the lamp.

Wiring diagram 7

8. Disassembly diagram

M: Meter screw
T: Tapping screw

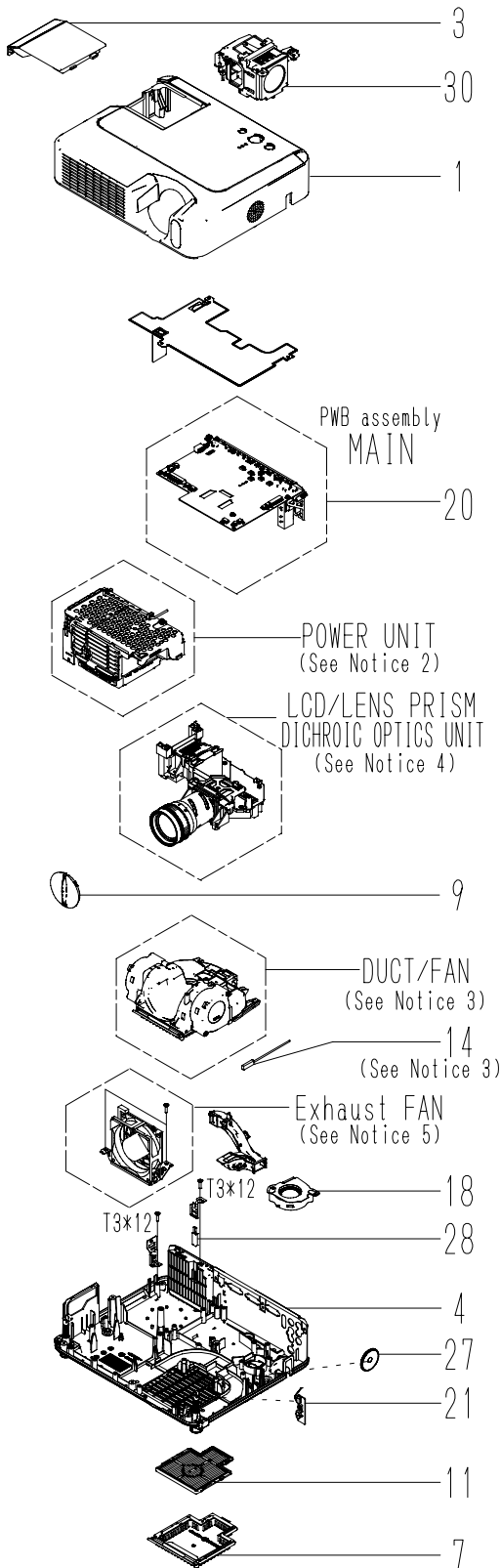

[Remove UPPER CASE]

T3×12 (△ See Notice 1)

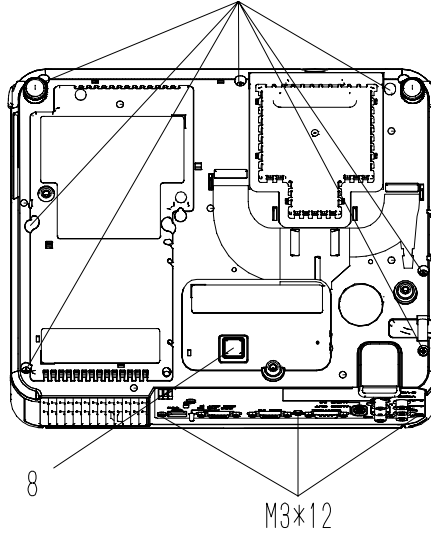

[Remove SHIELD of PWB assembly MAIN]

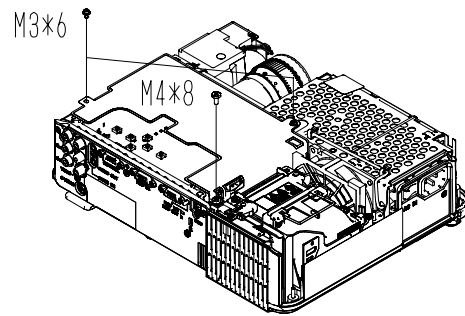

[PWB assembly MAIN]

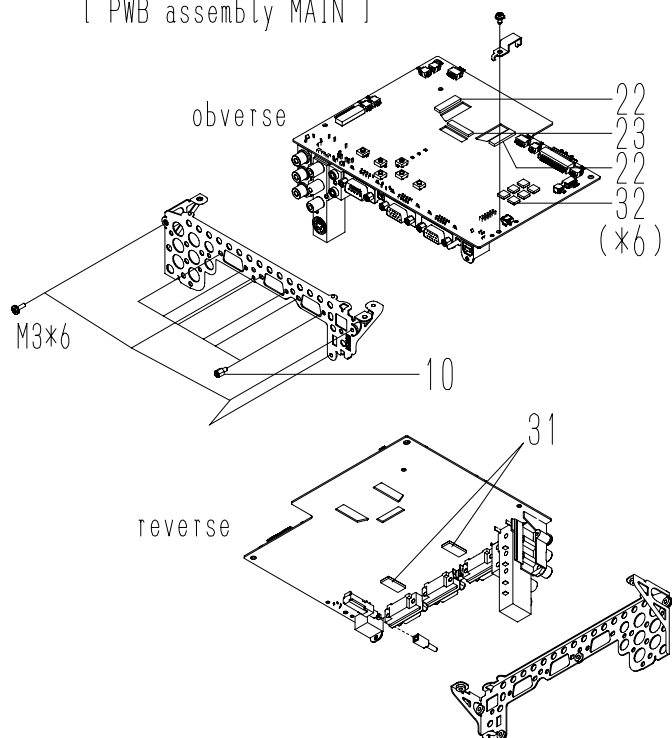

CP-S240(CC9SM)/CP-X250(CC9XM)

UPPER CASE assembly

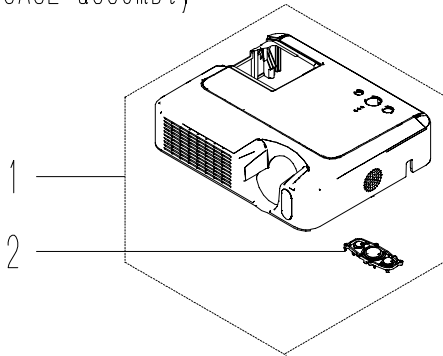

[Remove PANEL DUCT assembly]
(See Notice 3)

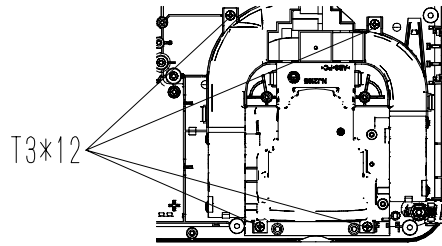

POWER UNIT
(See Notice 2)
[assembly]

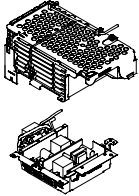

[disassembly]

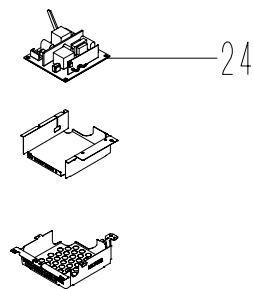
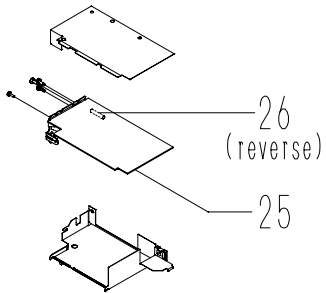
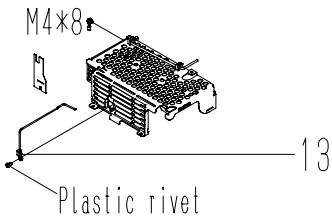

LCD/LENS/PRISM
DICHROIC OPTICS UNIT

[assembly]

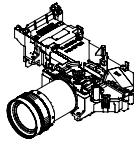

[disassembly]

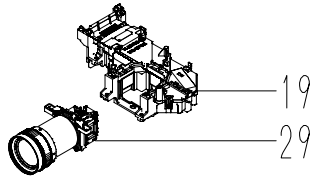

BOTTOM CASE assembly
[assembly]

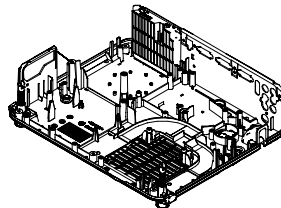

[disassembly]

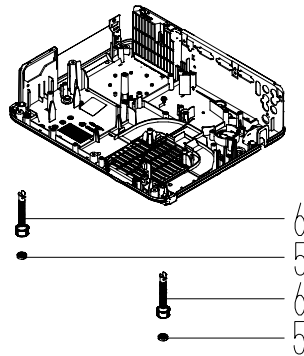

DUCT/FAN
(See Notice 3)
[assembly]

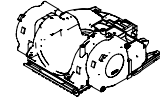

[disassembly]

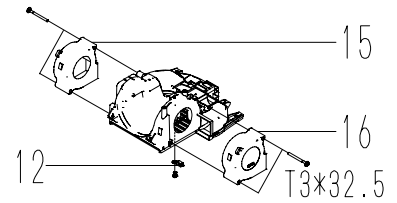

Exhaust FAN
(See Notice 5)

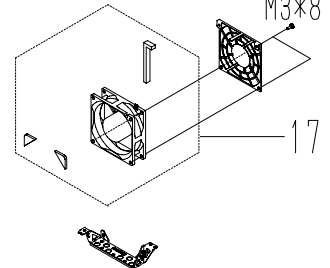

Notice

1. Detach and attach the upper case.

Follow the procedure below to detach and attach the upper case.

When disassembling

a. Remove the Lamp door.

CAUTION

The lamp door must be removed before the upper case when disassembling the machine. If the upper case is detached with the lamp door installed, the MAIN board might be damaged.

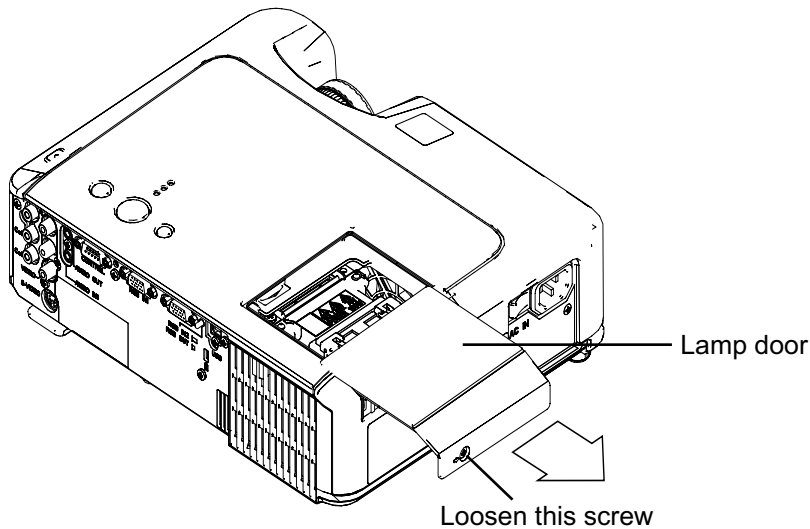

b. Remove 7 screws on the bottom and 3 screws on the rear to detach the upper case.

CAUTION

These are not screw holes. Do NOT insert a screw or screwdriver into them to avoid damaging the inside.

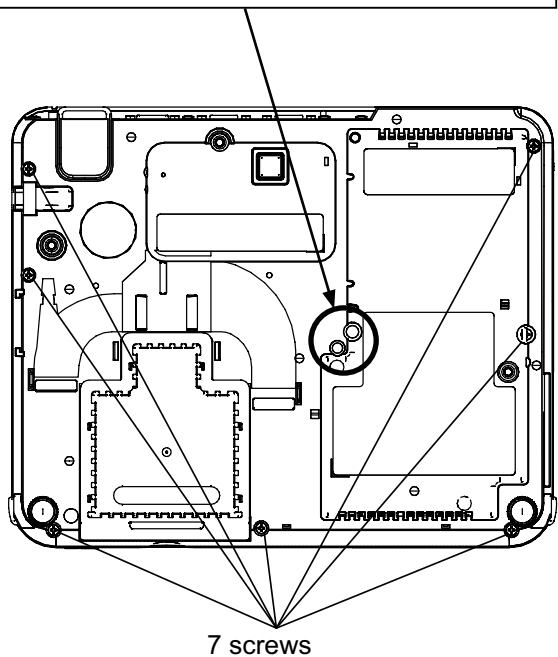
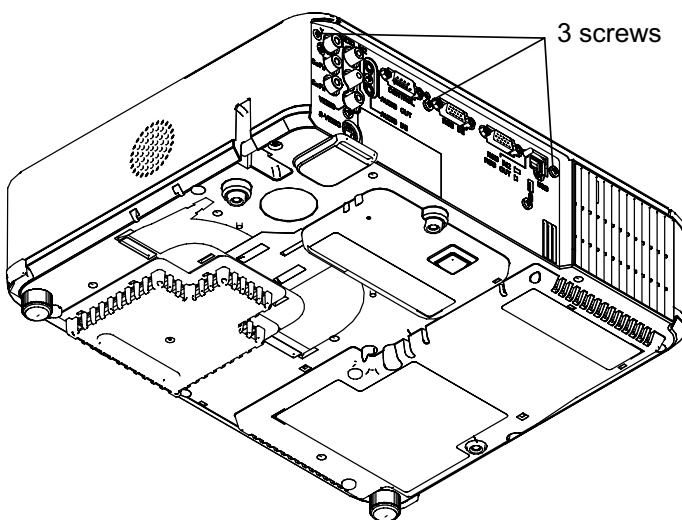

When assembling

a. Before attaching the upper case. Make sure that the speaker wires are routed correctly.

NOTICE :

Make sure that the soldering point of the wires and the speaker is within the shaded area as indicated in the drawing. Also, be careful not to change the original shape of speaker cone.

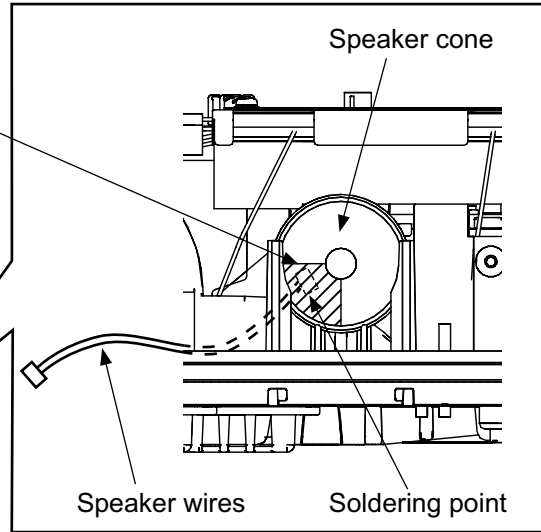
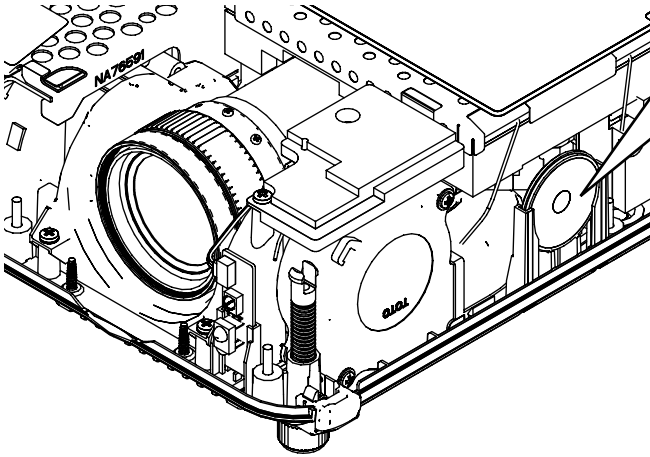

b. Tighten 7 screws on the bottom and 3 screws on the rear after attaching the upper case with the lamp door separated.

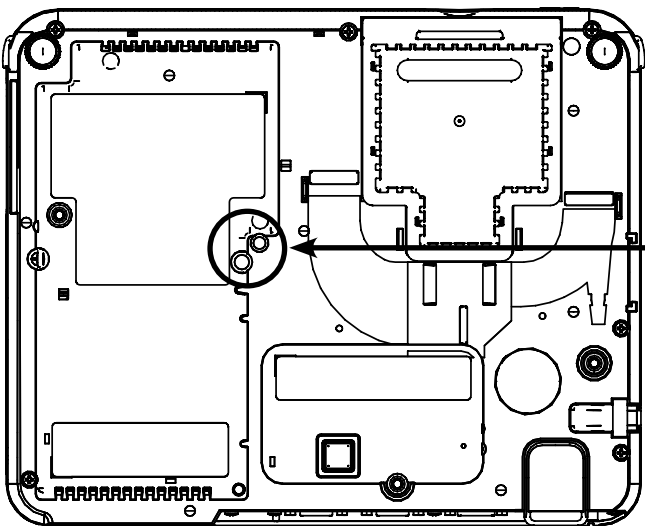

CAUTION
 These are not screw holes. Do NOT insert a screw or screwdriver into them to avoid damaging the inside.

In order not to make a gap between the upper and the bottom cases, tighten these screws while pressing down the upper case in the direction of the arrow. Be careful not to bend the outside casing.(Torque:0.39-0.59Nm)

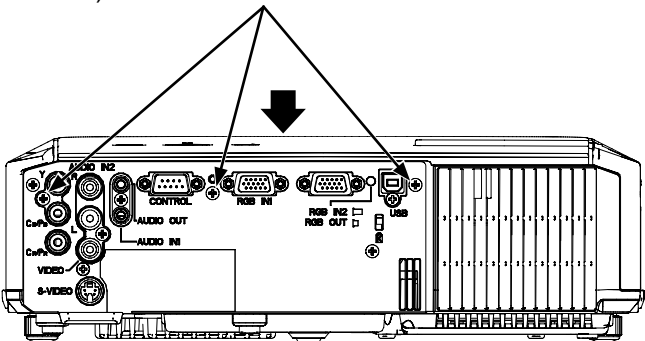

c. Attach the Lamp door.

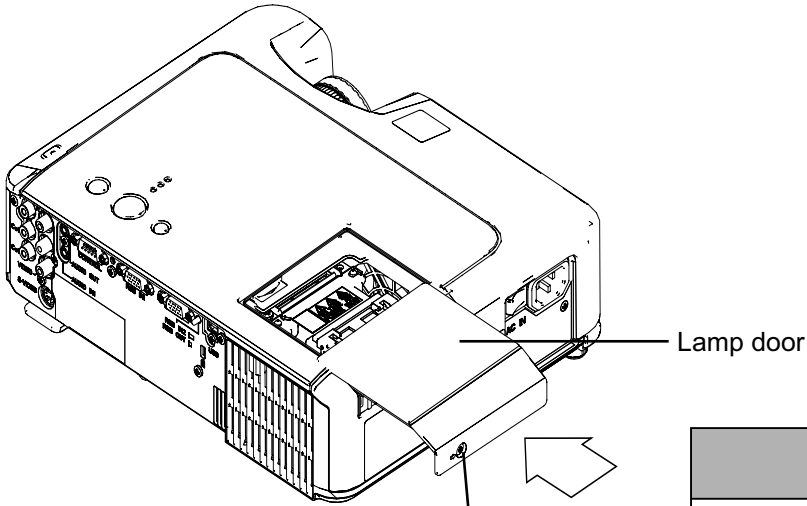

⚠ CAUTION

Tighten this screw using a manual screwdriver.

2. Replacing the power units.

Remove the 4 screws to take off the ballast bracket.

NOTE : One of screws is behind the Front Shade.

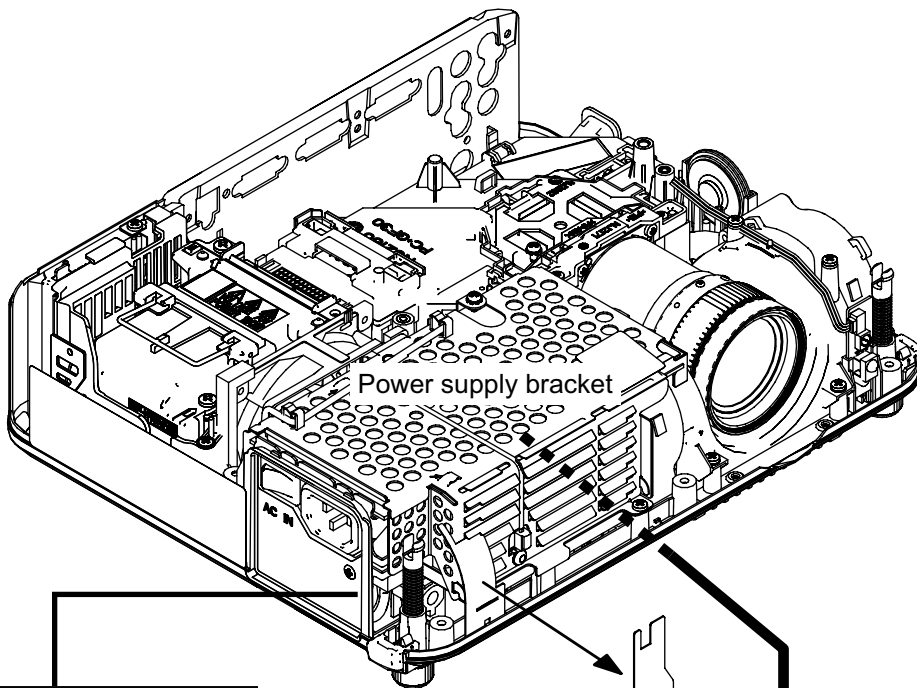

⚠ CAUTION

When re-assembling, tighten this screw at the torque of $0.49 \pm 0.1 \text{Nm}$ so that the bottom case does not strain.

⚠ CAUTION

The ballast bracket holding the ballast power unit is installed underneath the power supply bracket. Be careful not to injure your fingers or hand by the edges of the ballast bracket during maintenance around the power units.

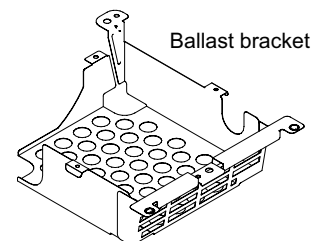

3. Detaching and attaching the Panel Fan Duct assembly

When disassembling

Remove 4 screws and unhook the panel fan duct assembly as shown in the diagram.

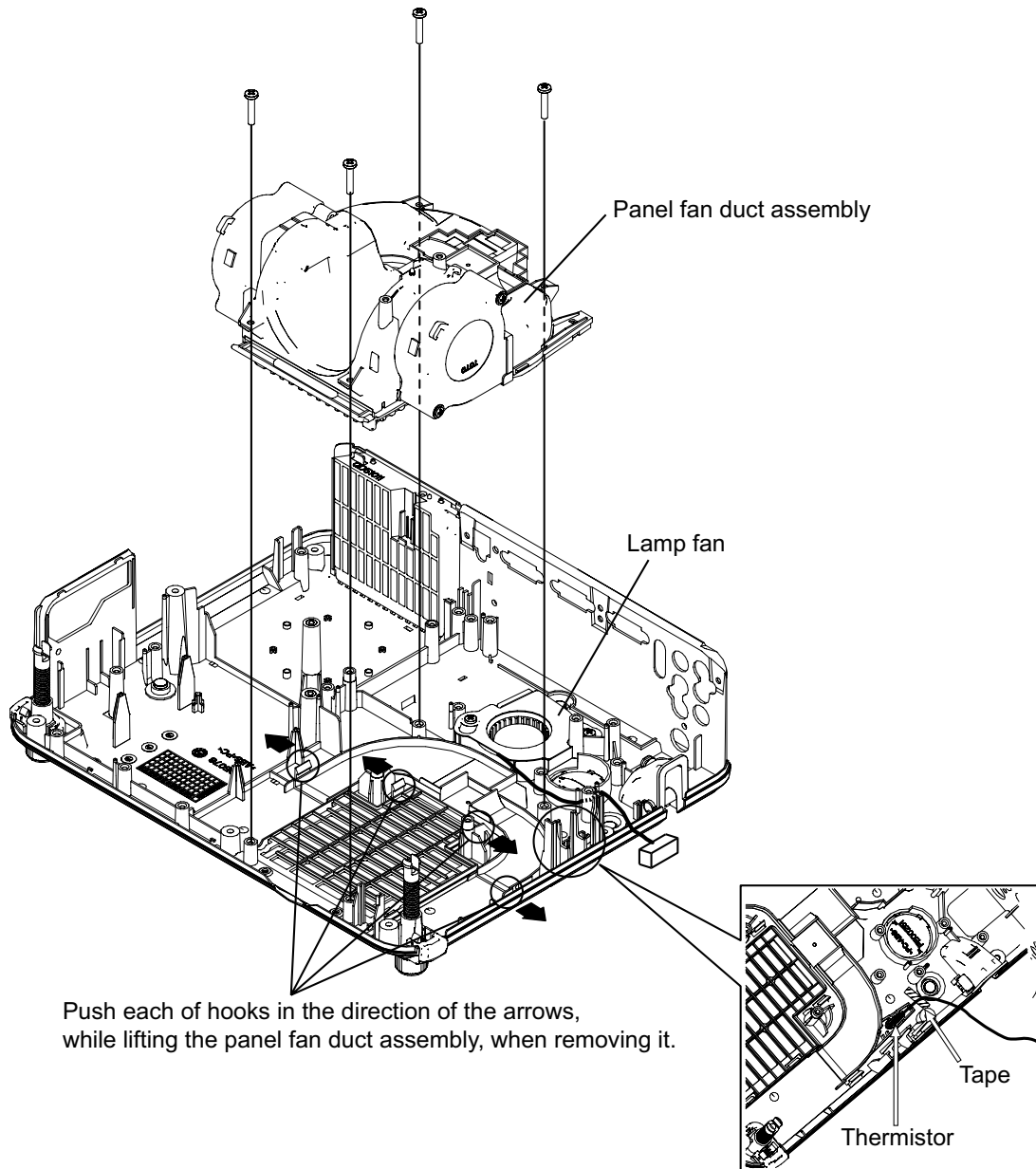

When assembling

- (1) Put the thermistor in the correct position on the bottom case and fasten its wire with tape as shown in the diagram.
- (2) Be careful not to put the lamp fan wires between the panel fan duct assembly and the bottom case in attaching the panel fan duct assembly.

4. Attaching the dichroic optics unit

Put the dichroic optics unit on the bottom case, and tighten screws in order of 1, 2, 3 and 4 as shown in the diagram.

Some of dichroic optics units have an extra hole shown in the diagram. Don't attach a screw to this hole. If you tighten it, the optical performance might become worse.

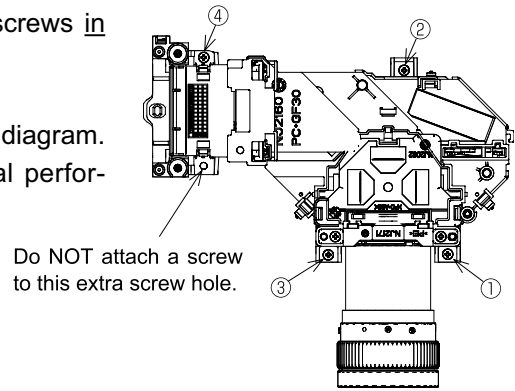

5. Replacing the exhaust fan

Be sure to do the following works before changing the exhaust fan.

a. Make sure the contents of the new exhaust fan assembly (P#: GS01321).

Exhaust fan1pcs

Fan cushion A 2pcs

Fan cushion B 1pcs

b. Assemble the exhaust fan and fan cushions as described below.

1) Attach the fan guard and the fan bracket to the new exhaust fan using 2 screws.

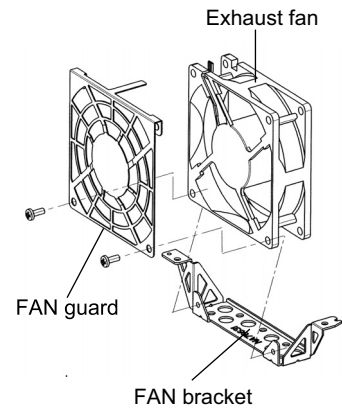

2) Stick two pieces of the fan cushion A to the corners of the fan.

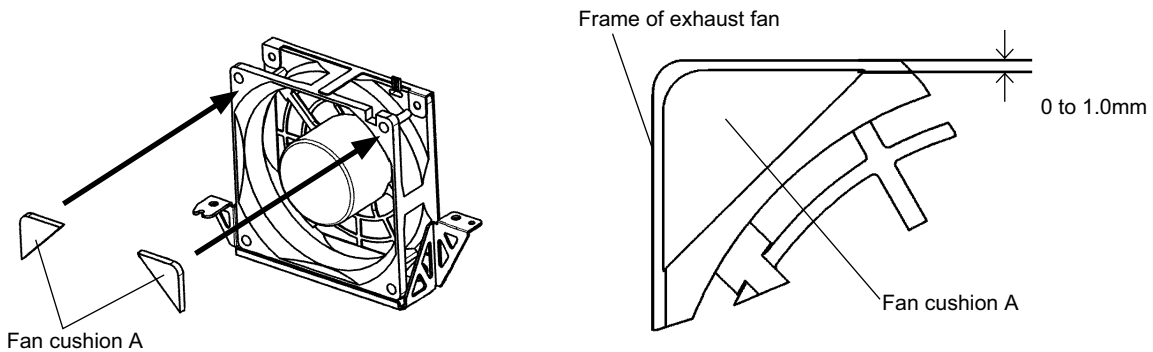

3) Stick the Fan cushion B along the top to side of the fan as shown in the diagram.

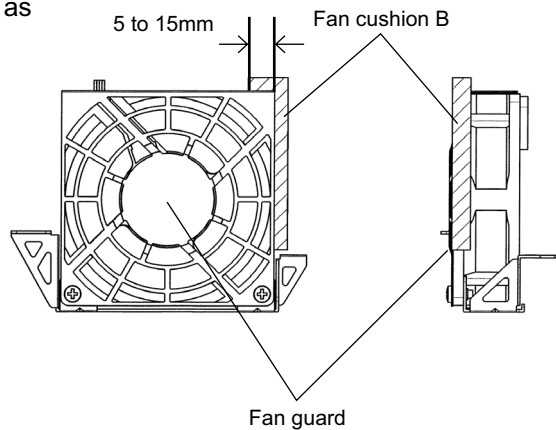

Note:

- If you install the new exhaust fan without the fan cushions, the fan vibration in operating might make noise.
- Be careful not to invert the fan when assembling the exhaust fan assembly.

**THE UPDATED PARTS LIST
FOR THIS MODEL IS
AVAILABLE ON ESTA**

CP-S240(CC9SM)/CP-X250(CC9XM)

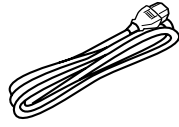

Power Cord

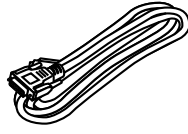

RGB Cable

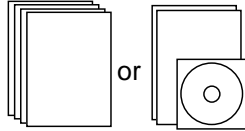

Instruction manual

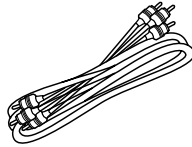

Audio/Video cable

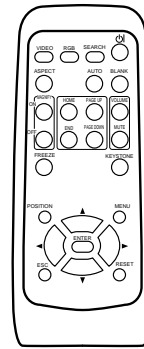

Remote Control

10. RS-232C communication

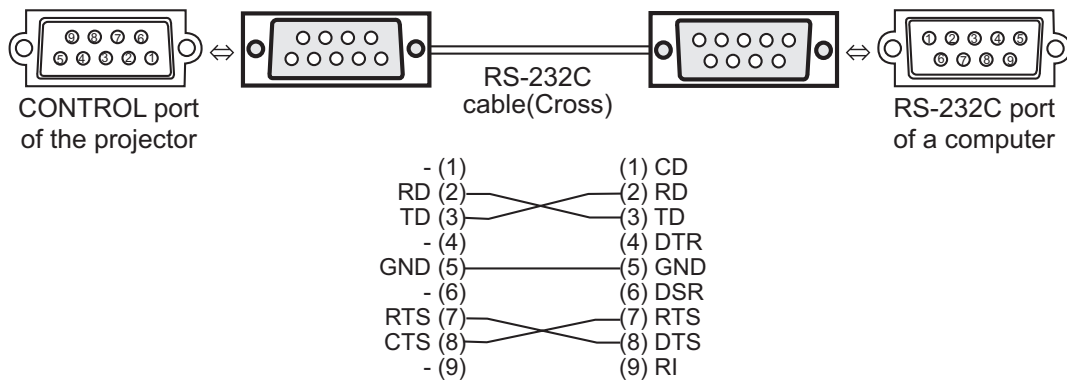

● Connecting the cable

- (1) Turn off the projector and the computer power supplies.
- (2) Connect the CONTROL port of the projector with a RS-232C port of the computer by a RS-232C cable(Cross). Use the cable that fulfills the specification shown in the previous page.
- (3) Turn on the computer power supply and after the computer has started up, turn on the projector power supply.

● Communications setting

19200 bps, 8N1

1. Protocol

Consist of header (7 bytes) + Command data (6 bytes)

2. Header

BE + EF + 03 + 06 + 00 + CRC_low + CRC_high

CRC_low: Lower byte of CRC flag for command data

CRC_high: Upper byte of CRC flag for command data

3. Command Data

Command Data Chart

byte_0	byte_1	byte_2	byte_3	byte_4	byte_5
Action		Type		Setting code	
low	high	low	high	low	high

Action (byte_0 - 1)

Action	Classification	Content
1	Set	Change setting to desired value.
2	Get	Read projector internal setup value.
4	Increment	Increment setup value by 1.
5	Decrement	Decrement setup value by 1.
6	Execute	Run a command.

CP-S240(CC9SM)/CP-X250(CC9XM)

Requesting projector status (Get command)

- (1) Send the request code Header + Command data ('02H'+ '00H'+ type (2 bytes)+ '00H'+ '00H') from the computer to the projector.
- (2) The projector returns the response code '1DH'+ data (2 bytes) to the computer.

Changing the projector settings (Set command)

- (1) Send the setting code Header + Command data ('01H'+ '00H'+ type (2 bytes) + setting code (2 bytes)) from the computer to the projector.
- (2) The projector changes the setting based on the above setting code.
- (3) The projector returns the response code '06H' to the computer.

Using the projector default settings (Reset Command)

- (1) The computer sends the default setting code Header + Command data ('06H'+ '00H'+ type (2 bytes) + '00H'+ '00H') to the projector.
- (2) The projector changes the specified setting to the default value.
- (3) The projector returns the response code '06H' to the computer.

Increasing the projector setting value (Increment command)

- (1) The computer sends the increment code Header + Command data ('04H'+ '00H'+ type (2 bytes) + '00H'+ '00H') to the projector.
- (2) The projector increases the setting value on the above setting code.
- (3) The projector returns the response code '06H' to the computer.

Decreasing the projector setting value (Decrement command)

- (1) The computer sends the decrement code Header + Command data ('05H'+ '00H'+ type (2 bytes) + '00H'+ '00H') to the projector.
- (2) The projector decreases the setting value on the above setting code.
- (3) The projector returns the response code '06H' to the computer.

When the projector cannot understand the received command

When the projector cannot understand the received command, the error code '15H' is sent back to the computer.

Sometimes the projector cannot properly receive the command. In such a case, the command is not executed and the error code '15H' is sent back to the computer. If this error code is returned, send the same command again.

When the projector cannot execute the received command.

When the projector cannot execute the received command, the error code '1cH' + 'xxxxH' is sent back to the computer. When the data length is greater than indicated by the data length code, the projector ignore the excess data code.

Conversely when the data length is shorter than indicated by the data length code, an error code will be returned to the computer.

- | |
|--|
| <p>NOTE • Operation cannot be guaranteed when the projector receives an undefined command or data.</p> <ul style="list-style-type: none">• Provide an interval of at least 40ms between the response code and any other code.• The projector outputs test data when the power supply is switched ON, and when the lamp is lit. Ignore this data.• Commands are not accepted during warm-up. |
|--|

CP-S240(CC9SM)/CP-X250(CC9XM)

● **Command data chart**

Names	Operation Type	Header				Command Data				
		CRC	Action	Type	Setting Code					
Power	Set	Turn off	BE EF	03	06 00	2A D3	01 00	00 60	00 00	
		Turn on	BE EF	03	06 00	BA D2	01 00	00 60	01 00	
	Get	BE EF	03	06 00	19 D3	02 00	00 60	00 00		
			(Example return)							
			00 00	01 00	02 00					
			(Off)	(On)	(Cool down)					
RGB2 Status	Get	BE EF	03	06 00	F1 D8	02 00	21 20	00 00		
		00 00	01 00							
		(RGB IN2)	(RGB OUT)							
Input Source	Set	RGB IN 1	BE EF	03	06 00	FE D2	01 00	00 20	00 00	
		RGB IN 2	BE EF	03	06 00	3E D0	01 00	00 20	04 00	
		VIDEO	BE EF	03	06 00	6E D3	01 00	00 20	01 00	
		S-VIDEO	BE EF	03	06 00	9E D3	01 00	00 20	02 00	
		COMPONENT	BE EF	03	06 00	AE D1	01 00	00 20	05 00	
	Get	BE EF	03	06 00	CD D2	02 00	00 20	00 00		
Error Status	Get	BE EF	03	06 00	D9 D8	02 00	20 60	00 00		
		(Example return)								
	00 00	01 00	02 00	03 00						
		(Normal)	(Cover error)	(Fan error)	(Lamp error)					
		04 00	05 00	06 00	07 00					
		(Temp error)	(Air flow error)	(Lamp time error)	(Cool error)					
		08 00	(Filter error)							
BRIGHTNESS	Get	BE EF	03	06 00	89 D2	02 00	03 20	00 00		
		Increment	BE EF	03	06 00	EF D2	04 00	03 20	00 00	
		Decrement	BE EF	03	06 00	3E D3	05 00	03 20	00 00	
BRIGHTNESS Reset	Execute	BE EF	03	06 00	58 D3	06 00	00 70	00 00		
CONTRAST	Get	BE EF	03	06 00	FD D3	02 00	04 20	00 00		
		Increment	BE EF	03	06 00	9B D3	04 00	04 20	00 00	
		Decrement	BE EF	03	06 00	4A D2	05 00	04 20	00 00	
CONTRAST Reset	Execute	BE EF	03	06 00	A4 D2	06 00	01 70	00 00		
MODE	Set	NORMAL	BE EF	03	06 00	23 F6	01 00	BA 30	00 00	
		CINEMA	BE EF	03	06 00	B3 F7	01 00	BA 30	01 00	
		DYNAMIC	BE EF	03	06 00	E3 F4	01 00	BA 30	04 00	
	Get	BE EF	03	06 00	10 F6	02 00	BA 30	00 00		
			(Example return)							
			00 00	01 00	04 00	10 00				
			(Normal)	(Cinema)	(Dynamic)	(Custom)				
GAMMA	Set	#1 DEFAULT	BE EF	03	06 00	07 E9	01 00	A1 30	20 00	
		#1 CUSTOM	BE EF	03	06 00	07 FD	01 00	A1 30	10 00	
		#2 DEFAULT	BE EF	03	06 00	97 E8	01 00	A1 30	21 00	
		#2 CUSTOM	BE EF	03	06 00	97 FC	01 00	A1 30	11 00	
		#3 DEFAULT	BE EF	03	06 00	67 E8	01 00	A1 30	22 00	
		#3 CUSTOM	BE EF	03	06 00	67 FC	01 00	A1 30	12 00	
	Get	BE EF	03	06 00	F4 F0	02 00	A1 30	00 00		

CP-S240(CC9SM)/CP-X250(CC9XM)

Names	Operation Type	Header				Command Data			
					CRC	Action	Type	Setting Code	
User Gamma Pattern	Set	Off	BE EF	03	06 00	FB FA	01 00	80 30	00 00
		9 step gray scale	BE EF	03	06 00	6B FB	01 00	80 30	01 00
		15 steps gray scale	BE EF	03	06 00	9B FB	01 00	80 30	02 00
		Ramp	BE EF	03	06 00	0B FA	01 00	80 30	03 00
	Get	BE EF	03	06 00	C8 FA	02 00	80 30	00 00	
User Gamma Point 1	Get	BE EF	03	06 00	08 FE	02 00	90 30	00 00	
	Increment	BE EF	03	06 00	6E FE	04 00	90 30	00 00	
	Decrement	BE EF	03	06 00	BF FF	05 00	90 30	00 00	
User Gamma Point 2	Get	BE EF	03	06 00	F4 FF	02 00	91 30	00 00	
	Increment	BE EF	03	06 00	92 FF	04 00	91 30	00 00	
	Decrement	BE EF	03	06 00	43 FE	05 00	91 30	00 00	
User Gamma Point 3	Get	BE EF	03	06 00	B0 FF	02 00	92 30	00 00	
	Increment	BE EF	03	06 00	D6 FF	04 00	92 30	00 00	
	Decrement	BE EF	03	06 00	07 FE	05 00	92 30	00 00	
User Gamma Point 4	Get	BE EF	03	06 00	4C FE	02 00	93 30	00 00	
	Increment	BE EF	03	06 00	2A FE	04 00	93 30	00 00	
	Decrement	BE EF	03	06 00	FB FF	05 00	93 30	00 00	
User Gamma Point 5	Get	BE EF	03	06 00	38 FF	02 00	94 30	00 00	
	Increment	BE EF	03	06 00	5E FF	04 00	94 30	00 00	
	Decrement	BE EF	03	06 00	8F FE	05 00	94 30	00 00	
User Gamma Point 6	Get	BE EF	03	06 00	C4 FE	02 00	95 30	00 00	
	Increment	BE EF	03	06 00	A2 FE	04 00	95 30	00 00	
	Decrement	BE EF	03	06 00	73 FF	05 00	95 30	00 00	
User Gamma Point 7	Get	BE EF	03	06 00	80 FE	02 00	96 30	00 00	
	Increment	BE EF	03	06 00	E6 FE	04 00	96 30	00 00	
	Decrement	BE EF	03	06 00	37 FF	05 00	96 30	00 00	
User Gamma Point 8	Get	BE EF	03	06 00	7C FF	02 00	97 30	00 00	
	Increment	BE EF	03	06 00	1A FF	04 00	97 30	00 00	
	Decrement	BE EF	03	06 00	CB FE	05 00	97 30	00 00	
COLOR TEMP	Set	LOW	BE EF	03	06 00	6B F4	01 00	B0 30	01 00
		MIDDLE	BE EF	03	06 00	9B F4	01 00	B0 30	02 00
		HIGH	BE EF	03	06 00	0B F5	01 00	B0 30	03 00
		CUSTOM	BE EF	03	06 00	3B F8	01 00	B0 30	10 00
	Get	BE EF	03	06 00	C8 F5	02 00	B0 30	00 00	
COLOR TEMP GAIN R	Get	BE EF	03	06 00	34 F4	02 00	B1 30	00 00	
	Increment	BE EF	03	06 00	52 F4	04 00	B1 30	00 00	
	Decrement	BE EF	03	06 00	83 F5	05 00	B1 30	00 00	

CP-S240(CC9SM)/CP-X250(CC9XM)

Names	Operation Type	Header				Command Data			
					CRC	Action	Type	Setting Code	
COLOR TEMP GAIN G	Get	BE EF	03	06 00	70 F4	02 00	B2 30	00 00	
	Increment	BE EF	03	06 00	16 F4	04 00	B2 30	00 00	
	Decrement	BE EF	03	06 00	C7 F5	05 00	B2 30	00 00	
COLOR TEMP GAIN B	Get	BE EF	03	06 00	8C F5	02 00	B3 30	00 00	
	Increment	BE EF	03	06 00	EA F5	04 00	B3 30	00 00	
	Decrement	BE EF	03	06 00	3B F4	05 00	B3 30	00 00	
COLOR TEMP OFFSET R	Get	BE EF	03	06 00	04 F5	02 00	B5 30	00 00	
	Increment	BE EF	03	06 00	62 F5	04 00	B5 30	00 00	
	Decrement	BE EF	03	06 00	B3 F4	05 00	B5 30	00 00	
COLOR TEMP OFFSET G	Get	BE EF	03	06 00	40 F5	02 00	B6 30	00 00	
	Increment	BE EF	03	06 00	26 F5	04 00	B6 30	00 00	
	Decrement	BE EF	03	06 00	F7 F4	05 00	B6 30	00 00	
COLOR TEMP OFFSET B	Get	BE EF	03	06 00	BC F4	02 00	B7 30	00 00	
	Increment	BE EF	03	06 00	DA F4	04 00	B7 30	00 00	
	Decrement	BE EF	03	06 00	0B F5	05 00	B7 30	00 00	
COLOR	Get	BE EF	03	06 00	B5 72	02 00	02 22	00 00	
	Increment	BE EF	03	06 00	D3 72	04 00	02 22	00 00	
	Decrement	BE EF	03	06 00	02 73	05 00	02 22	00 00	
COLOR Reset	Execute	BE EF	03	06 00	80 D0	06 00	0A 70	00 00	
TINT	Get	BE EF	03	06 00	49 73	02 00	03 22	00 00	
	Increment	BE EF	03	06 00	2F 73	04 00	03 22	00 00	
	Decrement	BE EF	03	06 00	FE 72	05 00	03 22	00 00	
TINT Reset	Execute	BE EF	03	06 00	7C D1	06 00	0B 70	00 00	
SHARPNESS	Get	BE EF	03	06 00	F1 72	02 00	01 22	00 00	
	Increment	BE EF	03	06 00	97 72	04 00	01 22	00 00	
	Decrement	BE EF	03	06 00	46 73	05 00	01 22	00 00	
SHARPNESS Reset	Execute	BE EF	03	06 00	C4 D0	06 00	09 70	00 00	
PROGRESSIVE	Set	TURN OFF	BE EF	03	06 00	4A 72	01 00	07 22	00 00
		TV	BE EF	03	06 00	DA 73	01 00	07 22	01 00
		FILM	BE EF	03	06 00	2A 73	01 00	07 22	02 00
	Get	BE EF	03	06 00	79 72	02 00	07 22	00 00	
MY MEMORY Load	Set	1	BE EF	03	06 00	0E D7	01 00	14 20	00 00
		2	BE EF	03	06 00	9E D6	01 00	14 20	01 00
		3	BE EF	03	06 00	6E D6	01 00	14 20	02 00
		4	BE EF	03	06 00	FE D7	01 00	14 20	03 00
MY MEMORY Save	Set	1	BE EF	03	06 00	F2 D6	01 00	15 20	00 00
		2	BE EF	03	06 00	62 D7	01 00	15 20	01 00
		3	BE EF	03	06 00	92 D7	01 00	15 20	02 00
		4	BE EF	03	06 00	02 D6	01 00	15 20	03 00

CP-S240(CC9SM)/CP-X250(CC9XM)

Names	Operation Type	Header				Command Data			
					CRC	Action	Type	Setting Code	
ASPECT	Set	4:3	BE EF	03	06 00	9E D0	01 00	08 20	00 00
		16:9	BE EF	03	06 00	0E D1	01 00	08 20	01 00
		SMALL	BE EF	03	06 00	FE D1	01 00	08 20	02 00
		NORMAL	BE EF	03	06 00	5E DD	01 00	08 20	10 00
	Get	BE EF	03	06 00	AD D0	02 00	08 20	00 00	
OVER SCAN	Get	BE EF	03	06 00	91 70	02 00	09 22	00 00	
	Increment	BE EF	03	06 00	F7 70	04 00	09 22	00 00	
	Decrement	BE EF	03	06 00	26 71	05 00	09 22	00 00	
OVER SCAN Reset	Execute	BE EF	03	06 00	EC D9	06 00	27 70	00 00	
V POSITION	Get	BE EF	03	06 00	0D 83	02 00	00 21	00 00	
	Increment	BE EF	03	06 00	6B 83	04 00	00 21	00 00	
	Decrement	BE EF	03	06 00	BA 82	05 00	00 21	00 00	
V POSITION Reset	Execute	BE EF	03	06 00	E0 D2	06 00	02 70	00 00	
H POSITION	Get	BE EF	03	06 00	F1 82	02 00	01 21	00 00	
	Increment	BE EF	03	06 00	97 82	04 00	01 21	00 00	
	Decrement	BE EF	03	06 00	46 83	05 00	01 21	00 00	
H POSITION Reset	Execute	BE EF	03	06 00	1C D3	06 00	03 70	00 00	
H PHASE	Get	BE EF	03	06 00	49 83	02 00	03 21	00 00	
	Increment	BE EF	03	06 00	2F 83	04 00	03 21	00 00	
	Decrement	BE EF	03	06 00	FE 82	05 00	03 21	00 00	
H SIZE	Get	BE EF	03	06 00	B5 82	02 00	02 21	00 00	
	Increment	BE EF	03	06 00	D3 82	04 00	02 21	00 00	
	Decrement	BE EF	03	06 00	02 83	05 00	02 21	00 00	
H SIZE Reset	Execute	BE EF	03	06 00	68 D2	06 00	04 70	00 00	
AUTO ADJUST	Execute	BE EF	03	06 00	91 D0	06 00	0A 20	00 00	
COLOR SPACE	Set	AUTO	BE EF	03	06 00	0E 72	01 00	04 22	00 00
		RGB	BE EF	03	06 00	9E 73	01 00	04 22	01 00
		SMPT240	BE EF	03	06 00	6E 73	01 00	04 22	02 00
		REC709	BE EF	03	06 00	FE 72	01 00	04 22	03 00
		REC601	BE EF	03	06 00	CE 70	01 00	04 22	04 00
	Get	BE EF	03	06 00	3D 72	02 00	04 22	00 00	
COMPONENT	Set	COMPONENT	BE EF	03	06 00	4A D7	01 00	17 20	00 00
		SCART RGB	BE EF	03	06 00	DA D6	01 00	17 20	01 00
		Get	BE EF	03	06 00	79 D7	02 00	17 20	00 00
VIDEO FORMAT	Set	AUTO	BE EF	03	06 00	9E 75	01 00	00 22	0A 00
		NTSC	BE EF	03	06 00	FE 71	01 00	00 22	04 00
		PAL	BE EF	03	06 00	6E 70	01 00	00 22	05 00
		SECAM	BE EF	03	06 00	6E 75	01 00	00 22	09 00
		NTSC4.43	BE EF	03	06 00	5E 72	01 00	00 22	02 00
		M-PAL	BE EF	03	06 00	FE 74	01 00	00 22	08 00
		N-PAL	BE EF	03	06 00	0E 71	01 00	00 22	07 00
	Get	BE EF	03	06 00	0D 73	02 00	00 22	00 00	
FRAME LOCK	Set	TURN OFF	BE EF	03	06 00	CB D6	01 00	14 30	00 00
		TURN ON	BE EF	03	06 00	5B D7	01 00	14 30	01 00
		Get	BE EF	03	06 00	F8 D6	02 00	14 30	00 00

CP-S240(CC9SM)/CP-X250(CC9XM)

Names	Operation Type	Header				Command Data			
					CRC	Action	Type	Setting Code	
KEYSTONE V	Get	BE EF	03	06 00	B9 D3	02 00	07 20	00 00	
	Increment	BE EF	03	06 00	DF D3	04 00	07 20	00 00	
	Decrement	BE EF	03	06 00	0E D2	05 00	07 20	00 00	
KEYSTONE V Reset	Execute	BE EF	03	06 00	08 D0	06 00	0C 70	00 00	
WHISPER	Set	NORMAL	BE EF	03	06 00	3B 23	01 00	00 33	00 00
		WHISPER	BE EF	03	06 00	AB 22	01 00	00 33	01 00
	Get	BE EF	03	06 00	08 23	02 00	00 33	00 00	
MIRROR	Set	NORMAL	BE EF	03	06 00	C7 D2	01 00	01 30	00 00
		H:INVERT	BE EF	03	06 00	57 D3	01 00	01 30	01 00
		V:INVERT	BE EF	03	06 00	A7 D3	01 00	01 30	02 00
		H&V:INVERT	BE EF	03	06 00	37 D2	01 00	01 30	03 00
	Get	BE EF	03	06 00	F4 D2	02 00	01 30	00 00	
VOLUME	Get	BE EF	03	06 00	31 D3	02 00	01 20	00 00	
	Increment	BE EF	03	06 00	57 D3	04 00	01 20	00 00	
	Decrement	BE EF	03	06 00	86 D2	05 00	01 20	00 00	
AUDIO - RGB1	Set	TURN OFF	BE EF	03	06 00	FE DD	01 00	30 20	00 00
		Audio1	BE EF	03	06 00	6E DC	01 00	30 20	01 00
		Audio2	BE EF	03	06 00	9E DC	01 00	30 20	02 00
	Get	BE EF	03	06 00	CD DD	02 00	30 20	00 00	
AUDIO - RGB2	Set	TURN OFF	BE EF	03	06 00	CE DC	01 00	34 20	00 00
		Audio1	BE EF	03	06 00	5E DD	01 00	34 20	01 00
		Audio2	BE EF	03	06 00	AE DD	01 00	34 20	02 00
	Get	BE EF	03	06 00	FD DC	02 00	34 20	00 00	
AUDIO - Video	Set	TURN OFF	BE EF	03	06 00	02 DC	01 00	31 20	00 00
		Audio1	BE EF	03	06 00	92 DD	01 00	31 20	01 00
		Audio2	BE EF	03	06 00	62 DD	01 00	31 20	02 00
	Get	BE EF	03	06 00	31 DC	02 00	31 20	00 00	
AUDIO - S-Video	Set	TURN OFF	BE EF	03	06 00	46 DC	01 00	32 20	00 00
		Audio1	BE EF	03	06 00	D6 DD	01 00	32 20	01 00
		Audio2	BE EF	03	06 00	26 DD	01 00	32 20	02 00
	Get	BE EF	03	06 00	75 DC	02 00	32 20	00 00	
AUDIO - Component	Set	TURN OFF	BE EF	03	06 00	32 DD	01 00	35 20	00 00
		Audio1	BE EF	03	06 00	A2 DC	01 00	35 20	01 00
		Audio2	BE EF	03	06 00	52 DC	01 00	35 20	02 00
	Get	BE EF	03	06 00	01 DD	02 00	35 20	00 00	

CP-S240(CC9SM)/CP-X250(CC9XM)

Names	Operation Type	Header				Command Data			
					CRC	Action	Type	Setting Code	
MUTE	Set	TURN OFF	BE EF	03	06 00	46 D3	01 00	02 20	00 00
		TURN ON	BE EF	03	06 00	D6 D2	01 00	02 20	01 00
	Get	BE EF	03	06 00	75 D3	02 00	02 20	00 00	
LANGUAGE	Set	ENGLISH	BE EF	03	06 00	F7 D3	01 00	05 30	00 00
		FRANÇAIS	BE EF	03	06 00	67 D2	01 00	05 30	01 00
		DEUTSCH	BE EF	03	06 00	97 D2	01 00	05 30	02 00
		ESPAÑOL	BE EF	03	06 00	07 D3	01 00	05 30	03 00
		ITALIANO	BE EF	03	06 00	37 D1	01 00	05 30	04 00
		NORSK	BE EF	03	06 00	A7 D0	01 00	05 30	05 00
		NEDERLANDS	BE EF	03	06 00	57 D0	01 00	05 30	06 00
		PORTUGUÊS	BE EF	03	06 00	C7 D1	01 00	05 30	07 00
		日本語	BE EF	03	06 00	37 D4	01 00	05 30	08 00
		简体中文	BE EF	03	06 00	A7 D5	01 00	05 30	09 00
		繁體中文	BE EF	03	06 00	37 DE	01 00	05 30	10 00
		한글	BE EF	03	06 00	57 D5	01 00	05 30	0A 00
		SVENSKA	BE EF	03	06 00	C7 D4	01 00	05 30	0B 00
		РУССКИЙ	BE EF	03	06 00	F7 D6	01 00	05 30	0C 00
		SUOMI	BE EF	03	06 00	67 D7	01 00	05 30	0D 00
	POLSKI	BE EF	03	06 00	97 D7	01 00	05 30	0E 00	
TÜRKÇE	BE EF	03	06 00	07 D6	01 00	05 30	0F 00		
	Get	BE EF	03	06 00	C4 D3	02 00	05 30	00 00	
MENU POSITION H	Get	BE EF	03	06 00	04 D7	02 00	15 30	00 00	
	Increment	BE EF	03	06 00	62 D7	04 00	15 30	00 00	
	Decrement	BE EF	03	06 00	B3 D6	05 00	15 30	00 00	
MENU POSITION H Reset	Execute	BE EF	03	06 00	DC C6	06 00	43 70	00 00	
MENU POSITION V	Get	BE EF	03	06 00	40 D7	02 00	16 30	00 00	
	Increment	BE EF	03	06 00	26 D7	04 00	16 30	00 00	
	Decrement	BE EF	03	06 00	F7 D6	05 00	16 30	00 00	
MENU POSITION V Reset	Execute	BE EF	03	06 00	A8 C7	06 00	44 70	00 00	

CP-S240(CC9SM)/CP-X250(CC9XM)

Names	Operation Type	Header				Command Data			
					CRC	Action	Type	Setting Code	
OSD BRIGHT.		Get	BE EF	03	06 00	A8 D5	02 00	18 30	00 00
		Increment	BE EF	03	06 00	CE D5	04 00	18 30	00 00
		Decrement	BE EF	03	06 00	1F D4	05 00	18 30	00 00
BLANK	Set	My Screen	BE EF	03	06 00	FB CA	01 00	00 30	20 00
		ORIGINAL	BE EF	03	06 00	FB E2	01 00	00 30	40 00
		BLUE	BE EF	03	06 00	CB D3	01 00	00 30	03 00
		WHITE	BE EF	03	06 00	6B D0	01 00	00 30	05 00
		BLACK	BE EF	03	06 00	9B D0	01 00	00 30	06 00
		Get	BE EF	03	06 00	08 D3	02 00	00 30	00 00
BLANK On/Off	Set	TURN OFF	BE EF	03	06 00	FB D8	01 00	20 30	00 00
		TURN ON	BE EF	03	06 00	6B D9	01 00	20 30	01 00
			Get	BE EF	03	06 00	C8 D8	02 00	20 30
START UP	Set	My Screen	BE EF	03	06 00	CB CB	01 00	04 30	20 00
		ORIGINAL	BE EF	03	06 00	0B D2	01 00	04 30	00 00
		TURN OFF	BE EF	03	06 00	9B D3	01 00	04 30	01 00
			Get	BE EF	03	06 00	38 D2	02 00	04 30
My Screen LOCK	Set	TURN OFF	BE EF	03	06 00	3B EF	01 00	C0 30	00 00
		TURN ON	BE EF	03	06 00	AB EE	01 00	C0 30	01 00
			Get	BE EF	03	06 00	08 EF	02 00	C0 30
Message	Set	TURN OFF	BE EF	03	06 00	8F D6	01 00	17 30	00 00
		TURN ON	BE EF	03	06 00	1F D7	01 00	17 30	01 00
			Get	BE EF	03	06 00	BC D6	02 00	17 30
AUTO SEARCH	Set	TURN OFF	BE EF	03	06 00	B6 D6	01 00	16 20	00 00
		TURN ON	BE EF	03	06 00	26 D7	01 00	16 20	01 00
			Get	BE EF	03	06 00	85 D6	02 00	16 20
AUTO POWER OFF		Get	BE EF	03	06 00	08 86	02 00	10 31	00 00
		Increment	BE EF	03	06 00	6E 86	04 00	10 31	00 00
		Decrement	BE EF	03	06 00	BF 87	05 00	10 31	00 00
LAMP TIME		Get	BE EF	03	06 00	C2 FF	02 00	90 10	00 00
LAMP TIME Reset		Execute	BE EF	03	06 00	58 DC	06 00	30 70	00 00
FILTER TIME		Get	BE EF	03	06 00	C2 F0	02 00	A0 10	00 00
FILER TIME Reset		Execute	BE EF	03	06 00	98 C6	06 00	40 70	00 00
MAGNIFY		Get	BE EF	03	06 00	7C D2	02 00	07 30	00 00
		Increment	BE EF	03	06 00	1A D2	04 00	07 30	00 00
		Decrement	BE EF	03	06 00	CB D3	05 00	07 30	00 00
FREEZE	Set	NORMAL	BE EF	03	06 00	83 D2	01 00	02 30	00 00
		FREEZE	BE EF	03	06 00	13 D3	01 00	02 30	01 00
		Get	BE EF	03	06 00	B0 D2	02 00	02 30	00 00

11. Block diagram

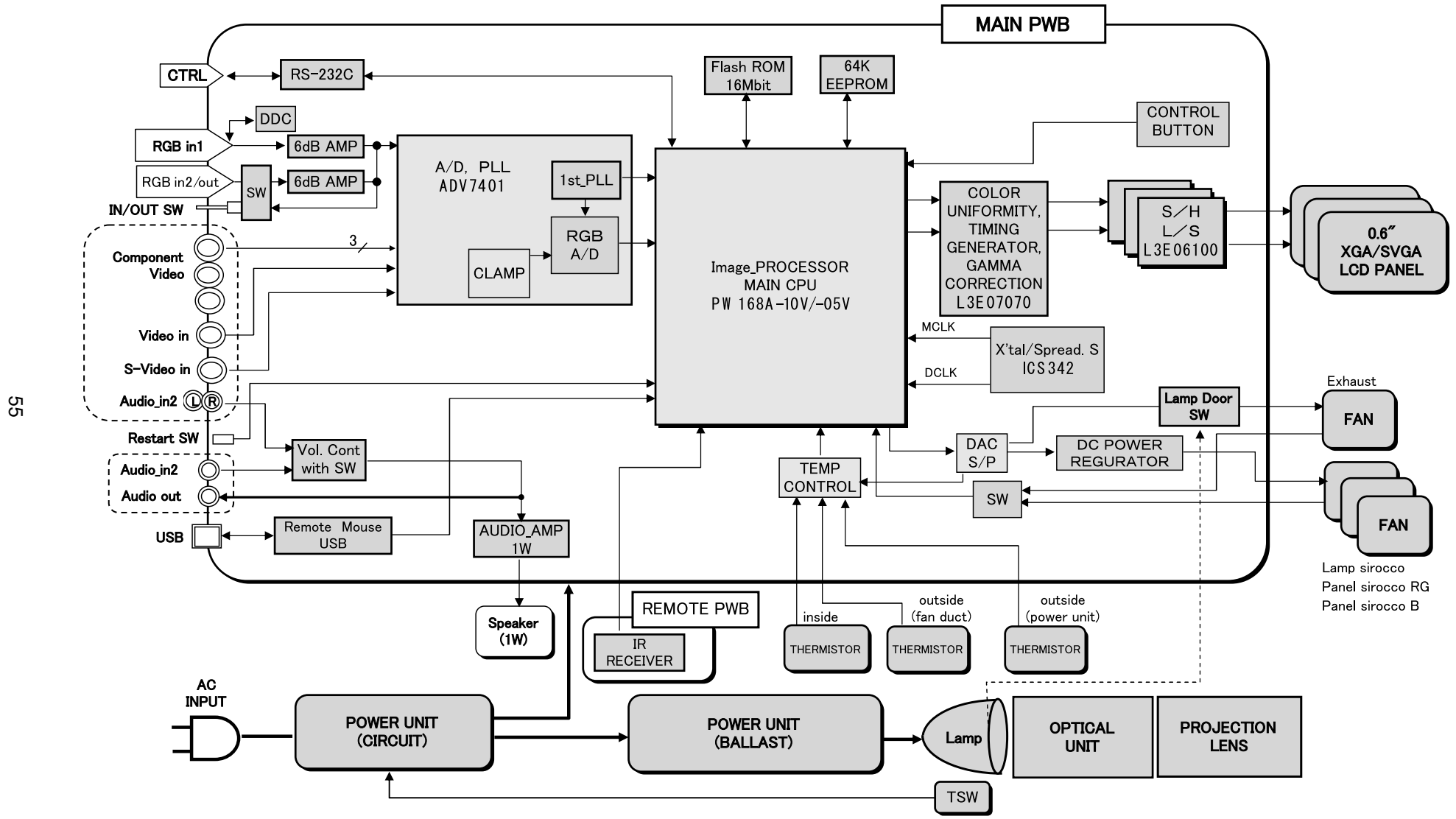

Block diagram

12. Connector connection diagram

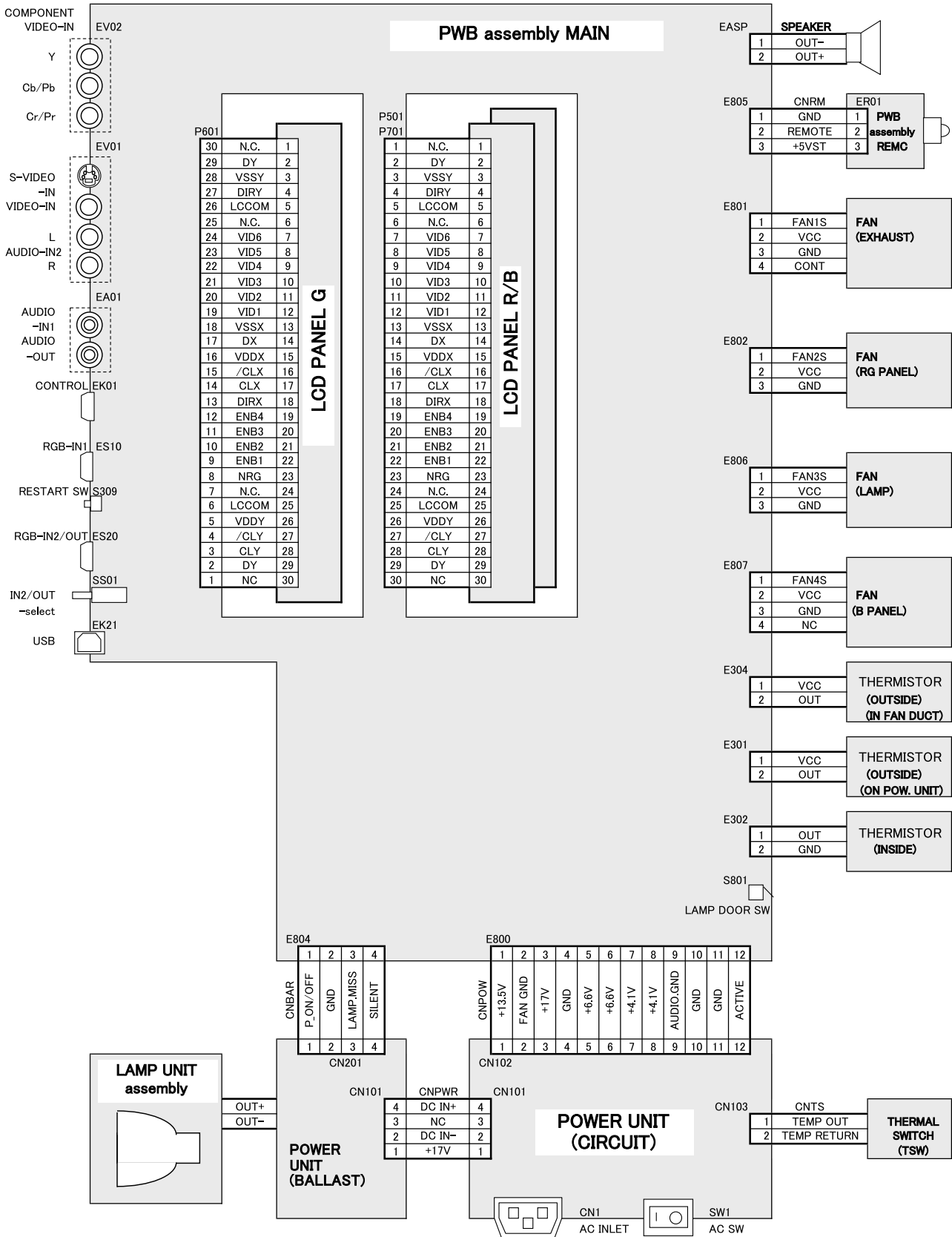

Connector connection diagram

13. Basic circuit diagram

Parts with hatching are not mounted.

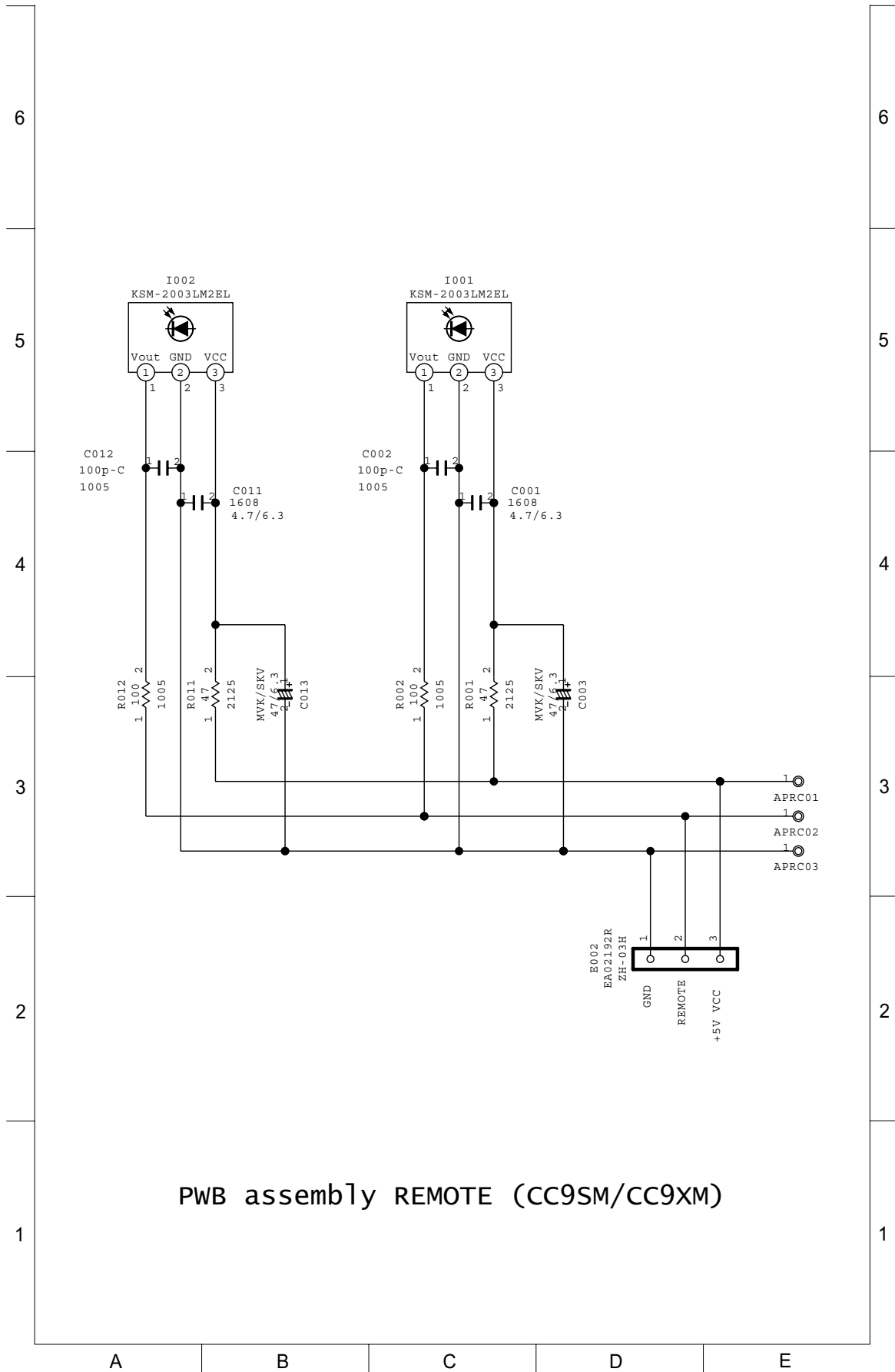

MEMO

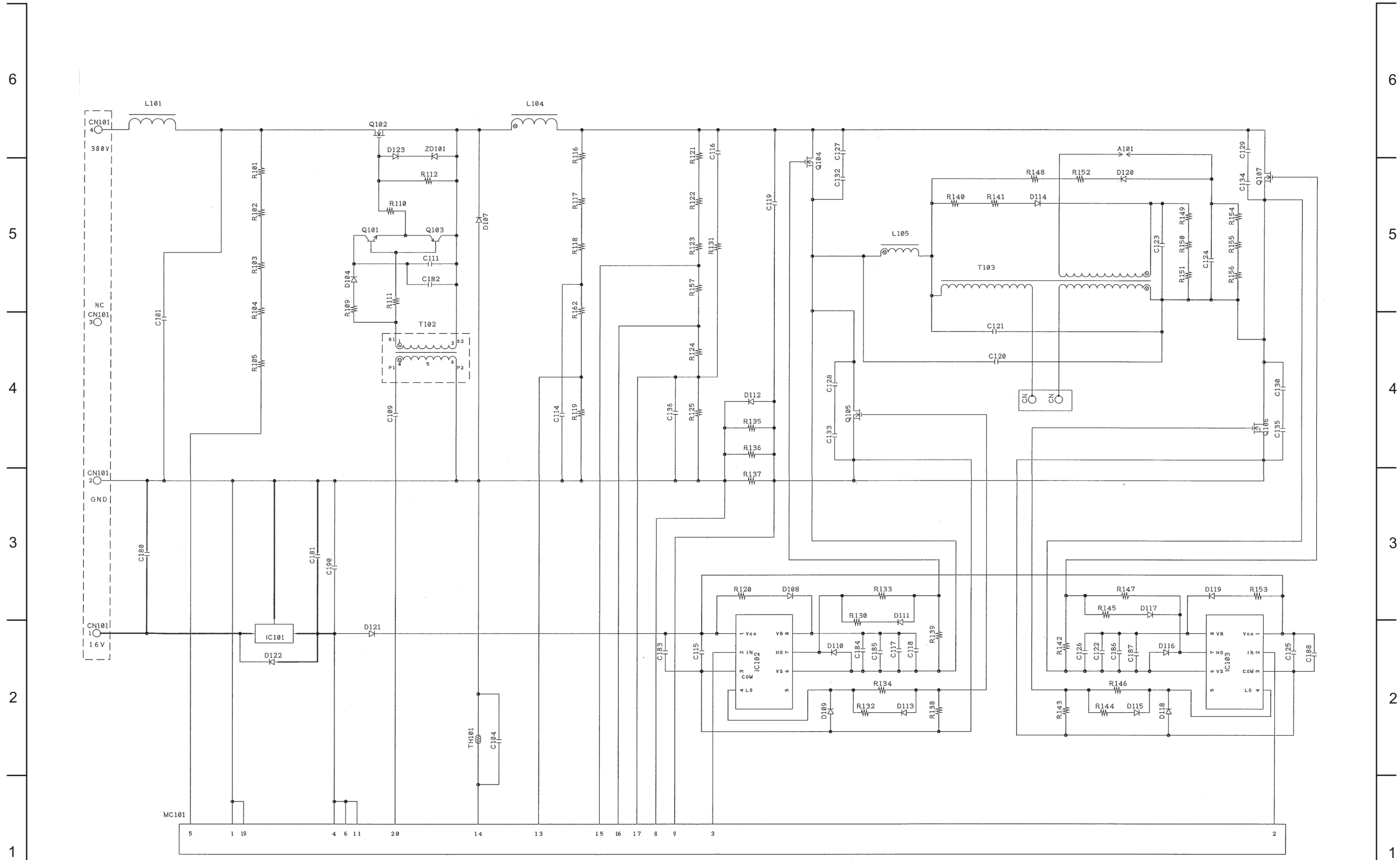

Warning
 For handling of the circuit diagram, refer to the warning on the cover.

POWER UNIT (BALLAST) 1 (CC9SM/CC9XM)

A B C D E F G

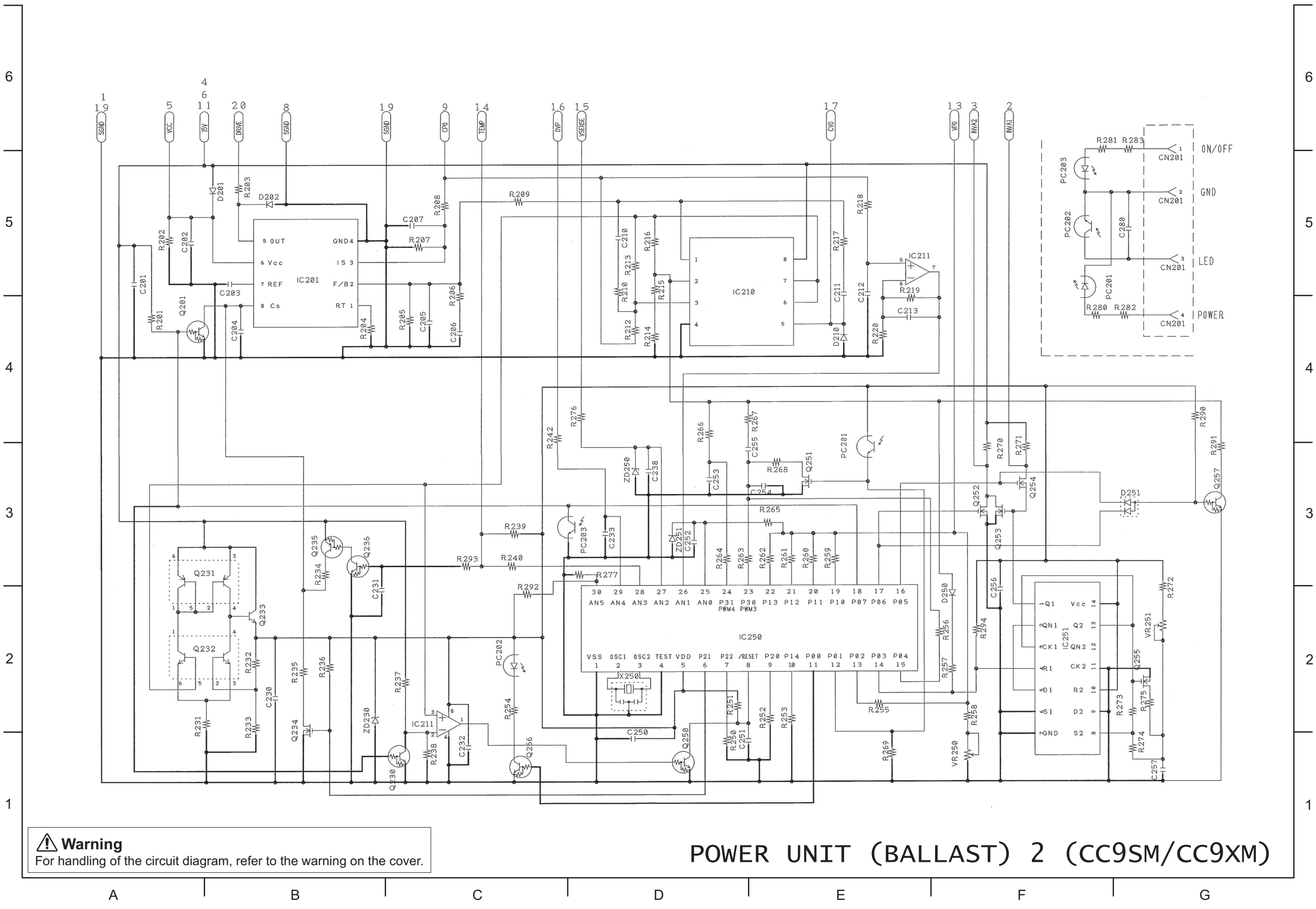

Warning
 For handling of the circuit diagram, refer to the warning on the cover.

POWER UNIT (BALLAST) 2 (CC9SM/CC9XM)

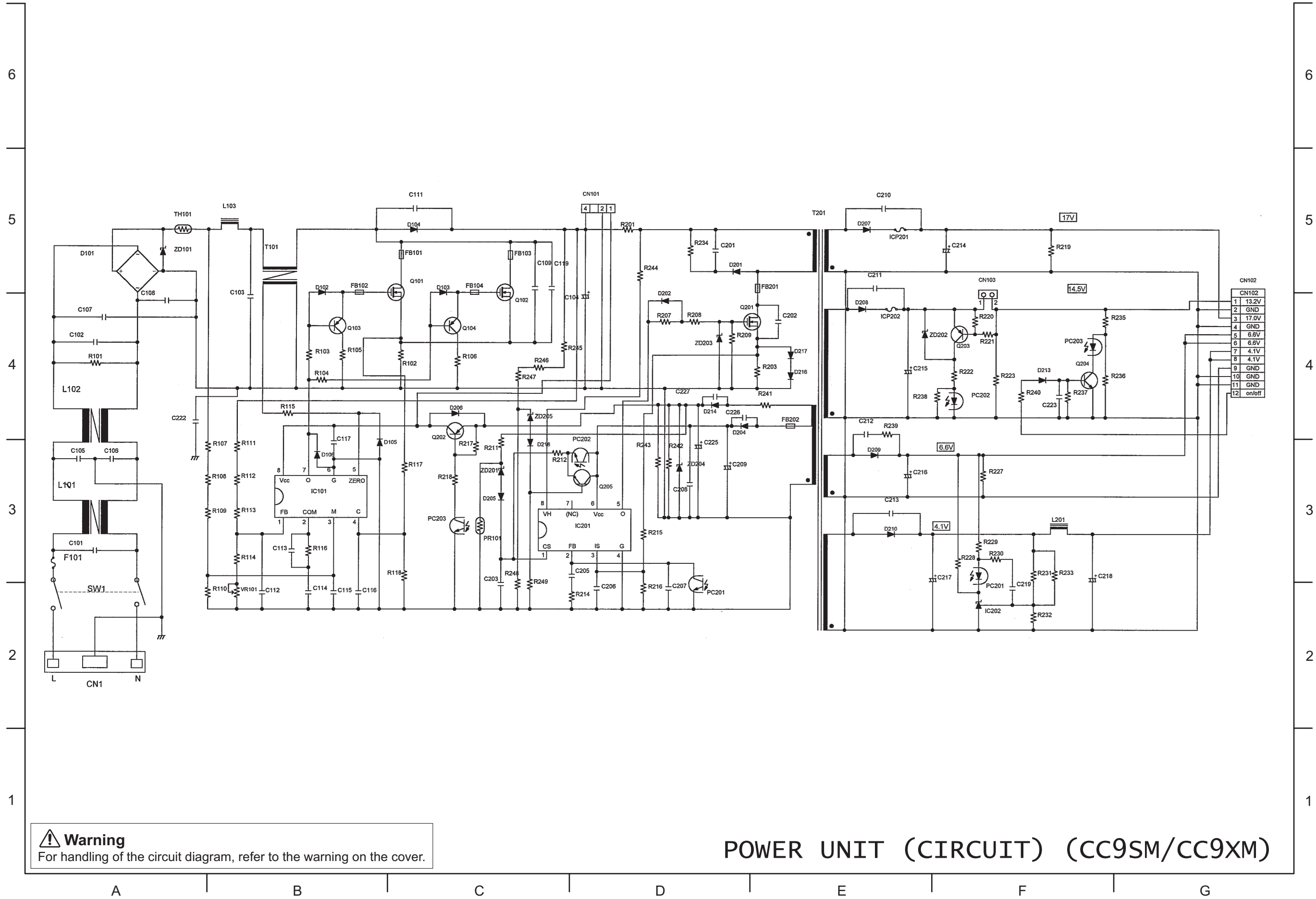

Warning
 For handling of the circuit diagram, refer to the warning on the cover.

POWER UNIT (CIRCUIT) (CC9SM/CC9XM)

A | B | C | D | E | F | G

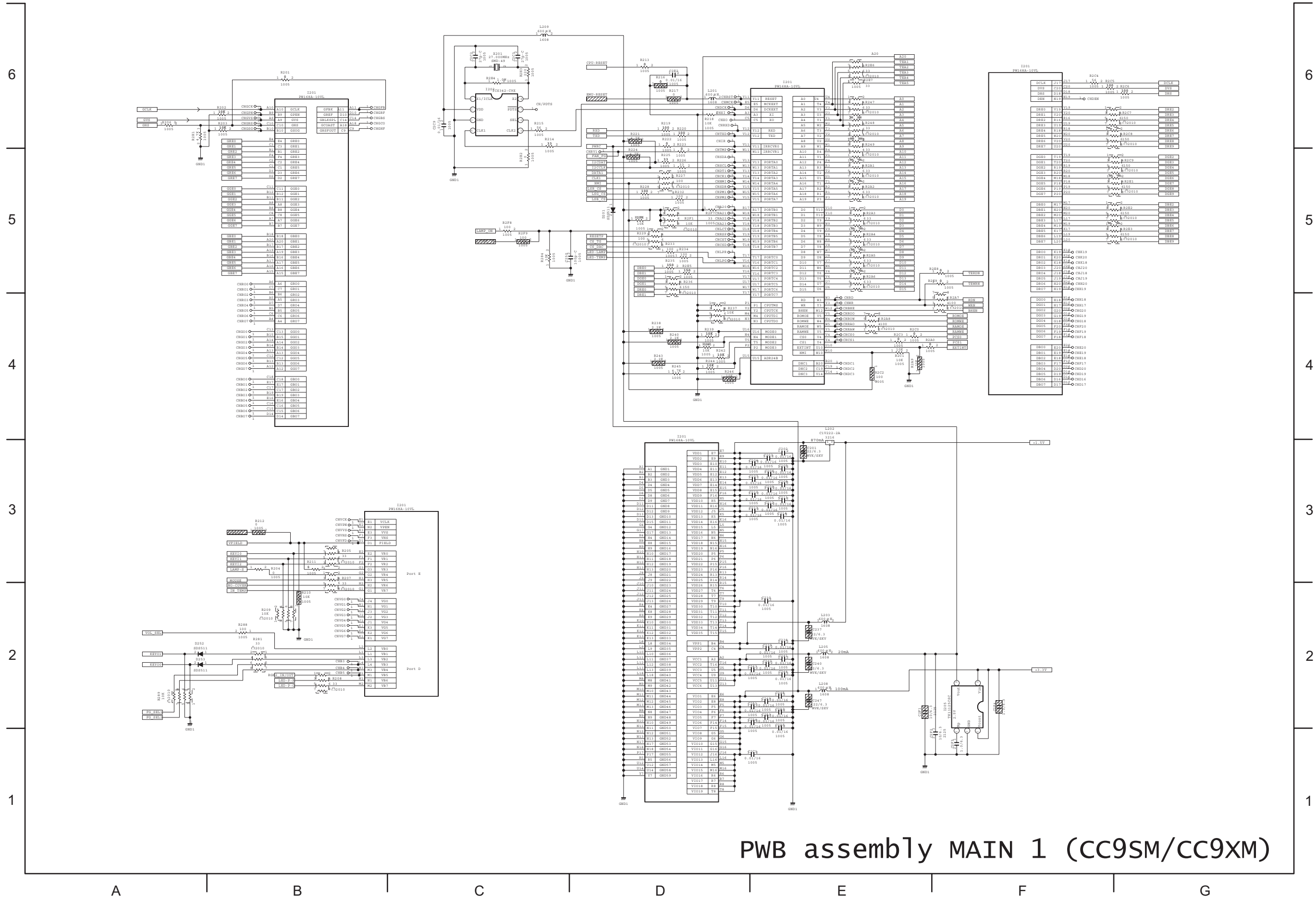

PWB assembly MAIN 1 (CC9SM/CC9XM)

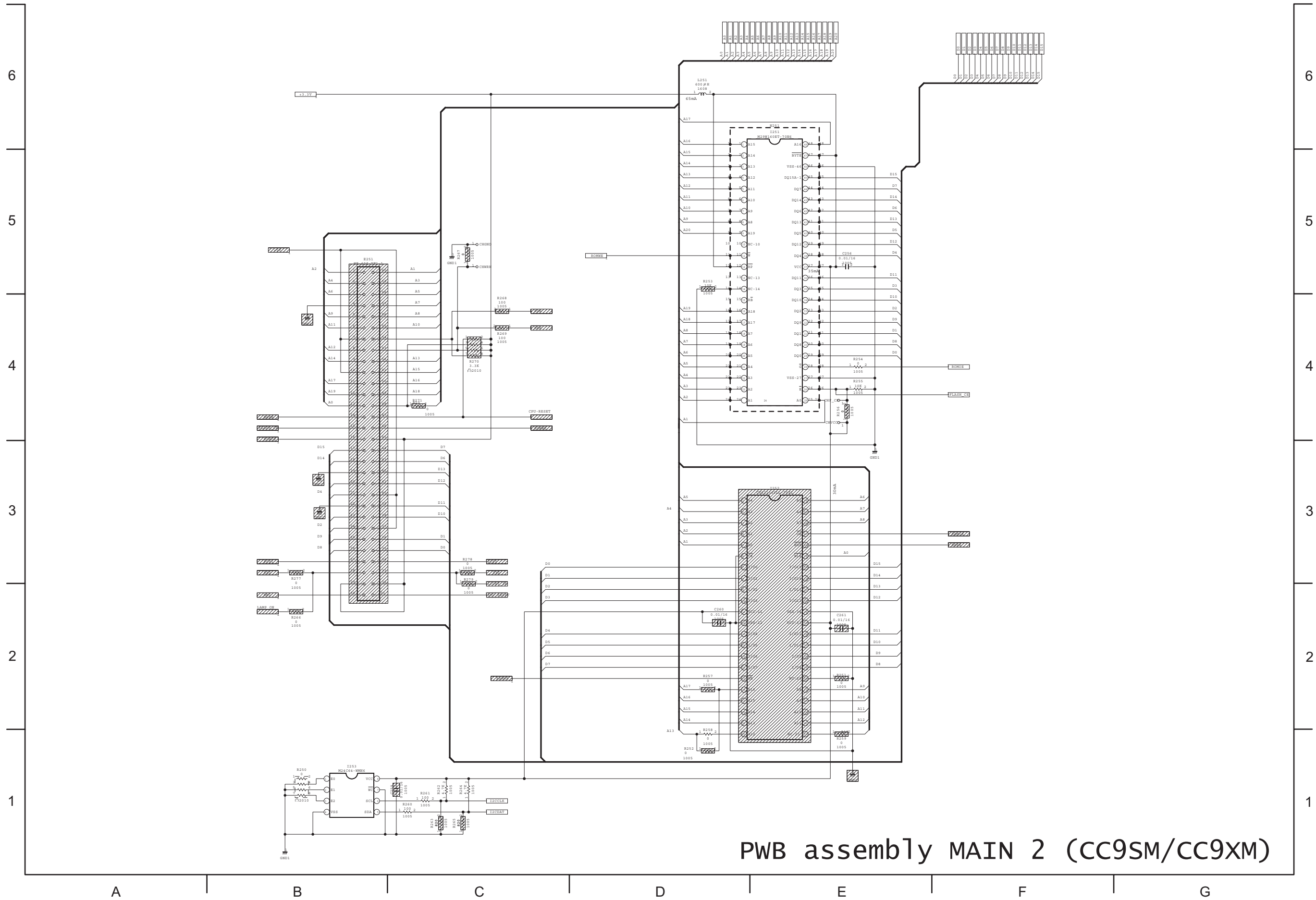

PWB assembly MAIN 2 (CC9SM/CC9XM)

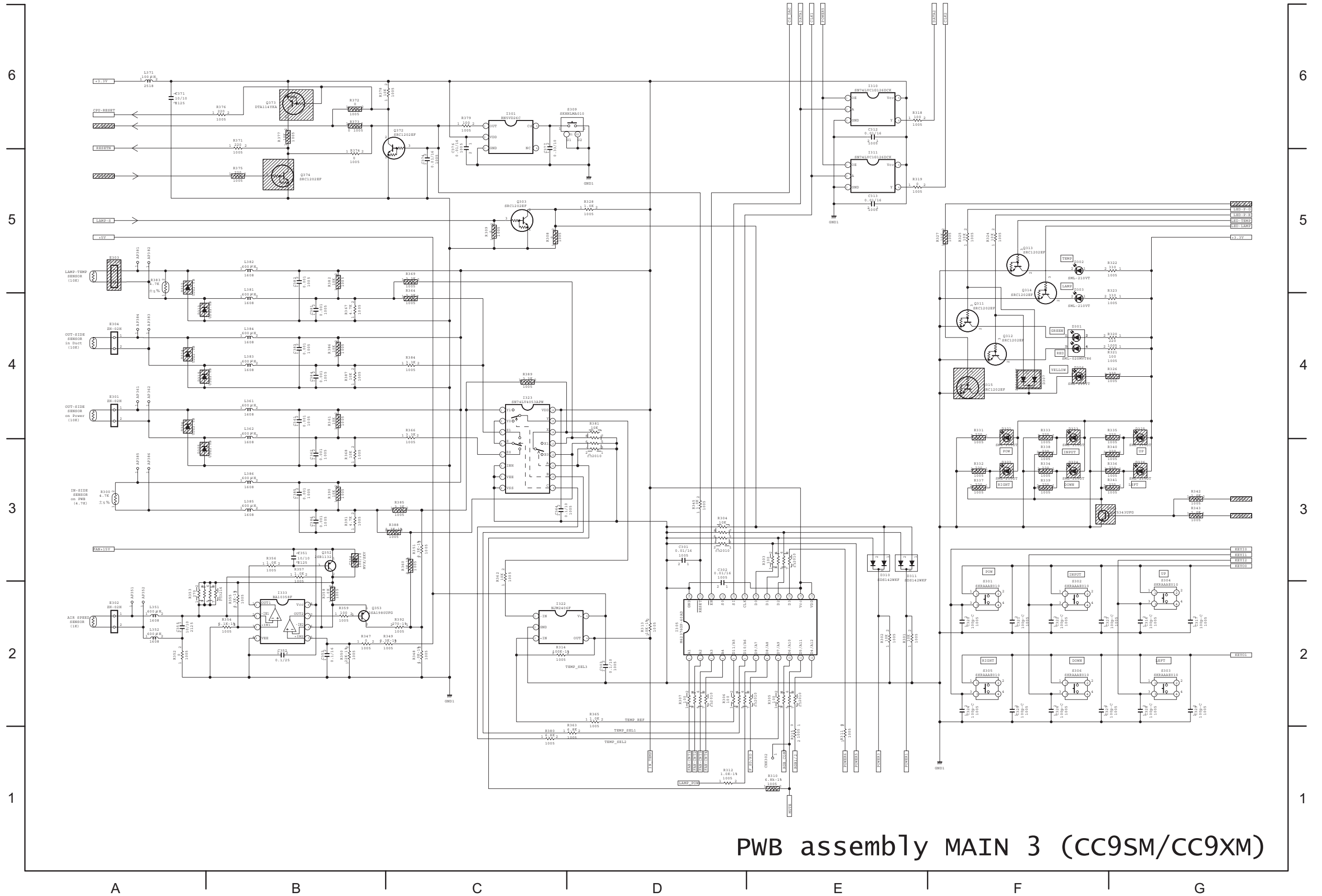

PWB assembly MAIN 3 (CC9SM/CC9XM)

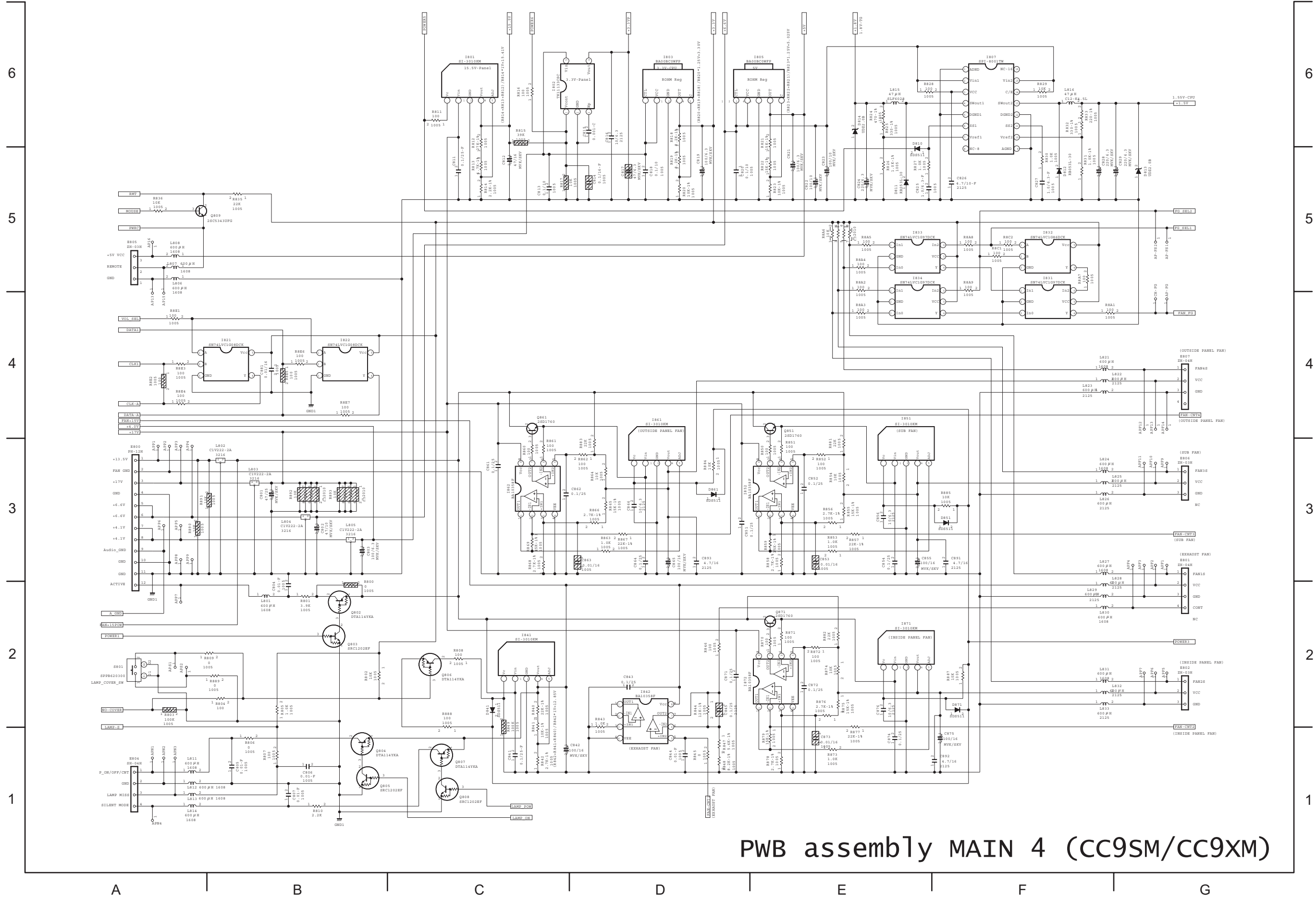

PWB assembly MAIN 4 (CC9SM/CC9XM)

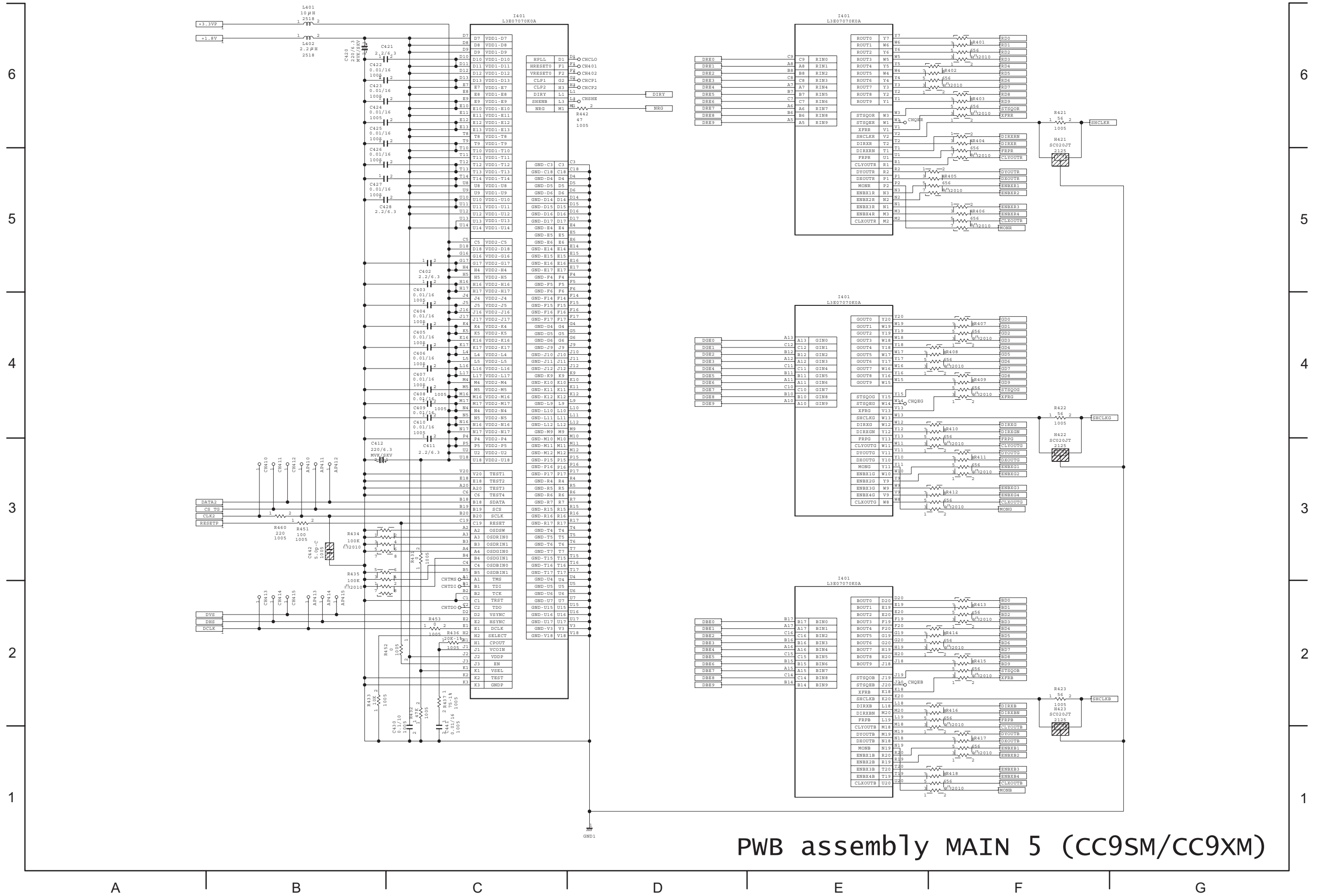

PWB assembly MAIN 5 (CC9SM/CC9XM)

R Panel Part

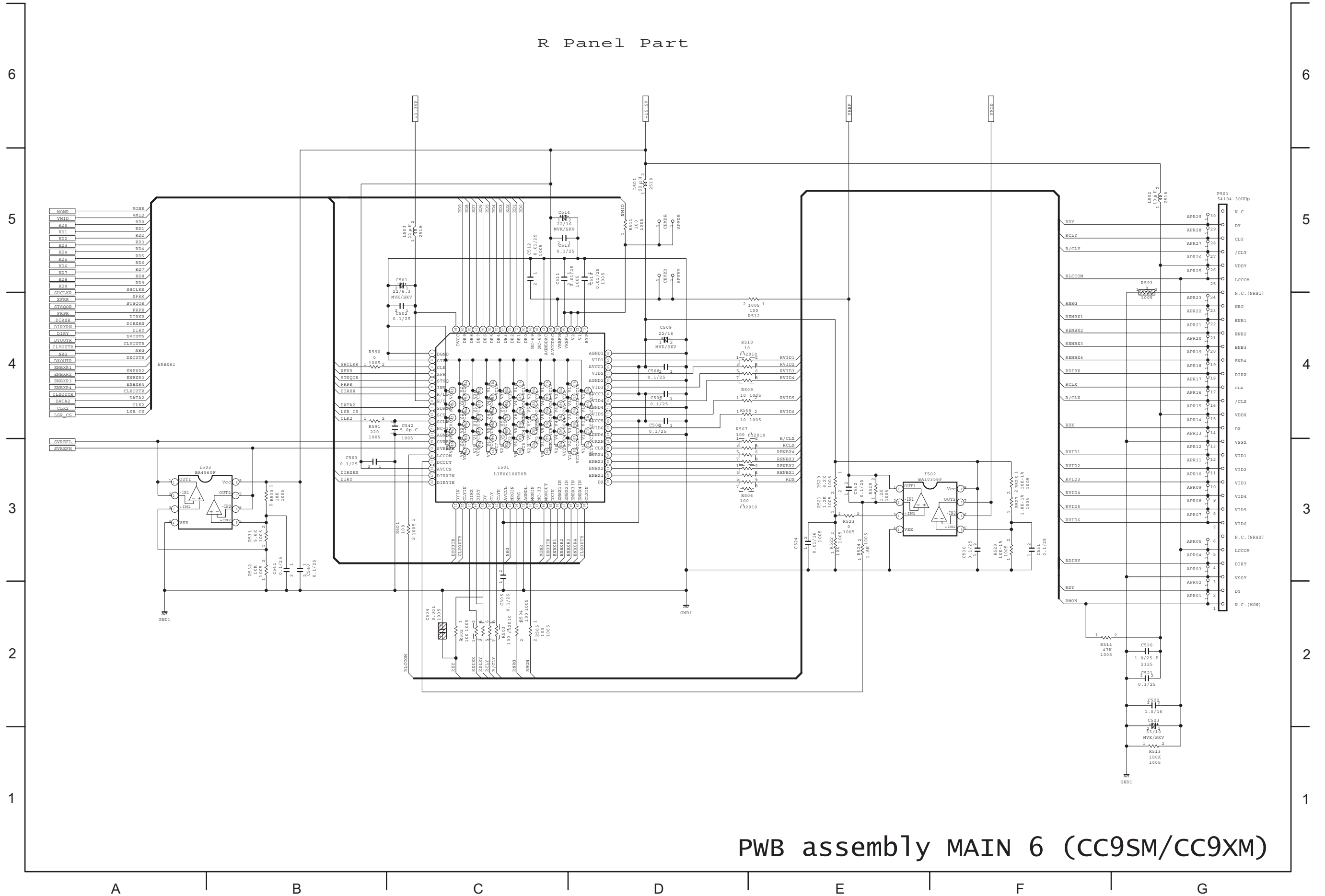

PWB assembly MAIN 6 (CC9SM/CC9XM)

G Panel Part

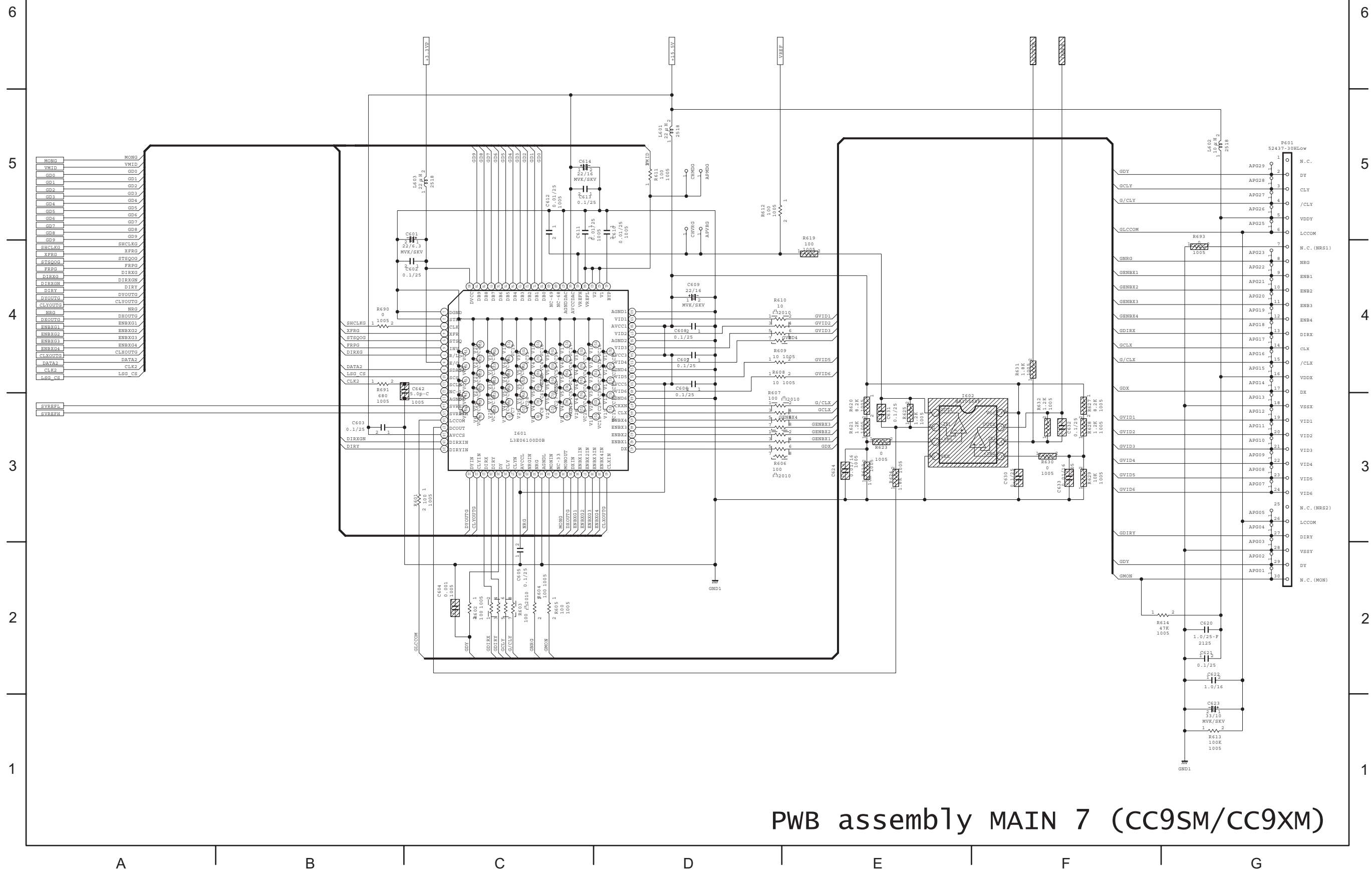

PWB assembly MAIN 7 (CC9SM/CC9XM)

B Panel Part

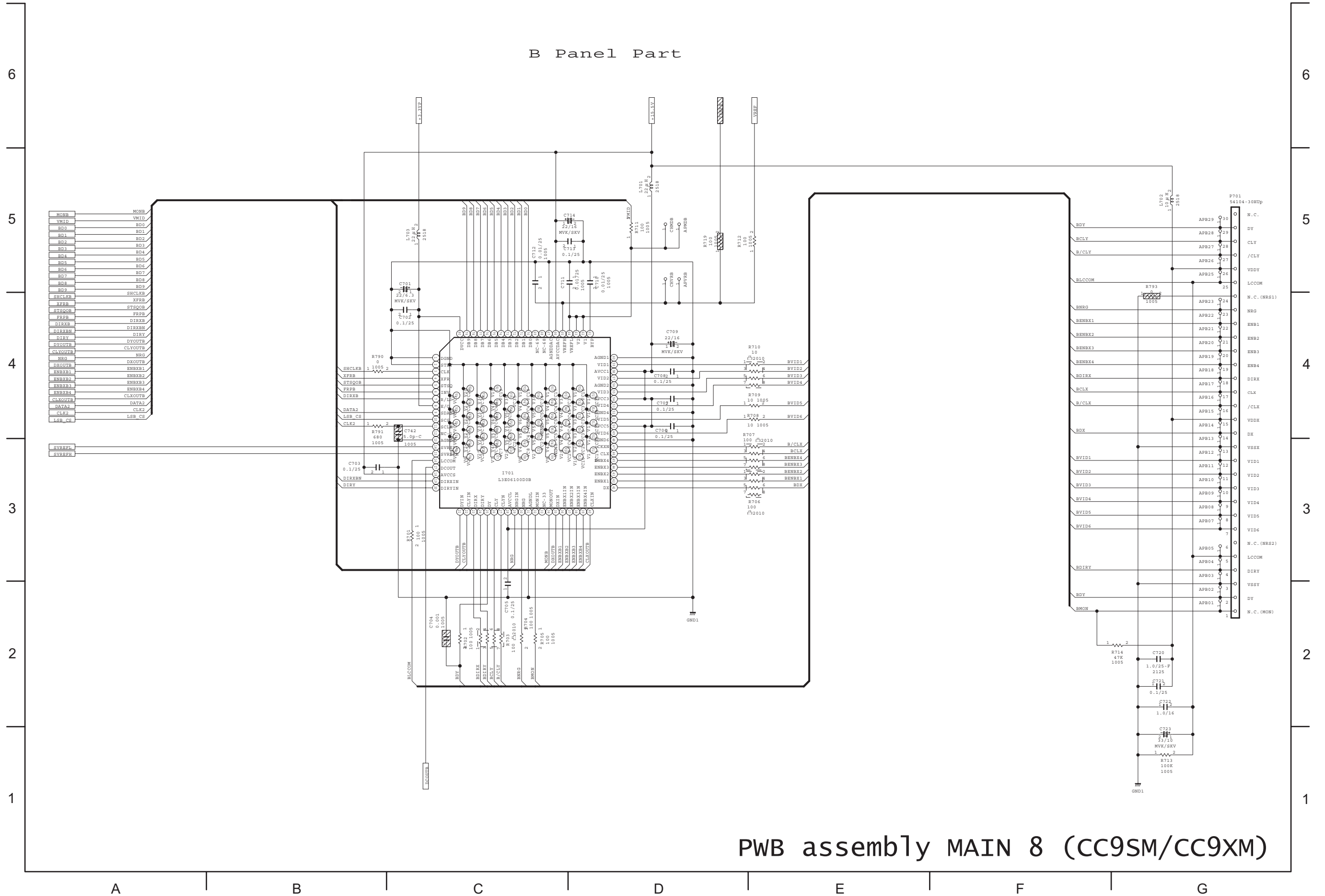

PWB assembly MAIN 8 (CC9SM/CC9XM)

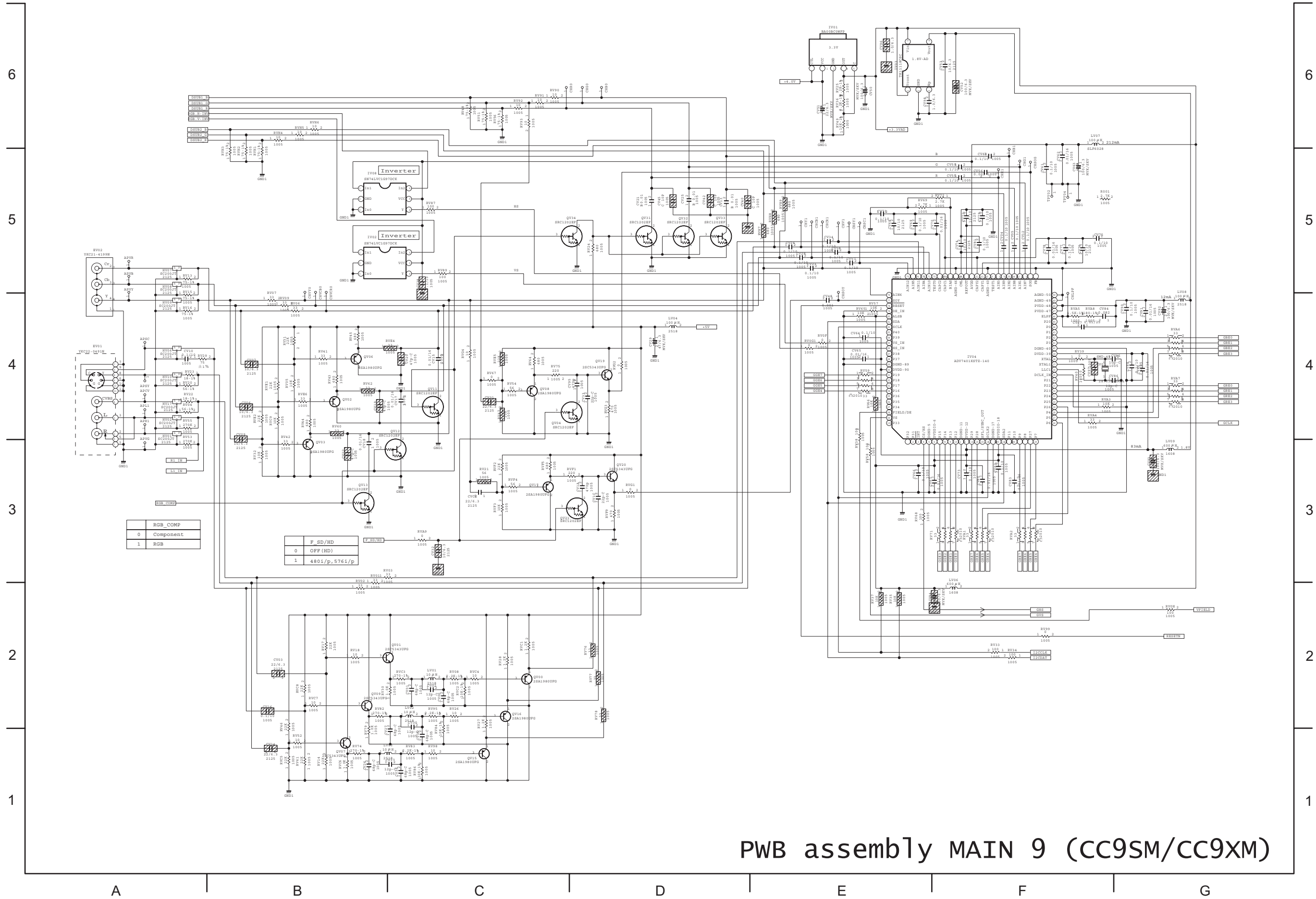

PWB assembly MAIN 9 (CC9SM/CC9XM)

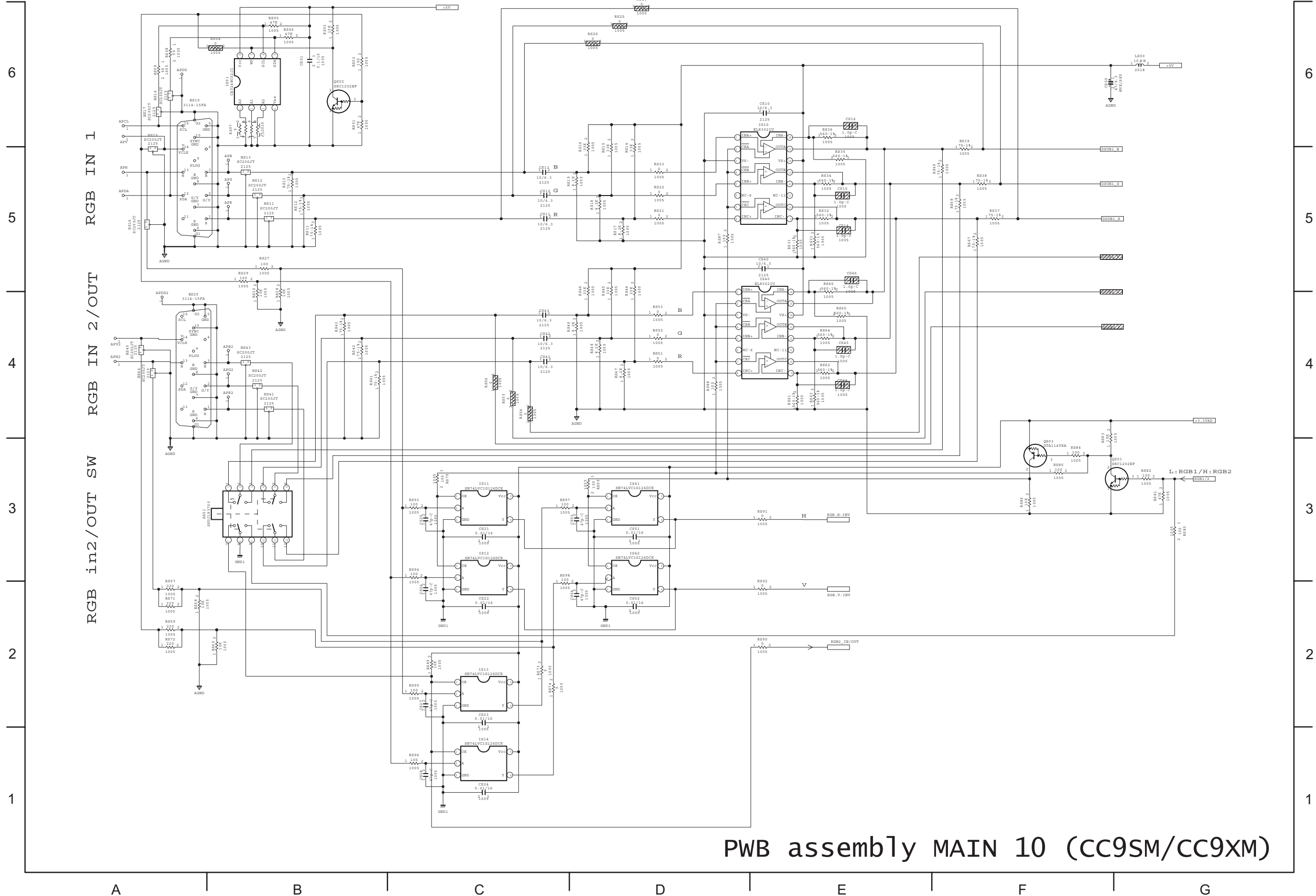

PWB assembly MAIN 10 (CC9SM/CC9XM)

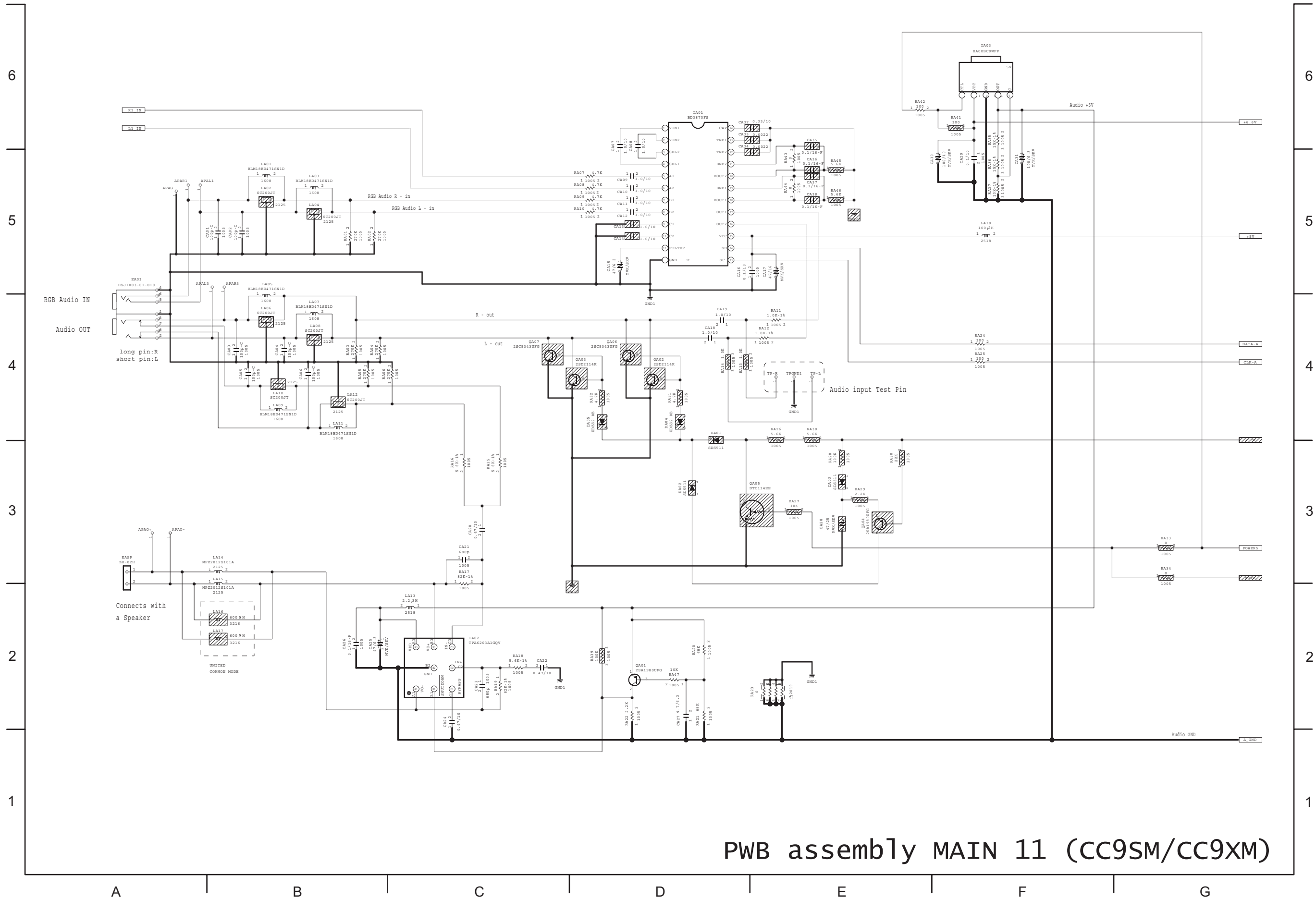

PWB assembly MAIN 11 (CC9SM/CC9XM)

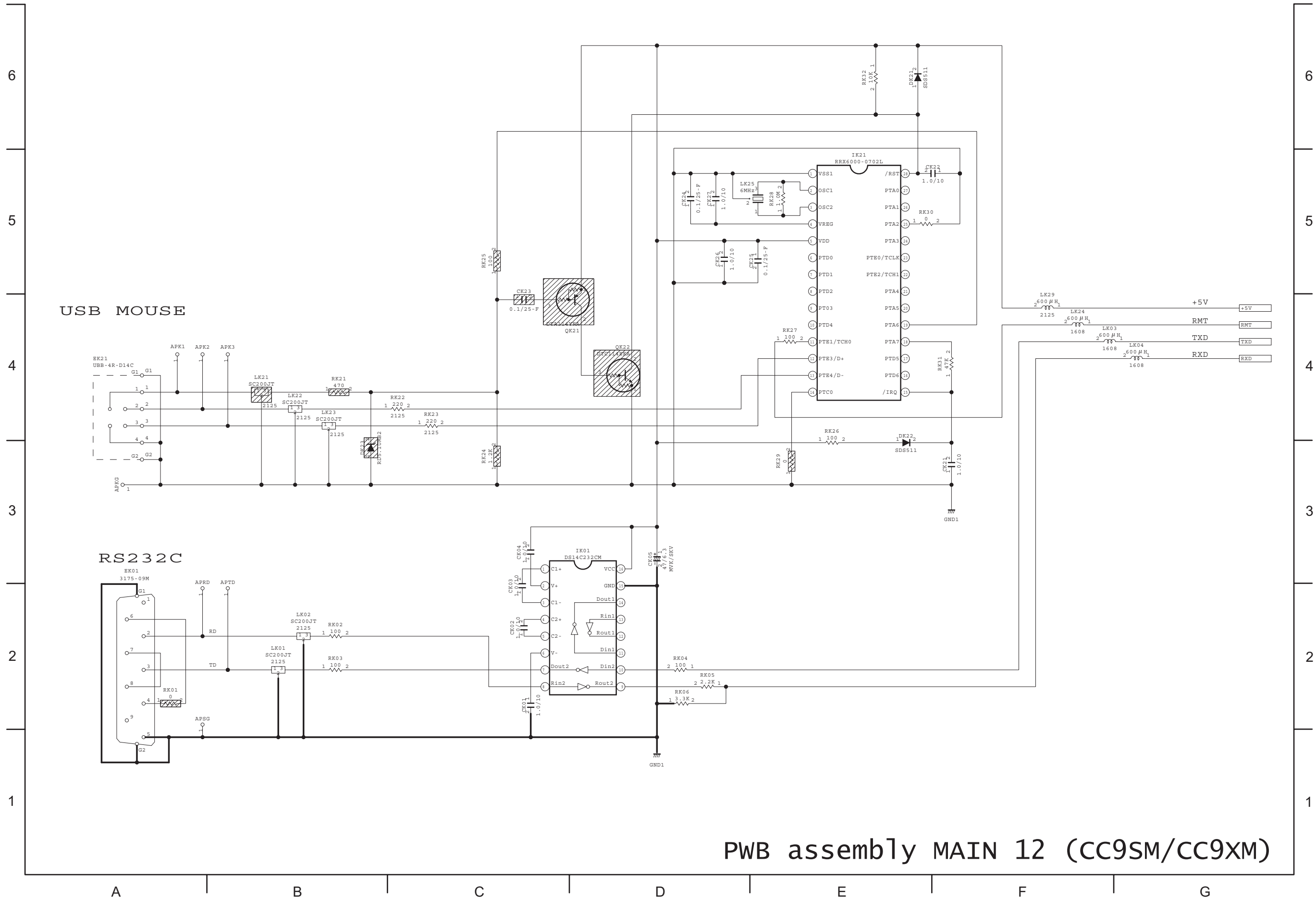

PWB assembly MAIN 12 (CC9SM/CC9XM)

MEMO

Basic circuit diagram list

PWB assembly REMOTE

PWB assembly MAIN 5

POWER UNIT BALLAST 1

PWB assembly MAIN 6

POWER UNIT BALLAST 2

PWB assembly MAIN 7

POWER UNIT CIRCUIT

PWB assembly MAIN 8

PWB assembly MAIN 1

PWB assembly MAIN 9

PWB assembly MAIN 2

PWB assembly MAIN 10

PWB assembly MAIN 3

PWB assembly MAIN 11

PWB assembly MAIN 4

PWB assembly MAIN 12

HITACHI

Hitachi, Ltd. Tokyo, Japan
International Sales Division
THE HITACHI ATAGO BUILDING,
No. 15-12 Nishi Shinbashi, 2 - Chome,
Minato - Ku, Tokyo 105-8430, Japan.
Tel: 03 35022111

HITACHI EUROPE LTD,

Whitebrook Park
Lower Cookham Road
Maidenhead
Berkshire
SL6 8YA

UNITED KINGDOM

Tel: 01628 643000
Fax: 01628 643400
Email: consumer-service@hitachi-eu.com

HITACHI EUROPE S.A.

364 Kifissias Ave. & 1, Delfon Str.
152 33 Chalandri
Athens

GREECE

Tel: 1-6837200
Fax: 1-6835964
Email: service.hellas@hitachi-eu.com

HITACHI EUROPE GmbH

Munich Office
Dornacher Strasse 3
D-85622 Feldkirchen bei München

GERMANY

Tel: +49-89-991 80-0
Fax: +49-89-991 80-224
Hotline: +49-180-551 25 51 (12ct/min)
Email: HSE-DUS.service@hitachi-eu.com

HITACHI EUROPE S.A.

Gran Via Carlos III, 86, planta 5
Edificios Trade - Torre Este
08028 Barcelona

SPAIN

Tel: +34 93 409 2550
Fax: +34 93 491 3513
Email: atencion.cliente@hitachi-eu.com

HITACHI EUROPE srl

Via Tommaso Gulli N.39, 20147
Milano, Italia

ITALY

Tel: +39 02 487861
Tel: +39 02 38073415 Servizio Clienti
Fax: +39 02 48786381/2
Email: customerservice.italy@hitachi-eu.com

HITACHI Europe AB

Box 77 S-164 94 Kista

SWEDEN

Tel: +46 (0) 8 562 711 00
Fax: +46 (0) 8 562 711 13
Email: csgswe@hitachi-eu.com

HITACHI EUROPE S.A.S

Lyon Office
B.P. 45, 69671 BRON CEDEX

FRANCE

Tel: +33 04 72 14 29 70
Fax: +33 04 72 14 29 99
Email: france.consommateur@hitachi-eu.com

HITACHI EUROPE LTD (Norway) AB

STRANDVEIEN 18

1366 Lysaker

NORWAY

Tel: 67 5190 30
Fax: 67 5190 32
Email: csgnor@hitachi-eu.com

HITACH EUROPE AB

Egebækgård
Egebækvej 98
DK-2850 Nærum

DENMARK

Tel: +45 43 43 6050
Fax: +45 43 60 51
Email: csgnor@hitachi-eu.com

HITACHI EUROPE AB

Neopoli / Niemenkatu 73
FIN-15140 Lahti

FINLAND

Tel : +358 3 8858 271
Fax: +358 3 8858 272
Email: csgnor@hitachi-eu.com

Hitachi Europe Ltd

Bergensesteenweg 421
1600 Sint-Pieters-Leeuw

BELGIUM

Tel: +32 2 363 99 01
Fax: +32 2 363 99 00
Email: sofie.van.bom@hitachi-eu.com

HITACHI EUROPE LTD

Na Sychrove 975/8
101 27 Praha 10 - Bohdalec

CZECH REPUBLIC

Tel: +420 267 212 383
Fax: +420 267 212 385
Email: csgnor@hitachi-eu.com

www.hitachidigitalmedia.com

Free Manuals Download Website

<http://myh66.com>

<http://usermanuals.us>

<http://www.somanuals.com>

<http://www.4manuals.cc>

<http://www.manual-lib.com>

<http://www.404manual.com>

<http://www.luxmanual.com>

<http://aubethermostatmanual.com>

Golf course search by state

<http://golfingnear.com>

Email search by domain

<http://emailbydomain.com>

Auto manuals search

<http://auto.somanuals.com>

TV manuals search

<http://tv.somanuals.com>