

ACCESSORY SOCKET

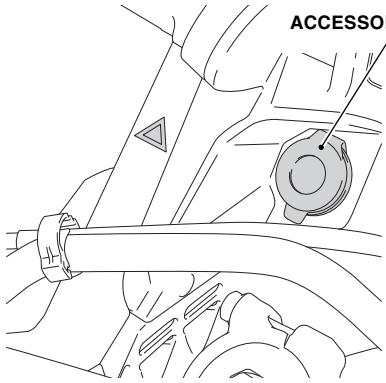

ACCESSORY SOCKET

- The maximum power rating of connected accessories is 24W (12V, 2A).
- Use accessories with the engine running to avoid discharging the battery.
- Do not use a cigarette lighter, as this can cause a malfunction.
- Cover the socket with the cap when the accessory socket is not used to prevent entry of foreign objects.
- Carefully secure any connected devices, as vibrations may cause them to shift unexpectedly.
- Make sure that the device cable connected to the accessory socket does not disturb the steering operation or riding. Make sure the cable is not pinched during steering operation.
- Use a 7.5A fuse for replacement of the fuse in the accessory harness. Do not use any other fuse for replacement.

<INSIDE OF THE LEFT MIDDLE COWL>

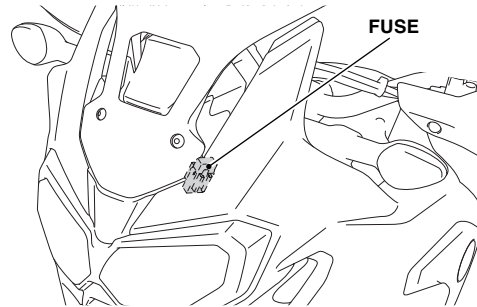

FUSE

LIGHT BAR

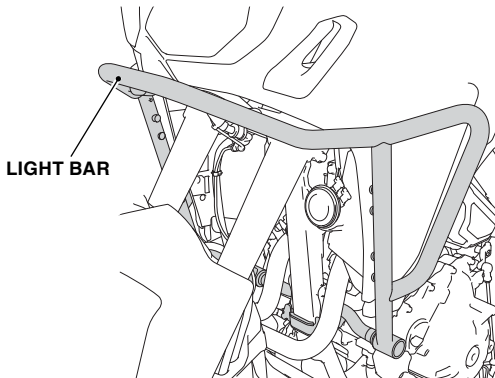

LIGHT BAR

- Do not attempt to move the motorcycle by holding front light bar and as it may damage the motorcycle or light bar.
- When this accessory becomes dirty, rinse it thoroughly with cool water to remove loose dirt, then wipe with a clean cloth or sponge. Do not use a brush to clean this accessory as it may scratch the surface.
- Never use organic solvents such as gasoline, thinner and benzene to clean this accessory. Also do not use acid or alkaline cleaners to clean this accessory. Wipe up spilled brake or battery fluid at once as they may damage the surface.

CENTERSTAND

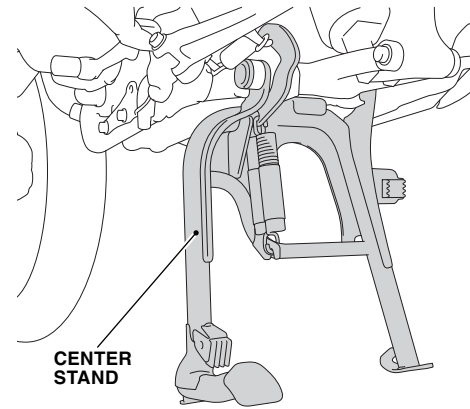

CENTER STAND

- Before starting your motorcycle, check that the sidestand and the centerstand are fully retracted.
- Always choose flat ground when setting the centerstand.
- Always use the parking brake when parking the CRF1000LD and using the centerstand.

HOW TO USE THE CENTERSTAND

1. Park safely on level ground and stop the engine.
2. Setting the center stand.
 - Stand on the left side of the motorcycle and lower the centerstand with your right foot. Hold the left handgrip with your left hand and the rear carrier with your right hand. Press down on the tip of the stand with your right foot and, simultaneously, pull up and back on the rear carrier.

TALL WINDSCREEN

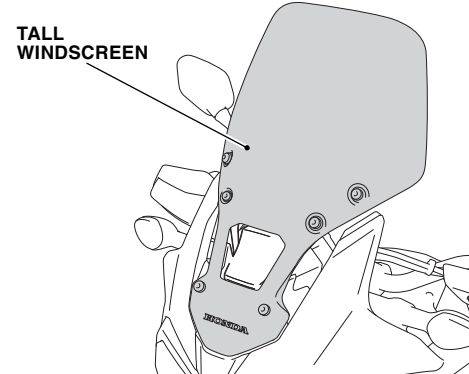

TALL WINDSCREEN

- Reduce speed when riding in strong wind.
- Replace this accessory with a new one if it is damaged or discolored excessively.
- When this accessory becomes dirty, rinse it thoroughly with cool water to remove loose dirt, then wipe with a clean cloth or sponge. Do not use a brush to clean this accessory as it may scratch the surface.
- Never use organic solvents such as gasoline, thinner and benzene to clean this accessory. Also do not use acid or alkaline cleaners to clean this accessory. Wipe up spilled brake or battery fluid at once as they may damage the surface.
- If the motorcycle is left covered for an extended period of time, park in the shade. Parking a covered motorcycle in direct sunlight can cause the windscreen to deform due to heat buildup under the cover.
- Handle this accessory with care. It can be damaged when it is bent excessively or is subject to strong shock or impact.
- Bear in mind that strong wind can cause the motorcycle to topple over. Select a firm, level surface when you park the motorcycle.

HEATED GRIPS

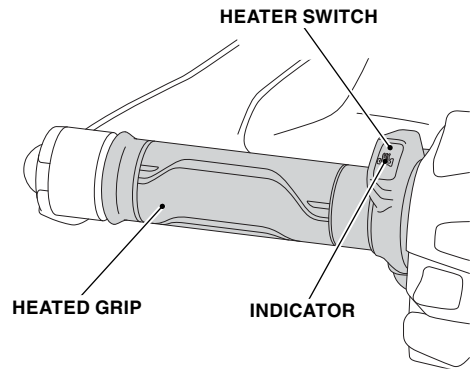

- Wear gloves to protect your hands from the heated grips.
- Do not use the heated grips with the engine at idle for a long time. It may result in a low (or dead) battery.
- Adjust the temperature by repeatedly pressing the switch.
The temperature can be set to five levels.
- The heated grips maintain the selected level when the ignition switch is turned off.
- The heater level is not changed if the ignition switch is turned to the OFF position within 5 seconds of changing the heater level.
- Do not leave the heated grips in the high position for a long time on a warm day.

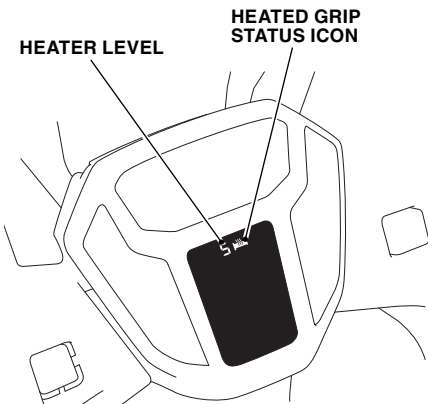

INDICATOR

- Displayed when the heated grips are on.
- The selected heater level is indicated by the number of times the indicator blinks when the heater is turned on and the heater level is changed. For example, If you select heater level 5, the indicator blinks 5 times and repeats it 7 times.

HEATER LEVEL

- The selected heater level is indicated for a few seconds when the heater switch is operated.

HEATED GRIP STATUS ICON

- Displayed when the heated grips are on.
- If the heated grip system has an error, the grip heater status icon will blink. If the "E1", "E2" or "E3" blinking does not go off, see a Honda dealer as soon as possible.

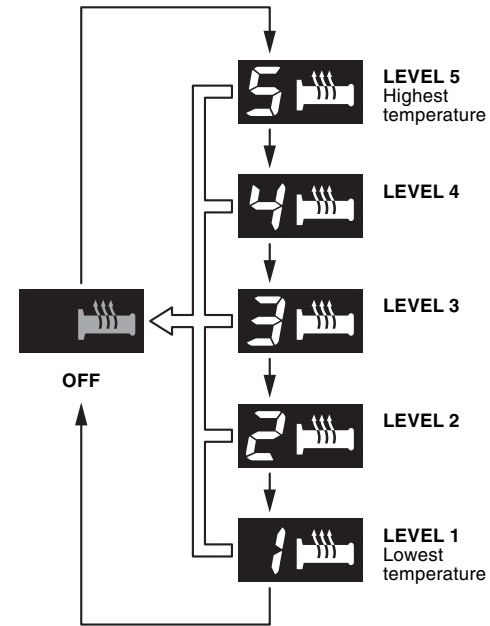

← Press the heater switch.

← Press and hold the heater switch.

HOW TO USE THE HEATED GRIPS

1. Start the engine.
2. Press the heater switch. The heated grips are on.
3. Select the heater level by pressing the heater switch.
 - The clock on the display automatically switches to indicate the heater level. The indicator will return to the ordinary mode after blinking for about 5 seconds.
4. To turn off the heater, press the heater switch until the status icon on the display disappears.
 - To turn off, press and hold the heater switch.

CRF1000L/LD

Genuine Accessory User's Guide

TOP CASE

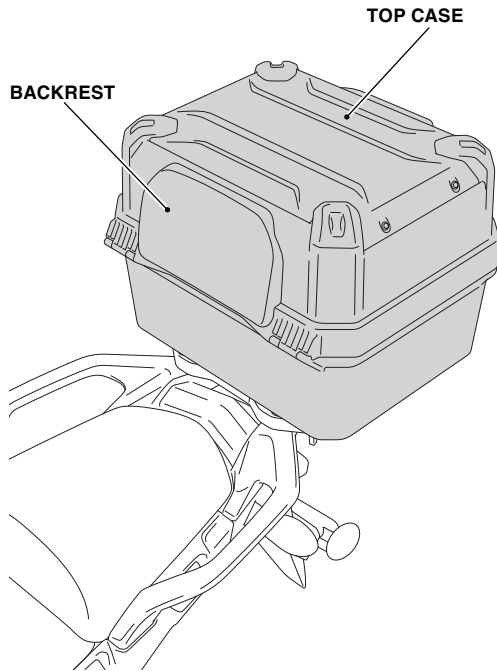

- The weight of the cargo must not exceed the following maximum weight capacity:
13.2 lb (6.0 kg)
- The mounting and loading of a top case on a motorcycle, particularly when placed above the original center of gravity, can negatively affect handling and stability. When adding and using the top case, do not exceed allowable cargo weight recommendations and proceed carefully until you understand the effect on your motorcycle's handling and stability.
- Be sure that the top case is installed securely before riding.
- Before riding, confirm the lid is closed.
- The top case is not perfectly watertight, and water may enter when washing the motorcycle, when it rains, etc.
- To prevent burns, allow the engine, exhaust system, radiator, etc., to cool before installing and removing the accessory.
- Do not store valuables or fragile articles in the top case.
- Don't place a heavy object on the opened lid or apply excessive force to the top of the opened lid.
- Open and close the lid gently.
- If the top case gets dirty, lightly brush and clean it with a sponge or a shop towel moistened with a neutral detergent, remove the detergent with clean water, and then wipe it dry with a clean sponge or shop towel.
- Never use organic solvents such as gasoline, thinner and benzine to clean this accessory. Also do not use acid or alkaline cleaners to clean this accessory.

Wipe up spilled brake or battery fluid at once as they may damage the surface.

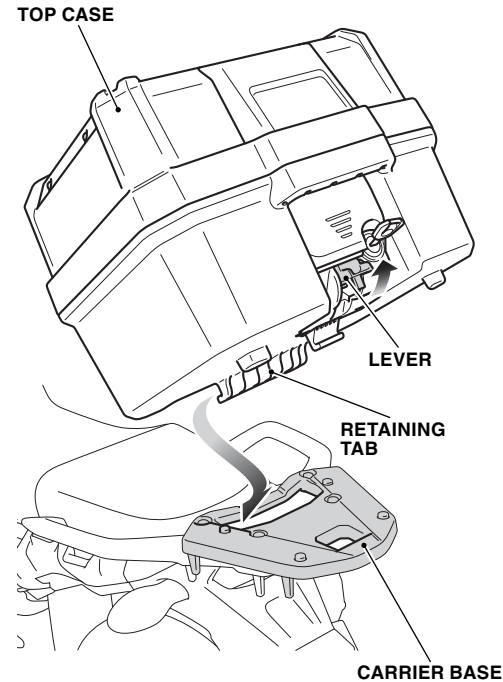

HOW TO INSTALL THE TOP CASE

1. Release the lock by turning the key clockwise.

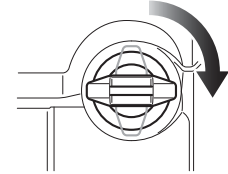

2. Install the retaining tab of the top case into the carrier base.

- **Install the top case with this lever raised.**

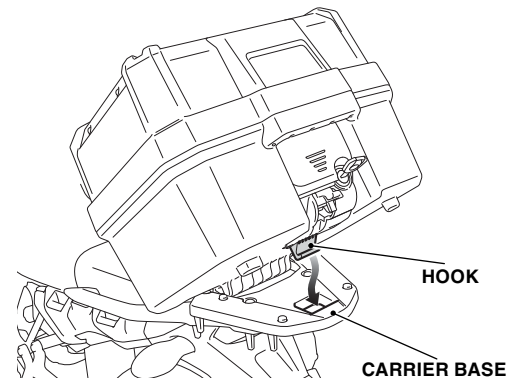

3. Position the hook with the hole of the carrier base as shown.

4. Secure the hook by pressing the lever down.

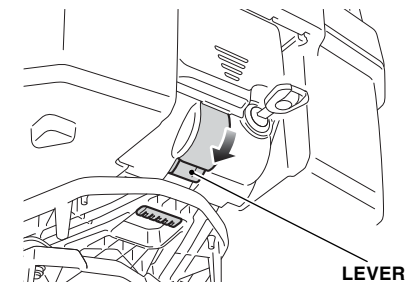

CRF1000L/LD

Genuine Accessory User's Guide

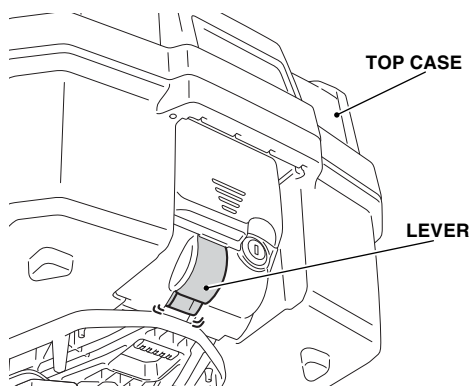

5. Lock the top case by turning the key counterclockwise as shown.

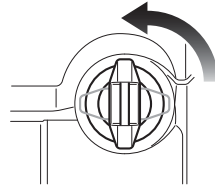

6. Remove the key, check that the lever will not lift and the top case is installed securely.
 - The top case can come off while riding unless it is mounted securely.

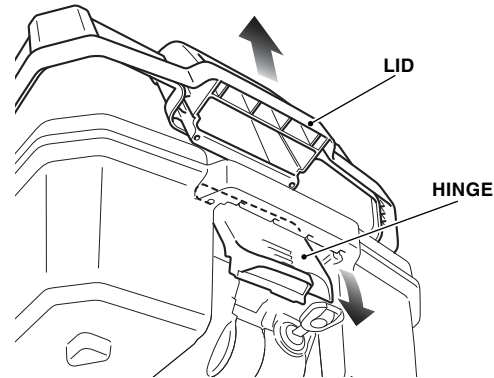

3. Raise the upper part of hinge, move the hinge down as shown and open the lid.

HOW TO REMOVE THE TOP CASE

1. Remove the top case in the reverse order of installation.

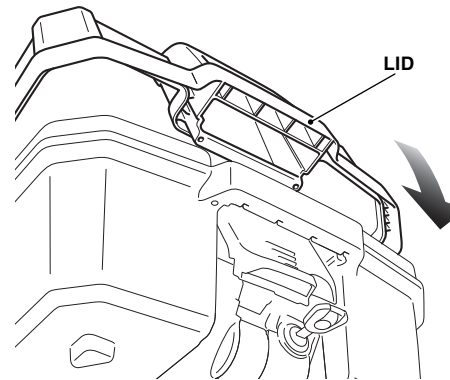

HOW TO CLOSE THE TOP CASE

1. Confirm that the key position is as shown.

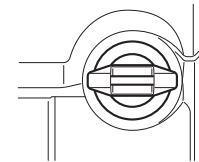

2. Close the lid.

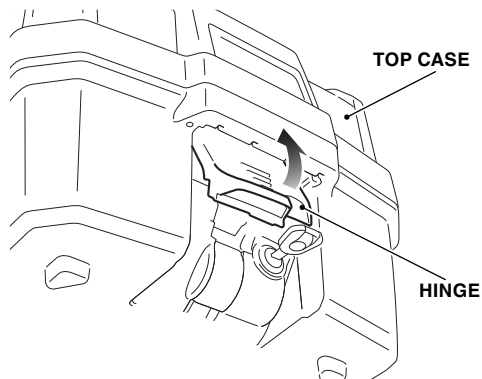

HOW TO OPEN THE TOP CASE

1. Release the lock by turning the key clockwise.

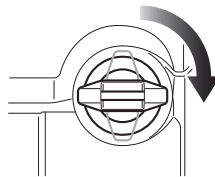

2. Pull the hinge up.

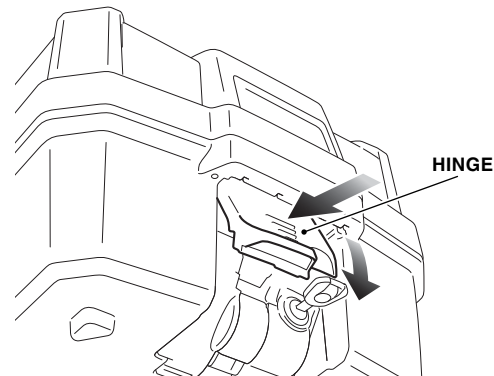

3. Holding the upper part of the hinge, push the hinge down.
4. Lock the top case by turning the key counterclockwise as shown.

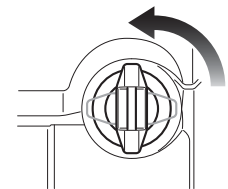

5. Remove the key.
 - Make sure the lid is locked down securely.

PANNIERS

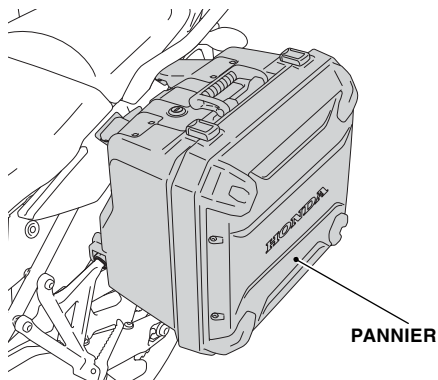

- The weight of the cargo must not exceed the following maximum weight capacity:
Each pannier 11.0 lb (5.0 kg)
- Load weight equally on both sides to minimize imbalance. The mounting and loading of panniers, particularly when placed above the original center of gravity, can negatively affect handling and stability. When adding and using panniers, do not exceed allowable cargo weight recommendations and proceed carefully until you understand the effect on your motorcycle's handling and stability.
- Do not store valuables or fragile articles in the panniers.
- Be sure that the panniers are installed securely before riding.
- Before riding, confirm the lids are closed.
- To prevent burns, allow the engine, exhaust system, radiator, etc., to cool before installing and removing this accessory.
- The pannier can become hot while the engine is running and after it has been stopped (after riding etc.).
Especially the lower part of the pannier on the right side, close to the muffler, and thus may become very hot. For that reason it should not be touched for some time.
- The panniers are not perfectly watertight, and water may enter when washing the motorcycle or when it rains.
- Always install panniers on both the left and the right side.
- Don't place a heavy object on the opened lid or apply an excessive force to the top of opened lid.
- Open and close the lid gently.
- If the pannier gets dirty, lightly brush and clean it with a sponge or a shop towel moistened with a neutral detergent, remove the detergent with clean water, and then wipe them dry with a clean sponge or shop towel.
- Never use organic solvents such as gasoline, thinner and benzene to clean this accessory. Also do not use acid or alkaline cleaners to clean this accessory.
Wipe up spilled brake or battery fluid at once as they may damage the surface.

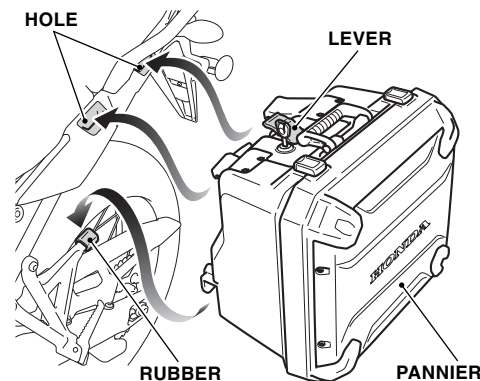

HOW TO INSTALL THE PANNIERS

1. Release the lock by turning the key clockwise.

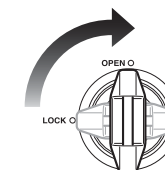

2. Install the pannier.
 - Install the pannier with this lever raised.
 - First engage at the rubber and then install at the two holes.

3. Lower the lever as shown.

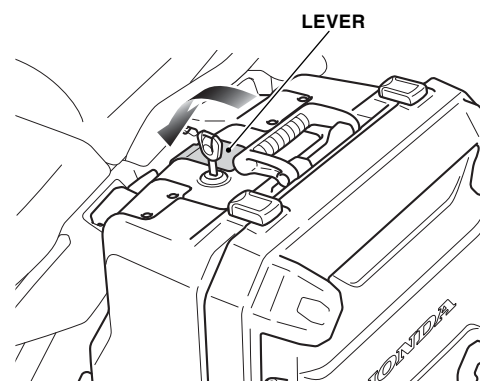

4. Lock the pannier by turning the key counter-clockwise as shown.

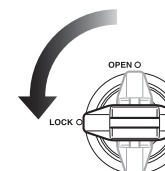

5. Remove the key. Be sure that the lever cannot be released and the pannier is installed securely.
 - The pannier can come off while riding unless it is mounted securely.

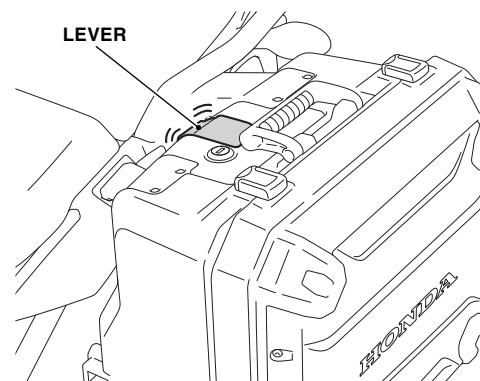

CRF1000L/LD

Genuine Accessory User's Guide

HOW TO REMOVE THE PANNIERS

1. Remove the panniers in the reverse order of installation.

HOW TO CLOSE THE PANNIERS

1. Close the panniers in reverse order of opening.

HOW TO OPEN THE PANNIERS

1. Release the lock by turning the key clockwise.

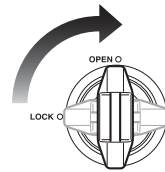
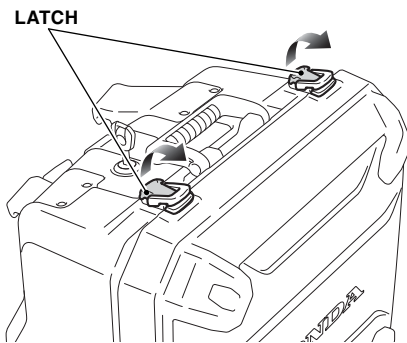

2. Open the latch.

3. Open the lid.

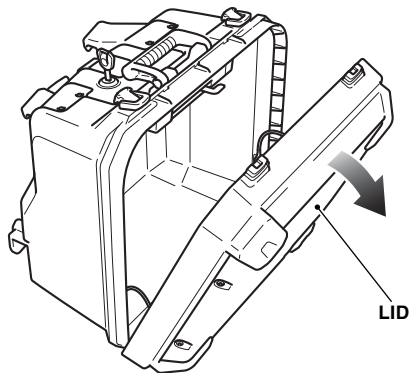

HOW TO INSTALL THE INNER BAG

1. Install the separately sold inner bag.

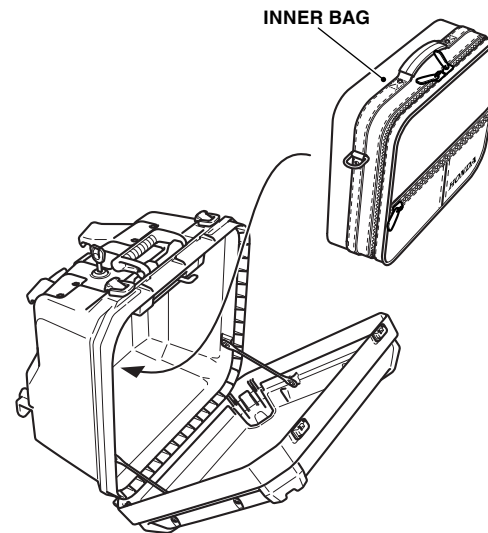

Free Manuals Download Website

<http://myh66.com>

<http://usermanuals.us>

<http://www.somanuals.com>

<http://www.4manuals.cc>

<http://www.manual-lib.com>

<http://www.404manual.com>

<http://www.luxmanual.com>

<http://aubethermostatmanual.com>

Golf course search by state

<http://golfingnear.com>

Email search by domain

<http://emailbydomain.com>

Auto manuals search

<http://auto.somanuals.com>

TV manuals search

<http://tv.somanuals.com>