

All information in this publication is based on the latest product information available at the time of approval for printing. Honda Motor Co., Ltd. reserves the right to make changes at any time without notice and without incurring any obligation.

No part of this publication may be reproduced without written permission.

TO THE NEW OWNER

By selecting a Honda motocross CRF450R as your new motorcycle, you have placed yourself in a distinguished family of motorcycle owners and riders.

▲ WARNING

- ***The CRF is a high performance racing motorcycle utilizing the latest motocross technology. This motorcycle is intended for competition use by experienced riders only.***

This new motocross model was designed to be as competitive as possible. But motocross is a physically demanding sport that requires more than just a fine motorcycle. To do well, you must be in excellent physical condition and be a skillful rider. For the best possible results, work diligently on your physical conditioning and practice frequently.

The purpose of this Owner's Manual is to help ensure that you obtain the greatest possible satisfaction from your new CRF motocrosser – satisfaction with the performance of the motorcycle, and through success in competition.

The Service Manual for your CRF is available from your authorized Honda dealer. It is the same manual your dealer uses. If you plan to do any service on your CRF beyond the standard maintenance procedures included in this Owner's Manual, you will find the Service Manual an effective and worthwhile tool. If your dealer does not have the Service Manual for your particular year and model in stock, he can order it.

Read this WARNING LABEL before you ride.

IMPORTANT INFORMATION

OPERATOR ONLY. NO PASSENGERS. THIS HONDA MOTORCYCLE IS SOLD AS IS WITHOUT WARRANTY, AND THE ENTIRE RISK AS TO QUALITY AND PERFORMANCE IS WITH THE BUYER. READ OWNER'S MANUAL.

THIS VEHICLE IS DESIGNED AND MANUFACTURED FOR COMPETITION USE ONLY. IT DOES NOT CONFORM TO FEDERAL MOTOR VEHICLE SAFETY STANDARDS AND OPERATION ON PUBLIC STREETS, ROADS, OR HIGHWAYS IS ILLEGAL. STATE LAWS PROHIBIT OPERATION OF THIS VEHICLE EXCEPT IN AN ORGANIZED RACING OR COMPETITIVE EVENT UPON A CLOSED COURSE WHICH IS CONDUCTED UNDER THE AUSPICES OF A RECOGNIZED SANCTIONING BODY OR BY PERMIT ISSUED BY THE LOCAL GOVERNMENTAL AUTHORITY HAVING JURISDICTION. FIRST DETERMINE THAT OPERATION IS LEGAL.

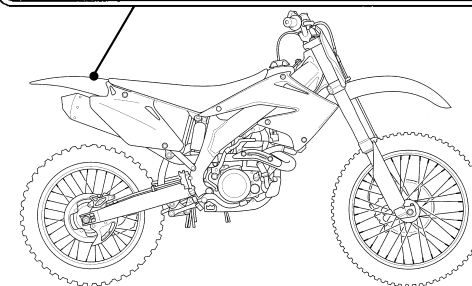

PROTECTIVE APPAREL

1. Most motorcycle accident fatalities are due to head injuries: **ALWAYS** wear an approved motorcycle helmet. You should also wear a face shield or goggles, boots, gloves, and protective clothing.
2. The exhaust system becomes very hot during operation, and it remains hot after operation. Never touch any part of the hot exhaust system. Wear clothing that fully covers your legs.
3. Do not wear loose clothing which could catch on the control levers, kickstarter, footpegs, drive chain, or wheels.

MODIFICATIONS

▲ WARNING

- ***Modification of the motorcycle, or removal of original equipment may render the vehicle unsafe or illegal. Obey all federal, state, and local equipment regulations.***

CONTENTS

| | | | | | |
|---|----|--|-----|---------------------------------|-----|
| 1. OPERATING INSTRUCTIONS | 2 | • Crankcase Breather | 27 | 14. STORAGE | 101 |
| Fuel | 2 | • Air Cleaner | 27 | • To Prepare The Motorcycle For | |
| Basic Operation | 2 | • Clutch | 28 | Storage | 101 |
| • Starting The Engine | 2 | • Valve | 30 | • Removal From Storage | 101 |
| • Stopping The Engine | 3 | • Piston/Piston Rings/Piston Pin | 39 | 15. WIRING DIAGRAM | 102 |
| • Break-In Procedure | 3 | • Handlebar And Steering Head | | 16. INDEX | 103 |
| Contotls | 4 | Bearings | 47 | 17. AUTHORIZED MANUALS | 105 |
| Control Adjustment | 5 | • Throttle Grip | 47 | | |
| • Clutch Lever Free Play | 5 | • Fuel Line | 48 | | |
| • Clutch Lever Position | 5 | • Front And Rear Wheels And Tires | 49 | | |
| • Hot Start | 6 | • Front Suspension | 49 | | |
| • Throttle Grip | 6 | • Rear Suspension | 50 | | |
| • Front Brake Lever | 7 | • Brakes | 51 | | |
| • Brake Pedal Height | 7 | • Drive Chain | 52 | | |
| Adjustment For Personal Fit | 8 | • Drive Chain Sliders | 54 | | |
| • Control Positioning | 8 | • Drive Chain Rollers | 54 | | |
| • Handlebar Position, Width & Shape | 8 | • Driven Sprocket | 55 | | |
| • Additional Individualized | | • Exhaust Pipe/Muffler | 55 | | |
| Adjustments | 8 | • Control Cables | 57 | | |
| 2. SPECIFICATIONS | 9 | • Nuts, Bolts, Fasterers | 58 | | |
| 3. OPTIONAL PARTS | 10 | 5. CARBURETOR ADJUSTMENT | 61 | | |
| Optional Parts List | 10 | • Carburetor | 61 | | |
| 4. SERVICE AND MAINTENANCE | 11 | • Tuning For Special Conditions | 70 | | |
| Pre-ride Inspection Check List | 11 | • Spark Plug Coloring Indications | 70 | | |
| Maintenance Schedule | 11 | 6. SUSPENTION ADJUSTMENT | 71 | | |
| General Service Information | 12 | • Race Sag | 71 | | |
| Between Moto/Between Practice And Moto | | • Rear Suspension | 72 | | |
| Maintenance | 12 | • Front Suspension | 74 | | |
| After Race Maintenance | 13 | • Suspension Adjustments Relating To | | | |
| • After Race Lubrication | 13 | Specific Track Conditions | 90 | | |
| • Routine Cleaning | 13 | • Suspension Adjustment Guidelines | 91 | | |
| • Pressurized Spray Washers | 13 | 7. CHASSIS ADJUSTMENTS FOR TRACK | | | |
| • Condensation Control | 13 | CONDITIONS | 94 | | |
| • After Cleaning Lubrication | 13 | • Rear End | 94 | | |
| General Maintenance | 14 | • Fork Height/Angle | 94 | | |
| Maintenance Preparations | 17 | • Wheelbase | 94 | | |
| • Seat | 17 | 8. GEARING SELECTION | 94 | | |
| • Fuel Tank | 17 | 9. TIRE SELECTION | 95 | | |
| • Subframe | 19 | 10. MAINTENANCE, TUNING & RACING | | | |
| Maintenance Procedures | 21 | LOGBOOK | 96 | | |
| • Engine Oil | 21 | 11. SPARE PARTS & EQUIPMENT | 98 | | |
| • Transmission Oil | 23 | 12. TROUBLESHOOTING | 99 | | |
| • Coolant | 24 | • Poor Performance At Low And | | | |
| • Spark Plug | 25 | Unstable Idle Speeds | 99 | | |
| • Ignition | 26 | • Poor Performance At High Speed | 99 | | |
| • Engine Idle Speed | 26 | 13. CLEANING | 100 | | |

1. OPERATING INSTRUCTIONS

FUEL

Fuel tank capacity: 2.0 US gal (7.4 liter, 1.6 Imp gal)

To open the fuel fill cap, pull the breather tube out of the steering stem nut. Then turn the fuel fill cap counterclockwise.

- Use automobile gasoline with a pump octane number of 92 or higher. If “knocking” or “pinging” occurs, try a different brand of gasoline or a higher octane grade.

▲ WARNING

- **Gasoline is extremely flammable and is explosive under certain conditions. Perform this operation in a well-ventilated area with the engine stopped. Do not smoke or allow flames or sparks in the area where gasoline is drained or stored and where the fuel tank is refueled.**

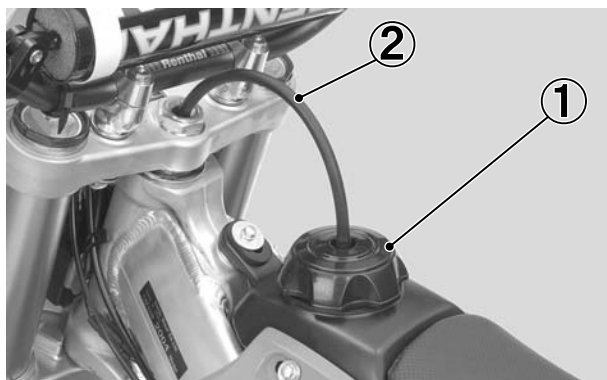

(1) FUEL FILL CAP (2) BREATHER TUBE

BASIC OPERATION

Starting The Engine

▲ WARNING

- **Never run the engine in an enclosed area. The exhaust contains poisonous carbon monoxide gas that can cause loss of consciousness and lead to death.**
- **Attempting to start the engine with the transmission in gear and clutch engaged may result in injury or damage.**

NOTE:

- This motorcycle can be kickstarted with the transmission in gear by disengaging the clutch before operating the kickstarter.

Check the engine oil, transmission oil and coolant levels before starting the engine (page 21, 23, 24).

Cold Engine Starting:

1. Turn the fuel valve ON.
2. Shift the transmission into neutral.
3. If the temperature is 35°C (95°F) or below, pull the choke knob fully out.
4. If the temperature is below 0°C (32°F), open the throttle two or three times. (The engine requires a richer mixture for starting in cold weather. When the throttle is so opened, the accelerator pump will feed extra fuel to the cylinder, thereby facilitating starting in cold weather.)
5. With the throttle closed, operate the kickstarter starting from the top of the kickstarter stroke, kick through to the bottom with a rapid, continuous motion. (Do not open the throttle, As the carburetor is equipped with an accelerator pump, excessive fuel will be charged into the engine, and the spark plug will be fouled if the throttle is opened and closed repeatedly. Excessive fuel in the engine makes kick-starting difficult.)
6. About a minute after the engine starts, push the choke knob back all the way to fully OFF. If idling is unstable, open the throttle slightly.

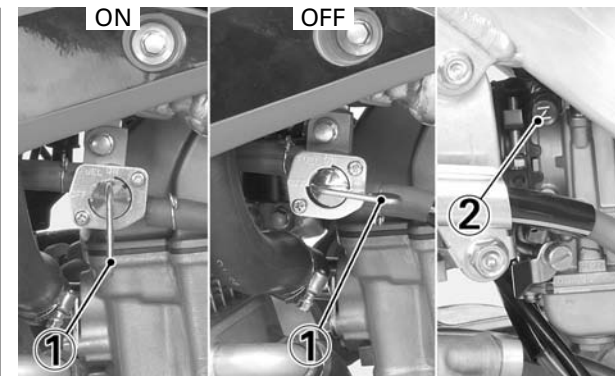

(1) FUEL VALVE

(2) CHOKE KNOB

Warm Engine Starting:

1. Turn the fuel valve ON.
2. Shift the transmission into neutral.
3. Pull the hot start lever and kick-start the engine. (Do not open the throttle.)
4. As soon as the engine starts, release the hot start lever.

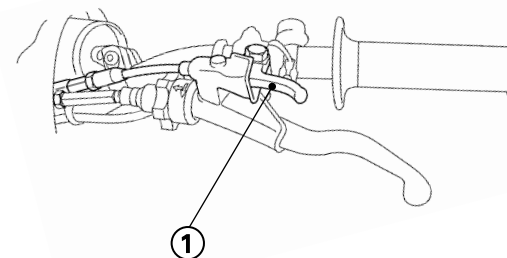

(1) HOT START LEVER

Starting the engine after a stall during riding or after a fall:

1. Shift the transmission into neutral.
2. Pull the hot start lever and kick-start the engine. (Do not open the throttle.)
3. As soon as the engine starts, release the hot start lever.

Starting the engine excessively charged with fuel by throttle blipping or other reasons:

1. Shift the transmission into neutral.
2. With the throttle fully opened, repeat kickstarter operation approximately 10 times very slowly to discharge excessive fuel from the engine.
3. Pull the hot start lever and kick-start the engine (Do not open the throttle.)
4. As soon as the engine starts, release the hot start lever.

Stopping The Engine

1. Shift the transmission into neutral.
2. Turn the fuel valve OFF.
3. Lightly open the throttle 2 – 3 times, and then close it.
4. Depress and hold the engine stop button until the engine stops completely.

NOTE:

- Failure to close the fuel valve may cause the carburetor to overflow.

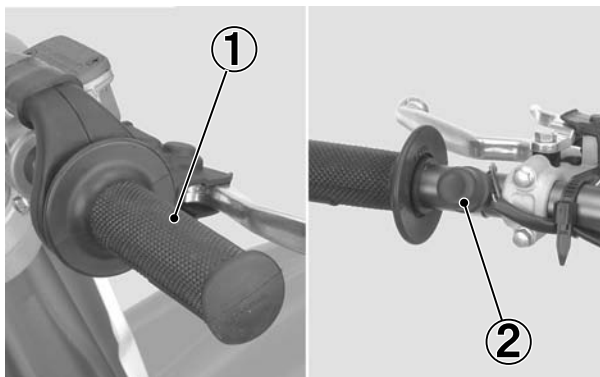

(1) THROTTLE GRIP

(2) ENGINE STOP BUTTON

Break-In Procedure

Help assure your CRF's future reliability and performance by paying extra attention to how you ride during the first operating day or 15 miles (25 km). During this period, avoid full-throttle starts and rapid acceleration.

This same procedure should be followed each time when:

- Piston is replaced
- Rings are replaced
- Cylinder is replaced
- Crankshaft or crank bearing are replaced

1. OPERATING INSTRUCTIONS

CONTROLS

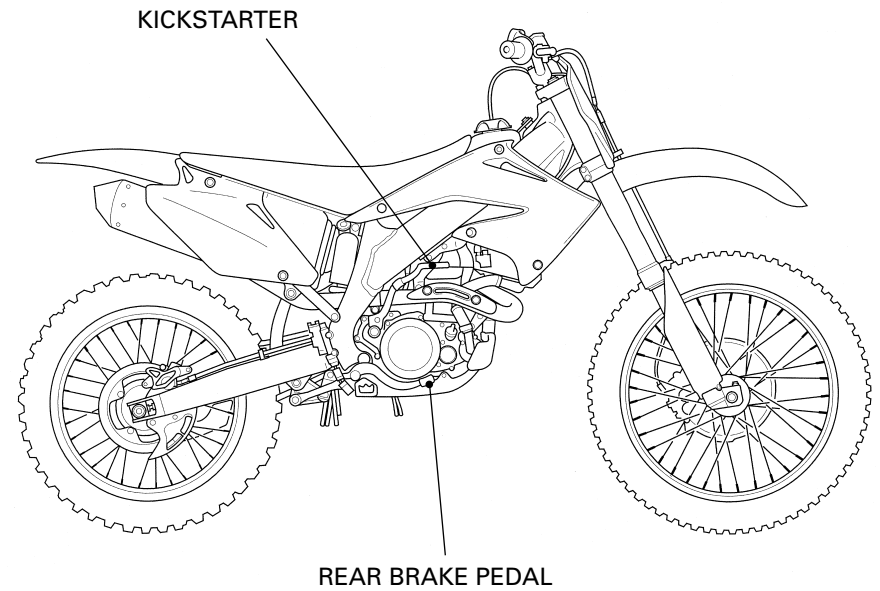
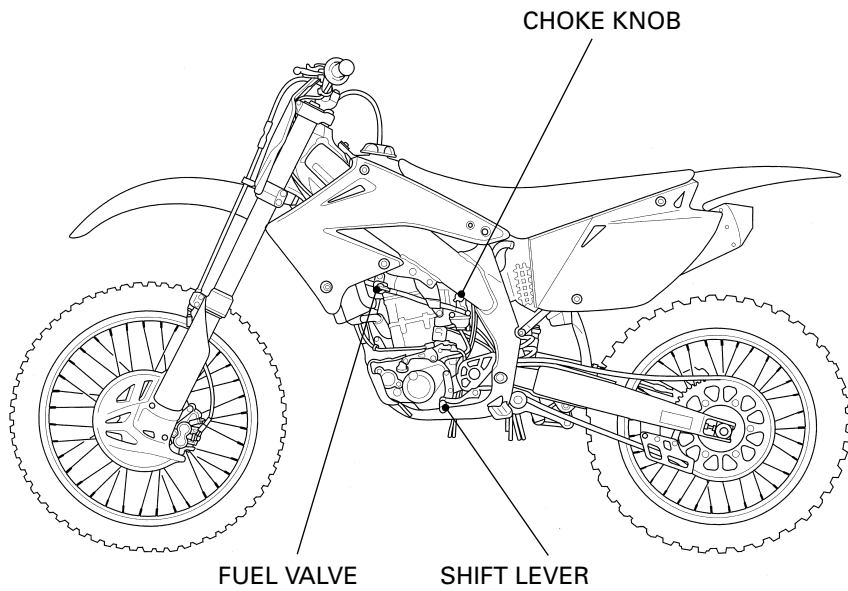
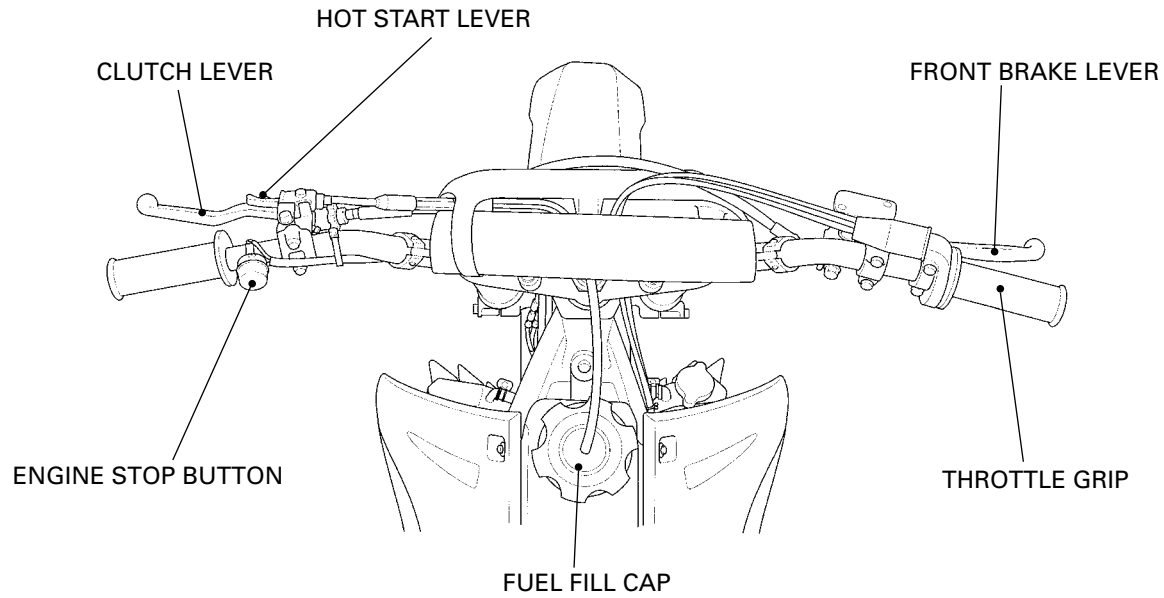

CONTROL ADJUSTMENT

Clutch Lever Position

CAUTION:

- **Make sure to adjust the clutch lever free play after the clutch lever position adjustment or clutch cable disconnected.**

1. The clutch lever position can be adjusted by loosening the lock nut and turning the adjuster. Turning the adjuster counterclockwise moves the clutch lever farther away from the grip; turning the adjuster clockwise moves the clutch lever closer to grip. Tighten the lock nut securely.

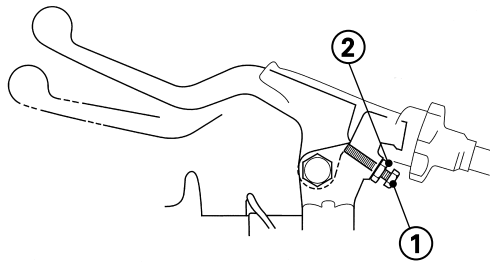

(1) ADJUSTER (2) LOCK NUT

2. Turn the cable end adjuster in direction A until it seats lightly and then turn it out 5 turns.

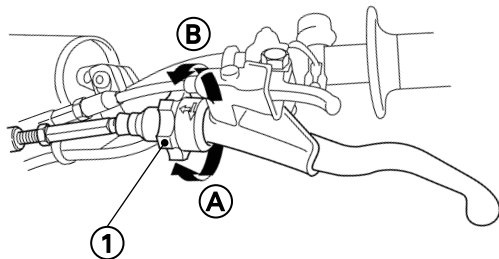

(1) CABLE END ADJUSTER
(A) INCREASE
(B) DECREASE

3. Loosen the lock nut and turn the integral cable adjuster to adjust the clutch lever free play $3/8 - 3/4$ in (10 - 20 mm) at the tip of lever. Tighten the lock nut.

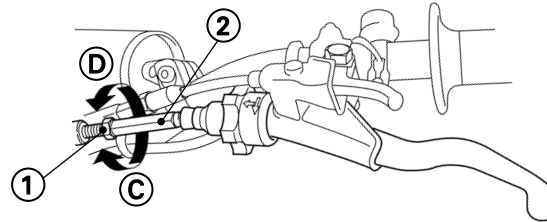

(1) LOCK NUT
(2) INTEGRAL CABLE ADJUSTER
(C) INCREASE
(D) DECREASE

4. Adjust the cable end adjuster for minor adjustment.

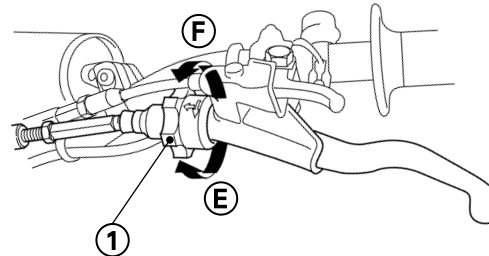

(1) CABLE END ADJUSTER
(E) INCREASE
(F) DECREASE

Clutch Lever Free Play

1. The normal clutch lever free play is $3/8 - 3/4$ in (10 - 20 mm) at the tip of the lever.

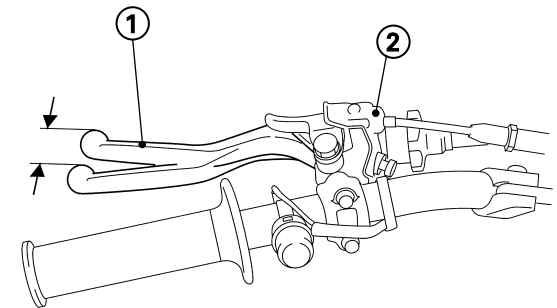

(1) CLUTCH LEVER (2) DUST COVER

2. Minor adjustments can be made with the cable end adjuster.

Turning the adjuster in direction A will increase free play and turning it in direction B will decrease free play.

If the adjuster is threaded out near its limit or the correct free play cannot be reached, turn the adjuster all the way in and back out one turn and make the adjustment with the integral cable adjuster.

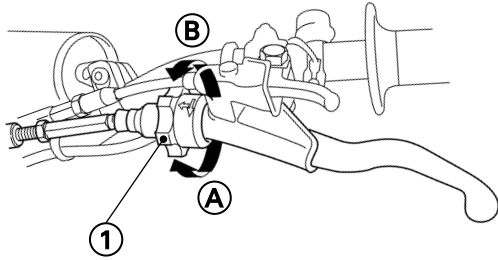

(1) CABLE END ADJUSTER
(A) INCREASE (B) DECREASE

- Major adjustments can be made at the integral cable adjuster. Loosen the lock nut and turn the adjuster. Turning the adjuster in direction C will increase free play and turning it in direction D will decrease free play. Tighten the lock nut after adjusting.
- Test ride to be sure the clutch operates properly without slipping or dragging.

NOTE :

- If proper adjustment still cannot be obtained or the clutch does not operate correctly, see pages 28 – 30, refer to the Honda Service Manual, or see your authorized Honda dealer for clutch disassembly and wear inspection.

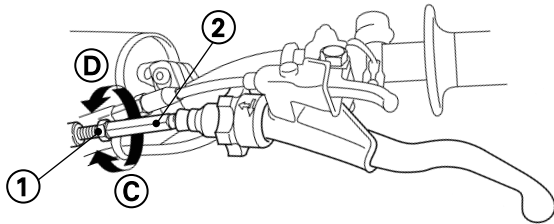

(1) LOCK NUT (2) INTEGRAL CABLE ADJUSTER
(C) INCREASE (D) DECREASE

Hot Start

- The normal hot start lever free play is 1/16 – 1/8 in (2 – 3 mm) at the tip of the lever.

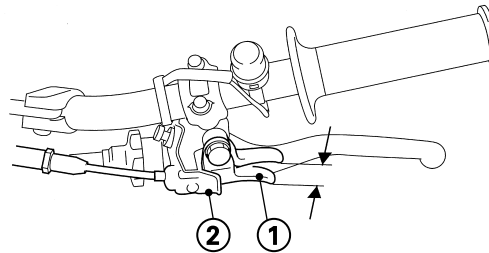

(1) HOT START LEVER
(2) DUST COVER

- Adjustments can be made with the cable end adjuster. Loosen the lock nut and turn the adjuster. Turning the adjuster in direction A will increase free play and turning in direction B will decrease free play. After adjustment, tighten the lock nut.

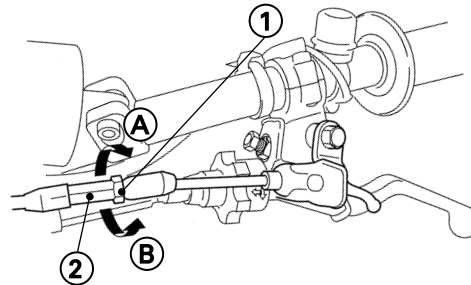

(1) LOCK NUT (2) CABLE ADJUSTER
(A) INCREASE (B) DECREASE

Throttle Grip

Standard throttle grip free play is approximately 1/8 – 3/16 in (3 – 5 mm) of grip rotation.

- Minor adjustment is made with the upper adjuster. Remove the dust cover and loosen the lock nut. Turning the adjuster in direction A will increase free play and turning it in direction B will decrease free play. Tighten the lock nut and reinstall the dust cover after adjustment. If the adjuster is threaded out near its limit or the correct free play cannot be reached, turn the adjuster all the way in and back out one turn. Tighten the lock nut, install the dust cover and make the adjustment with the carburetor top adjuster.

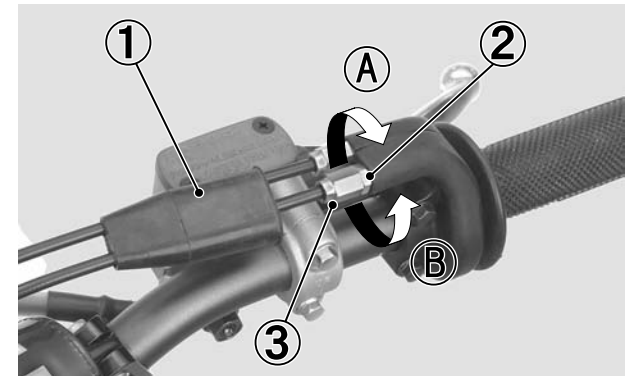

(1) DUST COVER (2) LOCK NUT
(3) UPPER ADJUSTER (A) INCREASE (B) DECREASE

2. Remove the fuel tank (page 17).
3. To make major adjustments, loosen the lock nut. Turn the adjuster in direction C to increase free play, and in direction D to decrease free play. Tighten the lock nut.
4. Install the fuel tank (page 18).
5. Operate the throttle grip to ensure that it functions smoothly and returns completely.

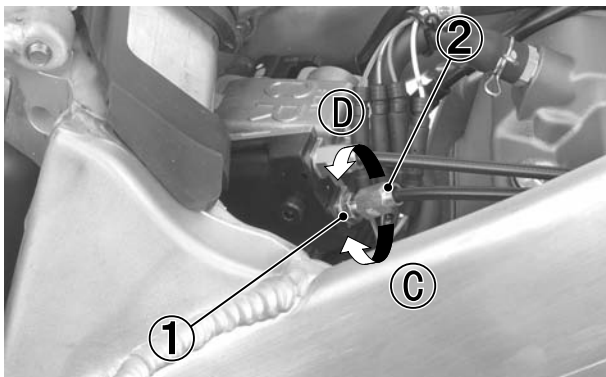

(1) LOCK NUT
(2) ADJUSTER
(C) INCREASE
(D) DECREASE

Front Brake Lever

The front brake lever position can be adjusted by loosening the lock nut and turning the adjuster. Turning the adjuster clockwise moves the brake lever farther away from the grip; turning the adjuster counterclockwise moves the brake lever closer to the grip.

Tighten the lock nut securely.

If the brake lever free play exceeds 0.8 in (20 mm), there is probably air in the brake system and it must be bled. Refer to the Honda Service Manual or see your authorized Honda dealer for brake bleeding.

CAUTION:

- Apply grease to the contacting faces of the adjuster and piston.

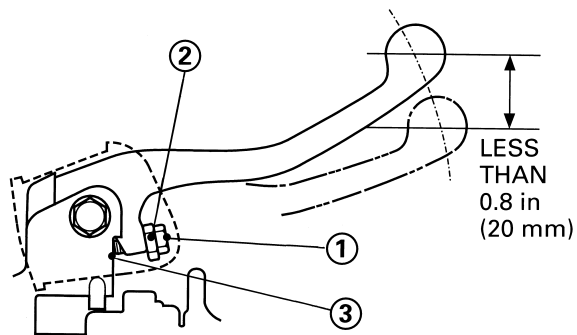

(1) ADJUSTER (2) LOCK NUT (3) PISTON

Brake Pedal Height

The brake pedal height should be approximately level with the right footpeg.

To adjust the rear brake pedal height:

1. Loosen the lock nut and turn the adjusting bolt in direction A to raise the pedal, or in direction B to lower it.
2. Tighten the lock nut at the desired pedal height.

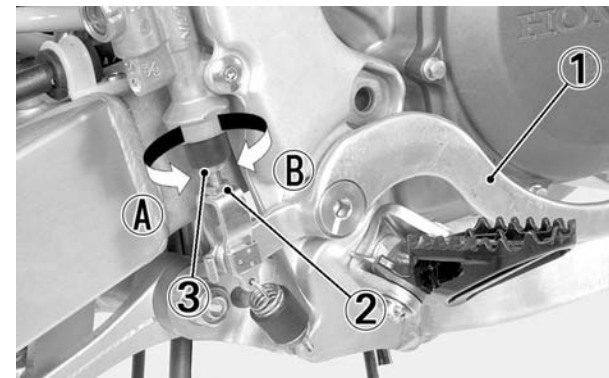

(1) REAR BRAKE PEDAL (2) LOCK NUT
(3) ADJUSTING BOLT
(A) RAISE THE PEDAL HEIGHT
(B) LOWER THE PEDAL HEIGHT

1. OPERATING INSTRUCTIONS

ADJUSTMENT FOR PERSONAL FIT

Control Positioning

- Position the control levers so that control use is comfortable when both seated and standing.
- Adjust control lever mounting bolt torque so that the levers will rotate on the handlebar in a fall, rather than bending or breaking. Apply Honda Thread Lock or an equivalent to the threads of these bolts prior to adjustment to help ensure the correct torque is retained. Tighten the top bolts first.

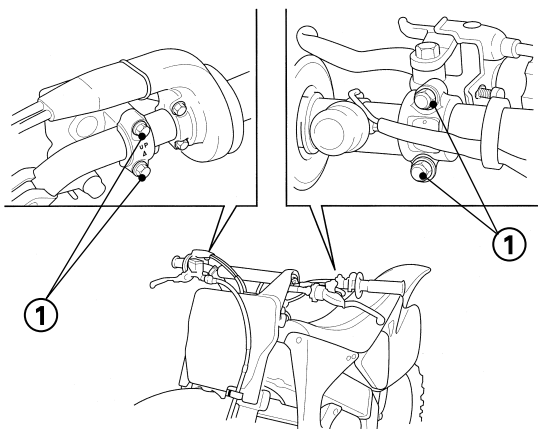

(1) CONTROL LEVER MOUNT BOLTS

- Position the shifter and brake pedal so that they are close to your boot for rapid access, but not so close that either is depressed when sitting or standing comfortably on the bike.

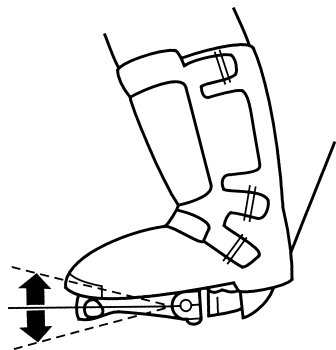

Handlebar Position, Width & Shape

- Position the handlebar so that both gripping the bar and operating the controls are comfortable while both seated and standing, while riding straight ahead and turning. Tighten the forward bolts first.
- The handlebar position may be moved rearward either 3 mm (using optional handlebar lower holders) or 6 mm (by rotating the standard holders 180 degrees). Refer to the Service Manual for installation instructions. Be sure to check the control cable and wiring harness routing after adjustment.
- Handlebar width can be trimmed with a hacksaw to better suit your particular shoulder width and riding preference. Think this through carefully and cut off just a small amount at a time from both sides equally. It is obviously much easier to make the handlebar narrower than it is to add material.

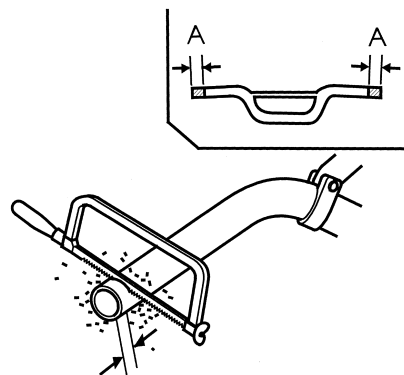

NOTE:

- Chamfer the edges to remove burrs and other irregularities or roughness after sawing the handlebar.
- An alternate handlebar shape, through varying rise or rearward sweep dimensions, will provide further adjustment to riding position and may better suit your particular body size or riding style. Each of the ergonomic dimensions of the machine were determined to suit the greatest possible number of riders based on an average size rider.

Additional Individualized Adjustments

- Initial suspension adjustments should be performed after a minimum of two hours of easy break-in time. Complete information on suspension adjustment is given in the Suspension Adjustment section.
- Optional front and rear suspension springs (front: stiffer and softer, rear: stiffer and softer) are available to tailor your CRF specifically for your weight, riding style and course conditions. Follow the instructions given in the rear suspension sag setting section of Suspension Adjustment to determine if your combined rider and sprung machine weight (rider fully dressed for competition and machine coolant, oil and fuel levels ready for competition) requires an optional stiffer or softer rear spring. The use of the stiffer rear spring may need to be balanced by the use of the stiffer front spring.
- In order to further fine tune your CRF for specific course terrain and conditions, there is a choice of both higher and lower final drive ratios with two optional aluminum driven sprockets. For muddy or sandy courses, there is a more durable steel driven sprocket with the standard number of teeth. Like the optional springs, these sprockets are listed in the optional parts section of this manual.

2. SPECIFICATIONS

| Item | English | Metric |
|---|--|---------------------|
| Dimension | | |
| Overall length | 86.4 in | 2,194 mm |
| Overall width | 32.6 in | 827 mm |
| Overall height | 49.7 in | 1,262 mm |
| Wheelbase | 58.9 in | 1,495 mm |
| Seat height | 37.6 in | 954 mm |
| Footpeg height | 16.9 in | 430 mm |
| Ground clearance | 13.3 in | 338 mm |
| Dry weight | 224.9 lbs | 102 kg |
| Frame | | |
| Type | Twin tube | |
| F. suspension | Telescopic fork, travel 11.1 in (281 mm) stroke 12.4 in (315 mm) | |
| R. suspension | Pro-link, travel 12.6 in (319 mm) | |
| F. tire size, pressure psi (kPa, kgf/cm ²) | 80/100 – 21 M/C 51M 15 (100, 1.0) | |
| R. tire size, pressure psi (kPa, kgf/cm ²) | 110/90 – 19 M/C 62M 15 (100, 1.0) | |
| F. brake, swept area | Single disc brake 51.8 in ² (334.5 cm ²) | |
| R. brake, swept area | Single disc brake 60.6 in ² (391.1 cm ²) | |
| Fuel capacity | 2.0 US gal 1.6 Imp gal | 7.4 liter |
| Caster angle | 26.91° | |
| Trail length | 4.3 in | 108 mm |
| Fork oil capacity (except fork damper per leg) | 14.1 US oz | 416 cm ³ |

| Item | English | Metric |
|--|-------------------------------------|-----------------------|
| Engine | | |
| Type | Liquid cooled, 4-stroke | |
| Cylinder arrangement | Single 6° inclined from vertical | |
| Bore and stroke | 3.78 x 2.44 in | 96.0 x 62.1 mm |
| Displacement | 27.41 cu-in | 449.4 cm ³ |
| Compression ratio | 12.0 : 1 | |
| Engine oil capacity After draining | 0.70 US qt 0.58 Imp qt | 660 cm ³ |
| After draining and oil filter change | 0.73 US qt 0.61 Imp qt | 690 cm ³ |
| After disassembly | 0.90 US qt 0.75 Imp qt | 850 cm ³ |
| Transmission oil capacity After draining | 0.62 US qt 0.52 Imp qt | 590 cm ³ |
| After disassembly | 0.71 US qt 0.59 Imp qt | 670 cm ³ |
| Carburetor | | |
| Type | Piston valve | |
| Identification number | FCR00C | |
| Main jet (standard) | # 165 | |
| Jet needle (standard) | NCYR | |
| Needle clip position (standard) | 4th groove | |
| Slow jet (standard) | # 42 | |
| Pilot screw opening | 1–1/2 turns out | |
| Float level | 0.31 in | 8.0mm |

| Item | English | Metric |
|-----------------------------------|---|--------|
| Drive train | | |
| Clutch type | Wet, multi-plate type | |
| Transmission | 5-speed, constant mesh | |
| Primary reduction | 2.739 | |
| Gear ratio I | 1.800 | |
| Gear ratio II | 1.470 | |
| Gear ratio III | 1.235 | |
| Gear ratio IV | 1.050 | |
| Gear ratio V | 0.909 | |
| Final reduction | 3.692 | |
| Gear shift pattern | Left foot-operated return system 1-N-2-3-4-5 | |
| Electrical | | |
| Ignition | CDI | |
| Starting system | Kickstarter | |
| Spark plug : Standard | NGK IFR8H11 | |
| | DENSO VK24PRZ11 | |
| For extended high speed riding | NGK IFR9H11 | |
| | DENSO VK27PRZ11 | |



3. OPTIONAL PARTS



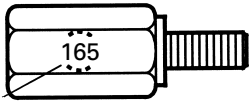
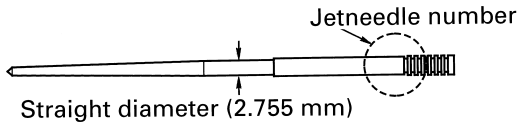
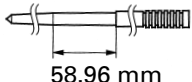
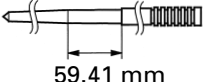

OPTIONAL PARTS LIST

These parts and tools may be ordered from your authorized Honda dealer.

| CARBURETOR | | Remarks |
|--|--|--|
| Main jet (Standard: #165) | #155 – #175 (in increments of 2 or 3) |  Size |
| Slow jet (Standard: #42) | #38 – #48 (in increments of 2 or 3) | |
| Jet Needles Standard needle: NCYR Straight diameter: $\varnothing 2.755$ mm  | | |
| | Jet needle number (standard series) | Jet needle number (1/2 clip position richer than standard series. richer only at 1/8 to 3/4 throttle) |
| |  58.96 mm |  59.41 mm |
| General flow characteristics Richer ↑ Leaner ↓ (at 1/16 to 1/4 throttle) | NCYP $\varnothing 2.735$ mm | NCVP $\varnothing 2.735$ mm |
| | NCYQ $\varnothing 2.745$ mm | NCVQ $\varnothing 2.745$ mm |
| | (standard needle) NCYR $\varnothing 2.755$ mm | NCVR $\varnothing 2.755$ mm |
| | NCYS $\varnothing 2.765$ mm | NCVS $\varnothing 2.765$ mm |
| | NCYT $\varnothing 2.775$ mm | NCVT $\varnothing 2.775$ mm |

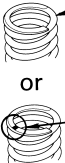
| FRAME | Remarks |
|---------------------------------------|---|
| Driven sprocket Standard | < >: Drive chain links 48 Teeth, Aluminum. <114> |
| Optional | 47 Teeth, Aluminum <112> 49 Teeth, Aluminum <114> |
| Handlebar lower holder Standard | 3 mm offset |
| Optional | no offset |
| Front wheel Standard | 21 inch Fork height: 0.3 in (7.0 mm) (align the index groove with the top of the upper clamp) |
| Optional | 20 inch <ul style="list-style-type: none"> wheel assembly (except brake disk) tire tube tire flap rim lock (bead stopper) front tire (90/100-20, 90/100-20 M/C) Fork height: 0 in (0 mm) (align the top of the fork tube with the top of the upper clamp) |

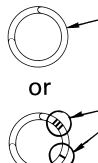
| TOOLS | Remarks |
|--|--|
| Pin spanner A  | To adjust spring preload. (two spanners required) |
| Workstand  | For maintenance |
| Air gauge | For checking tire air pressure. |

| FRAME | Remarks |
|--------------------------|---|
| Shock spring Standard | 308.0 lbf/in (5.50kgf/mm) No mark (factory products) or Red paint (aftermarket parts)  |
| Optional Softer | 296.8 lbf/in (5.30kgf/mm)  Blue paint |
| Stiffer | 319.2 lbf/in (5.70kgf/mm) Pink paint 330.4 lbf/in (5.90kgf/mm) Silver paint  |
| Fork spring Standard | 26.32 lbf/in (0.47kgf/mm) No mark (factory products) or 1 scribe mark and 3 scribe mark 75 degrees apart (aftermarket parts)  |
| Optional Softer | 25.20 lbf/in (0.45kgf/mm)  1 scribe mark and 2 scribe mark 75 degrees apart |
| Stiffer | 27.44 lbf/in (0.49kgf/mm)  1 scribe mark and 2 scribe mark 75 degrees apart |

The standard fork spring and shock spring mounted on the motorcycle when it leaves the factory are not marked. Before replacing the springs, be sure to mark them so they can be distinguished from other optional springs.

4. SERVICE AND MAINTENANCE

PRE-RIDE INSPECTION CHECK LIST

Pre-ride Inspection

▲WARNING

- ***If the Pre-ride and Pre-race inspection are not performed, severe personal injury or vehicle damage may result.***
- Engine oil level 21
- Transmission oil level 23
- Coolant level 24
- Cooling system and hoses for condition 24
- Spark plug for proper heat range, carbon fouling and high tension cord terminal for looseness 25
- Air cleaner for condition and contamination ... 27
- Clutch operation and free play 5
- Hot starter operation and free play 6
- Breather drain for cleaning 27
- Steering head bearings and related parts for condition 47
- Carburetor throttle operation..... 6, 47
- Engine idle speed for stable and proper RPM 26
- Tires for damage or improper inflation pressure 49
- Spokes for looseness 49
- Rim locks for looseness 49
- Front and rear suspension for proper operation 49, 50
- Front and rear brakes, check operation 7, 51
- Drive chain for correct slack and adequate lubrication 52
- Drive chain guide, sliders and guide rollers for damage or wear 54
- Every possible part for looseness (such as cylinder head nuts, engine mounting bolts, axle nuts, handlebar holder bolts, fork triple clamp bolts, drive chain adjuster, drive chain guide, wire harness connectors, kickstarter mounting bolt, etc.) 58

MAINTENANCE SCHEDULE

Perform the Pre-ride Inspection at each scheduled maintenance period.

I: Inspect and Clean, Adjust, Lubricate or Replace if necessary. C: Clean. R: Replace. L: Lubricate.

| ITEMS | FREQUENCY | NOTE | Each race or about 2.5 hours | Every 3 races or about 7.5 hours | Every 6 races or about 15.0 hours | Every 9 races or about 22.5 hours | Every 12 races or about 30.0 hours | Ref. Page |
|---------------------------------------|------------------|----------|------------------------------|----------------------------------|-----------------------------------|-----------------------------------|------------------------------------|-----------|
| | | | | | | | | |
| THROTTLE OPERATION | | | I | | | | | 6 |
| HOT START SYSTEM | | | I | | | | | 6 |
| AIR FILTER | | (NOTE 1) | C | | | | | 27 |
| CRANKCASE BREATHER | | | I | | | | | 27 |
| SPARK PLUG | | | I | | | | | 25 |
| RADIATOR COOLANT | | (NOTE 2) | I | | | | | 24 |
| VALVE CLEARANCE / DECOMPRESSOR SYSTEM | | (NOTE 4) | | | I | | | 30 |
| ENGINE OIL | | (NOTE 3) | | | R | | | 21 |
| ENGINE OIL FILTER | | (NOTE 3) | | | R | | | 21 |
| ENGINE IDLE SPEED | | | I | | | | | 26 |
| PISTON AND PISTON RINGS | | | | | R | | | 39 |
| PISTON PIN | | | | | | | R | 39 |
| TRANSMISSION OIL | | | | | R | | | 23 |
| COOLING SYSTEM | | | I | | | | | 24 |
| DRIVE CHAIN | | | I,L | R | | | | 52 |
| DRIVE CHAIN SLIDER | | | I | | | | | 54 |
| DRIVE CHAIN ROLLER | | | I | | | | | 54 |
| DRIVE SPROCKET | | | I | | | | | 53 |
| DRIVEN SPROCKET | | | I | | | | | 53, 55 |
| BRAKE FLUID | | (NOTE 2) | I | | | | | 51 |
| BRAKE PADS WEAR | | | I | | | | | 52 |
| BRAKE SYSTEM | | | I | | | | | 7 |
| CLUTCH SYSTEM | | | I | | | | | 5, 28 |
| CONTROL CABLES | | | I,L | | | | | 57 |
| EXHAUST PIPE/MUFFLER | | | I | | | | | 55 |
| SUSPENSION | | | I | | | | | 49, 50 |
| SWINGARM/SHOCK LINKAGE | | | | L | | | | 16, 50 |
| FORK OIL | FORK TUBE/SLIDER | (NOTE 3) | | R | | | | 75 |
| | DAMPER | | | | | R | | 83 |
| NUTS, BOLTS, FASTENERS | | | I | | | | | 58 |
| WHEELS/TIRES | | | I | | | | | 49 |
| STEERING HEAD BEARINGS | | | | | | I | | 47 |

This maintenance schedule is based upon average riding condition. Machine subjected to severe use require more frequent servicing.

- NOTE: 1.Clean after every moto for dusty riding condition.
 2.Replace every 2 years. Replacement requires mechanical skill.
 3.Replace after the first break-in ride.
 4.Inspect after the first break-in ride.

4. SERVICE AND MAINTENANCE

GENERAL SERVICE INFORMATION

- Perform maintenance on firm, level ground using the optional workstand or equivalent support.
- Always install new gaskets, O-rings, cotter pins, piston pin clips, snap rings, etc. when reassembling.
- When tightening bolts, nuts or screws, start with the larger diameter or inner fasteners, and tighten them to the specified torque using a crisscross pattern.
- Use genuine Honda parts or their equivalent when servicing your CRF.
- Clean parts in non-flammable cleaning solvent when disassembling. Lubricate any sliding surface, O-rings, and seals before reassembling.

▲ WARNING

- **Gasoline or low flash point solvents are highly flammable or explosive and must never be used for cleaning parts or the air filter element. Fire or explosion could result.**
- After reassembling, check all parts for proper installation and operation.
- Grease parts by coating or filling where specified.

NOTE :

- Specifications are listed on page 9.

BETWEEN MOTO/BETWEEN PRACTICE AND MOTO MAINTENANCE

- Dirt = wear and weight. Clean accumulated dirt from under fenders and off of wheels, suspension, grips, controls and footpegs. A stiff, nylon parts cleaning brush works well.
- Check tire air pressure.
- Check spoke tension and rim lock nut security.

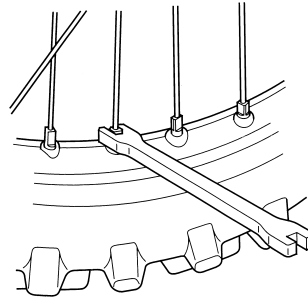

- Check sprocket bolt and nut security.
- Clean chain with a stiff, nylon parts cleaning brush; lubricate and adjust as necessary.

▲ WARNING

- **Do not perform maintenance while engine is running. Injury to your fingers or hands may result.**
- After adjustment, check that the chain adjuster index marks are in the same position on each side to be sure the rear wheel is in proper alignment. This is especially important for best performance from the rear disc brake and to extend pad wear.

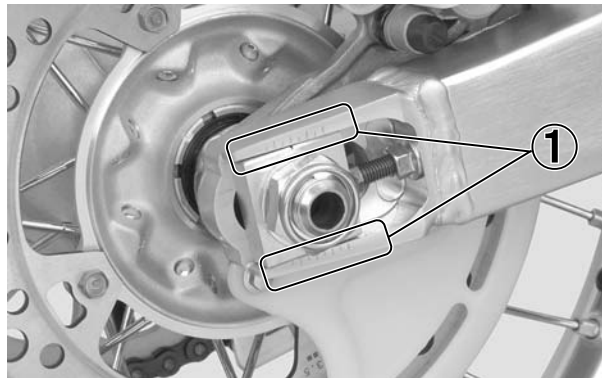

(1) CHAIN ADJUSTER INDEX MARKS

- Release the built-up pressure in the fork tubes (in excess of normal atmospheric pressure: 0 psi) caused by normal fork action while riding. The front wheel should be suspended above ground for this operation.

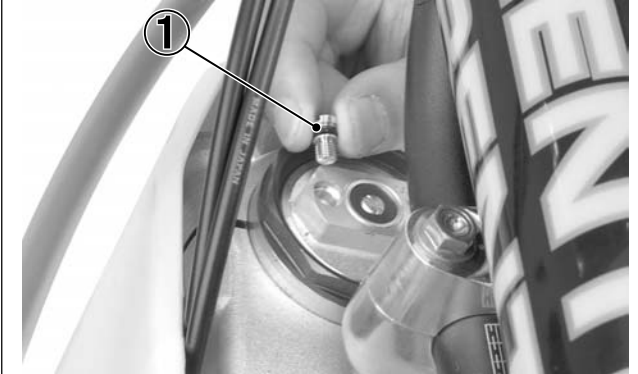

(1) PRESSURE RELEASE SCREWS

AFTER RACE MAINTENANCE

It is important to the long term performance of your CRF to properly maintain your racebike at all times. If you envision the maintenance cycle ending as the machine is fully prepared for practice at the next event and beginning again after that practice, there is clearly work to do in between. After the race is a good place to begin your routine maintenance.

After Race Lubrication

Apply a light coating of rust-inhibiting oil to the drive chain, drive sprocket and any steel portions of the chassis or engine where the paint has worn away and the exposed metal can begin to rust. Apply this rustinhibiting oil more heavily if the event was particularly wet or muddy.

▲ WARNING

- **Take care to prevent catching your fingers between the chain and sprocket.**

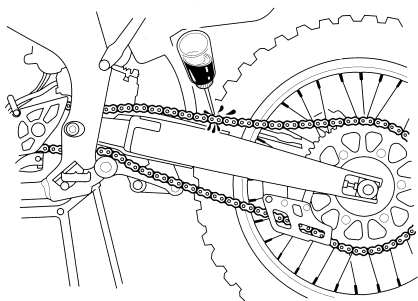

Routine Cleaning

If the machine is only slightly dirty, it is best to clean it by hand with the aid of a stiff bristled nylon brush and some clean rags. There is no reason to introduce unnecessary moisture.

▲ WARNING

- **Take care to prevent catching your fingers between the chain and sprocket.**

Allow enough time to completely clean and dry your CRF to reduce the possibility of corrosion or rust.

Accumulated dirt should be loosened with a shower of water; then brushed away with suitable brushes, soap and water; then the machine rinsed with clean water and wiped completely dry.

A variety of reasonably priced cleaning brushes are available from variety, drug, food and hardware stores that are extremely useful in removing dirt from the many tight contours of your machine.

Pressurized Spray Washers

CAUTION:

- **There are some areas on your CRF that you should never directly aim the nozzle of a high pressure spray washer. It is tempting to let the pressure of the water remove all the dirt that has accumulated, but control yourself. The force of the water under this extreme pressure can penetrate the dust seals of the suspension pivot points and steering head bearings—driving dirt inside and needed lubrication out. Avoid spraying water under the seat and fuel tank and into the airbox as well.**

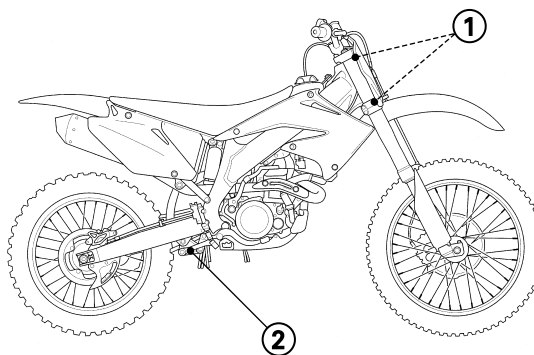

- (1) STEERING HEAD BEARINGS
(2) SUSPENSION PIVOT POINTS

Condensation Control

Some condensation can form within the transmission cavity as well. This is natural and just one more reason you should change the transmission oil often.

After Cleaning Lubrication

Although you can basically follow the suggestions given in the Maintenance section under General Maintenance (pages 14 –16), there are some things you should do just after washing your CRF to help prevent rust and corrosion.

Once your CRF is clean and dry, you should protect any bare steel from rusting by applying a light coating of a rust-inhibitor. Lubricate the drive chain and drive sprocket after removing and thoroughly cleaning in solvent. Be sure the chain is wiped clean and is dry before applying the chain lube.

Follow the suggestions given in the pages of this manual for lubricating items such as the brake and clutch lever pivot points and footpeg pivot pins.

4. SERVICE AND MAINTENANCE

GENERAL MAINTENANCE

- **Spark Plugs:** Some non-resistor plugs may cause ignition problems. Refer to the recommendations elsewhere in this manual for specific types so you will be sure to use the proper reach and heat range. Replace periodically as specified in the Maintenance Schedule. (pages 11, 25)

- **Spark Plug Cap:** Install a small plastic tie-wrap around the spark plug cap to reduce any possibility of it loosening or of water penetration.

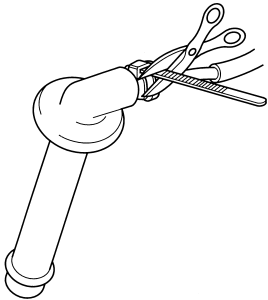

- **Engine Oil and Filter:** Drain and replace engine oil often to ensure the greatest service life of the piston, cylinder and crankshaft. Also replace engine oil filter often to ensure the greatest service life. Frequent changes will also assure consistent performance of power and response. (page 21).

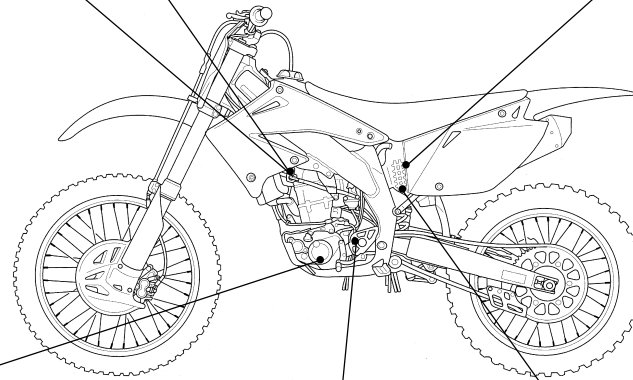

- **Transmission Oil:** Drain and replace transmission oil often to ensure the greatest service life of the transmission and clutch. Frequent changes will also assure consistent performance of both shifting and clutch action. (page 23)

- **Air Cleaner:** Clean and oil your air cleaner regularly because the volume of air able to pass through it has a great effect on performance. Both engine performance and long term durability may be affected by an air cleaner that has deteriorated and allows dirt to pass. Inspect the air cleaner closely each time it's serviced for evidence of small tears or seam separation. Keep a spare air cleaner oiled and ready to install, sealed in a plastic bag. Riding in dusty conditions may require servicing the air cleaner or replacing it with a pre-serviced air cleaner between motos. Be careful not to over oil the air cleaner. While it is important to oil the air cleaner thoroughly, over oiling will cause an overall rich running condition, probably more noticeable off idle and in low rpm performance. Follow the servicing instructions in the Maintenance section. Use Pro Honda Foam Filter Oil or an equivalent. Be sure to grease the air cleaner flange where it contacts the air cleaner housing. Honda White Lithium Grease, or an equivalent, is handy for this because any dirt that penetrates this sealing area will show up clearly. (page 27) Use the Honda genuine air cleaner or an equivalent air cleaner specified for your model. Using the wrong Honda air cleaner or a non-Honda air cleaner which is not of equivalent quality may cause premature engine wear or performance problems.

- **Air Box Sealing:** Remove and reseal the air cleaner housing boot where it connects to the air cleaner housing with silicone sealer if there is any doubt to its sealing integrity. Use Hondalock or an equivalent on the attaching studs. Inspect the air cleaner and air intake tract regularly for signs of deterioration or dirt penetration.

- **Handgrips:** Always use Honda Hand Grip Cement (U.S.A. only) or Honda Bond A when replacing handgrips.

Throttle grip: Align the index mark on the throttle grip with the index mark of the throttle cable guide.
 Left handlebar grip: Align the " " mark on the left handlebar grip with the paint mark on the handlebar. Refer to the Service Manual for installation instructions.

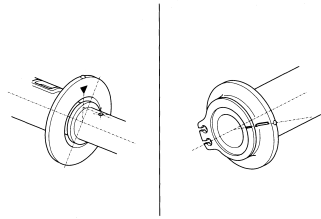

For added security, you may choose to safety wire the hand grips to the handlebar and throttle to prevent the possibility of them loosening. Position the twisted wire ends away from your palms and be sure to bend the wire ends well into the grip rubber so they will not snag your glove.

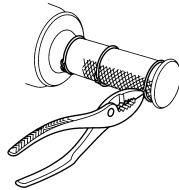

- **Throttle Control:** Remove the throttle control every few rides, clean the inside of the drum and the handlebar thoroughly, and apply a light coating of silicone lubricant. Inspect the cable carefully for kinks or other damage that may restrict throttle control in anyway. Move the handlebar from lock to lock to be sure there is no cable interference. Check to be sure the top of the carburetor is screwed on tight. Make certain the throttle operation is perfect after servicing and inspecting.

- **Fuel Filter:** Periodically drain the fuel from the tank, remove and clean the fuel filter. Replace the fuel filter O-ring if there are any signs of damage or deterioration. (page 48)
- **Fuel Contamination:** Periodically drain the float bowl and inspect the carburetor for contamination from dirt. (page 62)

- **Gaskets:** Always use new gaskets when reassembling components.
- **Cylinder Removal:** Put a little grease on the cylinder mounting dowels to prevent corrosion from dissimilar metals. The tolerances are quite tight, so it's important to keep these dowels absolutely clean.

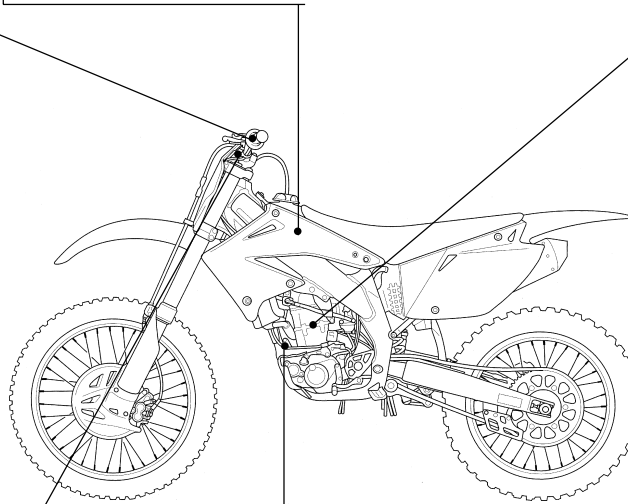

- **Engine Mounting Bolts:** Make sure the engine mounting bolts are tightened to the proper torque specification. For added peace of mind, remove the nuts, clean the threads, and apply Honda Thread Lock or an equivalent prior to torquing the nuts.

- **Electrical Connectors:** Clean electrical connectors and wrap them with electrical tape to reduce the possibility of unwanted disconnections, water shorts or corrosion. Additional corrosion protection is offered by using Honda Dielectric Grease on all electrical connections.

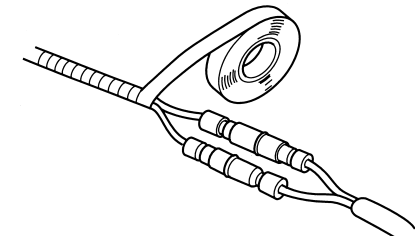

4. SERVICE AND MAINTENANCE

- **Suspension Linkage Lubrication:** Disassemble, clean, inspect and lubricate all pivot bearings after each 7.5 hours of running time in order to maintain proper suspension performance and minimize component wear. Use Honda Moly 60 Paste (U.S.A. only) or molybdenum disulfide paste (containing more than 40% molybdenum disulfide additive).

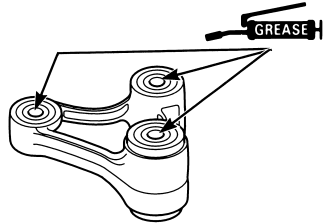

- **Swingarm Pivot Lubrication:** Clean, inspect and lubricate when servicing suspension linkage pivots. Be sure all of the suspension pivot seals are in good condition. Use Honda Moly 60 Paste (U.S.A. only) or molybdenum disulfide paste (containing more than 40% molybdenum disulfide additive).

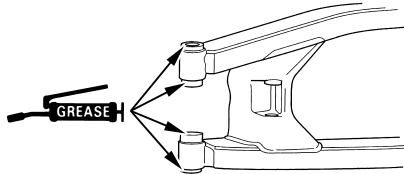

- **Swingarm:** Do not attempt to weld or otherwise repair a damaged swingarm. Welding will weaken the swingarm.
- **Footpegs:** Worn footpeg teeth can be repaired by filing the grooves between the teeth with a triangular-shaped file. Be aware that filing them too sharp will reduce boot sole lifespan. Sharpen only the points of the teeth. Filing the grooves deeper will weaken the footpegs. Be sure the pegs are free to pivot freely and that the pivot pin retaining cotter pins are in good condition.

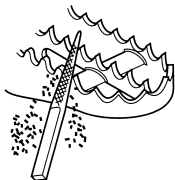

- **Brake Fluid Replacement:** Replace the hydraulic fluid in the brake system every two years.

- **Steering Head Bearings:** Periodically clean, inspect and regrease the steering head bearings especially if wet, muddy or extremely dusty courses are encountered often.

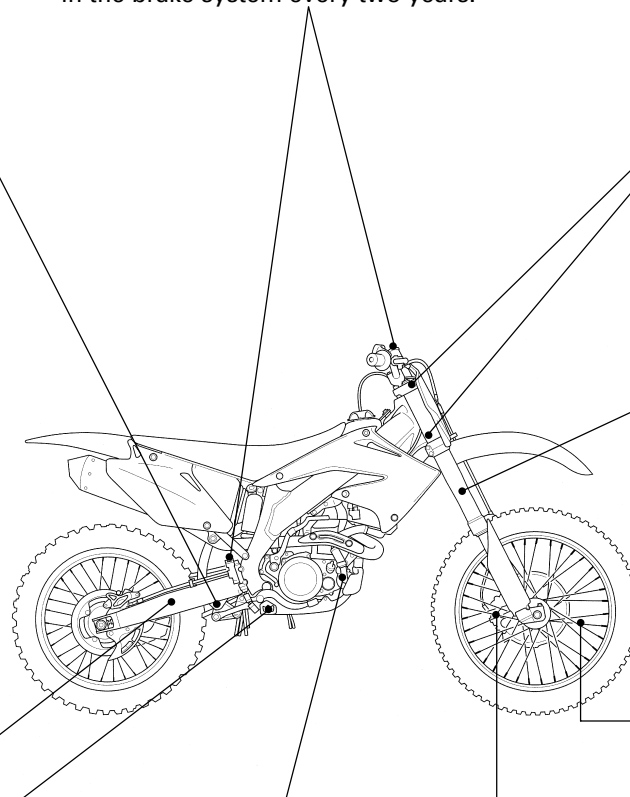
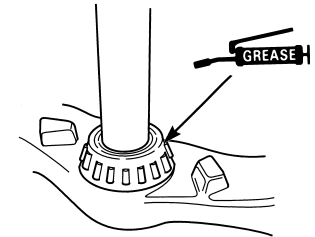

- **Fork Oil/Performance:** Disassemble, clean and inspect the fork and replace the oil regularly. Contamination due to the tiny metal particles produced from the normal action of the fork, as well as normal oil breakdown, will deteriorate the performance of the suspension. Refer to the Honda Service Manual. Use only Pro Honda HP Fork Oil 5W or equivalent which contains special additives to assure maximum performance of your CRF's front suspension.

Frame: Because your CRF is a high-performance machine, the frame should not be overlooked as part of your overall competition maintenance program. Periodically inspect the frame closely for possible cracking or other damage. It makes good racing sense.

- **Water Pump Inspection Hole:** After every race, check the inspection hole, located just below the water pump cover on the right crankcase cover. Clean away any clogged dirt or sand, if necessary. Look for coolant or oil leakage. Leaking coolant indicates a worn or damaged water seal. Leaking oil indicates a bad transmission oil seal. If replacement is necessary, both seals should be replaced.

Spokes: Check spoke tension frequently between the first few rides. As the spokes, nipples and rim contact points seat-in, the spokes may need to be re-tightened. Once past this initial seating-in period, the spokes should hold their tension. Still, be sure your race maintenance program includes checking spoke tension and overall wheel condition on a regular basis. (page 49)

- **Brake Caliper Inspection:** Be sure both front and rear calipers are able to move freely on the caliper bracket pins. Check pad thickness periodically and replace when minimum thickness is reached.

- **Nuts, Bolts, Etc.:** Application of a thread locking agent to essential fasteners offers added assurance and security. Remove the nuts, clean the threads of both the nuts and bolts, apply Honda Thread Lock or an equivalent and tighten to the specified torque.

MAINTENANCE PREPARATIONS

SEAT

Seat Removal

1. Remove the seat bolts and collars.
2. Slide the seat back.

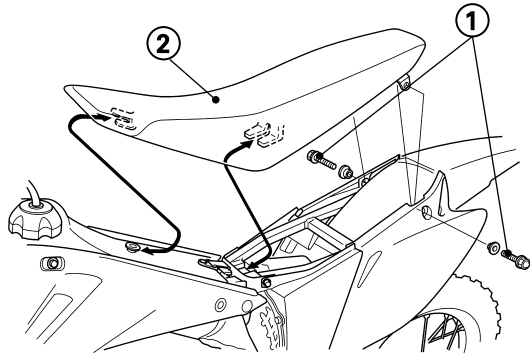

(1) SEAT BOLTS

(2) SEAT

Seat Installation

1. Slide the seat front prong onto the seat bracket and the seat rear prongs onto the tabs by pushing down and forward on the seat in each of these areas.
2. Install the collars and tighten the seat bolts.

TORQUE: 20 lbf·ft (26 N·m, 2.7 kgf·m)

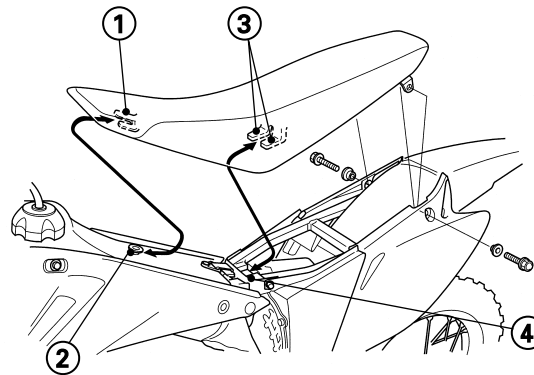

(1) SEAT FRONT PRONG
(3) SEAT REAR PRONGS

(2) SEAT BRACKET
(4) TABS

FUEL TANK

Fuel Tank Removal

1. Turn the fuel valve OFF.
2. Remove the seat (this page).
3. Remove the shroud A bolts and collars.
4. Remove the shroud B bolts, collars and shrouds.

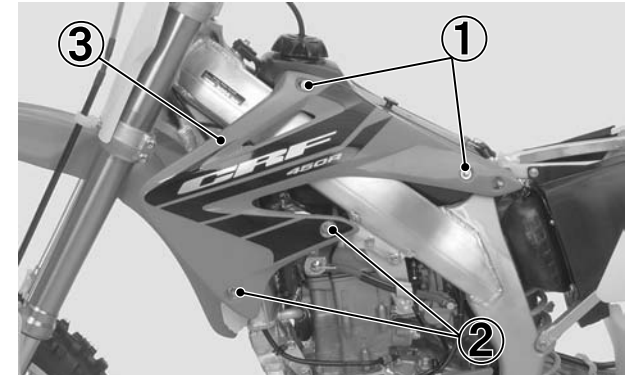

(1) SHROUD A BOLTS/COLLARS
(2) SHROUD B BOLTS/COLLARS
(3) SHROUD

5. Pull the breather tube out of the steering stem nut.
6. Unhook and remove the fuel tank band.
7. Remove the fuel tank bolt.

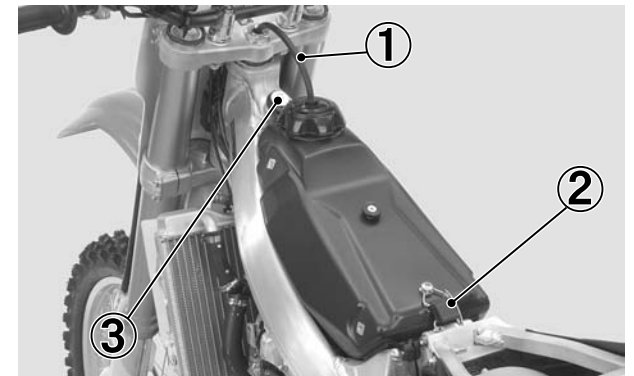

(1) BREATHER TUBE
(2) FUEL TANK BAND
(3) FUEL TANK BOLT

4. SERVICE AND MAINTENANCE

- Disconnect the fuel line from the fuel valve.
The fuel line leading to the carburetor must be disconnected, not the fuel line leading to the fuel tank.
- Remove the fuel valve bolt and fuel valve.
- Remove the fuel tank.

▲WARNING

- Gasoline is extremely flammable and is explosive under certain conditions. Perform this operation in a well-ventilated area with the engine stopped. Do not smoke or allow flames or sparks in the area where gasoline is drained or stored and where the fuel tank is refueled.**

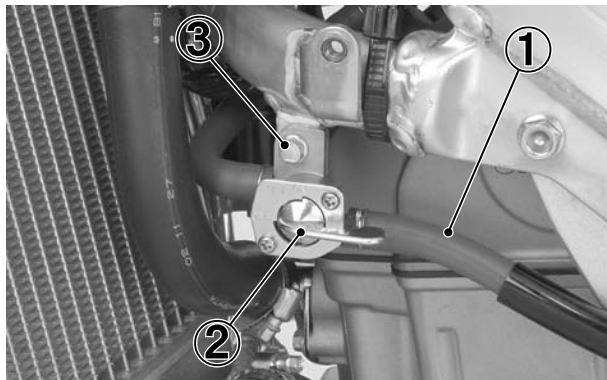

(1) FUEL VALVE
(2) FUEL VALVE BOLT
(3) FUEL LINE

Fuel Tank Installation

- Install the fuel tank on the frame.
- Install the fuel valve and fuel valve bolt.
- Connect the fuel line.

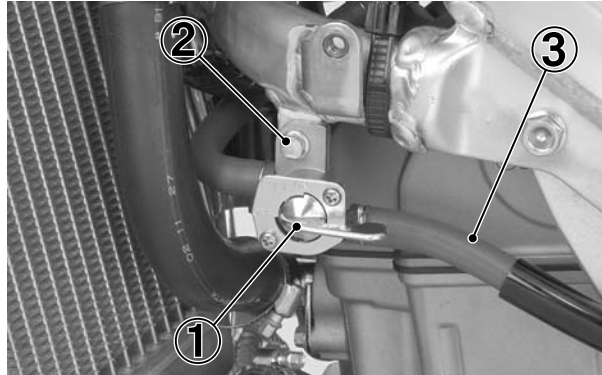

(1) FUEL VALVE
(2) FUEL VALVE BOLT
(3) FUEL LINE

- Install the fuel tank bolt.
- Hook the fuel tank band.

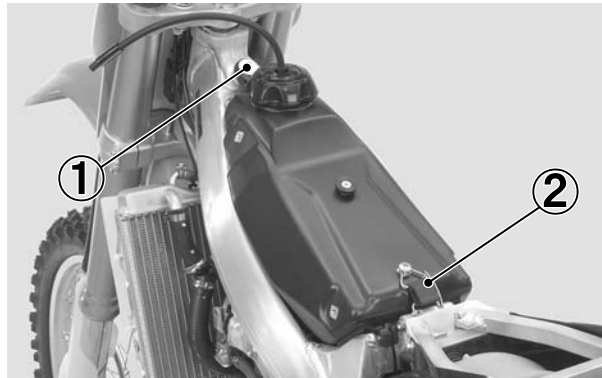

(1) FUEL TANK BOLT
(2) FUEL TANK BAND

- Put the breather tube in the steering stem nut.



(1) BREATHER TUBE

- Install the shrouds, collars and shroud B bolts.
- Install the collars and shroud A bolts.

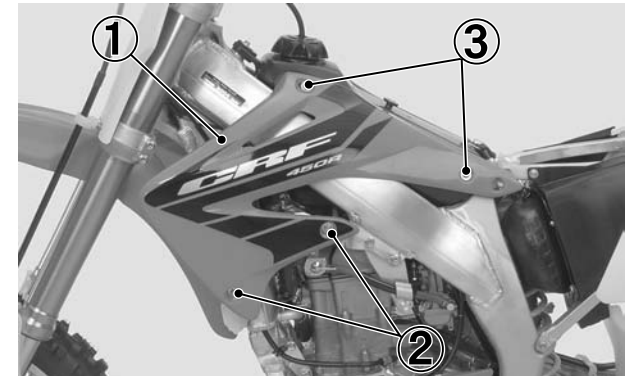

(1) SHROUD
(2) SHROUD B BOLTS/COLLARS
(3) SHROUD A BOLTS/COLLARS

- Install the seat (page 17)

SUBFRAME

Subframe Removal

1. Remove the seat (page 17).
2. Remove the side cover bolts, collars and side covers.



- (1) SEAT
- (2) SIDE COVER BOLTS/COLLARS
- (3) SIDE COVER

3. Loosen the muffler clamp bolt.
4. Remove the muffler A bolt, muffler B bolt/washer and muffler.

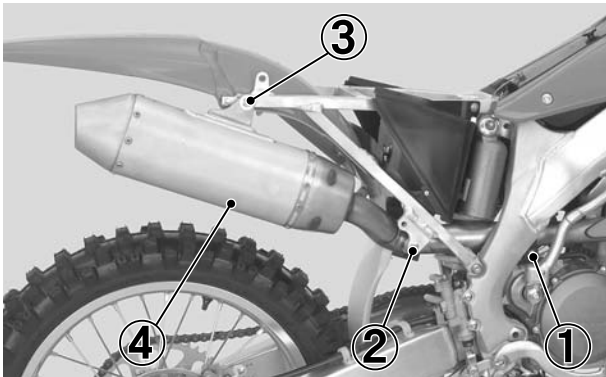

- (1) MUFFLER CLAMP BOLT
- (2) MUFFLER A BOLT
- (3) MUFFLER B BOLT/WASHER
- (4) MUFFLER

5. Disconnect the crankcase breather tube.
6. Loosen the screw on the air cleaner connecting tube clamp.

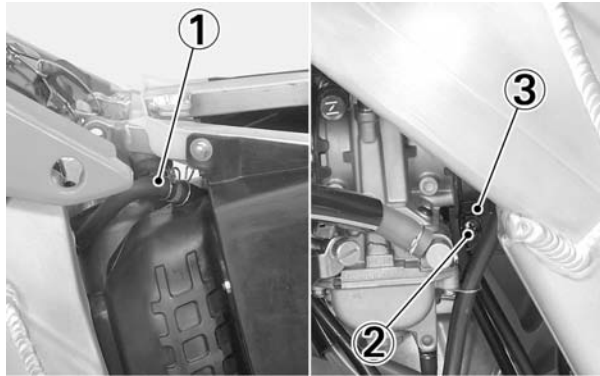

- (1) CRANKCASE BREATHER TUBE
- (2) SCREW
- (3) AIR CLEANER CONNECTING TUBE CLAMP

7. Remove the subframe mounting A bolts and subframe mounting B bolt. Then remove the subframe by pulling it straight backward.

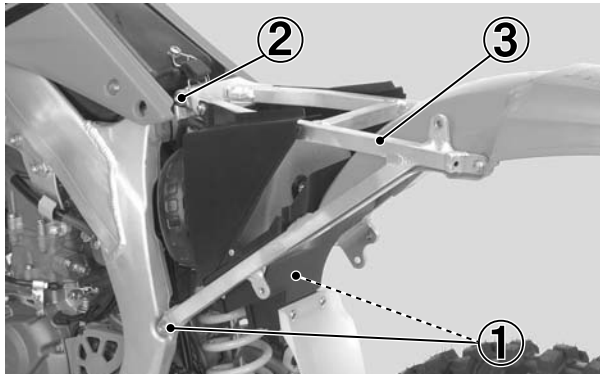

- (1) SUBFRAME MOUNTING A BOLTS
- (2) SUBFRAME MOUNTING B BOLT
- (3) SUBFRAME

Subframe Installation

1. Loosely attach the upper and lower ends of the subframe to the mainframe while connecting the air cleaner connecting tube to the carburetor. Then align the subframe with the rear wheel and tighten the subframe mounting B bolt and subframe mounting A bolts.

TORQUE:

B bolt: 22 lbf·ft (30 N·m, 3.1 kgf·m)

A bolt: 36 lbf·ft (49 N·m, 5.0 kgf·m)

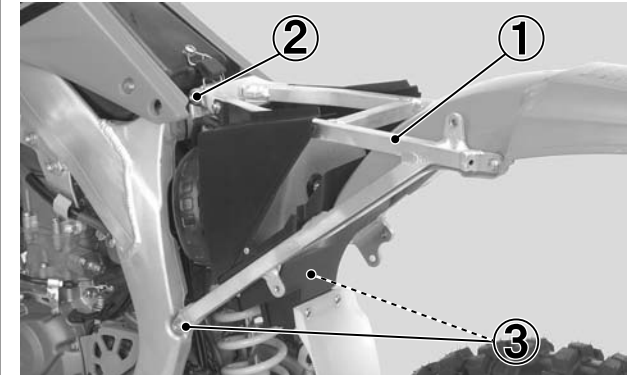

- (1) SUBFRAME
- (2) SUBFRAME MOUNTING B BOLT
- (3) SUBFRAME MOUNTING A BOLTS

4. SERVICE AND MAINTENANCE

2. Tighten the screw on the air cleaner connecting tube clamp.
3. Connect the crankcase breather tube.

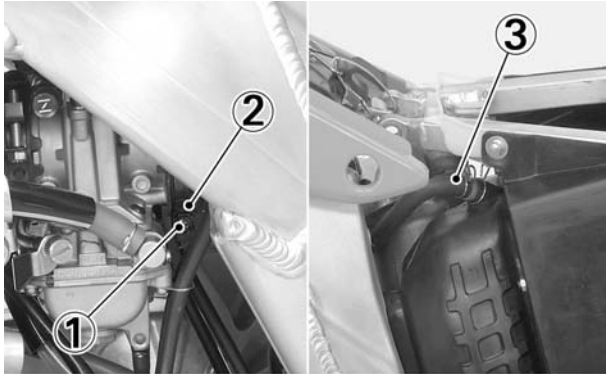

- (1) SCREW
 (2) AIR CLEANER CONNECTING TUBE CLAMP
 (3) CRANKCASE BREATHER TUBE

4. Remove the gasket.
5. Install the muffler clamp and new gasket to exhaust pipe.

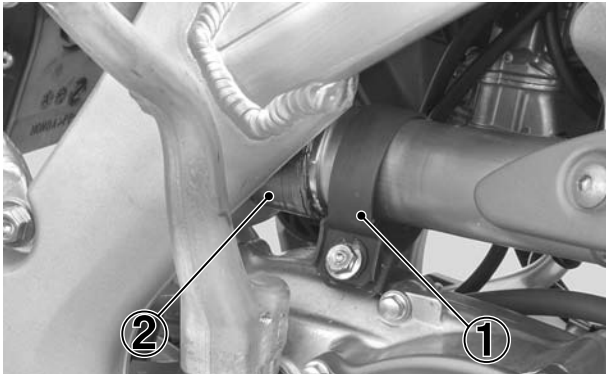

- (1) MUFFLER CLAMP (2) GASKET

6. Install the muffler.
7. Install the muffler clamp by aligning the tab of the muffler clamp with the cut-out of the muffler.

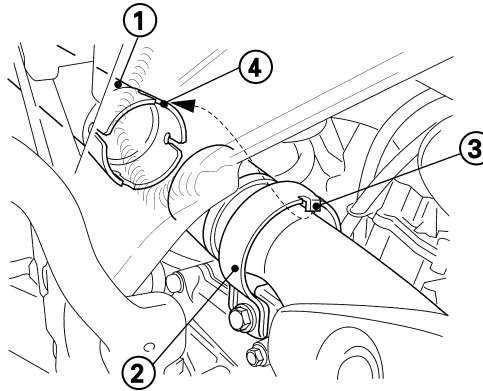

- (1) MUFFLER (2) MUFFLER CLAMP
 (3) TAB (4) CUT-OUT

8. Tighten the muffler B bolt and muffler A bolt.

TORQUE: 16 lbf·ft (22 N·m, 2.2 kgf·m)

9. Tighten the muffler clamp bolt.

TORQUE: 15 lbf·ft (21 N·m, 2.1 kgf·m)

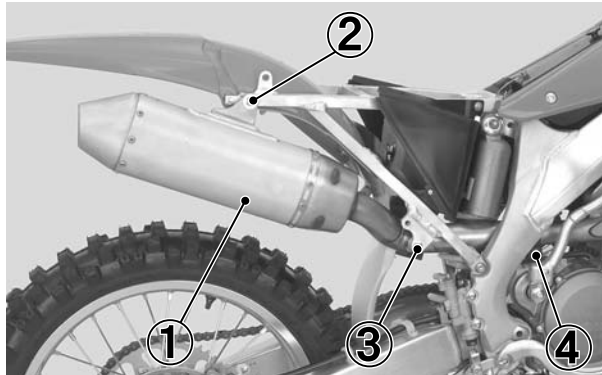

- (1) MUFFLER
 (2) MUFFLER B BOLT
 (3) MUFFLER A BOLT
 (4) MUFFLER CLAMP BOLT

10. Install the side covers, side cover bolts and collars.
11. Install the seat (page 17).

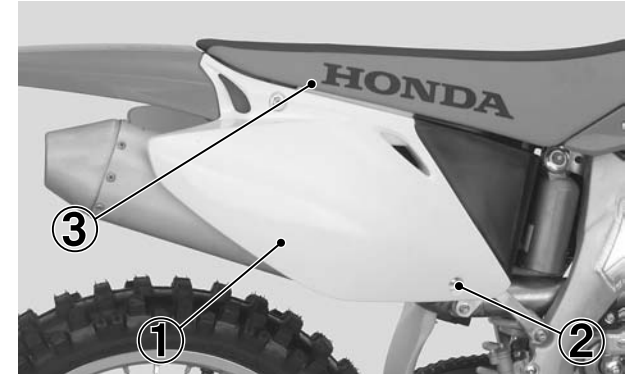

- (1) SIDE COVER
 (2) SIDE COVER BOLTS/COLLARS
 (3) SEAT

MAINTENANCE PROCEDURES

ENGINE OIL

Inspecting and Adding Engine Oil

1. Run the engine at idling for a few minutes, then shut it off.
2. Wait three minutes after shutting off the engine to allow the oil to properly distribute itself in the engine.
3. Support the CRF in an upright position on a level surface.
4. Check that the oil level is between the upper and lower level marks in the inspection window.
 - If the oil is at or near the upper level mark, you do not have to add oil.
 - If the oil is below or near the lower level mark, remove the engine oil filler cap and add the recommended oil until it reaches the upper level mark. (Do not overfill)Reinstall the engine oil filler cap.
Repeat steps 1–4.
5. Check for oil leaks.

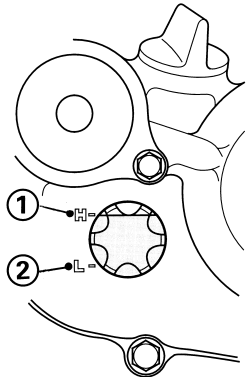

- (1) UPPER LEVEL MARK
- (2) LOWER LEVEL MARK
- (3) INSPECTION WINDOW
- (4) ENGINE OIL FILLER CAP

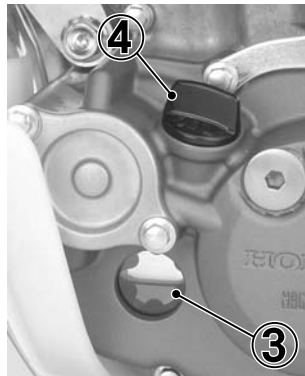

Replacing Engine Oil and Filter

1. Run the engine at idling for a few minutes, then shut it off.
2. Support the CRF in an upright position on a level surface.
3. Remove the engine oil filler cap from the left crankcase cover.
4. Place an oil drain pan under the engine to catch the oil. Then remove the engine oil drain bolt and sealing washer.
5. With the engine stop button pushed, repeat kickstarter operation approximately 5 times to drain the engine oil completely.
6. After the oil has drained, install the engine oil drain bolt with a new sealing washer.

TORQUE: 12 lbf·ft (16 N·m, 1.6 kgf·m)

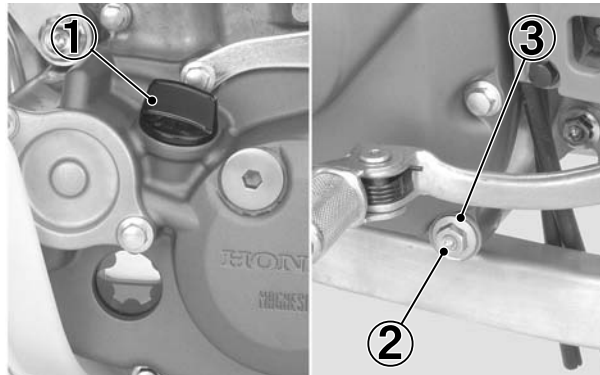

- (1) ENGINE OIL FILLER CAP
- (2) ENGINE OIL DRAIN BOLT
- (3) SEALING WASHER

7. It is recommended to replace the oil and filter every 6 races or about every 15.0 hours. However, if you replace only the oil before the recommended interval, see step 15 (page 22).

8. Remove the left engine guard bolt and left engine guard.

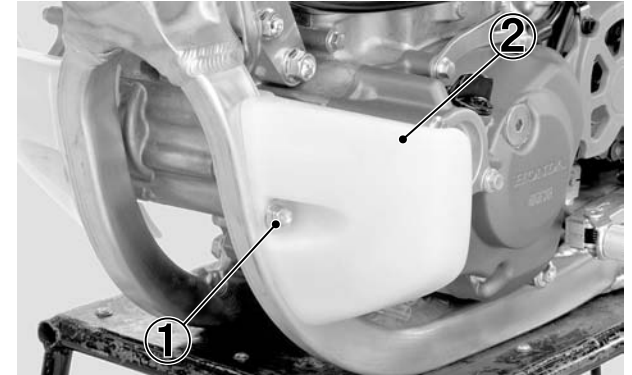

- (1) LEFT ENGINE GUARD BOLT
- (2) LEFT ENGINE GUARD

9. Remove the oil filter cover bolts and oil filter cover.
10. Remove the oil filter from the cover.
11. Check that the oil filter cover O-ring is in good condition.

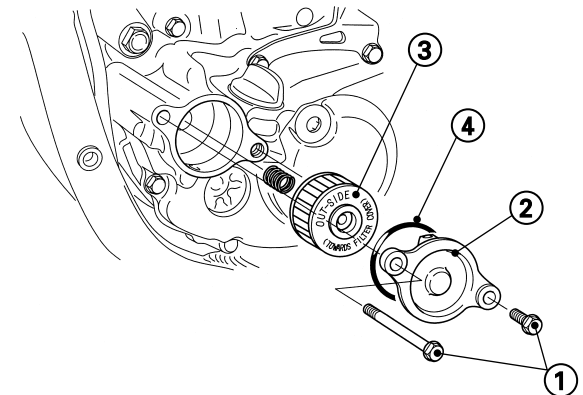

- (1) OIL FILTER COVER BOLTS
- (2) OIL FILTER COVER
- (3) OIL FILTER
- (4) OIL FILTER COVER O-RING

4. SERVICE AND MAINTENANCE

12. Apply grease to the seat face of spring.
13. Position the spring against the engine crankcase and install a new oil filter with the rubber seal facing out, away from the engine. You should see the "OUT-SIDE" mark on the filter body, near the seal. Use a new genuine Honda oil filter or a filter of equal quality specified for your model.

CAUTION:

- **If the oil filter is not installed properly, it will cause serious engine damage.**

14. Install the oil filter cover, then tighten the oil filter cover bolts.

TORQUE: 7 lbf·ft (10 N·m, 1.0 kgf·m)

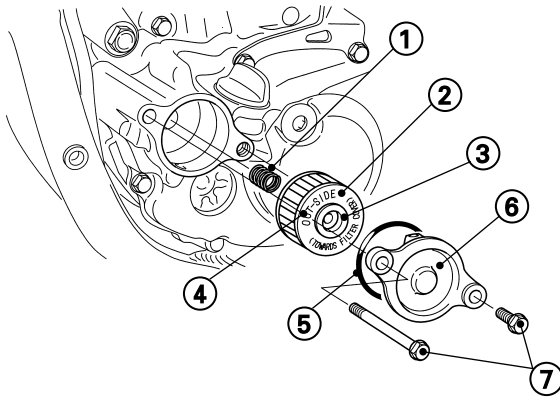

- (1) SPRING
- (2) OIL FILTER
- (3) RUBBER SEAL
- (4) OUT-SIDE MARK
- (5) O-RING
- (6) OIL FILTER COVER
- (7) OIL FILTER COVER BOLTS

15. Install the left engine guard and left engine guard bolt.

16. Fill the crankcase with the recommended oil.
capacity: 0.73 US qt (0.69 liter, 0.61 Imp qt) at oil and filter change
0.70 US qt (0.66 liter, 0.58 Imp qt) at oil change

17. Install the engine oil filler cap.

18. Check the engine oil level by following the steps in Inspecting and Adding Engine Oil (page 21).

Recommended Engine Oil

Use Pro Honda GN4, HP4 (without molybdenum additives) or HP4M (with molybdenum additives) 4-stroke oil, or an equivalent.*

| | |
|--------------------|---|
| API classification | SG or higher except oils labeled as energy conserving on the circular API service label |
| viscosity (weight) | SAE 10W-40 |
| JASO T 903 | MA or MB |

* Suggested oils are equal in performance to SJ oils that are not labeled as energy conserving on the circular API service label.

- Your CRF does not need oil additives. Use recommended oil.
- Do not use API SH or higher oils displaying a circular API "energy conserving" label on the container. They may affect lubrication.



NOT RECOMMENDED



OK

CAUTION:

- **Oil is a major factor affecting the performance and service life of the engine.**
Nondetergent, vegetable, or castor based racing oils are not recommended.

Other viscosities shown in the chart below may be used when the average temperature in your riding area is within the indicated range.

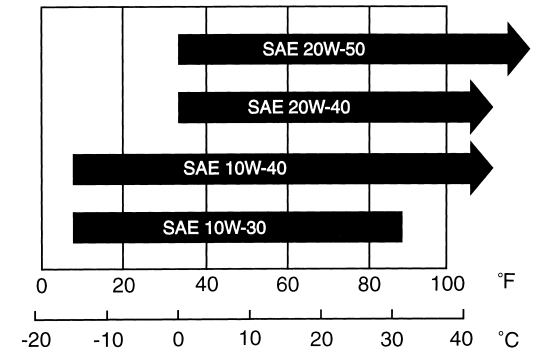

JASO T 903 standard

The JASO T 903 standard is an index to choose engine oils for 4-stroke motorcycle engines.

There are two classes: MA and MB.

Oil conforming to the standard has the following classification on the oil container.

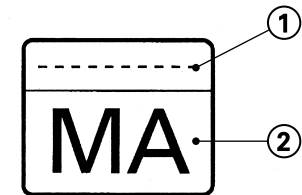

**PRODUCT MEETING JASO T 903
 COMPANY GUARANTEEING THIS MA PERFORMANCE:**

- (1) CODE NUMBER OF THE SALES COMPANY OF THE OIL
- (2) OIL CLASSIFICATION

TRANSMISSION OIL

Inspecting and Adding Transmission Oil

1. Run the engine at idling for a few minutes, then shut it off.
2. Wait three minutes after shutting off the engine to allow the oil to properly distribute itself in the clutch and transmission.
3. Support the CRF in an upright position on a level surface.
4. Remove the transmission oil filler cap and oil check bolt from the right crankcase cover. A small amount of oil should flow out of the oil check bolt hole. Allow any excess oil to flow out of the oil check bolt hole.
If no oil flows out of the oil check bolt hole, add oil slowly through the transmission oil filler hole until oil start to flow out of the oil check bolt hole. Install the oil check bolt and transmission oil filler cap. Repeat step 1–4.
5. After inspection the oil level or adding oil, tighten the oil check bolt and transmission oil filler cap securely.

TORQUE:

Oil Check Bolt: 7 lbf·ft (10 N·m, 1.0 kgf·m)

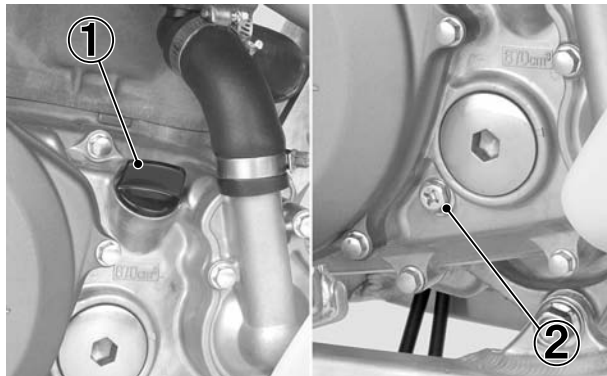

- (1) TRANSMISSION OIL FILLER CAP
(2) OIL CHECK BOLT

Replacing Transmission Oil

1. Run the engine for three minutes, then shut it off.
2. Support the CRF in an upright position on a level surface.
3. Remove the transmission oil filler cap from the right crankcase cover
4. Place an oil drain pan under the engine to catch the oil. Then remove the transmission oil drain bolt and sealing washer.
5. After the oil has drained, install the transmission oil drain bolt with a new sealing washer.

TORQUE: 16 lbf·ft (22 N·m, 2.2 kgf·m)

6. Fill the crankcase with recommended oil.
capacity: 0.62 US qt (0.59 liter, 0.52 Imp qt) at oil change
7. Check the transmission oil level by following the steps in Inspecting and Adding Transmission Oil (this page).

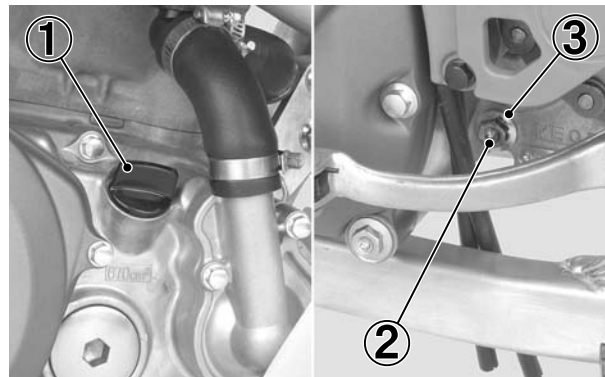

- (1) TRANSMISSION OIL FILLER CAP
(2) TRANSMISSION OIL DRAIN BOLT
(3) SEALING WASHER

Recommended Transmission Oil

Use Pro Honda HP Trans Oil, Pro Honda GN4 or HP4 (without molybdenum additives) 4-stroke oil, or an equivalent.*

4-stroke oil performance

| | |
|--------------------|---|
| API classification | SG or higher except oils labeled as energy conserving on the circular API service label |
| viscosity (weight) | SAE 10W-40 |
| JASO T 903 | MA |
| others | without friction modifiers as molybdenum additives |

* Suggested oils are equal in performance to SJ oils that are not labeled as energy conserving on the circular API service label.

- Your CRF does not need oil additives. Use recommended oil.
- Do not use oils with graphite or molybdenum additives. They may adversely affect clutch operation.
- Do not use API SH or higher oils displaying a circular API "energy conserving" label on the container. They may affect lubrication and clutch performance.



NOT RECOMMENDED



OK

CAUTION:

- **Oil is a major factor affecting the performance and service life of the transmission and clutch. Nondetergent, vegetable, or castor based racing oils are not recommended.**

4. SERVICE AND MAINTENANCE

Other viscosities shown in the chart below may be used when the average temperature in your riding area is with in the indicated range.

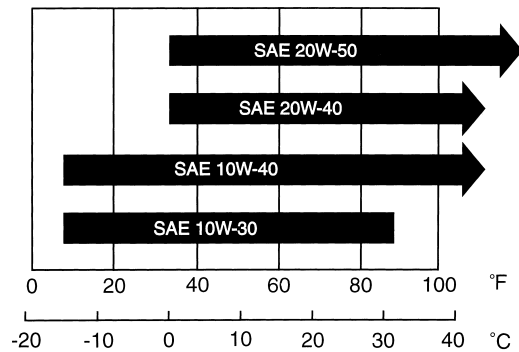

JASO T 903 standard

The JASO T 903 standard is an index to choose engine oils for 4-stroke motorcycle engines.

There are two classes: MA and MB.

Oil conforming to the standard has the following classification on the oil container.

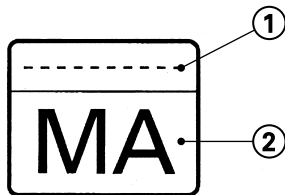

PRODUCT MEETING JASO T 903
COMPANY GUARANTEEING THIS MA PERFORMANCE:

- (1) CODE NUMBER OF THE SALES COMPANY OF THE OIL
- (2) OIL CLASSIFICATION

COOLANT

Coolant Recommendation

Use Pro Honda HP coolant or an equivalent high quality ethylene glycol based anti-freeze containing corrosion protection inhibitors specifically recommended for use in aluminum engines (See anti-freeze container label).

CAUTION:

- *Hard water or salt water is harmful to aluminum. The factory provides a 50/50 mix of anti-freeze and water in your CRF. This mixture is recommended for most operating temperatures and provides good corrosion protection. A higher concentration of anti-freeze decreases the cooling system performance and is recommended only when additional protection against freezing is needed. Using less than 40% anti-freeze will not provide proper cooling or corrosion protection.*
- *Using coolant with silicate inhibitors may cause premature wear of water pump seals or blockage of radiator passages. Using tap water may cause engine damage.*

Coolant Level

▲ WARNING

- *Never remove the radiator cap when the engine is hot. The coolant is under pressure and severe scalding could result.*
1. With the engine cold, remove the radiator cap and check coolant level. The coolant level is correct when it is at the bottom of the radiator filler neck.



(1) RADIATOR CAP

2. Add coolant up to the filler neck if the level is low.

NOTE :

- Inspect the coolant level before each outing. A coolant loss of 0.7 – 2.0 US oz (20 – 60 cm³, 0.7 – 2.1 Imp, oz) through the over flow tube is normal. If coolant loss is more than this, inspect the cooling system .

**Capacity: 1.18 US qt (1.12 liter, 0.99 Imp qt)
at disassembly
1.09 US qt (1.03 liter, 0.91 Imp qt)
at coolant change**

3. Install the radiator cap securely.

CAUTION:

- *If the radiator cap is not installed properly, it will cause excessive coolant loss and may result in overheating and engine damage.*

Cooling System Inspection

1. Check the cooling system for leaks (see the Honda Service Manual for troubleshooting of leaks).
2. Check water hoses for cracks, deterioration, and clamp bands for looseness.
3. Check the radiator mount for looseness.
4. Make sure the overflow tube is connected and not clogged.
5. Check the radiator fins for clogging.
6. Check the water leakage check hole below the water pump for leakage. Make sure the hole remains open. If water leaks through the check hole, the water pump seal is damaged. If oil leaks through the check hole, the transmission oil seal is damaged. See the Honda Service Manual or consult your authorized Honda dealer for replacing the water pump seal or the transmission oil seal. Both seals should be replaced at the same time.

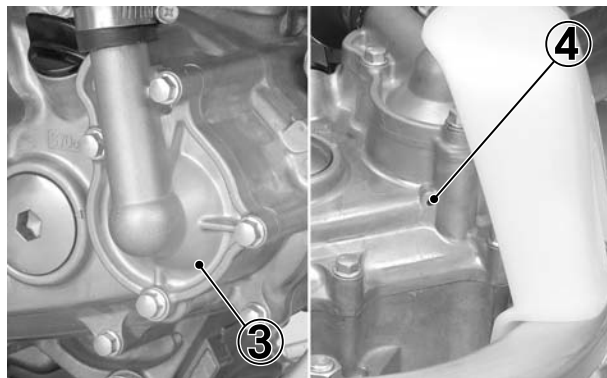
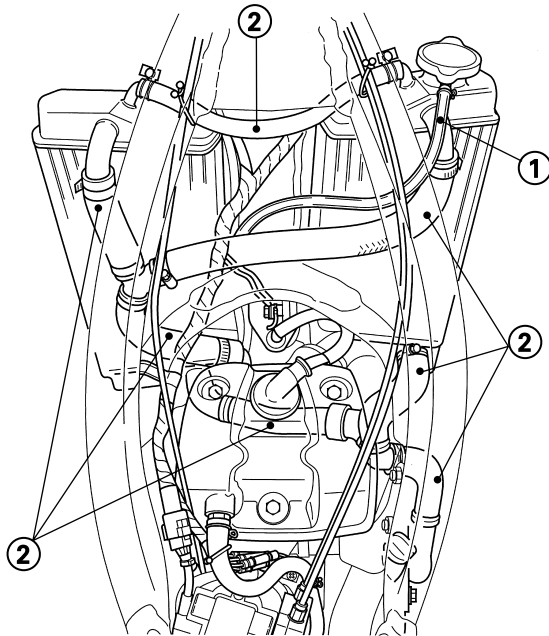

- (1) OVERFLOW TUBE
- (2) WATER HOSE
- (3) WATER PUMP COVER
- (4) WATER LEAKAGE CHECK HOLE

SPARK PLUG

Standard:

(NGK) IFR8H11
(DENSO) VK24PRZ11

For extended high speed riding:

(NGK) IFR9H11
(DENSO) VK27PRZ11

If replacing with any other brand of spark plug, be certain to select the correct reach and heat range. Before removing the spark plug, clean the spark plug area thoroughly to prevent dirt from entering the cylinder.

CAUTION:

- *The use of a spark plug of the incorrect reach or heat range can cause engine damage. The use of a non-resistor spark plug may cause ignition problems.*

This motorcycle uses spark plug that have an iridium tip in center electrode and a platinum tip in side electrode.

Be sure to observe the following when servicing the spark plug.

- Do not clean the spark plug. If an electrode is contaminated with accumulated objects or dirt, replace the spark plug with a new one.
- Use only a "wire-type feeler gauge" to check the spark plug if necessary. To prevent damaging the iridium tip of the center electrode and platinum tip of the side electrode, never use a leaf-type feeler gauge.

1. Remove the fuel tank (page 17).
2. Disconnect the spark plug cap.
3. Remove the spark plug.

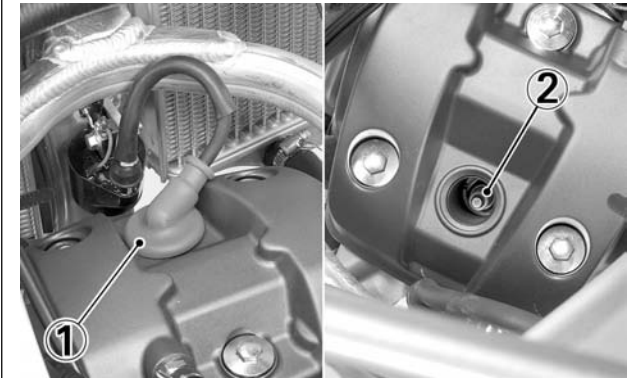

- (1) SPARK PLUG CAP
- (2) SPARK PLUG

4. Check the electrode for wear or deposits, the gasket for damage, and the insulator for cracks. Replace if you detect them.
5. Check the spark plug gap, using a wire-type feeler gauge. If the gap is out of specifications, replace the plug with a new one.
The recommended spark plug gap is:
0.039 – 0.043 in (1.0 – 1.1 mm)

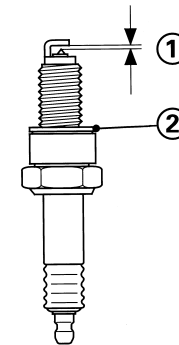

- (1) SPARK PLUG GAP
- (2) SEALING GASKET

4. SERVICE AND MAINTENANCE

- To obtain accurate spark plug readings, accelerate up to speed on a straightaway. Push the engine stop button and disengage the clutch by pulling the lever in.
Coast to a stop, then remove and inspect the spark plug. The porcelain insulator around the center electrode should appear tan or medium gray.

NOTE:

- If you're using a new plug, ride for at least ten minutes before taking a plug reading; a brand-new plug will not color initially.

If the electrodes appear burnt, or the insulator is white or light gray (lean) or the electrodes and insulator are black or fouled (rich), there is a problem elsewhere (page 70).

Check the carburetor, fuel system and ignition timing.

- Install the spark plug by hand until finger tight, then tighten with a wrench until the sealing gasket is compressed (1/2 turn to compress a new spark plug gasket, 1/8 – 1/4 turn to compress a spark plug with a used gasket).
- Connect the spark plug cap.
- Install the fuel tank (page 18)

IGNITION

A CDI (Capacitive Discharge Ignition) system is used on your CRF; consequently, routine ignition timing adjustment is unnecessary. If you want to check the ignition timing, refer to the Honda Service Manual.

ENGINE IDLE SPEED

Adjustment Procedure

- Turn the pilot screw in until it is lightly seated and record the number of turns. Turn the pilot screw out the same number of turns.

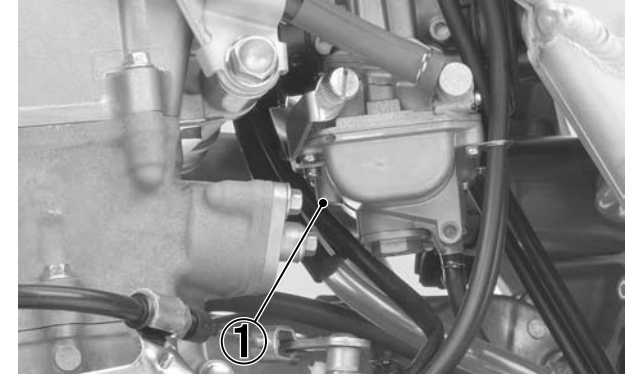

(1) PILOT SCREW

- If the engine is cold, start it and warm it up 3 minutes. Then shut it off.
- Connect a tachometer to the engine.
- Shift into neutral. Start the engine.
- Keep the motorcycle in an upright position.
- Adjust idle speed with the throttle stop screw.

Idle speed:

1,700 ± 100 rpm

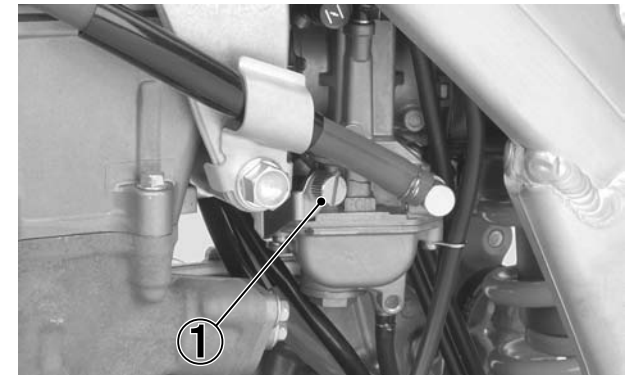

(1) THROTTLE STOP SCREW

CRANKCASE BREATHER

Service more frequently if your motorcycle is ridden in the rain or often at full throttle.

Service the breather if you can see deposits in the transparent section of the drain tube.

1. Remove the crankcase breather tube plug from the tube and drain deposits.
2. Reinstall the crankcase breather tube plug.

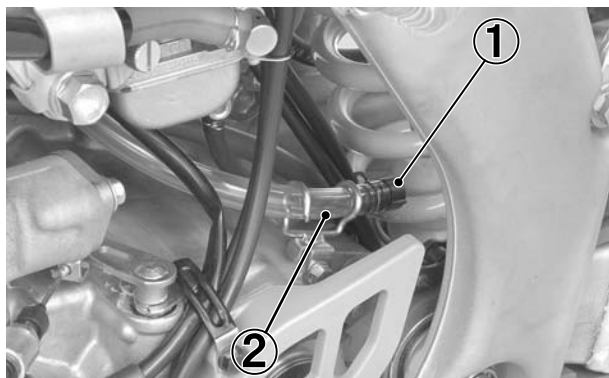

- (1) CRANKCASE BREATHER TUBE PLUG
(2) TUBE

AIR CLEANER

The air cleaner uses polyurethane inner and outer pieces which cannot be separated.

A dirty air cleaner will reduce engine power.

To clean the air cleaner:

1. Remove the seat (page 17).
2. Loosen the air cleaner retaining bolt.
3. Align the two access top tabs of the air cleaner and " " mark of the air cleaner housing by rotating the air cleaner counterclockwise.

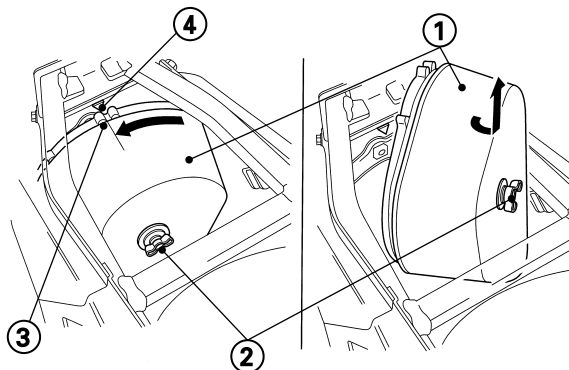

- (1) AIR CLEANER
(2) AIR CLEANER RETAINING BOLT
(3) TWO ACCESS TOP TABS
(4) " " MARK

4. Remove the air cleaner with the retaining bolt, keeping the two access top tabs up.

5. Remove the air cleaner from the air cleaner holder.

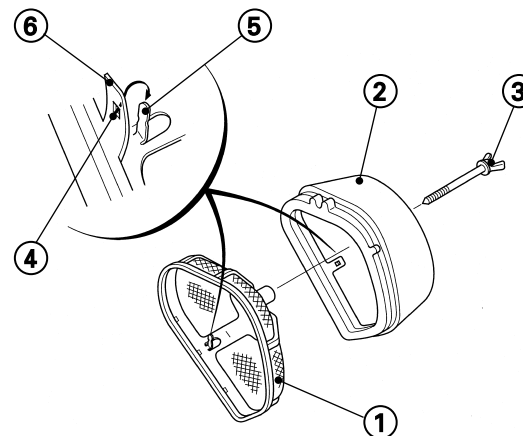

- (1) AIR CLEANER HOLDER (2) AIR CLEANER
(3) AIR CLEANER RETAINING BOLT
(4) HOLE
(5) HOLDER TAB (6) AIR CLEANER TAB

6. Wash the air cleaner in clean non-flammable cleaning solvent. Then wash in hot, soapy water, rinse well, and allow to dry thoroughly.
7. Clean the inside of the air cleaner housing.

▲WARNING

- **Never use gasoline or low flash point solvents for cleaning the air cleaner. A fire or explosion could result.**

NOTE :

- The air cleaner is made in two pieces: inner and outer, which cannot be separated.
8. Allow the air cleaner to dry thoroughly. After drying, soak the air cleaner in clean Pro Honda Foam Filter Oil or an equivalent air cleaner oil. Apply air cleaner oil to the entire surface, inner and outer, and rub it with both hands to saturate the air cleaner with oil. Squeeze out excess oil.
 9. Apply a thin coat of white lithium grease to the sealing surface.
 10. Assemble the air cleaner and holder. Install the tab of the holder in the hole of the air cleaner tab, and the air cleaner retaining bolt through the assembly.

4. SERVICE AND MAINTENANCE

11. Install the assembly into the air cleaner housing keeping the two access top tabs up.
12. Carefully position the sealing flange of the element to prevent dirt intrusion.
13. Align the set tab of the air cleaner with the " " mark of the air cleaner housing by rotating the air cleaner clockwise. Tighten the retaining bolt securely.

CAUTION:

- *If the air cleaner assembly is not installed correctly, dirt and dust may enter the engine resulting in rapid wear of the piston rings and cylinder.*

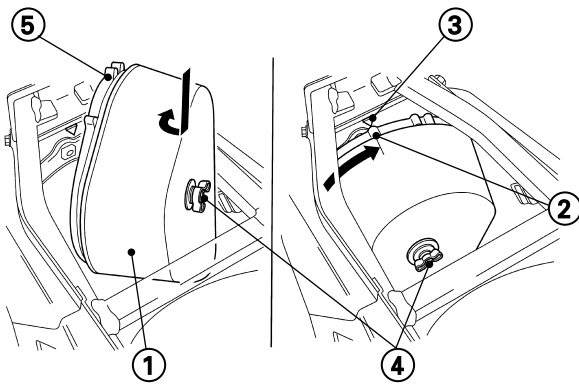

- (1) AIR CLEANER
 (2) SET TAB
 (3) " " MARK
 (4) RETAINING BOLT
 (5) TWO ACCESS TOP TABS

CLUTCH

Operation

1. Check for smooth clutch lever operation. Lubricate the clutch lever pivot or clutch cable if operation is not smooth.
2. Check the clutch cable for deterioration, kinks or damage.

Clutch Disc/Plate Removal

Drain the transmission oil (page 23).

Remove the rear brake pedal by removing its pivot bolt.

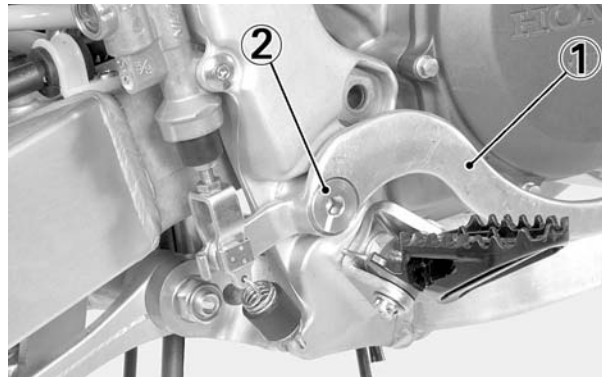

- (1) REAR BRAKE PEDAL (2) PIVOT BOLT

Remove the six clutch cover bolts and cover.



- (1) CLUTCH COVER BOLTS
 (2) CLUTCH COVER

Remove the six clutch spring bolts and clutch springs.

NOTE:

- Loosen the bolts in a crisscross pattern in 2 or 3 progressive steps.

Remove the clutch pressure plate.



- (1) CLUTCH SPRING BOLT
 (2) CLUTCH PRESSURE PLATE

Remove the clutch lifter and clutch lifter rod.

Remove the eight clutch discs and seven clutch plates.

NOTE:

- Turn the lifter bearing plate of the clutch lifter bearing with your finger. The bearing plate should turn smoothly and quietly. Discard the clutch lifter if the bearing plate does not turn smoothly.



- (1) CLUTCH LIFTER (2) CLUTCH LIFTER ROD
 (3) CLUTCH PLATES AND DISCS

Clutch Spring

The clutch springs have sky blue paint. Measure each clutch spring's free length.

SERVICE LIMIT: 1.76 in (43.7 mm)

Replace the clutch springs as a set if any one of them is beyond the service limit or if the clutch plates have been burnt/heat discolored.

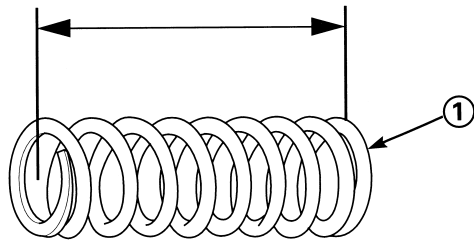

(1) CLUTCH SPRING

Clutch Disc

Replace the clutch discs if they show signs of scoring or discoloration. Measure the thickness of each clutch disc.

SERVICE LIMIT: 0.112 in (2.85 mm)

NOTE:

- Replace the clutch discs and clutch plates as an assembly.

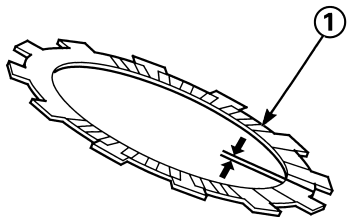

(1) CLUTCH DISC

Clutch Disc/Plate Installation

Coat the clutch plates with transmission oil. Install the six clutch discs which has yellow paint on the tab, two no painted discs and seven clutch plates alternately, starting with a disc. The two no painted discs should be placed onto each end.

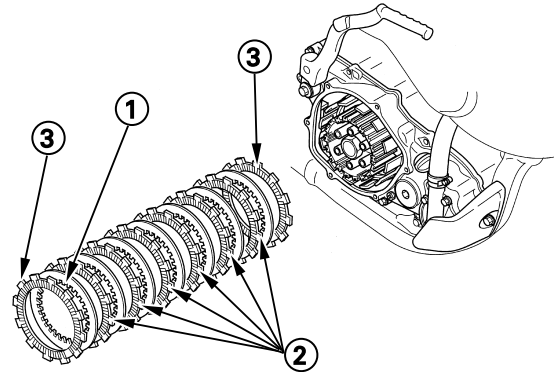

(1) CLUTCH PLATES (2) YELLOW PAINTED DISCS
(3) NO PAINTED DISCS

Apply grease to the clutch lifter rod. Insert the clutch lifter rod into the mainshaft. Install the clutch lifter onto the rod.



(1) CLUTCH LIFTER ROD (2) CLUTCH LIFTER

Install the clutch pressure plate. Install the six clutch springs and bolts. Tighten the bolts in a crisscross pattern in 2 or 3 steps.

TORQUE: 9 lbf·ft (12 N·m, 1.2 kgf·m)



(1) CLUTCH PRESSURE PLATE
(2) CLUTCH SPRING BOLTS

Install a new O-ring in the groove in the clutch cover. Install the cover by tightening the six cover bolts.

TORQUE: 7 lbf·ft (10 N·m, 1.0 kgf·m)

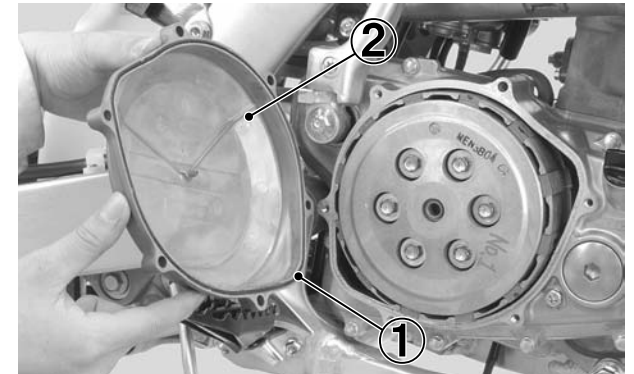

(1) O-RING (2) CLUTCH COVER

4. SERVICE AND MAINTENANCE

Connect the brake pedal return spring if it was removed.

Lubricate the rear brake pedal pivot and pivot bolt and tighten the pivot bolt.

TORQUE: 20 lbf·ft (26 N·m, 2.7 kgf·m)

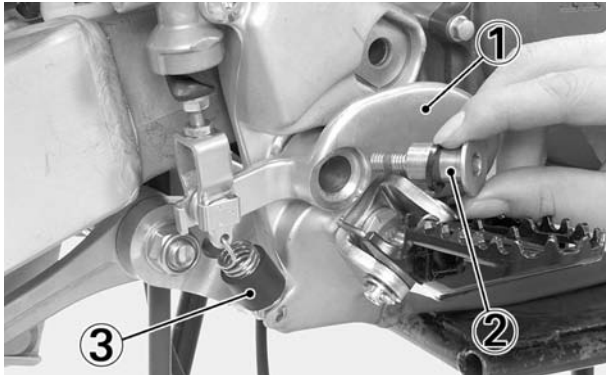

(1) BRAKE PEDAL (2) PIVOT BOLT
(3) RETURN SPRING

Add the transmission oil (page 23).

VALVE

Cylinder Head Cover Removal

NOTE:

- Before inspection, clean the engine thoroughly to keep dirt from entering the engine.

Remove the seat (page 17).
Remove the fuel tank (page 17).
Disconnect the breather tube and spark plug cap.

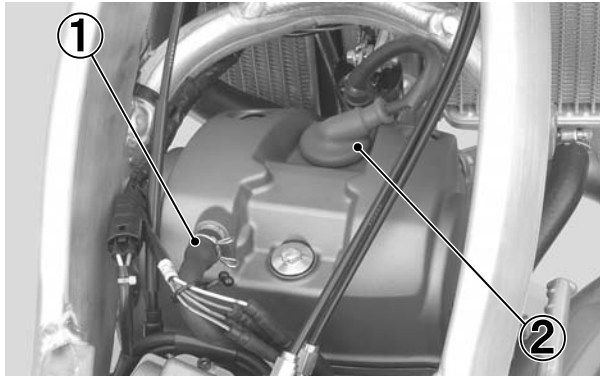

(1) BREATHER TUBE (2) SPARK PLUG CAP

Remove the cylinder head cover A bolt, cylinder head cover B bolts and cylinder head cover.

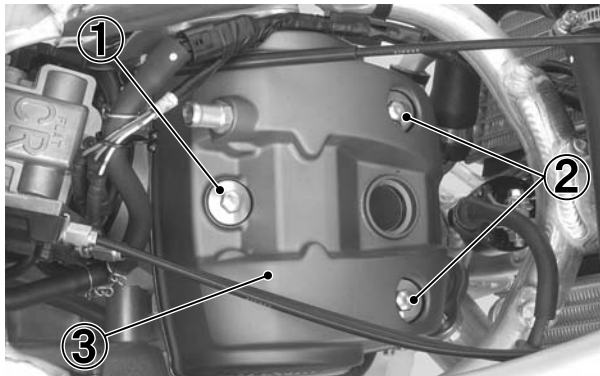

(1) CYLINDER HEAD COVER A BOLT
(2) CYLINDER HEAD COVER B BOLTS
(3) CYLINDER HEAD COVER

Positioning At Top Dead Center On The Compression Stroke.

Remove the crankshaft hole cap.

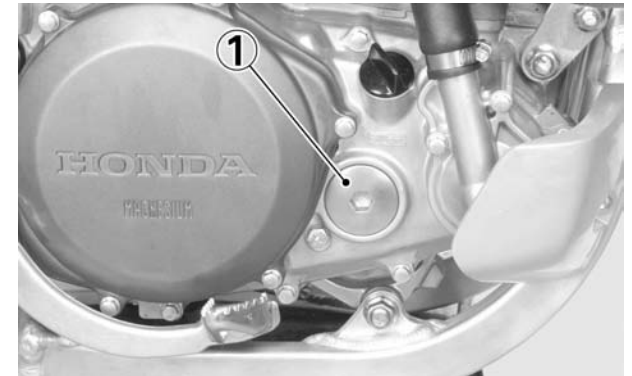

(1) CRANKSHAFT HOLE CAP

Remove the spark plug.

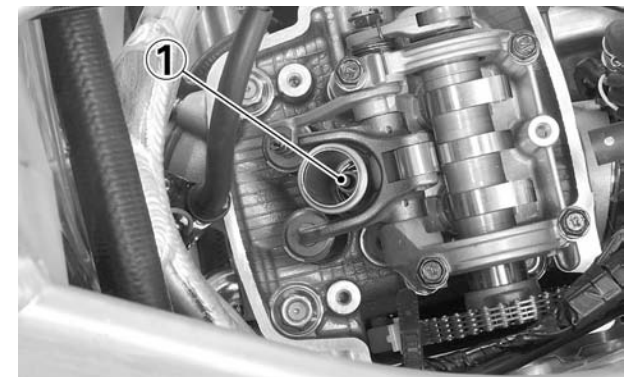

(1) SPARK PLUG

Rotate the crankshaft by turning the primary drive gear lock bolt (crankshaft) clockwise until aligning the "T" mark on the primary drive gear with the index mark on the right crankcase cover. In this position, the piston may either be on the compression or exhaust stroke. If the crankshaft passed the "T" mark, rotate the primary drive gear lock bolt clockwise again and align "T" mark with the index mark.

The inspection must be made when the piston is at top of the compression stroke when both the intake and exhaust valves are closed.

This condition can be determined by moving the exhaust rocker arm. If it is free, it is an indication that the valves are closed and that the piston is on the compression stroke. If it is tight and the valves are open, rotate the primary drive gear lock bolt 360° and realign the "T" mark to the index mark.

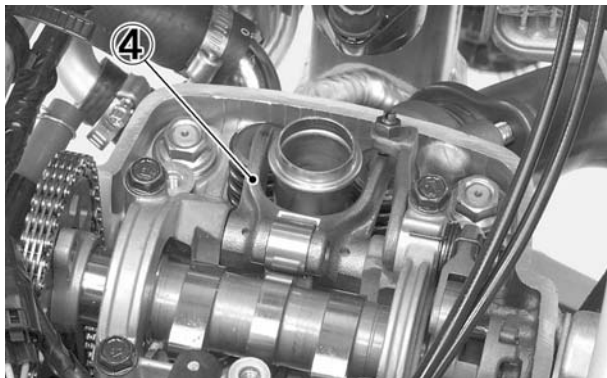
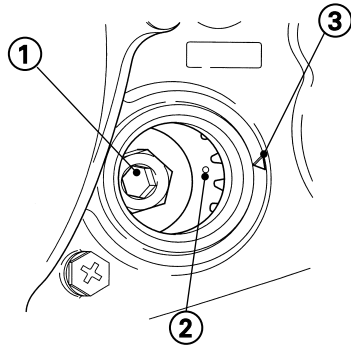

- (1) PRIMARY DRIVE GEAR LOCK BOLT
- (2) "T" MARK
- (3) INDEX MARK
- (4) EXHAUST ROCKER ARM

Valve Clearance And Decompressor Arm Clearance Inspection

Measure the intake valve clearance by inserting a feeler gauge between the valve lifter and cam lobe.

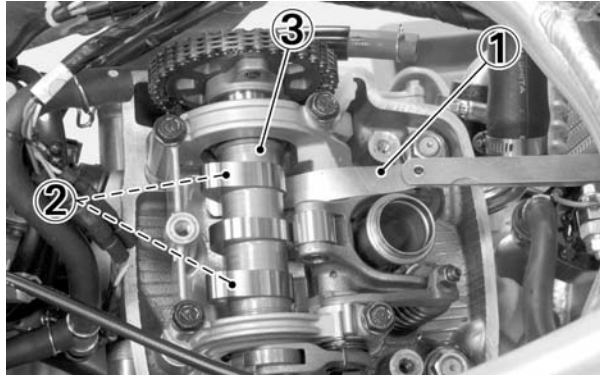

- (1) FEELER GAUGE
- (2) INTAKE VALVES, VALVE LIFTERS
- (3) CAMSHAFT

Measure the exhaust valve clearance by inserting a feeler gauge between the exhaust rocker arm and shim.

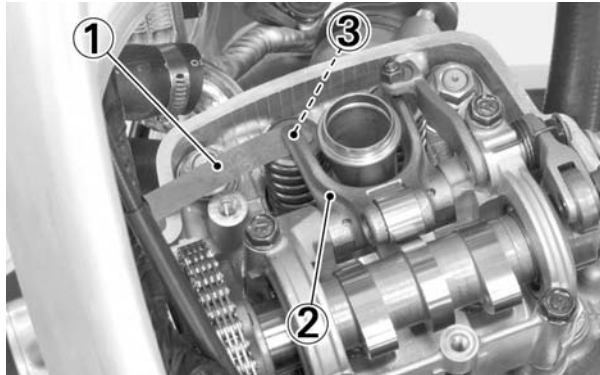

- (1) FEELER GAUGE
- (2) EXHAUST ROCKER ARM
- (3) EXHAUST VALVE SHIM

VALVE CLEARANCES:

IN: 0.006 ± 0.001 in (0.16 ± 0.03 mm)
 EX: 0.011 ± 0.001 in (0.28 ± 0.03 mm)

If intake valve clearance and exhaust valve clearance need adjustment, see Camshaft Holder Assembly Removal (page 32) and select the collect shim in each valve.

Measure the decompressor arm clearance by inserting a feeler gauge between the decompressor arm adjusting screw and right side rocker arm.

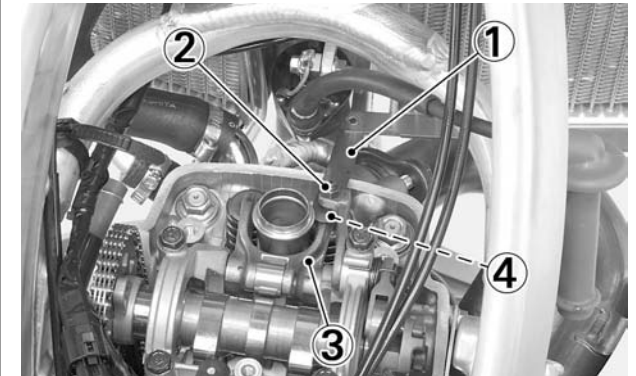

- (1) FEELER GAUGE
- (2) DECOMPRESSOR ARM ADJUSTING SCREW
- (3) RIGHT SIDE ROCKER ARM
- (4) RIGHT EXHAUST VALVE

DECOMPRESSOR CLEARANCE:

RIGHT EXHAUST VALVE CLEARANCE

+
 0.014 in (0.35 mm)

ex)

If measured right exhaust valve clearance is 0.011 in (0.28 mm), decompressor clearance is;

0.011 in (0.28 mm) + 0.014 in (0.35 mm) = 0.025 in (0.63 mm)

If only decompressor arm clearance needs adjustment, see Decompressor Arm Clearance Adjustment (page 37).

If intake valve clearance, exhaust valve clearance and decompressor arm clearance don't need adjustment, see Spark Plug Installation (Page 38).

4. SERVICE AND MAINTENANCE

Cam Shaft Holder Assembly Removal

Record the intake valve clearance, exhaust valve clearance and decompressor arm clearance.
Loosen a cam sprocket bolt.
Rotate the primary drive gear lock bolt (crankshaft) clockwise one turn and loosen the other sprocket bolt.



(1) CAM SPROCKET BOLTS

Remove the cam chain tensioner lifter cover bolt and sealing washer.

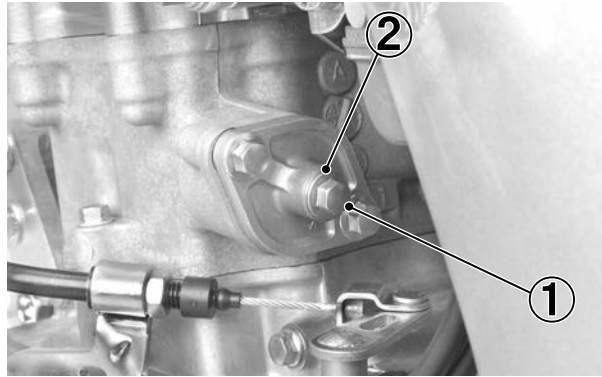

(1) CAM CHAIN TENSIONER LIFTER COVER BOLT
(2) SEALING WASHER

Make a tensioner shaft stopper tool out of a thin piece of steel (0.8 mm thick) using the diagram.

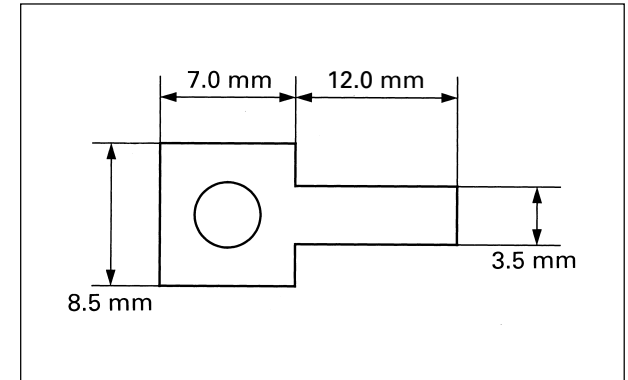

Turn the tensioner shaft clockwise with the stopper tool until it stops, in order to retract the tensioner fully.
Then insert the stopper tool fully to hold the stopper in the fully retracted position.

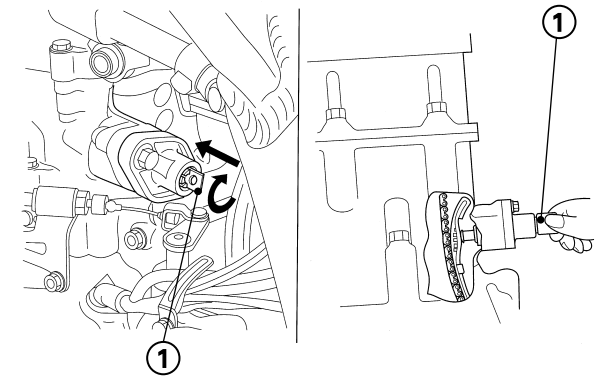

(1) STOPPER TOOL

Remove the cam sprocket bolt.
 Rotate the primary drive gear lock bolt (crankshaft) clockwise one turn and remove the other sprocket bolt and cam sprocket. Then attach a piece of wire to the cam chain to prevent it from falling into the crankcase.

CAUTION:

- **Do not let the bolts, sprocket and cam chain fall into the crankcase.**

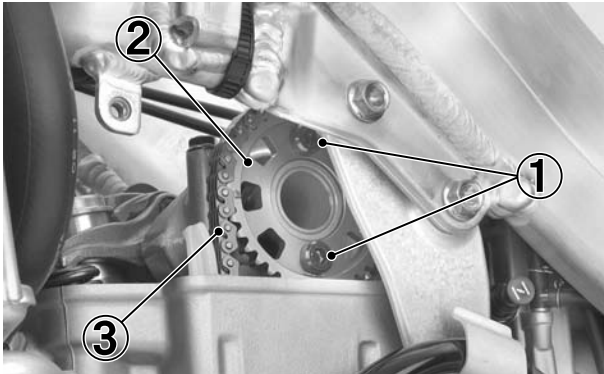

(1) CAM SPROCKET BOLTS
 (2) CAM SPROCKET
 (3) CAM CHAIN

Remove the camshaft holder assembly bolts, camshaft holder assembly, intake valve lifters and shims.

As you remove the camshaft holder assembly, the intake valve lifter and the intake valve shim may be sticking in the camshaft holder assembly.

NOTE:

- Loosen the camshaft holder assembly bolts in a criss-cross pattern in 2 or 3 steps.
- Keep the intake valve lifters and the shims so as to allow identification of the originally installed location such as intake or exhaust, right or left.

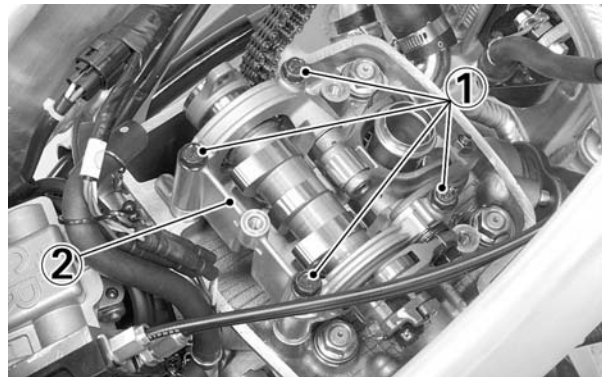

(1) CAMSHAFT HOLDER ASSEMBLY BOLTS
 (2) CAMSHAFT HOLDER ASSEMBLY

CAUTION:

- **Do not let the valve lifters and shims fall into the crankcase.**

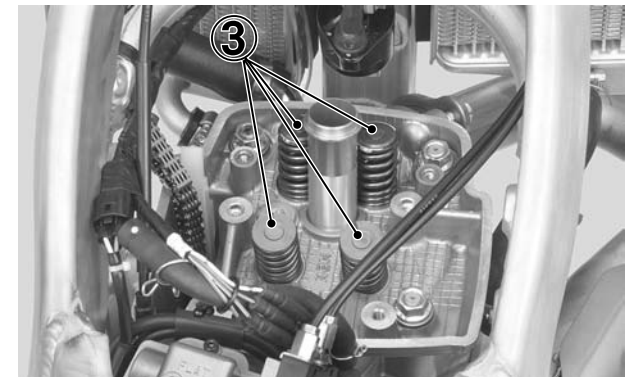
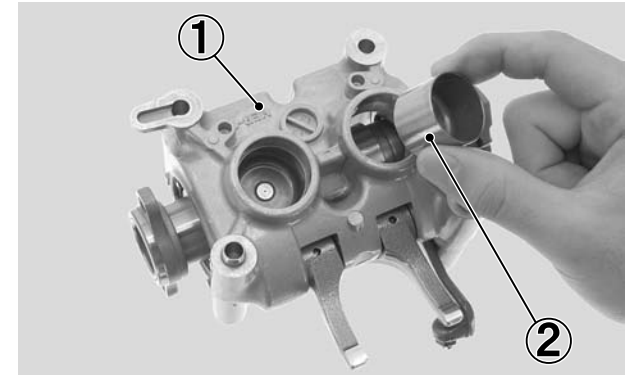

(1) CAMSHAFT HOLDER ASSEMBLY
 (2) VALVE LIFTERS
 (3) SHIMS

Remove the valve shims.

4. SERVICE AND MAINTENANCE

Shim Selection

Clean the valve shim contact area in the valve lifter with compressed air.



(1) VALVE LIFTER

Measure the shim thickness and record it.

NOTE:

- Seventy-three different thickness shims are available from the thinnest (1.200 mm thickness) shim to the thickest (3.000 mm thickness) in intervals of 0.025 mm.

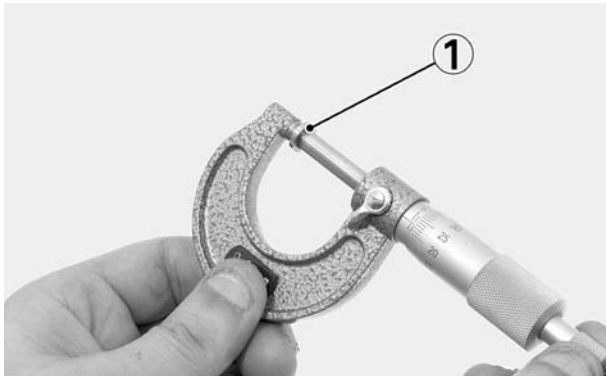

(1) SHIM

Calculate the new shim thickness using the equation below.

$$A = (B - C) + D$$

- A: New shim thickness
B: Recorded valve clearance
C: Specified valve clearance
D: Old shim thickness

NOTE:

- Make sure of the correct shim thickness by measuring the shim with the micrometer.
- Reface the intake valve seat if carbon deposits result in a calculated dimension of over 2.450 mm. Reface the exhaust valve seat if carbon deposits result in a calculated dimension of over 3.000 mm.



1.80 mm



1.825 mm



1.85 mm



1.875 mm

Camshaft Holder Assembly Installation

Install the newly selected shims on the valve retainers.

CAUTION:

- Do not let the shims fall into the crankcase.

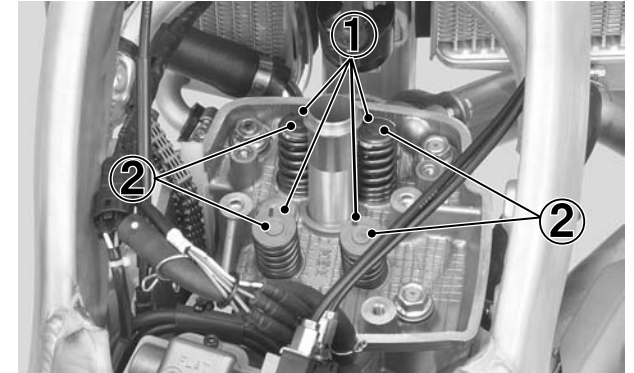

(1) VALVE RETAINERS (2) SHIMS

Apply molybdenum disulfide oil (a mixture of 1/2 engine oil and 1/2 molybdenum disulfide grease (containing more than 3% molybdenum disulfide additive)) to camshaft and outer surface of the each valve lifters.

Install the valve lifters into cam shaft holder assembly.

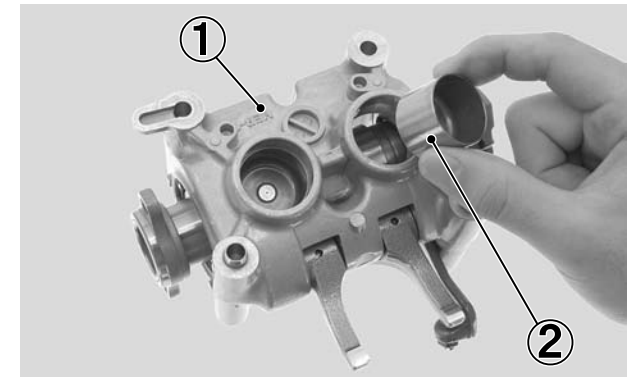

(1) CAM SHAFT HOLDER ASSEMBLY
(2) VALVE LIFTERS

Install the cam shaft holder assembly onto the cylinder head with the intake cam lobes facing up as illustrated below.

Apply the oil to the camshaft holder assembly bolt threads and seating surface.

Install the camshaft holder assembly bolts.

TORQUE: 10 lbf·ft (14 N·m, 1.4 kgf·m)

NOTE:

- Tighten the camshaft holder assembly bolts in a criss-cross pattern in 2 or 3 steps.

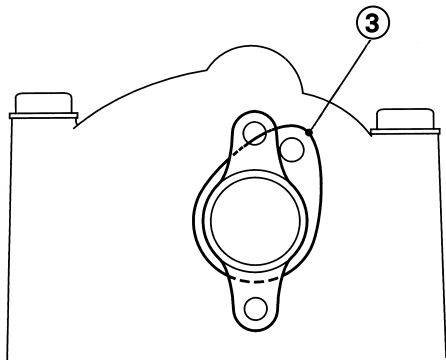
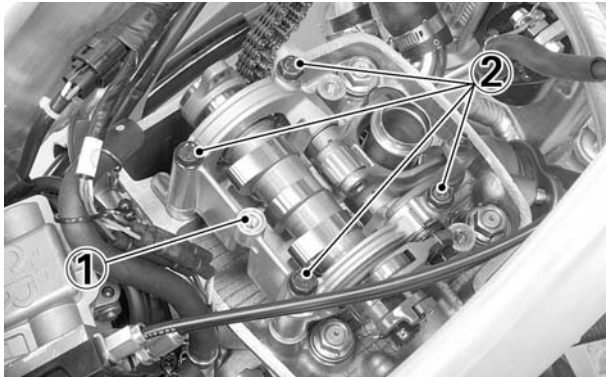

- (1) CAMSHAFT HOLDER ASSEMBLY
- (2) CAMSHAFT HOLDER ASSEMBLY BOLTS
- (3) INTAKE CAM LOBES

Insert the feeler gauge between the intake valve lifter and cam lobe.

If the feeler gauge cannot be inserted, the shim is caught between the valve lifter and the valve retainer. Remove the camshaft holder assembly, place the shim correctly, and reinstall the camshaft holder assembly.

Rotate the primary drive gear lock bolt (crankshaft) clockwise and align the "T" mark with the index mark.

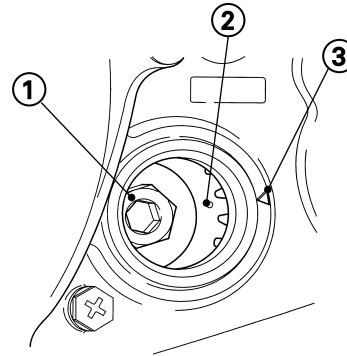

- (1) PRIMARY DRIVE GEAR LOCK BOLT
- (2) "T" MARK
- (3) INDEX MARK

Place the cam sprocket and align the timing mark on the cam sprocket with the mark on the camshaft holder assembly.

Install the cam chain over the sprocket without rotating the sprocket.

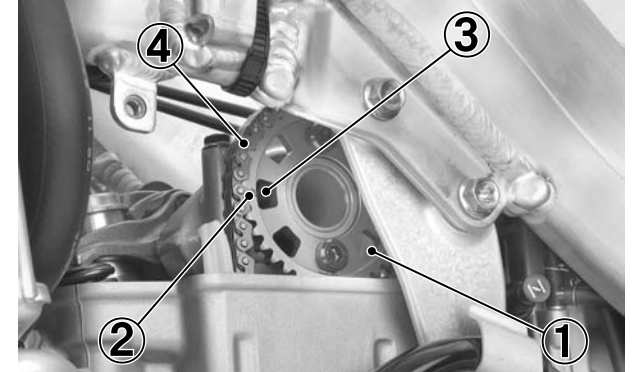

- (1) CAM SPROCKET
- (2) TIMING MARK
- (3) MARK
- (4) CAM CHAIN

4. SERVICE AND MAINTENANCE

Clean and apply a locking agent to the cam sprocket bolt threads (coating width: 0.26 in (6.5 mm) from tip). Position the cam sprocket onto the shoulder of the camshaft and install a cam sprocket bolt. Rotate the primary drive gear lock bolt (crankshaft) clockwise one turn and install the other sprocket bolt.

CAUTION:

- **Do not let the bolts and sprocket fall into the crankcase.**



(1) CAM SPROCKET BOLTS
(2) CAM SPROCKET

Remove the stopper tool from the cam chain tensioner lifter.

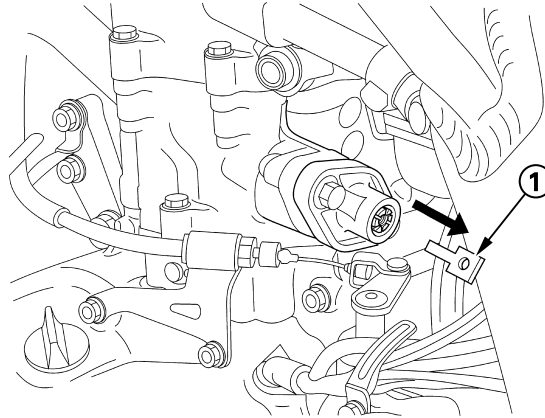

(1) STOPPER TOOL

Rotate the primary drive gear lock bolt (crankshaft) clockwise two turns and align the "T" mark with the index mark. Make sure that the timing marks on the sprocket align with the mark on the camshaft holder assembly.

If the timing mark doesn't align with the mark, remove the cam sprocket. Then realign the valve timing.

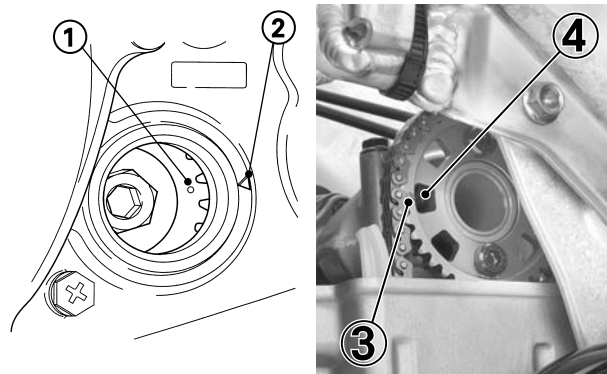

(1) "T" MARK
(2) INDEX MARK
(3) TIMING MARK
(4) MARK

Tighten the cam sprocket bolt, then tighten the other sprocket bolt.

TORQUE: 14 lbf·ft (20 N·m, 2.0 kgf·m)



(1) CAM SPROCKET BOLTS

Rotate the primary driver gear lock bolt (crankshaft) clockwise and align the "T" mark with the index mark. If the exhaust rocker arm is not free, rotate the primary drive gear lock bolt (crankshaft) clockwise one turn and realign the "T" mark to the index mark.

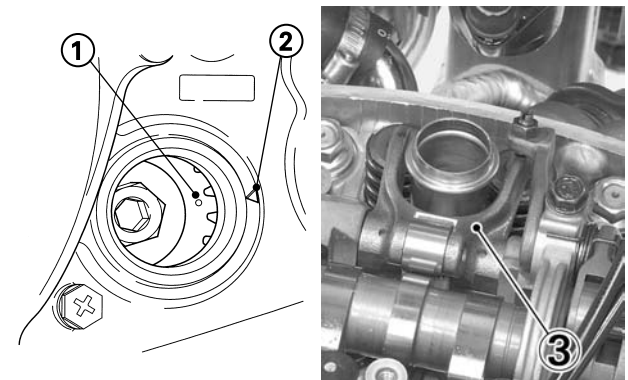

(1) "T" MARK
(2) INDEX MARK
(3) EXHAUST ROCKER ARM

Measure the intake valve clearance and exhaust valve clearance.

VALVE CLEARANCES:

IN: 0.006 ± 0.001 in (0.16 ± 0.03 mm)

EX: 0.011 ± 0.001 in (0.28 ± 0.03 mm)

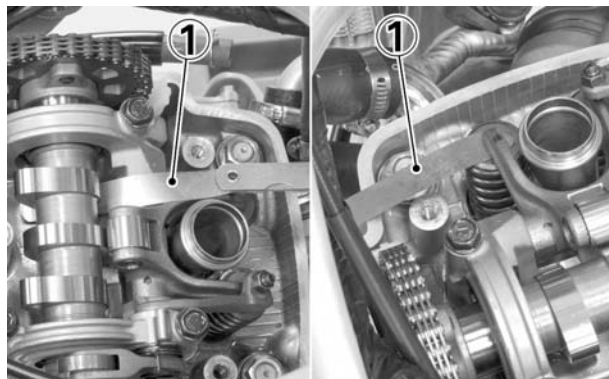

(1) FEELER GAUGE

Install the new sealing washer and cam chain tensioner lifter cover bolt.

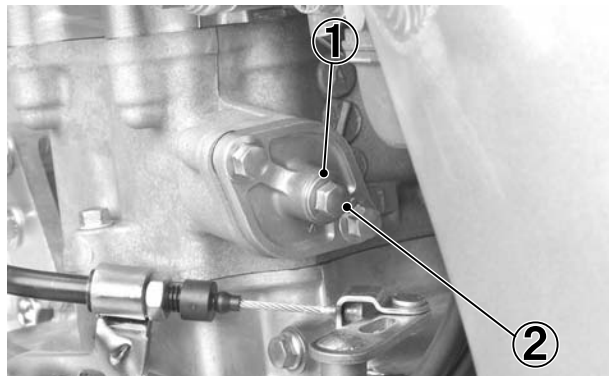

(1) SEALING WASHER
(2) CAM CHAIN TENSIONER LIFTER COVER BOLT

Measure the decompressor arm clearance by inserting a feeler gauge between the decompressor arm adjusting screw and right side rocker arm.

DECOMPRESSOR CLEARANCE:

RIGHT EXHAUST VALVE CLEARANCE

$$+ \\ 0.014 \text{ in (0.35 mm)}$$

ex)

If measured right exhaust valve clearance is 0.011 in (0.28 mm), decompressor clearance is;

$$0.011 \text{ in (0.28 mm)} + 0.014 \text{ in (0.35 mm)} = 0.025 \text{ in (0.63 mm)}$$

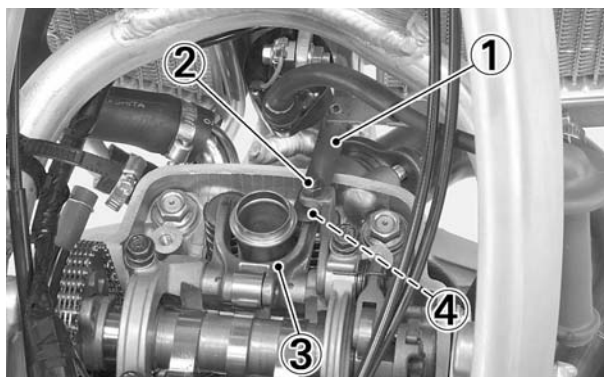

(1) FEELER GAUGE
(2) DECOMPRESSOR ARM ADJUSTING SCREW
(3) EXHAUST ROCKER ARM
(4) RIGHT EXHAUST VALVE

If decompressor arm clearance needs adjustment, see Decompressor Arm Clearance Adjustment (this page).

Decompressor Arm Clearance Adjustment

Make sure that the piston is at top dead center on the compression stroke (page 30).

Measure the right exhaust valve clearance by inserting a feeler gauge between the right side rocker arm and shim.

VALVE CLEARANCE:

EX: 0.011 ± 0.001 in (0.28 ± 0.03 mm)

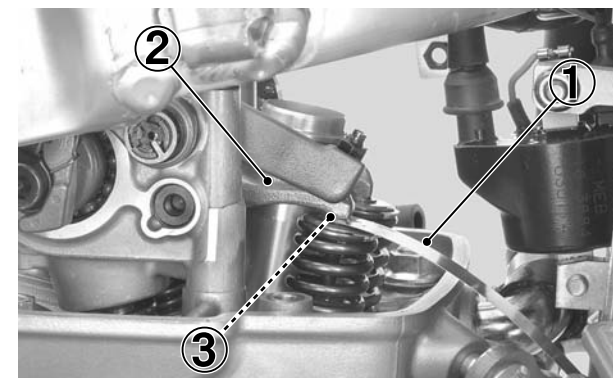

(1) FEELER GAUGE
(2) EXHAUST ROCKER ARM
(3) SHIM

Pull out the feeler gauge between the right side rocker arm and shim.

4. SERVICE AND MAINTENANCE

Loosen the lock nut and adjusting screw. Insert the feeler gauge (right exhaust valve clearance + 0.014 in (0.35 mm)); see page 31) between the adjusting screw and right side rocker arm. Turn the adjusting screw until there is a slight drag on the feeler gauge. Hold the adjusting screw and tighten the lock nut.

TORQUE: 7 lbf·ft (10 N·m, 1.0 kgf·m)

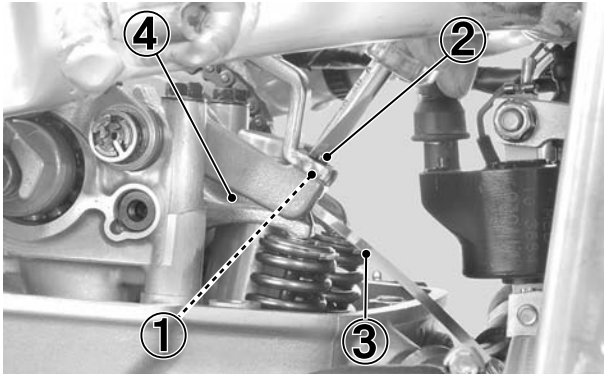

- (1) LOCK NUT
(2) ADJUSTING SCREW
(3) FEELER GAUGE
(4) RIGHT SIDE ROCKER ARM

Recheck the clearance between the adjusting screw and right side rocker arm.

DECOMPRESSOR CLEARANCE:
RIGHT EXHAUST VALVE CLEARANCE
+
0.014 in (0.35 mm)

ex)
If measured right exhaust valve clearance is 0.011 in (0.28 mm), decompressor clearance is;

0.011 in (0.28 mm) + 0.014 in (0.35 mm) = 0.025 in (0.63 mm)

Spark Plug Installation

Install the spark plug by hand until finger tight, then tighten with a spark plug wrench until the sealing gasket is compressed (1/2 turn to compress a new spark plug gasket, 1/8 – 1/4 turn to compress a spark plug with a used gasket).

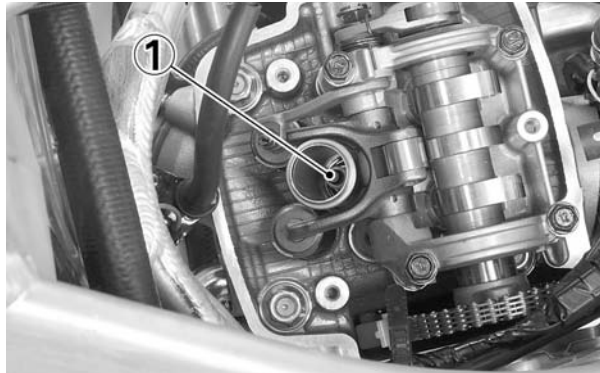

- (1) SPARK PLUG

Crankshaft Hole Cap Installation

Coat a new O-ring with grease and install it onto the crankshaft hole cap. Apply grease to the crankshaft hole cap threads. Install and tighten the crankshaft hole cap.

TORQUE: 11 lbf·ft (15 N·m, 1.5 kgf·m)

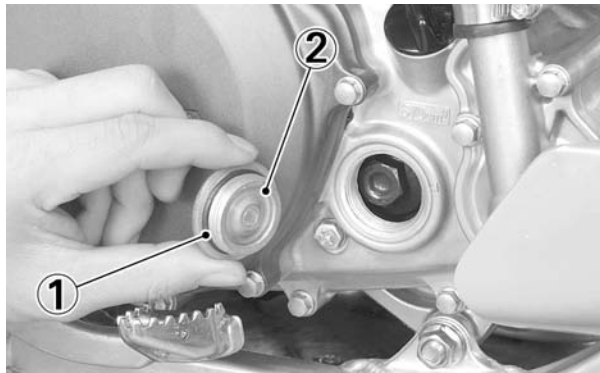

- (1) O-RING
(2) CRANKSHAFT HOLE CAP

Cylinder Head Cover Installation

Remove the spark plug hole packing from the cylinder head cover.

Install the spark plug hole packing to the spark plug hole.

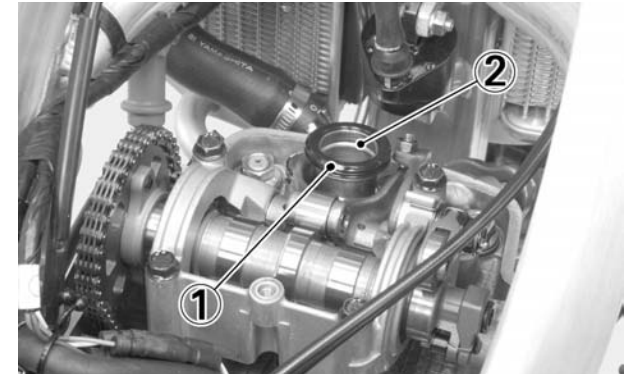

- (1) SPARK PLUG HOLE PACKING
(2) SPARK PLUG HOLE

Install the cylinder head packing into the groove of the cylinder head cover.

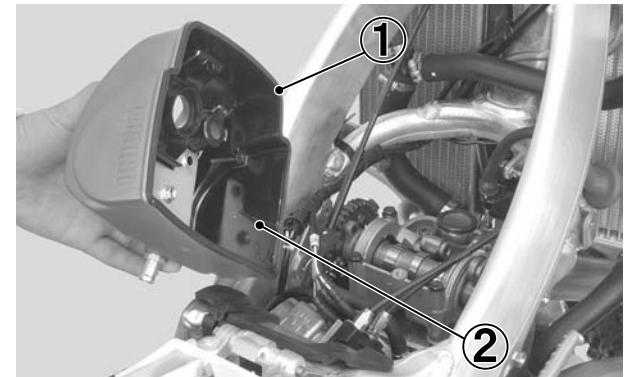

- (1) PACKING
(2) CYLINDER HEAD COVER

Install the cylinder head cover, cylinder head cover B bolts and cylinder head cover A bolt.

TORQUE: 7 lbf·ft (10 N·m, 1.0 kgf·m)



- (1) CYLINDER HEAD COVER
- (2) CYLINDER HEAD COVER B BOLTS
- (3) CYLINDER HEAD COVER A BOLT

Connect the spark plug cap and breather tube.

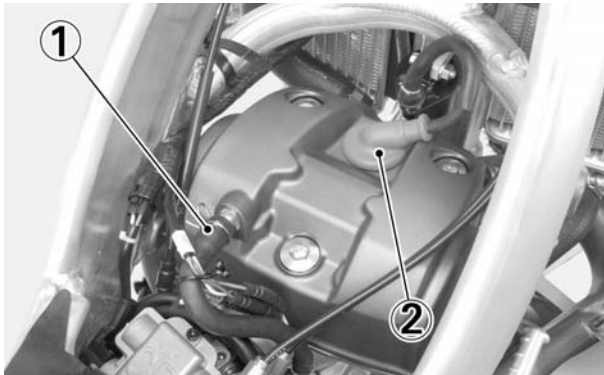

- (1) BREATHER TUBE
- (2) SPARK PLUG CAP

Install the fuel tank (page 18).
Install the seat (page 17).

PISTON/PISTON RINGS/PISTON PIN

Cylinder Head Removal

NOTE:

- Clean the area above the engine before disassembly to prevent dirt falling into the engine.

Drain the engine oil (page 21).
Drain the radiator coolant after cooling the motorcycle (page 101).
Remove the seat (page 17).
Remove the fuel tank (page 17).
Remove the muffler and subframe (page 19).
Remove the carburetor (page 62).
Remove the exhaust pipe joint nuts, exhaust pipe and exhaust pipe gasket.

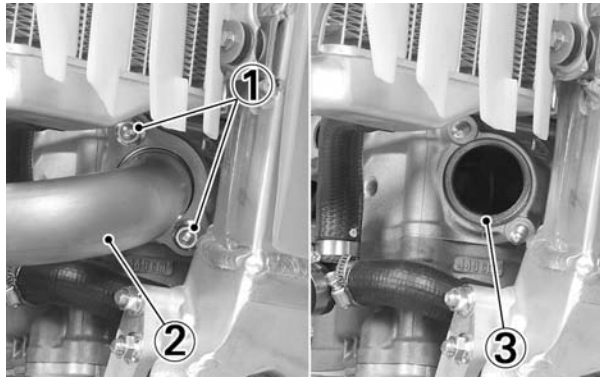

- (1) EXHAUST PIPE JOINT NUTS
- (2) EXHAUST PIPE
- (3) EXHAUST PIPE GASKET

Disconnect the spark plug cap and remove the ignition coil nut, ignition coil bolts and ignition coil.

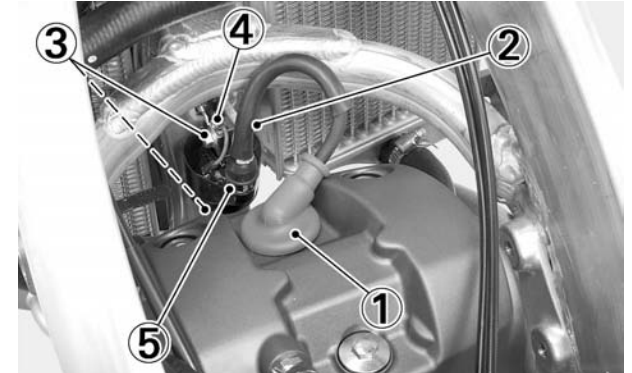

- (1) SPARK PLUG CAP
- (2) IGNITION COIL NUT
- (3) IGNITION COIL BOLTS
- (4) GROUND TERMINAL
- (5) IGNITION COIL

Remove the cylinder head cover (page 30).
Remove the spark plug.

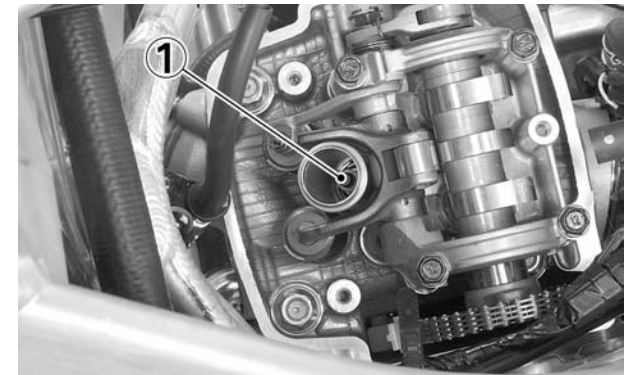

- (1) SPARK PLUG

4. SERVICE AND MAINTENANCE

Position the piston at top dead center on the compression stroke (page 30).
Remove the cam shaft holder assembly (page 32).
Loosen the radiator hose clamp and disconnect the radiator hose.

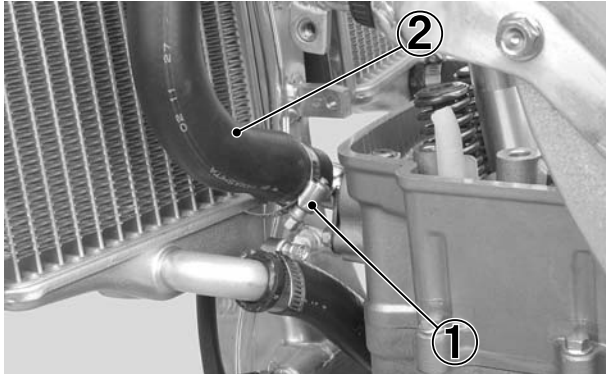

- (1) RADIATOR HOSE CLAMP
- (2) RADIATOR HOSE

Remove the engine hanger nut, engine hanger A bolt, right collar, left collar and fuel hose guide.
Remove the engine hanger B bolts, left engine hanger plate and right engine hanger plate.

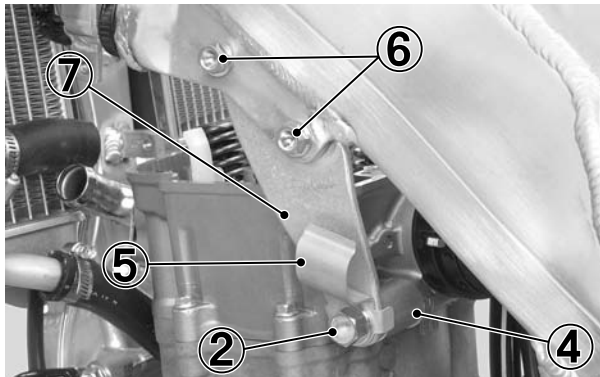
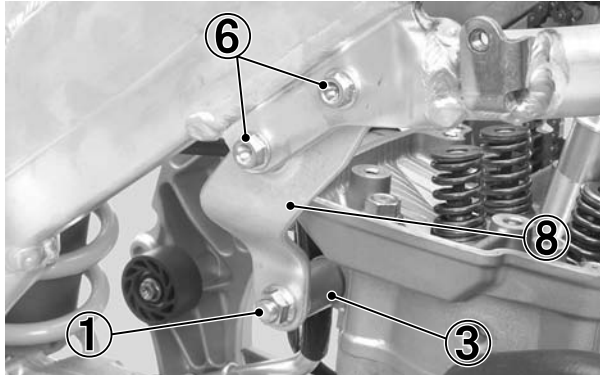

- (1) ENGINE HANGER NUT
- (2) ENGINE HANGER A BOLT
- (3) RIGHT COLLAR
- (4) LEFT COLLAR
- (5) FUEL HOSE GUIDE
- (6) ENGINE HANGER B BOLTS
- (7) LEFT ENGINE HANGER PLATE
- (8) RIGHT ENGINE HANGER PLATE

Remove the cylinder head bolts.
Loosen the cylinder bolt.

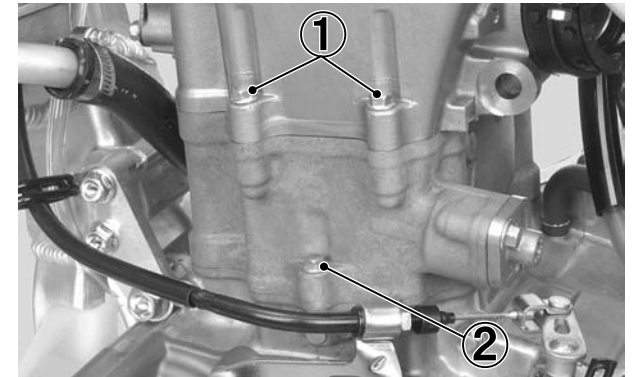

- (1) CYLINDER HEAD BOLTS
- (2) CYLINDER BOLT

Remove the cylinder head nuts, washers and the cylinder head.

CAUTION:

- *Do not let the nuts, washers and cam chain fall into the crankcase.*

NOTE:

- Loosen the nuts in a criss-cross pattern in 2 or 3 steps.

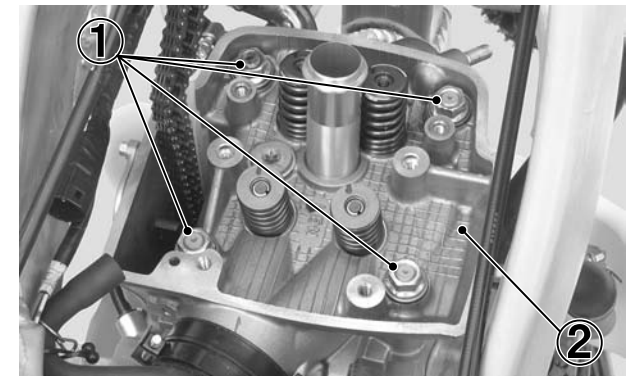

- (1) CYLINDER HEAD NUTS/WASHERS
- (2) CYLINDER HEAD

Remove the dowel pins, cylinder head gasket and cam chain guide.

CAUTION:

- *Do not let the dowel pins and cam chain fall into the crankcase.*

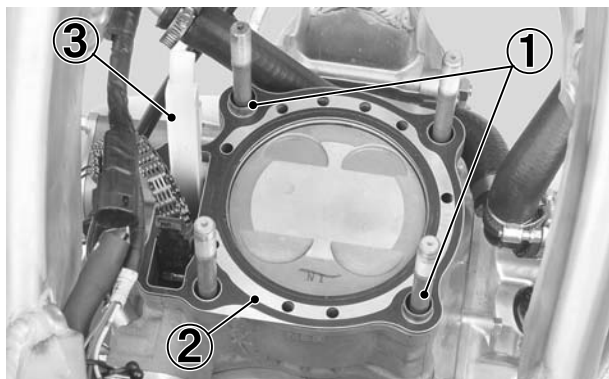

- (1) DOWEL PINS
- (2) CYLINDER HEAD GASKET
- (3) CAM CHAIN GUIDE

Cylinder Removal

Remove the cylinder bolt and cylinder.

CAUTION:

- *Do not let the cam chain fall into the crankcase.*
- *Do not pry on or strike the cylinder.*

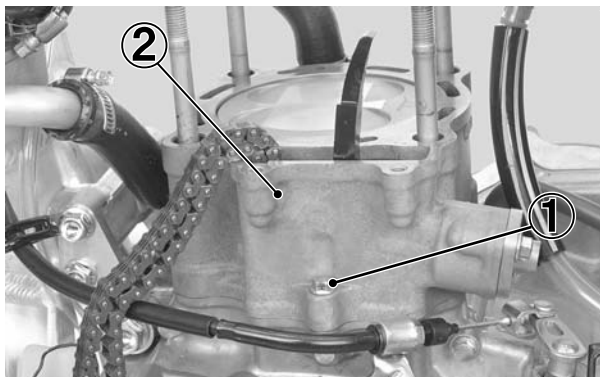

- (1) CYLINDER BOLT
- (2) CYLINDER

Remove the A dowel pins, B dowel pin and cylinder gasket.

CAUTION:

- *Do not let the dowel pins fall into the crankcase.*

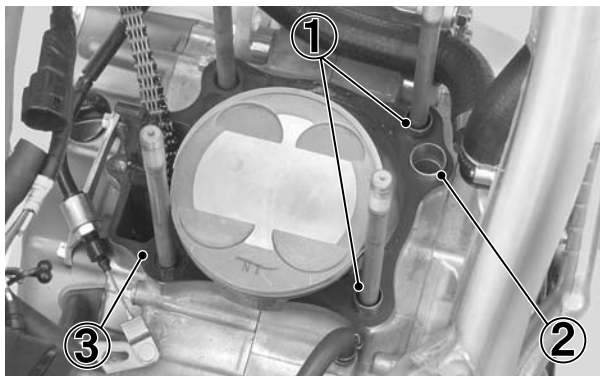

- (1) A DOWEL PINS
- (2) B DOWEL PIN
- (3) CYLINDER GASKET

Piston Removal

Place clean shop towels in the crankcase to keep the piston pin clips, or other parts, from falling into the crankcase.

Remove the piston pin clips using a pair of needle-nose pliers.

Press the piston pin out of the piston, and remove the piston.

CAUTION:

- *Do not damage the piston*
- *Always support the piston when pressing out the pin.*
- *Do not let the clips fall into the crankcase.*

NOTE:

- Under racing conditions, the piston and rings should be replaced after 15.0 hours of running. Replace the piston pin after 30.0 hours of running.

Spread each piston ring and remove by lifting it up at a point just opposite the gap.

CAUTION:

- *Do not damage the piston ring by spreading the ends too far.*

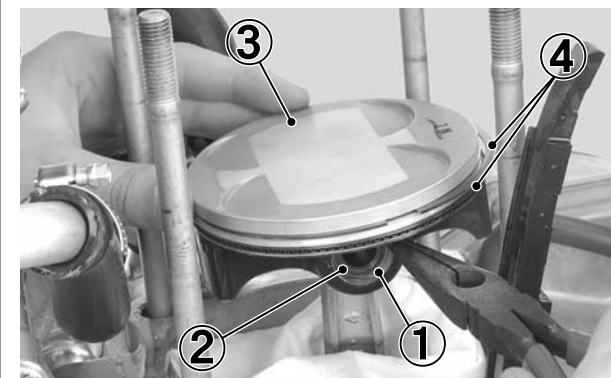

- (1) PISTON PIN CLIP
- (2) PISTON PIN
- (3) PISTON
- (4) PISTON RINGS

4. SERVICE AND MAINTENANCE

Cam Shaft Holder Assembly/Cylinder Head/Cylinder/ Piston/Piston Pin/Piston Ring Inspection

We recommended you consult the Service Manual or your authorized Honda dealer for correct Service Limit measurements.

Piston Ring Installation.

Clean the piston ring groove

Apply engine oil to the piston rings and install the piston rings.

CAUTION:

- **Do not damage the piston ring by spreading the ends too far.**
- **Do not damage the piston during piston ring installation.**

NOTE:

- To install the oil ring, install the spacer first, then install the side rails.
- Install the top ring on the piston with the marking side facing up.

After installing the rings they should rotate freely, without sticking.

Space the ring end gaps 180 degrees apart between top ring and upper side rail.

Space the ring end gaps 120 degrees apart between upper side rail, spacer and lower side rail.

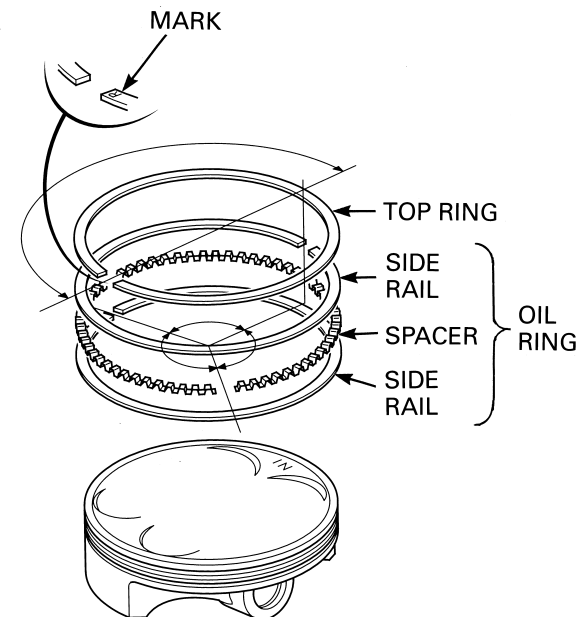
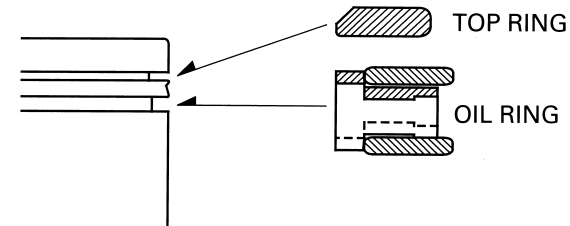

Piston Installation

Place clean shop towels in the crankcase to keep the piston pin clips from falling into the crankcase. Apply molybdenum disulfide oil (a mixture of 1/2 engine oil and 1/2 molybdenum disulfide grease (containing more than 3% molybdenum disulfide additive)) to the connecting rod small end. Install the piston with the "IN" mark and/or the large valve recesses facing the intake side of the engine. Apply fresh engine oil to the piston pin. Install the piston pin and new piston pin clips.

CAUTION:

- *Use new pin clips. Never reuse old clips.*
- *Do not let the clips fall into the crankcase.*
- *Do not align the piston pin clip end gap with the piston cut-out.*

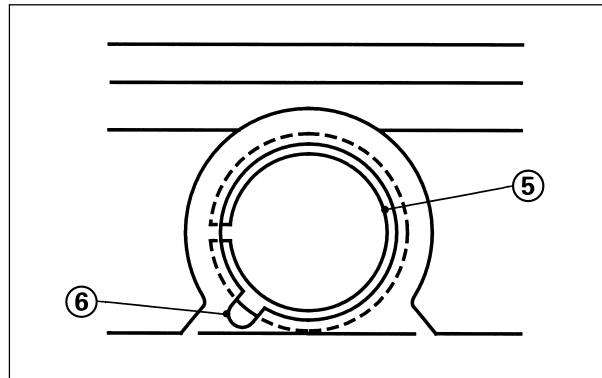
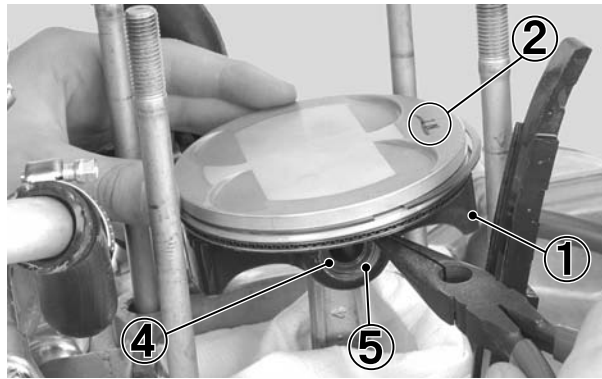
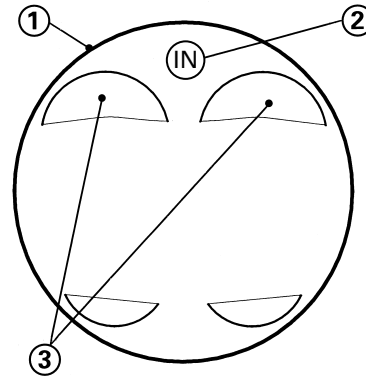

- (1) PISTON (2) "IN" MARK
(3) LARGE VALVE RECESSES (5) PISTON PIN CLIP
(4) PISTON PIN (6) CUT-OUT

Cylinder Installation

Clean off any gasket material from the gasket surface of the crankcase, being careful not to let any material fall into the crankcase.

NOTE:

- Be careful not to remove any metal from the gasket surface.

Remove the shop towel. Do not let any gasket debris fall into the crankcase. Install cylinder gasket, A dowel Pins and B dowel pin.

CAUTION:

- *Do not let the dowel pins fall into the crankcase.*

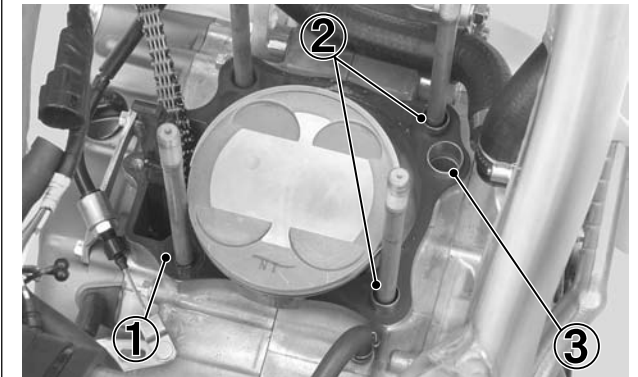

- (1) CYLINDER GASKET
(2) A DOWEL PINS
(3) B DOWEL PIN

Clean the any gasket material off the cylinder.

4. SERVICE AND MAINTENANCE

Apply fresh engine oil to the cylinder wall, piston outer surface and piston rings.

Route the cam chain through the cylinder.

Install the cylinder over the piston rings by hand while compressing the piston rings.

CAUTION:

- **Do not damage the piston rings and cylinder walls.**

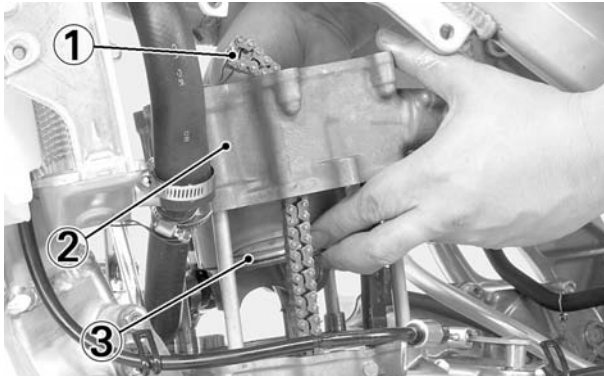

- (1) CAM CHAIN
(2) CYLINDER
(3) PISTON RINGS

Install the cam chain guide and fit the cam chain guide tabs in the cylinder cut-outs. Push the guide until bottoms in the crankcase guide hole.

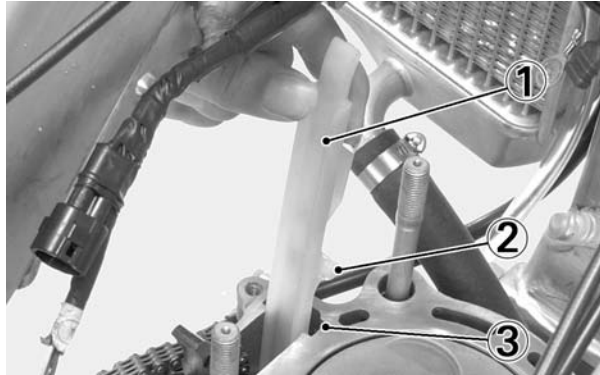

- (1) CAM CHAIN GUIDE
(2) CAM CHAIN GUIDE TABS
(3) CYLINDER CUT-OUTS

Cylinder Head Installation

Install the dowel pins and new cylinder head gasket.

CAUTION:

- **Do not let the dowel pins fall into the crankcase.**

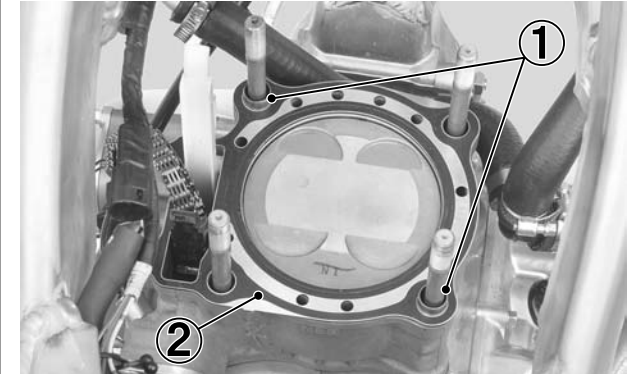

- (1) DOWEL PINS
(2) CYLINDER HEAD GASKET

Route the cam chain through the cylinder head.
Install the cylinder head.

CAUTION:

- **Do not damage mating surfaces when installing the cylinder head.**

Apply engine oil to all cylinder head nut threads.
Install the washers and cylinder head nuts and tighten to the specified torque.

TORQUE: 43 lbf·ft (59 N·m, 6.0 kgf·m)

CAUTION:

- **Do not let the washers and nuts fall into the crankcase.**

NOTE:

- Tighten the cylinder head nuts in a criss-cross pattern in 2 or 3 steps.

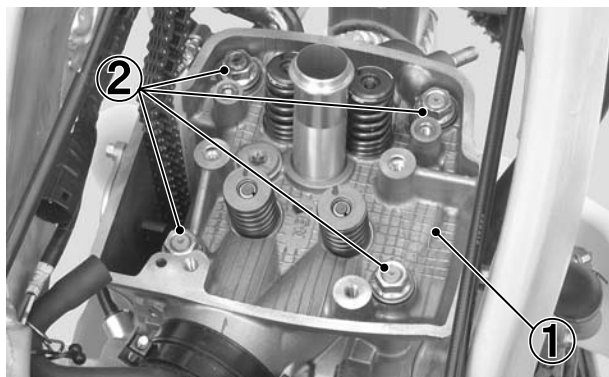

(1) CYLINDER HEAD
(2) CYLINDER HEAD NUTS/WASHERS

Install the cylinder bolt and cylinder head bolts to the specified torque.

TORQUE: 7 lbf·ft (10 N·m, 1.0 kgf·m)

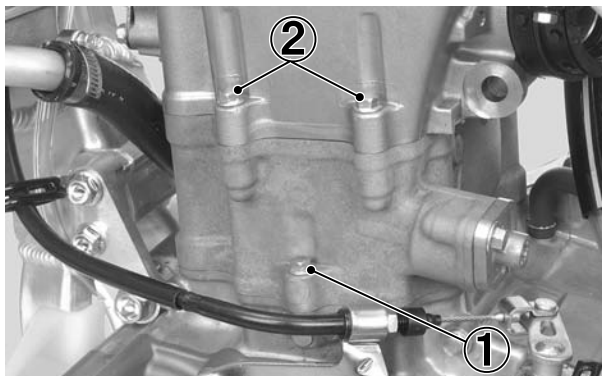

(1) CYLINDER BOLT
(2) CYLINDER HEAD BOLTS

Install the left engine hanger plate, right engine hanger plate and engine hanger B bolts and tighten the engine hanger B bolts until lightly contact the frame.
Install the engine hanger A bolt, fuel hose guide, left collar, right collar and engine hanger nut and tighten the engine hanger nut until it lightly contacts the engine hanger plates.

Tighten the engine hanger B bolts.

TORQUE: 20 lbf·ft (26 N·m, 2.7 kgf·m)

Tighten the engine hanger nut.

TORQUE: 40 lbf·ft (54 N·m, 5.5 kgf·m)

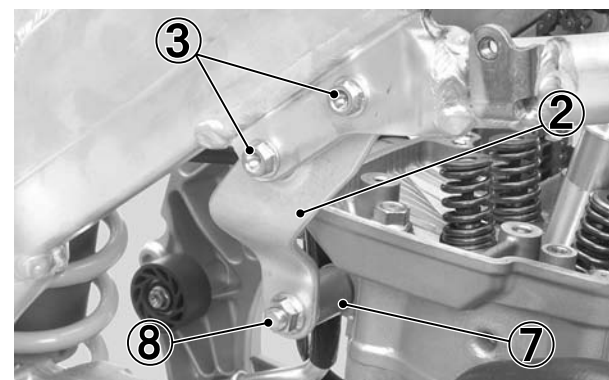
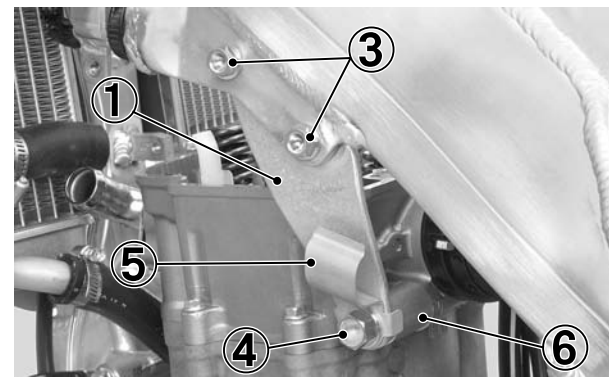

(1) LEFT ENGINE HANGER PLATE
(2) RIGHT ENGINE HANGER PLATE
(3) ENGINE HANGER B BOLTS
(4) ENGINE HANGER A BOLT
(5) FUEL HOSE GUIDE
(6) LEFT COLLAR
(7) RIGHT COLLAR
(8) ENGINE HANGER NUT

4. SERVICE AND MAINTENANCE

Connect the radiator hose to the cylinder head and tighten the radiator hose clamp securely.

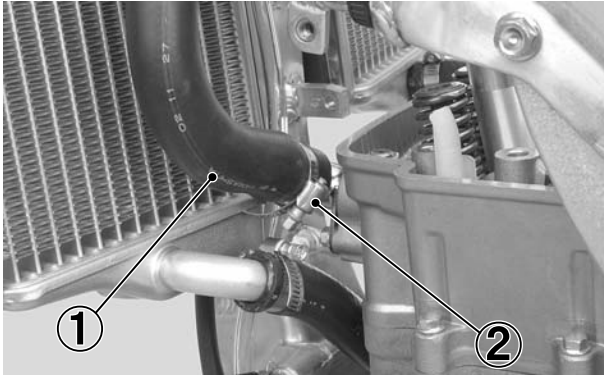

- (1) RADIATOR HOSE
- (2) RADIATOR HOSE CLAMP

Install the shims and cam shaft holder assembly (page 34).

Install the spark plug with a spark plug wrench until finger tight, then tighten with a spark plug wrench until the sealing gasket is compressed (1/2 turn to compress a new spark plug gasket, 1/8 – 1/4 turn to compress a spark plug with a used gasket).

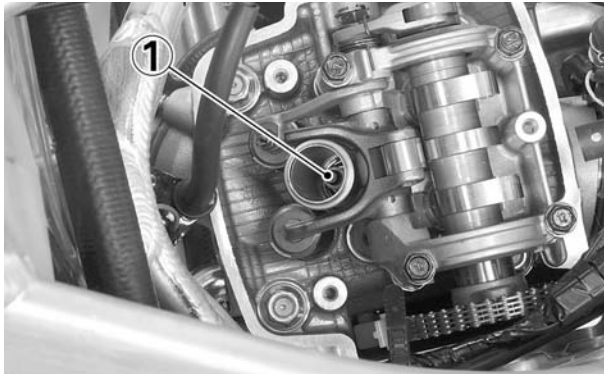

- (1) SPARK PLUG

Install the crankshaft hole cap (page 38).
Install the cylinder head cover (page 38).
Install the ignition coil, ground terminal, ignition coil bolts and ignition coil nut.
Connect the primary wire and spark plug cap.

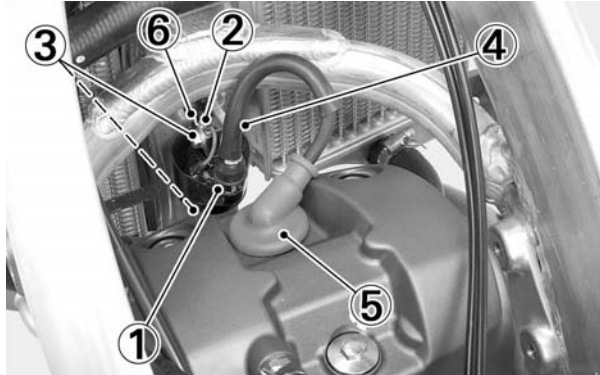

- (1) IGNITION COIL
- (2) GROUND TERMINAL
- (3) IGNITION COIL BOLTS
- (4) IGNITION COIL NUT
- (5) SPARK PLUG CAP
- (6) PRIMARY WIRE

Install a new exhaust pipe gasket, exhaust pipe and exhaust pipe joint nuts and tighten to the specified torque.

TORQUE: 15 lbf·ft (21 N·m, 2.1 kgf·m)

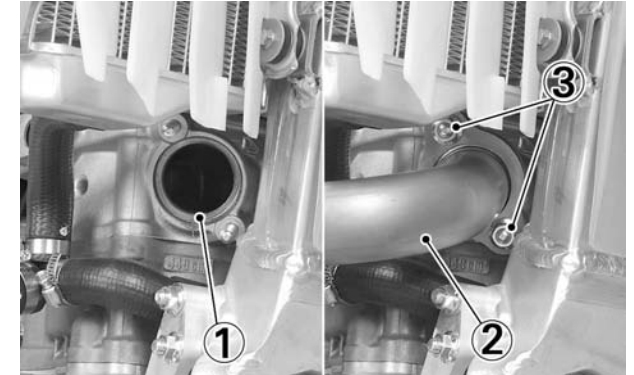

- (1) EXHAUST PIPE GASKET
- (2) EXHAUST PIPE
- (3) EXHAUST PIPE JOINT NUTS

Install the carburetor (page 62) .
Install the subframe and muffler (page 19).
Install the fuel tank (page 18).
Install the seat (page 17).

Pour a fresh recommended coolant mixture (page 24) slowly into the radiator filler hole up to the filler neck.

Capacity: 1.18 US qt (1.12 liter, 0.99 Imp qt)

Lean your CRF slightly right and left several times to bleed trapped air in the cooling system.

If the coolant level lowers, add coolant and repeat the above procedure.

Install the radiator cap securely.



(1) RADIATOR CAP

Check for the following:

- compression leaks
- abnormal engine noise
- secondary air leaks
- coolant leaks

HANDLEBAR AND STEERING HEAD BEARINGS

1. Remove the handlebar pad and check the handlebar for bends or cracks.
2. Check that the handlebar has not moved from its proper position (by inspecting the paint mark alignment). Check that the upper holders are torqued to **16 lbf·ft (22 N·m, 2.2 kgf·m)**. Tighten the front bolts first.
3. With your CRF on a box or workstand (front wheel elevated), turn the handlebar to the right and left to check for roughness in the steering head bearings. Now, stand in front of your CRF and grab the fork (at the axle), then push the fork in and out (toward the engine) to check for play in the steering head bearings. If any roughness or play is felt, refer to the Honda Service Manual for replacement or adjustment procedures.

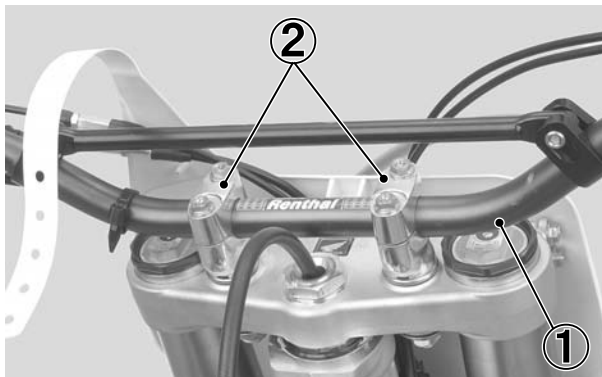

(1) HANDLEBAR
(2) HANDLEBAR UPPER HOLDERS

THROTTLE GRIP

Inspection

Check for smooth rotation of the throttle grip from the fully closed to the fully open position. Check at full left and full right steering positions. Inspect the condition of the throttle cables from the throttle grip down to the carburetor. If the cables are kinked, chafed or improperly routed, they should be replaced or rerouted. Check the cables for tension or stress at both full left and full right steering positions.

▲WARNING

- **For safe operation and positive engine response, the throttle cables must be properly adjusted.**

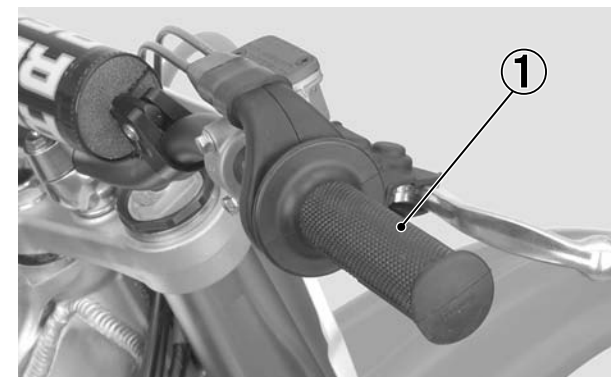

(1) THROTTLE GRIP

4. SERVICE AND MAINTENANCE

FUEL LINE

1. Check the fuel valve and fuel filter for contamination.
2. Check for leaks.
3. Check the fuel line for cracks, deterioration or leakage.
4. Check for interference between the frame and tank and adjust if necessary.

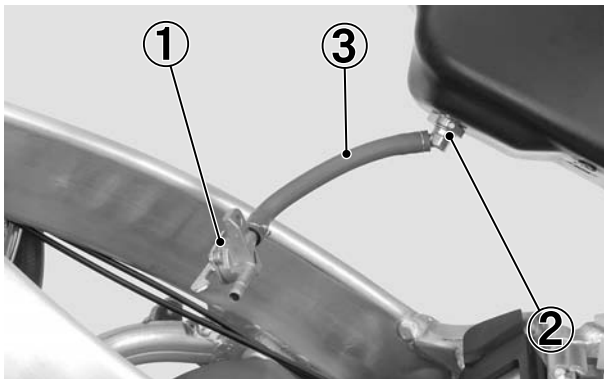
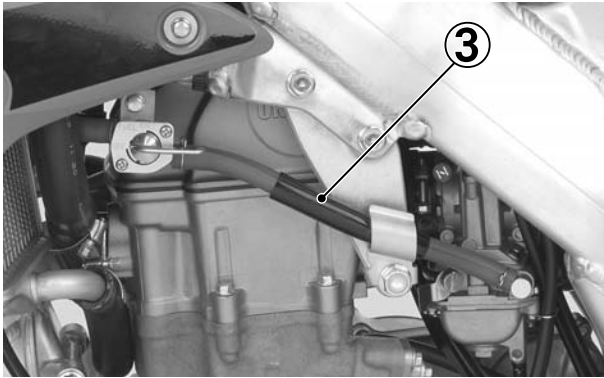

- (1) FUEL VALVE
(2) FUEL FILTER
(3) FUEL LINE

Fuel Filter

The fuel filter is mounted on the bottom of the fuel tank. Accumulation of dirt in the filter will restrict the flow of the fuel to the carburetor. Therefore, the fuel filter should be serviced frequently.

To Service

1. Drain the fuel from the fuel tank into an approved gasoline container.
2. Remove the fuel tank (page 17).
3. Disconnect the fuel line.
4. Remove the fuel filter by removing the bolts. Wash the fuel filter in high flash-point cleaning solvent.

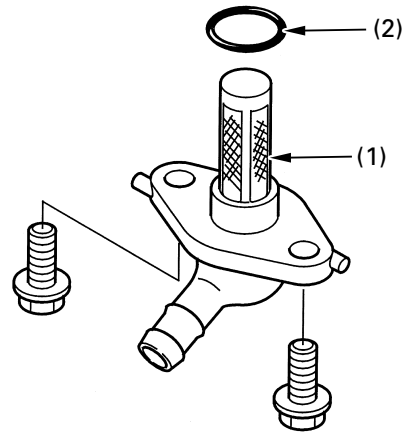

(1) FUEL FILTER

(2) O-RING

5. Reassemble the fuel filter in the reverse order of removal. Make sure the O-ring is in place. Install the fuel filter in the fuel tank. Connect the fuel line. Install the fuel tank (page 18). Refill the fuel tank. Turn the fuel valve ON and check for leaks.

▲ WARNING

- **Gasoline is extremely flammable and is explosive under certain conditions. Perform this operation in a well-ventilated area with the engine stopped. Do not smoke or allow flames or sparks in the area where gasoline is drained or stored and where the fuel tank is refueled.**

FRONT AND REAR WHEELS AND TIRES

Tires

Proper air pressure will provide maximum stability, riding comfort and tire life. Check tire pressure frequently and adjust if necessary.

NOTE :

- Tire pressure should be checked when the tires are "cold".

| | |
|--|---|
| Cold tire pressures psi (kPa, kgf/cm ²) | Front: 15 (100, 1.0) Rear: 15 (100, 1.0) |
| Tire size | Front: 80/100-21 M/C 51M Rear: 110/90-19 M/C 62M |

Wheel Rims And Spokes

1. Inspect wheel rims and spokes for damage.
2. Tighten any loose spokes and rim locks.

TORQUE:

Spoke: 2.7 lbf·ft (3.7 N·m, 0.38 kgf·m)

Rim lock: 9.4 lbf·ft (13 N·m, 1.3 kgf·m)

3. Check wheel rim runout. If runout is noticeable, see the Honda Service Manual for inspection.

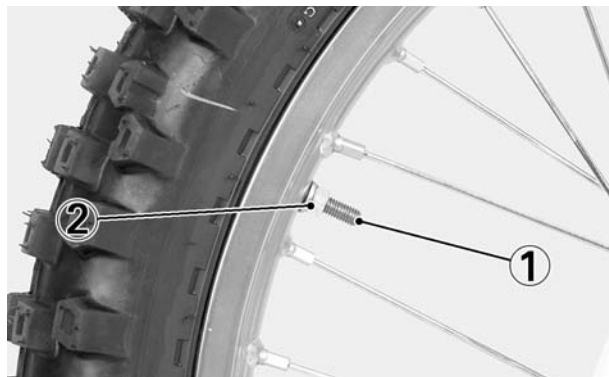

(1) RIM LOCK

(2) LOCK NUT

Axles And Wheel Bearings (See the Honda Service Manual for inspection):

1. Check the axle for runout.
2. Check the condition of the wheel bearings.

FRONT SUSPENSION

Inspection

1. Make sure that the fork protectors and dust seals are clean and not packed with mud and dirt.
2. Check for signs of oil leakage. Damaged or leaking fork seals should be replaced before your CRF is ridden.

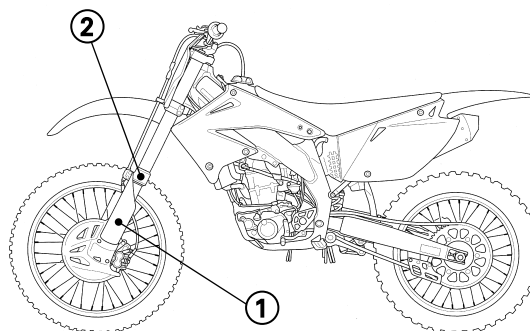

(1) FORK PROTECTOR

(2) DUST SEAL

3. Inspect the wear rings for wear or damage. Replace the wear ring if it is 0.06 in (1.5 mm) or flat with the outer tube.

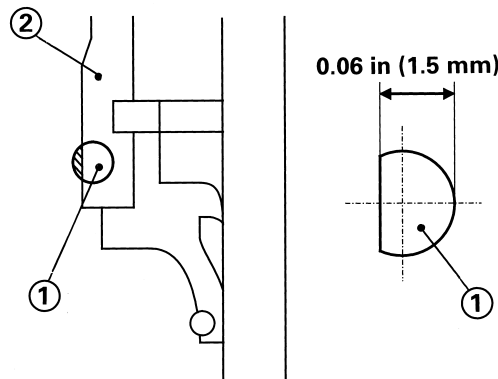

(1) WEAR RING

(2) OUTER TUBE

NOTE :

- Install the wear ring with its end gap facing rearward.

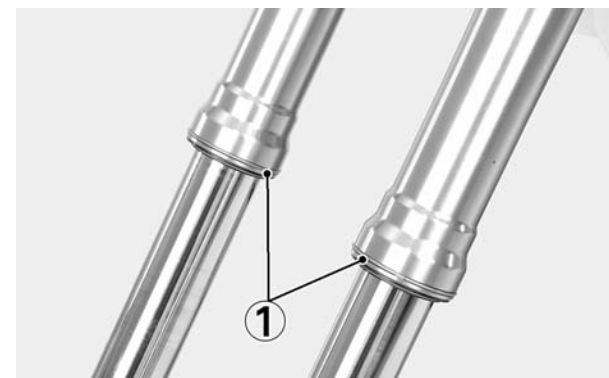

(1) WEAR RINGS

4. SERVICE AND MAINTENANCE

4. Make a quick check of fork operation by locking the front brake and pushing down on the handlebar several times.

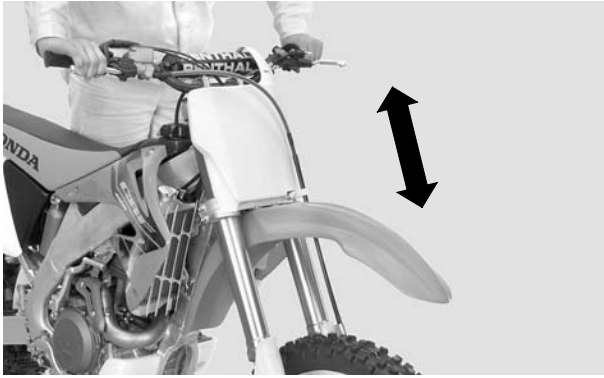

▲ WARNING

- ***If any suspension components appear worn or damaged, consult your authorized Honda dealer for further inspection. The suspension components are directly safety-related and your authorized Honda dealer is qualified to determine whether or not replacement parts or repairs are needed.***
- ***Contact your Honda dealer for repair of any steering or front suspension wear or damage.***
- ***Do not operate the motorcycle with loose, worn or damaged steering or front suspension components, as handling will be adversely affected.***

NOTE :

- When your CRF is new, break it in for approximately one hour to ensure that the suspension has worked in (page 3).
- After break-in, test run your CRF with the front suspension at the standard setting before attempting any adjustments.
- For optimum fork performance, we recommend that you disassemble and clean the fork after riding your CRF for three hours. See page 83 for fork disassembly.
- Replace the tube/slider fork oil every 3 races or 7.5 hours of running. See Section 6 for tube/slider fork oil replacement/adjustment.
- Replace the damper fork oil every 9 races or 22.5 hours of running. See Section 6 for damper fork oil replacement.
- Use Pro Honda HP Fork Oil 5W or an equivalent which contains special additives to assure maximum performance of your CRF front suspension.
- Periodically check and clean all front suspension parts to assure top performance. Check the dust seals for dust, dirt, and foreign materials. Check the oil for any contamination.
- Refer to Section 6 for Suspension Adjustment information. Make all rebound and compression damping adjustments in one-click increments. (Adjusting two or more clicks at a time may cause you to pass over the best adjustment.) Test ride after each adjustment.
- If you become confused about adjustment settings, return to the standard position and start over.
- If the fork is still too stiff/soft after adjusting compression damping, determine which portion of the travel is still too stiff/soft. This is an important step that will help you solve suspension problems.

See page 91 for front suspension adjustment.

REAR SUSPENSION

The swingarm is controlled by one hydraulic shock absorber with an aluminum reservoir for oil and nitrogen gas pressure. The gas pressure in the reservoir is contained within a rubber bladder.

The shock absorber's spring preload and damping adjustments (compression and rebound) should be adjusted for the rider's weight and track conditions. (See Section 6.)

▲ WARNING

- ***The rear shock absorber assembly includes a damper unit that contains high pressure nitrogen gas. The instructions found in this owner's manual are limited to adjustment of the shock assembly only. Do not attempt to disassemble, disconnect or service the damper unit; an explosion, causing serious injury may result.***
- ***Puncture or exposure to flame may also result in an explosion, causing serious injury.***
- ***Service or disposal should only be done by your authorized Honda dealer or a qualified mechanic, equipped with the proper tools, safety equipment and the official Honda Service Manual.***

NOTE:

- When your CRF is new, break it in for approximately one hour with the standard suspension settings before attempting to adjust the rear suspension.
- Make all compression and rebound damping adjustments in specified increments or turns described in page 73. (Adjusting two or more increments or turns at a time may cause you to pass over the best adjustment.) Test ride after each adjustment.
- If the rear suspension is too stiff/soft, adjust it by turning all the compression and rebound adjusters according to the procedures described in page 73. After adjusting the adjusters simultaneously, suspension may be fine-tuned by turning one of the compression or rebound damping adjusters in one-click or in 1/12 turn increments.
- If you have a problem finding an acceptable adjustment, return to the standard position and begin again.

Inspection

1. Bounce the rear of the motorcycle up and down and check for smooth suspension action.



2. Remove the subframe (page 19)
3. Check for a broken or collapsed spring.
4. Check the shock for a bent shaft or oil leaks.

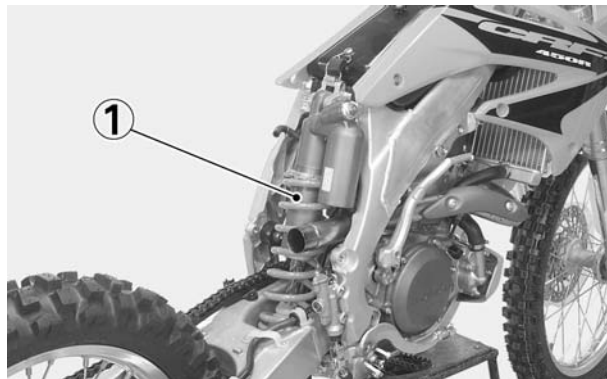

(1) REAR SHOCK ABSORBER

5. Push the rear wheel sideways to check for worn or loose swingarm bearings. There should be no movement. If there is, have the bearings replaced by your authorized Honda motorcycle dealer.

BRAKES

Your CRF has hydraulic disc front and rear brakes. As the brake pads wear, the brake fluid level will drop. Therefore, the brake fluid level and pad wear must be inspected periodically.

Front Brake Fluid

Whenever the fluid level is near the lower mark on the reservoir, fill it with DOT 4 BRAKE FLUID from a sealed container. Remove the screws, reservoir cap and diaphragm, add fluid as necessary; do not overfill. Reinstall the diaphragm and reservoir cap. Tighten the screws.

TORQUE: 1.1 lbf·ft (1.5 N·m, 0.15 kgf·m)

If the brake lever free play exceeds 0.8 in (20 mm), there is probably air in the brake system and it must be bled. Refer to the Honda Service Manual or see your authorized Honda motorcycle dealer for brake bleeding.

CAUTION:

- *When adding brake fluid be sure the reservoir is horizontal before the cap is removed or brake fluid may spill out.*

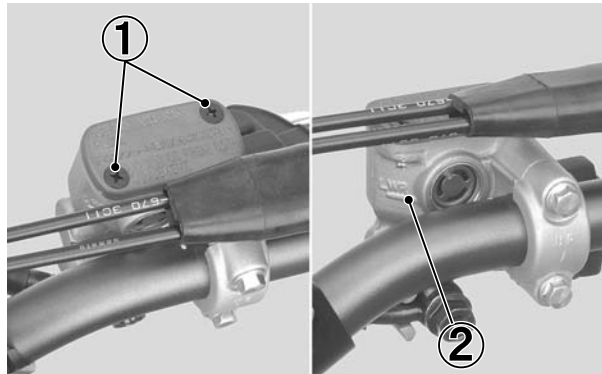

(1) SCREWS

(2) LOWER LEVEL MARK

Rear Brake Fluid

Whenever the fluid level is near the lower mark on the reservoir, fill it with DOT 4 BRAKE FLUID from a sealed container. Remove the bolts, reservoir cap and diaphragm. Add the brake fluid to the upper level mark if necessary; do not overfill. Reinstall the diaphragm, reservoir cap and tighten the bolts.

TORQUE: 1.1 lbf·ft (1.5 N·m, 0.15 kgf·m)

If the brake pedal free play exceeds 0.8 in (20 mm), there is probably air in the brake system and it must be bled. Refer to the Honda Service Manual or see your authorized Honda motorcycle dealer for brake bleeding.

CAUTION:

- *When adding brake fluid be sure the reservoir is horizontal before the cap is removed or brake fluid may spill out.*

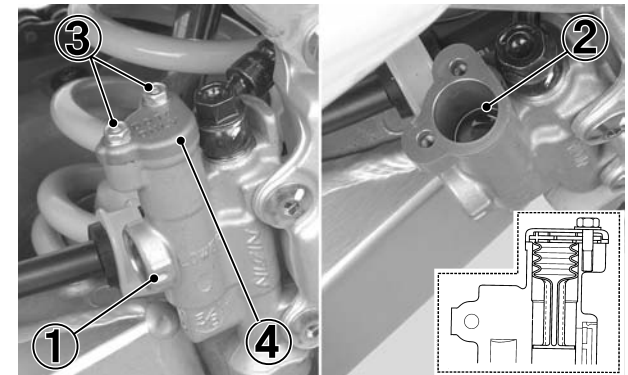

(1) LOWER LEVEL MARK
(3) BOLTS

(2) UPPER LEVEL MARK
(4) RESERVOIR CAP

Adjustment for free play of the lever and the pedal height, see page 6.

4. SERVICE AND MAINTENANCE

Front Brake Pads

Inspect the pads visually through the front wheel to determine the pad wear. If either pad is worn anywhere to a thickness of 0.04 in (1 mm), both pads must be replaced.

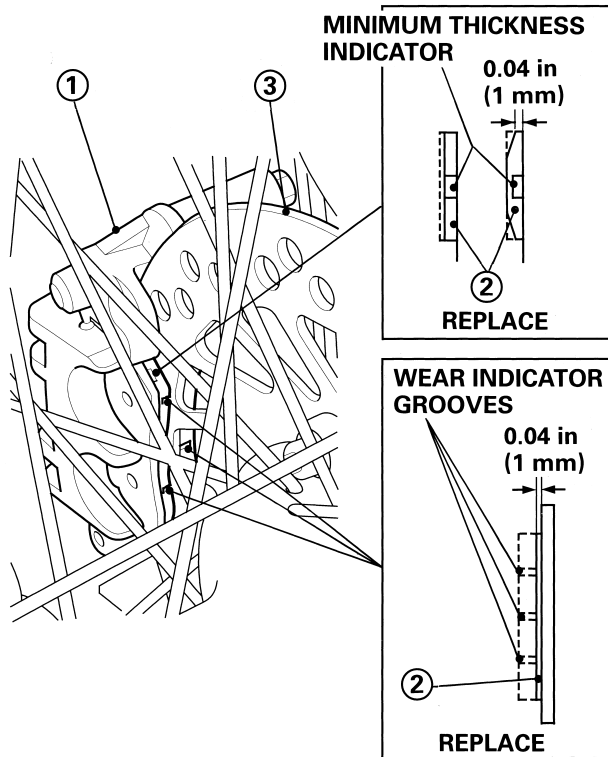

- (1) FRONT BRAKE CALIPER
(2) BRAKE PADS
(3) BRAKE DISC

Rear Brake Pads

Inspect the pads visually from the rear side of the caliper to determine the pad wear. If either pad is worn anywhere to a thickness of 0.04 in (1 mm), both pads must be replaced.

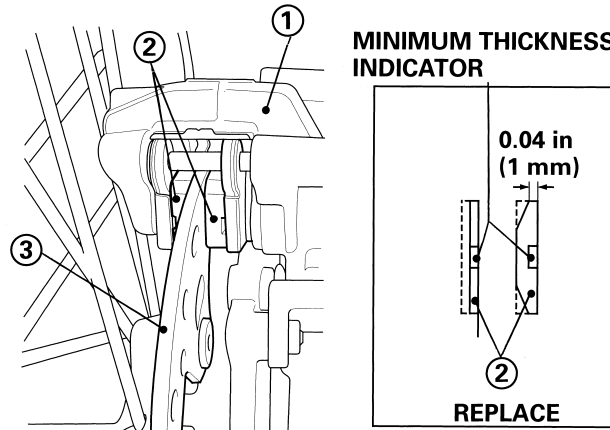

- (1) REAR BRAKE CALIPER
(2) BRAKE PADS
(3) BRAKE DISC

Other Checks

Make sure there are no fluid leaks. Check for deterioration or cracks in the hoses and fittings.

DRIVE CHAIN

Regular cleaning, lubrication, and proper adjustment will help to extend the service life of the drive chain.

▲ WARNING

- *Take care to prevent catching your fingers between the chain and sprocket.*

Inspection

1. Turn the engine off, raise the rear wheel off the ground by placing the optional workstand or equivalent support under the engine and shift the transmission into neutral.
2. Check slack in the drive chain midway between the sprockets, above the swingarm. Drive chain slack should allow 1 – 1-3/8 in (25–35 mm) of vertical movement.

NOTE:

- Excessive chain slack may allow the drive chain to damage the engine cases.

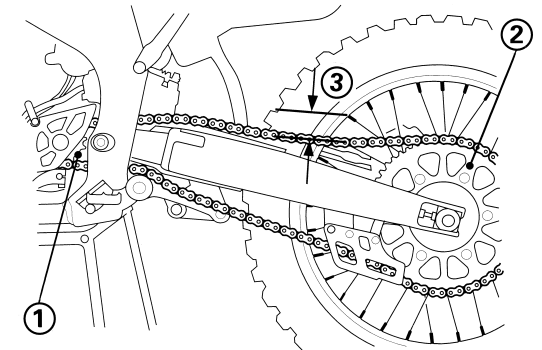

- (1) DRIVE SPROCKET
(2) DRIVEN SPROCKET
(3) DRIVE CHAIN SLACK

If the chain is found to be slack in one segment of its length and taut in another, this indicates that some of the links are either worn, kinked or binding. Kinking and binding can frequently be eliminated by thorough cleaning and lubrication. If the drive chain requires adjustment, the procedure is as follows:

Adjustment

1. Loosen the rear axle nut.
2. Loosen the lock nuts and turn the adjusting bolt counterclockwise to decrease slack or clockwise to increase slack.
Align the index mark of the axle plates with the same reference marks on both sides of the swingarm.

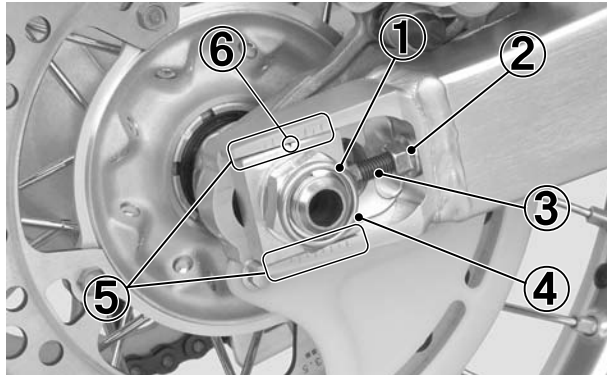

- (1) REAR AXLE NUT (2) LOCK NUT
(3) ADJUSTING BOLT (4) AXLE PLATE
(5) REFERENCE MARKS (6) INDEX MARK

3. Tighten and torque the rear axle nut.

TORQUE: 94 lbf·ft (127 N·m, 13.0 kgf·m)

4. Recheck chain slack and adjust if necessary.
5. Loosen the adjusting bolt counterclockwise lightly until it touches the axle plate. Then, tighten and torque the lock nut by holding the adjusting bolt with a wrench.

TORQUE: 20 lbf·ft (26 N·m, 2.7 kgf·m)

Removal, Cleaning and Inspection

For maximum service life, the drive chain should be cleaned, lubricated, and adjusted before each outing.

1. Carefully remove the master link retaining clip with pliers. Remove the master link and drive chain.
2. Clean the drive chain in high flash-point solvent and allow it to dry. Inspect the drive chain for possible wear or damage. Replace any chain that has damaged rollers, loose or tight fitting links, or otherwise appears unserviceable.

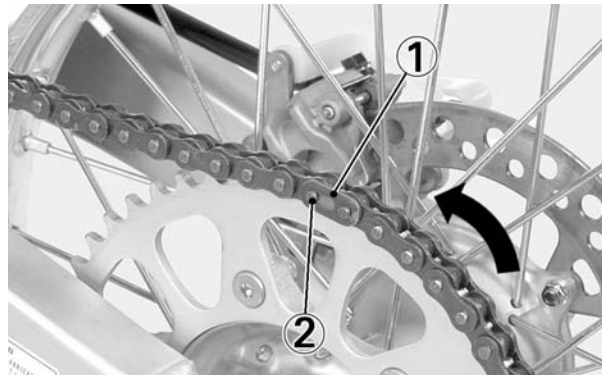

- (1) RETAINING CLIP (2) MASTER LINK

3. Inspect the sprocket teeth for possible wear or damage. Replace if necessary.

NOTE:

- Never install a new drive chain on badly worn sprockets, or use new sprockets with a badly worn drive chain. Both chain and sprockets must be in good condition, or the new replacement chain or sprocket(s) will wear rapidly.
- Excessively worn sprocket teeth have a hooked, worn appearance. Replace any sprocket which is damaged or excessively worn.

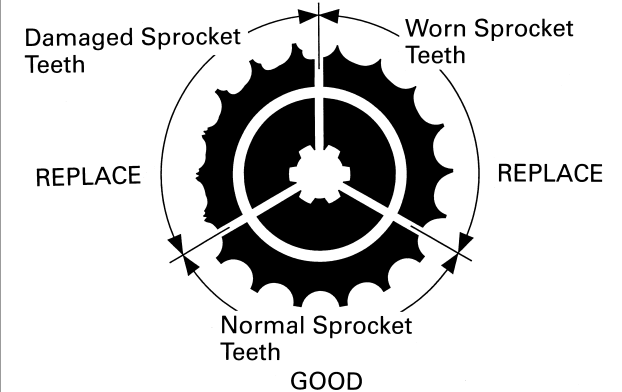

4. Measure a section of the drive chain to determine whether the chain is worn beyond its service limit. Put the transmission in gear, and then turn the rear wheel forward until the lower section of the chain is pulled taut. With the chain held taut and any kinked joints straightened, measure the distance between a span of 17 pins, from pin center to pin center. If the measurement exceeds the service limit, replace the chain. After the chain is measured, shift the transmission into neutral again before proceeding with inspection and service.

Replacement chain: D.I.D 520DMA2

SERVICE LIMIT: 10.20 in (259.0 mm)

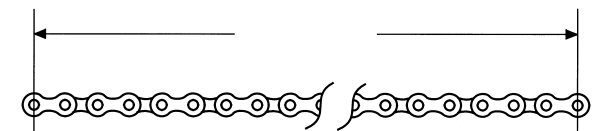

MEASURE A SPAN OF 17 PINS (16 PITCHES)

4. SERVICE AND MAINTENANCE

5. Lubricate the drive chain.
6. Pass the chain over the sprockets and join the ends of the chain with the master link. For ease of assembly, hold the chain ends against adjacent rear sprocket teeth while inserting the master link. Install the master link retaining clip so that the closed end of the clip will face the direction of forward wheel rotation. The master link is the most critical part affecting the security of the drive chain. Master links are reusable if they remain in excellent condition, but it is recommended that a new master link retaining clip be installed whenever the drive chain is reassembled.
7. Recheck chain slack and adjust if necessary.

Lubrication

Commercially prepared drive chain lubricants may be purchased at most motorcycle shops and should be used in preference to motor oil. Pro Honda Chain Lube or an equivalent, or SAE 80 or 90 gear oil is recommended.

Saturate each chain joint so that the lubricant penetrates the space between adjacent surfaces of the link plates and rollers.

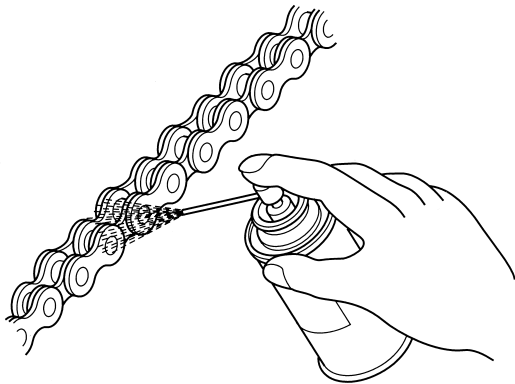

DRIVE CHAIN SLIDERS

1. Check the chain slider for wear. If the wear is $\frac{3}{16}$ in (5 mm) or more, replace it.

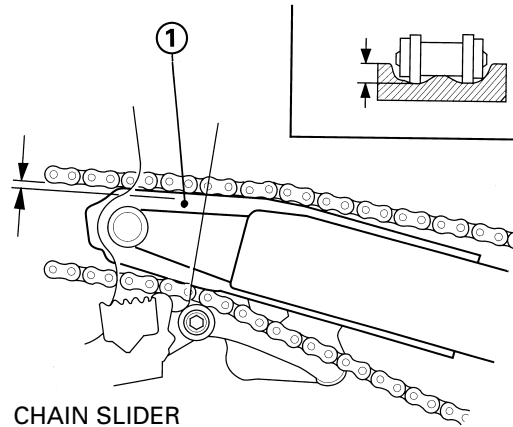

(1) CHAIN SLIDER

2. Check the chain guide slider for wear. Replace the guide slider if the chain is visible through the wear inspection window.

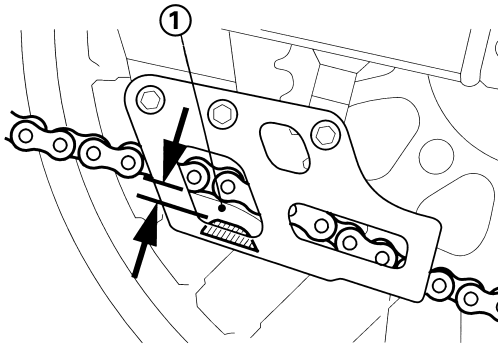

(1) CHAIN GUIDE SLIDER

DRIVE CHAIN ROLLERS

Check the drive chain rollers for wear. Replace if necessary.

SERVICE LIMIT:
UPPER ROLLER: 1.5 in (39 mm)
LOWER ROLLER: 1.5 in (39 mm)

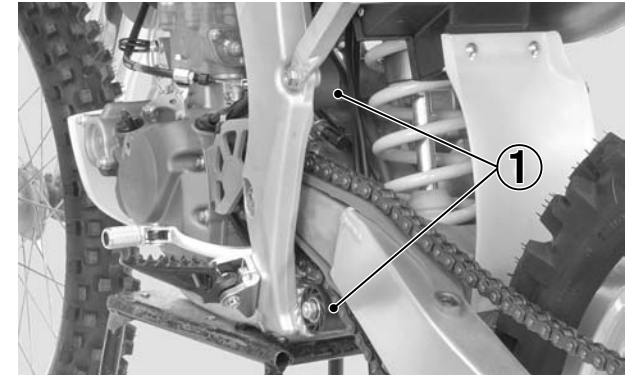

(1) DRIVE CHAIN ROLLERS

NOTE:

- If the drive chain roller removed, install the drive chain roller with its " " mark side facing out.

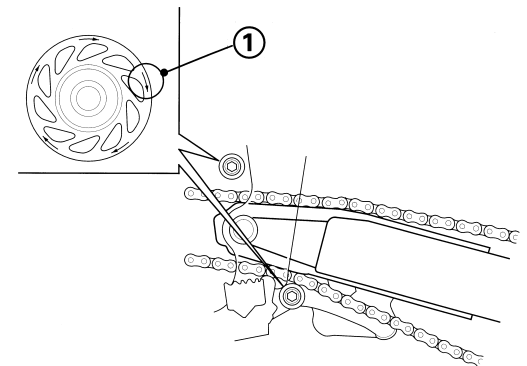

(1) " " MARK

Install the drive chain rollers as follows:

- Upper: Green
- Lower: Black

DRIVEN SPROCKET

Check the driven sprocket nut torque values after each race.

TORQUE: 24 lbf·ft (32 N·m, 3.3 kgf·m)

EXHAUST PIPE/MUFFLER

Inspection

1. Check the flange bolts for tightness.
2. Check the exhaust pipe and muffler for cracks or deformation.
A damaged exhaust pipe and muffler may reduce engine performance.

Muffler Removal

1. Remove the seat bolt, collar, side cover bolt, collar and right side cover.

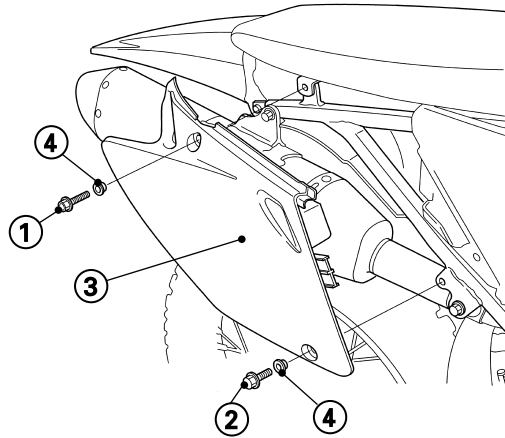

- (1) SEAT BOLT
- (2) SIDE COVER BOLT
- (3) RIGHT SIDE COVER
- (4) COLLARS

2. Loosen the muffler clamp bolt.
3. Remove the muffler A bolt, muffler B bolt/washer and muffler.

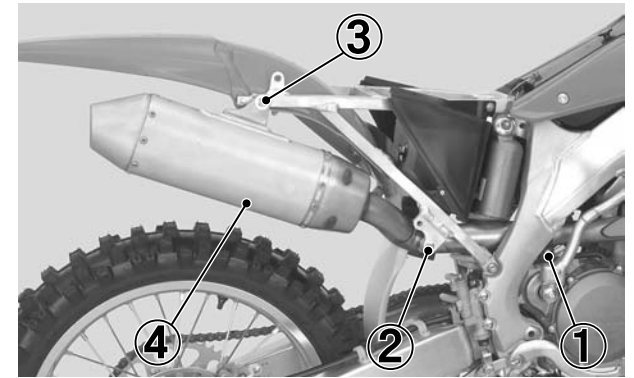

- (1) MUFFLER CLAMP BOLT
- (2) MUFFLER A BOLT
- (3) MUFFLER B BOLT/WASHER
- (4) MUFFLER

4. SERVICE AND MAINTENANCE

Muffler Installation

1. Remove the gasket.
2. Install the muffler clamp and new gasket to the exhaust pipe.

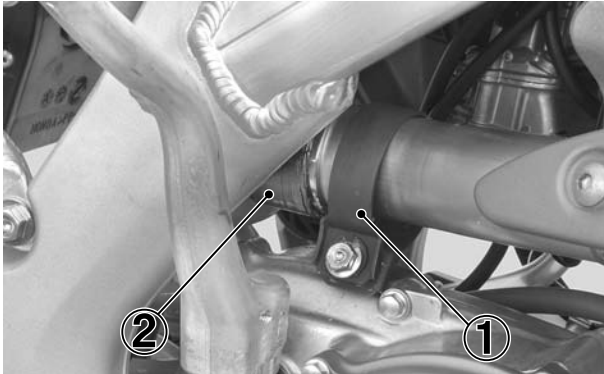

(1) MUFFLER CLAMP (2) GASKET

3. Install the muffler.
4. Install the muffler clamp by aligning the tab of the muffler clamp with the cut-out of the muffler.

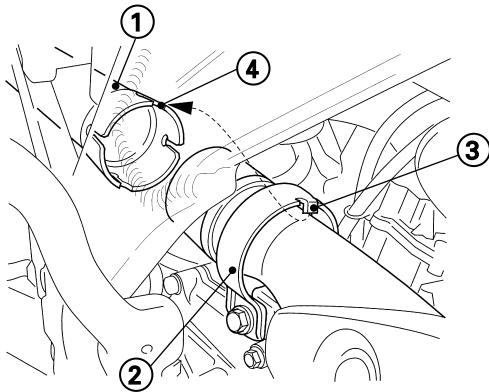

(1) MUFFLER (2) MUFFLER CLAMP
(3) TAB (4) CUT-OUT

5. Tighten the muffler B bolt and muffler A bolt.

TORQUE: 16 lbf·ft (22 N·m, 2.2 kgf·m)

6. Tighten the muffler clamp bolt.

TORQUE: 15 lbf·ft (21 N·m, 2.1 kgf·m)

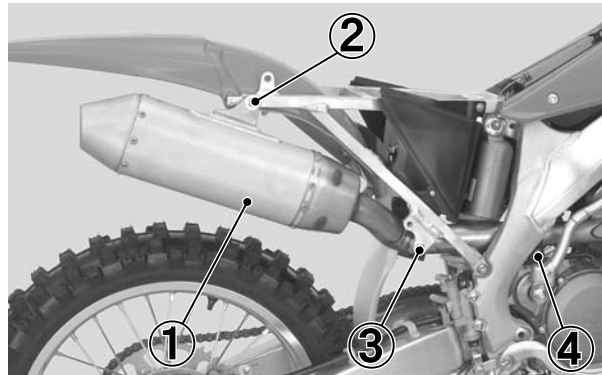

(1) MUFFLER
(2) MUFFLER B BOLT
(3) MUFFLER A BOLT
(4) MUFFLER CLAMP BOLT

7. Install the right side cover, collar and side cover bolt.
8. Install the collar and seat bolt.

TORQUE: 16 lbf·ft (22 N·m, 2.2 kgf·m)

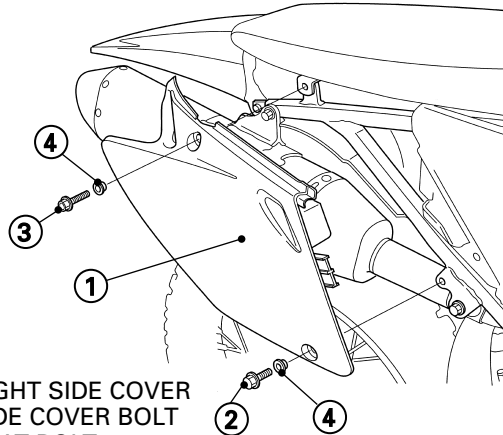

(1) RIGHT SIDE COVER
(2) SIDE COVER BOLT
(3) SEAT BOLT
(4) COLLARS

Exhaust Pipe Removal

1. Remove the muffler (page 55).
2. Remove the exhaust pipe joint nuts, exhaust pipe and exhaust pipe gasket.

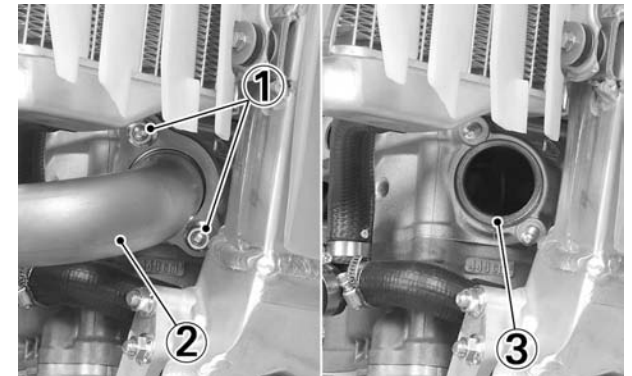

(1) EXHAUST PIPE JOINT NUTS
(2) EXHAUST PIPE
(3) EXHAUST PIPE GASKET

Exhaust Pipe Installation

1. Install a new exhaust pipe gasket, exhaust pipe and exhaust pipe joint nuts and tighten to the specified torque.

TORQUE: 15 lbf·ft (21 N·m, 2.1 kgf·m)

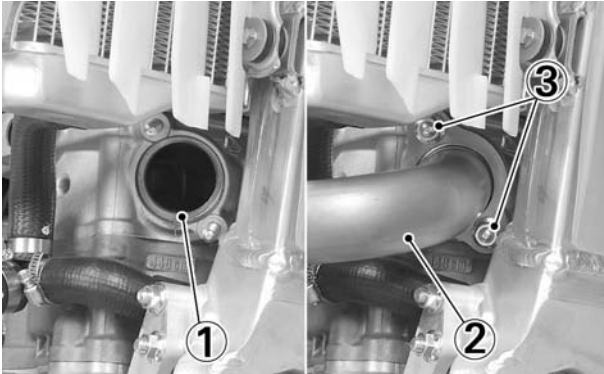

- (1) EXHAUST PIPE GASKET
- (2) EXHAUST PIPE
- (3) EXHAUST PIPE JOINT NUTS

2. Install the muffler (page 56).

CONTROL CABLES

Lubrication

Periodically, disconnect the throttle, clutch and hot start cables at their upper ends. Thoroughly lubricate the cable pivot points and the inside of clutch cable end adjuster with a commercially available cable lubricant. Be certain that the throttle cable has no kinks or other damage so the throttle slide will return properly.

4. SERVICE AND MAINTENANCE

NUTS, BOLTS, FASTENERS

Check and tighten nuts, bolts, and fasteners before every outing.

Engine

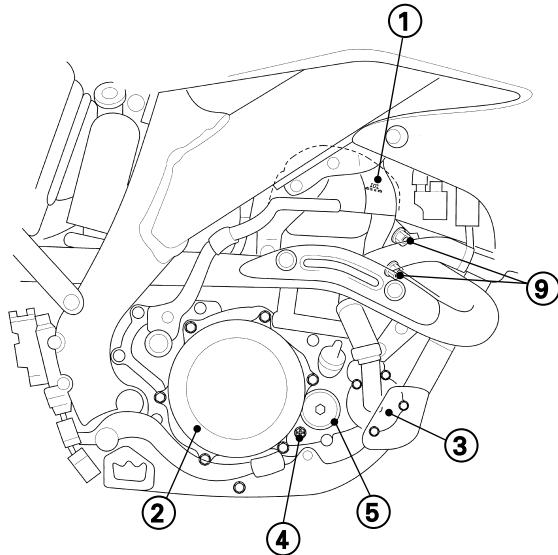
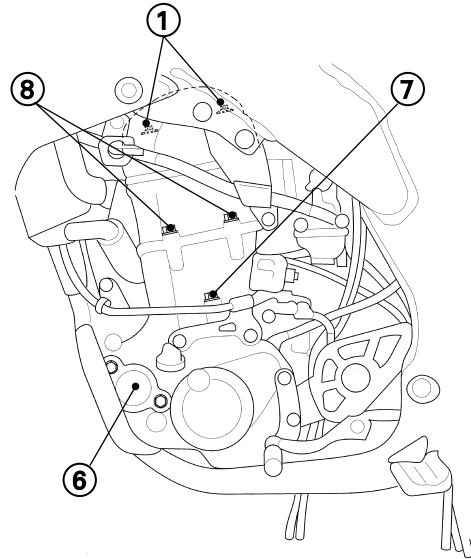

| | Item | Torque | | | Remarks |
|---|-----------------------------|--------|-----|-------|---------|
| | | lbf-ft | N·m | kgf·m | |
| | ENGINE | | | | |
| 1 | Cylinder head cover | 7 | 10 | 1.0 | |
| 2 | Clutch cover | 7 | 10 | 1.0 | |
| 3 | Water pump cover | 7 | 10 | 1.0 | |
| 4 | Transmission oil check bolt | 7 | 10 | 1.0 | |
| 5 | Crankshaft hole cap | 11 | 15 | 1.5 | |
| 6 | Oil filter cover | 9 | 12 | 1.2 | |
| 7 | Cylinder bolt | 7 | 10 | 1.0 | |
| 8 | Cylinder head bolt | 7 | 10 | 1.0 | |
| 9 | Exhaust pipe joint nut | 15 | 21 | 2.1 | |

Frame

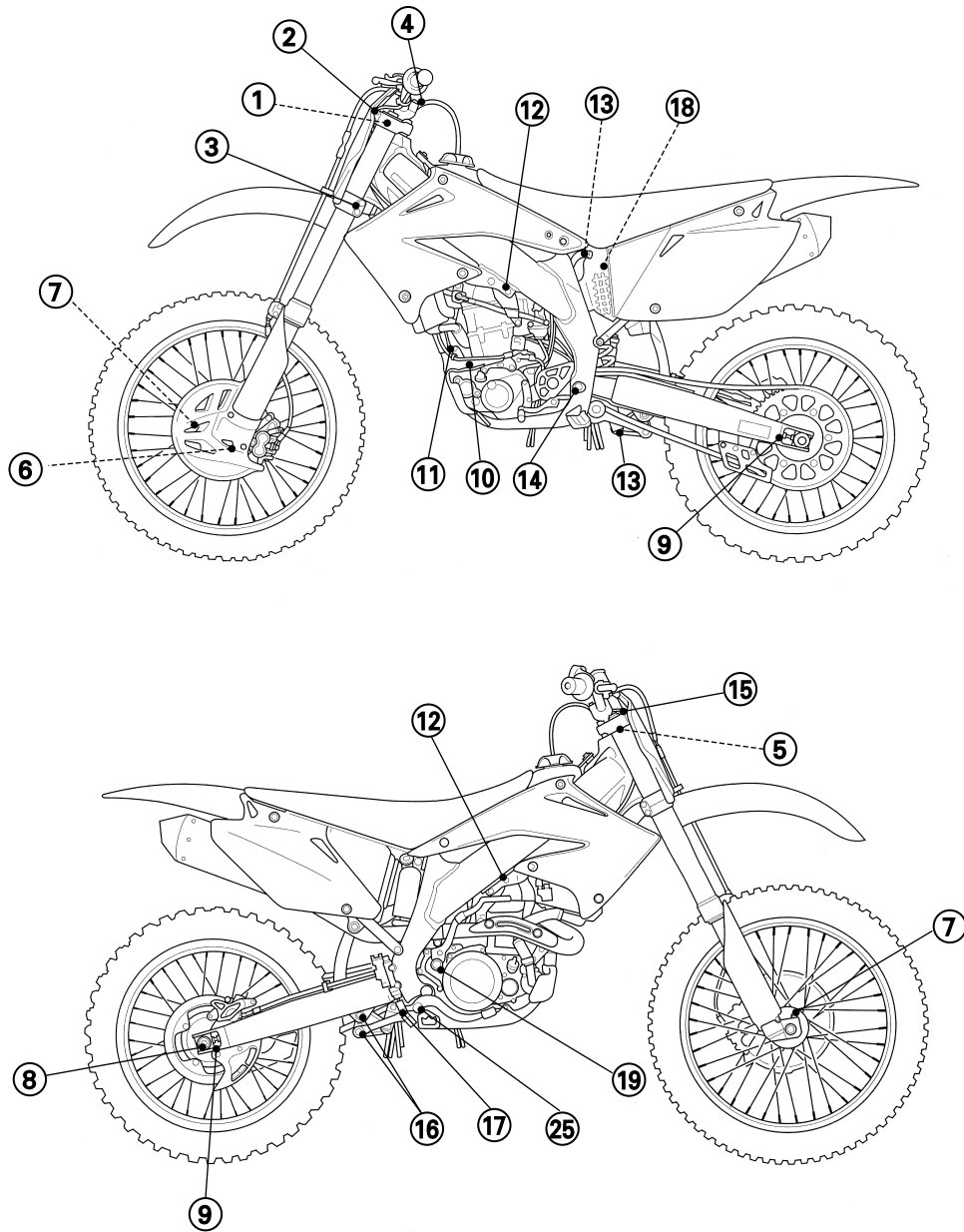

| Item | Torque | | | Remarks | |
|--------------|-------------------|-----|-------|-----------|-----------|
| | lbf-ft | N·m | kgf·m | | |
| FRAME | | | | | |
| 1 | 80 | 108 | 11.0 | | |
| 2 | 17 | 23 | 2.3 | | |
| 3 | 15 | 21 | 2.1 | | |
| 4 | 16 | 22 | 2.2 | | |
| 5 | 33 | 44 | 4.5 | | |
| 6 | 65 | 88 | 9.0 | | |
| 7 | 14 | 20 | 2.0 | | |
| 8 | 94 | 127 | 13.0 | NOTE 4 | |
| 9 | 20 | 26 | 2.7 | NOTE 5 | |
| 10 | 40 | 54 | 5.5 | | |
| 11 | | | | | |
| | (engine side) | 40 | 54 | 5.5 | |
| | (frame side) | 20 | 26 | 2.7 | |
| 12 | | | | | |
| | (engine side) | 40 | 54 | 5.5 | |
| | (frame side) | 20 | 26 | 2.7 | |
| 13 | 33 | 44 | 4.5 | NOTE 4 | |
| | (lower) | 33 | 44 | 4.5 | NOTE 4 |
| 14 | 65 | 88 | 9.0 | NOTE 4 | |
| 15 | 25 | 34 | 3.5 | | |
| | (fork cap) | 22 | 29 | 3.0 | |
| 16 | | | | | |
| | (swingarm side) | 38 | 52 | 5.3 | NOTE 2, 4 |
| | (shock link side) | 38 | 52 | 5.3 | NOTE 2, 4 |
| 17 | 38 | 52 | 5.3 | NOTE 2, 4 | |
| 18 | 33 | 44 | 4.5 | | |
| 19 | 28 | 38 | 3.9 | | |

- NOTES:
1. Apply Honda Thread Lock or an equivalent to the threads.
 2. Apply oil to the threads and flange surface.
 3. Stake.
 4. U-nut.
 5. UBS nut.
 6. SH bolt.
 7. Alock bolt.

4. SERVICE AND MAINTENANCE

Frame

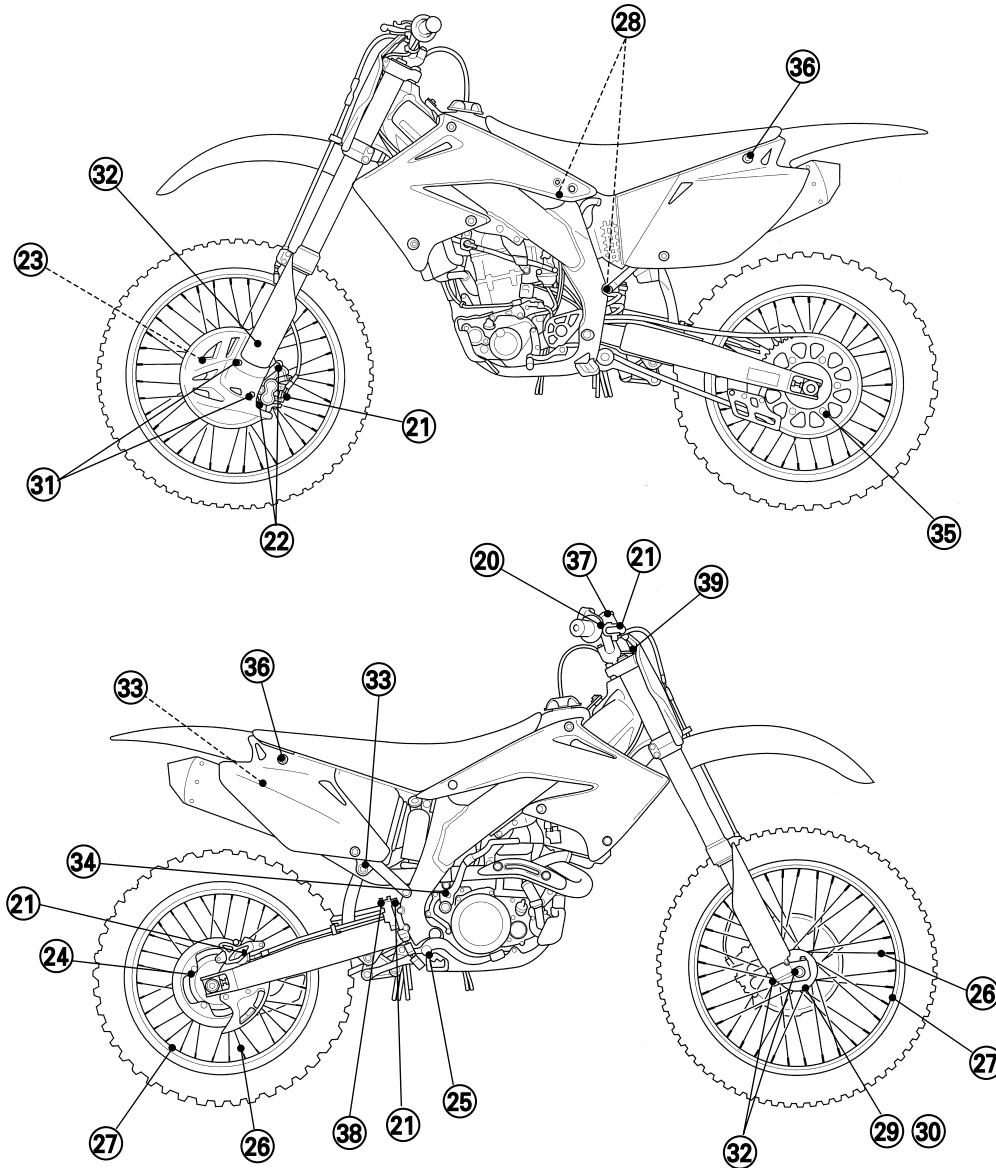

| Item | Torque | | | Remarks |
|--------------|--------|-----|-------|---------|
| | lbf-ft | N·m | kgf·m | |
| FRAME | | | | |
| 20 | 7 | 9.8 | 1.0 | |
| 21 | 25 | 34 | 3.5 | |
| 22 | 22 | 30 | 3.1 | NOTE 1 |
| 23 | 12 | 16 | 1.6 | NOTE 4 |
| 24 | 12 | 16 | 1.6 | NOTE 4 |
| 25 | 20 | 26 | 2.7 | |
| 26 | 2.7 | 3.7 | 0.38 | |
| 27 | 9.4 | 13 | 1.3 | |
| 28 | 22 | 30 | 3.1 | |
| | 36 | 49 | 5.0 | |
| 29 | 51 | 69 | 7.0 | |
| 30 | 16 | 22 | 2.2 | |
| 31 | 9 | 13 | 1.3 | |
| 32 | 5.1 | 6.9 | 0.7 | NOTE 1 |
| 33 | | | | |
| | 16 | 22 | 2.2 | |
| | 16 | 22 | 2.2 | |
| 34 | 15 | 21 | 2.1 | |
| 35 | 24 | 32 | 3.3 | NOTE 4 |
| 36 | 20 | 26 | 2.7 | |
| 37 | 1.1 | 1.5 | 0.15 | |
| 38 | 1.1 | 1.5 | 0.15 | |
| 39 | 0.9 | 1.2 | 0.12 | |

- NOTES:
1. Apply Honda Thread Lock or an equivalent to the threads.
 2. Apply oil to the threads and flange surface.
 3. Stake.
 4. U-nut.
 5. UBS nut.
 6. SH bolt.
 7. Alock bolt.

5. CARBURETOR ADJUSTMENT

CARBURETOR

The carburetor used on your CRF will seldom experience trouble with the standard settings under average load, and average climatic and barometric conditions. However, to fine tune the engine's power output, the carburetor may require adjustments for specific racing conditions. To change the carburetor settings, observe the following instructions.

Construction

• Cold Start Circuit

A very rich mixture must be delivered to the cylinder when cold engine is being started. When the choke knob is pulled out, fuel is metered by the starter jet and is mixed with air from the air passage (located above the throttle valve) to provide a rich mixture for starting. The mixture discharges through the orifice into the cylinder.

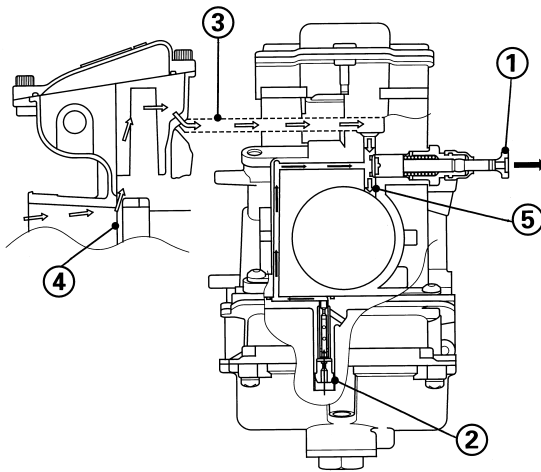

- (1) CHOKE KNOB
- (2) STARTER JET
- (3) AIR PASSAGE
- (4) THROTTLE VALVE
- (5) ORIFICE

• Hot Start Circuit

A lean mixture must be delivered to the cylinder when hot engine is being started. When the hot start lever is pulled back, the hot start valve opens, allowing air to be supplied to the main bore through the hot start air passage. This extra air enters the air-fuel mixture from the slow circuit resulting in a lean condition.

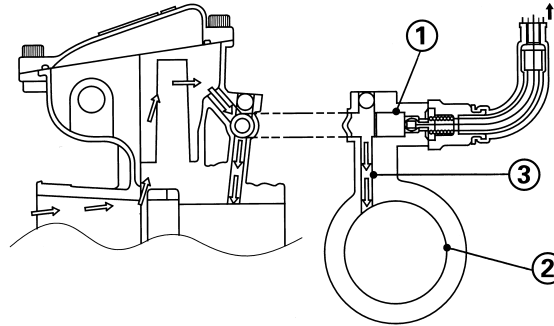

- (1) HOT START VALVE
- (2) MAIN BORE
- (3) HOT START AIR PASSAGE

• Accelerator Pump Circuit

The accelerator pump circuit operates when the throttle is opened. As the throttle valve opens, the pump rod depresses the diaphragm. At this time, the inlet check valve is shut resulting in a sharp increase in pressure in the pump chamber. The outlet check valve then opens, supplying fuel to the main bore via the accelerator nozzle.

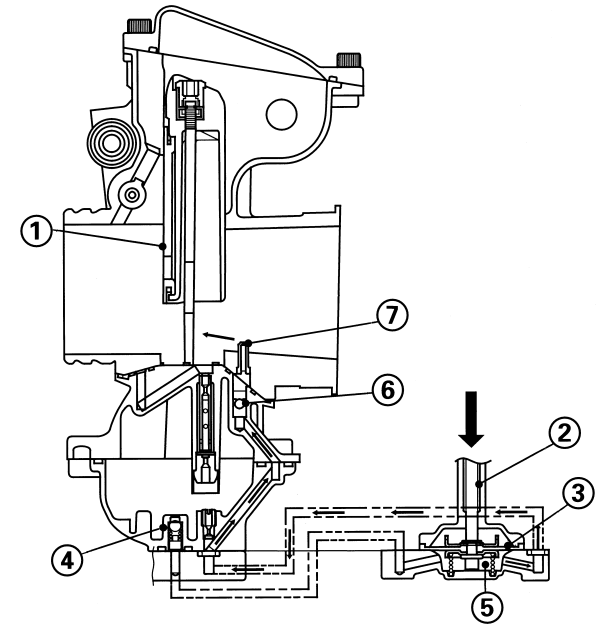

- (1) THROTTLE VALVE
- (2) PUMP ROD
- (3) DIAPHRAGM
- (4) INLET CHECK VALVE
- (5) PUMP CHAMBER
- (6) OUTLET CHECK VALVE
- (7) ACCELERATOR NOZZLE

5. CARBURETOR ADJUSTMENT

• Slow Circuit

Fuel is metered by the slow jet and mixed with air from the air passage. The mixture enters the venturi through the bypass and pilot outlet that has been metered by the pilot screw.

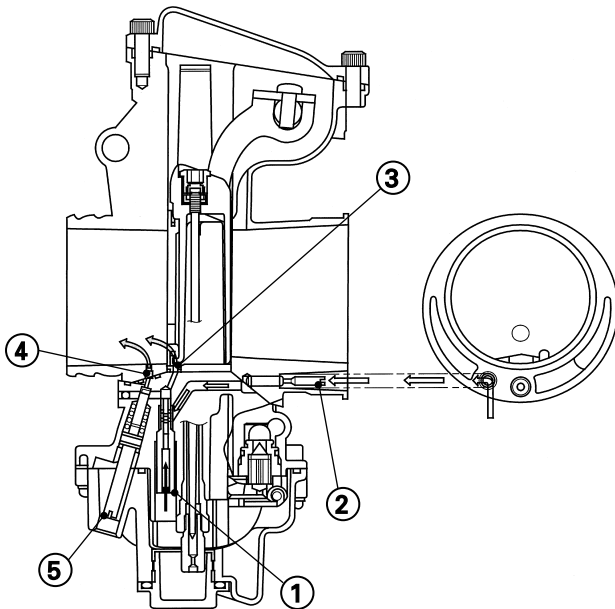

- (1) SLOW JET
- (2) AIR PASSAGE
- (3) BYPASS
- (4) PILOT OUTLET
- (5) PILOT SCREW

• Main Circuit

Fuel is metered by the main jet, jet needle and needle jet. It is then mixed with air coming from the air jet and enters the venturi past the needle jet.

• Baffle Plate

The baffle plate prevents foaming of fuel or abnormal fuel level around the main jet.

• Float Bowl

The float and float valve operate to maintain a constant level of fuel in the float bowl.

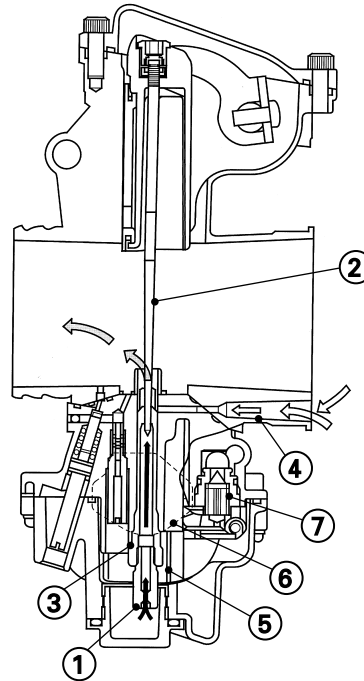

- (1) MAIN JET
- (2) JET NEEDLE
- (3) NEEDLE JET
- (4) AIR JET
- (5) BAFFLE PLATE
- (6) FLOAT
- (7) FLOAT VALVE

Disassembly/Assembly

1. Turn the fuel valve OFF.
2. Drain the remaining fuel in the float bowl by removing the float bowl plug.

▲WARNING

- **Removing the float bowl plug will allow the fuel in the float bowl to drain. Do not remove if engine is hot.**
- **Gasoline is extremely flammable and is explosive under certain conditions. Perform this operation in a well-ventilated area with the engine stopped. Do not smoke or allow flames or sparks in the area where gasoline is drained or stored and where the fuel tank is refueled.**

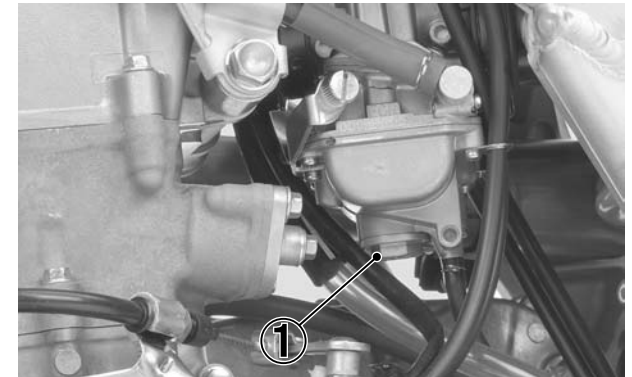

(1) FLOAT BOWL PLUG

3. Install the float bowl plug.

4. Disconnect the fuel line.
5. Remove the fuel tank (page 17).
6. Remove the sub frame (page 19).
7. Loosen the intake band screw.

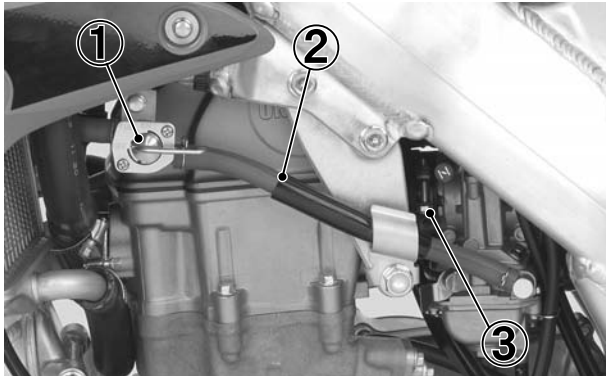

- (1) FUEL VALVE
- (2) FUEL LINE
- (3) INTAKE BAND SCREW

8. Disconnect the throttle sensor connector.
9. Remove the carburetor.

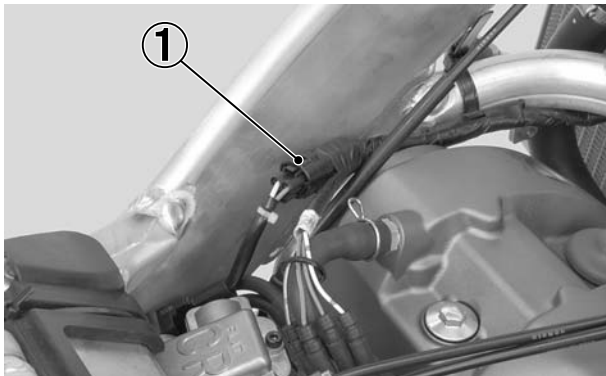

- (1) THROTTLE SENSOR CONNECTOR

10. Remove the hot start cable holder.

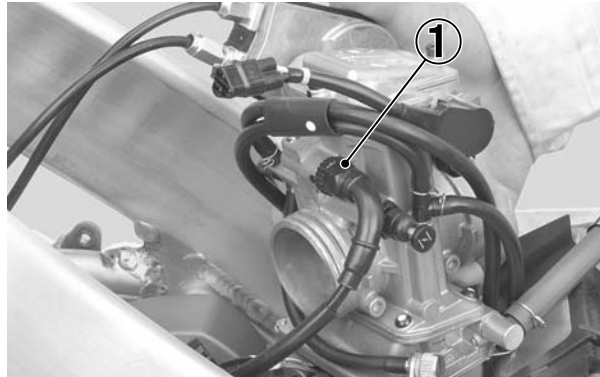

- (1) HOT START CABLE HOLDER

11. Remove the hot start valve, spring and hot start cable holder from hot start cable.

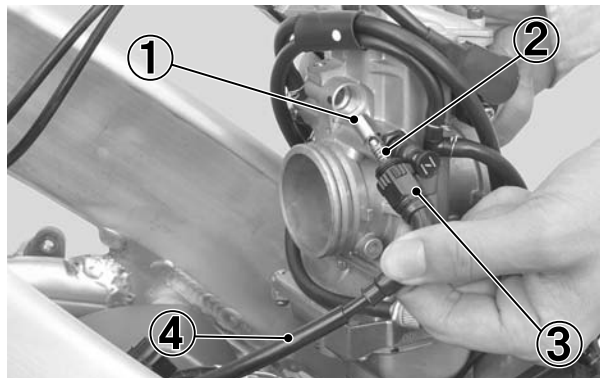

- (1) HOT START VALVE
- (2) SPRING
- (3) HOT START CABLE HOLDER
- (4) HOT START CABLE

12. Remove the throttle drum cover bolt and throttle drum cover.

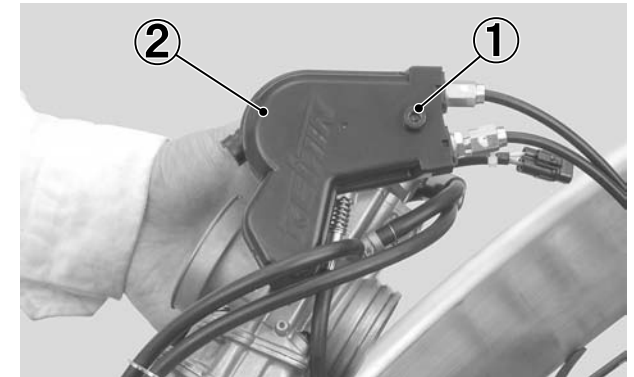

- (1) THROTTLE DRUM COVER BOLT
- (2) THROTTLE DRUM COVER

13. Remove the throttle cables by loosening the throttle cable lock nuts.

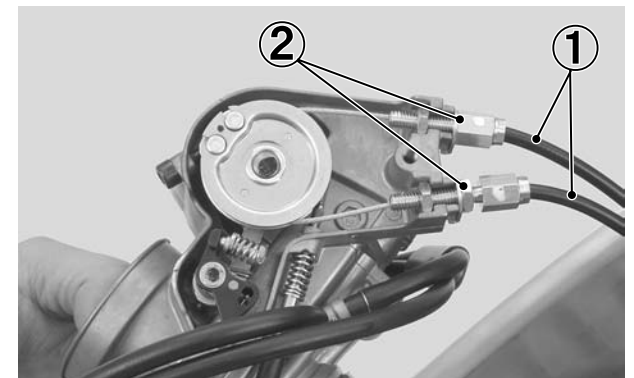

- (1) THROTTLE CABLES
- (2) THROTTLE CABLES LOCK NUTS

5. CARBURETOR ADJUSTMENT

14. Remove the carburetor top bolts and carburetor top.

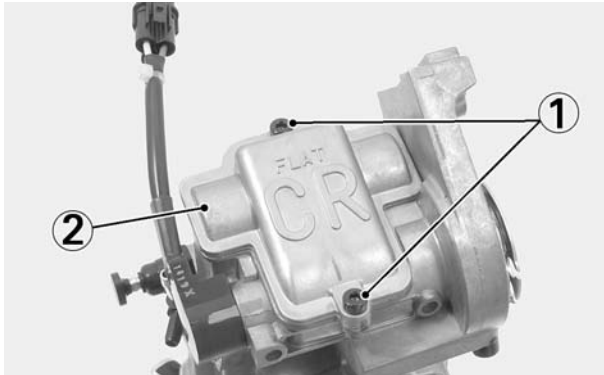

- (1) CARBURETOR TOP BOLTS
- (2) CARBURETOR TOP

15. Remove the jet needle holder and jet needle from the throttle valve.

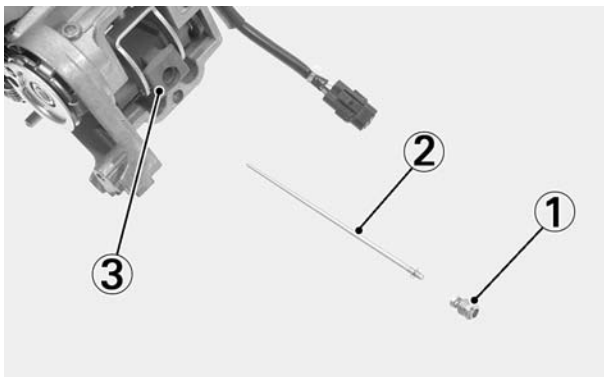

- (1) JET NEEDLE HOLDER
- (2) JET NEEDLE
- (3) THROTTLE VALVE

16. Remove the link arm set screw.
When installing the link arm set screw, apply a locking agent to the link arm set screw threads.

17. Remove the throttle valve, throttle valve roller and floating valve.

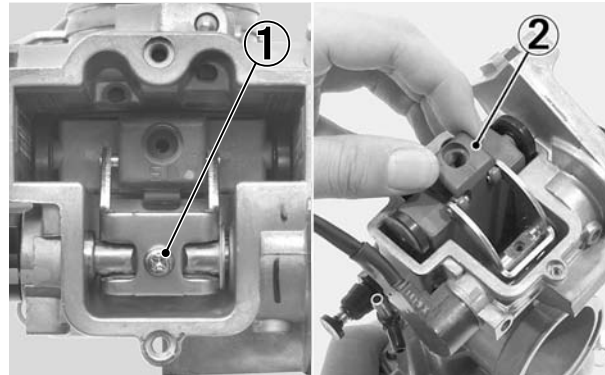

- (1) LINK ARM SET SCREW
- (2) THROTTLE VALVE
- (3) THROTTLE VALVE ROLLER
- (4) FLOATING VALVE

When installing the floating valve onto the throttle valve make sure the floating valve's flat side faces out and the hole faces down.

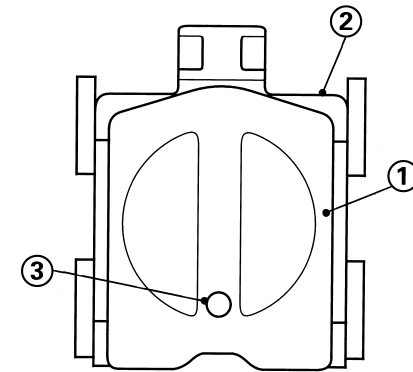

- (1) FLOATING VALVE
- (2) THROTTLE VALVE
- (3) HOLE

18. Remove the accelerator pump cover screws and accelerator pump cover.

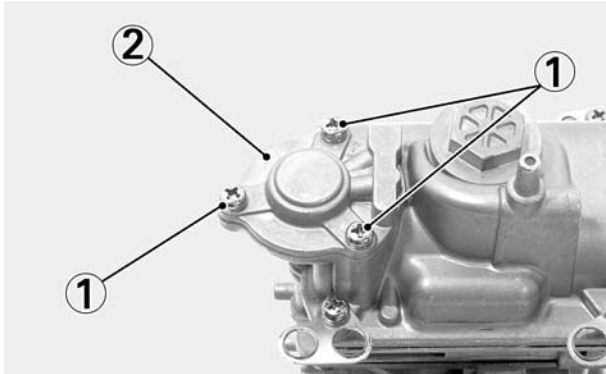

- (1) ACCELERATOR PUMP COVER SCREWS
- (2) ACCELERATOR PUMP COVER

19. Remove the D-ring, O-ring spring and diaphragm. Clean the diaphragm. When installing the D-ring into the accelerator pump cover make sure the D-rings flat-side faces down, away from the float bowl.

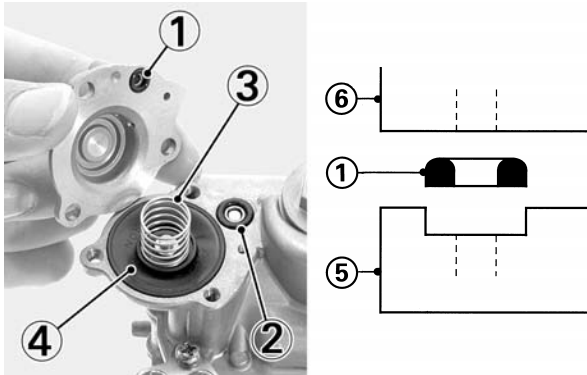

- (1) D-RING
- (2) O-RING
- (3) SPRING
- (4) DIAPHRAGM
- (5) ACCELERATOR PUMP COVER
- (6) FLOAT BOWL

20. Remove the holder screw, throttle stop screw holder, float bowl screws, tube guides and float bowl.

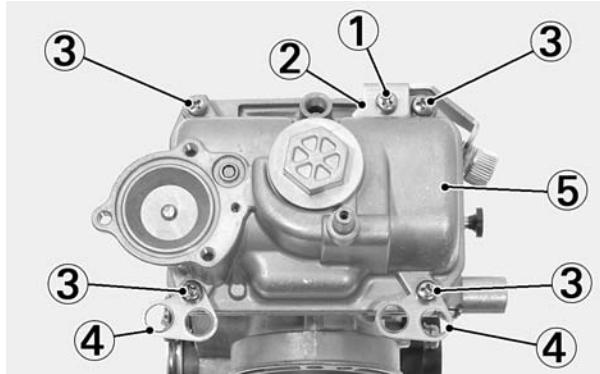

- (1) HOLDER SCREW
- (2) THROTTLE STOP SCREW HOLDER
- (3) FLOAT BOWL SCREWS
- (4) TUBE GUIDES
- (5) FLOAT BOWL

21. Remove the pump rod. Clean the pump rod and rod passage. Install the pump rod into the link lever. Push the rod forcibly into the link lever until it snaps into place.

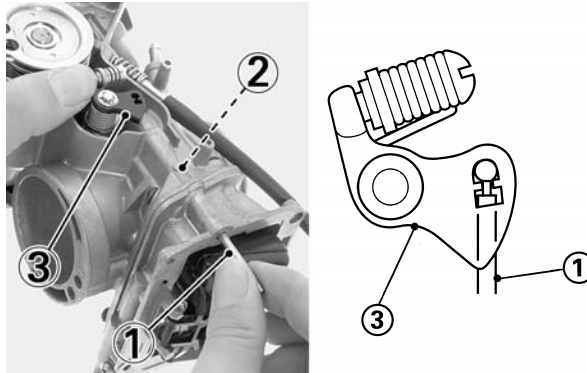

- (1) PUMP ROD
- (2) ROD PASSAGE
- (3) LINK LEVER

22. Measure the float level with the float tab just contacting the float valve and the carburetor intake facing up. The float level should be 0.31 in (8.0 mm). Adjust the float level by bending the float tab carefully.

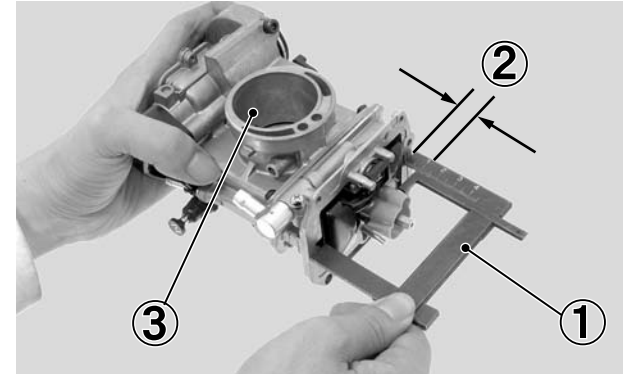

- (1) FLOAT LEVEL GAUGE
- (2) FLOAT LEVEL
- (3) CARBURETOR INTAKE

23. Remove the leak jet from the float bowl. Clean the leak jet.

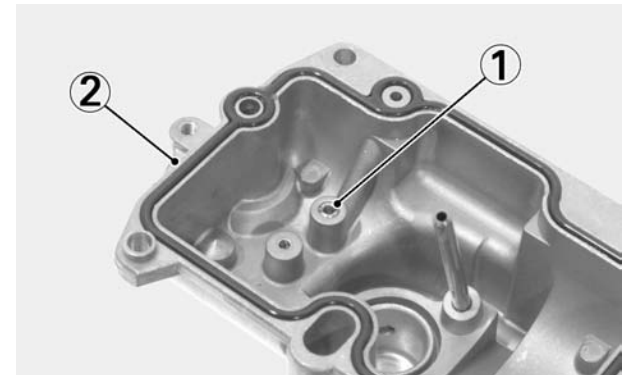

- (1) LEAK JET
- (2) FLOAT BOWL

5. CARBURETOR ADJUSTMENT

To assemble, reverse the disassembly procedures.
To install the carburetor, reverse the removal procedures.

NOTE:

- After installing the carburetor, adjust the throttle cable free play and hot start cable free play.
- After installing the carburetor, check the air vent tubes and overflow hose for kinking or pinching and correct routing as necessary.

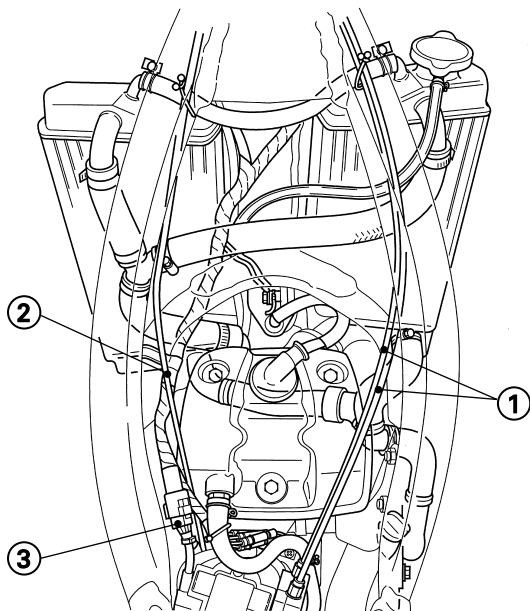

- (1) THROTTLE CABLES
- (2) HOT START CABLE
- (3) THROTTLE SENSOR CONNECTOR

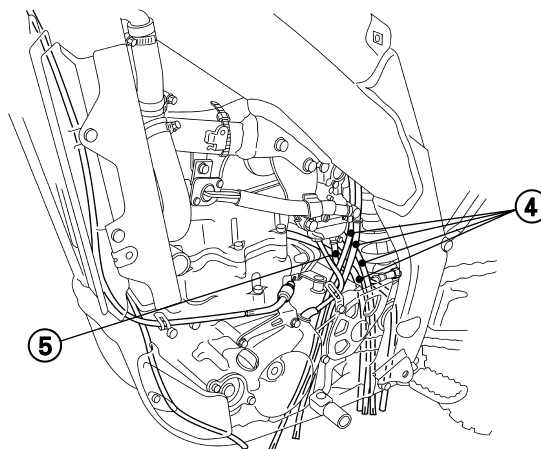
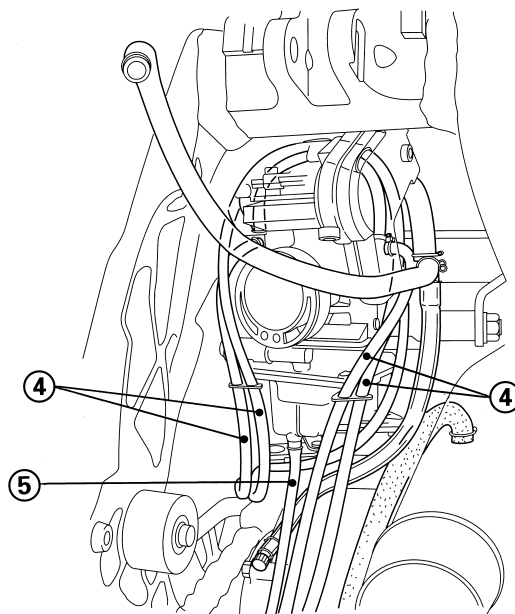

- (4) AIR VENT HOSES
- (5) OVERFLOW HOSE

Pre-adjustment Checks

Before adjusting carburetor settings, check the following:

1. air cleaner condition (page 27)
2. air leaks
3. ignition timing
4. float level
5. clogged carburetor jets
6. spark plug fouling or improper heat range

If the above check out, then, adjust the carburetor for your specific racing conditions. Engine response and appearance of the firing end of a spark plug are highly indicative of the engine condition.

Refer to the list on page 9 for the optional carburetor parts.

Adjustment Procedure

1. Turn the pilot screw in until it is lightly seated and record the number of turns.
Turn the pilot screw out the same number of turns.
2. Warm up the engine.
3. Adjust the engine idle speed (page 26).
4. Make two or three laps of a course with the standard or corrected jetting (see page 70) and spark plug. Note engine acceleration and other engine conditions in relation to throttle opening. Verify carburetion by removing the spark plug and reading its firing end (page 25, 70). It may take more than two or three laps to get a good spark plug reading with a new spark plug.
5. Change carburetor settings or select suitable carburetor jets, taking into consideration the engine conditions and factors for temperature and attitude (page 70).
6. Adjust the pilot screw as required.

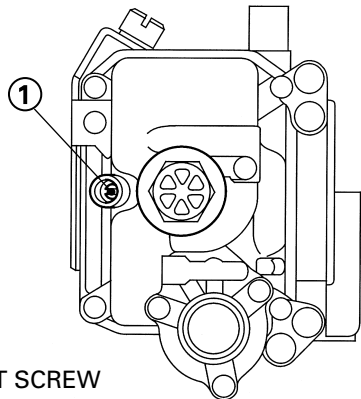
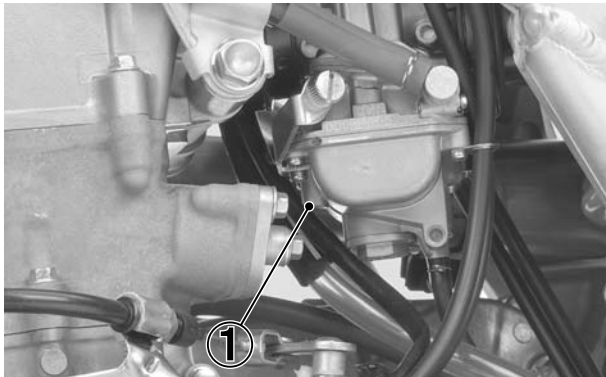

(1) PILOT SCREW

7. If you've determined that the main and slow jets must be changed, you must rotate the carburetor and remove the float bowl plug.

▲WARNING

- **Removing the float bowl plug will allow the fuel in the float bowl to drain. Do not remove if engine is hot.**
 - **Gasoline is extremely flammable and is explosive under certain conditions. Perform this operation in a well-ventilated area with the engine stopped. Do not smoke or allow flames or sparks in the area where gasoline is drained or stored and where the fuel tank is refueled.**
8. Turn the fuel valve OFF, and disconnect the fuel line from the fuel valve.
 9. Loosen the connecting and intake tube band screw. Rotate the carburetor.
 10. Remove the float bowl plug.

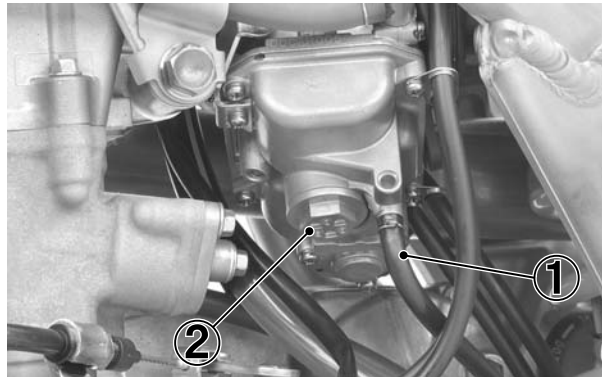

(1) OVERFLOW HOSE
(2) FLOAT BOWL PLUG

11. Change the main jet and slow jet as required.

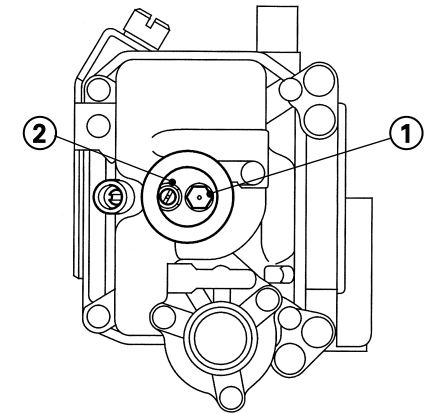
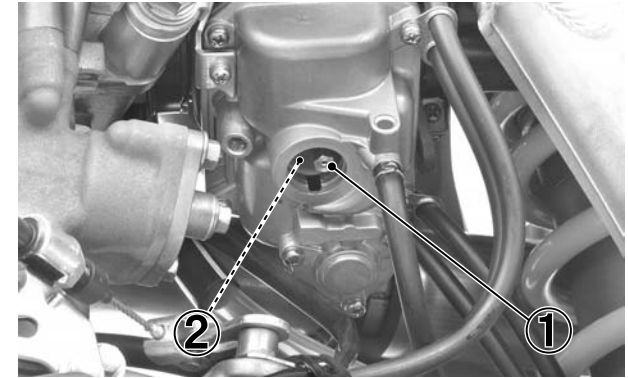

(1) MAIN JET
(2) SLOW JET

12. Reinstall the float bowl plug.

5. CARBURETOR ADJUSTMENT

13. Rotate the carburetor and align the lug on the carburetor with the slot on the intake tube.

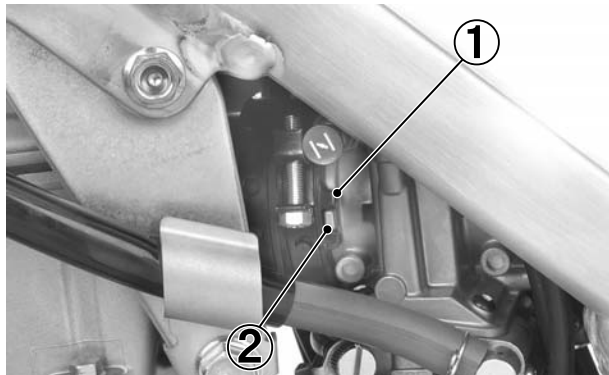

(1) SLOT (2) LUG

14. Tighten the connecting and intake tube band screws.
15. Connect the fuel line.
16. If you've determined that the jet needle or clip position of jet needle must be changed, you must remove the carburetor top.
17. Remove the fuel tank (page 17).

18. Remove the carburetor top bolts and carburetor top.

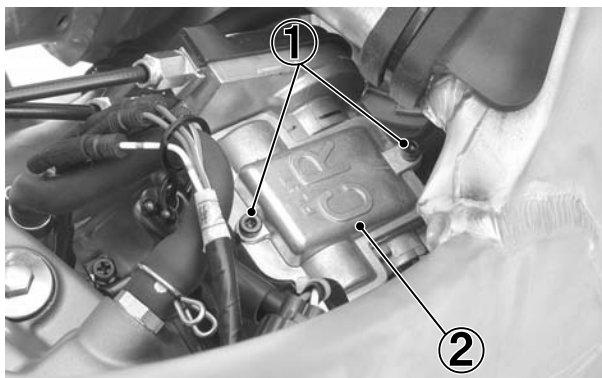

(1) CARBURETOR TOP BOLTS
(2) CARBURETOR TOP

19. Remove the jet needle holder and jet needle from the throttle valve.

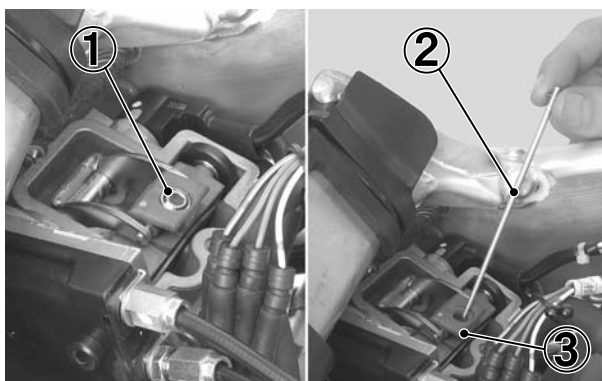

(1) JET NEEDLE HOLDER
(2) JET NEEDLE
(3) THROTTLE VALVE

20. Change the clip position of jet needle or jet needle as required.

21. Reinstall the jet needle, jet needle holder carburetor top and carburetor top bolts.

22. Install the fuel tank (page 18).

23. Start the engine.

If the engine idle speed is too high or too low or engine is not idling, adjust the engine idle speed (page 26).

24. Repeat steps 4 through 23 until the engine gives maximum power with the correct spark plug reading. It is always better to jet a little rich than a little lean. It is advisable to record the settings, course conditions, lap times, and climatic and barometric conditions for future reference.

Circuit Adjustments

The carburetor has several major circuits, each providing the fuel/air mixture over a given portion of throttle valve opening. These major circuits overlap as shown below.

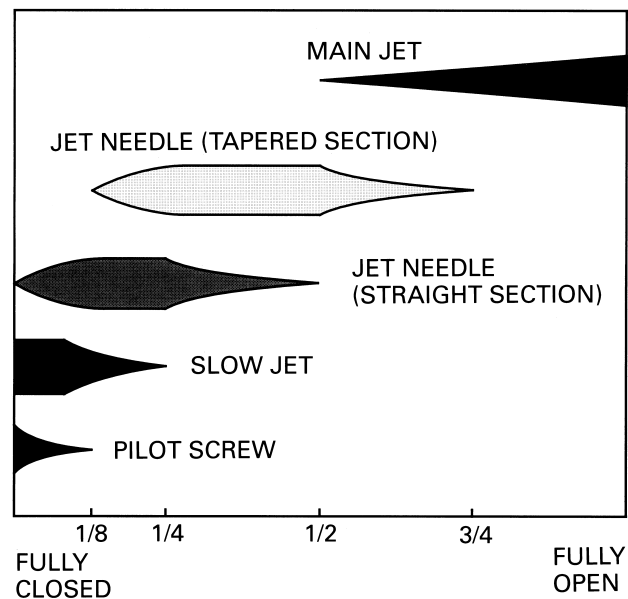

• Main Jet

The main jet affects fuel/air ratio from half to full throttle (4/4). The size should be reduced at higher altitudes.

NOTE:

- Honda carburetor jet sizes are numbered in increments of 2 or 3. When changing the main jet size, increase or decrease it gradually until the desired jetting is obtained. Because Honda jet size numbers do not correspond with other carburetor manufacturer's jet size numbers, use genuine 2004 Honda CRF450R jets.

• Jet Needle

The jet needle controls fuel/air mixture over fully closed to 3/4 throttle. The straight section affects throttle response at smaller throttle openings. By changing the position of the clip in its groove, you can improve acceleration at medium low and medium speed.

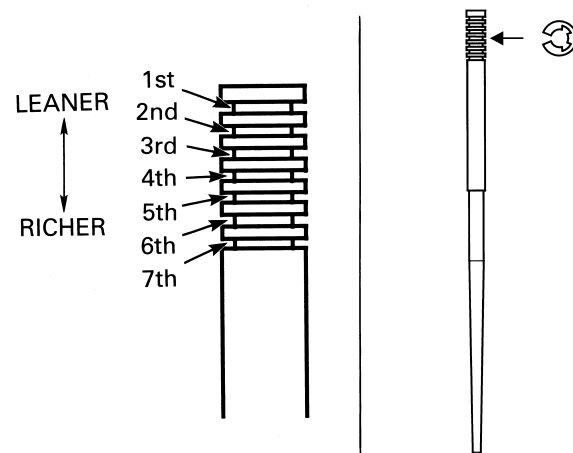

• Slow Jet and Pilot Screw

The slow jet and pilot screw affects fuel/air ratio over fully closed to 1/4 throttle.

Adjust the pilot screw to obtain the best off-idle performance.

- If the engine blubbers (rich) exiting a corner, turn the pilot screw clockwise to lean the mixture.
- If the engine surges (lean) exiting a corner, turn the pilot screw counter clockwise to richen the mixture.

NOTE:

- The minimum to maximum range of pilot screw adjustment is 1/2 to 2 1/2 turns out from the lightly seated position.
If you exceed 2 1/2 turns out, the next larger slow jet is needed.
If you are under 1/2 turns out, the next smaller slow jet is needed.

Carburetor Major Adjustments

NOTE:

- For the following recommendations to be accurate, you must use the standard jetting as a baseline. Also, don't change any of the settings until you've determined what changes are necessary.

Standard settings:

| | |
|-----------------------|--------------------|
| Pilot screw opening | - 1 1/2 turns out |
| Slow jet | - #42 |
| Jet needle | - NCYR |
| Needle clip position | - 4th groove |
| Main jet | - #165 |
| Float level | - 0.31 in (8.0 mm) |
| identification number | - FCR00C |

5. CARBURETOR ADJUSTMENT

All jetting is based on

- * Standard jetting
- * Unmodified Engine

| TEMPERATURE ALTITUDE | FAHR. | -21° ~ 0° | -1° ~ 20° | 19° ~ 40° | 39° ~ 60° | 59° ~ 80° | 79° ~ 100° | 99° ~ 120° |
|-----------------------------|---------------------------------|-----------------------------------|-----------------------------------|-----------------------------------|-----------------------------------|---|--|-----------------------------------|
| 10,000 ft to 7,500 ft | PS: SJ: JN: NC: MJ: | 1 1/2 42 NCYR 4th 165 | 1 1/2 42 NCYR 4th 162 | 1 1/4 42 NCYR 3rd 162 | 1 1/4 42 NCYR 3rd 160 | 1 1/4 40 NCYR 3rd 160 | 1 40 NCYR 3rd 158 | 1 40 NCYR 3rd 158 |
| 7,499 ft to 5,000 ft | PS: SJ: JN: NC: MJ: | 1 1/2 42 NCYR 4th 168 | 1 1/2 42 NCYR 4th 165 | 1 1/2 42 NCYR 4th 162 | 1 1/4 42 NCYR 3rd 162 | 1 1/4 42 NCYR 3rd 160 | 1 1/4 40 NCYR 3rd 160 | 1 40 NCYR 3rd 158 |
| 4,999 ft to 2,500 ft | PS: SJ: JN: NC: MJ: | 1 3/4 42 NCYR 5th 168 | 1 1/2 42 NCYR 4th 168 | 1 1/2 42 NCYR 4th 165 | 1 1/2 42 NCYR 4th 162 | 1 1/4 42 NCYR 3rd 162 | 1 1/4 42 NCYR 3rd 160 | 1 1/4 40 NCYR 3rd 160 |
| 2,499 ft to 1,000 ft | PS: SJ: JN: NC: MJ: | 1 3/4 45 NCYR 5th 170 | 1 3/4 42 NCYR 5th 168 | 1 1/2 42 NCYR 4th 168 | 1 1/2 42 NCYR 4th 165 | 1 1/2 42 NCYR 4th 162 | 1 1/4 42 NCYR 3rd 162 | 1 1/4 42 NCYR 3rd 160 |
| 999 ft to Sea Level | PS: SJ: JN: NC: MJ: | 1 3/4 45 NCYR 5th 170 | 1 3/4 45 NCYR 5th 170 | 1 3/4 42 NCYR 4th 168 | 1 1/2 42 NCYR 4th 168 | STANDARD 1 1/2 42 NCYR 4th 165 | JETTING 1 1/2 42 NCYR 4th 162 | 1 1/4 42 NCYR 3rd 162 |

Legend

- PS: Pilot Screw opening from fully seated
- SJ: Slow Jet
- JN: Jet Needle
- NC: Needle Clip position
- MJ: Main Jet

General changes due to temperature and altitude

| Condition | Mixture will be | Adjust to | Component affected |
|------------------|-----------------|-----------|-----------------------------|
| Cold temperature | Lean | Richen | Main jet (jet needle stage) |
| Warm temperature | Rich | Lean | |
| Dry air | Lean | Richen | |
| High humidity | Rich | Lean | |
| High altitude | Rich | Lean | |

TUNING FOR SPECIAL CONDITIONS

Once you've adjusted the carburetor for temperature and altitude, it shouldn't need major readjustment unless race conditions change drastically. However, there are some unique atmospheric conditions or race day situations that may require additional adjustments. They are as follows.

NOTE:

- To prevent engine damage, always adjust the main jet before adjusting the jet needle. Always choose the next richer jet if there is any doubt so there is a margin for safety.

- Main Jet**
- Go richer on the main jet, by one number, when: the track has a very long straightaway or uphill section, a high percentage of sand, or the track is muddy.
 - Go leaner on the main jet, by one number, when: it is very humid or raining, or it is hotter than 113 degrees F.

NOTE:

- After using the chart, and making any adjustments for special conditions, it shouldn't be necessary to go more than one jet size richer or leaner to fine tune your CRF. If larger jetting changes are necessary, check for air leaks, blocked or restricted exhaust or fuel systems, or a dirty air cleaner.

SPARK PLUG COLORING INDICATIONS

| | | |
|-------------|--|------------------|
| Normal | Dark brown to light tan color with dry electrode | |
| Overheating | Light gray or white color | Mixture is Lean* |
| Wet | Wet and sooty | Mixture is Rich |

Remember that in addition to improper jetting:

- * A lean condition can be caused by air leaks in the inlet tract.

The same simple throttle opening identification system used in the Break-In section of this manual can also be used to accurately identify where carburation problems occur, should they arise (See page 3).

6. SUSPENSION ADJUSTMENT

RACE SAG

Standard Race sag: 3.9 in (100 mm)

There are a series of adjustments that should be performed on a factory-new CRF; once after the pre-ride inspection, then again after initial break-in. First and foremost among these is the rear suspension Race Sag adjustment.

First. A Common Mistake

Due to the great absorption quality of the shock bump rubber, it is difficult for all but a few riders to notice when their CRF's suspension is bottoming out. Many riders think the damping or perhaps the leverage ratio is too harsh. In reality, they're running too little preload or a spring that's too soft and using only the last third of the stroke.

Setting your CRF's shock spring preload/Race Sag dimension according to the guidelines here will ensure correct adjustment and spring selection.

Shock Spring Preload And Race Sag Adjustment

The adjustment procedure that follows establishes the correct starting point for any suspension tuning. It guides you to both proper spring preload adjustment and spring selection for your specific needs. Damping adjustments are described elsewhere in this manual. The first step toward determining proper suspension adjustment is to set the rear spring preload so that the proper ride height, or Race Sag dimension, is achieved. For this adjustment procedure, the bike should be brought to normal racing weight-correct fuel, transmission oil and coolant levels.

First measure the Unloaded dimension when your CRF's is supported by a workstand without the left side cover and the rear wheel is off the ground. Measure the distance from the center of the rear fender mounting bolt to the center of the chain adjuster lock nut as illustrated here.

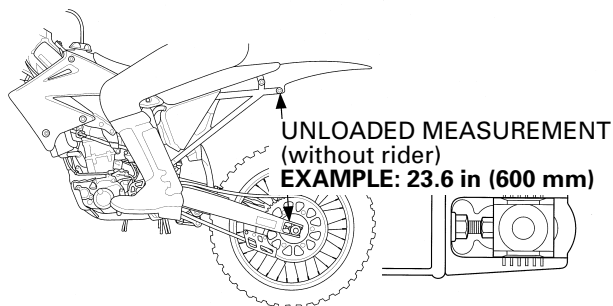

Next measure the Loaded dimension with the rider aboard, wearing all normal riding gear. Ask a buddy to steady the bike perfectly upright so you can put both feet on the pegs. You'll need another helper to measure. Bounce your weight on the seat a couple of times to help the suspension overcome any stiction and settle to a good reference point.

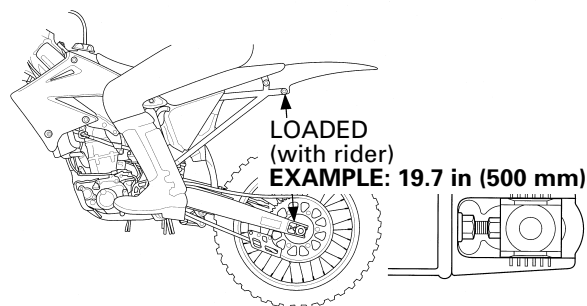

| | |
|-----------------|---------------------------|
| EXAMPLE: | |
| UNLOADED | = 23.6 in (600 mm) |
| - LOADED | = 19.7 in (500 mm) |
| RACE SAG | = 3.9 in (100 mm) |

The Race Sag dimension is the difference between the Unloaded and the Loaded measurements.

Standard Race Sag: 3.9 in (100 mm)

Adjust spring preload as necessary to obtain the correct handling results.

A Race Sag setting of 3.5 in (90 mm) improves turning ability for tight tracks at the cost of slightly reduced straight line stability. Setting this dimension 4.3 in (110 mm) improves stability on faster tracks with less turns, but reduces turning performance slightly.

Determining If You Have The Correct Spring

Next you must compare the rear suspension sag under the weight of the sprung portion of the bike alone (without rider's weight) to the Unloaded dimension.

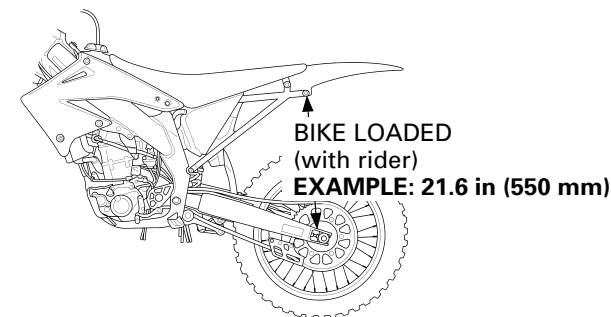

| | |
|------------------------|---------------------------|
| EXAMPLE: | |
| UNLOADED | = 23.6 in (600 mm) |
| - LOADED | = 21.6 in (550 mm) |
| SAG | = 2.0 in (50 mm) |
| (WITHOUT RIDER) | |

6. SUSPENSION ADJUSTMENT

After setting the spring preload to obtain the proper Race Sag, the suspension should sag 0.39 to 0.98 in (10 to 25 mm) from the weight of the sprung portion of the bike alone.

If after setting the spring preload (Race Sag) the bike sags more than 0.98 in (25 mm) in the rear under just its own weight, the spring is too stiff for your weight. In this case, the spring is not compressed enough, when the proper Race Sag can be attained, to allow the suspension to extend far enough on its own.

A spring that's too soft for your weight requires so much preload to achieve the proper Race Sag that it makes the rear end top-out when the rider dismounts.

If the spring rate is too soft, you have to put a lot of preload on the spring to keep the desired ride height, or Race Sag. As a result, the weight transfer is incorrect and the rear end tops-out under even light braking and on downhills.

Many people think that these soft or stiff spring indications mean the opposite. But when you take into account the effect of spring preload adjustments and the necessity of the correct Race Sag dimension, it is easier to understand.

A spring that's too firm does not allow the rear tire to hook up under acceleration and passes more of the bumps on to the rider.

Both lighter and heavier than standard springs are available for the shock and fork from your authorized Honda dealer. The need for a stiffer or softer than standard shock spring may require the installation of optional rate fork springs as well in order to maintain proper front/rear suspension balance. These and other components are listed in the Optional Parts section of this manual.

Keep in mind that a properly adjusted suspension system may bottom very slightly at least once per lap at full racing speed. This knowledge, combined with these adjustment guidelines and those on damping adjustment provided elsewhere in this manual, will give you a suspension system that's adjusted as well as any factory rider's motocrosser.

REAR SUSPENSION

Shock Adjustment

The rear shock should be adjusted for the rider's weight and track conditions.

NOTE:

- If your CRF is new, put enough part-throttle break-in time (about one hour) on it to ensure that the suspension has worked in.
1. Place a workstand under the engine to raise the rear wheel off the ground.
 2. Loosen the connecting tube clamp screw and remove the rear subframe's three mounting bolts, then remove the subframe. See page 19.
 3. Check that the spring preload is adjusted to the standard length. Adjust as necessary by loosening the lock nut and turning the adjusting nut. Pin spanners should be used for turning the lock nut and adjusting nut. See page 10 for optional pin spanners.

Spring preload length (Standard spring)

Standard: 10.21 in (259.4 mm)

Min.: 9.80 in (249.0 mm)

Spring preload length (Optional spring)

Min. (Softer. 5.3 kgf/mm): 9.88 in (251 mm)

Min. (Stiffer. 5.7 kgf/mm): 9.88 in (251 mm)

Min. (Stiffer. 5.9 kgf/mm): 9.84 in (250 mm)

NOTE:

- Each complete turn of the adjusting nut changes the spring length by 1/16 in (1.5 mm).

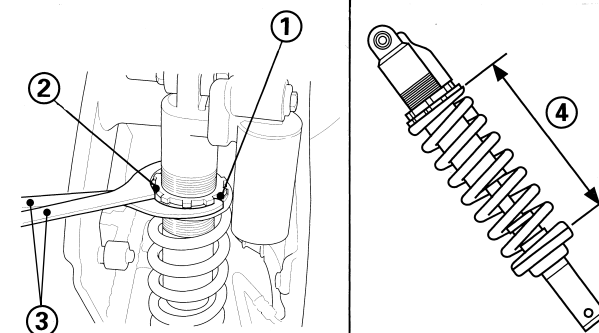

(1) ADJUSTING NUT
(2) LOCK NUT

(3) PIN SPANNERS
(4) SPRING LENGTH

Rebound Damping

The rebound damping adjuster has 17 positions or more. Turning the adjuster screw one full turn clockwise advances the adjuster four positions. To adjust the rebound damping to the standard setting, proceed as follows:

Turn the adjuster clockwise until it will no longer turn (lightly seats). This is the full hard position.

The adjuster is set in the standard position when the adjuster is turned counterclockwise 7 – 10 clicks with the punch marks on the adjuster and the shock absorber aligned.

NOTE:

- Rebound damping can be increased by turning the adjuster clockwise.

CAUTION:

- **Be sure that the rebound adjuster is firmly located in a detent, and not between positions.**

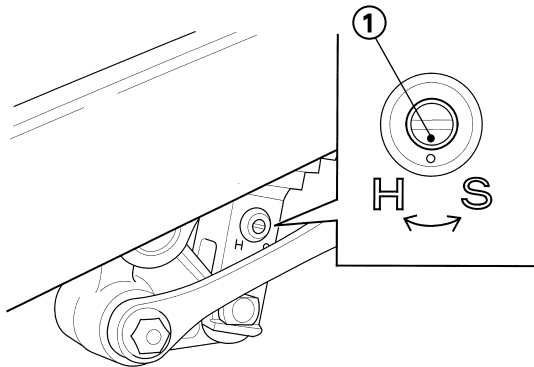

(1) REBOUND DAMPING ADJUSTER

Compression Damping

The compression damping may be adjusted in two stages with separate adjusters.

The high speed damping adjuster is effective when damping adjustment is desired for high speed operation. The low speed damping adjuster should be used when damping adjustment is desired at relatively low speeds.

The high speed damping can be adjusted by turning the hexagonal portion of the compression adjuster.

To adjust the high speed compression damping to the standard, proceed as follows:

Turn the adjuster clockwise until it will no longer turn (lightly seats). This is the full hard position.

The adjuster is set in the standard position when the adjuster is turned counterclockwise $1 \frac{7}{12}$ – $2 \frac{1}{12}$ turns and the punch marks on the adjuster and the shock absorber are aligned.

The low speed damping can be adjusted by turning the center screw of the compression adjuster.

The low speed compression adjuster has 13 positions or more.

Turning the adjuster one full turn clockwise advances the adjuster four position.

To adjust the compression damping to the standard, proceed as follows:

Turn the adjuster clockwise until it will no longer turn (lightly seats). This is the full hard position.

The adjuster is set in the standard position when the adjuster is turned counterclockwise 6 clicks.

NOTE:

- Both the high and low speed compression damping can be increased by turning the appropriate adjuster clockwise.
- Adjust the high speed compression adjuster each $\frac{1}{12}$ turns.

CAUTION:

- **Be sure the low speed compression adjuster is firmly located in a detent, and not between positions.**

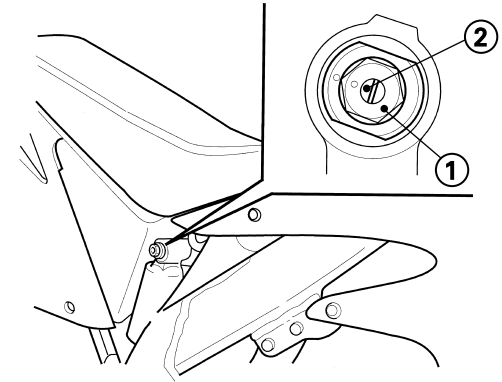

(1) HIGH SPEED DAMPING ADJUSTER
(2) LOW SPEED DAMPING ADJUSTER

6. SUSPENSION ADJUSTMENT

FRONT SUSPENSION

The fork should always be adjusted for the rider's weight and track conditions by using one or more of the following methods.

Basically, there are four adjustments you can make to the front suspension:

- Fork springs – Optional spring is available in softer and stiffer types than the standard rate. (page 10)
- Rebound damping – Turning the rebound damping screw adjusts how quickly the fork extends.
- Compression damping – Turning the compression damping screw adjusts how quickly the fork compresses.
- Oil volume – The effects of higher or lower fork oil level are only felt during the final 3.9 in (100 mm) of fork travel.

NOTE:

- Air is an unstable gas which builds up pressure as it is worked (such as in a fork). Air pressure acts as a progressive spring and affects the entire range of fork travel. This means the fork action on your CRF will get stiffer during a race. For this reason, release built-up air pressure in the fork legs between motos. Be sure the fork is fully extended with the front tire off the ground when you release the pressure.

NOTE:

- The inverted fork on your CRF features sealed damper cartridges with dual (separate air and oil) chambers to prevent aeration. The design also isolates the oil in each fork tube/slider, which may contain air bubbles and/or metal particles, from the sealed cartridge to provide more consistent damping.

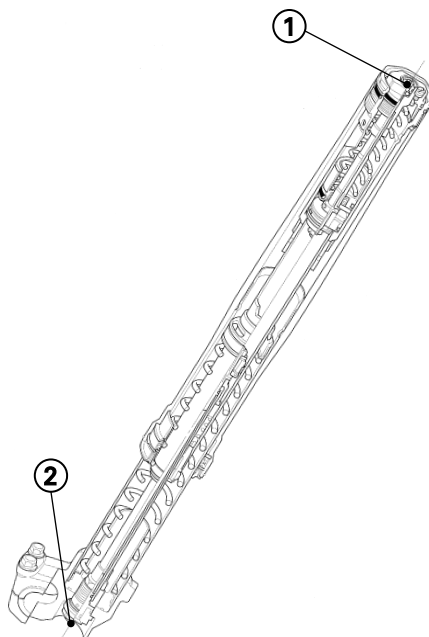

- (1) COMPRESSION DAMPING ADJUSTER
(2) REBOUND DAMPING ADJUSTER

Fork Springs

The fork springs in CRF's are about right for riders weighing between 150 and 160 lbs (less riding gear). So if you're a heavier rider, you have to go up on the oil level or get a stiffer spring. Do not use less oil than the minimum specified for each spring or there will be a loss of rebound damping control near full extension. If the fork is too hard on big bumps, turn the damping adjuster counterclockwise 1-turn and lower the oil level in increments of 0.2 oz (5 cc) in both fork legs until the desired performance is obtained. Do not, however, lower the oil level below the minimum oil level.

Minimum oil capacity:

- Standard spring: 10.9 US oz (322 cm³)**
Softer spring: 10.8 US oz (319 cm³)
Stiffer spring: 10.7 US oz (316 cm³)

NOTE:

- When adjusting oil levels, bear in mind that the air in the fork will increase in pressure while riding; therefore, the higher the oil level, the higher the eventual pressure of any air in the fork.

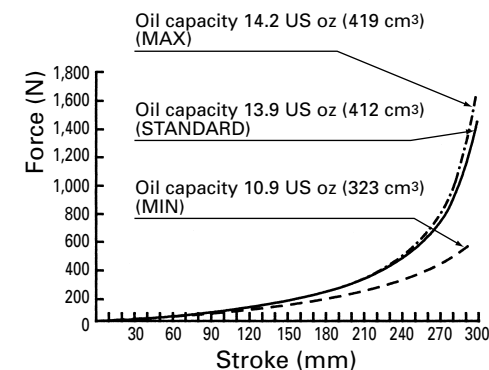

Rebound Damping Adjustment

The fork rebound damping adjuster has 16 positions or more. Turning the adjuster screw one full turn clockwise advances the adjuster four positions. To adjust the rebound damping to the standard setting, proceed as follows:

Turn the adjuster clockwise until it will no longer turn (lightly seats). This is the full hard position.

The adjuster is set in the standard position when the adjuster is turned counterclockwise 7 clicks.

Make sure that both fork legs are adjusted to the same position.

Compression Damping Adjustment

This adjustment affects how quickly the fork compresses. The fork compression damping adjuster screw has 16 positions or more. Turning the adjuster screw one full turn changes the adjuster four positions. To adjust the adjuster to the standard position, proceed as follows:

Turn the adjuster clockwise until it will no longer turn (lightly seats). This is the full hard position. The adjuster is set in the standard position when the adjuster is turned counterclockwise 11 clicks.

Make sure that both fork legs are adjusted to the same position.

NOTE:

- Both compression and rebound damping can be increased by turning the adjuster clockwise.

CAUTION:

- **Always start with full hard when adjusting damping.**
- **Do not turn the adjuster screw more than the given positions or the adjuster may be damaged.**
- **Be sure that the rebound and compression adjusters are firmly located in a detent, and not between positions.**

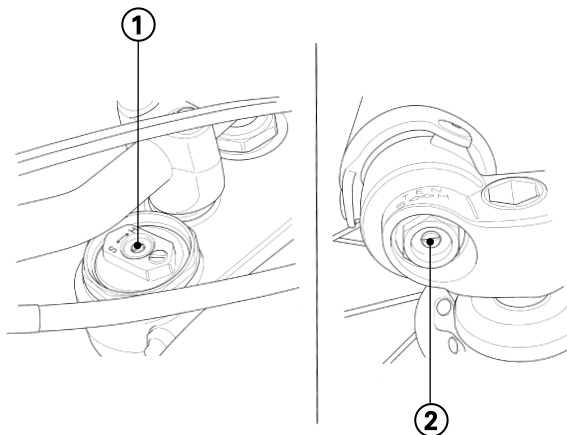

(1) COMPRESSION DAMPING ADJUSTER SCREW

(2) REBOUND DAMPING ADJUSTER SCREW

Fork Oil Change

NOTE:

- If your CRF is brand-new, put enough part-throttle break-in time (about one hour) on it to ensure that the suspension has worked in.
- For optimum performance, and extended fork life, the fork should be completely disassembled and cleaned after the first three hours of riding. See the Service Manual or your authorized Honda dealer for this service.

Place your CRF on the optional workstand or equivalent support with the front wheel off the ground. Remove the number plate bolt and number plate.

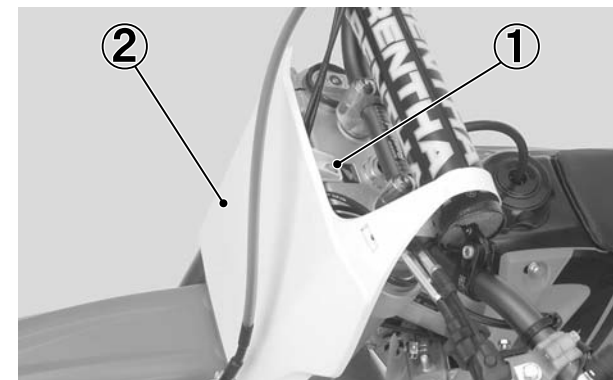

(1) NUMBER PLATE BOLT
(2) NUMBER PLATE

6. SUSPENSION ADJUSTMENT

Remove the handlebar pad.
Remove the handlebar holder nuts, washers, mounting rubbers and handlebar.

CAUTION:

- **Keep the master cylinder upright to prevent air from entering system.**



(1) HANDLEBAR HOLDER NUTS
(2) HANDLEBAR

Loosen the upper pinch bolts.
Loosen the fork dampers, but do not remove them yet.

CAUTION:

- **Do not use an adjustable wrench to loosen the fork damper: it may damage them.**
- **Loosen the upper pinch bolts before loosening the fork damper to avoid damaging the fork cap.**



(1) UPPER PINCH BOLTS (2) FORK DAMPER

Remove the disc cover by removing the two bolts.

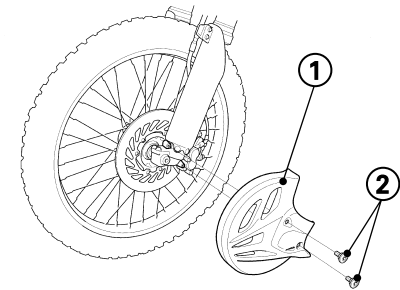

(1) DISC COVER (2) BOLTS

Remove the axle nut and loosen the axle pinch bolts on both forks.
Pull the front axle out of the wheel hub and remove the front wheel.

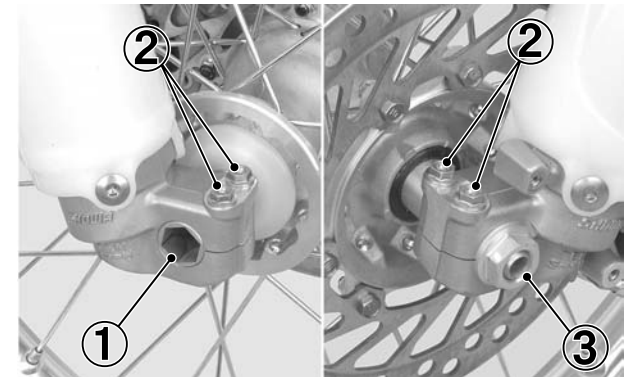

(1) FRONT AXLE (2) AXLE PINCH BOLTS
(3) AXLE NUT

Remove the fork protector and brake caliper.

CAUTION:

- Do not support the brake caliper by the brake hose.
- Do not operate the brake lever after the front wheel is removed. To do so will cause difficulty in fitting the brake disc between the brake pads.

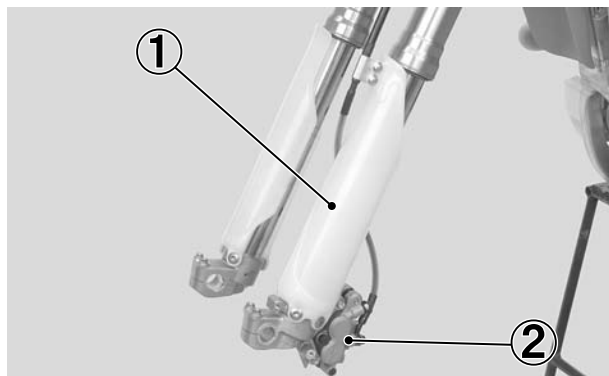

(1) FORK PROTECTOR (2) BRAKE CALIPER

Loosen the fork leg lower pinch bolts, then pull the fork legs down and out.

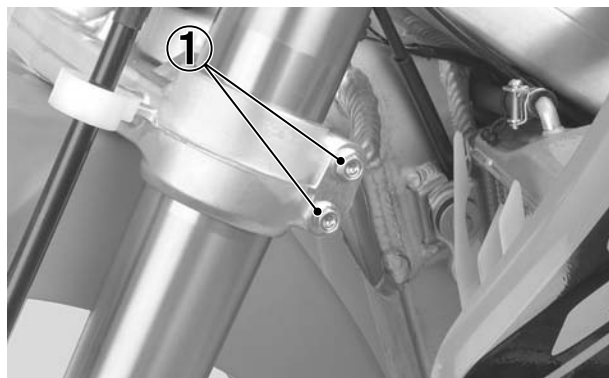

(1) LOWER PINCH BOLTS

Clean the fork assembly, especially the sliding surface of the slider and dust seal.

CAUTION:

- The outer tube can drop on the slider and damage the fork dust seal and guide bushing when the fork damper is removed. To avoid damage hold both the outer tube and slider when removing the fork cap.

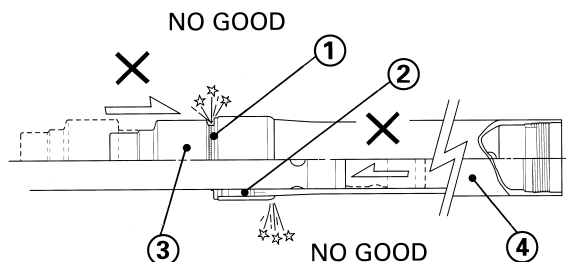

(1) DUST SEAL (2) GUIDE BUSHING
(3) SLIDER (4) OUTER TUBE

Record the rebound damping adjuster position and turn the adjuster counterclockwise until it stops.

Hold the outer tube, then remove the fork damper from the outer tube using a special tool. Gently slide the outer tube down onto the lower end of the slider.

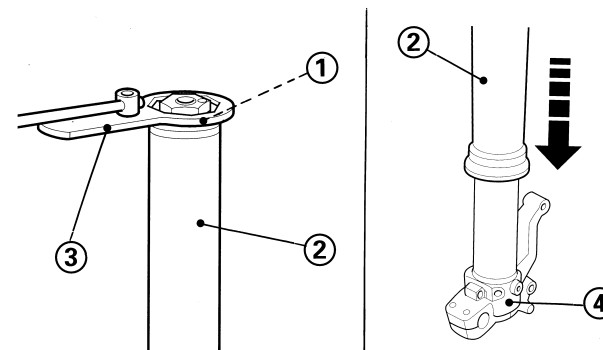

(1) FORK DAMPER (2) OUTER TUBE
(3) LOCK NUT WRENCH (4) SLIDER, LOWER END

6. SUSPENSION ADJUSTMENT

Pour the fork oil from the outer tube.
 Pour the fork oil from the oil hole of the fork damper.

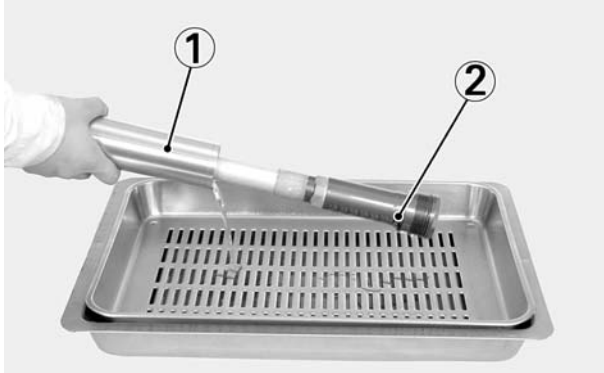

(1) OUTER TUBE

(2) OIL HOLE

Drain the fork oil by turning the outer tube upside down.
 (About 12 cc of fork oil will be left in the outer tube when it is left inverted for about 20 minutes at 20 °C/ 68°F.)

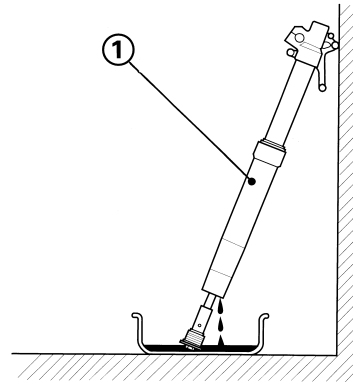

(1) OUTER TUBE

Amount of fork oil left in the fork
 (within damper and spring)

unit: cc

| minute °C/°F | 5 | 10 | 20 | 35 | 55 | 85 | 145 |
|-----------------|------|------|------|------|------|------|------|
| 30/86 | 27 | 15.3 | 10.6 | 9.4 | 8.3 | 7.9 | 7.9 |
| 20/68 | 29.4 | 16.5 | 11.8 | 10.6 | 9.4 | 8.2 | 8.2 |
| 10/50 | 28.2 | 21.2 | 16.5 | 15.3 | 12.9 | 11.8 | 11.8 |
| 0/32 | 30.6 | 22.4 | 18.8 | 16.5 | 16.5 | 15.3 | 14.1 |

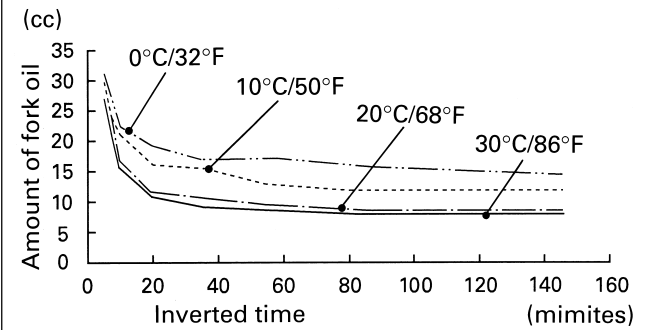

Pour the recommended fork oil into the outer tube.

RECOMMENDED OIL: Pro Honda HP Fork Oil 5 W or equivalent.

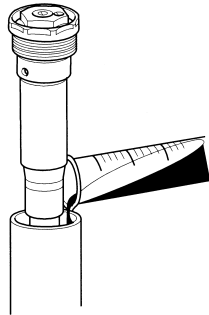

Fork Oil Capacity:

Standard (0.47 kgf/mm) Fork Spring

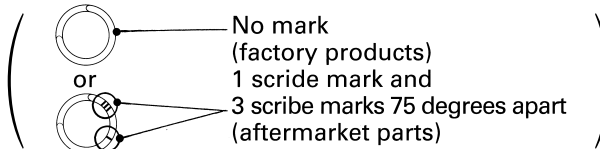

| | | |
|-----------------------|-----------------------------------|--|
| Standard oil capacity | 14.1 US oz (416 cm ³) | |
| Maximum oil capacity | 14.2 US oz (420 cm ³) | Slightly stiffer as it nears full compression. |
| Minimum oil capacity | 10.9 US oz (322 cm ³) | Slightly stiffer as it nears full compression. |

Optional Softer (0.45 kgf/mm) Fork Spring

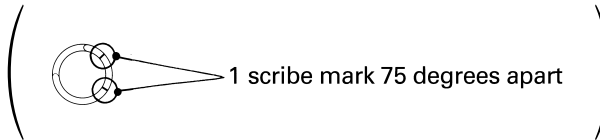

| | | |
|-----------------------|-----------------------------------|--|
| Standard oil capacity | 14.0 US oz (413 cm ³) | |
| Maximum oil capacity | 14.1 US oz (417 cm ³) | Slightly stiffer as it nears full compression. |
| Minimum oil capacity | 10.8 US oz (319 cm ³) | Slightly stiffer as it nears full compression. |

Optional Stiffer (0.49 kgf/mm) Fork Spring

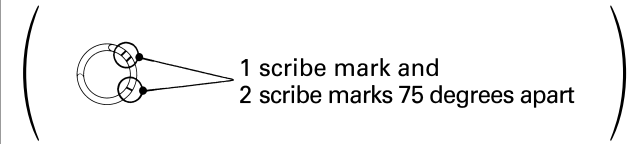

| | | |
|-----------------------|-----------------------------------|--|
| Standard oil capacity | 13.9 US oz (410 cm ³) | |
| Maximum oil capacity | 14.0 US oz (415 cm ³) | Slightly stiffer as it nears full compression. |
| Minimum oil capacity | 10.8 US oz (316 cm ³) | Slightly stiffer as it nears full compression. |

NOTE:

- Be sure the oil capacity is the same in both fork legs.

6. SUSPENSION ADJUSTMENT

Check that the O-ring on the fork damper is in good condition. Apply the recommended fork oil to the O-ring.

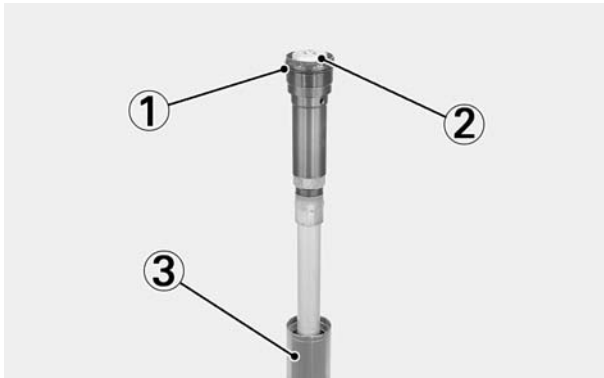

- (1) O-RING
- (2) FORK DAMPER
- (3) OUTER TUBE

Temporarily thread the fork damper into the outer tube. Insert both fork legs into the fork clamps. Align the groove in the outer tube with the top surface of the upper fork clamp.

If installing the optional 20 inch wheel, align the top of the outer tube (not the top of the fork cap) with the top surface of the upper fork clamp.

Temporarily tighten the fork lower pinch bolts and then tighten the fork damper to the specified torque using a special tool.

TORQUE: 25 lbf·ft (34 N·m, 3.5 kgf·m)

For ease of releasing air pressure after the forks are installed, loosen the lower pinch bolts and position the outer tubes so that the pressure release screws are in front of the rebound damping adjusters.

Tighten the fork lower pinch bolts.

TORQUE: 15 lbf·ft (21 N·m, 2.1 kgf·m)

Tighten the fork upper pinch bolts.

TORQUE: 17 lbf·ft (23 N·m, 2.3 kgf·m)

CAUTION:

- **Over-tightening the pinch bolts can deform the outer tubes. Deformed outer tubes must be replaced.**

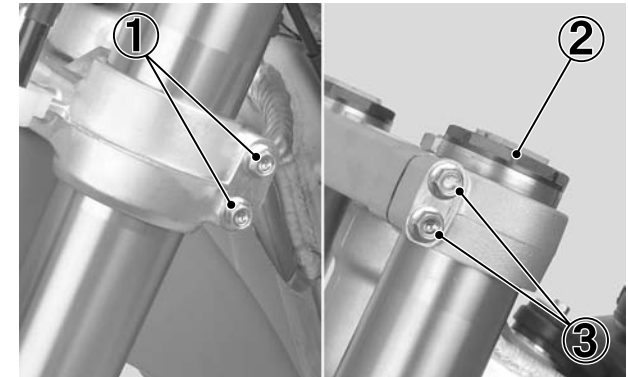

- (1) LOWER PINCH BOLTS
- (3) UPPER PINCH BOLTS

- (2) FORK DAMPER

Clean the threads of the fork protector bolts and axle holder thoroughly.
Apply locking agent to the bolt threads.
Install the fork protector and tighten the bolts.

TORQUE: 5.1 lbf·ft (6.9 N·m, 0.7 kgf·m)

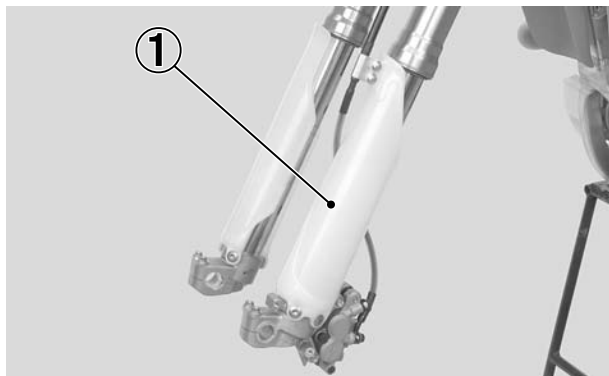

(1) FORK PROTECTOR

Clean the surfaces where the axle and axle clamps contact each other.
Install the left and right side collars into the wheel hub.
Insert the axle through the wheel hub from the right side. Make sure the axle is seated firmly onto the left fork leg clamp inner surface. Tighten the axle nut.

TORQUE: 65 lbf·ft (88 N·m, 9.0 kgf·m)

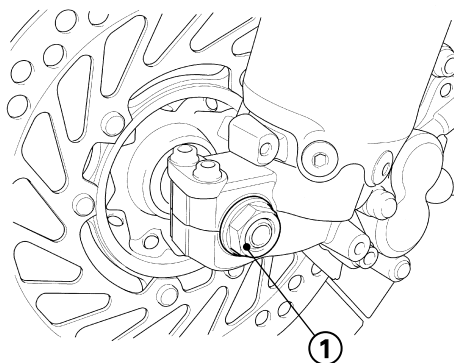

(1) AXLE NUT

Align the brake caliper and hose with the left fork leg, making sure that the brake hose is not twisted.

Clean the threads of the caliper mounting bolts and brake caliper thoroughly.
Apply locking agent to the bolt threads.
Install the brake caliper on the slider and tighten the caliper mounting bolts.

TORQUE: 22 lbf·ft (30 N·m, 3.1 kgf·m)

▲WARNING

- *An improperly routed brake hose may rupture and cause a loss of braking efficiency. Route the hose carefully*

CAUTION:

- *Fit the brake caliper over the disc, taking care not to damage the brake pads.*

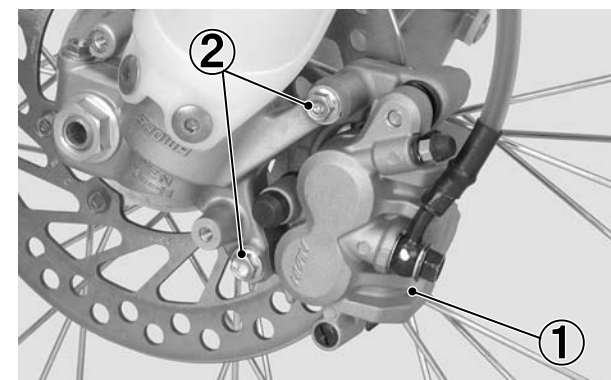

(1) CALIPER

(2) CALIPER MOUNTING BOLTS

6. SUSPENSION ADJUSTMENT

Install the handlebar, mounting rubbers, washers and handlebar holder nuts and tighten the handlebar holder nuts.

TORQUE: 33 lbf·ft (44 N·m, 4.5 kgf·m)

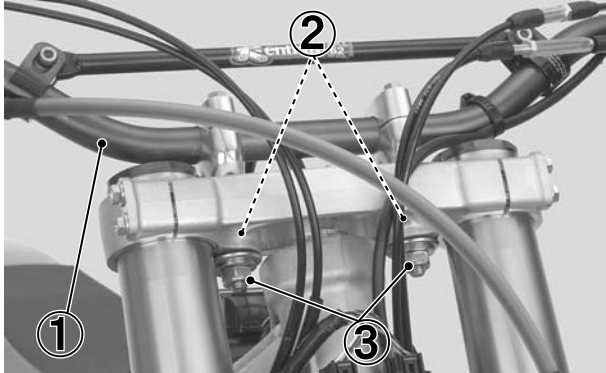

(1) HANDLEBAR (2) MOUNTING RUBBERS
(3) WASHERS/HANDLEBAR HOLDER NUTS

Install the number plate by aligning its hole with the tab on the steering stem.



(1) NUMBER PLATE (2) TAB

Install and tighten the number plate bolt. Install the handlebar pad.

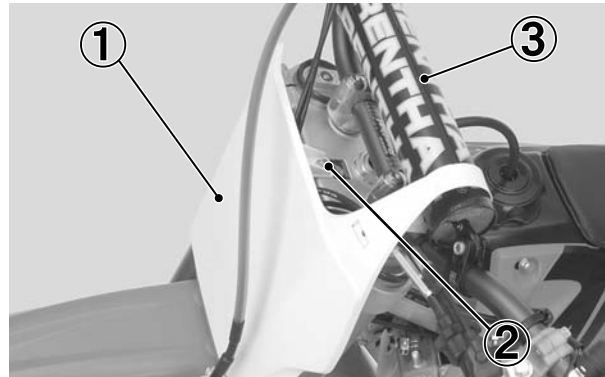

(1) NUMBER PLATE
(2) NUMBER PLATE BOLT
(3) HANDLE BAR PAD

With the front brake applied, pump the fork up and down several times to seat the axle and check front brake operation.

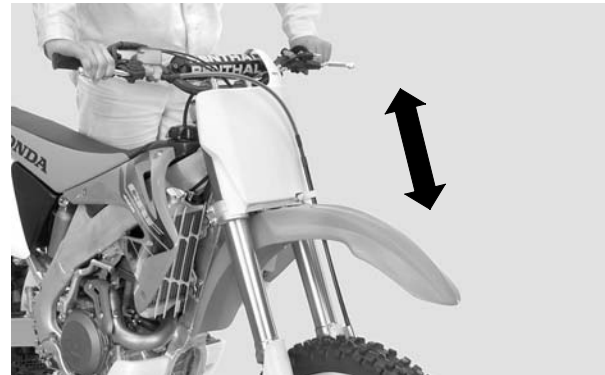

Tighten the left fork pinch bolts alternately first. While keeping the forks parallel, alternately tighten the right fork pinch bolts.

TORQUE: 14 lbf·ft (20 N·m, 2.0 kgf·m)

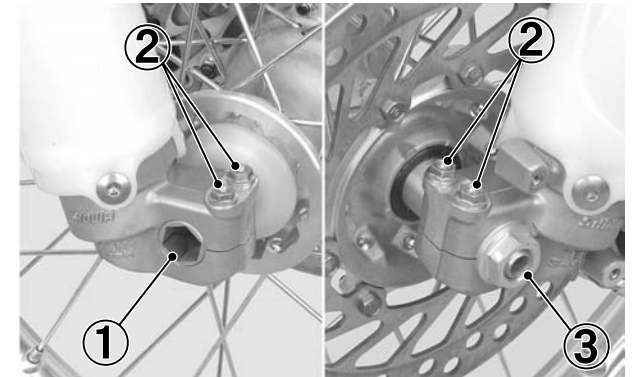

(1) FRONT AXLE
(3) AXLE NUT

(2) AXLE PINCH BOLTS

CAUTION:

- **When torquing the axle pinch bolts, be sure the axle is seated firmly onto the left fork leg clamp inner surface.**

Clean the threads of the disk cover bolts and axle holder thoroughly.

Apply locking agent to the bolt threads. Install the disc cover and tighten the bolts.

TORQUE: 9 lbf·ft (13 N·m, 1.3 kgf·m)

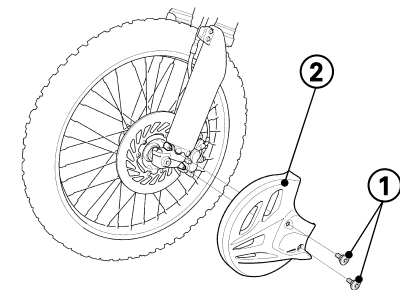

(1) BOLTS

(2) DISC COVER

Turn the rebound damping adjusters back to their original settings.

Fork Disassembly

Remove the fork as described in Fork Oil Change (pages 75 – 77).

Clean the fork assembly, especially the sliding surface of the slider and bottom of the slider around the center bolt before disassembling the fork.

CAUTION:

- **Be careful not to scratch the slider and not to damage the dust seal.**

Measure the length between the axle holder and outer tube and record it before disassembling the fork.

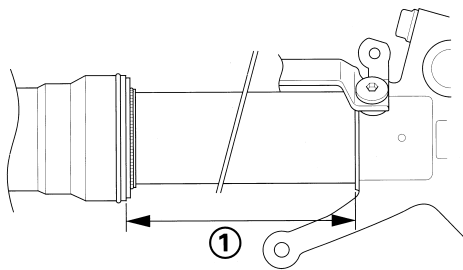

(1) LENGTH

Hold the outer tube, remove the fork damper from the outer tube using a special tool and slide the outer tube down to the dust seal on the axle holder.

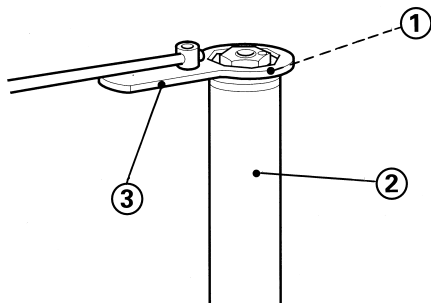

(1) FORK DAMPER
(2) OUTER TUBE

(3) LOCK NUT WRENCH

Pour the fork oil from the outer tube.
Pour the fork oil from the oil hole of the fork damper.

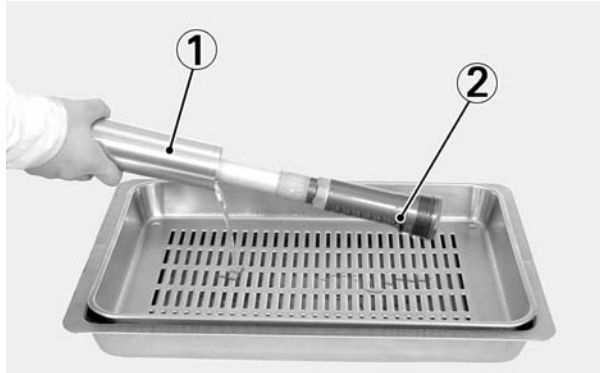

(1) OUTER TUBE (2) OIL HOLE

Temporarily install the fork damper to the outer tube.

Set the lower end (axle holder) of the slider in a vise with a piece of wood or soft jaws to avoid damage.

CAUTION:

- **Do not overtighten the axle holder.**

Loosen the center bolt.

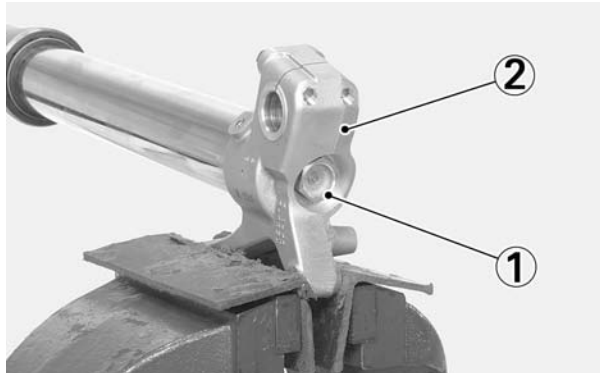

(1) CENTER BOLT (2) AXLE HOLDER

Push out the fork center bolt from the axle holder of the slider by pushing the fork damper.

Apply pressure to the fork damper and insert a special tool or mechanic's stopper tool (see below) between the axle holder and lock nut.

Hold the lock nut and remove the fork center bolt from the fork damper.

CAUTION:

- **Do not remove the lock nut from the fork damper piston rod. If the lock nut is removed, the piston rod will fall in the fork damper and you can not re-assemble the fork damper.**

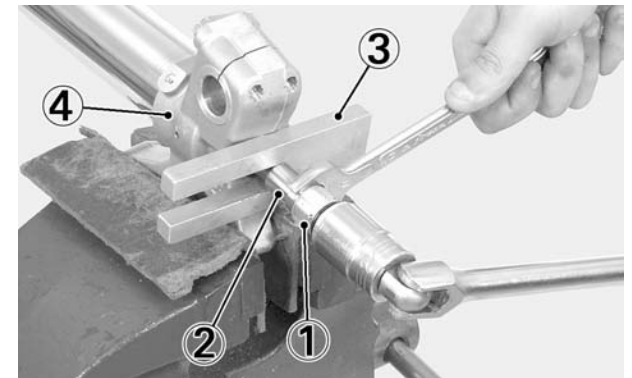

(1) CENTER BOLT (2) LOCK NUT
(3) STOPPER TOOL (4) AXLE HOLDER

Make the mechanic's stopper tool out of a thin piece of steel (1.0 mm thick) as shown if you do not have the special tool.

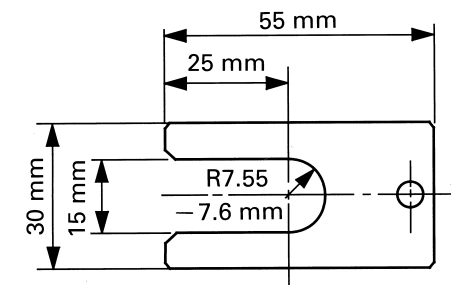

6. SUSPENSION ADJUSTMENT

Remove the push rod from the fork damper.

Remove the special tool or mechanic's stopper tool between the axle holder and lock nut while applying pressure to the fork cap.

CAUTION:

- **Be careful not to damage the lock nut and fork center bolt hole.**

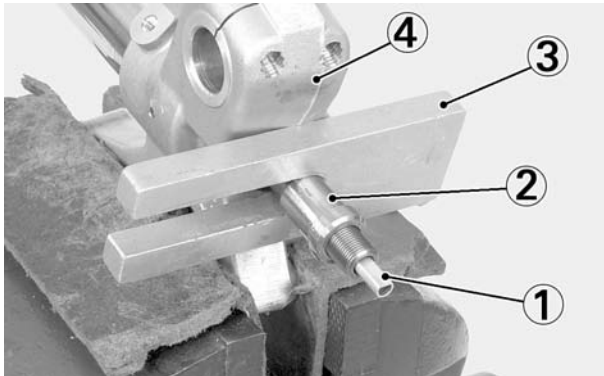

(1) PUSH ROD (3) TOOL
(2) LOCK NUT (4) AXLE HOLDER

Remove the fork damper from the outer tube and fork damper from the fork.

Remove the fork from the vise.

Remove the fork spring from the fork.

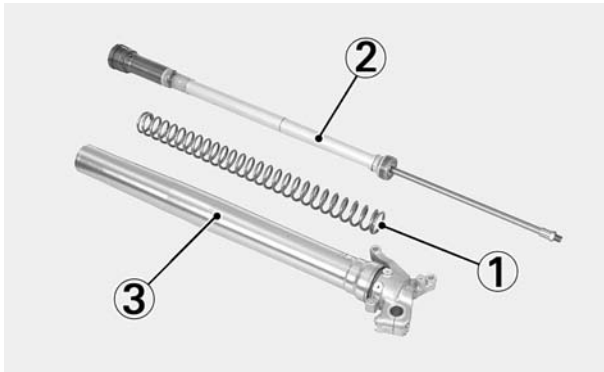

(1) SPRING
(2) FORK DAMPER ASSEMBLY
(3) FORK ASSEMBLY

Damper Oil Change

CAUTION:

- **Check the lock nut installation. If lock nut is removed, piston rod falls in the fork damper and you can not reassemble the fork damper.**

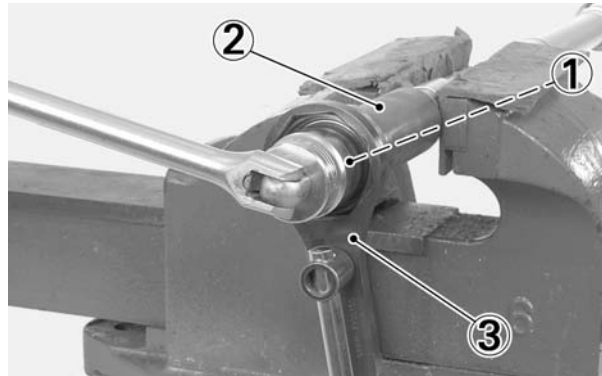

(1) FORK CAP
(2) FORK DAMPER
(3) LOCK NUT WRENCH

Loosen the fork cap by turning the fork damper using the special tool.

Remove the fork cap from the fork damper.

NOTE :

- Be careful not to damage the fork cap bushing.
- Do not disassemble the fork cap assembly. Replace the fork cap as an assembly if it is damaged.

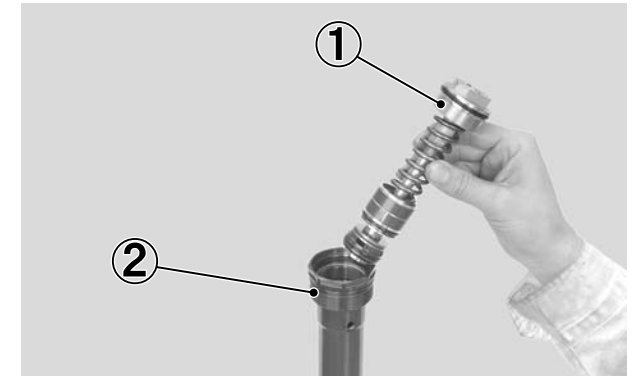

(1) FORK CAP ASSEMBLY (2) FORK DAMPER

Empty the fork oil from the fork damper by pumping the damper rod several times.

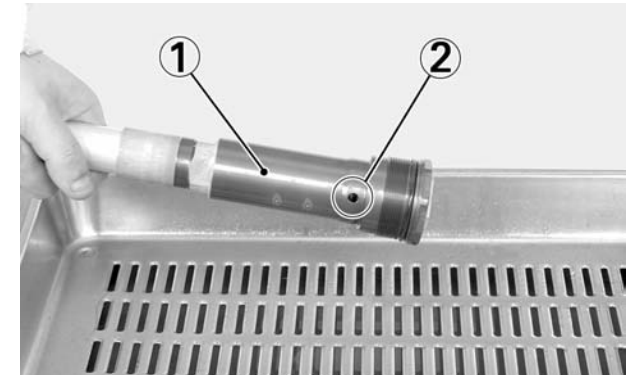

(1) FORK DAMPER (2) OIL HOLE

Clean the fork cap and fork damper threads.

Extend the fork damper piston rod to maximum.
Pour the recommended fork oil into the fork damper.

RECOMMENDED OIL: Pro Honda HP Fork Oil 5 W or equivalent
Recommended Amount: 6.6 US oz (195 cc, 6.9 Imp oz)

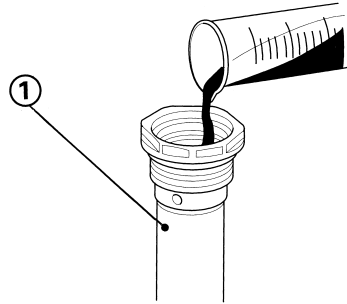

(1) FORK DAMPER

Pump the fork damper piston rod slowly several times to bleed the air from the fork damper.

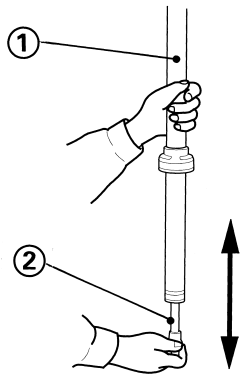

(1) FORK DAMPER
(2) PISTON ROD

Extend the fork damper piston rod to maximum. Adjust the oil level of the fork damper as shown.

OIL LEVEL: 1.65 – 1.85 in (42 – 47 mm)

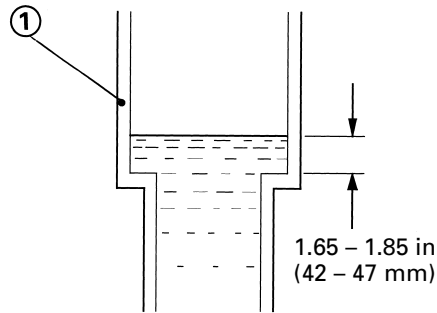

(1) FORK DAMPER

Apply fork oil to the bushing and new O-ring on the fork cap assembly.

Extend the fork damper piston rod to maximum, holding it, install the fork cap assembly to the fork damper.

NOTE:

- Be careful not to damage the fork cap bushing.
- If it is difficult to install the fork cap assembly, the fork damper oil level might be higher than standard oil level. Inspect the fork damper oil level again,

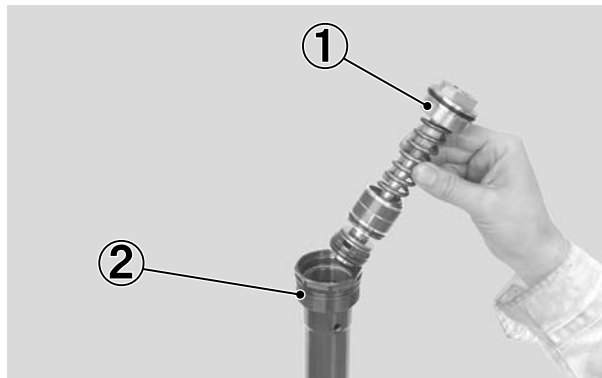

(1) FORK CAP
(2) FORK DAMPER

Tighten the fork cap while holding the cut out of the fork damper using the special tool.

TORQUE: 22 lbf·ft (29 N·m, 3.0 kgf·m)

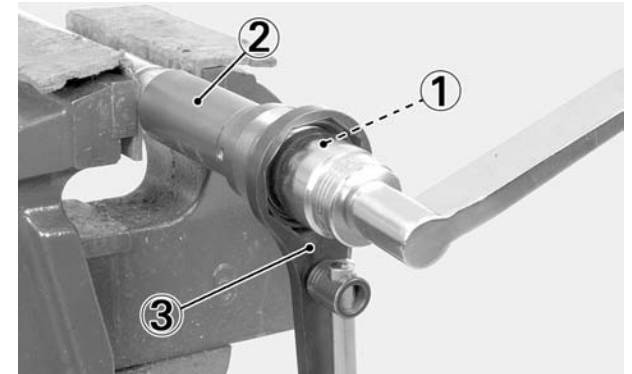

(1) FORK CAP (2) FORK DAMPER
(3) LOCK NUT WRENCH

Hold the fork damper in an upright position and pump the fork piston rod to 3.9 in (100 mm) slowly several times.

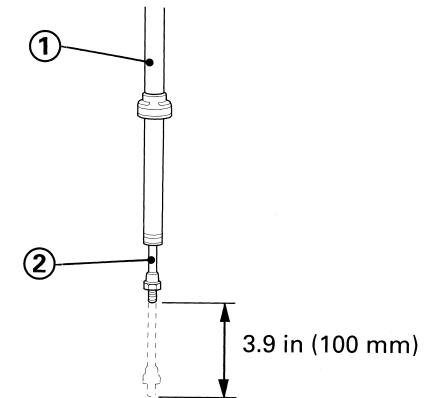

(1) FORK DAMPER
(2) PISTON ROD

6. SUSPENSION ADJUSTMENT

Screw in the lock nut to the fork damper piston rod fully.

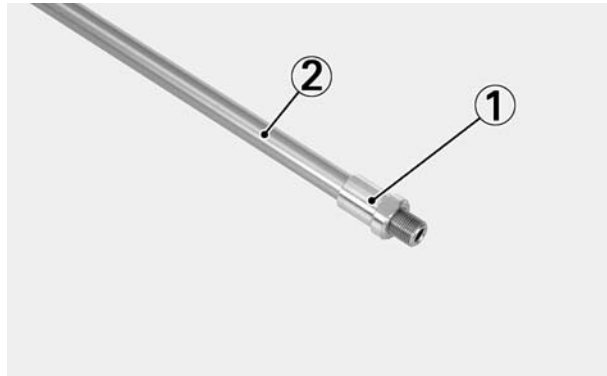

(1) LOCK NUT (2) PISTON ROD

NOTE:

- Turn the rebound adjuster and compression adjuster counterclockwise to the softest position.
- Check the fork damper piston rod sliding surface for damage.
- Apply fork oil to the fork damper piston rod sliding surface

Cover the fork piston rod end with soft jaws to prevent fork damage.

CAUTION:

- **Be careful not to bend or damage the fork damper piston rod when the piston rod is stroked.**

Blow the extra oil off to the fork damper spring chamber by pumping the fork damper piston rod to full stroke.

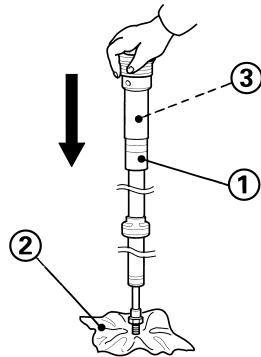

(1) FORK DAMPER (2) SOFT JAWS
(3) SPRING CHAMBER

Drain the extra oil from the fork damper spring chamber oil hole.

NOTE:

- By doing this procedure, about 17 cm³ of fork fluid will be drained from the damper spring chamber through the oil hole and cause 178 cm³ of fork fluid to be left in the chamber.

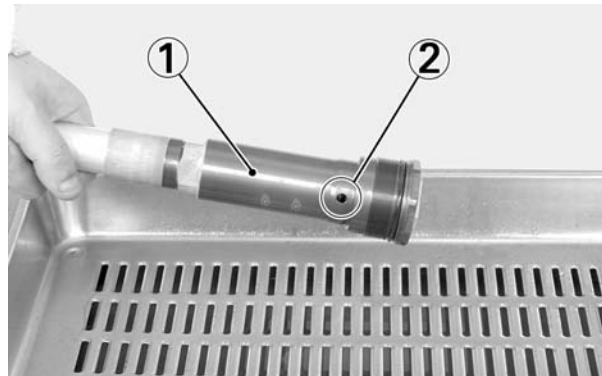

(1) SPRING CHAMBER
(2) OIL HOLE

Blow out the oil from the fork damper spring chamber using compressed air to the oil hole.

Wipe the oil completely off the fork damper.

If you can not use compressed air, remove the pressure release screw on the fork cap. Hold the fork damper up side down for 10 minutes and drain the oil from the fork damper spring chamber.

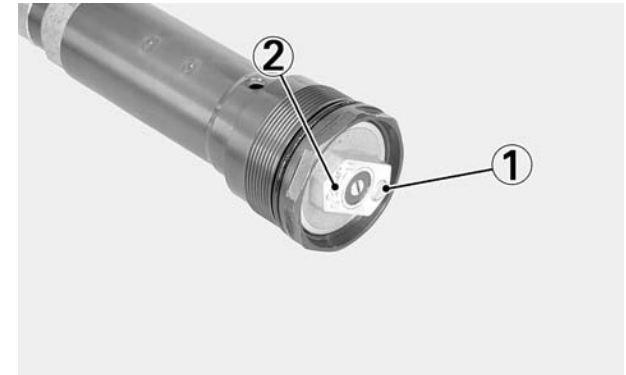

(1) PRESSURE RELEASE SCREW
(2) FORK CAP

Fork Assembly

Drain the fork oil from the outer tube/slider by placing it upside down.

(About 7 cc of fork oil will be left in the outer tube/slider when it is left inverted for about 20 minutes at 20°C)

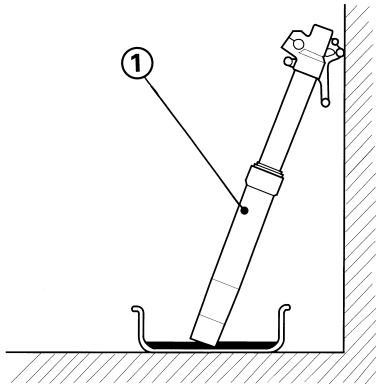

(1) OUTER TUBE/SLIDER

Amount of fork oil left in the fork (without damper and spring)

unit: cc

| minute | 5 | 10 | 20 | 35 | 55 | 85 | 145 |
|--------|------|------|-----|-----|-----|-----|-----|
| °C/°F | | | | | | | |
| 30/86 | 7.1 | 5.9 | 4.7 | 4.2 | 3.5 | 3.5 | 3.5 |
| 20/68 | 10.6 | 8.2 | 7.1 | 5.9 | 5.6 | 4.7 | 4.7 |
| 10/50 | 11.8 | 8.3 | 7.2 | 6.2 | 5.8 | 4.9 | 4.8 |
| 0/32 | 12.9 | 10.6 | 9.4 | 8.2 | 7.9 | 7.1 | 5.9 |

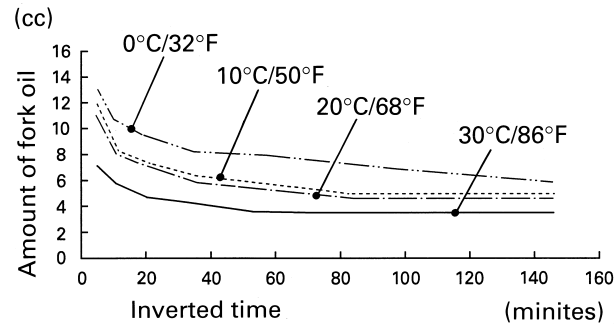

Tighten the lock nut fully and measure the thread length as shown.

STANDARD: 0.43 – 0.51 in (11 – 13 mm)

Wipe the oil completely off the fork damper.

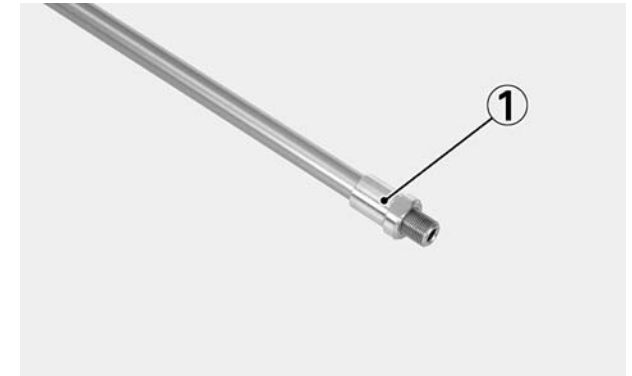

(1) LOCK NUT

Wipe the oil completely off the fork spring.

Install the fork spring.

Install the fork damper to the outer tube/slider.

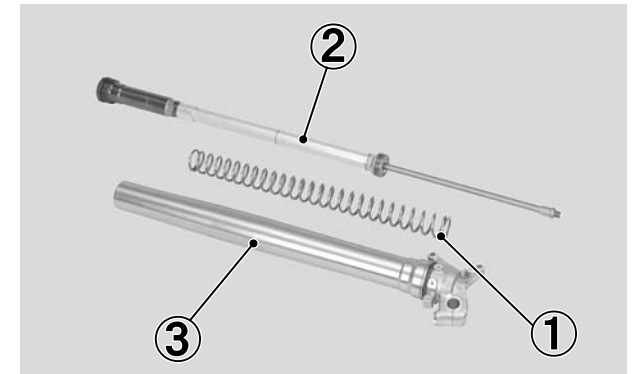

(1) SPRING
(2) FORK DAMPER ASSEMBLY
(3) OUTER TUBE/SLIDER

6. SUSPENSION ADJUSTMENT

Set the lower end (axle holder) of the slider in a vise with a piece of wood or soft jaws to avoid to damage.

CAUTION:

- **Do not overtighten the axle holder.**

Temporarily install the fork damper to the fork. Push out the fork damper piston rod from the axle holder of the slider by pushing the fork damper. Apply pressure to the fork damper and insert the special tool or mechanic's stopper tool between the axle holder and lock nut. Measure the thread length again.

STANDARD: 0.43 – 0.51 in (11 – 13 mm)

Install the push rod into the piston rod until it stops.

NOTE :

- Check the push rod installation by turning the push rod right and left.

Install a new O-ring to the center bolt.

Install the fork center bolt to the fork damper piston rod aligning the center bolt adjusting rod to the push rod. Tighten the center bolt fully by hand.

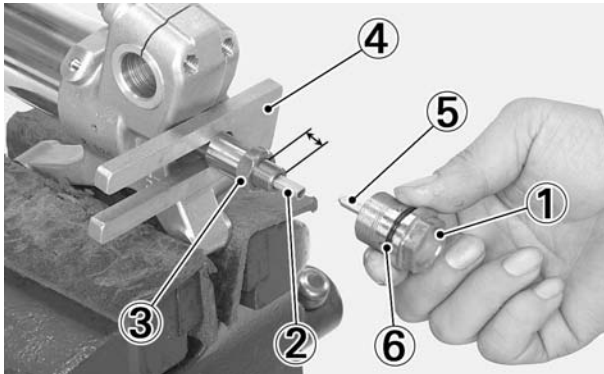

- | | |
|-----------------|-------------------|
| (1) CENTER BOLT | (4) STOPPER TOOL |
| (2) PUSH ROD | (5) ADJUSTING ROD |
| (3) LOCK NUT | (6) O-RING |

Measure the length of the lock nut and center bolt clearance.

STANDARD: 0.06 – 0.08 in (1.5 – 2.0 mm)

If the clearance is out of specification, check the lock nut and center bolt installation.

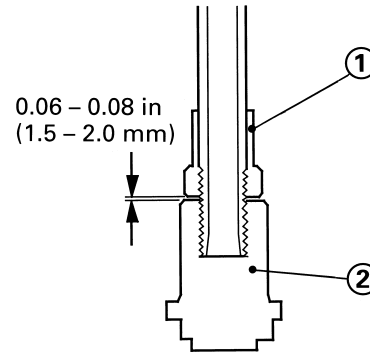

- | |
|-----------------|
| (1) LOCK NUT |
| (2) CENTER BOLT |

Tighten the lock nut to the center bolt closely by hand. Tighten the lock nut to the specified torque.

TORQUE: 16 lbf·ft (22 N·m, 2.2 kgf·m)

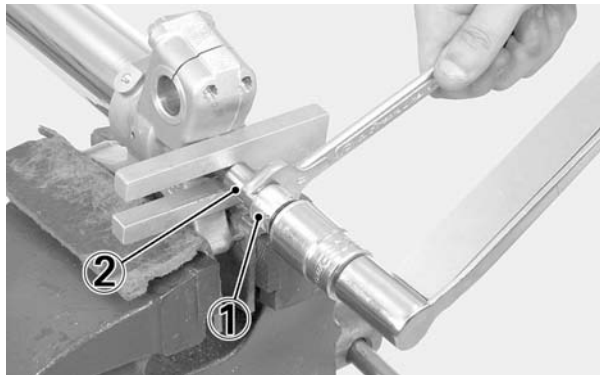

- | |
|-----------------|
| (1) CENTER BOLT |
| (2) LOCK NUT |

Apply fork oil to the center bolt O-ring. Remove the special tool or mechanic's stopper tool while applying pressure to the fork damper.

Install the center bolt to the axle holder and tighten it to the specified torque.

TORQUE: 51 lbf·ft (69 N·m, 7.0 kgf·m)



- | |
|-----------------|
| (1) CENTER BOLT |
|-----------------|

Measure the length between the axle holder and outer tube.

STANDARD: 317 ± 2 mm

Compare the length at assembly and at disassembly. They should be the same length.

If the length at assembly is longer than at disassembly, check the center bolt and lock nut installation.

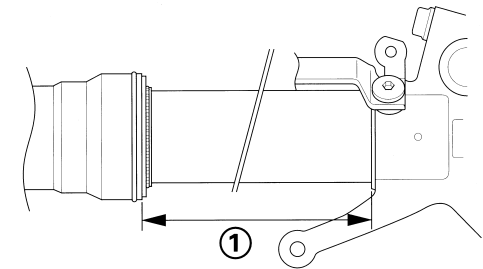

- | |
|---------------------|
| (1) STANDARD LENGTH |
|---------------------|

Pour the recommended fork oil into the fork.

RECOMMENDED OIL: Pro Honda HP Fork Oil 5 W or equivalent.

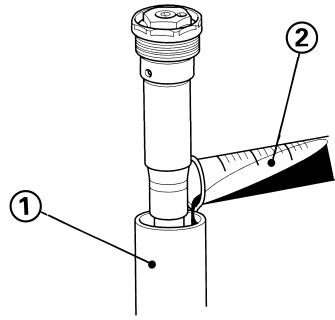

(1) FORK

(2) FORK OIL

Fork Oil Capacity:

Standard (0.47 kgf/mm) Fork Spring

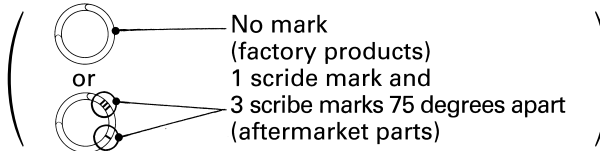

| | | |
|-----------------------|-----------------------------------|--|
| Standard oil capacity | 13.9 US oz (412 cm ³) | |
| Maximum oil capacity | 14.2 US oz (419 cm ³) | Slightly stiffer as it nears full compression. |
| Minimum oil capacity | 10.9 US oz (323 cm ³) | Slightly softer as it nears full compression. |

Optional Softer (0.45 kgf/mm) Fork Spring

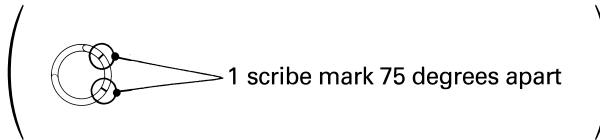

| | | |
|-----------------------|-----------------------------------|--|
| Standard oil capacity | 13.8 US oz (409 cm ³) | |
| Maximum oil capacity | 14.1 US oz (416 cm ³) | Slightly stiffer as it nears full compression. |
| Minimum oil capacity | 10.8 US oz (320 cm ³) | Slightly softer as it nears full compression. |

Optional Stiffer (0.49 kgf/mm) Fork Spring

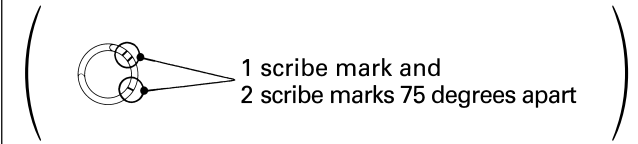

| | | |
|-----------------------|-----------------------------------|--|
| Standard oil capacity | 13.7 US oz (406 cm ³) | |
| Maximum oil capacity | 14.0 US oz (413 cm ³) | Slightly stiffer as it nears full compression. |
| Minimum oil capacity | 10.8 US oz (318 cm ³) | Slightly softer as it nears full compression. |

MOTE:

- Be sure the oil capacity is the same in both fork legs.

Install the fork damper as described in Fork oil change (page 80-82).

6. SUSPENSION ADJUSTMENT

Air Pressure Adjustment

The air pressure should be adjusted according to the altitude and outside temperature.

1. Place a workstand under the engine, so that the front wheel is off the ground.

NOTE:

- Do not adjust air pressure with the front wheel on the ground as this will give false pressure for the fork.
2. Remove the pressure release screw.
 3. Check that the O-ring is in good condition.
 4. Install the pressure release screw.

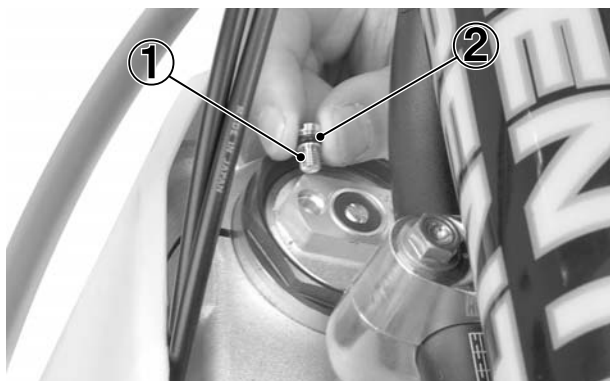

- (1) PRESSURE RELEASE SCREW
(2) O-RING

SUSPENSION ADJUSTMENTS RELATING TO SPECIFIC TRACK CONDITIONS

On soft ground, sand tracks and especially muddy tracks, you want more compression damping force front and rear. On harder ground you run less compression damping.

Sand tracks require a bit more rebound damping force as well. The bumps are usually bigger, but have more distance between them so the shock has more time to recover. And you don't want the rear end to kick up in the sand.

The spring force requirements probably won't change much between a hard track and a sand track. You may want a little bit stiffer front suspension for sand tracks to help keep the front end up and improve straight-line stability.

In a muddy race, you want a stiffer spring front and rear because your CRF becomes much heavier with the accumulation of mud.

If you don't compensate for the additional weight of the mud that collects during the race, then your CRF will be undersprung and handling will deteriorate. The suspension will be compressed too far most of the time and the bike won't hook up very well.

If it is a fast, hard track with no large jumps, you can probably run the same spring as normal, but run softer damping both ways-compression and rebound. If you run softer rebound damping, the wheel will follow the rough ground and small bumps much better, and you will hook up better. With a lot of rebound damping, the wheel returns very slowly and doesn't contact the ground quickly enough after each bump. The result is a loss of traction and slower lap times.

SUSPENSION ADJUSTMENT GUIDELINES

Follow the procedures described below to accurately adjust your CRF using the methods described on pages 72 – 89. Remember to make all adjustments in one-click increments. Test ride after each adjustment.

Fork Adjustment

Adjustments for Type of Track

| | |
|---------------------|--|
| Hard-surfaced track | Begin with the standard setting. If the suspension is too stiff/soft, adjust according to the chart below. |
| Sand track | Adjust to a stiffer position. Example: – Turn the compression damping adjuster to a stiffer position. – Install the optional stiff spring. (Adjust compression damping to a softer position and rebound damping to harder position at this time. |
| Mud track | Adjust to a stiffer position because mud build-up increases your CRF's weight Example: – Turn the compression damping adjuster to a stiffer setting. – Install the optional stiff spring. |

Adjustments for Too Soft/Stiff Damping

| | Sympton | Action |
|-----------------|---|---|
| Soft suspension | Initial travel too soft: <ul style="list-style-type: none"> • Steering is too quick • Front end darts while cornering or riding in a straight line. | <ul style="list-style-type: none"> – Test stiffer compression damping adjustments in one-click increments. – Test stiffer rebound damping adjustments in one-click increments. |
| | Middle travel too soft: <ul style="list-style-type: none"> • Front end dives when cornering. | <p>If suspension isn't stiff in initial travel:</p> <ul style="list-style-type: none"> – Test stiffer compression damping adjustments in one-click increments. <p>If initial travel becomes stiff because of the above adjustment:</p> <ul style="list-style-type: none"> – Reduse the rebound damping in one-click increments. – Test softer compression damping adjustments in one-click increments. <p>If that doesn't solve the problem, install the optional stiff spring.</p> |
| | Final travel too soft: <ul style="list-style-type: none"> • Bottoms on landings. • Bottoms on large bumps, especialy downhill bumps. | <p>If intial and middle travel are not stiff:</p> <ul style="list-style-type: none"> – Test stiffer compression damping adjustments in one-click increments. <p>If initial and middle travel is stiff:</p> <ul style="list-style-type: none"> – Install the optional stiff spring <p>If initial travel is stiff after installing the optional stiff spring:</p> <ul style="list-style-type: none"> – Test softer compression damping adjustments in one-click increments. <p>If initial travel is still soft after installing the optional stiff spring:</p> <ul style="list-style-type: none"> – Test stiffener compression damping adjustments in one-click increments. <p>If final travel is still soft after installing the optional stiff spring:</p> <ul style="list-style-type: none"> – Increase the fork oil capacity in increments of 0.2 oz (5 cc). |
| | Entire travel too soft: <ul style="list-style-type: none"> • Front end shakes. • Fork bottoms over any type of terrain. | <ul style="list-style-type: none"> – Install the optional stiff spring. – Test stiffer compression damping adjustments in one-click increments. – Increase rebound damping in one-click increments. |

6. SUSPENSION ADJUSTMENT

| | Symptom | Action |
|------------------|---|--|
| Stiff suspension | <p>Initial travel too stiff:</p> <ul style="list-style-type: none"> • Stiff on small bumps while riding at full throttle in a straight line. • Stiff on small cornering bumps. • Front end wanders while riding at full throttle in a straight line. | <ul style="list-style-type: none"> – Test softer compression damping adjustments in one-click increments. – Reduce the rebound damping adjustments in one-click increments. – Check for dirt in the dust seals. Check the fork oil for any contamination. <p>NOTE:</p> <ul style="list-style-type: none"> • If the front end dives while cornering, reduce the rebound damping in one-click increments. If that doesn't solve the problem, install the optional stiff spring. • If the stiff spring makes the suspension too stiff over the full range of travel: test softer compression damping adjustments in one-click increments until the desired compression damping for initial travel is obtained. |
| | <p>Middle travel too stiff:</p> <ul style="list-style-type: none"> • Stiff on bumps when cornering. • Front end wanders when cornering. • Stiff suspension on bumps, especially downhill bumps. • While braking, front end dives during initial travel, then feels stiff. | <p>If initial travel isn't stiff:</p> <ul style="list-style-type: none"> – Test stiffer compression damping adjustments in one-click increments. (This should produce smooth fork action from initial to middle travel.) <p>If initial and middle travel is stiff.</p> <ul style="list-style-type: none"> – Test softer compression damping adjustments in one-click increments. – Reduce the rebound damping in one-click increments. |
| | <p>Final travel too stiff:</p> <ul style="list-style-type: none"> • Doesn't bottom on landings, but feels stiff. • Stiff on large bumps, especially downhill bumps. • Stiff on large bumps when cornering. | <p>If initial and middle travel aren't stiff:</p> <ul style="list-style-type: none"> – Test stiffer compression damping adjustments in one-click increments. (This should produce smooth fork action from initial to middle travel.) <p>If final travel is still stiff after the above adjustment, or...</p> <p>If initial and middle travel become stiff.</p> <ul style="list-style-type: none"> – Install the optional stiff spring. – Test softer compression damping adjustments in one-click increments. <p>If the entire travel feels stiff after the above adjustment:</p> <ul style="list-style-type: none"> – Test softer compression damping adjustments in one-click increments until the desired initial travel compression damping is obtained. – Lower the oil capacity by 0.2 oz (5 cc). |
| | <p>Entire travel too stiff:</p> <ul style="list-style-type: none"> • Stiff suspension on any type of terrain. | <ul style="list-style-type: none"> – Test softer compression damping adjustments in one-click increments. – Reduce the rebound damping in one-click increments. – Lower the oil capacity by 0.2 oz (5 cc). |

Rear Suspension Adjustment Adjustments for Type of Track

| | |
|---------------------|--|
| Hard-Surfaced track | Begin with the standard setting. If the suspension is too stiff/soft, adjust according to the chart below. |
| Sand track | Lower the rear end (to improve front wheel stability) by increasing Race Sag (reduce spring preload). Example: – Turn both compression damping adjusters and, especially, rebound damping adjuster to a stiffer setting. – Increase standard Race Sag (+0.2 to 0.4 in/5 to 10 mm). |
| Mud track | Adjust to a stiffer position because mud build-up increases your CRF's weight Example: – Adjust the compression and rebound damping adjusters to stiffer settings. – Install the optional stiff spring. – Reduce standard Race Sag (–0.2 to 0.4 in/5 to 10 mm). |

Symptoms and Adjustment

- Always begin with the standard settings.
- Turn the low speed compression and rebound adjusters in one-click increments, and the high speed compression adjuster in 1/6 turn increments at a time. Adjusting two or more clicks or turns at a time may cause you to pass over the best adjustment. Test ride after each adjustment.
- If, after setting, the suspension feels unusual, find the corresponding symptom in the table and test stiffer or softer compression and/or rebound damping adjustments until the correct settings are obtained as described.

| | Sympton | Action |
|--------------------|--|---|
| Stiff suspension | Suspension feels stiff on small bumps | 1. Test softer low speed compression adjustment. 2. If it still feels stiff, further test softer low and high speed compression adjustments simultaneously. |
| | Suspension feels stiff on large bumps | 1. Test softer high speed compression adjustment. 2. If it still feels stiff, further test softer low and high speed compression adjustments simultaneously. |
| | Entire travel too stiff | 1. Test softer high and low speed compression adjustments and rebound adjustment simultaneously. 2. If it still feels stiff, replace the spring with a softer spring (optional) and begin with the standard settings to softer settings. |
| Soft suspension | Entire travel too soft | 1. Test stiffer high and low speed compression adjustments simultaneously 2. If it still feels soft, replace the spring with a stiffer spring (optional) and begin with the standard settings to softer settings. |
| | Rear end sways | 1. Test stiffer high and low speed compression adjustments and rebound adjustment to stiffer settings simultaneously. |
| Suspension bottoms | Suspension bottoms at landing after jumping | 1. Test stiffer high speed compression adjustment. 2. If it still bottoms, test stiffer high and low speed side compression adjustments and replace the spring with a stiffer spring (optional) if necessary. |
| | Suspension bottoms after landing | 1. Test stiffer low speed compression adjustments. 2. If it still bottoms, test stiffer high and low speed compression adjustments and replace the spring with a stiffer spring (optional) if necessary. |
| | Suspension bottoms after end of continuous bumps | 1. Test softer rebound damping adjustment. 2. If it still bottoms, test stiffer high and low speed compression adjustments and softer rebound damping adjustment and replace the spring with a stiffer spring (optional) if necessary. |

7. CHASSIS ADJUSTMENTS FOR TRACK CONDITIONS

Rear End

If you have a problem with rear wheel traction, you can run a little bit more preload on the spring. Instead of running 3.9 in (100 mm) of sag, you can run 3.5 in (90 mm) so the rear of the bike will sit a little higher. This will give you more traction because of the angle of the swingarm and the location of the Center of Gravity. By contrast, you may have a problem with the steering head shaking when there is lots of front braking to do. Or, maybe the bike wants to turn too quick on you. Then you want to lower the rear of the bike. Reducing the rear spring preload will increase fork rake and trail so stability in a straight line is improved.

Fork Height/Angle

The position of the outer tubes in the clamps is not adjustable. Align the groove in the outer tube with the top surface of the upper fork clamp. If you install the optional 20 inch wheel, align the top of the fork tube with the top of the upper fork clamp.

(STANDARD POSITION)

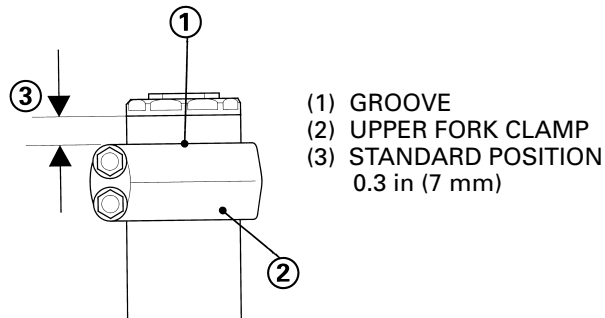

(STANDARD POSITION FOR OPTIONAL 20 in FRONT WHEEL)

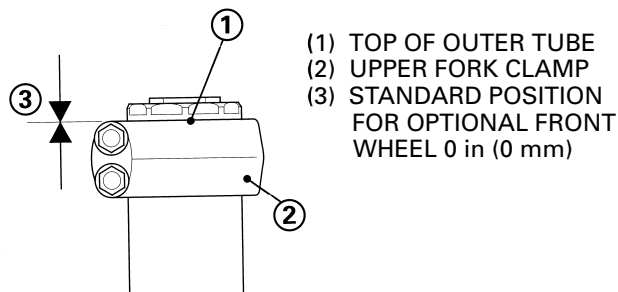

NOTE :

- Never position the top surface of the triple clamp more than 0.1 in (2 mm) below the top of the outer tube.
- Do not include the fork bolt thickness, or the chamfered edge of the tube in the height measurement.

Wheelbase

You may run the chain adjustment on the swingarm most of the way to the front or out toward the rear of the adjustment range and add or remove links as necessary. With the axle up toward the front, you will get a little bit better traction. If there are a lot of fast sections, then it may be better to run a little longer wheelbase. On a track with a lot of fast rollers, the long wheelbase works good. If it is a tight track, like a supercross track, usually a shorter wheelbase is better. Especially if the traction is poor. The shorter wheelbase also transfers more weight to the rear to help the bike hook up better and wheelie easier.

You can use these wheelbase adjustments for more or less trail as mentioned earlier. You must realize that these chassis adjustments offer subtle changes in overall handling, yet a noticeable improvement will be realized in the areas specified. If you change your wheelbase, be sure to recheck race sag and adjust, if necessary.

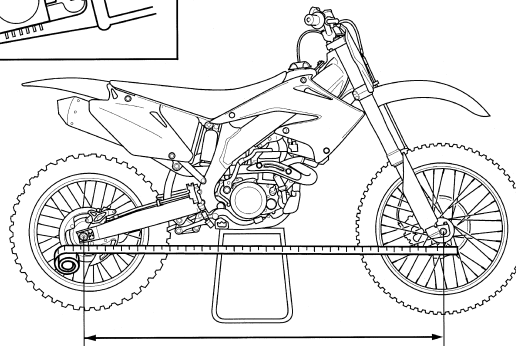
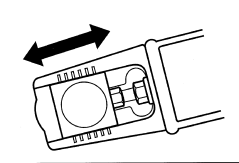

8. GEARING SELECTION

Explanation Of Effects On Power Delivery & Traction

Rather than counting on frequently unreliable, aftermarket engine modifications for improved performance, you should first try to "adjust" the power delivery of the standard engine to suit the terrain and course conditions. The easiest way to do this is to change gearing, which allows you to utilize a different portion of the engine's power range.

The portion of the power range you use can be adjusted most efficiently by changing the final drive ratio with optional sized rear sprockets. This way the power delivery can be more closely matched to the available traction, which changes from day to day, and to the type of terrain the course offers. Similarly, the number of shifts needed per lap, or for specific and critical sections, can be "adjusted" in order to reduce lap times with a simple sprocket change.

These optional driven (rear wheel) sprockets are offered in increments of two teeth less, or more, than the standard sprocket. This small difference is enough to allow you to "tune" the engine for the available traction without creating drastic changes in the top speed potential of the machine.

— Higher gearing (less rear sprocket teeth) will produce less power to the ground and allow the rear wheel to hook-up when the track is slippery (wet, sandy, loose dirt on clay base, etc.).

— Lower gearing (more rear sprocket teeth) will produce more power to the ground and allow you to utilize maximum traction conditions.

CAUTION:

- ***Unless you have the required mechanical knowhow, tools, and an authorized Honda Service Manual, sprocket changing should be done by your authorized Honda dealer.***

Some outdoor tracks may be watered heavily prior to the first race, then lightly or not at all during the day. This results in a track that is slippery during the first few races, changes from good to great then back to good traction for part of the day, then may end the day with a slick, rock-hard consistency. Ideally, your gearing should be adjusted to suit all these conditions.

- Wet and slippery or sandy conditions: use less teeth than the standard sprocket to keep the engine rpm down, and avoid unwanted wheelspin. The engine may bog in certain corners so you'll need to slip the clutch to compensate; downshifting may be too drastic a change in speed.
- Average conditions: use the standard sprocket.
- Hard (but not slippery) track conditions: use more teeth than the standard sprocket to keep the engine rpm high where the engine produces the most power. This may require an extra upshift on certain sections or perhaps you can just rev it out a bit longer.

Another example of the benefits of proper gearing for soil conditions is experienced when riding on a sand track. Of course, you want to keep the front end light so the front wheel virtually floats from the peak of one whoop to another. Generally speaking, with higher than stock overall gearing it is easier to maintain that perfect attitude of maximum rear wheel traction and a light front end because you remain in the powerband longer in each gear.

If you've ever run too low overall gearing in the sand, you've noticed that you are tapped-out very quickly and the front end feels very heavy. You don't want to be steering the bike with the front wheel much in soft sand. The taller gearing allows you to steer more efficiently with throttle control and body English. Sometimes alternate gearing can help even if track conditions are consistent throughout the day. If there are sections of the track on which you must consistently over-rev the engine (rather than losing time by upshifting), perhaps "taller" gearing (a smaller driven sprocket) will help.

Whenever you change gearing, have someone check your lap times (before and after) to get an honest appraisal of the changes. Use a stopwatch for consistency. "Seat-of-the-pants" feelings can't be trusted since eliminating wheelspin can make you feel like you're going slower, but in reality you've decreased your lap time by increasing your speed a little bit in each section of the track.

But everything is a compromise, so sometimes you'll have to sacrifice performance on one section of the track to gain a better overall time. You should shoot for the lowest lap times and not worry about some sections where the gearing feels wrong. Of course these recommendations must be tempered against your ability the actual layout of the track (long, short, hilly, etc.), and your riding style. But generally, these recommendations will suit most conditions and most riders.

Whether or not it's worth the effort and time it takes to swap to gearing that might help you pick off a position or two at the finish of your next moto is up to you.

Choosing the correct tire tread pattern and rubber compound can make the difference between finishing first or somewhere in the pack. The tires your CRF comes equipped with are a perfect "happy medium" for the variety of soil conditions the majority of riders are likely to encounter.

Motocross tire design has developed into an extremely intense area of study. The descriptions given here offer CRF riders a very basic knowledge of the factors involved in tire design so the proper tires can be utilized and the best possible competition result achieved. More tire information is available in the Maintenance section, page 10. The most complete information should be obtained from the various tire manufacturer representatives and dealers.

- Hard, Slick Terrain requires tires with many relatively short knobs that are close together in order to obtain the largest possible contact patch on the surface. The rubber compound needs to be softer for hard ground in order to hook up, but not so soft that the knobs easily roll over and keep you from holding your line. These tires tend to wear more quickly than some because of the combination of soft rubber and hard terrain.
- Very Tacky Soil or Muddy Courses require a more open tread pattern to avoid clogging. The rubber compound for these conditions can be harder to prevent the relatively long knobs from bending back under acceleration or wearing quickly.
- Loose and Sandy Soil conditions are best handled with a tire that is similar in construction to those needed for tacky soil and mud, but with a few more knobs.

Don't stray from the factory recommended sizes since this may affect handling and even acceleration.

10. MAINTENANCE, TUNING & RACING LOGBOOK

Any serious racing effort relies heavily on knowledge gained and compiled from previous racing events. Information such as what gearing was used, weather/altitude & jetting, which tire worked best and what suspension settings you used during the day may all be valuable factors next time you race at that particular track or one that is similar.

The best way to organize the many bits of information that led to your best competition effort at a given circuit under specific conditions, is to record your component settings, adjustments and comments in a Maintenance, Tuning & Racing Logbook.

A logbook can remind you when necessary maintenance was performed, when it will be necessary again, and when and specifically what adjustments were made for particular tracks. Also and most important, whether or not those specific adjustments or component selections were successful. A logbook can remind you to change suspension, gearing, tires and jetting to the settings that worked well in the past at any given race track. It can even remind you where on the course your competition was nearly able to pass you on the final lap, so you'll be forewarned.

Timekeeping

This Manual lists maintenance intervals for every-so-many races or every-so-many hours of running. Because all races are not the same, the most effective way to schedule maintenance is by the hours you have run your CRF.

An official "guestimate" is close enough for our timekeeping purposes. You may choose to record your time the same way aircraft operators do (but without the benefit of an electrical hourmeter). All running time is broken down into hours and tenths of an hour (each six minutes represents one tenth of an hour).

Maintenance Records

Regular Maintenance items you'll want to record in your logbook should include:

- Dates and Results of Valve Clearance, Cylinder, Piston and Ring Examinations
- Patterns for Frequency of Need for Decarbonization With a Particular Oil
- When you Last Performed Shock Linkage and Swingarm Pivot Bearing Maintenance
- Engine Transmission, Fork and Shock Oil Changes
- Chain, Sprocket, Chain Guide and Slider Replacements
- Coolant Changes and Related Component Replacements
- Spark Plug, Brake Pad and Control Cable Replacements.

In addition, you should record any irregularities noted in component wear so you'll remember to keep a close eye on these areas in the future.

Tuning Records

Some of the Tuning Information you'll want to keep track of in your logbook should include which combination of settings or components worked best at a particular location and may again under similar conditions. Items such as:

- Basic Track Conditions, Altitude of the event, and Temperature for practice and each moto
- Suspension Settings and Chassis Adjustments that were tested and selected
- Alternate Gearing choices and which was most suitable
- Tire Selection and Air Pressure
- Carburetion Changes

Racing Records

Information worth recording for this section of your logbook may include:

- Your Placing in Each Moto and Overall Finishing Position.
- Thoughts on what you could do to Improve Your Performance next time.
- Notes on any Patterns noted In Choice of Starting Gate Positions or In Riding Portions of the Course as the day progresses that may prove helpful in future events.
- Any Places on the course where you Chose the Wrong Line and were passed too easily.
- Notes on Strategy used by your competition or by riders in another event that are worth remembering.

This is an example of how to keep track of the running time on the engine and suspension components, your racing results, what adjustments and maintenance items were performed and what components are replaced on that particular day.

Consider using different color ink pens or pencils to record specific, important information on specific subjects. For instance, running time could be recorded in black, racing results in blue, jetting changes could be in red, and suspension/chassis settings and gearing selections in green. This will help you identify these items at a glance.

Resale Value

Although your racing log can be critically important in the development of your racing endeavors, accurate maintenance records may also be the deciding sales point to the next owner, especially if the market is full of many other used race motorcycles.

11 . SPARE PARTS & EQUIPMENT

There are a number of spare parts you should take to the track to help ensure that you get in a full day of riding. In addition to the usual nuts, bolts, washers, screws, cotter pins, safety wire, plastic tie-wraps, hose clamps, silicone sealer, contact cleaner and greases consider the following:

BASIC SPARE PARTS

Spark Plugs
Air Cleaner (Clean & Oiled, Sealed in a Plastic Bag)
Optional Carburetor Jets
Chain & Masterlinks
Chain Guide Slider
Chain Guide
Chain Rollers
Inner Tubes (F & R)
Fenders
Front & Side Number Plates
Handlebar
Grips
Levers (Brake, Clutch & Hot start)
Clutch Lever Handlebar Mount
Clutch Cable
Hot Start Cable
Throttle
Throttle Cable
Shift Pedal
Brake Pedal
Spokes (F & R, each side)
Sprockets – Both Larger and Smaller Than Std.– For Gearing Changes & Collision Damage Replacement
Assorted Nuts, Bolts, Washers & Screws

SPARES (PREFERRED)

Front Brake Master Cylinder
Wheels & Tires (F & R, Mounted)
Clutch Plates & Transmission Oil
Top End – Complete
Radiator Hoses
Radiator Shrouds (L & R)
Footpegs
Front & Rear Brake Hoses
Seat
Ignition Components

GENERAL TOOLS

Sockets (3/8-inch drive)
Screwdrivers – Blade & Phillips No. 1, 2, 3
Wrench – Large, Adjustable
Wrenches – Open end and Box
Wrenches – Hex (Allen)
Wrench – Spoke
Torque Wrench (metric scale, click-stop-style)
Pliers – Standard, Needle-Nose, Channel-Lock-Type
Hammer – Plastic Head
Syringe With Adjustable Stop
Tire Pressure Gauge
Tire Irons
Tire Pump or Air Tank

BASIC TOOLS

Drop Light
Feeler Gauge Set
Pliers – Safety Wire
Pressure/Vacuum Testing Equipment (U.S.A. only)
Vernier Caliper (metric)
Authorized Honda Special Tools:
• Clutch Center Holder 07JMB-MN50301
• Gear Holder 2.5 07724-0010100
• Gear Holder 1.5 07724-0010200
• Flywheel Holder 07725-0040001
• Drive Pulley Puller 07933-1480000
• Attachment 07943-MF50200
• Lock Nut Wrench 07WMA-KZ30100
• Stopper Tool (Piston base) 07958-2500001
• Nipple Wrench 07JMA-MR60100
• Nipple Wrench 070MA-KZ30100
• 8 x 9 mm Wrench 07708-0030100
• Adjusting Wrench 07708-0030300

BASIC SUPPLIES

Pro Honda GN4, HP4 (without molybdenum additives) or HP4M (with molybdenum additives) 4-stroke Oil (Engine Oil)
Pro Honda HP Trans Oil or Pro Honda GN4 or HP4 (without molybdenum additives only) 4-stroke Oil (Transmission Oil)
Pro Honda HP Fork Oil 5W
Honda Brake Fluid
Pro Honda Chain Lube
Pro Honda Foam Filter Oil
Honda Contact Cleaner
Honda Dielectric Compound
Honda Hand Grip Cement
Honda Hondalock
Honda Moly 60 Paste (U.S.A. only) or molybdenum disulfide paste (containing more than 40% molybdenum disulfide additive)
White Lithium Grease
Wheel Bearing Grease
Silicone Sealer
Safety Wire
Mechanic's Wire
Duct Tape
Pro Honda 50/50 Antifreeze
Electrical tape

12. TROUBLESHOOTING

NOTE:

- The items that are serviceable using this Manual are followed by the page number reference in parenthesis. The items that require use of the Honda Service Manual are followed by an asterisk.

POOR PERFORMANCE AT LOW AND UNSTABLE IDLE SPEED

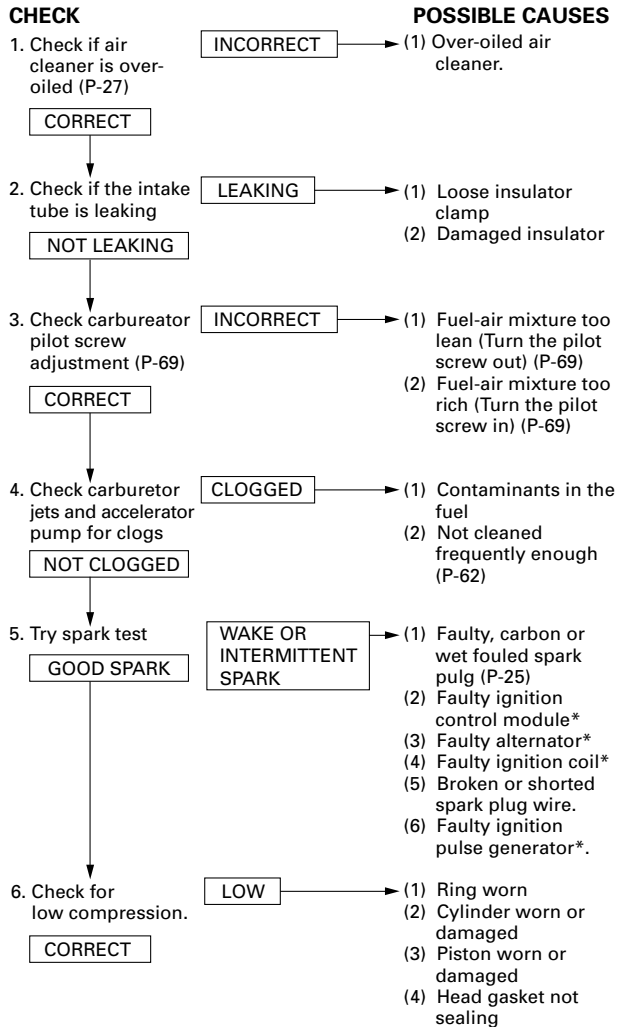

POOR PERFORMANCE AT HIGH SPEED

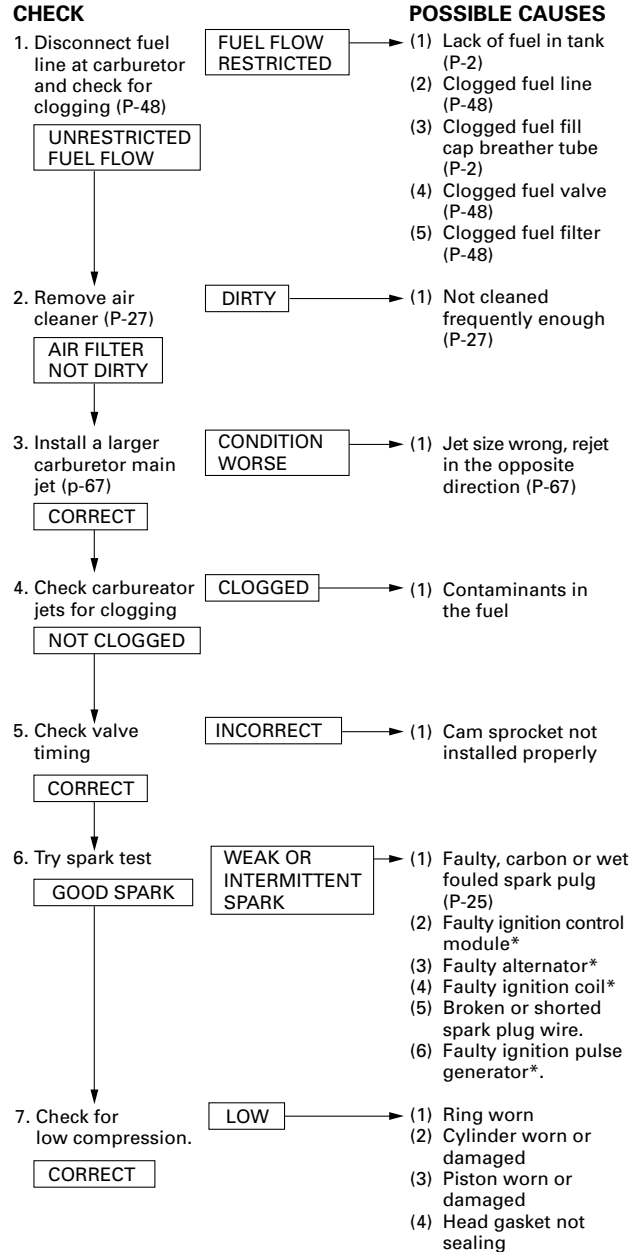

13. CLEANING

Clean your CRF regularly to protect the surface finishes and inspect for damage, wear, and oil leakage. When washing your CRF always use water or water and a mild detergent (such as dishwashing liquid) to avoid discoloring the seat and decals.

CAUTION:

- **Avoid spraying high pressure water (typical in coin-operated car washes) at the following areas:**

Wheel Hubs

Engine Stop Button

Muffler Outlet

Under Fuel Tank

Drive Chain

Under Seat

Brake Master Cylinder

Front Fork Dust Seals

1. After cleaning, rinse your CRF thoroughly with plenty of clean water. Strong detergent residue can corrode alloy parts.
2. Dry your CRF, start the engine, and let it run for several minutes.
3. Lubricate the drive chain immediately after washing and drying your CRF.
4. Test the brakes before riding your CRF. Several applications may be necessary to restore normal braking performance.

▲ WARNING

- **Braking performance may be impaired immediately after washing your CRF.**

Aluminum Frame Maintenance

Aluminum corrodes when it comes in contact with dust, mud and road salt.

To remove stains, use Scotch Brite Hand Pad #7447 (maroon) or equivalent.

Wet the pad and polish the surface using strokes parallel to the length of the frame.

Clean the frame using a wet sponge and a mild detergent, then rinse well with clean water. Dry the frame with a soft clean cloth, using strokes parallel to the length of the frame.

CAUTION:

- **Do not use steel wool to clean the frame as it could damage or discolor the frame surface.**
- **Muffler stain remover (Scotch Brite Hand Pad #7447-maroon) is for removing stains on the non-coated aluminum frame only.**

Exhaust Pipe Maintenance

The exhaust pipe is titanium and stainless steel, but may become stained by oil or mud.

Remove heat stains with a liquid kitchen abrasive.

14. STORAGE

Extended storage, such as for winter, requires that you take certain steps to reduce the effects of deterioration from nonuse of your CRF. In addition, necessary repairs should be made BEFORE storing your CRF otherwise, these repair may be forgotten by the time your CRF is removed from storage.

TO PREPARE THE MOTORCYCLE FOR STORAGE

1. Completely clean all parts of your CRF. If your CRF has been exposed to sea air or salt water, wash it down with fresh water and wipe dry.
2. Change the engine oil and filter (page 21).
3. Change the transmission oil (page 23).
4. Drain the fuel tank and carburetor into an approved gasoline container. Turn the fuel valve OFF and remove the carburetor drain bolt. Drain gasoline into an approved container. Reinstall the drain bolt.

▲ WARNING

- **Gasoline is extremely flammable and is explosive under certain conditions. Perform this operation in a well-ventilated area with the engine stopped. Do not smoke or allow flames or sparks in the area where gasoline is drained or stored and where the fuel tank is refueled.**

5. Remove the bolt and right engine guard. Remove the radiator cap and coolant drain bolt at the water pump to drain coolant. After the coolant has been completely drained, ensure that the drain bolt sealing washer is in good condition and reinstall the drain bolt and radiator cap. Install the right engine guard and bolt.

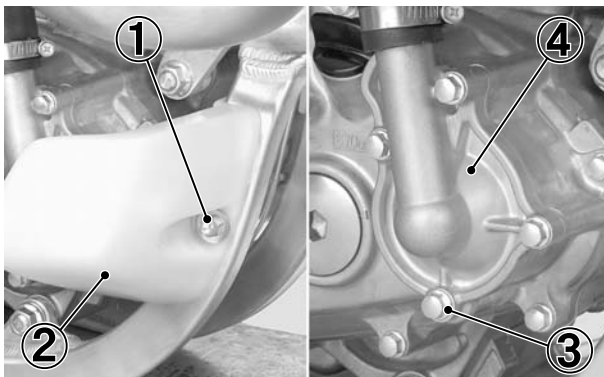

- (1) BOLT
(2) RIGHT ENGINE GUARD
(3) COOLANT DRAIN BOLT
(4) WATER PUMP

6. Lubricate the drive chain.
7. Remove the spark plug and pour a tablespoon (15 – 20 cc) of clean engine oil into the cylinder. With the spark plug grounded or the Engine Stop Button pressed in, crank the engine several times to distribute the oil, then reinstall the spark plug.
8. Inflate the tires to their recommended pressures.
9. Place your CRF on the optional Honda workstand or equivalent to raise both tires off the ground.
10. Stuff a rag into the silencer outlet. Then tie a plastic bag over the end of the silencer to prevent moisture from entering.
11. Cover your CRF and store in a place which is free of humidity and dust.

REMOVAL FROM STORAGE

1. Uncover and clean your CRF. Change the engine oil and transmission oil if more than 4 months have passed since the start of storage.
2. Uncover the end of the silencer and remove the rag from the silencer outlet.
3. Fill the fuel tank with recommended fuel (page 2).
4. Pour a fresh recommended coolant mixture (page 24) slowly into the radiator filler hole up to the filler neck.

Capacity:

1.18 US qt (1.12 liter, 0.99 Imp qt.) at disassembly
1.09 US qt (1.03 liter, 0.91 Imp qt.) at draining

- Lean your CRF slightly right and left several times to bleed trapped air in the cooling system. If the coolant level lowers, add coolant and repeat the above procedure. Install the radiator cap securely.
5. Perform all maintenance checks (page 11).

15. WIRING DIAGRAM

ENGINE STOP SWITCH

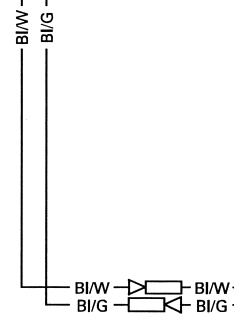

IGNITION CONTROL MODULE



| | | | |
|----|--------|----|-------------|
| Bl | BLACK | Br | BROWN |
| Y | YELLOW | O | ORANGE |
| Bu | BLUE | Lb | LIGHT BLUE |
| G | GREEN | Lg | LIGHT GREEN |
| R | RED | P | PINK |
| W | WHITE | Gr | GRAY |

COLOR COMB : GROUND/MARKING

| ENGINE STOP SWITCH CONTINUITY | | |
|-------------------------------|------|------|
| | E | IG |
| FREE | | |
| PUSH | ○—○ | |
| COLOR | BI/G | BI/W |

FRAME BODY GROUND

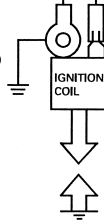

THROTTLE SENSOR

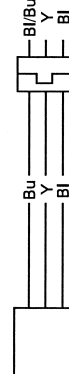

IGNITION PULSE GENERATOR

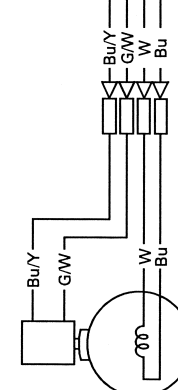

ALTERNATOR

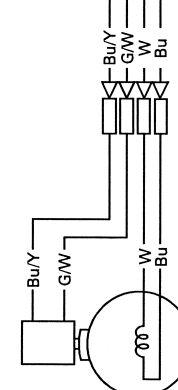

16. INDEX

| | | | |
|--|-----|---|-----|
| Additional individualized adjustments | 8 | Hot start | 6 |
| Adjustment for personal fit | 8 | Ignition | 26 |
| After cleaning lubrication | 13 | Maintenance preparations | 17 |
| After race lubrication | 13 | Maintenance procedures | 21 |
| After race maintenance | 13 | Maintenance schedule | 11 |
| Air cleaner | 27 | Maintenance, tuning & racing logbook | 96 |
| Basic operation | 2 | Nuts, bolts, fasteners | 58 |
| Between moto/between practice and moto maintenance | 12 | Operating instructions | 2 |
| Break -in procedure | 3 | Optional parts list | 10 |
| Brake pedal height | 7 | Piston/piston rings/piston pin | 39 |
| Brakes | 51 | Poor performance at high speed | 99 |
| Carburetor adjustment | 61 | Poor performance at low and unstable idle speed | 99 |
| Carburetor | 61 | Pre-ride inspection check list | 11 |
| Chassis adjustments for track conditions | 94 | Pressurized spray washers | 13 |
| Cleaning | 100 | Race sag | 71 |
| Clutch lever free play | 5 | Rear end | 94 |
| Clutch lever position | 5 | Rear suspension (Adjustment) | 72 |
| Clutch | 28 | Rear suspension (Inspection) | 50 |
| Condensation control | 13 | Removal from storage | 101 |
| Control cables | 57 | Routine cleaning | 13 |
| Control free play adjustment | 5 | Seat | 17 |
| Control positioning | 8 | Service and maintenance | 11 |
| Controls | 4 | Spare parts & equipment | 98 |
| Coolant | 24 | Spark plug coloring indications | 70 |
| Crankcase breather | 27 | Spark plug | 25 |
| Drive chain | 52 | Specifications | 9 |
| Drive chain rollers | 54 | Starting the engine | 2 |
| Drive chain sliders | 54 | Stopping the engine | 3 |
| Driven sprocket | 55 | Storage | 101 |
| Engine Idle Speed | 26 | Subframe | 19 |
| Engine oil | 21 | Suspension adjustment | 71 |
| Exhaust pipe/muffler | 55 | Suspension adjustment guidelines | 91 |
| Fork height/angle | 94 | Suspension adjustments relating specific track conditions | 90 |
| Front and rear wheels and tires | 49 | Throttle grip (Free play adjustment) | 6 |
| Front brake lever | 7 | Throttle grip (Inspection) | 47 |
| Front suspension (Adjustment) | 72 | Tire selection | 95 |
| Front suspension (Inspection) | 49 | Torque table | 58 |
| Fuel filter | 48 | Transmission oil | 23 |
| Fuel line | 48 | Troubleshooting | 99 |
| Fuel tank | 17 | Tuning for special conditions (Carburetor) | 70 |
| Fuel | 2 | Valve | 30 |
| Gearing selection | 94 | Wheel base | 94 |
| General maintenance | 14 | Wiring diagram | 102 |
| General service information | 12 | | |
| Handlebar and steering head bearings | 47 | | |
| Handlebar position, width & shape | 8 | | |

MEMO

17. AUTHORIZED MANUALS

The Service Manual (Publication Item No. 61MEN00 used by your authorized Honda dealer is available from Helm, Inc.

Also available, but not necessary to service your model is the Honda Common Service Manual (Publication No. 61CM001), which explains theory of operation and basic service information for various systems common to all Honda motorcycles, motor scooters and ATVs.

These Honda manuals are written for the professional technician, but most mechanically-capable owners should find them helpful if they have the proper tools and skills. Special Honda tools are necessary for some procedures.

| Publication Item No. | Description | Price Each* |
|----------------------|----------------------------------|-------------|
| 61MEN00 | 2002-2004 CRF450R Service Manual | \$48.00 |
| 61CM001 | Common Service Manual | \$48.00 |
| 31MEN600 | 2004 CRF450R Owner's Manual | \$16.00 |

**Prices are subject to change without notice and without incurring obligation.*

Order On-Line: www.helminc.com

Order Toll Free: 1-888-CYCLE93 (1-888-292-5393)

(NOTE: For Credit Card Orders Only)
Monday – Friday 8:00 AM – 6:00 PM EST

OR

By completing this form you can order the materials desired. You can pay by check or money order, or charge to your credit card. Mail to Helm, Incorporated, at the address shown on this order form.

| Publication Item No. | Item Description | Qty | Price Each* | Total Price |
|--|------------------|----------------------------------|-------------|-------------|
| | | | | |
| | | | | |
| | | | | |
| | | | | |
| *Prices are subject to change without notice and without incurring obligation. Orders are mailed within 10 days. Please allow adequate time for delivery. | | Sub Total | | |
| | | Mich. Purchases Add 6% Sales Tax | | |
| | | Handling Charge | | \$4.00 |
| | | Grand Total | | |

S
H
I
P
T
O

NOTE: Dealers and Companies, please provide dealer or company name, and also the name of the person to whose attention the shipment should be sent. For purchases outside U.S.A., please write to the address shown below for a quotation.

Customer Name _____

Attention _____

Street Address – No P.O. Box Number _____ Apt. # _____

City _____ State ____ Zip Code _____

Daytime Telephone Number () _____

P
A
Y
M
E
N
T

Check or money order enclosed payable to Helm, Inc. U.S. funds only. Do not send cash.

Master Card
 VISA
 Discover
 Check here if your billing address is different from the shipping address shown above.

Account Number

Expiration Date: Mo. Yr.
 —

Customer Signature _____ Date _____

These Publications cannot be returned for credit without receiving advance authorization within 14 days of delivery. On returns, a restocking fee may be applied against the original order.

HELM P.O. BOX 07280 • DETROIT • MI 48207

MEMO

Free Manuals Download Website

<http://myh66.com>

<http://usermanuals.us>

<http://www.somanuals.com>

<http://www.4manuals.cc>

<http://www.manual-lib.com>

<http://www.404manual.com>

<http://www.luxmanual.com>

<http://aubethermostatmanual.com>

Golf course search by state

<http://golfingnear.com>

Email search by domain

<http://emailbydomain.com>

Auto manuals search

<http://auto.somanuals.com>

TV manuals search

<http://tv.somanuals.com>