

SETTING UP YOUR NEW SNOWTHROWER

Honda HS520A/HS520AS

Serial Number: SZBG-1000001 ~ Forward

Before Using Your Snowthrower

Before using the snowthrower, all snowthrower operators must read the following chapters and sections of the Owner's Manual:

- SNOWTHROWER SAFETY
- CONTROLS
- BEFORE OPERATION
- OPERATION
- MAINTENANCE SCHEDULE

Tools Required

12 mm wrench, 10 mm wrench, and a Phillips screwdriver

Unpacking

1. Remove all the cardboard. Inspect the loose parts. Missing parts can be obtained from the Honda dealer who sold you the snowthrower.

Qty.	Description	Part number
4	Curved head bolt 8 x 40 mm	90109-VA4-000
4	Flange nut, 8 mm	94050-08000
4	Curved washer, 9 mm	90501-898-000
3	Phillips head shoulder screw 6 x 12 mm	90112-V10-000
3	Flange nut, 6 mm, Nylock	90303-V10-000
2	Cable tie (AS model only)	32901-VB5-A00
2	Key (AS model only)	35110-766-003
1	Honda Genuine oil	08207-5W30

2. Loosen and remove the curved-head bolt, flange nut, and starter bracket from the lower handlebar. Do not discard the hardware.

Assembly

1. Install the handlebar with the hardware shown. Tighten the flange nuts securely.

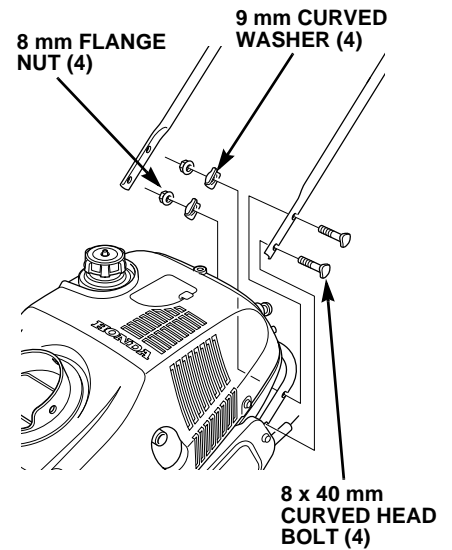

2. Pull the clutch cable enough to insert the "Z" fitting on the cable through the auger clutch lever as shown here. Check the lever free play as shown on page 3.

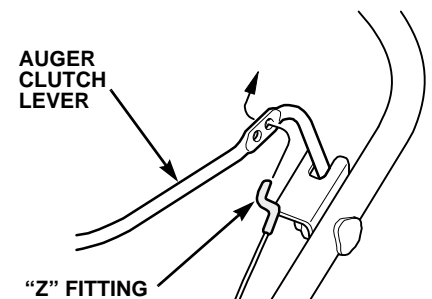

3. **HS520A:** Install the starter bracket using the hardware removed from step 2.

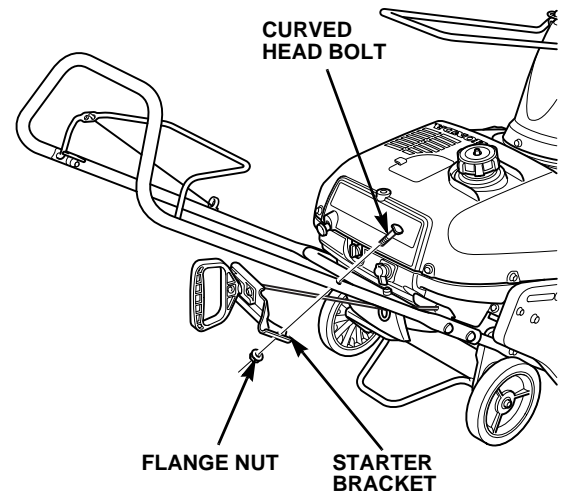

3. **HS520AS:** Snap the starter rope into the rope guide on the handlebar and secure the electric start wire using the two cable ties as shown. Trim the cable ties to a length of 3/8 inch (10 mm).

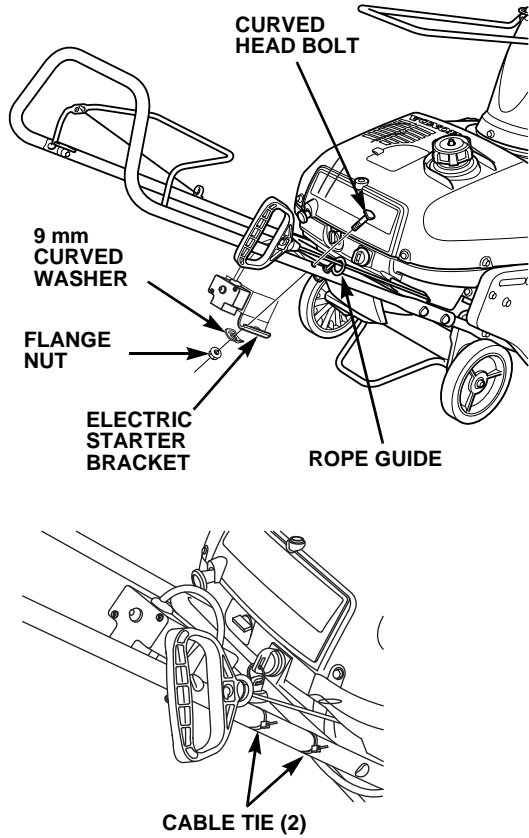

4. Install the discharge chute using the three 6 mm Phillips-head screws and 6 mm self-locking nuts. Make sure the screws go on the inside and the nuts on the outside. **Tighten the nuts securely: HEX NUT TORQUE: 7 ft-lbs (10 N•m)**

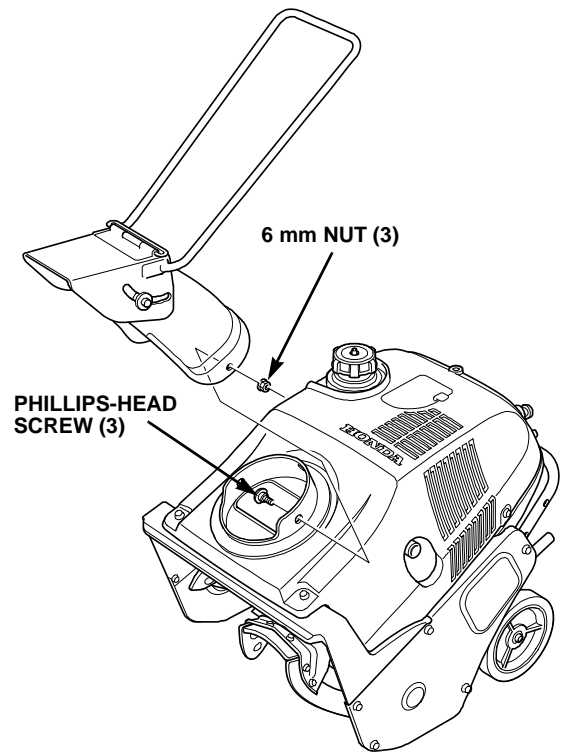
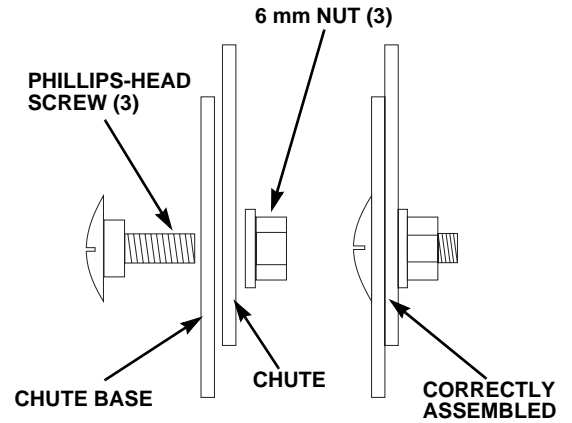

5. Lift the spark plug door and attach the spark plug cap to the spark plug.

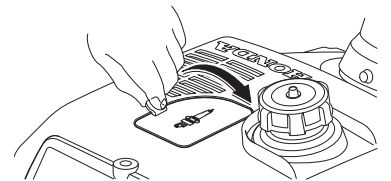

6. Remove any packing material from the side of the snowthrower.

Clutch Lever Free Play

Inspection

1. Move the clutch lever until you feel resistance from the cable. Measure the distance as shown.

CLUTCH LEVER DISTANCE:
7-1/2 ~ 8 inches
(190 ~ 205 mm)

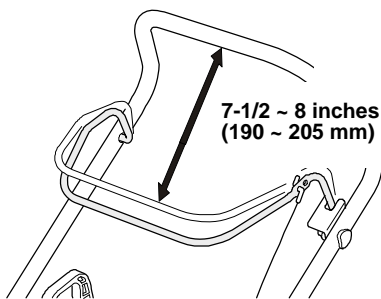

Adjustment

1. Pull the spring cover up to expose the tension spring. Change the position of either the cable or spring on the metal plate so the clutch lever distance is correct.

Moving the spring makes a 1/4 inch (6 mm) change, while moving the cable makes a 3/8 inch (10 mm) change in the length of the cable.

2. Slide the cover back over the spring.

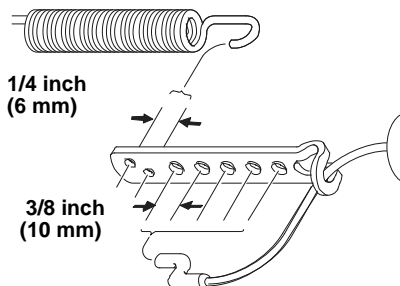
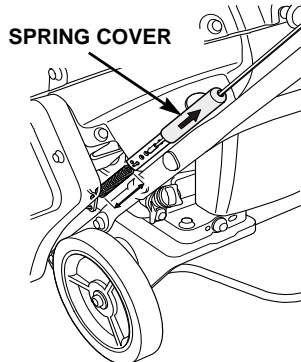

Engine Oil

1. The snowthrower is shipped **WITHOUT OIL** in the engine.
2. Add enough of the recommended SAE 10W-30 API service category SJ or later oil to bring the oil level to the top of the filler hole. A bottle of oil is included in the box with your snowthrower.

All Honda engines are run at the factory prior to packaging. Most of the oil is removed prior to shipment; however, some oil remains in the engine. The amount of oil left in the engine varies.

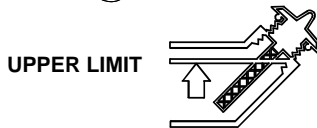
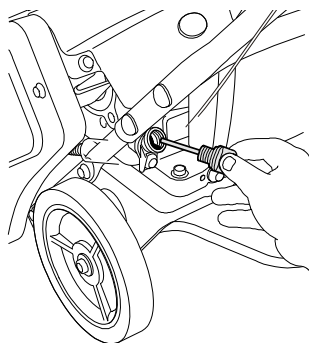

Fuel

This engine is certified to operate on unleaded gasoline with a pump octane rating of 86 or higher.

We recommend refueling after each use to minimize the air present in the fuel tank.

Refuel in a well-ventilated area with the engine stopped. Never refuel the engine inside a building where gasoline fumes may reach flames or sparks.

Please Register Your Snowthrower

If your dealer did not collect registration information from you, please take a few minutes and register your purchase with Honda. This allows us to contact you with any important updates regarding your snowthrower. Your information will remain confidential. It will not be released to any other company or organization. Please note registration is not required to obtain warranty service.

You can register by completing and mailing the included registration card in the Owner's Manual, or go online to www.HondaPowerEquipment.com and click on Product Registration.

Free Manuals Download Website

<http://myh66.com>

<http://usermanuals.us>

<http://www.somanuals.com>

<http://www.4manuals.cc>

<http://www.manual-lib.com>

<http://www.404manual.com>

<http://www.luxmanual.com>

<http://aubethermostatmanual.com>

Golf course search by state

<http://golfingnear.com>

Email search by domain

<http://emailbydomain.com>

Auto manuals search

<http://auto.somanuals.com>

TV manuals search

<http://tv.somanuals.com>