

# HONDA

## Lawn Tractor

### HT3813

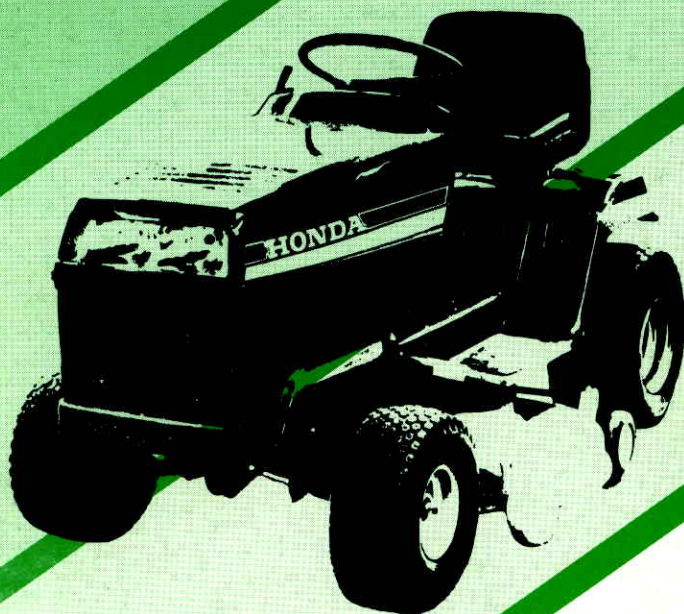

OWNER'S MANUAL

---

Thank you for purchasing a Honda Lawn Tractor.

This manual covers the operation and maintenance of the Honda HT3813 Lawn Tractor, type SA (side discharge).

Honda Motor Co., Ltd. reserves the right to make changes at any time without notice and without incurring any obligation.

No part of this publication may be reproduced without written permission.

This manual should be considered a permanent part of the lawn tractor and should remain with the lawn tractor when sold.

Pay special attention to statements preceded by the following words;

**WARNING** Indicates a strong possibility of severe personal injury or loss of life if instructions are not followed.

**CAUTION:** Indicates a possibility of personal injury or equipment damage if instructions are not followed.

**NOTE:** Gives helpful information.

If a problem should arise, or if you have any questions about the lawn tractor, consult an authorized Honda dealer.

**WARNING** Honda lawn tractors are designed to give safe and dependable service if operated according to instructions. Read and understand the Owner's Manual before operating the lawn tractor. Failure to do so could result in personal injury or equipment damage.

HONDA MOTOR CO., LTD. 1985, ALL RIGHTS RESERVED

# CONTENTS

---

1. WARNING LABEL LOCATIONS .....	3
2. GENERAL SAFETY .....	4
3. COMPONENT IDENTIFICATION .....	6
4. CONTROLS .....	8
5. PRE-OPERATION CHECKS .....	13
6. OPERATION .....	22
• High altitude operation	
• Starting the engine	
• Mowing	
• Stopping the engine	
7. TRANSPORTING/STORAGE .....	30
8. MAINTENANCE .....	35
9. WIRING DIAGRAM .....	51
10. TROUBLE SHOOTING .....	52
11. SPECIFICATIONS .....	55
12. WARRANTY SERVICE .....	56

# 1. WARNING LABEL LOCATIONS

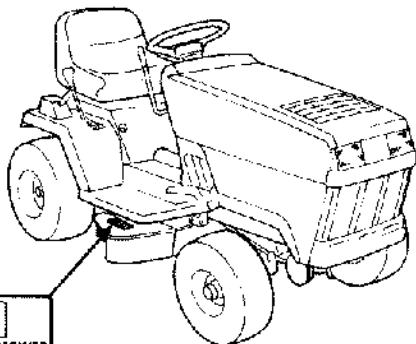

## **WARNING**

- KEEP HANDS AND FEET AWAY FROM MOWER OR DISCHARGE GUARD WHILE BLADES ARE TURNING.
- DO NOT OPERATE MOWER WITHOUT DISCHARGE GUARD.
- CLEAR LAWN OF DEBRIS AND OBJECTS.
- DO NOT MOW NEAR PEOPLE OR PETS. OBJECTS MAY BE THROWN FROM MOWER.

**CAUTION**  
CLEAN THE RADIATOR SCREEN, BEFORE OPERATING AND/OR WHEN THE OVERHEAT INDICATOR LAMP IS ON AND THE BUZZER SOUNDS

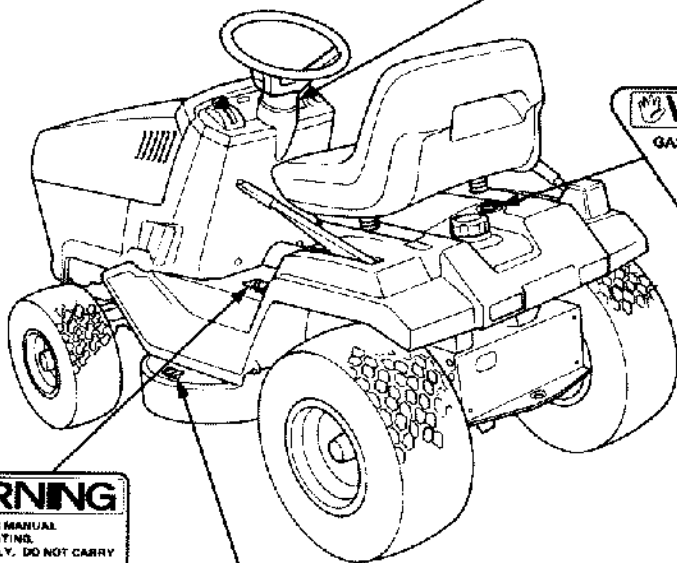

## **WARNING**

GASOLINE IS FLAMMABLE. STOP ENGINE, AVOID HEAT, SPARKS, AND OPEN FLAME WHEN REFUELING.

## **WARNING**

- READ OWNER'S MANUAL BEFORE OPERATING.
- OPERATOR ONLY. DO NOT CARRY PASSENGERS.
- MAXIMUM SAFE OPERATING ANGLE 10 DEGREES (17 X GRADE)

-  15° MAX
- REDUCE SPEED WHEN TURNING OR OPERATING ON SLOPES.
- STOP ENGINE BEFORE REMOVING GRASS CATCHER OR CLEANING DISCHARGE CHUTE.
- KEEP ALL SHIELDS AND SAFETY DEVICES IN PLACE.
- KEEP PEOPLE AND PETS AT A SAFE DISTANCE WHILE OPERATING.
- THIS LAWN TRACTOR IS NOT LEGAL FOR USE ON PUBLIC STREETS OR HIGHWAYS.

## **WARNING**

KEEP HANDS AND FEET AWAY FROM ANY PART OF MOWER DECK WHILE BLADES ARE TURNING.

## 2. GENERAL SAFETY

---

### LAWN TRACTOR SAFETY

**WARNING** Operating a lawn tractor requires special efforts on your part to ensure your safety and the safety of others. Know these requirements before you operate the lawn tractor.

### SAFE OPERATING RULES

- Always make a pre-operation inspection (page 13) before you start the engine. You may prevent an accident or equipment damage.
- Know how to stop the engine and blades quickly. Thoroughly understand operation of all controls.
- Never permit anyone to operate the lawn tractor without proper instructions.
- Do not allow passengers to ride on the tractor or any of its attachments.
- Children should not be permitted to operate this lawn tractor.
- To prevent serious injury, never put your hands or feet under the cutter deck.
- Do not remove any guards, warning labels, shields or safety devices. They are installed for your safety.
- This lawn tractor is intended for use on relatively flat terrain. Do not use on sloped surfaces exceeding 10 degrees (17% grade). This angle may be further reduced by the condition and type of surface.

Maximum safe operating angle

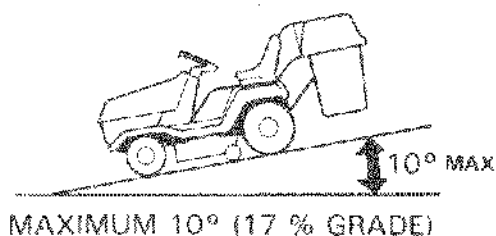

- If mowing on a sloping surface, always drive up and down the face of the grade. Never turn or drive across the face of the slope.
- To prevent loss of control or overturning, always reduce speed and exercise extreme caution when operating on sloping or uneven surfaces. Avoid turning or stopping on sloping surfaces; see page 27 for special instructions.
- Do not back down or rapidly accelerate up a sloping surface; see page 27 for special instructions.
- Watch out for rocks, roots, holes and other obstacles.

## BEFORE MOWING

- Always ensure the area in front of and behind the lawn tractor is clear of people, pets and debris before starting.
- Before mowing, always clear the lawn of stones, sticks or other debris. These objects could be thrown out by the spinning blades and cause an injury or equipment damage.
- Leaves, grass clippings, oil and other combustible materials can become a fire hazard. Be sure to keep the engine compartment, the upper cutter deck surfaces and the belt and pulley areas clean.
- Select a safe operating speed (gear position) for the area to be mowed. 5th gear should be used only while driving to and from storage area.
- Use extra care when pulling a trailer or when using optional attachments.
  - a. Be sure that any accessories (trailer hitch, etc.) are securely mounted, and that they do not interfere with the safe operation of the tractor.
  - b. Reduce operating speeds when using attachments, and limit loads to those you can safely control.
  - c. Use care when backing, and avoid making sharp turns.
- Stop engine before removing the grass bags or cleaning the discharge chute.
- Check the condition of the grass catcher bags frequently. For your safety, replace any bag that is worn or deteriorated.
- Always empty the grass bags when mowing is completed. Damp, decomposing grass clippings generate heat and can become a fire hazard.
- To reduce the possibility of fire, allow the engine and exhaust system to cool before storing the tractor in an enclosed space or near combustible materials.

### 3. COMPONENT IDENTIFICATION

---

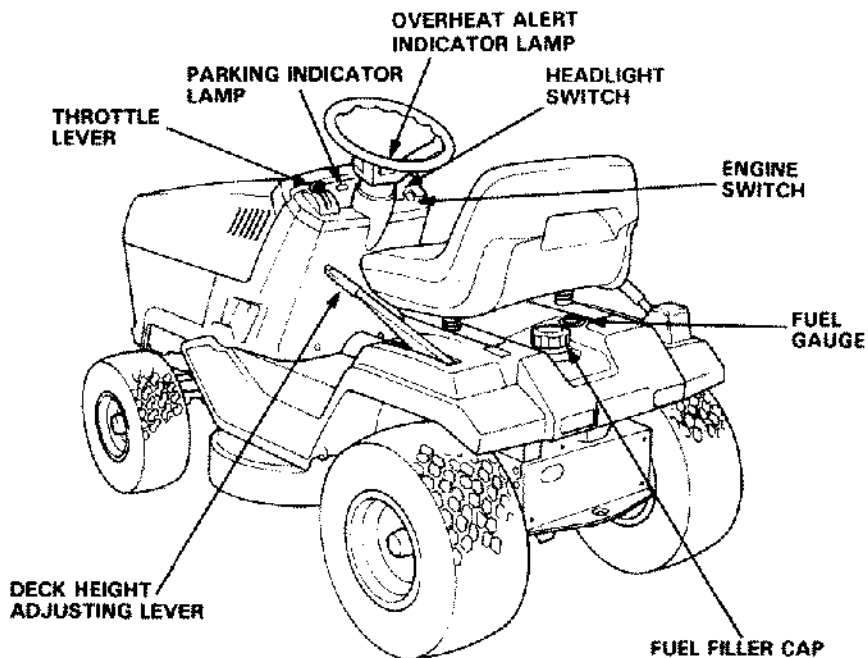
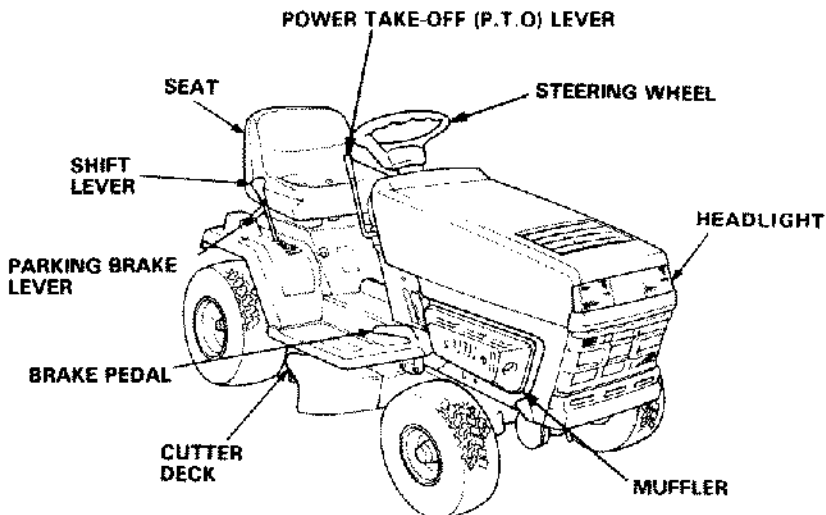

## Engine compartment

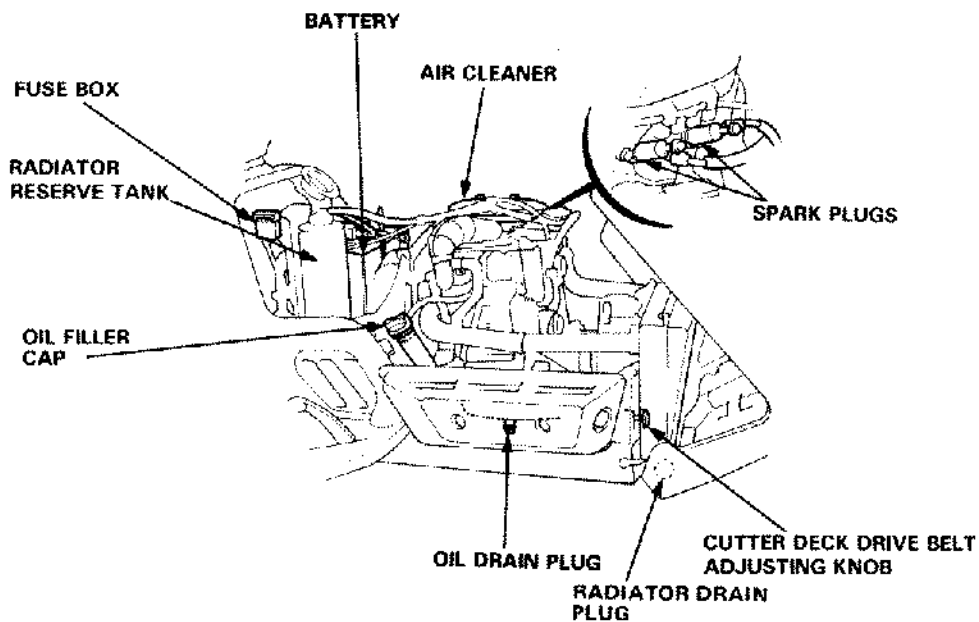
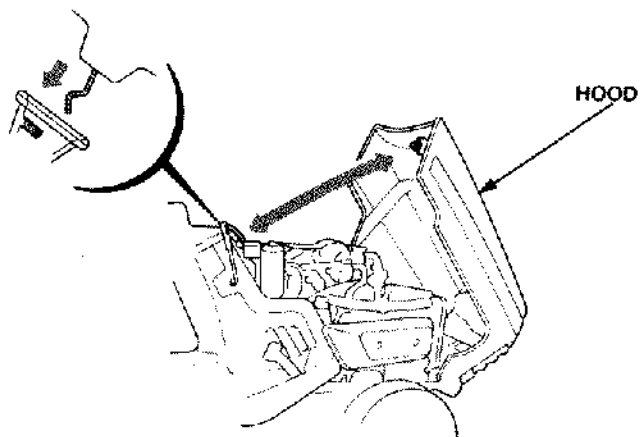



## 4. CONTROLS

### 1. Engine switch



Always remove the key from the engine switch whenever the lawn tractor is unattended to prevent children or unauthorized persons from starting the engine.

This lawn tractor is equipped with an automotive type ignition switch, which controls all the electrical circuits. The switch is located on the right-hand side of the control panel.

Key positions: "START" to start the engine

"ON" to run the engine after starting

"OFF" to stop the engine.

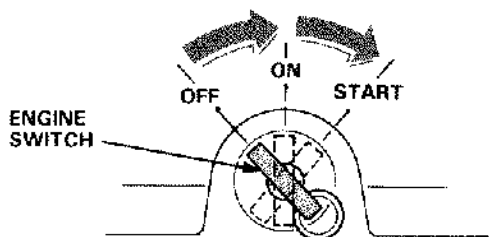

**NOTE:** The starter motor will not work unless the shift lever is in NEUTRAL and the P.T.O lever is in the OFF (Disengaged) position.

### 2. Throttle lever

The throttle lever controls engine speed from SLOW (idle) to FAST (max speed), and START (CHOKE) is for starting a cold engine.

**NOTE:** When the engine is warm or the air temperature is high, move the throttle to SLOW as soon as the engine starts.

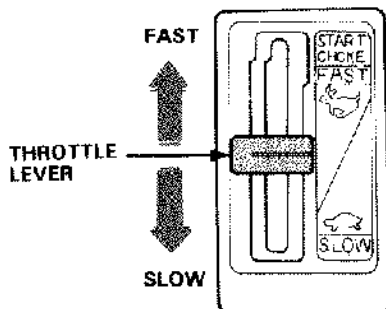

### 3. Cutter deck height adjusting lever

This lever is used for setting grass cutting height. To adjust the cutting height, press the set button, raise or lower the lever until the desired cutting height appears on the indicator, and then release the set button. Cutting height: 1-1/2, 2.0, 2-1/2, 3.0, 3-1/2, 4.0 in.

**CAUTION:** Fully raise the cutter deck for maximum ground clearance when driving the tractor to and from the mowing area.

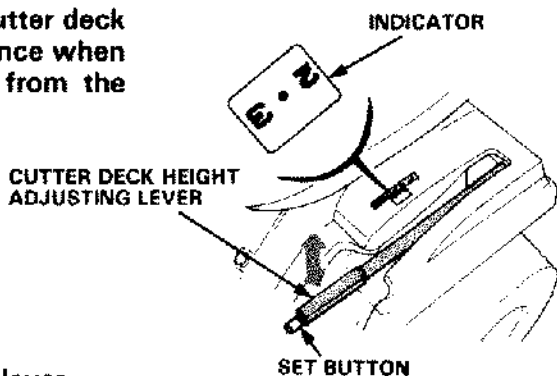

### 4. Power Take-Off (P.T.O) lever

This lever engages and disengages the power take-off clutch to drive the blades.

Lever positions: ON (Engaged)..... Blades turn  
OFF (Disengaged) ..... Blades stop

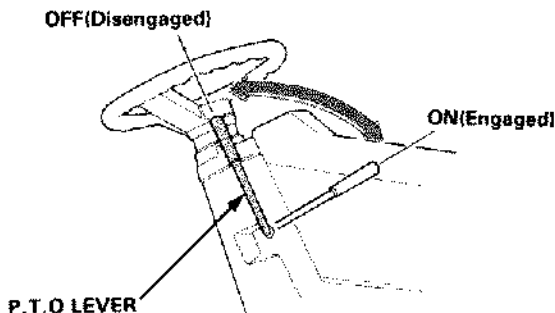

**NOTE:** An interlock switch prevents the engine from starting unless the P.T.O. lever is in the OFF position.

## 5. Shift lever

This lever is used to select one of the five forward speeds, neutral, or reverse. The drive clutch automatically disengages while the lever is being moved. The clutch will then engage automatically when put into gear unless the brake pedal is depressed.

**CAUTION:** Bring the tractor to a complete stop before shifting from a forward speed to reverse, or from reverse to a forward speed. Shifting between forward and reverse speeds while the tractor is moving can cause transmission damage.

When shifting from one forward speed range to another while moving, do not force the shift lever and do not shift up or down more than one slot at a time. Do not operate the shift lever on the slope.

**NOTE:** The tractor will pull away from a stop in any speed range. No shifting is necessary.

5th speed is not recommended for mowing but may be used for driving the tractor from one area to another.

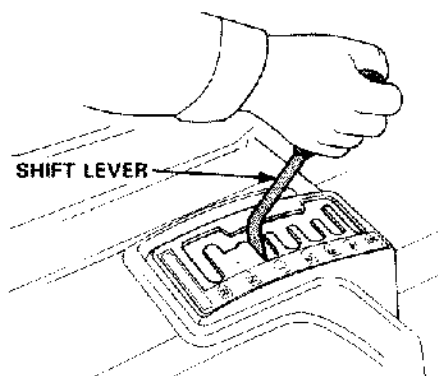

## 6. Headlight switch

The switch turns the headlights ON and OFF.

### CAUTION:

- To avoid discharging the battery, run the engine with the throttle in the FAST position when using the headlights.
- Shift the transmission to a lower speed range to maintain a safe speed when visibility is poor.

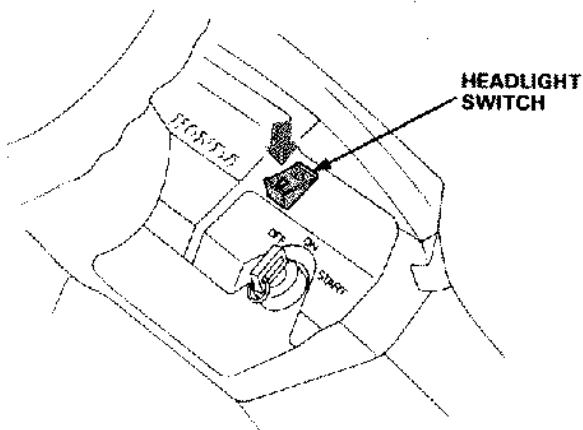

## 7. Brake pedal

Depressing the pedal will first disengage the tractor drive clutch. As you continue to depress the pedal, the brake will be applied to stop the tractor.

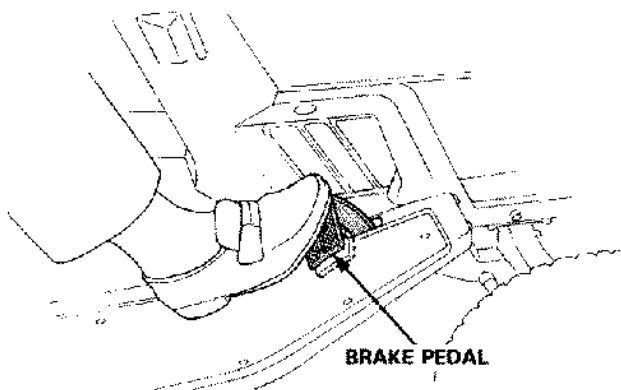

When the pedal is released, the clutch will engage automatically.

## 8. Parking brake lever

This lever is used to set the brake when the lawn tractor is parked. Pull the lever fully up until the ratchet locks, and be sure that the parking indicator lamp on the control panel is ON.

**NOTE:** The parking brake lever does not operate the automatic clutch. Always put the transmission in neutral, or turn off the engine switch before setting the parking brake. A warning buzzer will sound if the parking brake is engaged while the transmission is in gear and the engine switch is ON.

Pull the lever up slightly and press the lever button, lower the lever while holding the button in. The parking indicator lamp should go off.

**Warning** Operating the lawn tractor with the parking brake set will result in severe damage to the brake lining, and could lead to a complete brake system failure.

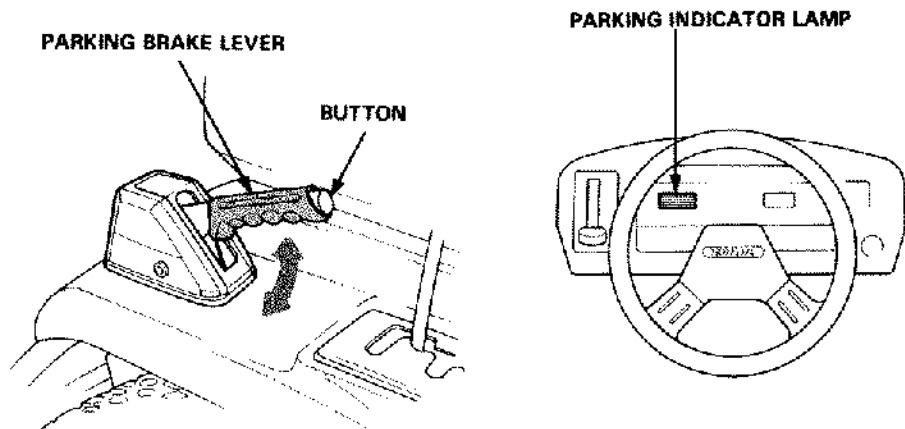

## 5. PRE-OPERATION CHECKS

**WARNING** To prevent accidental start-up, remove the engine switch key, and disconnect the spark plug caps before performing the pre-operation inspection.

### 1. Check the radiator screen.

**CAUTION:** If the engine has been running, the radiator will be very hot; allow it to cool before proceeding.

Lift the screen out of its holder. Remove any dirt and clippings from the screen and the front of the radiator, and then reinstall the screen.

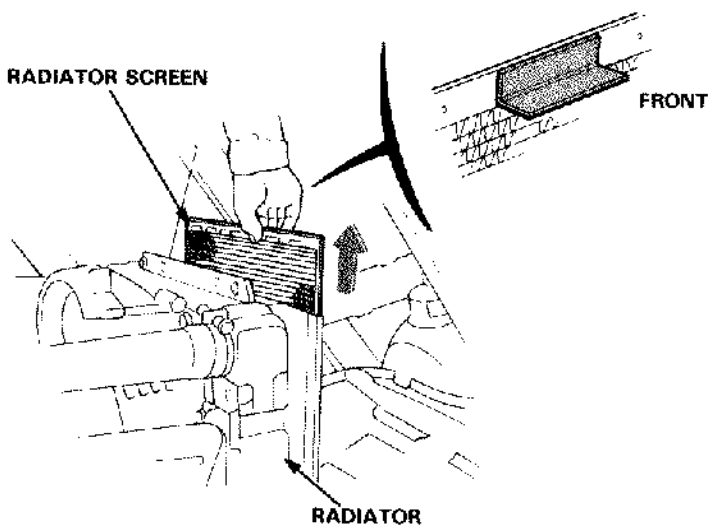

## 2. Check the engine oil level

### CAUTION:

- Engine oil is a major factor affecting engine performance and service life. Non-detergent oil and 2-stroke engine oil are not recommended.
  - Running the engine with insufficient oil can cause serious engine damage.
- a. Place the lawn tractor on a level surface.
  - b. Open the engine hood, remove the oil filler cap and wipe the dipstick clean.
  - c. Insert the dipstick into the oil filler neck, but do not screw it in.
  - d. Check the oil level shown on the dipstick. If near or below the lower level mark, fill to the upper level mark with the recommended oil.

Use Honda 4-stroke oil, or an equivalent high detergent, premium quality motor oil certified to meet or exceed U.S. automobile manufacturers' requirements for service classification SE or SF (Motor oils classified SE or SF will show this designation on the container).

SAE 10W-40 is recommended for general, all-temperature use.

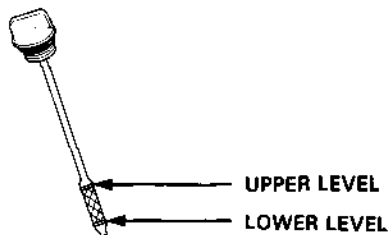
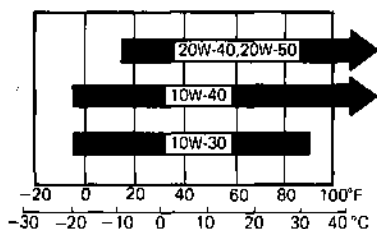
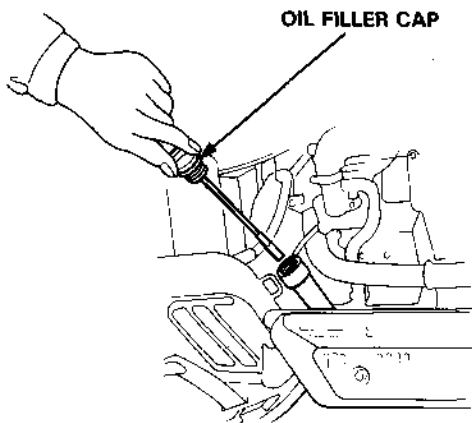

### 3. Check the fuel level

Raise the seat and check the fuel gauge.

Refill the tank if the fuel level is low.

Any automotive gasoline with a pump octane number ( $\frac{R + M}{2}$ ) of 86 or higher, or a research octane number of 91 or higher may be used (unleaded is preferred to minimize combustion chamber deposits).

Never use an oil/gasoline mixture or dirty gasoline. Avoid getting dirt, dust or water in the fuel tank.

After refueling, be sure to tighten the fuel tank cap firmly.

#### **WARNING**

- Gasoline is extremely flammable and explosive under certain conditions. Refuel in a well ventilated area with the engine stopped.
- Do not smoke or allow flames or sparks in the area where the lawn tractor is refueled or where gasoline is stored.
- Be careful not to spill fuel when refueling. Fuel vapor or spilled fuel may ignite; Wipe up any spilled fuel immediately, and make sure the area is dry before starting the engine.
- Do not overfill the tank. Fuel may expand and overflow. Make sure the filler cap is securely closed after refueling.

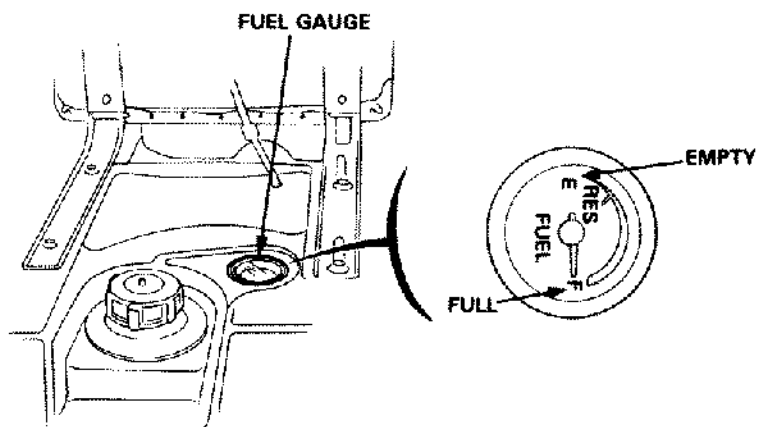



---

## **GASOLINES CONTAINING ALCOHOL**

If you decide to use a gasoline containing alcohol ("gasohol"), be sure its octane rating is at least as high as that recommended above. There are two types of "gasohol": that containing ethanol, and that containing methanol. Do not use gasohol that contains more than 10% ethanol. Do not use gasoline containing methanol (methyl or wood alcohol) that does not also contain cosolvents and corrosion inhibitors for methanol. Never use gasoline containing more than 5% methanol, even if it has cosolvents and corrosion inhibitors.

### **NOTE:**

- Fuel system damage or engine performance problems resulting from the use of such fuels is not covered under Power Equipment Warranties. Honda cannot endorse the use of fuels containing methanol since evidence of their suitability is as yet incomplete.
- Before purchasing fuel from an unfamiliar station, try to confirm whether the fuel contains alcohol, and to what percentage. If you notice any undesirable operating symptoms after using a gasoline that contains alcohol; or one that you think contains alcohol, switch to a gasoline that you know does not contain alcohol.

#### 4. Check the coolant level.

If there is no coolant in the reserve tank, check the cooling system for leaks and repair if necessary. Add coolant to the radiator, then check the coolant level in the reserve tank after the engine reaches operating temperature.

**WARNING** Never remove the radiator cap when the engine is hot. The coolant is under pressure and severe scalding could result.

When the engine is at operating temperature, the coolant level should be between the MIN and MAX marks on the reserve tank. If the level is near the MIN mark, add coolant to bring it up to the MAX mark.

#### Coolant Recommendation

Use high quality ethylene glycol antifreeze that is specifically formulated for use in aluminum engines. Mix the antifreeze with low-mineral drinking water or distilled water.

A 50/50 mixture of ethylene glycol antifreeze and water is recommended for most temperatures and provides good corrosion protection. A higher concentration of antifreeze decreases cooling efficiency and is recommended only if additional protection against freezing is needed. A concentration of less than 40% antifreeze will not provide proper corrosion protection.

**CAUTION:** The use of unsuitable antifreeze, hard water, or salt water may cause corrosion damage that will shorten the life of the engine.

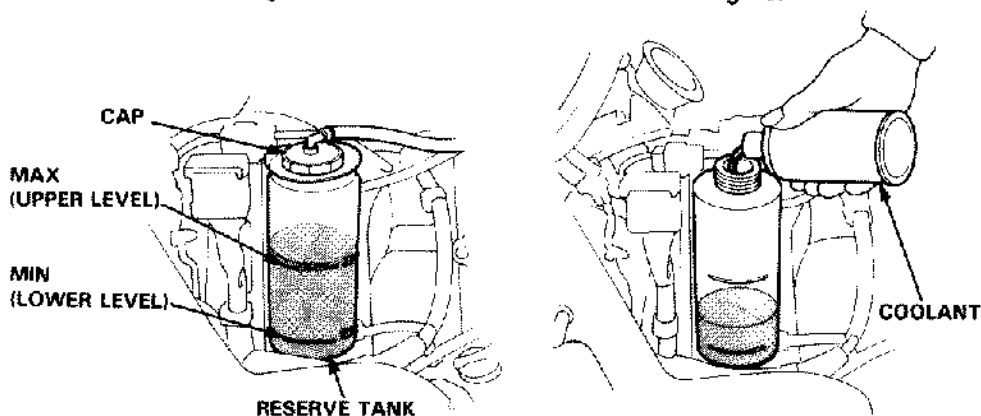

## 5. Check the air cleaner elements

1. Remove the two wing nuts to remove the air cleaner cover.
2. Remove the air cleaner elements.

If the elements are dirty, follow the cleaning procedure described on page 38.

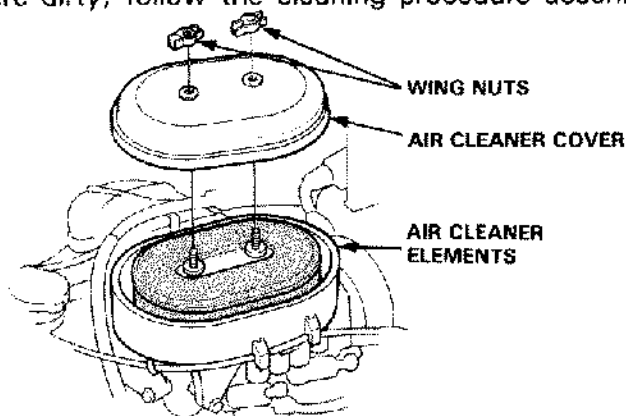

## 6. Check brake lining wear

Inspect brake lining condition every time the lawn tractor is used. Press firmly on the brake pedal with your hand and then check the position of the brake wear indicator. If the indicator is near the wear limit point, take the lawn tractor to an Authorized Honda Power Equipment Dealer for repair.

**CAUTION:** Under no circumstances should the lawn tractor be operated if the brake lining is at the service limit.

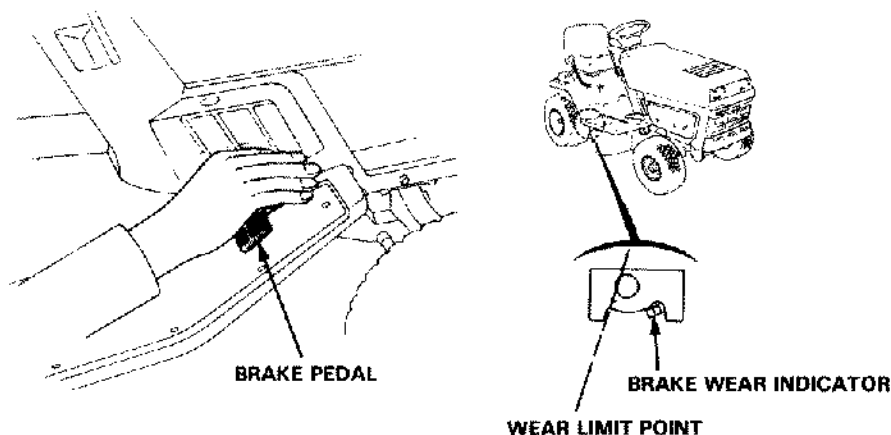

## 7. Check the cutter deck drive belt.

1. Lower the cutter deck by using the cutter deck height adjusting lever, and open the engine hood.
2. Inspect the belt for wear or damage. If worn or damaged, replace the belt as described on page 45.

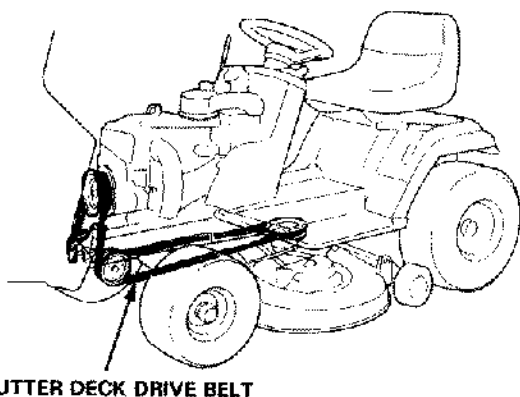
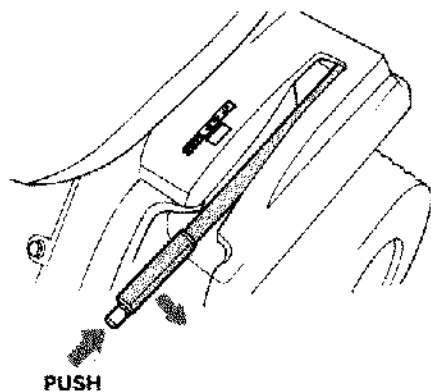

3. Check belt tension at the tensioner arm. The mark on the tensioner arm should align with the tension indicator. If not, turn the adjusting knob to align the mark with the indicator.

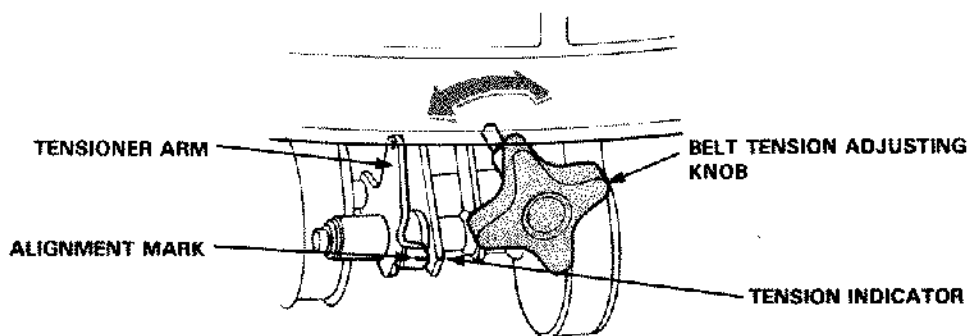

## 8. Check the battery

Open the engine hood and check the battery electrolyte level.

The electrolyte level must be maintained between the upper and lower level lines on the side of the battery.

If the electrolyte level is low, remove the battery filler caps and carefully add distilled water to the upper level line.

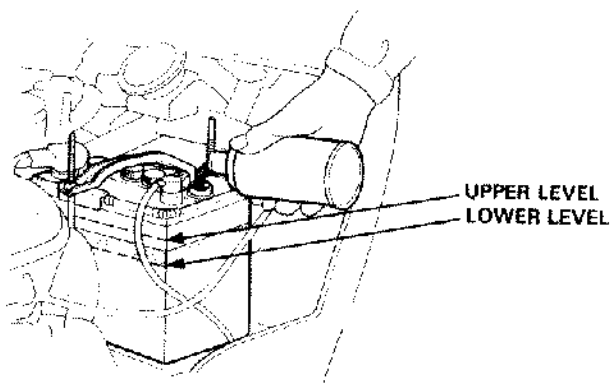

### **WARNING**

- The battery contains sulfuric acid. Avoid contact with skin, eyes or clothing.

Antidote: **EXTERNAL** — Flush with water.

**INTERNAL** — Drink large quantities of water or milk. Follow with milk of magnesia, beaten egg or vegetable oil. Call a physician immediately.

**EYES** — Flush with water and get prompt medical attention.

- Batteries produce explosive gases. Keep sparks, flames and smoking materials away. Always shield the eyes when working near batteries.

### **CAUTION:**

- Use only distilled water in the battery. Tap water will shorten the service life of the battery.
- Do not fill the battery beyond the **UPPER** level. If overfilled, electrolyte may overflow and corrode tractor components. Immediately wash off any spilled electrolyte.

## 9. Adjust the seat position

1. Loosen the four seat mounting bolts.
2. Move the seat to a position that allows you to reach all controls easily and comfortably.
3. Tighten the seat mounting bolts securely.

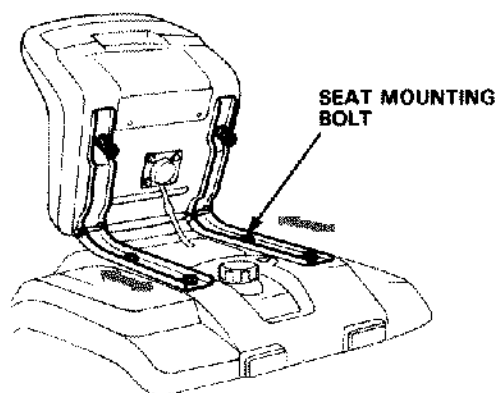

## 10. Check the tire pressure

**CAUTION:** Improper inflation may lead to premature tire failure. Never exceed the manufacturer's maximum tire pressure specification.

Check the tire pressure with an air pressure gauge.

Pressure: Front.... 0.9~1.1 kg/cm<sup>2</sup> (12.8~15.6 psi)

Rear .... 0.6~0.8 kg/cm<sup>2</sup> (8.5~11.4 psi)

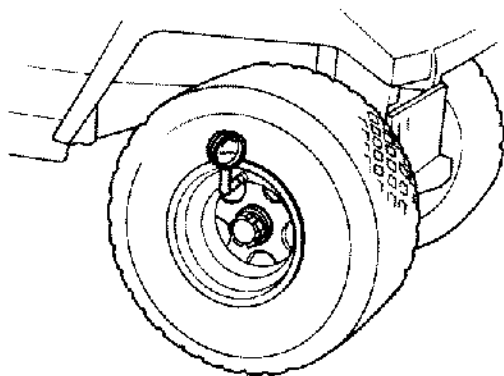

## 6. OPERATION

---

### •High altitude operation

At high altitude, the standard carburetor air-fuel mixture will be excessively rich. Performance will decrease, and fuel consumption will increase.

High altitude performance can be improved by installing a smaller diameter main fuel jet in the carburetor and readjusting the pilot screw. If you always operate the riding mower at altitudes higher than 6,000 feet above sea level, have your authorized Honda Riding Mower dealer perform these carburetor modifications.

Even with suitable carburetor jetting, engine horsepower will decrease approximately 3.5% for each 1,000 foot increase in altitude. The affect of altitude on horsepower will be greater than this if no carburetor modification is made.

**CAUTION:** Operation of the mower at an altitude lower than the carburetor is jetted for may result in reduced performance, overheating, and serious engine damage caused by an excessively lean air/fuel mixture.

### Starting the engine

**WARNING** Exhaust gas contains poisonous carbon monoxide gas. Never run the engine in an enclosed area. Be sure to provide adequate ventilation.

1. Sit on the seat and check that the transmission is in neutral and the P.T.O lever is in the OFF (Disengaged) position.
2. Move the throttle lever to the START (CHOKE) position.

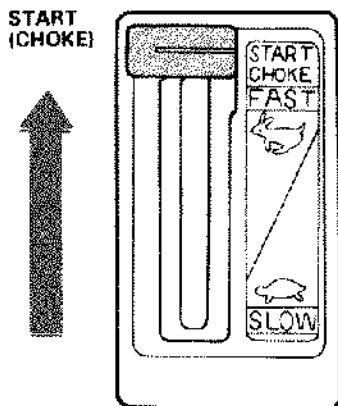

3. Turn the engine switch to START.

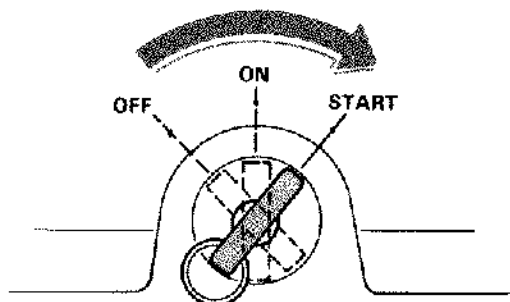

**CAUTION:** Do not use the starter motor for more than 5 seconds. If the engine fails to start, release the key, and wait at least 10 seconds before operating the starter motor again.

4. After the engine starts, let the engine switch return to ON.

5. After the engine warms up, move lever to the SLOW position.

**NOTE:** When the engine is warm or the air temperature is high, move the throttle to SLOW as soon as the engine starts.

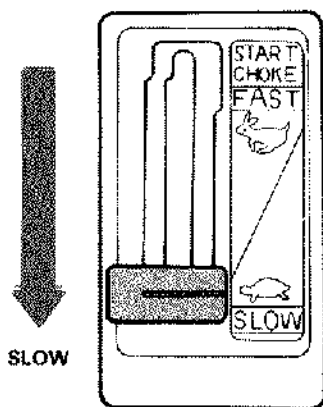



To prevent engine overheating, this lawn tractor is equipped with an OVERHEAT ALERT System. If the overheat alert indicator lamp comes on and the buzzer sounds, stop the engine immediately, and clean the radiator screen thoroughly. (see p. 13)

**WARNING** To prevent accidental start-up, remove the engine switch key before cleaning the radiator screen.

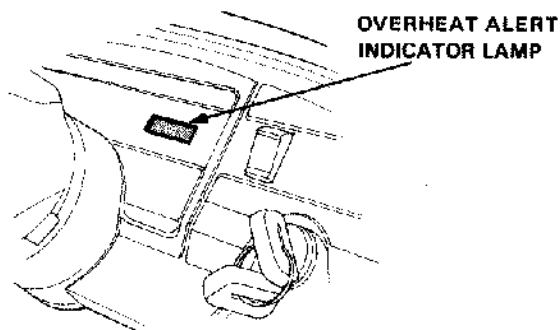

#### 6. Seat safety switch operation check.

1. Move the P.T.O. lever to ON (Engaged).  
Rise off the seat — the engine should stop immediately.
2. Return the P.T.O. lever to OFF (Disengaged) and restart the engine.  
Release the parking brake and place the shift lever in the 1st speed range. While driving slowly, rise off the seat — the engine should stop immediately.

Perform this check on level ground, never on a slope.

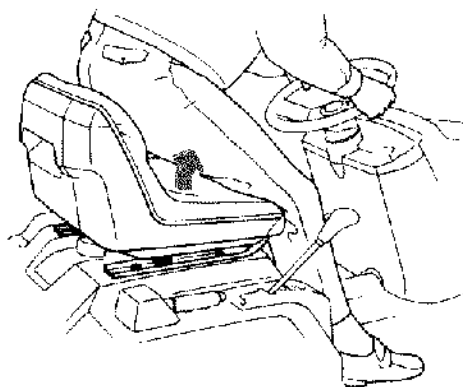

---

## Mowing

**WARNING** Before operating this lawn tractor you should read and understand the safe operating rules. See page 4.

NOTE: For best results, wait until the lawn is dry before mowing.

1. Set the cutter deck height adjusting lever to the desired cutting height.

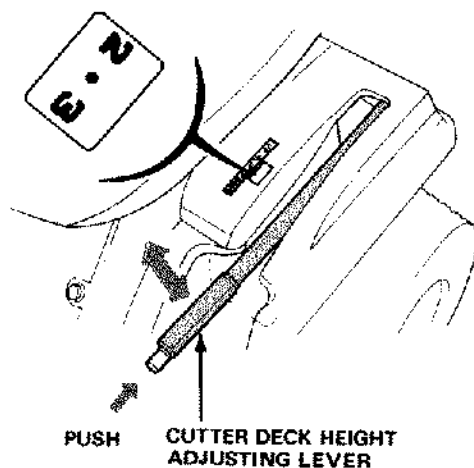

2. Move the throttle lever to the FAST position.

**NOTE:** The tractor can be operated at intermediate throttle settings if desired, but always maintain sufficient engine speed for good pulling power and efficient blade operation. Use the shift lever to select the desired driving speed range.

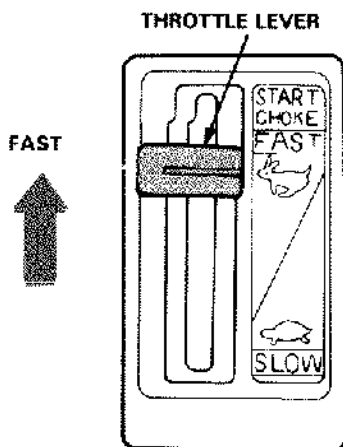

3. Move the P.T.O lever to the ON (Engaged) position.

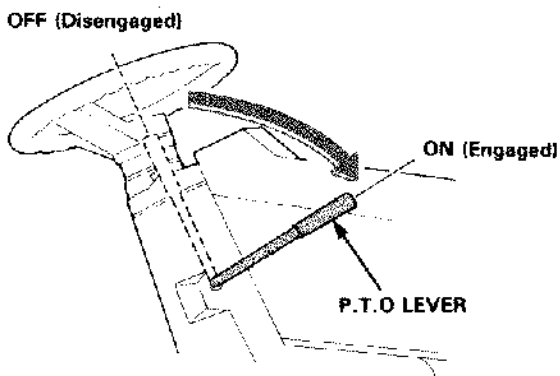

- 
4. Move the shift lever to select the desired gear position. The clutch will engage automatically in about one second.

**CAUTION:** If clutch engagement occurs immediately or takes longer than one second, have the lawn tractor serviced by your HONDA dealer.

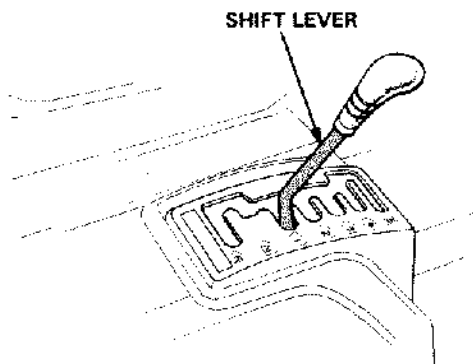

**CAUTION:** If possible, avoid stopping the lawn tractor while driving uphill. However, if it is necessary to stop, follow this special procedure:

#### UPHILL STARTING PROCEDURE

- A. Set parking brake.
- B. Apply pressure to the brake pedal.
- C. Move the throttle lever to mid range.
- D. Shift the transmission to 1st gear position.
- E. Release the brake pedal.
- F. Wait until the clutch engages.
- G. Then release the parking brake lever.

**CAUTION:** If the parking brake lever is released before the brake pedal, the lawn tractor may roll downhill before the clutch engages. This may cause the lawn tractor to tip over.

---

## 5. Cutting Patterns

**WARNING** These cutting patterns are only recommended for a flat, level lawn surface. See safe operating rules page 4.

- To spread grass cuttings evenly, mow the outside perimeter of the lawn in a clockwise direction, and then mow the rest of the lawn counterclockwise.

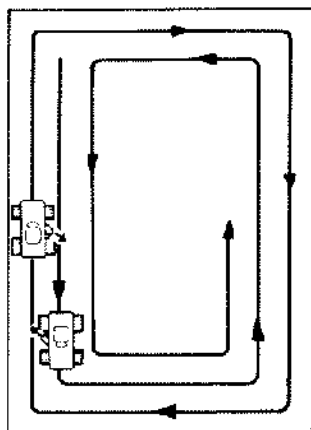

---

## Stopping the Engine

- In an emergency;  
Turn the engine switch OFF.
- In normal use;  
(1) Move the P.T.O lever to OFF (Disengaged).

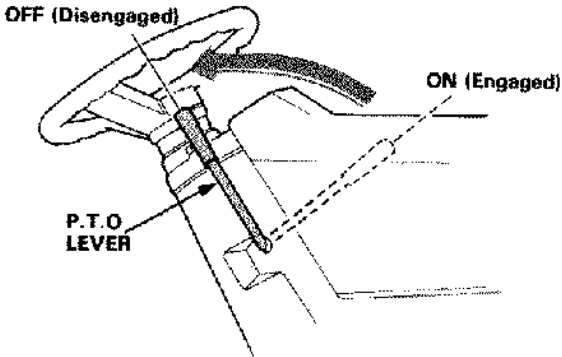

- (2) Move the shift lever to the Neutral position.
- (3) Set the parking brake.
- (4) Turn the engine switch OFF.

**CAUTION** Always remove the key from the engine switch whenever the lawn tractor is unattended to prevent children or unauthorized persons from starting the engine.

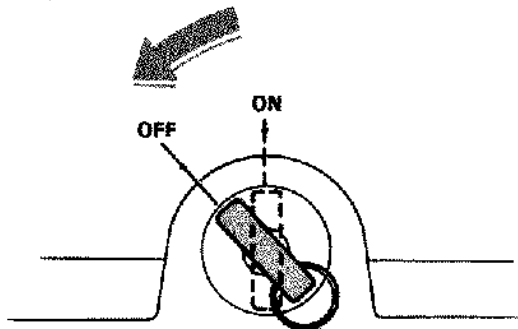

## 7. TRANSPORTING/STORAGE

---

### Transporting

Transport the lawn tractor flat and level.

Set the parking brake lever and tie the tractor down securely, using the tie down points shown below.

**WARNING** Spilled fuel may ignite. To avoid fuel and oil spillage, keep the tractor level when transporting.

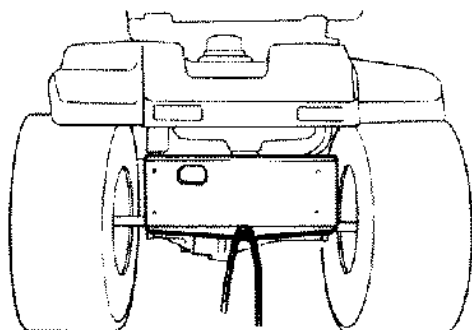
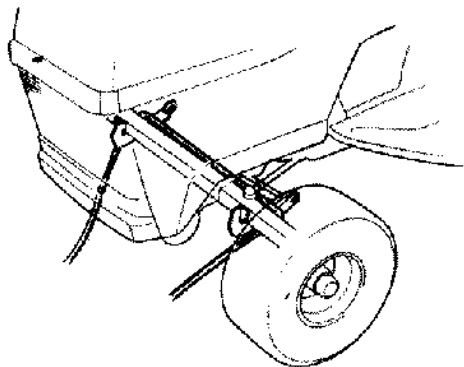

### Preparation for storage.

The following steps should be taken to protect the tractor whenever it will be stored for longer than 30 days.

1. Drain all gasoline from the fuel tank into a suitable gasoline container.

**WARNING** Do not drain the fuel tank when the exhaust system is hot.

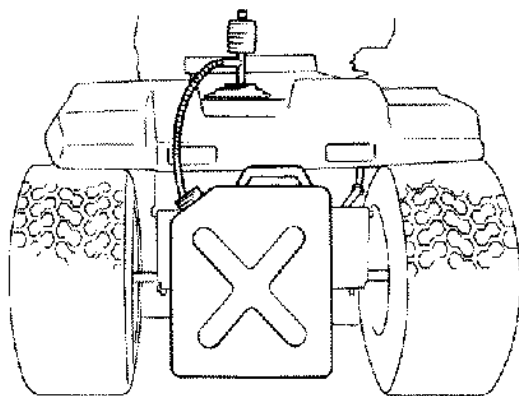

Disconnect the spark plug caps, and turn the engine switch to the ON position to activate the fuel pump.

Loosen the carburetor drain screw, and drain the fuel into a suitable gasoline container.

After draining, turn the engine switch OFF and tighten the drain screw securely.

**CAUTION:** Gasoline is extremely flammable and explosive under certain conditions. Do not smoke or allow flames or sparks in the area.

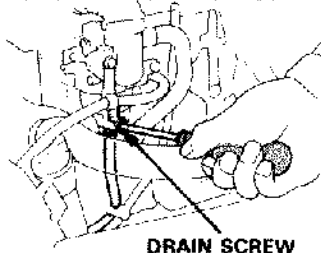

## 2. Change the engine oil (See p.37)

**NOTE:** If the lawn tractor will be stored for longer than 3 months, remove the spark plugs and pour three tablespoons (approximately 1 oz.) of clean motor oil into each cylinder.

Place the PTO (Power Take-off) lever in the ON position. Turn the front clutch several rotations by hand, then return the PTO lever to the OFF position. Reinstall the spark plugs.

**CAUTION:** Be sure to wear hard gloves when turning the front clutch. If the lawn tractor has been running, the engine will be very hot. Allow it to cool before proceeding.

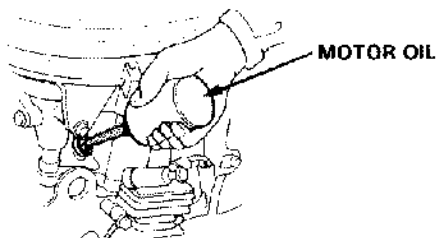



3. Remove the battery and store in a cool, dry place. Recharge it once a month.
4. Lower the cutter deck and loosen the belt tension adjusting knob. Raise the pulley on the tensioner arm side, then remove the belt from the pulleys starting with the one on the opposite side. Remove the belt from the cutter deck driven pulley. Remove the six yellow colored lock pins (three on each side), and remove the cutter deck from the tractor.

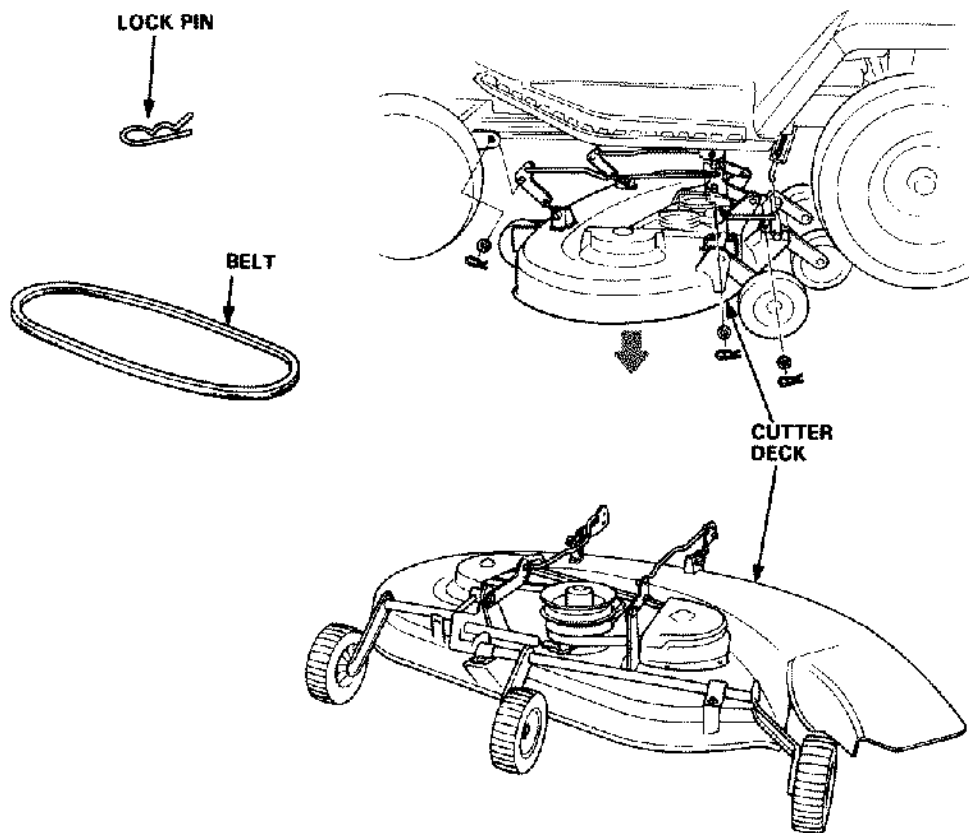

5. Turn the cutter deck upside down. Clean the underside of the deck with water, and dry thoroughly.

---

6. For longer service and greater efficiency, keep the underside of the mower housing clean and free of accumulated grass clippings by washing it down with a hose after use and/or cleaning it with a wire brush and scraper. Remove any rust and apply a rust-resistant paint. Cleaning and rust prevention are especially important before seasonal storage.

7. Reinstall the cutter deck.

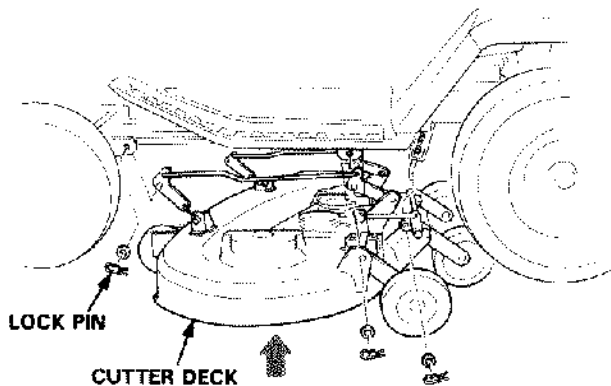

8. Store the tractor on a level surface in a dry, dust-free area with the parking brake lever set.

9. Cover the tractor to keep out dust.

Check tire air pressure regularly during storage and inflate if necessary.

---

## Removal from storage

1. Check the battery electrolyte level (see p. 20). Fully recharge the battery, and install it in the tractor.
2. Remove the spark plugs and check that they are clean and properly gapped (see p.39)  
Turn the engine a few revolutions by hand without the spark plugs.
3. Thread the spark plugs in as far as possible by hand, then tighten them 1/8 to 1/4 turn further with the plug wrench.
4. Check the engine oil level (see p.14).
5. Check the coolant level (see p.17).
6. Fill the fuel tank, and start the engine by following the starting instructions (see p.22).

NOTE: If the cylinders were coated with oil, the engine will smoke at start up; this is normal.



- Shut off the engine and set the parking brake before performing any maintenance.
- To prevent accidental start-up, remove the engine switch key and disconnect the spark plug caps.
- The lawn tractor should be serviced by an authorized HONDA dealer unless the owner has proper tools and service data and feels he is mechanically qualified.

**CAUTION:** Use only genuine Honda parts or their equivalent for maintenance or repair. Replacement parts which are not of equivalent quality may damage the tractor.

Periodic inspection and adjustment of the Honda HT3813 is essential if high level performance is to be maintained. Regular maintenance will also ensure a long service life. The required service intervals and the kind of maintenance to be performed are described on the following page.

ENGINE  
SWITCH  
KEY

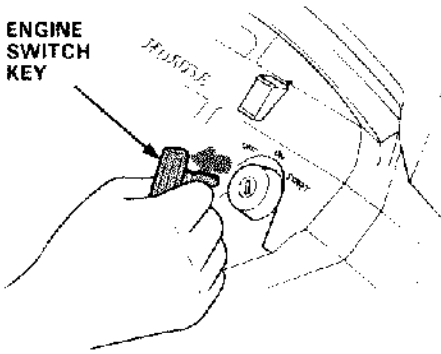

SPARK PLUG CAP

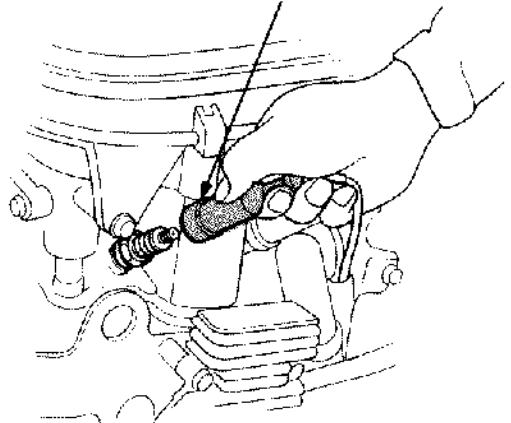

## MAINTENANCE SCHEDULE

REGULAR SERVICE PERIOD		EACH USE	FIRST 3 MONTHS OR 20 HRS (3)	EVERY 6 MONTHS OR 50 HRS (3)	EVERY YEAR OR 100 HRS (3)	EVERY 3 YEARS OR 300 HRS (3)
ITEM	Perform at every indicated month or operating hour interval, whichever comes first.					
Engine oil	Check level	○				
	Change		○		○	
Air cleaner	Check	○				
	Clean			○(1)		
Seat switch operation	Check	○			○(2)	
Radiator screen	Clean	○				
Parking brake indicator lamp and buzzer operation	Check	○		○(2)		
Battery electrolyte	Check level	○				
	Check level and gravity			○(2)		
Tire pressure	Check	○				
Deck belt	Check	○				
Grass bag (optional part)	Clean	○				
Foot brake	Check	○				
Radiator coolant	Check	○				
	Change		Every 2 years ○(2)			
Blade bolt tightness and blade condition	Check		○(2)	○(2)		
	Adjust		○(2)	○(2)		
Shift lever	Check		○(2)	○(2)		
	Adjust			○(2)		
Brake and clutch (fasteners tightness)	Check		○(2)		○(2)	
Parking brake	Check			○(2)		
Spark plug	Clean-Readjust				○(2)	
Spark arrester (optional part)	Clean				○(2)	
Drive clutch	Check				○(2)	
Transmission oil	Check level				○(2)	
Fuel tank	Clean				○(2)	
Fuel filter	Check (Replace if necessary)				○(2)	
P.T.O. cable	Check-Adjust				○(2)	
P.T.O. clutch	Check				○(2)	
Throttle cable	Check-Adjust				○(2)	
Front axle	Grease				○(2)	
Oil filter	Change		Every 2 years or 300 HRS ○(2)			
Fuel line	Check (Replace if necessary)					○(2)
Valve clearance	Check-Readjust					○(2)
Radiator	Clean					○(2)

### NOTE:

- (1) Service the air cleaner more frequently when used in dusty areas.
- (2) These items should be serviced by an authorized Honda dealer, unless the owner has the proper tools and is mechanically proficient. See the Honda Shop Manual.
- (3) For professional commercial use, log hours of operation to determine proper maintenance intervals.

## 1. Engine oil change

**NOTE:** Drain the oil while the engine is still warm to assure rapid and complete draining.

1. Open the engine hood.
2. Remove the oil filler cap and drain plug, and drain the oil into a suitable container.
3. Retighten the drain bolt securely.
4. Refill to the upper level mark on the dipstick with the recommended oil (see p. 14). Tighten the oil filler cap securely.

**OIL CAPACITY:** 1.4ℓ (1.48 US qt)

### **NOTE:**

To remove the drain bolt, turn the steering wheel to the extreme right and remove the bolt from the left side.

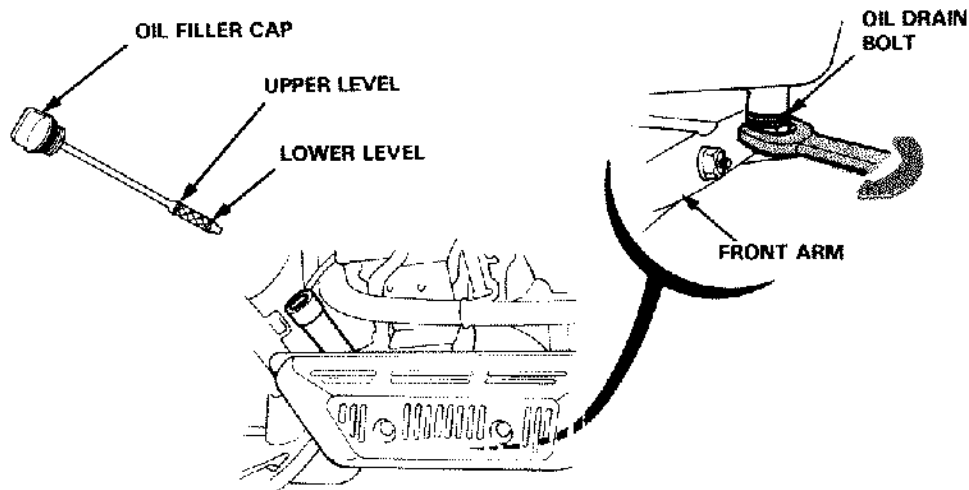

**CAUTION:** Used motor oil may cause skin cancer if repeatedly left in contact with the skin for prolonged periods. Although this is unlikely unless you handle used oil on a daily basis, it is still advisable to thoroughly wash your hands with soap and water as soon as possible after handling used oil.

**NOTE:** Please dispose of used motor oil in a manner that is compatible with the environment. We suggest you take it in a sealed container to your local service station for reclamation. Do not throw it in the trash or pour it on the ground.

## 2. Air cleaner service

A dirty air cleaner will restrict air flow to the carburetor. To prevent carburetor malfunction, service the air cleaner regularly. Service more frequently when operating the tractor in extremely dusty areas.

**WARNING:** Never use gasoline or low flash point solvents for cleaning the air cleaner element. A fire or explosion could result.

**CAUTION:** Never run the engine without the air cleaner. Rapid engine wear will result.

1. Open the engine hood.
2. Remove the wing nuts and the air cleaner cover. Remove the elements and separate them. Carefully check both elements for holes or tears and replace if damaged.
3. Foam element: Clean in warm soapy water, rinse and allow to dry thoroughly. Or clean in high flash-point solvent and allow to dry. Dip the element in clean engine oil and squeeze out all the excess. The engine will smoke during initial start-up if too much oil is left in the foam.
4. Paper element: Tap the element lightly several times on a hard surface to remove excess dirt, or blow compressed air through the filter from the inside out. Never try to brush the dirt off; brushing will force dirt into the fibers.

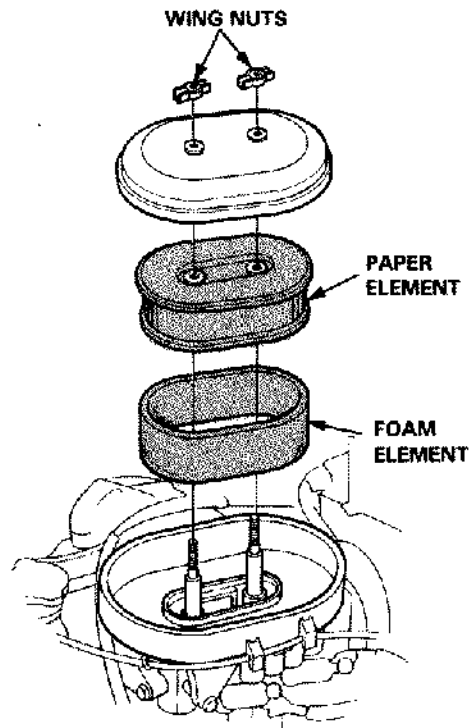

### 3. Spark plug service.

Recommended spark plug: BPR4HS (NGK)

To ensure proper engine operation, the spark plugs must be properly gapped and free of deposits.

1. Open the engine hood and remove the spark plug caps.
2. Clean any dirt from around the spark plug base.
3. Use a spark plug wrench to remove the spark plugs.

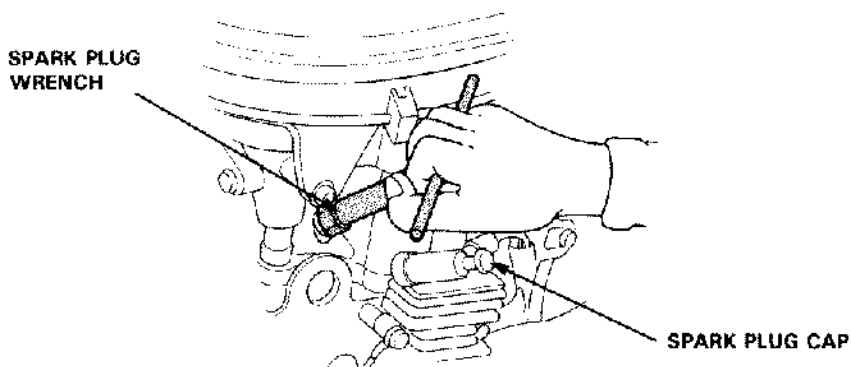

4. Visually inspect the spark plugs. Discard them if the insulator is cracked or chipped. Clean the spark plugs with a wire brush if they are to be reused.
5. Measure the plug gaps with a feeler gauge. The gaps should be 0.6 ~ 0.7 mm (0.024 ~ 0.028 in). Correct as necessary by carefully bending the side electrode.

0.6 ~ 0.7 mm  
(0.024 ~ 0.028 in)

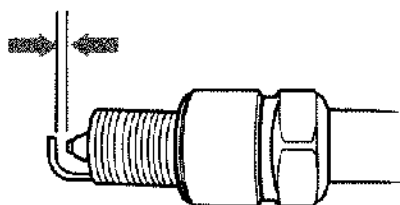



---

6. Thread the plug in by hand to prevent cross threading.

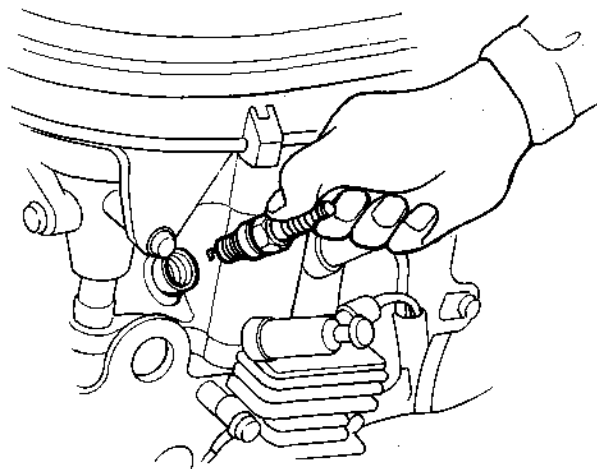

7. After new spark plugs have been seated by hand, they should be tightened  $1/2$  turn with a wrench to compress its washer. If used plugs are being reinstalled, they should only require  $1/8$  to  $1/4$  turn after being seated.

**CAUTION:**

- **The spark plugs must be securely tightened. Improperly tightened plugs can become very hot and possibly damage the engine.**
- **Never use spark plugs with an improper heat range.**

#### 4. Battery electrolyte level check

Open the engine hood and check the electrolyte level in each battery cell. Fill the battery with distilled water to the upper level line. Never overfill the battery. Any corrosion around the positive and negative terminals should be washed off with a solution of baking soda and warm water. Dry the terminals and retighten the terminal bolts if necessary, then coat the terminals with grease.

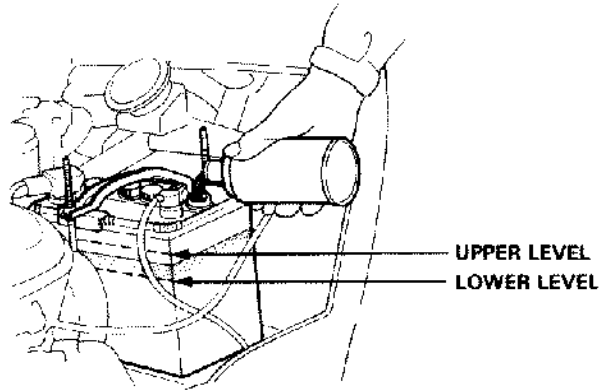

- The battery contains sulfuric acid. Avoid contact with skin, eyes or clothing.

Antidote: **EXTERNAL** — Flush with water.

**INTERNAL** — Drink large quantities of water or milk. Follow with milk of magnesia, beaten egg or vegetable oil. Call a physician immediately.

**EYES** — Flush with water and get prompt medical attention.

- Batteries produce explosive gases. Keep sparks, flames and cigarettes away. Always shield the eyes when working near batteries.

#### CAUTION:

- Use only distilled water in the battery. Tap water will shorten the service life of the battery.
- Do not fill the battery beyond the **UPPER** level. If overfilled, electrolyte may overflow and corrode tractor components. Immediately wash off any spilled electrolyte.

## 5. Fuel filter

Remove the fuel filter by pulling it out of its clip under the fuel tank and visually inspect it through the opening in the hitch plate. Replace the filter if it is contaminated with dirt or water.

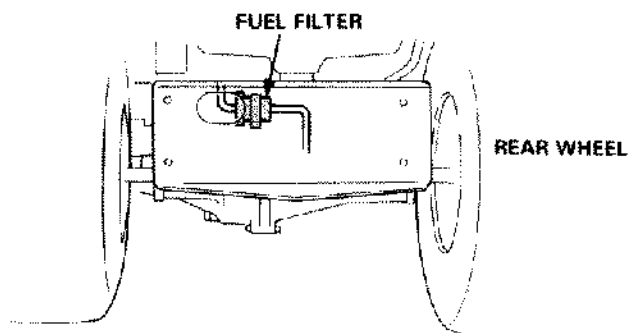

## 6. Drive clutch inspection

1. Place the shift lever in the 2nd gear position.
2. Raise the seat and remove the inspection hole cap.
3. Visually check the position of the indicator mark on the clutch rod; it should be between the two notches on the clutch housing. If the indicator has moved past the red notch on the clutch housing, the clutch disk must be replaced.

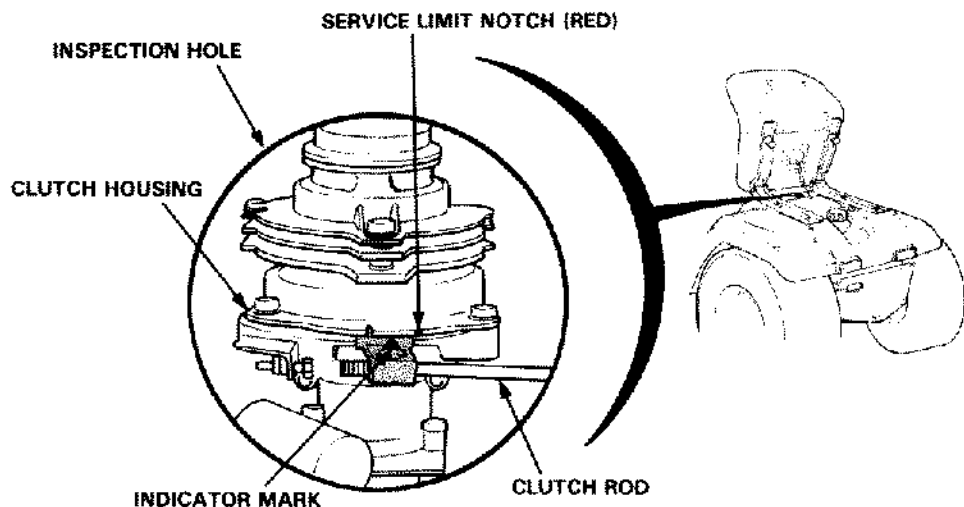

---

## 7. Headlight bulb replacement

Push and twist the bulb connector counterclockwise, then remove the connector and bulb.

When installing the bulb, align the projection on the base of the bulb with the groove in the headlight case.

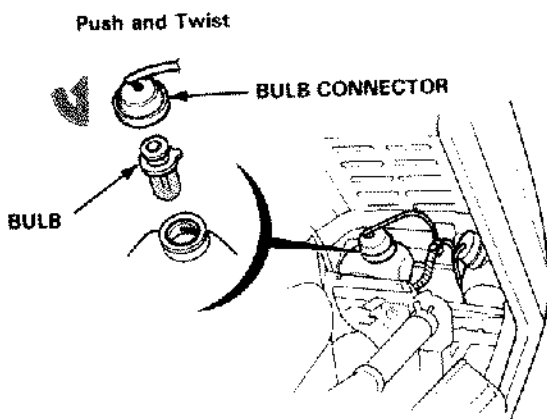

## 8. Wheel removal

### **WARNING**

- Do not attempt to remove a wheel unless the lawn tractor is on firm and level ground.
- Do not attempt to remove or replace a tire unless you have the equipment and knowledge to do so properly.

Block wheels securely.

1. Remove the center cap and cotter pin.
2. Remove the wheel hub nut with a 19 mm socket.
3. Raise the wheel off the floor using a jack and remove the wheel.

Jack points

Front

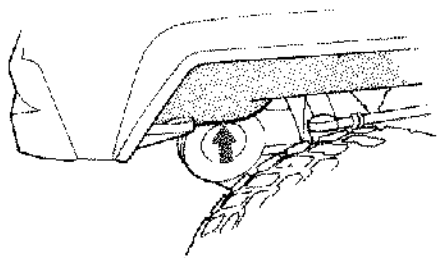

Rear

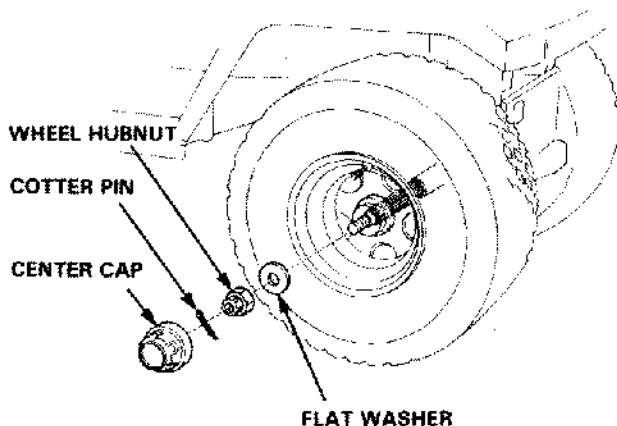
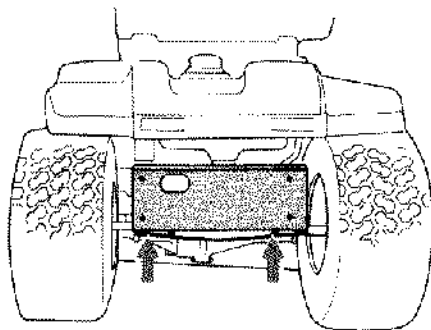

## 9. Cutter deck drive belt replacement

**WARNING** Never attempt to change drive belts while the engine is running. Remove the engine key from the ignition and disconnect the spark plug caps to prevent accidental start up.

### CAUTION:

- Wear heavy gloves to protect your hands when replacing drive belts or when working with cutter blades.
- If the tractor has been running, the engine, muffler and radiator will be very hot. Allow them to cool before proceeding.

1. Lower the cutter deck.
2. Loosen the belt tension adjusting knob, and raise the pulley on the tensioner arm side. Remove the belt from the pulleys starting with the one on the opposite side.
3. Remove the belt from the cutter deck driven pulley.
4. Open the engine hood, and remove the belt stopper by removing the 10 mm flange nut.
5. Release the clips and open the upper radiator shroud.
6. Remove the belt through the top by first lifting the belt up, and then sliding it sideways toward the radiator as shown in Fig. (A).
7. Installation sequence is essentially the reverse order of removal. See Page 19 for belt tension adjustment.

### CAUTION:

- When reinstalling the belt stopper, check that the clearance between the belt stopper and pulley is 3–6 mm (0.1–0.2 in.), then tighten the 10 mm flange nut securely.
- After installing the belt and adjusting the belt tension, start the engine and shift the P.T.O. lever into ON and OFF to be sure that it operates properly.

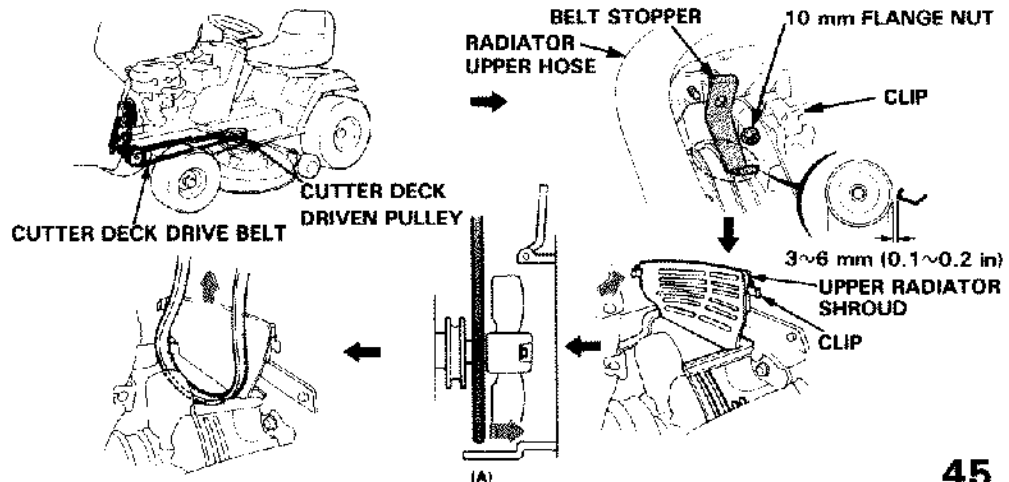

## 10. Blade belt replacement

1. Lower the cutter deck, remove the six yellow colored lock pins (see p.32) and remove the cutter deck.
2. Remove the six 8 mm bolts and remove the pulley covers.
3. Pull the belt off pulley A, hold the belt securely and slowly release the idle pulley.

**CAUTION:** If the belt is not released slowly, the idle pulley will move suddenly and could injure your hand.

4. Remove the belt from the other pulleys, and replace the belt.

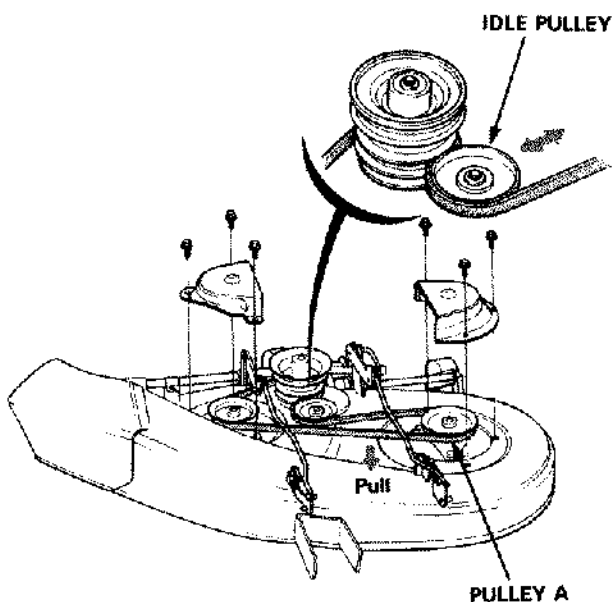

## 11. Blade inspection and sharpening

**CAUTION:** Always wear heavy gloves to protect your hands when working with the cutter blade.

### Blade inspection

1. Remove the cutter deck from the lawn tractor (see p. 32).
2. Inspect the blade for cracks, bends or signs of wear. If either of the blades is bent, damaged or badly worn, replace it.

**CAUTION:** Use only genuine Honda replacement blades or their equivalent.

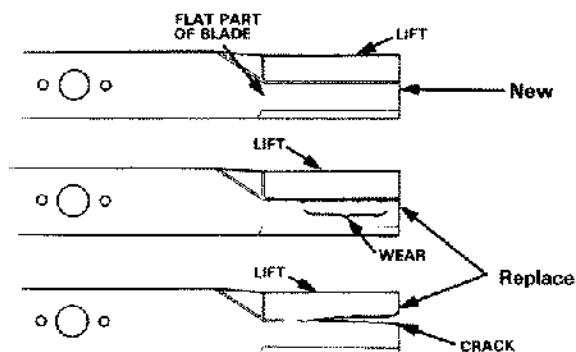

### Blade sharpening

1. Remove the cutter deck (see p.32), and turn it upside down.
2. Remove the blade bolts and the blades.

**CAUTION:** To avoid damaging the blades, be sure to hold them securely while dressing or resharpening them.

3. Maintain the original cutting edge bevel when resharpening or dressing the blades. Leave a 1/64 inch (0.4mm) flat face on the cutting edge; a razorsharp edge will chip easily, and will become dull quickly.

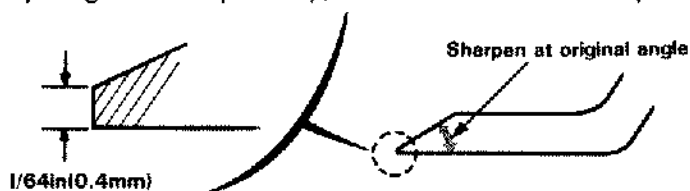



4. When resharpening, do not file the blade parallel to the original edge. Instead, file the blade on an angle as shown, and do not extend the cutting edge any farther toward the center of the blade. Be sure to remove equal amounts of material from each end of the blade to maintain proper balance.

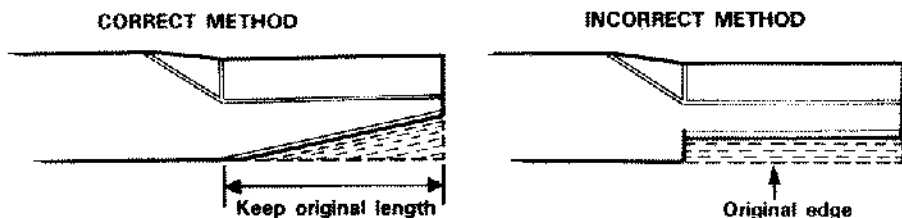

5. After sharpening, test the blade's balance using a screwdriver as shown. If either side dips slightly below horizontal, file that side. Replace the blade if it dips excessively.

**CAUTION:** An unbalanced blade will cause abnormal vibration, and eventual mower damage.

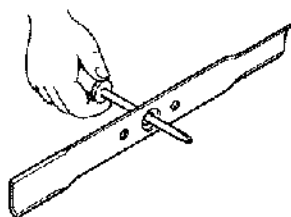

6. Clean any dirt and grass from around the blades shaft and inside the deck.  
7. Install the blades. Tighten the bolts securely and install the mower deck.

**Blade bolt tightening torque: 5.0—6.0 Kg-m (36.2—43.4 ft-lb)**

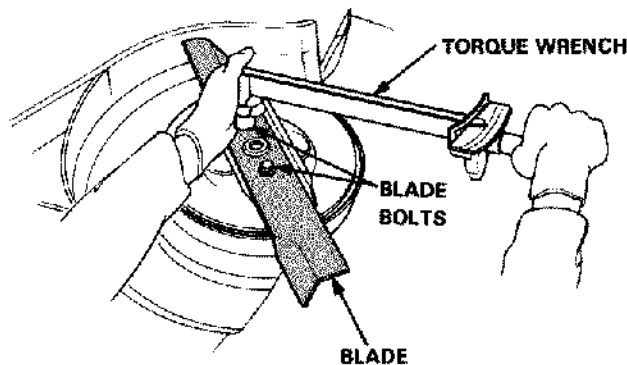

## 12. Shift lever freeplay

Place the shift lever in the 2nd gear position. Measure the distance between the edge of the shift lever and the gear plate, as illustrated below. If the freeplay is less than 4 mm (0.16 in) or more than 11 mm (0.43 in), have the lawn tractor serviced by an authorized Honda Dealer.

**CAUTION:** Transmission or clutch damage may result if the lawn tractor is operated with incorrect shift lever freeplay.

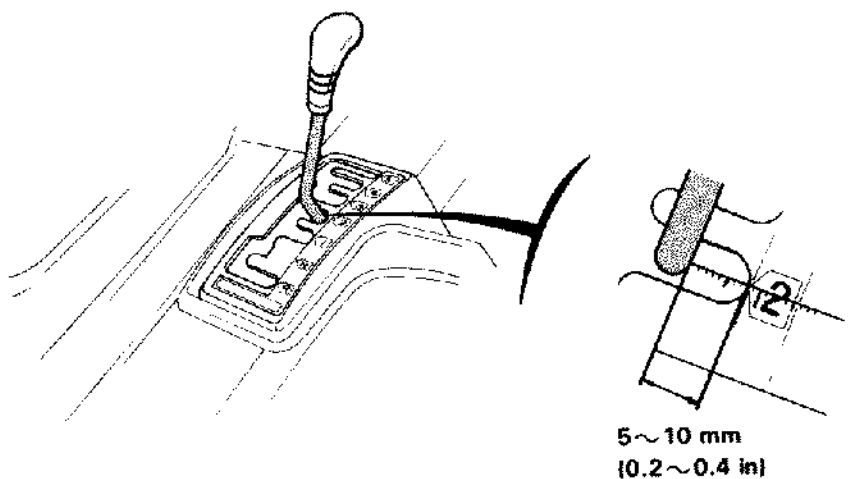

### 13. Spark arrester maintenance (optional part)

**CAUTION:** If the lawn tractor has been running, the muffler will be hot. Allow it to cool before proceeding.

1. Remove the four 6 mm bolts and remove the muffler protector.
2. Remove the two 5 mm screws from the exhaust pipe tip. Remove the exhaust pipe tip and spark arrester (be careful not to damage the spark arrester screen).
3. Use a wire brush to remove carbon deposits from the spark arrester screen.

**NOTE:** Inspect the spark arrester screen for holes or tears. Replace if necessary.

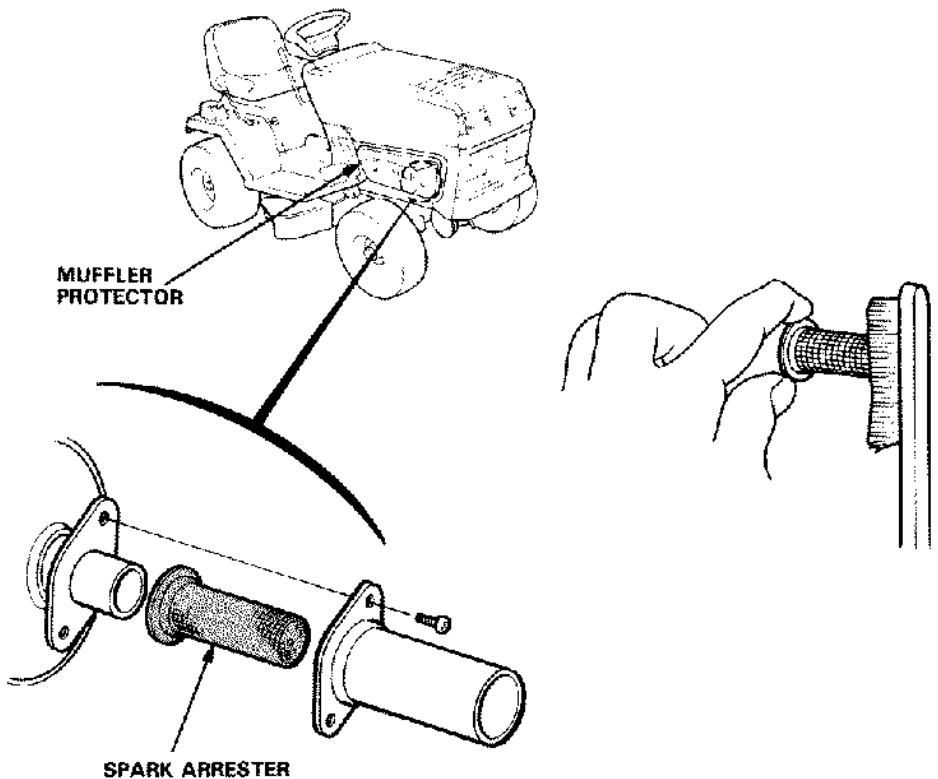

B	BLACK
Y	YELLOW
RD	RED
BLU	BLUE
C	GREEN
W	WHITE
GR	BROWN

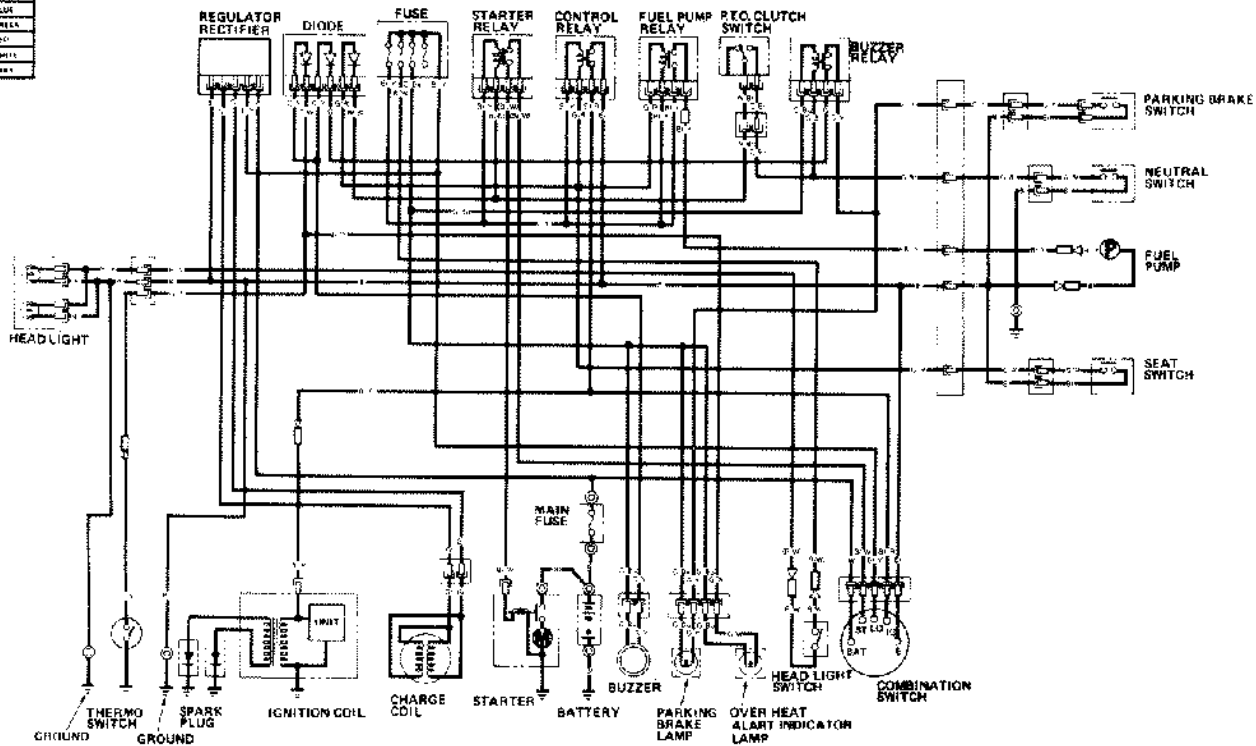

## 10. TROUBLE SHOOTING

---

Engine fails to start;

1. No fuel. —————> Add fuel.
2. Shift lever in gear. —————> Position shift lever in NEUTRAL.
3. P.T.O. lever engaged. —————> Position blade (P.T.O.) lever in DISENGAGE.
4. Spark plug faulty or —————> Regap plug or replace (see p. 39).  
improperly gapped.
5. Spark plug wire loose —————> Check spark plug wire.  
or disconnected.
6. Fuel not reaching —————> See your authorized HONDA dealer.  
carburetor.
7. Discharged battery or —————> Charge battery or retighten terminal.  
loose terminal. (see p. 41).

Engine loses power;

1. Dirty air cleaner elements. —————> Clean or replace elements (see  
p. 38).
2. Spark plug faulty or —————> Regap plug or replace.  
improperly gapped.
3. Engine overloaded. —————> Shift to lower speed.

Engine overheats;

1. Radiator screen plugged. —————> Clean radiator screen (see p. 13).
2. Engine overloaded. —————> Shift to lower speed.
3. Low engine oil level. —————> Fill with recommended oil (see  
p. 14).
4. Spark plug improperly. —————> Regap plug or replace.  
gapped
5. Lack of radiator coolant. —————> Fill with recommended coolant  
(see p. 17).

---

Erratic operation;

1. Dirty fuel. —————> See your HONDA dealer.
2. Dirty air cleaner elements. —————> Clean air cleaner elements.
3. Spark plug faulty or —————> Regap plug or replace.  
improperly gapped.

Excessive vibration;

1. Loose blade or engine —————> Retighten blade bolts or engine  
mounting hardware. mounting hardware.
2. Damaged blade or out of —————> Replace blade.  
balance.

Battery will not charge;

1. Dead cell in battery. —————> Replace battery
2. Loose electrical connec- —————> Check connections and lines.  
tions or broken wire.

Uneven mowing;

1. Tractor speed too fast. —————> Shift to lower speed.
2. Grass accumulation —————> Clean deck inside (see p. 32).  
inside deck.
3. Dull blade. —————> Sharpen blade or replace.
4. Tires improperly inflated. —————> Check tire inflation (see p. 21).
5. Mower not level. —————> Check cutter deck mounting.
6. Wrong cutter deck height. —————> Change to proper height.
7. Discharge fan damage. —————> See your authorized HONDA dealer.
8. Chute clogged (if equipped —————> Empty grass bag and chute.  
with optional grass bag).

---

Clogged cutter deck discharge chute.

1. Wrong blade. —————> Use genuine Honda blade or equivalent.
2. Deck too low. —————> Raise deck and adjust deck height properly.
3. Engine overloaded. —————> Operate at full throttle. Use lower speed range. Set cutter deck higher than desired height for first pass, then cut to desired height on second pass.
4. Grass bags full —————> Empty grass bags.  
(Optional part).

Blades do not rotate or stop.

1. Blade drive belt worn or broken. —————> Replace with new belt (see p. 46).
2. P.T.O. lever cable cut or out of adjustment. —————> See your authorized HONDA dealer.
3. Faulty P.T.O. clutch assy or worn disk. —————> See your authorized HONDA dealer.

Tractor does not move, or clutch does not engage properly when the transmission is shifted into gear.

1. Faulty clutch assy. —————> See your authorized HONDA dealer.
2. Transmission does not shift gear. —————> See your authorized HONDA dealer.
3. Abnormal clutch engagement. —————> See your authorized HONDA dealer.

## 11. SPECIFICATIONS

MODEL	HT3813
<b>ENGINE</b>	
Model	GX360K1
Type	OHC Twin cylinder
Displacement	359 cm <sup>3</sup> (21.9 cu in)
Bore and stroke	58 × 68 mm (2.28 × 2.68 in)
Ignition timing	24° BTDC
Ignition system	Transistorized magneto
Cooling system	Liquid cooled
Coolant	1.75ℓ (1.85 US qt)
Engine oil capacity	1.4ℓ (1.48 US qt)
Spark plug	BPR4HS (NGK)
<b>FRAME</b>	
Dimensions	
Length x Width x Height	1755 x 1260 x 1045 mm (69.1 x 49.6 x 41.1 in)
Wheel tread	
Front	710 mm (28.0 in)
Rear	680 mm (26.8 in)
Wheel base	1160 mm (45.7 in)
Cutting width	965 mm (38.0 in)
Cutting height	1-1/2, 2, 2-1/2, 3, 3-1/2, 4 in
Dry weight	252 kg (555 lb)
Tire size	Front 15 × 6.00 – 6, Rear 18 × 8.50 – 8
Air pressure	Front 1.0 kg/cm <sup>2</sup> , Rear 0.7 kg/cm <sup>2</sup>
Gear selections	5 Forward, 1 Reverse
Travel speed (3300 rpm)	
First	1.8 km/h (1.1 mile/h)
Second	2.3 km/h (1.4 mile/h)
Third	3.3 km/h (2.1 mile/h)
Fourth	5.1 km/h (3.2 mile/h)
Fifth	8.6 km/h (5.4 mile/h)
Reverse	2.9 km/h (1.8 mile/h)
Fuel tank capacity	7.1ℓ (1.88 US gal)
Battery	Std 12V30A. Opt 12V35A

NOTE: Specifications are subject to change without notice.



## 12. WARRANTY SERVICE

---

### Owner Satisfaction

Your satisfaction and goodwill are important to your dealer and to us. All Honda warranty details are explained in the Distributor's Limited Warranty. Normally, any problems concerning the product will be handled by your dealer's service department. If you have a warranty problem that has not been handled to your satisfaction, we suggest you take the following action:

- Discuss your problem with a member of dealership management. Often complaints can be quickly resolved at that level. If the problem has already been reviewed with the Service Manager, contact the owner of the dealership or the General Manager.
- If your problem still has not been resolved to your satisfaction, contact the Power Equipment Customer Relations Department of American Honda Motor Co., Inc.

American Honda Motor Co., Inc.  
Power Equipment Customer Relations Department  
P.O. Box 50  
Gardena, California 90247-0805  
Telephone: (213) 604-2400

We will need the following information in order to assist you:

- Your name, address, and telephone number
- Product model and serial number
- Date of purchase
- Dealer name and address
- Nature of the problem

After reviewing all the facts involved, you will be advised of what action can be taken. Please bear in mind that your problem will likely be resolved at the dealership, using the dealer's facilities, equipment, and personnel, so it is very important that your initial contact be with the dealer.

Your purchase of a Honda product is greatly appreciated by both your dealer and American Honda Motor Co., Inc. We want to assist you in every way possible to assure your complete satisfaction with your purchase.

## **Current customer service contact information:**

### **United States, Puerto Rico, and U.S. Virgin Islands:**

Honda Power Equipment dealership personnel are trained professionals. They should be able to answer any question you may have. If you encounter a problem that your dealer does not solve to your satisfaction, please discuss it with the dealership's management. The Service Manager or General Manager can help. Almost all problems are solved in this way.

If you are dissatisfied with the decision made by the dealership's management, contact the Honda Power Equipment Customer Relations Office. You can write:

American Honda Motor Co., Inc.  
Power Equipment Division  
Customer Relations Office  
4900 Marconi Drive  
Alpharetta, GA 30005-8847

Or telephone: (770) 497-6400 M-F, 8:30 am - 7:00 pm EST

When you write or call, please provide the following information:

- Model and serial numbers
- Name of the dealer who sold the Honda power equipment to you
- Name and address of the dealer who services your equipment
- Date of purchase
- Your name, address, and telephone number
- A detailed description of the problem

---

**MEMO**

---

**MEMO**

---

**MEMO**

---

**MEMO**



**HONDA**  
HONDA MOTOR CO., LTD. TOKYO, JAPAN

31750602  
00X31-750-6020



Ⓜ Ⓜ 5008612  
PRINTED IN JAPAN

## Free Manuals Download Website

<http://myh66.com>

<http://usermanuals.us>

<http://www.somanuals.com>

<http://www.4manuals.cc>

<http://www.manual-lib.com>

<http://www.404manual.com>

<http://www.luxmanual.com>

<http://aubethermostatmanual.com>

Golf course search by state

<http://golfingnear.com>

Email search by domain

<http://emailbydomain.com>

Auto manuals search

<http://auto.somanuals.com>

TV manuals search

<http://tv.somanuals.com>