

OPERATING AND SERVICE MANUAL

hp-1465B

MULTIMETER

3465B

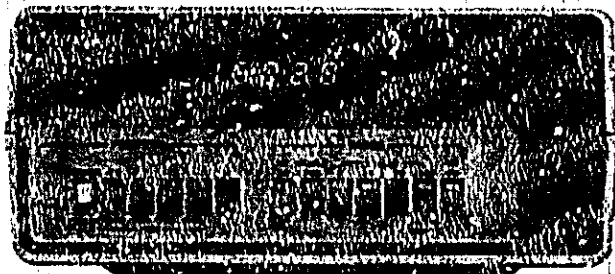

HEWLETT  PACKARD

hp-3465B



OPERATING AND SERVICE MANUAL

MODEL 3465B

MULTIMETER

Serial Numbers: 1530A02649 and greater

IMPORTANT NOTICE

Any changes made in instruments manufactured after this printing will be found in a "Manual Changes" supplement supplied with this manual. Be sure to examine this supplement, if one exists for this manual, for any changes which apply to your instrument and record these changes in the manual.

If the Serial Number of your instrument is lower than the one on this title page, the manual contains revisions that do not apply to your instrument. Backdating information given in the manual adopts it to earlier instruments.

Where practical, backdating information is integrated into the text, parts list and schematic diagrams. Backdating changes are denoted by a delta sign. An open delta (Δ) or lettered delta (ΔA) on a given page refers to the corresponding backdating note on that page. Backdating changes not integrated into the manual are denoted by a numbered delta ($\Delta 1$) which refers to the corresponding change in the Backdating Section (Section VIII).



This symbol is an International symbol meaning "refer to the Operating and Service Manual." The symbol flags important operating instructions in Section III.

WARNING

To prevent potential fire or shock hazard, do not expose equipment to rain or moisture.

Manual Part No. 03465-90012

Microfiche Part No. 03465-90062

Copyright Hewlett-Packard Company 1976
P.O. Box 301, Loveland, Colorado 80537 U.S.A.



SAFETY

This product has been designed and tested according to International Safety Requirements. To ensure safe operation and to keep the product safe, the information, cautions, and warnings in this manual must be heeded. Refer to Section I for general safety considerations applicable to this product.

CERTIFICATION

Hewlett-Packard Company certifies that this product met its published specifications at the time of shipment from the factory. Hewlett-Packard further certifies that its calibration measurements are traceable to the United States National Bureau of Standards, to the extent allowed by the Bureau's calibration facility, and to the calibration facilities of other International Standards Organization members.

WARRANTY

This Hewlett-Packard product is warranted against defects in material and workmanship for a period of one year from date of shipment, except that in the case of certain components listed in Section I of this manual, the warranty shall be for the specified period. During the warranty period, Hewlett-Packard Company will, at its option, either repair or replace products which prove to be defective.

For warranty service or repair, this product must be returned to a service facility designated by -hp-. However, warranty service for products installed by -hp- and certain other products designated by -hp- will be performed at Buyer's facility at no charge within the -hp- service travel area. Outside -hp- service travel areas, warranty service will be performed at Buyer's facility only upon -hp-'s- prior agreement and Buyer shall pay -hp-'s- round trip travel expenses.

For products returned to -hp- for warranty service, Buyer shall prepay shipping charges to -hp- and -hp- shall pay shipping charges to return the product to Buyer. However, Buyer shall pay all shipping charges, duties, and taxes for products returned to -hp- from another country.

LIMITATION OF WARRANTY

The foregoing warranty shall not apply to defects resulting from improper or inadequate maintenance by Buyer, Buyer-supplied software or interfacing, unauthorized modification or misuse, operation outside of the environmental specifications for the product, or improper site preparation or maintenance.

NO OTHER WARRANTY IS EXPRESSED OR IMPLIED. HEWLETT-PACKARD SPECIFICALLY DISCLAIMS THE IMPLIED WARRANTIES OF MERCHANTABILITY AND FITNESS FOR A PARTICULAR PURPOSE.

EXCLUSIVE REMEDIES

THE REMEDIES PROVIDED HEREIN ARE BUYER'S SOLE AND EXCLUSIVE REMEDIES. HEWLETT-PACKARD SHALL NOT BE LIABLE FOR ANY DIRECT, INDIRECT, SPECIAL, INCIDENTAL, OR CONSEQUENTIAL DAMAGES, WHETHER BASED ON CONTRACT, TORT, OR ANY OTHER LEGAL THEORY.

ASSISTANCE

Product maintenance agreements and other customer assistance agreements are available for Hewlett-Packard products.

For any assistance, contact your nearest Hewlett-Packard Sales and Service Office. Addresses are provided at the back of this manual.

TABLE OF CONTENTS

Section	Page
I. GENERAL INFORMATION	1-1
1-1. Introduction	1-1
1-3. Description	1-1
1-5. Specifications	1-1
1-7. Instrument and Manual Identification	1-1
1-9. Options	1-1
1-11. Warranty Exceptions	1-1
1-13. Accessories	1-1
1-15. Safety Considerations	1-1

Section	Page
II. INSTALLATION	2-1
2-1. Introduction	2-1
2-3. Initial Inspection	2-1
2-5. Power Requirements	2-1
2-7. Grounding Requirements	2-1
2-10. Environmental Requirements	2-1
2-12. Repackaging for Shipment	2-1
2-16. Power Cords and Receptacles	2-1

Section	Page
III. OPERATING INSTRUCTIONS	3-1
3-1. Introduction	3-1
3-3. Front Panel Features	3-1
3-5. Turn-on and Warm-up	3-1
3-7. Internal Battery Voltage Measurement and Recharging	3-1
3-9. Low Battery Voltage Detection	3-1
3-11. Overload Indication	3-1
3-13. AC Voltage Measurements	3-1
3-14. AC Voltage Ranges	3-1
3-16. DC Voltage Measurements	3-2
3-17. 20 mV Range Zero Adjust	3-2
3-19. DC Voltage Ranges	3-2
3-21. Current Measurements	3-3/3-4
3-23. AC Current Ranges	3-3/3-4
3-25. DC Current Ranges	3-3/3-4
3-27. Ohms Measurements	3-3/3-4
3-28. Ohmmeter Ranges	3-3/3-4
3-30. Ohmmeter Reference Current	3-3/3-4

Section	Page
IV. THEORY OF OPERATION	4-1
4-1. Introduction	4-1
4-3. Description	4-1
4-6. Simplified Theory	4-2
4-8. Signal Conditioning	4-2
4-18. Analog-to-Digital (A-D) Converter	4-3
4-26. Logic Section	4-4
4-35. Display	4-4
4-37. Power Supply	4-5
4-39. Detailed Theory	4-5
4-41. Precision Resistor Pack (R75)	4-5

Section	Page
4-43. Ohms Converter	4-5
4-50. AC-to-DC Converter	4-6
4-56. A-D Conversion Using a Monopolar Reference	4-6
4-64. Data Accumulator	4-8
4-69. Display	4-8
4-72. Power Supply	4-10
4-77. +10 V series Voltage Regulation	4-11
4-79. Battery Low-Voltage Detection	4-11

Section	Page
V. MAINTENANCE	5-1
5-1. Introduction	5-1
5-3. Test Equipment Required	5-1
5-5. Performance Tests	5-1
5-6. DC Voltmeter Accuracy Test	5-1
5-8. DC Ammeter Accuracy Test	5-1
5-10. Ohms Accuracy Test	5-2
5-12. AC Voltage Accuracy Test	5-2
5-14. AC Ammeter Accuracy Test	5-2
5-16. Alternate AC Ammeter Accuracy Test (200 mA/2000 mA, 40 Hz to 1 kHz)	5-4
5-19. AC Normal Mode Rejection Test	5-5
5-21. AC Effective Common-Mode Rejection Test	5-6
5-23. DC Voltmeter Input Resistance Test	5-6
5-25. AC Voltmeter Input Impedance Test	5-6
5-27. Adjustment Procedures	5-8
5-29. Disassembly Procedure	5-8
5-30. Power Supply Adjustment	5-9
5-34. Input Amplifier Adjustments	5-9
5-37. Ohms Converter Adjustments (R58 and P69)	5-10
5-39. AC-DC Converter Adjustments	5-10

Section	Page
VI. REPLACEABLE PARTS	6-1
6-1. Introduction	6-1
6-4. Ordering Information	6-1
6-6. Non-Listed Parts	6-1
6-8. Parts Changes	6-1
6-10. Proprietary Parts	6-1

Section	Page
VII. TROUBLESHOOTING AND CIRCUIT DIAGRAMS	7-1
7-1. Introduction	7-1
7-3. Schematic Diagrams	7-1
7-5. Preliminary Check	7-1
7-6. Visual Inspection	7-1
7-8. Preliminary Troubleshooting	7-1
7-11. Analog/Digital Isolation	7-1

Section	Page	Section	Page
7-13. Analog Troubleshooting	7-1	7-35. Display and Display Driver Quick Test . .	7-4
7-14. Analog Isolation	7-1	7-37. Display and Display Driver Verification and Troubleshooting Test	7-5
7-18. Power Supply Faults	7-2	7-40. Polarity, Zero Detect and Clock Circuit Verification	7-5
7-20. Signal Conditioning Faults	7-3	7-42. Analog Switch Lines and Control State Counter Verification	7-5
7-26. Analog-to-Digital Converter Faults	7-3	7-44. Data Accumulator Input/Output Verification	7-5
7-29. Integrator/Slope Amplifier/ Comparator/Auto-Zero	7-3		
7-31. Digital Troubleshooting	7-4		
7-33. Display and Display Driver Verification . .	7-4		

LIST OF TABLES

Table	Page	Table	Page
1-1. Specifications	1-2	5-6. AC Ammeter Accuracy Test (200 μ A Through 20 mA).	5-4
1-2. General Information	1-3/1-4	5-7. AC Ammeter Accuracy Test, 200 mA and 2000 mA Ranges.	5-5
3-1. Ohmmeter Current Through Unknown	3-3/3-4	5-8. Alternate AC Ammeter Accuracy Test 200 mA and 2000 mA Ranges.	5-5
4-1. Display Interface Connections	4-9	5-9. Power Supply Jumpers	5-10
5-1. Test Equipment Required	5-0	6-1. Standard Abbreviations	6-1
5-2. DC Voltmeter Accuracy Test	5-1	6-2. Code List of Manufacturers	6-2
5-3. DC Ammeter Accuracy Test	5-2	6-3. Replaceable Parts	6-3
5-4. Ohms Accuracy Test	5-2		
5-5. AC Voltage Accuracy Test	5-3		

LIST OF ILLUSTRATIONS

Figure	Page	Figure	Page
2-1. Power Receptacles	2-2	4-10. Simplified Diagram, DC-to-DC Converter	4-10
3-1. Front Panel Features	3-2	4-11. Common-Emitter Output Characteristics	4-11
4-1. Basic Block Diagram and Measurement Sequence	4-1	5-1. DC Ammeter Accuracy Test	5-1
4-2. Simplified Diagram, Ohms Converter	4-2	5-2. Ohms Accuracy Test	5-2
4-3. Block Diagram, AC-to-DC Converter	4-3	5-3. AC Ammeter Accuracy Test 200 μ A through 20 mA Range	5-3
4-4. Block Diagram, Power Supply	4-5	5-4. AC Ammeter Accuracy Test 200 mA and 2000 mA	5-5
4-5. Over-Voltage Protection Circuit	4-5	5-5. AC Normal-Mode Rejection Test	5-6
4-6. Basic Diagram, AC Converter Amplifier	4-6	5-6. AC Effective Common-Mode Rejection Test	5-6
4-7. Functional Diagram, A-D Converter	4-7	5-7. DC Voltmeter Input Resistance Test	5-7
4-8. Data Accumulator	4-9	5-8. AC Voltmeter Input Impedance Test	5-7
4-9. Basic Diagram, DC-to-DC Converter	4-10	5-9. Multimeter Adjustment Location	5-8

SECTION I

GENERAL INFORMATION

1-1. INTRODUCTION.

1-2. This section contains general information concerning the -hp- Model 3465B Multimeter. Included is an instrument description, specifications, information about instrument and manual identification, option and accessory information and safety considerations.

1-3. DESCRIPTION.

1-4. The -hp- Model 3465B Multimeter is a 4-1/2 digit, five function digital multimeter. The five functions are dc volts, ac volts, dc current, ac current and ohms. Measurements can be made to four significant digits with a sample rate of 2-1/2 readings per second. Throughout this manual, the 3465B Multimeter will be referred to as Multimeter.

1-5. SPECIFICATIONS.

1-6. Instrument specifications are listed in Table 1-1. These specifications are the performance standards or limits against which the instrument is tested. Any change in the specifications due to manufacturing, design or traceability to the U.S. National Bureau of Standards will be covered by a change sheet. Additional information describing the operating characteristics are not specifications but are supplemental information for the user.

1-7. INSTRUMENT AND MANUAL IDENTIFICATION.

1-8. Hewlett-Packard uses a two-section serial number. The first section (prefix) identifies a series of instruments. The last section (suffix) identifies a particular instrument within the series. If a letter is included with the serial number, it identifies the country where the instrument was manufactured. This manual is kept up-to-date with the instrument at all times by revision. If the serial prefix of your instrument differs from the one on the title page of this manual, refer to Section VIII for backdating information that will adapt this manual to your instrument. All correspondence with Hewlett-Packard should include the complete serial number.

1-9. OPTIONS.

1-10. The following is a list of the options available for the multimeter. Multimeter options are available to allow operation from various line voltages.

Option	Description
100	86 - 106 V ac 48 - 440 Hz
115	104 - 127 V ac 48 - 440 Hz
210	190 - 233 V ac 48 - 440 Hz
230	208 - 250 V ac 48 - 440 Hz
910	An additional Operating and Service Manual

1-11. Warranty Exceptions.

1-12. Batteries are warranted for 90 days.

1-13. ACCESSORIES.

1-14. The following accessories are available to extend the usefulness of your Multimeter:

- a. Model 11096B RF Probe, 100 kHz to 500 MHz (down 3 dB at 10 kHz and 700 MHz), for use on the 10 V and 100 V ranges in the DCV function only.
- b. Model 11002A Test leads, dual banana to dual alligator.
- c. Model 11003A test leads, dual banana to probe and alligator.
- d. Model 11004A dual banana to dual banana, 44 in.
- e. Model 34110A soft vinyl carrying case.
- f. Model 34111A HV Probe, 40 kV dc.
- g. Model 34112A Touch - Hold Input Probe.

1-15. SAFETY CONSIDERATIONS.



1-16. This operating and service manual contains cautions and warnings alerting the user to hazardous operating and maintenance conditions. This information is flagged by a caution or warning heading and/or the symbol . The  symbol appears on the front panel and is an international symbol meaning "refer to the Operating and Service Manual". This symbol flags important operating instructions located in Section III. To ensure the safety of the operating and maintenance personnel and retain the operating condition of the instrument, these instructions must be adhered to.

Table 1-1. Specifications.

DC VOLTMETER		Voltage Burden:																	
Ranges: 20 mV, 200 mV, 2 V, 20 V, 200 V, 1,000 V Maximum Input: 1,000 V (DC + Peak AC) Accuracy (1 year + 23°C ± 5°C):		<table border="1"> <thead> <tr> <th>Range</th> <th>Max Burden at Full Scale</th> </tr> </thead> <tbody> <tr> <td>200 μA – 200 mA</td> <td>< 250 mV</td> </tr> <tr> <td>2,000 mA</td> <td>< 700 mV</td> </tr> </tbody> </table>		Range	Max Burden at Full Scale	200 μA – 200 mA	< 250 mV	2,000 mA	< 700 mV										
Range	Max Burden at Full Scale																		
200 μA – 200 mA	< 250 mV																		
2,000 mA	< 700 mV																		
<table border="1"> <thead> <tr> <th>Range</th> <th>Specification</th> </tr> </thead> <tbody> <tr> <td>20 mV</td> <td>± (0.03% of reading + 2 counts)</td> </tr> <tr> <td>200 mV through 200 V</td> <td>± (0.02% of reading + 1 count)</td> </tr> <tr> <td>1000 V</td> <td>± (0.025% of reading + 1 count)</td> </tr> </tbody> </table>		Range	Specification	20 mV	± (0.03% of reading + 2 counts)	200 mV through 200 V	± (0.02% of reading + 1 count)	1000 V	± (0.025% of reading + 1 count)	Accuracy: 1 year + 23°C ± 5°C <table border="1"> <thead> <tr> <th>Range</th> <th>Specification</th> </tr> </thead> <tbody> <tr> <td>200 μA, 2 mA</td> <td>± (0.07% of reading + 1 count)</td> </tr> <tr> <td>20 mA</td> <td>± (0.11% of reading + 1 count)</td> </tr> <tr> <td>200 mA, 2000 mA</td> <td>± (0.6% of reading + 1 count)</td> </tr> </tbody> </table>		Range	Specification	200 μA, 2 mA	± (0.07% of reading + 1 count)	20 mA	± (0.11% of reading + 1 count)	200 mA, 2000 mA	± (0.6% of reading + 1 count)
Range	Specification																		
20 mV	± (0.03% of reading + 2 counts)																		
200 mV through 200 V	± (0.02% of reading + 1 count)																		
1000 V	± (0.025% of reading + 1 count)																		
Range	Specification																		
200 μA, 2 mA	± (0.07% of reading + 1 count)																		
20 mA	± (0.11% of reading + 1 count)																		
200 mA, 2000 mA	± (0.6% of reading + 1 count)																		
Temperature Coefficient (0°C to 50°C): ± 0.003% of Reading/°C Effective Common-Mode Rejection (with 1 kΩ imbalance in either lead): AC: > 120 dB at 50/60 Hz ± 0.1% AC Normal-Mode Rejection: > 60 dB at 50/60 Hz ± 0.1% Input Resistance: 20 mV through 2 V ranges: (80% R.H.) ≥ 10 ¹⁰ Ω 20 V through 1,000 V ranges: 10 MΩ ± 1%		Temperature Coefficient (0°C to 50°C): <table border="1"> <thead> <tr> <th>Range</th> <th>Specification ± (% of Reading)/°C</th> </tr> </thead> <tbody> <tr> <td>200 μA</td> <td>± 0.006%</td> </tr> <tr> <td>2 mA, 20 mA</td> <td>± 0.004%</td> </tr> <tr> <td>200 mA, 2,000 mA</td> <td>± 0.01%</td> </tr> </tbody> </table>		Range	Specification ± (% of Reading)/°C	200 μA	± 0.006%	2 mA, 20 mA	± 0.004%	200 mA, 2,000 mA	± 0.01%								
Range	Specification ± (% of Reading)/°C																		
200 μA	± 0.006%																		
2 mA, 20 mA	± 0.004%																		
200 mA, 2,000 mA	± 0.01%																		
AC VOLTMETER		AC AMMETER																	
Ranges: 200 mV, 2 V, 20 V, 200 V, 500 V (500 V Max) Overrange: The maximum reading decreases linearly from 19,999 at 10 kHz to 10,000 at 20 kHz. Accuracy: 1 year + 23°C ± 5°C		Ranges: 200 μA, 2 mA, 20 mA, 200 mA, 2,000 mA Overrange: The maximum reading decreases linearly from 19,999 at 10 kHz to 10,000 at 20 kHz. Accuracy: (1 year, + 23°C ± 5°C)																	
Temperature Coefficient (0°C to 50°C): ± (0.005% of Reading + .2 counts)/°C Input Impedance: 1 M ± 1% shunted by < 100 pF		Temperature Coefficient (0°C to 50°C): ± 0.01% of Reading/°C Protection: 2A/250 V fuse (normal blow) Voltage Burden:																	
<table border="1"> <thead> <tr> <th>Range</th> <th>Max Burden at Full Scale</th> </tr> </thead> <tbody> <tr> <td>200 μA – 200 mA</td> <td>< 250 mV</td> </tr> <tr> <td>2,000 mA</td> <td>< 700 mV</td> </tr> </tbody> </table>		Range	Max Burden at Full Scale	200 μA – 200 mA	< 250 mV	2,000 mA	< 700 mV	<table border="1"> <thead> <tr> <th>Range</th> <th>Max Burden at Full Scale</th> </tr> </thead> <tbody> <tr> <td>200 μA – 200 mA</td> <td>< 250 mV</td> </tr> <tr> <td>2,000 mA</td> <td>< 700 mV</td> </tr> </tbody> </table>		Range	Max Burden at Full Scale	200 μA – 200 mA	< 250 mV	2,000 mA	< 700 mV				
Range	Max Burden at Full Scale																		
200 μA – 200 mA	< 250 mV																		
2,000 mA	< 700 mV																		
Range	Max Burden at Full Scale																		
200 μA – 200 mA	< 250 mV																		
2,000 mA	< 700 mV																		
DC AMMETER		OHMMETER																	
Ranges: 200 μA, 2 mA, 20 mA, 200 mA, 2,000 mA Maximum Input: 2 A from < 250 V source Protection: 2 A/250 V fuse (normal blow)		Ranges: 200 Ω, 2 kΩ, 20 kΩ, 200 kΩ, 2,000 kΩ, 20 MΩ Accuracy: (1 year + 23°C ± 5°C)																	
<table border="1"> <thead> <tr> <th>Range</th> <th>Specification</th> </tr> </thead> <tbody> <tr> <td>200 Ω</td> <td>± (0.02% of reading + 2 counts)</td> </tr> <tr> <td>2 kΩ through 2 MΩ</td> <td>± (0.02% of reading + 1 count)</td> </tr> <tr> <td>20 MΩ</td> <td>± (.1% of reading + 1 count)</td> </tr> </tbody> </table>		Range	Specification	200 Ω	± (0.02% of reading + 2 counts)	2 kΩ through 2 MΩ	± (0.02% of reading + 1 count)	20 MΩ	± (.1% of reading + 1 count)	<table border="1"> <thead> <tr> <th>Range</th> <th>Specification</th> </tr> </thead> <tbody> <tr> <td>200 Ω</td> <td>± (0.02% of reading + 2 counts)</td> </tr> <tr> <td>2 kΩ through 2 MΩ</td> <td>± (0.02% of reading + 1 count)</td> </tr> <tr> <td>20 MΩ</td> <td>± (.1% of reading + 1 count)</td> </tr> </tbody> </table>		Range	Specification	200 Ω	± (0.02% of reading + 2 counts)	2 kΩ through 2 MΩ	± (0.02% of reading + 1 count)	20 MΩ	± (.1% of reading + 1 count)
Range	Specification																		
200 Ω	± (0.02% of reading + 2 counts)																		
2 kΩ through 2 MΩ	± (0.02% of reading + 1 count)																		
20 MΩ	± (.1% of reading + 1 count)																		
Range	Specification																		
200 Ω	± (0.02% of reading + 2 counts)																		
2 kΩ through 2 MΩ	± (0.02% of reading + 1 count)																		
20 MΩ	± (.1% of reading + 1 count)																		

Table 1-2. General Information.

<p>Temperature Coefficient (0°C to 50°C):</p> <table border="1"> <thead> <tr> <th>Range</th> <th>Specification ± (% of Reading)/°C</th> </tr> </thead> <tbody> <tr> <td>200 Ω through 2 MΩ</td> <td>± 0.0015%</td> </tr> <tr> <td>20 MΩ</td> <td>± 0.004%</td> </tr> </tbody> </table>		Range	Specification ± (% of Reading)/°C	200 Ω through 2 MΩ	± 0.0015%	20 MΩ	± 0.004%	<p>Nominal current through unknown resistance:</p> <table border="1"> <thead> <tr> <th>Range</th> <th>Current</th> </tr> </thead> <tbody> <tr> <td>200 Ω</td> <td>1 mA</td> </tr> <tr> <td>2 kΩ</td> <td>1 mA</td> </tr> <tr> <td>20 kΩ</td> <td>10 μA</td> </tr> <tr> <td>200 kΩ</td> <td>10 μA</td> </tr> <tr> <td>2000 kΩ</td> <td>1 μA</td> </tr> <tr> <td>20 MΩ</td> <td>0.1 μA</td> </tr> </tbody> </table>		Range	Current	200 Ω	1 mA	2 kΩ	1 mA	20 kΩ	10 μA	200 kΩ	10 μA	2000 kΩ	1 μA	20 MΩ	0.1 μA
Range	Specification ± (% of Reading)/°C																						
200 Ω through 2 MΩ	± 0.0015%																						
20 MΩ	± 0.004%																						
Range	Current																						
200 Ω	1 mA																						
2 kΩ	1 mA																						
20 kΩ	10 μA																						
200 kΩ	10 μA																						
2000 kΩ	1 μA																						
20 MΩ	0.1 μA																						
<p>Maximum Input Voltages: Between Input HIGH (V, Ω) and COM:</p> <table border="1"> <thead> <tr> <th>Function</th> <th>Max Voltage</th> </tr> </thead> <tbody> <tr> <td>DC Volts</td> <td>1000 V (dc + peak ac)</td> </tr> <tr> <td>AC Volts</td> <td>600 V dc; 500 V ac rms; 800 V peak ac</td> </tr> <tr> <td>Ohms</td> <td>350 V (dc + peak ac)</td> </tr> </tbody> </table> <p>Between COM terminal and gr: ± 500 V (dc + peak ac)</p>		Function	Max Voltage	DC Volts	1000 V (dc + peak ac)	AC Volts	600 V dc; 500 V ac rms; 800 V peak ac	Ohms	350 V (dc + peak ac)	<p>Power Requirements: Power: AC Line; 48 – 440 Hz</p> <p>86 – 106 V Option 100 104 – 127 V Option 115 190 – 233 V Option 210 208 – 250 V Option 230</p> <p>Battery (Rechargeable NiCad): 6 hours minimum continuous operation</p> <p>Recharge Time: 8 hours (instrument off)</p> <p>Total Instrument Power Dissipated:</p> <p>Instrument on, Battery Operation: < 1 watt Instrument on, Line Operation: < 10 VA</p> <p>Battery Test: Depress DCV and 10 MΩ; Recharge NiCad batteries if the display reading is < 0.380.</p> <p>Environments: Considerations: Operating temperature: 0°C to 40°C (32°F to 104°F) Humidity range: 95% at 40°C Storage temperature: - 20°C to + 50°C (- 4°F to 122°F)</p>													
Function	Max Voltage																						
DC Volts	1000 V (dc + peak ac)																						
AC Volts	600 V dc; 500 V ac rms; 800 V peak ac																						
Ohms	350 V (dc + peak ac)																						
<p>Reading Rate: 2.5 samples per second Overload Indication: Display Blanks except for overrange "1" and decimal point (also polarity sign on DCV or DCA FUNCTIONS).</p> <p>Ohms Terminal Characteristics: Configuration: 2 wire Open-circuit voltage: < 5 V max. Overload protection: 350 V (dc + peak ac)</p>																							



Maximum Input Voltages:

Between Input HIGH (V Ω) and COM:

Function	Max Voltage
DC Volts	1000 V (dc + peak ac)
AC Volts	600 V dc; 500 V ac rms; 800 V peak ac
Ohms	350 V (dc + peak ac)

SECTION II INSTALLATION

2-1. INTRODUCTION.

2-2. This section contains information and instructions for the installation and shipping of the Multimeter. Included are initial inspection procedures, power and grounding requirements, environmental information and instructions for repackaging for shipment.

2-3. INITIAL INSPECTION.

2-4. This instrument was carefully inspected both mechanically and electrically before shipment. It should be free of marks or scratches and in perfect electrical order upon receipt. To confirm this, the instrument should be inspected for physical damage in transit, and the electrical performance should be tested using the performance tests outlined in Section V. If there is damage or deficiency, see the warranty inside the front of this manual.

2-5. POWER REQUIREMENTS.

2-6. This Multimeter will operate on ac line voltage or from internal rechargeable NiCad batteries. AC line voltage options are described in Table 1-2.



Verify that the ac power source matches the power requirement of the instrument as marked on the option label affixed to the rear of the instrument.

2-7. GROUNDING REQUIREMENTS.

2-8. To protect operating personnel, the National Electrical Manufacturers Association (NEMA) recommends that the instrument panel and cabinet be grounded. Multimeters are equipped with a three-conductor power cable which, when plugged into an appropriate receptacle, grounds the instrument. The offset pin on the power cable is the ground wire.

2-9. To preserve the protection feature when operating from a two-contact outlet, use a three-prong to two-prong adapter and connect the green pigtail on the adapter to power line ground.

2-10. ENVIRONMENTAL REQUIREMENTS.

2-11. The Multimeter should not be operated outside the ambient temperature range of 0°C to 40°C (32°F to

104°F) or stored outside the ambient temperature range of -20°C to +50°C (-4°F to 122°F).

WARNING

To prevent potential electrical or fire hazard, do not expose equipment to rain or moisture.

2-12. REPACKAGING FOR SHIPMENT.

2-13. The following paragraphs contain a general guide for repackaging the instrument for shipment. Refer to Paragraph 2-14 if the original container is to be used; 2-15 if it is not. If you have any questions, contact your nearest -hp- Sales and Service Office (see back of Manual for office locations).

NOTE

If the instrument is to be shipped to Hewlett-Packard for service or repair, attach a tag to the instrument identifying the owner and indicating the service or repair to be accomplished. Include the model number and full serial number of the instrument. In any correspondence, identify the instrument by model number and full serial number.

2-14. Place instrument in original container with appropriate packing material and seal well with strong tape or metal bands. If original container is not available, one can be purchased from your nearest -hp- Sales and Service Office.

2-15. If original container is not to be used, proceed as follows:

- a. Wrap instrument in heavy paper or plastic before placing in an inner container.
- b. Place packing material around all sides of instrument and protect panel face with cardboard strips.
- c. Place instrument and inner container in a heavy carton or wooden box and seal with strong tape or metal bands.

2-16. POWER CORDS AND RECEPTACLES.

2-17. Figure 2-1 illustrates the plug cap configurations that

are available to provide ac power to the Multimeter. The -hp- part number shown directly below each plug cap drawing is the part number for the power cord set equipped with the appropriate mating plug for that receptacle. The appropriate power cord should be provided with each instrument. However, if a different power cord set is required, notify the nearest -hp- Sales and Service Office and a replacement cord will be provided. The instrument ac power input receptacle and cord set appliance coupler meet the safety specifications set by the International Commission on Rules for the Approval of Electrical Equipment (CEE 22).

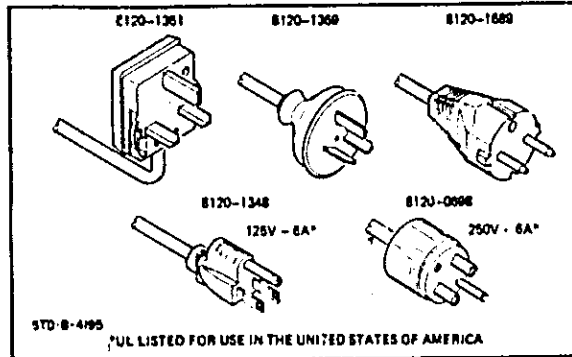

Figure 2-1. Power Receptacles.

SECTION III

OPERATING INSTRUCTIONS

3-1. INTRODUCTION.

3-2. This section contains instructions for using the Multimeter for making dc voltage, ac voltage, dc current, ac current and ohms measurements. The section also contains a description of the front and rear panel features.

WARNING

To prevent potential electrical or fire hazard, do not expose the Multimeter or its accessories to rain or moisture.

3-3. Front Panel Features.

3-4. An illustration and description of the front panel is provided in Figure 3-1. All controls and connectors are identified and briefly described.

3-5. Turn-on and Warm-up.

3-6. For specified measurement accuracy, allow the instrument to warm-up for at least 10 minutes.

CAUTION

Before connecting the instrument to ac power, verify that the ac power source matches the power requirement of the instrument as marked on the option label affixed to the rear of the instrument.

3-7. Internal Battery Voltage Measurement and Recharging.

3-8. The Multimeter contains a feature allowing the user to check battery strength to determine the need for battery recharging. The procedure is to place the Multimeter in the DCV function and depress the 20 megohms range switch. If the absolute value of the front panel display is .380 or less, recharge the batteries. Recharging of the NiCad batteries is performed by operating the Multimeter on an ac source. Measurements can be made with the Multimeter operated from the ac source during the recharging period.

NOTE

After 8 hours, a completely discharged battery will be fully charged with ac line voltage connected and the POWER switch off. Shorter charge periods will allow reduced battery

operating time. There is no danger of overcharge. For convenience, overnight charging is recommended.

3-9. Low Battery Voltage Detection.

3-10. A battery source safety feature of the Multimeter is low battery voltage detection circuit which turns the instrument off when battery voltage reaches a low level. This protects against cell reversal of the NiCad batteries. If during operation the display disappears or immediately after turn-on the display appears and disappears after several seconds, low battery voltage is indicated. To verify low battery voltage, the procedure described in the preceding paragraph can be used or verify by placing the OFF/ON switch to OFF and to ON again. The display will appear and again disappear. Operation from an ac line source and recharging of the NiCad batteries is required when this occurs.

NOTE

In protecting batteries and circuitry, the low battery voltage detection circuit may shut down the instrument if the power switch is momentarily turned off then back on. To restore normal operation, the instrument should be turned off with the front panel power switch for a minimum of 3 seconds.

3-11. Overload Indication.

3-12. The Multimeter is capable of displaying 19999 for all functions and ranges. There are maximum voltage limitations in DCV and ACV, however (see ac and dc voltage measurement paragraphs). In an overload condition where the input exceeds 19999, the last four digits blank and the overrange "1" and decimal point will be displayed. The polarity sign is also displayed in the dc volts and dc current functions in the overload condition.

3-13. AC VOLTAGE MEASUREMENTS.



CAUTION

Maximum input voltage in the ACV FUNCTION is 500 V rms, 800 V peak and 600 V dc. Do not exceed these voltages or damage to the instrument will occur.

3-14. AC Voltage Ranges.

3-15. The ACV FUNCTION has five ranges from 200 mV to 500 V. Each range has a maximum display reading of

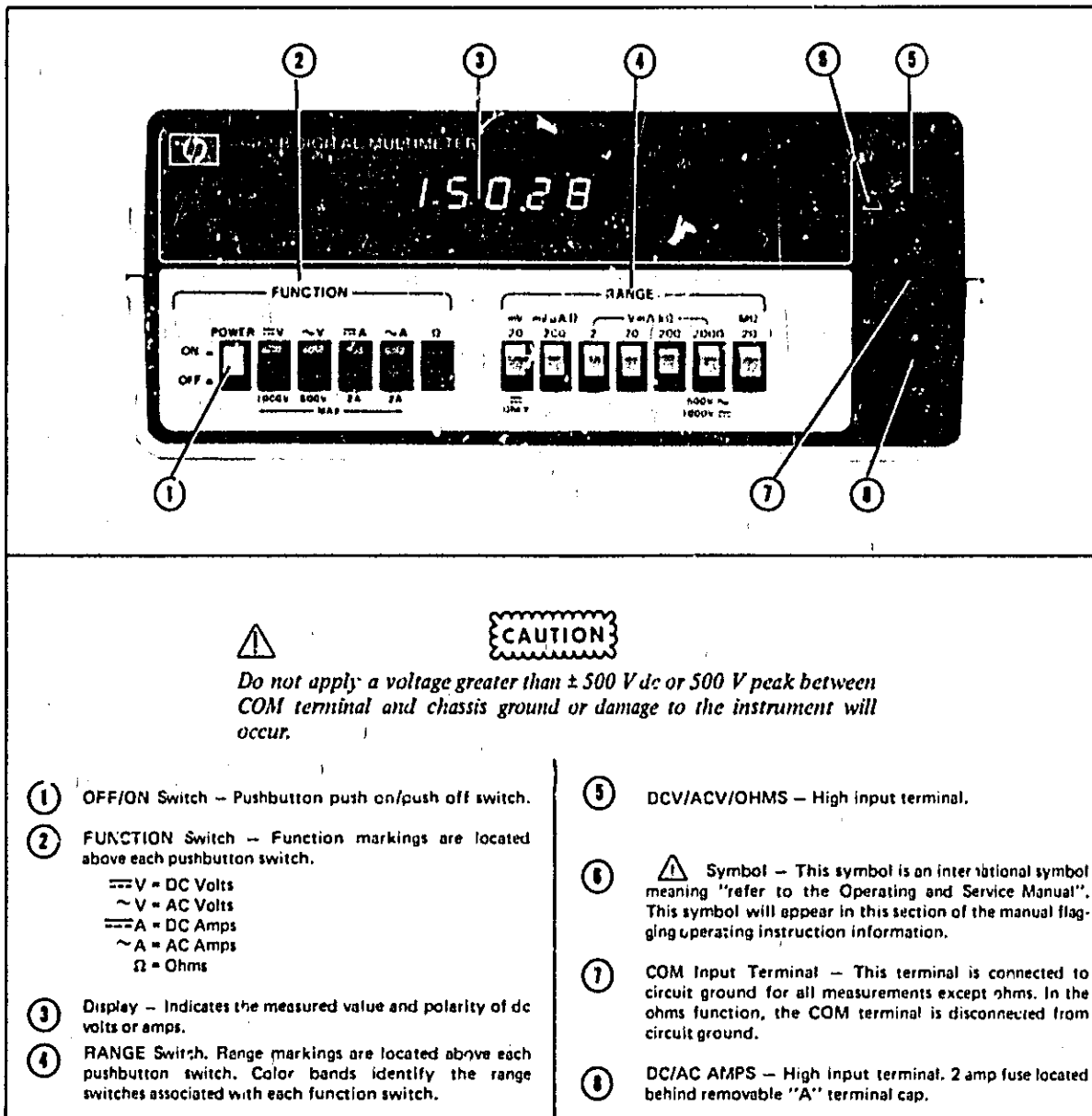

CAUTION

Do not apply a voltage greater than ± 500 V dc or 500 V peak between COM terminal and chassis ground or damage to the instrument will occur.

- | | |
|--|---|
| <p>① OFF/ON Switch – Pushbutton push on/push off switch.</p> <p>② FUNCTION Switch – Function markings are located above each pushbutton switch.</p> <p style="margin-left: 20px;"> $\text{—} \text{V}$ = DC Volts
 $\sim \text{V}$ = AC Volts
 $\text{—} \text{A}$ = DC Amps
 $\sim \text{A}$ = AC Amps
 Ω = Ohms </p> <p>③ Display – Indicates the measured value and polarity of dc volts or amps.</p> <p>④ RANGE Switch. Range markings are located above each pushbutton switch. Color bands identify the range switches associated with each function switch.</p> | <p>⑤ DCV/ACV/OHMS – High input terminal.</p> <p>⑥ Symbol – This symbol is an international symbol meaning "refer to the Operating and Service Manual". This symbol will appear in this section of the manual flagging operating instruction information.</p> <p>⑦ COM Input Terminal – This terminal is connected to circuit ground for all measurements except ohms. In the ohms function, the COM terminal is disconnected from circuit ground.</p> <p>⑧ DC/AC AMPS – High Input terminal. 2 amp fuse located behind removable "A" terminal cap.</p> |
|--|---|

Figure 3-1. Front Panel Features.

19999. However, the 500 V range is limited to a maximum ac input voltage of 500 V.

3-16. DC VOLTAGE MEASUREMENTS.



CAUTION

Do not exceed a maximum input voltage of 1000 V (dc + peak ac) on the 500 V range or damage to the instrument will occur.

3-17. 20 mV Range Zero Adjust.

3-18. When using the Multimeter on the 20 mV range in DC volts, short the input terminals and zero the Multimeter display with the rear panel ZERO ADJ control. The display should indicate 0.000 before proceeding with measurements.

3-19. DC Voltage Ranges.

3-20. DC Voltage measurements can be made from 20 mV to 1000 V full-range. Each range has a maximum display reading of 19999. However, the 1000 V range is limited to maximum input of 1000 V dc and peak ac (see DC Voltage measurements caution in Paragraph 3-16).

3-21. CURRENT MEASUREMENTS.

Do not exceed a maximum input voltage of 350 V dc + peak ac or a maximum dc or ac rms input current of 2 A or the amps fuse, located directly behind the "A" terminal, will open. See the following paragraph for replacement instructions.

3-22. The Multimeter is protected from the application of excessive current by a 2 A fuse located directly behind the front panel "A" terminal. If it is necessary to replace this fuse, use the side slots on the "A" terminal to rotate the terminal. The terminal and fuse will protrude from the front panel. Remove the terminal and fuse, replace fuse with a 2 A rated fuse as listed in Table 6-3 Miscellaneous Parts General, and designated F1.

3-23. AC Current Ranges.

3-24. AC current measurements are specified over a frequency range of 40 Hz to 20 kHz. There are five current ranges from 200 μ A to 2000 mA. See current measurements Caution in Paragraph 3-21.

3-25. DC Current Ranges.

3-26. DC Current measurements can be made on five current ranges from 200 μ A to 2000 mA. See current measurements caution in Paragraph 3-21.

3-27. OHMS MEASUREMENTS.

Do not apply voltage greater than ± 250 V dc + Peak AC between the ohms and common input terminals in the ohms function or damage to the instrument will occur.

3-28. Ohmmeter Ranges.

3-29. Resistance measurements can be made on six ranges from 200 ohms to 20 megohms. Both input terminals (Ω and COM) are floating with respect to circuit ground.

3-30. Ohmmeter Reference Current.

3-31. The ohmmeter reference current through the unknown resistance for each range is shown in Table 3-1.

Table 3-1. Ohmmeter Current Through Unknown.

Range	Current Through Unknown
200 Ω	1 mA
2 k Ω	1 mA
20 k Ω	10 μ A
200 k Ω	10 μ A
2000 k Ω	1 μ A
20 M Ω	0.1 μ A

Maximum open-circuit voltage at the ohms input terminals is less than 5 V.

SECTION IV THEORY OF OPERATION

4-1. INTRODUCTION.

4-2. This section contains the theory of operation for the Multimeter. The information is divided into two parts:

- a. Simplified Theory
- b. Detailed Theory

The simplified theory provides an overview of the operation of each section in the Multimeter while the detailed theory describes the circuit operation of each section.

4-3. Description.

4-4. The Multimeter is a five-function, 4-1/2 digit multimeter. The five functions measured are dc volts, ac volts,

dc current, ac current and ohms. The dual-slope integration technique is used for measurements. This technique charges an integrator for a fixed length of time, to a voltage proportional to the input signal, then discharges the integrator at a fixed rate determined by a known reference voltage. The measurement display is determined by the discharge time of the integrator, which is proportional to the input signal.

4-5. Figure 4-1, Basic Block Diagram and Measurement Sequence, illustrates the major functional blocks of the Multimeter. The illustration of the measurement sequence shows the integrator output for each interval of a measurement cycle. This diagram is to supplement the functional block diagram for the simplified theory discussion.

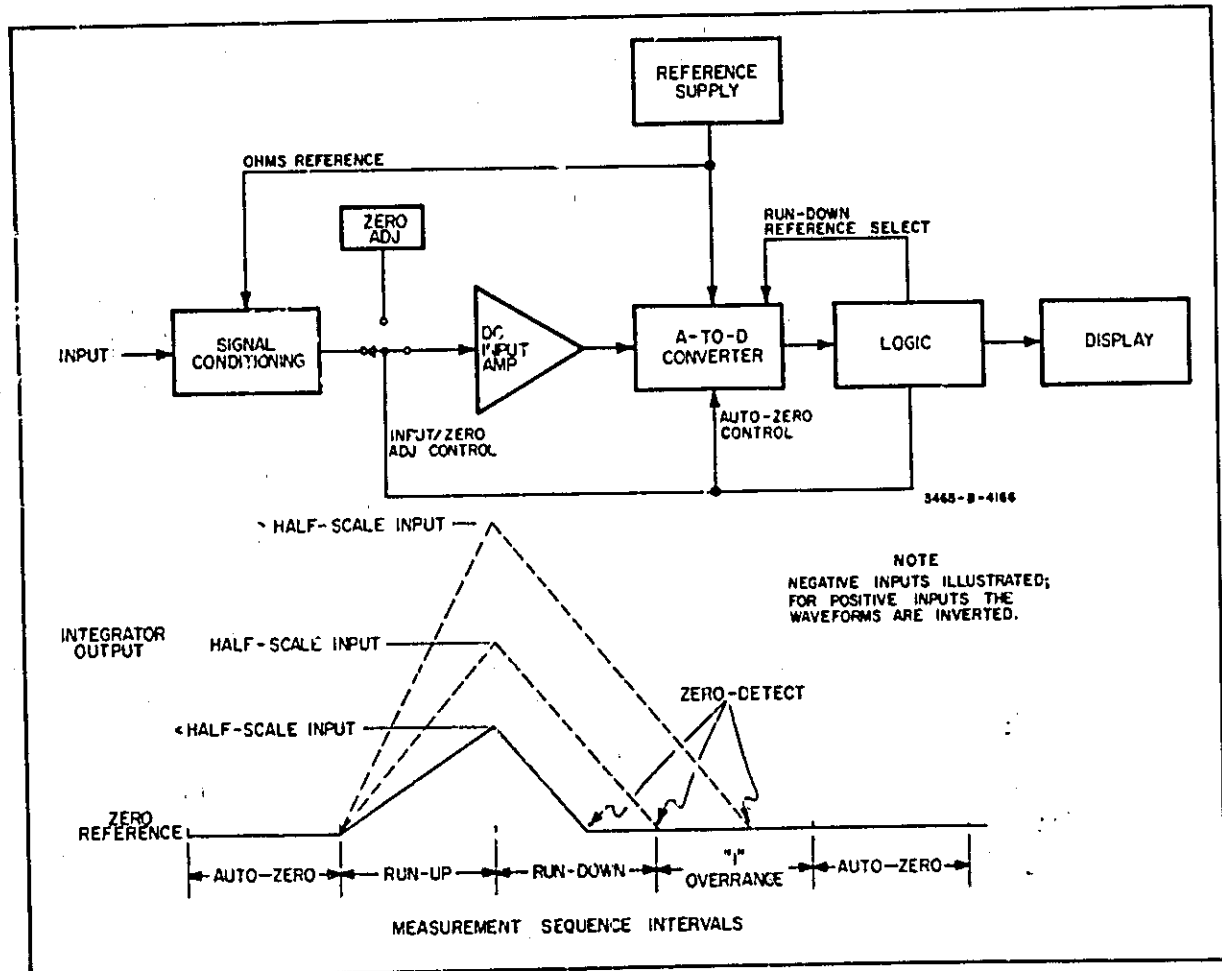

Figure 4-1. Basic Block Diagram and Measurement Sequence.

4-6. SIMPLIFIED THEORY.

4-7. A simplified theory of operation of the Multimeter is presented in the following paragraphs. The simplified theory describes each section of the functional block diagram, Figure 7-1. These sections are the signal conditioning section, analog-to-digital section, logic section and the display section. Also presented is a simplified description of the power supply. Refer to Figure 7-1, Functional Block Diagram, and Figure 4-1, Basic Block Diagram and Measurement Sequence, for this discussion.

4-8. Signal Conditioning.

4-9. Signal conditioning consists of attenuating and/or converting the input signal to a dc voltage within the working limits of the input amplifier. For full-scale inputs, this voltage can vary from 20 mV dc to 2 V dc depending on the function and range.

4-10. The signal conditioning section consists of current shunts, an input attenuator, ohms converter and an ac-to-dc converter. The output from the signal conditioning section is applied to the input amplifier during the run-up interval of the measurement sequence. The Input Amplifier Gain Table located on Figure 7-3 indicates the full-scale input level applied to the input amplifier for each function and range. This signal is the output of the signal conditioning section.

4-11. **Ohms Converter.** The ohms converter is a high gain integrating amplifier. A simplified diagram of the ohms converter is presented in Figure 4-2. The blocks of the ohms converter are the integrating amplifier, protection diodes, over-voltage protection circuit and the overload loop. An integrating amplifier is used because this type of amplifier is less susceptible to oscillations. The protection diodes clamp the Ω terminal to a voltage of about 1.2 V in the positive direction or 0.7 V in the negative direction.

With the Ω terminal clamped, protection against excessive voltages applied to the ohms terminals is provided by an over-voltage protection circuit located between the ohms amplifier and the terminal. For excessive voltages, this circuit isolates the COM terminal from the ohms amplifier.

4-12. Figure 4-2 shows two outputs of the ohms converter being applied to the input amplifier. The ohms output is the ohms converter measurement signal and the auto-zero output is the ohms amplifier dc offset signal which is called the auto-zero (AZ) signal. This AZ signal is applied to the input amplifier during the auto-zero interval of the measurement sequence and establishes the reference for the analog-to-digital converter. An AZ signal greater than ± 1 mV causes the instrument readings to be invalid. This condition (AZ signal $> \pm 1$ mV) is present when the unknown resistance, R_x , is removed and an open loop is present on the ohms amplifier. To maintain the AZ signal at $< \pm 1$ mV when an open loop is present, an overload feedback circuit is used.

4-13. The ohms output, (LO terminal of the ohms converter) is applied to the input amplifier. This output is a dc voltage, the level of which is dependent on the ratio of the unknown resistance, R_x , to the variable resistance, 10^n , and the ohms reference supply. The variable resistance, 10^n , is a resistor string located in the precision resistor pack R75. The value of 10^n is selected by the range switches shorting those resistors in the string that are not required. The value of 10^n can range from 10 k Ω to 10 M Ω . A discussion of the precision resistor pack R75 can be found in the detailed theory.

4-14. The formula for the ohms converter output voltage is:

$$\text{Ohms Output Voltage} = \left[\frac{R_x}{10^n} \right] \text{Reference Supply Voltage} + V_{\text{offset}}$$

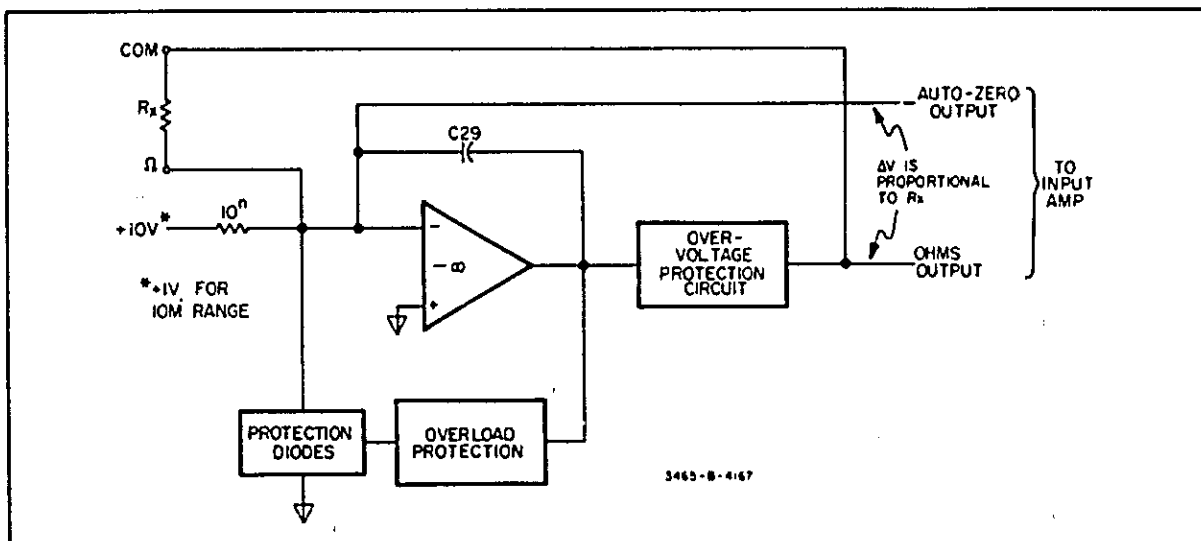

Figure 4-2. Simplified Diagram, Ohms Converter.

The reference supply is +10 V for all ranges except the 20 M range. For this range the reference supply is +1 V. On the 20 M range with a R_X of 20 M Ω , an output of 2 V dc is needed. From the formula for the ohms output, it can be seen that 10^n is 10 k Ω to 10 M Ω , a 10^n of 10 M Ω combined with a reference supply of 1 V provides the desired 1 V dc full-scale ohms converter output.

4-15. AC-DC Converter. The ac-dc converter is an average responding ac converter. It measures the average value of a sine wave and multiplies this by a fixed scale factor to convert it to an rms value. The output of the converter is a dc voltage equal to the rms value of the sine wave.

4-16. Figure 4-3 is a block diagram of the ac-dc converter. The blocks consist of an impedance converter, an ac converter and a filter. The impedance converter has a high input impedance to prevent loading of the input signal. It also provides the gain necessary to drive the ac converter. An impedance converter gain of unity, 9.964 or 10 is selected by the function and range switching. The gain of 9.964 is used with the ac current function and the gain of 10 is used with the 200 mV, .2 mA, 200 Ω and 20 V, 20 mA, 20 k Ω ranges.

4-17. The ac converter amplifies the signal from the impedance converter by the scale factor. This converts the average value of the sine wave to the rms value. Half-wave rectification of the sine wave is also performed by the ac converter. This rectified signal is filtered to provide the proportional dc output which is applied to the analog-to-digital converter.

4-18. Analog-to-Digital (A-D) Converter.

4-19. The A-D converter block is comprised of an input amplifier, reference supply, integrator, slope amplifier, comparator and auto-zero circuit. It makes an analog-to-digital conversion using the dual-slope integrating technique. Four control state signals from the logic section (I0, IZ, I1 and I2) regulate the measurement sequence. I0 and IZ regulate the input amplifier and auto-zero switching respectively while I1 and I2 select the reference supply required during the run-down interval.

4-20. Input Amplifier. The first stage of the A-D converter is the input amplifier. During the run-up interval of the measurement sequence, control state signal I0 switches the output of the signal conditioning block to the input amplifier. The output of the signal conditioning block is a dc voltage which varies between 10 mV and 1 V for full-scale inputs, depending on the function and range selected. The gain of the input amplifier is adjusted by the function and range switching to provide an output of 2 V dc for any full-scale input signal. See Input Amplifier Gain Table on Figure 7-3.

4-21. Reference Supply. The A-D converter uses a monopolar reference supply of +10 V. A reference voltage is applied to the integrator during the run-down interval to discharge the integrating capacitor. Since the discharge rate is constant, the time required for the integrator to reach a zero reference is proportional to the input signal. This time period is the run-down interval and is processed to determine the display. A positive and negative reference voltage is required since the input signal can be either polarity. A detailed discussion of the operation of the monopolar reference supply can be found in the detailed theory.

4-22. Integrator. The integrator output is a result of a current summation at the integrator summing junction (inverting input). A positive current summation (current flowing into the integrator input) will cause the integrator to ramp negative. A negative current summation (current flowing out of the integrator input) will cause the integrator to ramp positive. The integrator sums currents from the input amplifier, reference supply, -7 V supply and the auto-zero loop during designated times.

4-23. Slope Amplifier. Following the integrator is a X4000 amplifier. This amplifier is divided into two stages; the first with a gain of 40 and the second with a gain of 100. The slope amplifier amplifies the integrator output to provide a more vertical crossing of this output with the reference level. This provides greater accuracy of the voltage-to-time conversion during the run-down interval.

4-24. Comparator. The comparator provides two logic outputs; a high output of 0 V or a low output of -7 V. The comparator output is high when the integrator output is greater than the reference level. The comparator is low when the integrator output is less than the reference level.

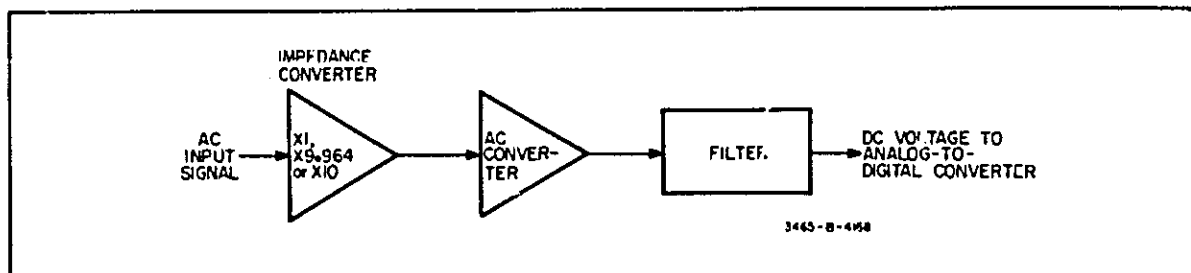

Figure 4-3. Block Diagram, AC-to-DC Converter.

This logic level is sensed by the logic section to determine polarity and zero-detect.

4-25. Auto-Zero Circuit. During the measurement sequence, the auto-zero loop is closed except for the run-up and run-down intervals. This loop includes the slope amplifier and the integrator but does not physically include the input amplifier although the loop does compensate for the input amplifier offset. When the auto-zero loop is closed, the input of the input amplifier is grounded. If the summation of currents at the integrator summing junction is not zero, the integrator begins to ramp up for a negative summation or ramp down for a positive summation. The integrator output is applied through the X4000 slope amplifier to the auto-zero capacitor, C4. The voltage on the auto-zero capacitor causes a current to flow at the summing junction that returns the summation to zero. This auto-zero configuration compensates for the analog offset of the input amplifier and integrator by providing a current at the summing junction that cancels the currents resulting from the offset.

4-26. Logic Section.

4-27. The Logic Section is comprised of combinational and state logic. This section processes the comparator output to determine the polarity of the input signal and to make a voltage-to-time conversion of the input signal. Time accumulated during the conversion is proportional to the input signal and is stored. The display is derived from this accumulated time. A voltage-to-time conversion with the accumulated time being stored occurs once each measurement sequence.

4-28. Seven blocks make up the logic section. These blocks are:

- a. Clock
- b. State Clock
- c. Polarity and Zero Detect
- d. Data Transfer and Reset
- e. Control State Counter
- f. Control State Decode
- g. Data Accumulator

The HIGH and LOW logic levels used in the logic section are 0 V and -7 V respectively. The following discussion describes the basic operation of the logic section.

4-29. Clock and State Clock. The timing of the logic section is derived from the clock circuit. The clock operates at 100 kHz and is crystal-controlled. A state clock, driven by the clock output and the count extend line from the data accumulator, drives the control state counter to initiate each measurement interval.

4-30. Polarity and Zero Detect. The polarity and zero-detect circuit monitors the comparator output. The state of this output at the beginning of the run-down interval determines the polarity of the input signal. Zero-detect is determined at the point the comparator output changes states during the run-down, overrange or overflow intervals.

If the integrator ramps positive (negative input signal) during run-up, the comparator output goes HIGH and returns to LOW at the zero-detect point. If the integrator ramps negative (positive input signal) during run-up, the comparator output goes low and returns to high at the zero-detect point. These comparator output logic states are stored in a D flip-flop. At the beginning of the run-down interval, this state identifies the polarity of the input signal. The outputs of the D flip-flop provide the signals needed to select the correct polarity display and the correct reference supply signal (I1, I2) during the run-down interval. An EXCLUSIVE OR and latch processes the comparator output to provide the zero-detect signal.

4-31. Data Transfer and Reset. The data transfer and reset circuits provide logic signals to the data accumulator required to load the storage latches and reset the decade counters. A detailed description of the data accumulator is provided in the detailed theory section. While the TXFR input of the data accumulator is low, data in the decade counters is transferred to the static storage latches. The RESET input resets the decade counters to zero when low. This must occur after the transfer to the storage latches has taken place. To ensure that reset occurs after termination of transfer, an RC delay circuit precedes the reset gates.

4-32. Control State Counter. The control state counter provides the timing for the measurement sequence intervals. The output from the counter establishes the timing of the analog control signals (IZ, IO, I1 and I2) which are applied to the A-D converter. The state clock and reset inputs to the control state counter determine the outputs of the counter.

4-33. Control State Decode. The control state decode converts the polarity, zero-detect and control state counter inputs to the correct analog control signals. These signals, applied to the A-D converter, perform the measurement sequence switching. This switching consists of the input amplifier switch, the auto-zero switch and the reference supply switches.

4-34. Data Accumulator. The data accumulator consists of a counter, data latches, a multiplexer, digit select decoder and output buffers. At the beginning of the Run-Down interval of the measurement sequence, the data accumulator begins to count clock pulses until zero-detect occurs. This count is proportional to the input signal and is the time conversion used to generate the display. The digit select decoder scans the display digits from the most significant digit to the least significant digit while the multiplexer provides the corresponding BCD outputs for each digit. A detailed discussion of the data accumulator is presented in the detailed theory.

4-35. Display.

4-36. The multimeter display contains four full digits with an overrange "1" and polarity sign. All segments and indicators are light-emitting diodes. A BCD-to-seven segment decoder receives BCD information from the data accumu-

lator and applies the seven-segment code to the display drivers. The display driver apply the seven-segment code to all digits simultaneously. Digit strobe lines activate the digit corresponding to the seven-segment code at that point in time. Scanning of the digits is from the most significant to the least significant digit. To complete the display, the proper decimal point is enabled by range switching.

4-37. Power Supply.

4-38. Figure 4-4 is a block diagram of the power supply. The power supply develops three output voltages from a single dc output voltage (+V_B). This dc input voltage is applied to a dc-to-dc converter which develops output voltages of +11 V dc and -7 V dc. A series regulated +10 V output is developed from the +11 V converter output. This +10 V is used as the reference voltage in the A-D converter and to develop the reference current in the ohms converter and as the reference voltage for the converter regulator. The converter regulator controls the converter and regulates the -7 V and +11 V outputs of the converter. A discussion of the operation and regulation process of the dc-to-dc converter is presented in the detailed theory.

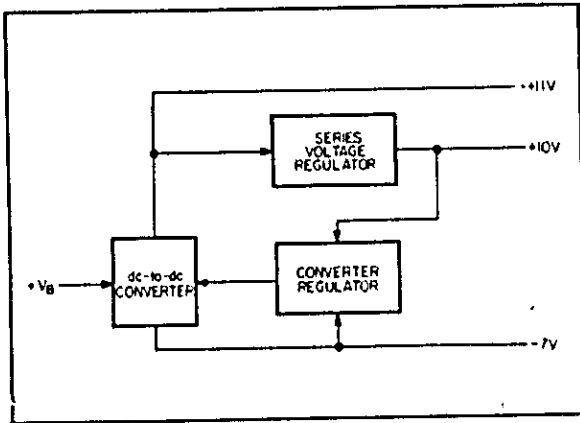

Figure 4-4. Block Diagram, Power Supply.

4-39. DETAILED THEORY.

4-40. This portion of the theory of operation provides a detailed discussion of the circuits in the Multimeter. The circuits described here are the ohms converter, ac-dc converter, monopolar reference supply, data accumulator of the logic section, display and the power supply. A discussion of the precision resistor pack (R75) is also provided. The detailed discussion makes use of the schematics in Section VII.

4-41. Precision Resistor Pack (R75).

4-42. The precision resistor pack, R75, is a laser trimmed substrate providing high precision resistances. A diagram of R75 is shown on Figure 7-2. The input attenuator, power supply, ohms reference supply, A-D reference supply and the input amplifier require highly accurate resistances to

maintain the accuracy of the Multimeter. These resistances are part of the resistor pack. The advantage to the resistor pack is high precision resistors and good temperature tracking. As resistance values of the resistor pack change due to temperature changes, the ratio of the resistors remains the same.

4-43. Ohms Converter.

4-44. Refer to Figure 7-2 for this discussion. Both ends of the ohms converter are floating with respect to the instrument ground. The unknown resistor, R_x, becomes the feedback loop of the ohms amplifier. The ratio of R_x to 10ⁿ determines the gain of the ohms amplifier, Q25 and U15. 10ⁿ is a variable resistance between 10 kΩ and 10 MΩ selected by the range switching. The ohms converter input is the reference voltage provided by the ohms reference supply. This reference voltage times the amplifier gain is the ohms converter output supplied to the input amplifier during the run-up interval. Full-scale ohms converter gain and output values are provided in the ohms converter table located on Figure 7-2.

4-45. The Ω HI LEAD of the ohms converter is connected to the reference supply through 10ⁿ of the resistor pack R75. The Ω HI LEAD is clamped by protection diodes CR15 and CR25 to prevent the destruction of FET Q25 and R75 by the application of large voltages. These diodes clamp the Ω HI LEAD to about 1.2 V positive or 0.7 V negative.

4-46. With the Ω HI LEAD clamped, over-voltage protection must be provided to protect the ohms amplifier from excess voltage. The over-voltage protection circuit is located between the ohms amplifier and the LO terminal point and is shown in Figure 4-5. During normal operation < 2 mA of current flows through Q30, R94 and Q32. If a large voltage is applied to the ohms terminals, the current through this circuit will try to exceed 2 mA. This current will cause a large enough voltage drop across R94 to turn on Q31. When Q31 is on, it removes the base drive from Q30, which turns off, disconnecting the LO terminal point from the ohms converter. Since Q30 is a high voltage transistor, large voltages are not applied to the ohms converter.

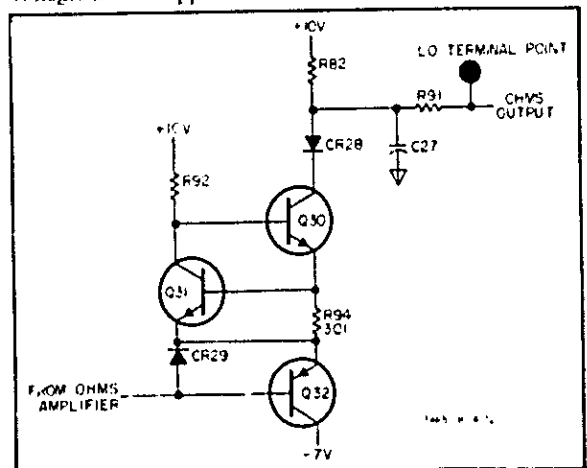

Figure 4-5. Over-Voltage Protection Circuit.

4-47. In the event of open loop ($R_x = \infty$), the ohms amplifier output begins to drive negative. The input (negative port), which is the auto-zero output, could exceed ± 1 mV under an open loop condition due to the lack of negative feedback through an R_x . This auto-zero output must be maintained at $\leq \pm 1$ mV for accurate operation of the A-D converter. To satisfy this requirement, an overload protection circuit consisting of CR23, CR24 and R86 is used. When the ohms amplifier output goes below approximately +1.5 V, the zener diode (CR23) turns off. The overload loop, CR24 and R86, is introduced by the turn-on of CR24 when CR23 is off. This loop provides the negative feedback required to maintain an auto-zero output $< \pm 1$ mV. When an R_x is introduced, CR23 turns-on, CR24 turns-off, and the overload loop is inoperative.

4-48. A maximum output by the ohms converter of ≤ 5 V is guaranteed by a voltage divider composed of R93 and R95. Additional protection components of the ohms converter are: A) CR29 which prevents Q32 junction breakdown due to fast transients, B) CR28 which blocks negative transients that could come in via the LO terminal point and C) R91 and C27 which suppress high voltage, high frequency transients.

4-49. Degradation of accuracy in the ohms function due to changes in the ohms reference with respect to the A-D reference is minimized since both reference voltages are derived from the same +10 V reference supply. If the reference supply voltage changes, both the ohms reference and the A-D reference are affected alike and any change is effectively cancelled.

4-50. AC-to-DC Converter.

4-51. The AC-to-DC converter is an average responding ac converter. It has a bandwidth of 40 Hz to 20 kHz. The converter is composed of two stages (see Figure 7-2). The first stage, U19, is an impedance converter. The purpose of this amplifier is to provide a high impedance to the input so loading of the input signal does not occur. It also provides high drive capability for the ac converter stage, U18. The input of the impedance converter is protected against large voltage swings by diodes CR35 and CR37. Voltages in excess of +10 V or -7 V peak ac will forward bias these diodes, returning excess current to the power supply.

4-52. The impedance converter, U19, has a selection of three gains; the 200 mV, .2 mA, 200 Ω and 20 V, 20 mA, 20 k Ω ranges select a gain of 10. The ac current function selects a gain of 9.964, while the remainder of the ranges and functions select a gain of unity (see U19 Gain Table, Figure 7-2).

4-53. The second stage of the AC-to-DC converter is the ac converter, U18. A basic diagram of this stage is shown in Figure 4-6. The amplifier has three feedback loops. These loops are the ac negative feedback loop, the dc negative feedback loop, and the positive feedback loop. The ac negative feedback loop is divided into two branches; one branch for the positive half cycle and the second branch for the negative half cycle. Diodes CR33 and CR34 switch

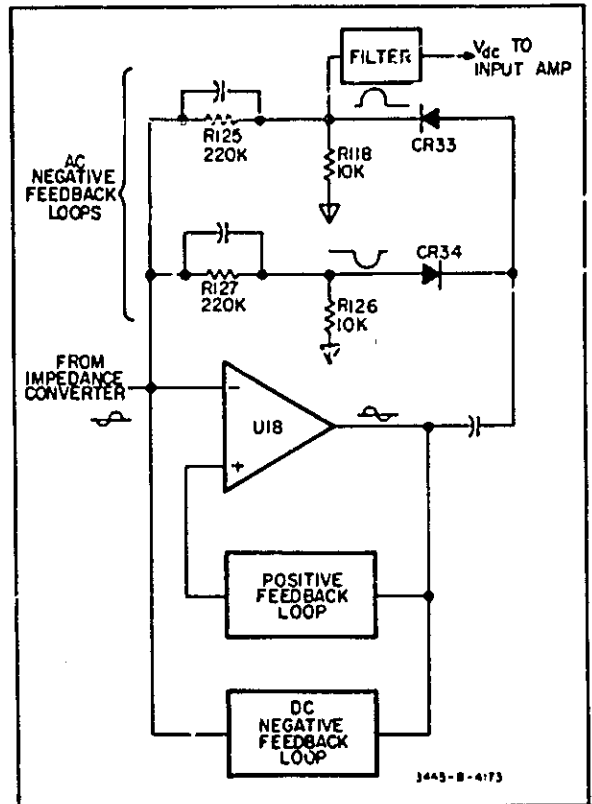

Figure 4-6. Basic Diagram, AC Converter Amplifier.

between the positive and negative half-cycles to introduce the correct loop for its respective half-cycle.

4-54. During switching of the diodes, little negative feedback is present. During the switching transition, the positive feedback loop (C45, R120 and R123) boosts the amplifier gain. This boost in gain speeds the switching transition of the diodes which gives a good frequency response at low signal levels. Once the switching transition has occurred, negative feedback is again present. The negative feedback overrides the effects of the positive feedback loop at all times other than the diode switching transition period.

4-55. The output of the AC-to-DC converter is derived from the positive half-cycle, negative feedback loop. The positive half-cycle developed across the load resistor R118 is the half-wave rectified signal of the ac converter amplifier output. This rectified signal is filtered to provide the dc output that is applied to the input amplifier during the run-up interval of the measurement sequence. For full-scale inputs, the AC-to-DC Converter output is 1.6 V dc. This output is kept relatively free of the dc offset present on the inverting input of U18 (pin 2) by the voltage divider R125 and R118. The portion of the offset appearing across the load resistor R118 is attenuated by a factor of 23.

4-56. A-D Conversion Using a Monopolar Reference.

4-57. Before proceeding with this discussion, review the

A-D converter description of the integrator, slope amplifier and auto-zero circuit in the simplified theory. Figure 4-7, Functional Diagram, A-D Converter, illustrates these circuits in relation to the monopolar reference supply, the

input amplifier and the comparator. It also illustrates the integrator output and the four control state signals, IZ, IO, I1 and I2, with respect to the measurement sequence intervals.

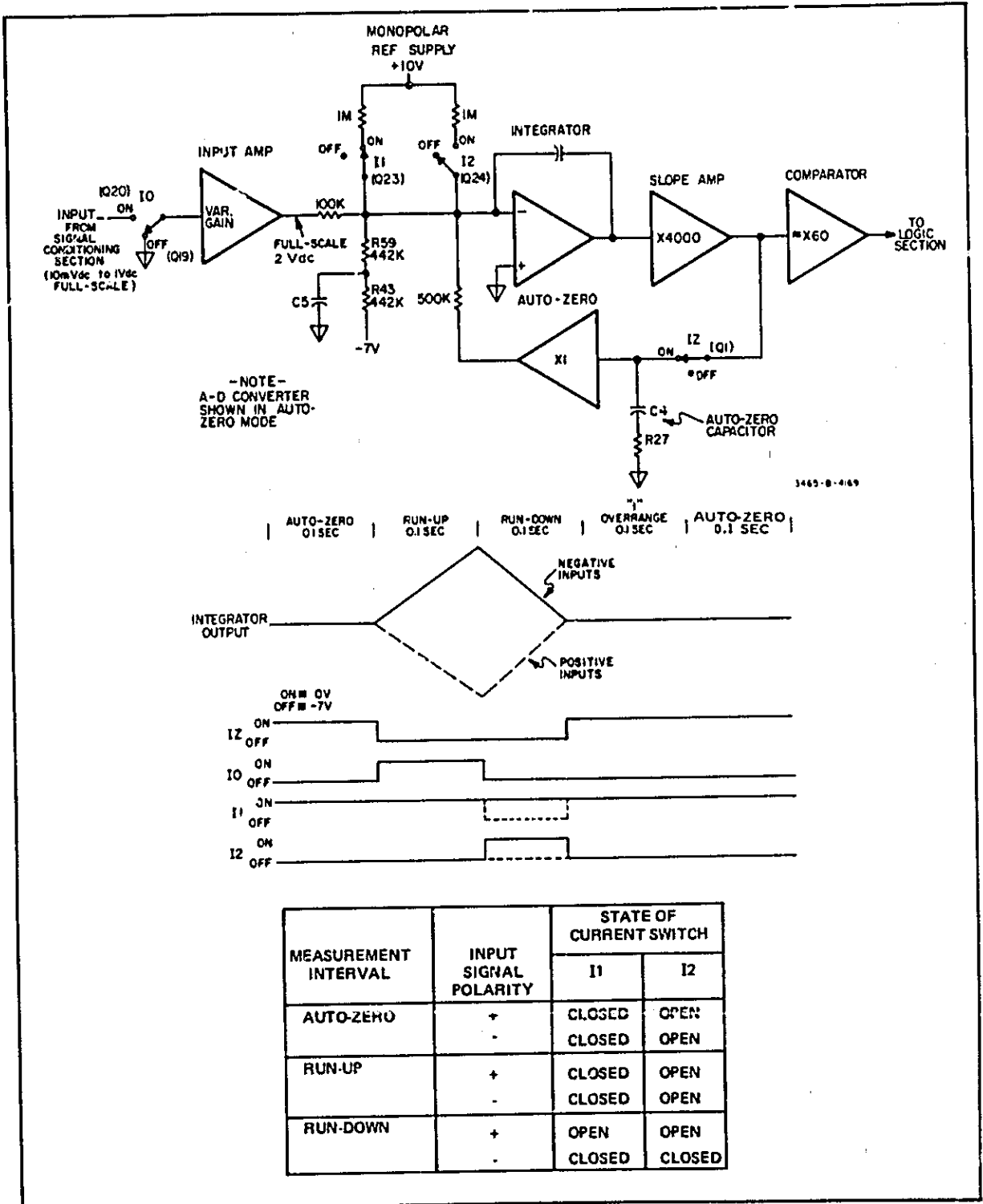

Figure 4-7. Functional Diagram, A-D Converter.

4-58. The A-D converter of Figure 4-7 is shown in the auto-zero mode. The input amplifier is grounded at the input, control state switch I1 is closed, I2 is open and the auto-zero loop is closed. Note that the auto-zero loop does not include the input amplifier but is connected to the integrator summing junction (integrator inverting input). Also connected to the summing junction are the input amplifier output, two current paths from the monopolar reference supply and the -7 V supply through R59 and R43.

4-59. The auto-zero loop uses a current balancing technique at the integrator summing junction to establish the reference. The basic principle is that the algebraic sum of currents at the integrator summing junction must be equal to zero. When the sum is zero, the output of the integrator will not change. If the sum is not zero, the integrator will ramp up for a negative current or ramp down for a positive current because of the inverting input.

4-60. When the auto-zero loop is closed, the currents summed at the integrator summing junction come from four sources; 1) the output of the input amplifier with its input grounded, 2) one current path of the monopolar reference supply (switch I1 closed), 3) the -7 V supply through R43 and R59 and 4) the auto-zero loop. The input amplifier output is the analog offset of this amplifier. The current due to the -7 V supply is roughly the negative of the current from the monopolar reference supply. The auto-zero loop then stores a voltage on the auto-zero capacitor that produces a current through R28 and R42 of the correct magnitude to force the summation of currents at the integrator summing junction to zero. Forcing the summation of currents to zero compensates for the analog offset of the input amplifier and integrator.

4-61. During the run-up interval, the auto-zero loop is opened by control state switch I2. The voltage stored on the auto-zero capacitor is still applied to the integrator summing junction and the summation of currents remains zero. At the time the auto-zero loop is opened, the output of the signal conditioning section is switched to the input amplifier by control state signal IO. The output of the input amplifier causes the algebraic summation of currents at the integrator summing junction to deviate from zero. This causes the integrator to run-up.

4-62. At the end of the run-up interval, the input amplifier is switched back to ground by control state signal IO. The summation of currents at the integrator summing junction is again zero and if no other action were taken, the integrator output would not change. The integrator output is positive at the end of run-up for negative inputs and negative for positive inputs. At the end of the run-up interval, the polarity of the integrator output is determined by the logic section. This also identifies the polarity of the input signal.

4-63. At the beginning of the run-down interval, the logic section selects the appropriate reference to return the

integrator output to zero. Run-down uses the summation of currents principle at the summing junction of the integrator. The two current paths (I1 and I2) of the monopolar reference supply provide the means of changing the summation of the currents. The summation of currents at the summing junction can be made negative by opening switch I1 and removing this current flow to the junction. The summation can be made positive by closing switch I2 in addition to I1, and providing twice the current from the monopolar reference supply. Opening switch I1 with I2 open, runs the integrator up which is required for positive inputs (see Figure 4-7). Closing I1 and I2 runs the integrator down which is required for negative inputs. The time required for the integrator to reach zero-detect during the run-down interval is proportional to the input voltage which caused run-up and determines the display.

4-64. Data Accumulator.

4-65. Refer to Figure 4-8, Data Accumulator Diagram, for this discussion. The data accumulator processes the logic signals from the logic section and provides the BCD output and the scan signals that determine the display. The data accumulator consists of a counter, data latches, a multiplexer, digit select decoder and output buffers. At the beginning of the measurement, the reset signal (RESET) goes to a logic 0 to initialize the counter and digit select decoder. At the beginning of the run-down interval of the measurement sequence, the counter begins to accumulate a count proportional to the run-down time.

4-66. The counter consists of four divide by 10 circuits. The output of each circuit is a BCD number representing one digit of the input signal. At the end of the run-down interval, the transfer signal (TXFR) is set to a logic 0. This stores the counter outputs in the data latches.

4-67. The scan signal will gate each BCD signal from the latches, beginning with the most significant digit first, through the multiplexer to the output. At the same time that the scan gates the digits through the multiplexer, the gating signal is output to the display as a digit activation pulse.

4-68. The BCD output of the multiplexer is applied to the display section (see Figure 7-4). The BCD is applied to quad NAND gates in the display section where the BCD logic is converted to BCD logic. The BCD is applied to the seven segment decoder where it is transformed to a seven bit binary number and applied to each numeral in the display. As the digit activation pulse from the data accumulator sequentially activates each numeral from most significant to least significant, the seven bit binary data will be displayed.

4-69. Display.

4-70. Refer to Figure 7-4 for this discussion. The display segments are powered by a +3 V supply. This voltage is

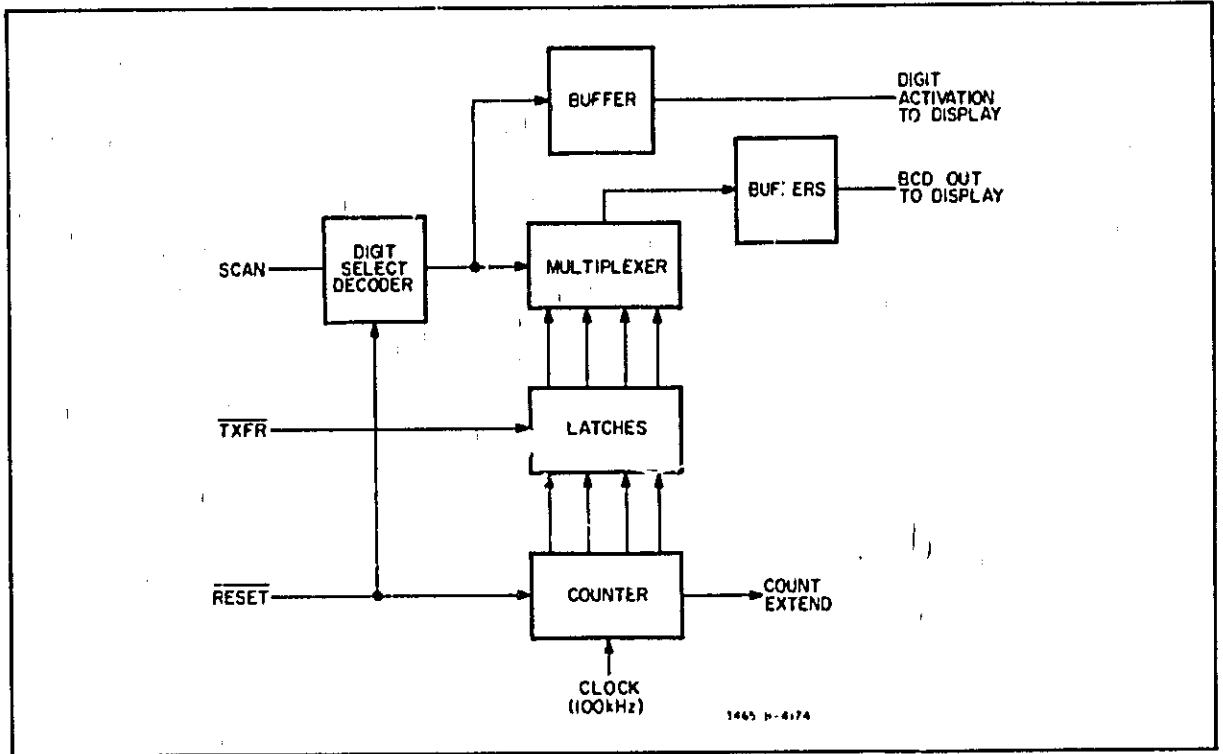

Figure 4-8. Data Accumulator.

derived from V_B and the + 11 V output of the power supply. A series voltage regulator, Q21, Q22 and Q23 maintains the + 3 V output constant. This provides constant display intensity for changes in the magnitude of V_B due to battery life and results in low power consumption

for a high V_B (new or recharged batteries).

4-71. Twenty-five connections interface the display and the main assembly. Table 4-1 indicates each terminal and the source of the signal from the main assembly.

Table 4-1. Display Interface Connections.

CONNECTION DESIGNATION	SOURCE OF SIGNAL	
DIGIT STROBES: MSD, 2MSD, 3MSD, LSD BCD: 1, 2, 4, 8	DATA ACCUMULATOR (A1U11)	
DECIMAL POINT: A, B, C, D	RANGE SWITCHES	
POLARITY ENABLE: \overline{PE}	FUNCTION SWITCHES	
POLARITY: PL	A1U4	LOGIC SECTION
OVERRANGE: OR OVERLOAD: OL	A1U5	
TRANSFER: \overline{TR}	A1U6	
+ V_p , + 11 V, GND, - 7 V	POWER SUPPLY	
PIN 25	NO CONNECTION	

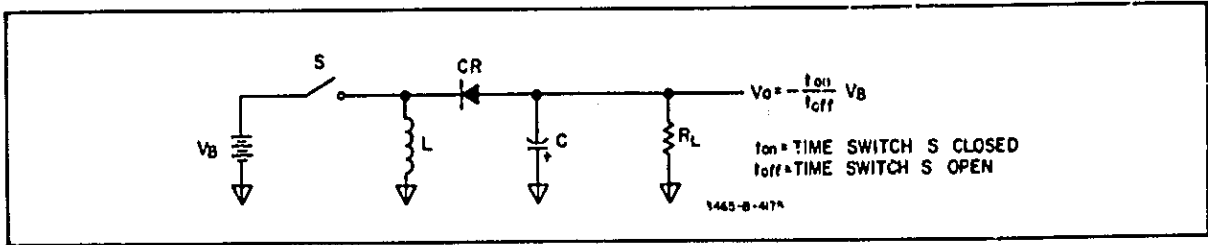

Figure 4-9. Basic Diagram, DC-to-DC Converter.

4-72. Power Supply.

4-73. The method by which a dc-to-dc converter produces a negative output voltage from a positive source voltage can be explained with the aid of Figure 4-9. The switch S opens and closes with a given duty cycle. For steady-state conditions, the output voltage will be related to the duty cycle of the switch by:

$$V_O = -\frac{t_{on}}{t_{off}} V_B$$

t_{on} = time switch S is closed
 t_{off} = time switch S is open
 Duty cycle = $\frac{t_{on}}{t_{on} + t_{off}}$

Changes in input voltage V_B can be compensated for by varying the duty cycle of the switch. This is what is done in a dc-to-dc converter. When the switch is closed during t_{on} , diode CR is reverse biased by the negative voltage on its anode and the positive voltage on its cathode; this isolates the inductor from the capacitor C and the load. The capacitor keeps the output voltage from dropping to zero during t_{on} . Closing the switch applies the battery voltage V_B across the inductor. Since the voltage across an inductor is given by $V = L \Delta i / \Delta t$, the expression for the change in inductor current is given by:

$$\Delta i = \frac{V}{L} \Delta t$$

Both V and L are fixed, so the inductor current increases linearly with time. This results in an energy transfer from the battery to the inductor. When switch S is opened during t_{off} , current flow to the inductor is shut off. Because the fundamental characteristic of an inductor is to oppose any change in current flow, the inductor generates a back emf of approximately -8 volts. This voltage forward-biases diode CR and allows the energy stored in the inductor to be transferred to the capacitor and the load.

4-74. The following paragraphs describe the operation of the actual dc-to-dc converter circuit in the 3465A, and the converter regulator. Figure 4-10 shows a simplified schematic of the -7 volt converter and regulator U17. The discussion assumes steady-state conditions, and begins with Q33 in the off state ($I_C = 0$). When Q33 first turns on, it will be in saturation (see Figure 4-11), causing the entire voltage +V_B to be dropped across the primary of the auto-transformer T1. As explained in paragraph 4-73, the collector current through the inductor begins to rise linearly with time. The constant voltage at the base of Q34 causes Q34 and R98 to provide a constant current sink for the base current of Q33. Consequently, the rising collector current of Q33 follows one of the I_b curves in Figure 4-11. Q33 will eventually come out of saturation as the collector current approaches βI_b . When Q33 comes out of saturation,

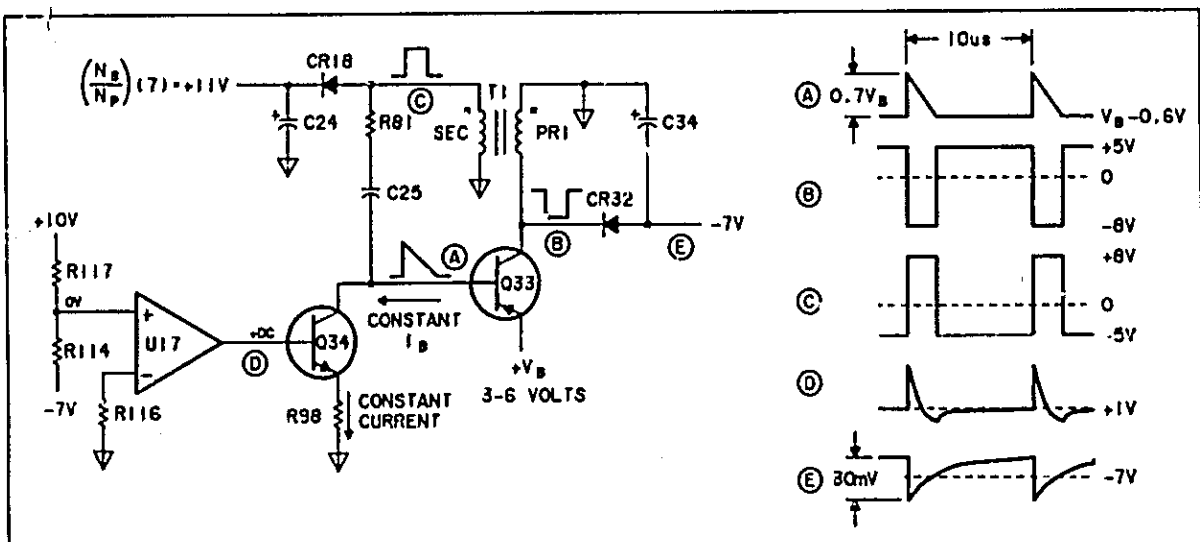

Figure 4-10. Simplified Diagram, DC-to-DC Converter.

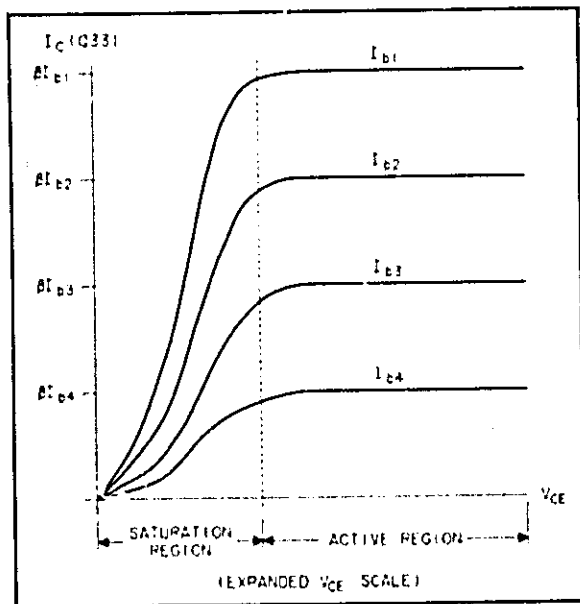

Figure 4-11. Common-Emitter Output Characteristics.

V_{ce} begins to increase, which in turn causes less voltage to be dropped across the primary of T1. The autotransformer's windings are such that the primary and induced secondary voltages are 180° out of phase. Therefore, the falling voltage across the primary causes a rising voltage across the secondary, which is coupled back to the base of Q33 by R81 and C25. When the base of Q33 goes sufficiently positive to reverse-bias the base-emitter junction, Q33 shuts off and stops delivering current to T1. The primary of T1 then generates a back emf of approximately -8 volts in an attempt to keep the inductor current from changing. This action forward biases CR32 and the energy stored in the magnetic field of the inductor is transferred to C34 and the load. The -8 volts on the primary of T1 induces $+8$ volts on the secondary winding which, when applied to the RC feedback network, causes the voltage at the base of Q33 to ramp down. When the base voltage of Q33 drops to $(V_{B-.6})$ volts, the base-emitter junction becomes forward biased, Q33 turns on, and the cycle begins again.

4-75. The secondary winding of T1 is also used to provide a $+11$ volt output, which is then further regulated by the $+10$ volt series regulator (paragraph 4-77). A positive output is developed by transformer-coupling a portion of the energy stored in the primary winding inductance through the secondary winding of T1. This output is equal to the turns-ratio times the voltage across the primary of T1 when Q33 is off.

4-76. Changes in the output voltage and in the battery voltage V_B can be regulated by varying the duty cycle of transistor switch Q33 (see paragraph 4-73). The duty cycle can be varied by controlling the voltage at the base of Q34,

which determines the base current of Q33. A larger base current will cause Q33 to take a longer time to come out of saturation (see Figure 4-11), which varies the transistor on time. The voltage at the base of Q34 is supplied by U17. The inverting input of U17 is grounded through R116, while a 10 -to- 7 voltage divider (R117 & R114) is connected to the non-inverting input. One end of the divider (R117) senses the voltage output of the $+10$ volt series regulator, while the other end (R114) senses the -7 volt output of the dc-to-dc converter. A change in voltage at the -7 volt output is sensed by the non-inverting input and is amplified by U17. The output voltage of U17, driving the base of Q34, controls the base current of Q33, and regulation of the -7 volt output is achieved. Since the $+11$ volt output is the transformer turns-ratio times the -7 volt output, the $+11$ volt supply is also regulated.

4-77. $+10$ V series Voltage Regulation.

4-78. The temperature compensated zener diode CR17 is the voltage reference from which the $+10$ V reference is derived. The zener voltage is applied to the non-inverting input of U16. A resistor divider in the precision resistor pack (R75) senses the voltage at the output. A portion of the voltage is fed to the inverting input of U16. This error voltage is amplified by U16 to drive Q26. The collector current of Q26 then provides base drive for the series pass transistor Q26. To ensure turn-on of the dc-to-dc converter, the collector, as opposed to the emitter of the series pass transistor Q27, is connected to the output. The low collector-to-emitter saturation voltage aids in the turn-on process of the converter. This ensures start-up for battery voltages as low as 2 to 3 volts. One advantage to this configuration is that the $+11$ V supply can decrease to within the collector-to-emitter saturation voltage of the $+10$ V regulated output and regulation is still maintained.

4-79. Battery Low-Voltage Detection.

4-80. Refer to the power supply schematic, Figure 7-5. The battery low-voltage detection circuit is comprised of a differential amplifier, Q36 and Q37. The voltage at the base of Q36 is set at about $+2.9$ V by the voltage divider R139 and R141. If the battery voltage ($+VB$) is greater than $+2.9$ V, Q36 conducts and Q37 is off. When the battery voltage drops below $+2.9$ V, Q37 turns on providing base drive for Q38. When Q38 is on, the base of Q34 is pulled to -7 V and Q34 turns off. This action turns the dc-to-dc converter of the power supply off removing all power supply outputs. This removes the front panel display indication. To reinstate the display, the OFF/ON switch must be turned OFF and again ON. The display indication will reappear while capacitor C51 charges to $+2.9$ V. When the voltage on C51 (which is the base voltage of Q36) exceeds the battery voltage ($+VB$), the circuit deactivates the power supply as previously described and the display indication disappears again.

WARNING

These servicing instructions are for use by qualified personnel only. To avoid electrical shock, do not perform any servicing other than that contained in the operating instructions unless you are qualified to do so.

Table 5-1. Test Equipment Required.

INSTRUMENT TYPE	REQUIRED CHARACTERISTICS	RECOMMENDED MODEL
Digital Volt/Ohmmeter	DC Volts: 1 V, 10 V and 100 V range Accuracy: $\pm 0.04\%$ Input Resistance: 10 M Ω Ohms: 200 k Ω Accuracy: $\pm 0.07\%$	-hp- 3470 System; -hp- 34702A Multimeter
Digital Voltmeter	DC Volts: 5 digit resolution to 1 μ V on 100 mV dc range. Accuracy: $\pm 0.007\%$ AC Volts: 1 V and 10 V range Frequency: 40 Hz to 20 kHz Accuracy: 0.25%	hp 3455A
AC Calibrator/ High Voltage Amplifier	Frequency: 20 Hz to 100 kHz Output: 1 mV to 1000 V Accuracy (mid band): $\pm 0.1\%$	-hp- 745A/746A
DC Standard	Output: 1 mV to 1000 V Accuracy: $\pm 0.02\%$	-hp- 740B
Meter Calibrator	Output: 1 A Accuracy: $\pm 0.1\%$	-hp- 6920B
Electronic Counter	Frequency: 50 and 60 Hz Accuracy: $\pm 0.01\%$	-hp- 5300A/5302A
Power Supply	Output: 20 V, 1 A	-hp- 6294A
Resistor Decade Box	10 Ω , 100 Ω , 1 k Ω , 10 k Ω , 100 k Ω and 1 M Ω steps Accuracy: $\pm 0.005\%$	General Radio Mdl GR 1433-Z
Capacitor	1 μ F $\pm 10\%$	0160-3407
Resistors	1 Ω $\pm 0.02\%$ 10 Ω $\pm 0.01\%$ 1 \times Ω $\pm 0.01\%$ 10 k Ω $\pm 0.01\%$ 100 k Ω $\pm 0.01\%$ 1 M Ω $\pm 0.01\%$ 10 M Ω $\pm 0.1\%$ 22 k Ω $\pm 1\%$	G.R. 1440-9601 G.R. 1440-9611 G.R. 1440-9631 G.R. 1440-9641 G.R. 1440-9651 G.R. 1440-9661 0698-8194 0757-1087

SECTION V MAINTENANCE

5-1. INTRODUCTION.

5-2. This section of the manual contains Performance Tests and Adjustment Procedures. The Performance Tests are designed to verify the critical specifications listed in Table 1-1. A Performance Test Card is at the end of this section for recording the results of the performance tests.

5-3. Test Equipment Required.

5-4. Equipment required for the performance tests and adjustment procedures is listed in Table 5-1, Recommended Test Equipment. Equipment that satisfies the critical specification given in the table may be substituted for a recommended model.

NOTE

Throughout the Performance Tests and Adjustment Procedures, the -hp- Model 3465B is referred to as Multimeter.

5-5. PERFORMANCE TESTS.

5-6. DC Voltmeter Accuracy Test.

5-7. A DC Standard is required for this test.

- a. Set the Multimeter function to DCV ($\overline{\text{---}}$ V) and range to 20 M. Short the V Ω and COM terminals together and adjust the display for 0.000, using the ZERO ADJ on the rear panel.
- b. Disconnect the short and connect the DC Standard between the V Ω and COM terminals.
- c. Check all the dc ranges listed in Table 5-2 for the tolerances indicated.

CAUTION

Do not apply more than 1000 V, otherwise damage to the instrument may result.

Table 5-2. DC Voltmeter Accuracy Test.

DC Range	DC Standard Output	Multimeter Display Limits
20 mV	± 0.00100 V ± 0.00500 V ± 0.01000 V	.998 – 1.002 mV 4.996 – 5.004 mV 9.995 – 10.005 mV
200 mV	± 0.01000 V ± 0.05000 V ± 0.10000 V	9.99 – 10.01 mV 49.98 – 50.02 mV 99.97 – 100.03 mV
2 V	± 0.10000 V ± 0.50000 V ± 1.00000 V	.9999 – 1.0001 V 4.998 – 5.002 V 9.997 – 10.003 V
20 V	± 1.00000 V ± 5.00000 V ± 10.0000 V	.999 – 1.001 V 4.998 – 5.002 V 9.997 – 10.003 V
200 V	± 10.0000 V ± 50.0000 V ± 100.000 V	9.99 – 10.01 V 49.98 – 50.02 V 99.97 – 100.03 V
1000 V	± 100.000 V ± 500.000 V ± 1000.00 V	99.8 – 100.2 V 499.7 – 500.3 V 999.6 – 1000.4 V

5-8. DC Ammeter Accuracy Test.

5-9. This test requires the use of a power supply, a DC Differential Voltmeter and a precision resistor listed in Table 5-3 (part numbers are given in Table 5-1) or a resistor decade box.

- a. Connect the Multimeter and test equipment as shown in Figure 5-1.

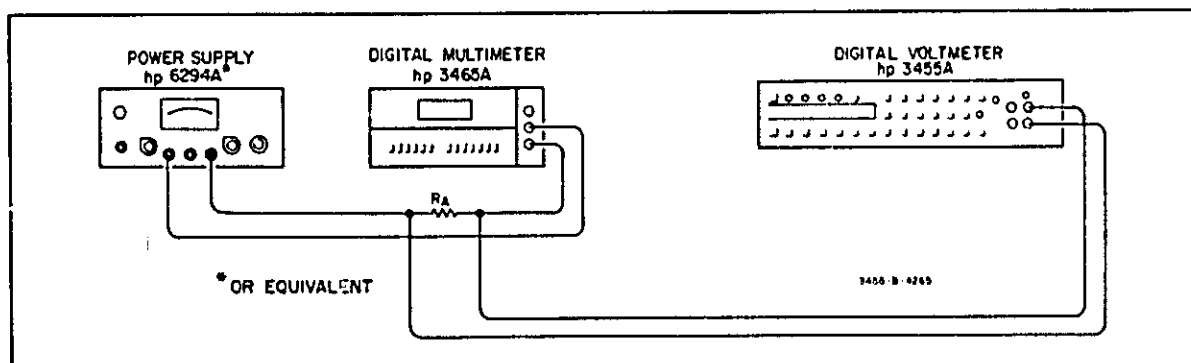

Figure 5-1. DC Ammeter Accuracy Test.

Table 5-3. DC Ammeter Accuracy Test.

Multimeter Range	Current Level	R _A	3455A VM Reading	Multimeter Display Limits
200 μ A	10 μ A	100 k Ω \pm 0.01%	1.0000 V	9.98 - 10.02 μ A
	50 μ A		5.0000 V	49.95 - 50.05 μ A
	100 μ A		10.000 V	99.92 - 100.06 μ A
2 mA	.1 mA	1 k Ω \pm 0.01%	.10000 V	.0998 - .1002 mA
	.5 mA		.50000 V	.4995 - .5005 mA
	1 mA		1.0000 V	.9992 - 1.0006 mA
20 mA	1 mA	1 k Ω \pm 0.01%	1.0000 V	.998 - 1.002 mA
	5 mA		5.0000 V	4.993 - 5.007 mA
	10 mA		10.000 V	9.988 - 10.012 mA
200 mA	10 mA	10 Ω \pm 0.01%	.10000 V	9.93 - 10.07 mA
	50 mA		.5000 V	49.69 - 50.31 mA
	100 mA		1.0000 V	99.39 - 100.61 mA
2000 mA	100 mA	1 Ω \pm 0.02%	.10000 V	99.3 - 100.7 mA
	500 mA		.50000 V	496.9 - 503.1 mA
	1000 mA		1.0000 V	993.9 - 1006.1 mA

b. Connect the 100 kilohm \pm 0.01% resistor in the R_A position as shown.

c. Set the Multimeter function to DCA ($\overline{\text{---}}\text{A}$) and range to 200 μ A. Adjust the power supply output for a 3455A Voltmeter reading of 1.000 V. The Multimeter should indicate 9.98 to 10.02 μ A.

d. Check all the Multimeter ranges, using the values of R_A and 3455A Voltmeter readings shown in Table 5-3. The Multimeter display should indicate within the limits provided.

5-10. Ohms Accuracy Test.

5-11. A precision resistive decade box will be required for this test. It should be calibrated and have a known accuracy of .005%.

a. Connect the equipment as shown in Figure 5-2.

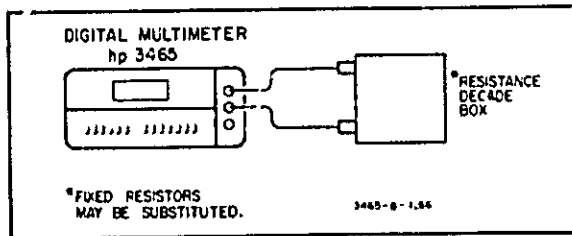

Figure 5-2. Ohms Accuracy Test.

b. Set the Multimeter function to OHMS (Ω) and check all the ranges in Table 5-4 using the decade box to supply the indicated resistances. The Multimeter display should indicate within the limits provided.

5-12. AC Voltage Accuracy Test.

5-13. An AC Calibrator and High Voltage Amplifier will be required for the following tests.

Table 5-4. Ohms Accuracy Test.

Multimeter Range	Resistive Set	Multimeter Display Limits
200 Ω	10 Ω	9.98 - 10.02 Ω
	50 Ω	49.97 - 50.03 Ω
	100 Ω	99.96 - 100.04 Ω
2 k Ω	100 Ω	.9999 - 1.0001 k Ω
	500 Ω	.4998 - .5002 k Ω
	1 k Ω	.9997 - 1.0003 k Ω
20 k Ω	1 k Ω	.999 - 1.001 k Ω
	5 k Ω	4.998 - 5.002 k Ω
	10 k Ω	9.997 - 10.003 k Ω
200 k Ω	10 k Ω	9.99 - 10.01 k Ω
	50 k Ω	49.98 - 50.02 k Ω
	100 k Ω	99.97 - 100.03 k Ω
2000 k Ω	100 k Ω	99.9 - 100.1 k Ω
	500 k Ω	499.8 - 500.2 k Ω
	1000 k Ω	999.7 - 1000.3 k Ω
20 M	1 M Ω	.995 - 1.005 M Ω
	5 M Ω	4.994 - 5.006 M Ω
	10 M Ω	9.989 - 10.011 M Ω

a. Set the Multimeter function to ACV (\sim V). Connect the AC Calibrator between the V Ω terminal and COM terminal. Be sure to connect the Calibrator sense leads.

b. Check the voltage ranges listed in Table 5-5 at each frequency listed. The Multimeter should indicate within the limits provided.

5-14. AC Ammeter Accuracy Test.

5-15. An AC Calibrator, a 3455A Digital Voltmeter and discrete resistors (R_A) indicated in Table 5-6 are required for this test. Even through less accurate resistance values are required for this test, it is expedient to use the resistors specified in Table 5-1.

a. Set the Multimeter function to ACA (\sim A) and range to 200 μ A. Connect the equipment as shown in Figure 5-3 using a discrete resistor for R_A. (To select R_A, note the

Table 5-5. AC Voltage Accuracy Test.

Multimeter Range	AC Standard Output	Test Frequency	Multimeter Display Limits
200 mV	10 mV 50 mV 100 mV	40 Hz, 400 Hz, 10 kHz	9.93 – 10.07 mV
		40 Hz, 1 kHz, 10 kHz	49.87 – 50.13 mV
		40 Hz, 5 kHz, 10 kHz	99.80 – 100.20 mV
	10 mV 50 mV 100 mV	11 kHz, 15 kHz, 20 kHz	9.80 – 10.20 mV
		11 kHz, 15 kHz, 20 kHz	49.60 – 50.40 mV
		11 kHz, 15 kHz, 20 kHz	99.35 – 100.65 mV
2 V	100 mV 500 mV 1 V	40 Hz, 400 Hz, 10 kHz	.0993 – .1007 V
		40 Hz, 1 kHz, 10 kHz	.4987 – .5013 V
		40 Hz, 5 kHz, 10 kHz	.9980 – 1.0020 V
	100 mV 500 mV 1 V	11 kHz, 15 kHz, 20 kHz	.0980 – .1020 V
		11 kHz, 15 kHz, 20 kHz	.4960 – .5040 V
		11 kHz, 15 kHz, 20 kHz	.9960 – 1.0065 V
20 V	1 V 5 V 10 V	40 Hz, 400 Hz, 10 kHz	.993 – 1.007 V
		40 Hz, 1 kHz, 10 kHz	4.987 – 5.013 V
		40 Hz, 5 kHz, 10 kHz	9.980 – 10.020 V
	1 V 5 V 10 V	11 kHz, 15 kHz, 20 kHz	.980 – 1.020 V
		11 kHz, 15 kHz, 20 kHz	4.960 – 5.040 V
		11 kHz, 15 kHz, 20 kHz	9.935 – 10.065 V
200 V	10 V 50 V 100 V	40 Hz, 400 Hz, 10 kHz	9.99 – 10.07 V
		40 Hz, 1 kHz, 10 kHz	49.87 – 50.13 V
		40 Hz, 5 kHz, 10 kHz	99.80 – 100.20 V
	10 V 50 V 100 V	11 kHz, 15 kHz, 20 kHz	9.80 – 10.20 V
		11 kHz, 15 kHz, 20 kHz	49.60 – 50.40 V
		11 kHz, 15 kHz, 20 kHz	99.35 – 100.65 V
500 V	100 V 500 V	40 Hz, 400 Hz, 1 kHz	99.3 – 100.7 V
		40 Hz, 400 Hz, 1 kHz	493.7 – 501.3 V
	100 V 500 V	1.5 kHz, 2 kHz	99.0 – 101.0 V
		1.5 kHz, 2 kHz	497.0 – 503.0 V

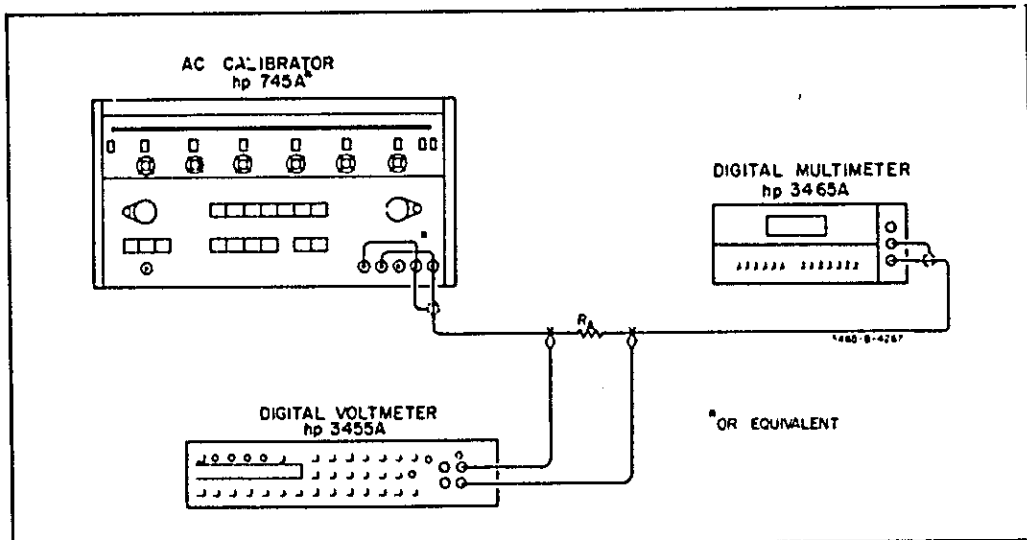

Figure 5-3. AC Ammeter Accuracy Test 200 μ A Through 20 mA Range.

value of R_A as directed in Table 5-6 and install the part number indicated in Table 5-1. A resistor decade box *WILL NOT* provide the accuracy required of R_A because of the introduction of wire-wound resistor inductance by the decade box).

- b. Set the AC Calibrator frequency to the desired test frequency indicated in Table 5-6.
- c. Adjust the AC Calibrator amplitude for a 3455A Digital Voltmeter display as indicated in Table 5-6 for the range and current level being tested.
- d. REMOVE the 3455A Digital Voltmeter from the test setup.
- e. Verify the Multimeter Display Limits as indicated in the last column of Table 5-6.
- f. Reconnect the 3455A Digital Voltmeter as shown in Figure 5-3.
- g. Repeat Steps b through f for each frequency, range and current level listed in Table 5-6. Change R_A as indicated for each current level.

NOTE

The procedures up to this point have verified the accuracy of all circuitry associated with the ac current ranges, except the 200 mA and 2 A shunts and their associated wiring. Even though the following steps do not check these shunts over the 40 Hz to 1 kHz frequency range, it is considered adequate. An alternate procedure is offered to cover the full current-frequency combination.

h. To check the 200 mA and 2 A ranges, it is necessary to use an ac current source capable of these current outputs such as the 6920B Meter Calibrator. Set the 6920B OUTPUT switch to OFF and replace the AC Calibrator with the 6920B.

i. Set the 6920B FUNCTION switch to AC and RANGE switch to 100 milliamperes. Adjust the digital potentiometer readout control to provide a 10 mA output.

j. Set the OUTPUT SWITCH to ON HOLD. Verify Multimeter Display Limits shown in Table 5-7.

k. Return the 6920B OUTPUT SWITCH to OFF before changing ranges. Adjust the 6920B for the 100 mA range outputs listed in Table 5-7 and verify the Multimeter Display Limits.

l. Change Multimeter range to 2000 mA and verify Multimeter Display Limit for the 100 mA input.

m. With the 6920B OUTPUT switch at OFF, change the 6920B range to 1A. Check the Multimeter Display Limits for the 500 mA and 1000 mA inputs indicated in Table 5-7.

5-16. Alternate AC Ammeter Accuracy Test (200 mA/2000 mA, 40 Hz to 1 kHz).

5-17. Hewlett-Packard Models 201C, 6825A, 3455A and precision discreet resistors are required for this test.

NOTE

A 0.1 Ω (100 m Ω) resistor is used as the current sensor. Inaccuracies may be introduced due to contact resistances. Due precautions must be exercised to attain required accuracies.

Table 5-6. AC Ammeter Accuracy Test (200 μ A Through 20 mA).

Frequency	Range	Current Level	R_A	3455A Reading	ACA (\sim A) Display Limits
100 Hz	200 μ A	10 μ A 199 μ A	100 k Ω 100 k Ω	1.0000 V 19.900 V	9.91 - 10.09 μ A 198.25 - 199.85 μ A
1 kHz	2 mA	.1 mA 1.99 mA	1 k Ω 1 k Ω	.10000 V 1.9900 V	.0991 - .1009 mA 1.9825 - 1.9985 mA
1 kHz	20 mA	1 mA 19.9 mA	1 k Ω 1 k Ω	2.0000 V 19.900 V	.992 - 1.008 mA 19.825 - 19.985 mA

Table 5-7. AC Ammeter Accuracy Test, 200 mA and 2000 mA Ranges.

Multimeter Range	Output Meter Calibration	Multimeter Display Limits
200 mA	10 mA	9.87 - 10.13 mA
	50 mA	49.55 - 50.45 mA
	100 mA	99.15 - 100.85 mA
2000 mA	100 mA	98.7 - 101.3 mA
	500 mA	495.5 - 504.5 mA
	1000 mA	991.5 - 1008.5 mA

Table 5-8. Alternate AC Ammeter Accuracy Test 200 mA and 2000 mA Ranges.

Test Frequencies (Hz)	Multimeter Range (mA)	hp-3455A Reading (V)	Multimeter Display Limits
40 400 4000	200	0.00100	9.87 - 10.13
		0.00500	49.55 - 50.45
		0.01000	99.15 - 100.85
	2000	0.01000	98.7 - 101.3
		0.05000	495.5 - 504.5
		0.10000	991.5 - 1008.5

- Connect the equipment as shown in Figure 5-4.
- Set -hp- Model 6825A to amplifier mode and gain to X4.
- Set the Multimeter FUNCTION to ac amps (~A) and range to 200 mA.

5-18. Refer to Table 5-8 for the following steps.

- Set -hp- Model 201C to the desired test frequency indicated.
- Adjust -hp- Model 201C amplitude for the 3455A reading indicated.
- Verify that the Multimeter display is within limits indicated.
- Repeat Step c (Paragraph 5-17) and Steps a through c (Paragraph 5-18) for each frequency and range indicated.

5-19. AC Normal Mode Rejection Test.

5-20. AC normal-mode rejection is the ratio of the peak

normal-mode voltage to the resultant error in reading.

$$NMR_{(db)} = 20 \log_{10} \frac{\text{Peak ac superimposed voltage}}{\text{Effect on reading (peak volts)}}$$

An AC Calibrator, an Electronic Counter, a 1 μF capacitor (-hp- Part No. 0160-3407) and a 22 kΩ resistor (-hp- Part No. 0757-1087) are required for this test.

- Connect the test equipment as shown in Figure 5-5. Do not connect the Multimeter at this time.
- Using the Electronic Counter as a monitor, adjust the AC Calibrator frequency to 60 Hz ± 0.1%.
- Set the Multimeter function to DCV (≡V) and range to 20 V. Short the Multimeter input and note the indication.
- Disconnect the short and connect the AC Calibrator to the Multimeter input. Adjust the Calibrator output to 7.07 V rms (10 V peak).
- The Multimeter indication should not vary more than .007 V from the indication noted in Step C. This verifies a normal-mode rejection of greater than 60 dB.

f. Change the AC Calibrator frequency to 1592 Hz. The Multimeter display should indicate .7071 to 1.0000 verifying a shunt capacitance less than 100 pF.

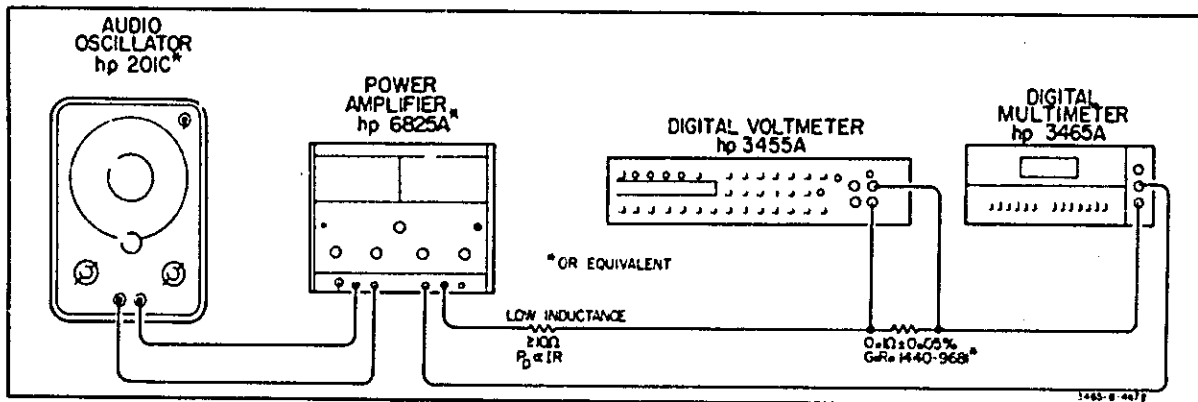

Figure 5-4. AC Ammeter Accuracy Test 200 mA and 2000 mA.

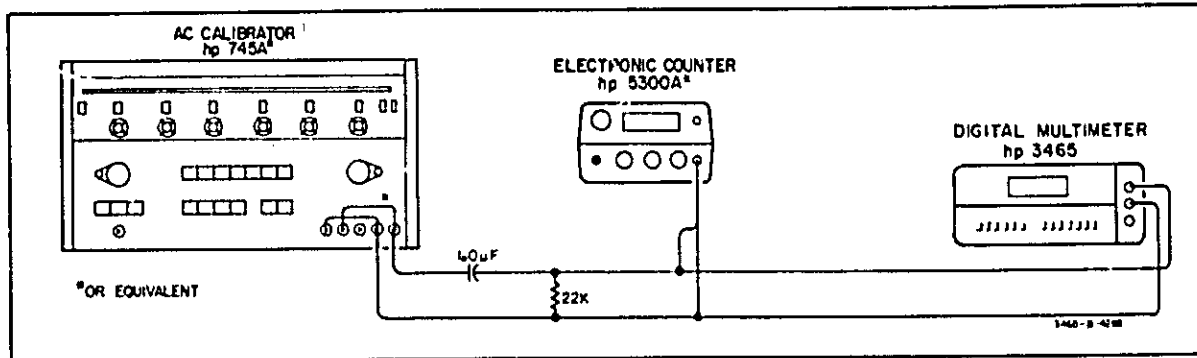

Figure 5-5. AC Normal-Mode Rejection Test.

5-21. AC Effective Common-Mode Rejection Test.

5-22. An AC Calibrator, an Electronic Counter, and a 1 kΩ ± 1% resistor are required for this test.

- a. Connect a 1 kΩ resistor between the VΩ and COM terminals.
- b. Set the Multimeter function to DCV (≡≡≡ V) and range to 20 mV. Note the Multimeter indication.
- c. Connect the AC Calibrator to the Multimeter as shown in Figure 5-6.
- d. Using the Electronic Counter as a monitor, set the AC Calibrator frequency to 60 Hz ± 0.1% (50 Hz ± 0.1% if operating Multimeter from a 50 Hz source).
- e. Adjust the Calibrator output to 7.07 V rms (10 V peak).
- f. Note the Multimeter indication. The reading should not vary more than 10 microvolts from the reading noted in Step b verifying an ac common-mode rejection of greater than 120 dB.

5-23. DC Voltmeter Input Resistance Test

5-24. A DC Standard and a 10 MΩ ± 0.1% resistor (or equivalent) are required for this test.

- a. Connect the Multimeter, DC Standard and resistor as shown in Figure 5-7.

- b. Set the Multimeter function to DCV (≡≡≡ V) and range to 20 V.

- c. Connect a jumper across the 10 MΩ resistor and adjust the DC Standard to provide a Multimeter display of +10.000.

- d. Remove the jumper from the 10 MΩ resistor. The Multimeter display should indicate 4.975 to 5.025 verifying an input resistance of 10 MΩ ± 1% on the 20 V through 1000 V ranges.

- e. Change the DC Standard output to 0 V and change the Multimeter range to 2 V.

- f. Connect a jumper across the 10 MΩ resistor and adjust the DC Standard to provide a Multimeter display of +1.0000.

- g. Remove the jumper from the 10 MΩ resistor. The Multimeter display should indicate .9990 or greater verifying an input resistance of ≥ 10¹⁰ on the 20 mV through 2 V ranges.

5-25. AC Voltmeter Input Impedance Test.

5-26. An AC Calibrator and a 1 MΩ ± 0.1% resistor (or equivalent) are required for this test.

- a. Connect the AC Calibrator and a 1 MΩ resistor as shown in Figure 5-8. Connect a jumper across the resistor.

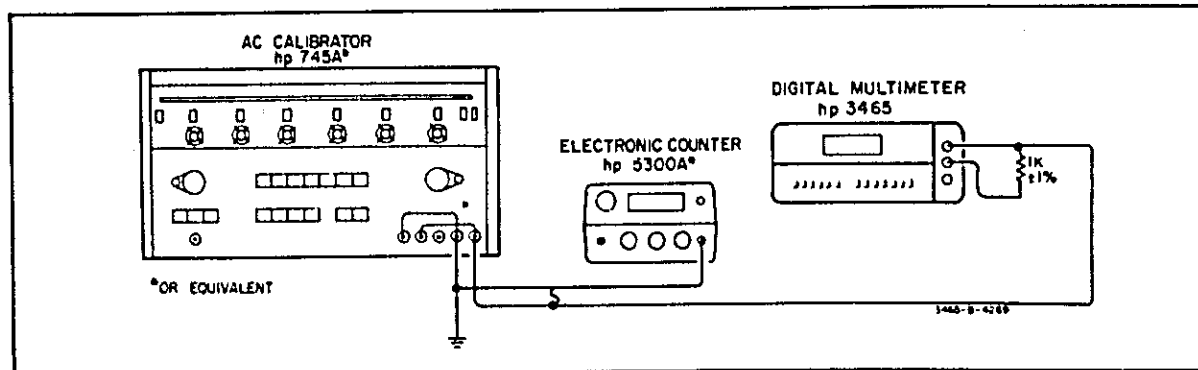

Figure 5-6. AC Effective Common-Mode Rejection Test.

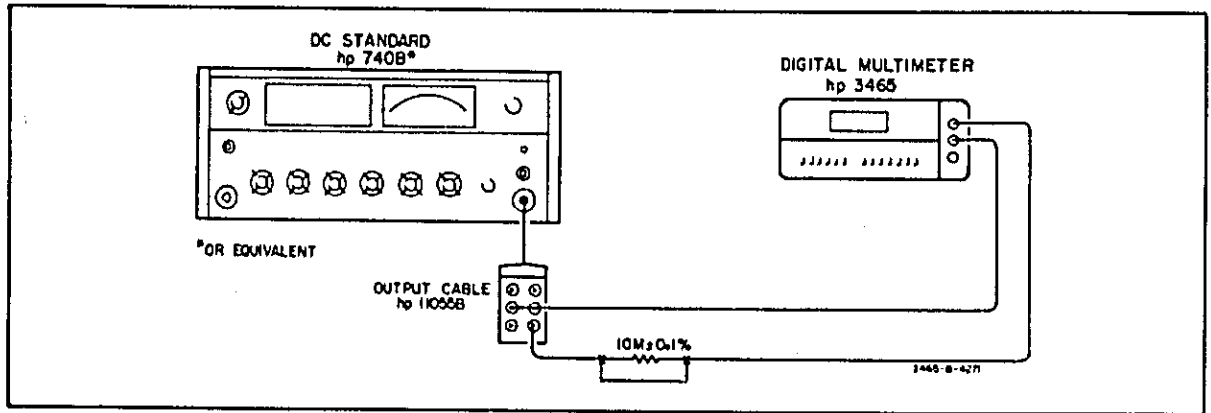

Figure 5-7. DC Voltmeter Input Resistance Test.

- b. Set the Multimeter function to ACV (\sim V) and range to 2 V.
- c. Set the AC Calibrator frequency to 40 Hz and adjust the output amplitude for a Multimeter display of 1.0000.
- d. Remove the jumper from the 1 M Ω resistor. The Multimeter display should indicate .4975 to .5025 verifying

an input impedance resistive component of 1 M Ω \pm 1%.

- e. Maintain the AC Calibrator at 40 Hz and adjust the output amplitude for a Multimeter display of 1.0000.

- f. Change the AC Calibrator frequency to 1592 Hz. The Multimeter display should indicate .7071 to 1.0000 verifying a shunt capacitance less than 100 pF.

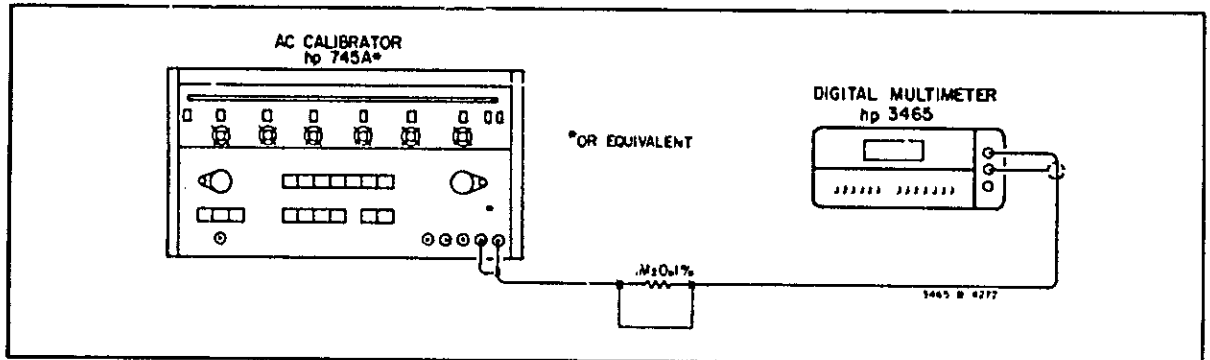

Figure 5-8. AC Voltmeter Input Impedance Test.

ADJUSTMENT PROCEDURES

5-27. ADJUSTMENT PROCEDURES.

WARNING

Adjustment Procedures of Section V are intended for qualified service personnel only. To reduce the possibility of electrical shock, only qualified personnel are to perform maintenance duties.

5-28. The following procedures should be performed only after it has been determined from Performance Tests that the Multimeter does not meet specifications. If any adjustment in these procedures cannot be made, refer to

the troubleshooting procedures of Section VII. Location of the Multimeter adjustments is shown in Figure 5-9. Test equipment to be used for adjustments are as specified in Table 5-1.

5-29. Disassembly Procedure.

- a. Turn the Multimeter off and disconnect the ac power.
- b. Remove four screws from the bottom shell.
- c. Place the Multimeter right-side up with the front panel facing to your left.

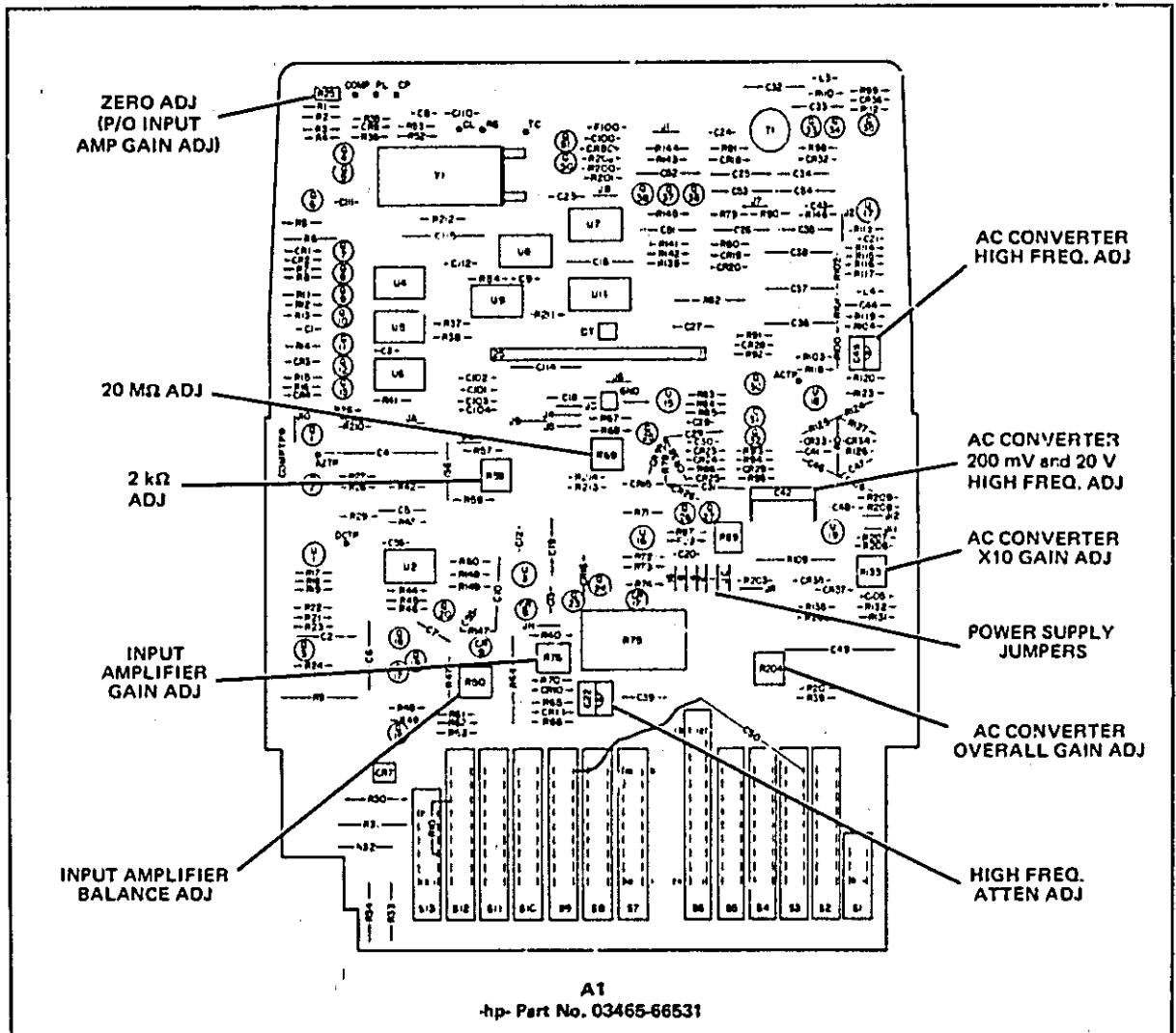

Figure 5-9. Multimeter Adjustment Location.

- d. Remove top shell and disconnect power supply cable (red/black).
- e. Disconnect the A2 pc assembly from the A1 pc assembly and fold over the front panel. Do not disconnect the ribbon cable.
- f. Remove four spacers.
- g. Remove one screw in the center of the A1 pc assembly.
- h. Reconnect the A2 pc assembly to the A1 pc assembly.
- i. Invert the Multimeter so that it rests on the front panel and the A2 pc assembly.
- j. Remove the bottom shell.
- k. Reconnect the Power Supply cable and the ac power.

NOTE

After use of a soldering iron, flux remover or freon on the A1 Assembly, allow 10 to 15 minutes for the instrument to thermally stabilize before an adjustment is performed. If cleaning solvents or flux removers are used, they must be residue-free or be rinsed away. Residues on the instrument surfaces may cause instabilities or inaccuracies.

5-30. Power Supply Adjustment.

5-31. Power Supply + 10 V Reference Voltage Adjustment. Coarse adjustment of the + 10 V reference voltage is made by selecting the proper combination of power supply jumpers designated 1, 2, 4, 8 and 16. Coarse adjustment is necessary whenever the + 10 V reference cannot be adjusted with A1R89 and Jumper JR(+ 10 V ADJ - fine adjustment) to obtain a display of 1.0000 for a 1 V dc input. This can occur after replacement of A1CR17, A1R75 or A1U16 or because of the long-term drift of the A1CR17 zener voltage.

5-32. Power supply jumpers 1, 2, 4, 8 and 16 parallel resistors in A1R75 which are used as a regulator feedback network. Removing a jumper decreases the + 10 V reference voltage and results in an increase in the Multimeter display for a given input.

5-33. A DC Standard is required for this adjustment.

- a. Set Multimeter function to DCV (==== V) and range to 2 V.
- b. Apply + 1 V dc from the DC Standard between the V Ω and COM terminals.

- c. Note and record the Multimeter display.

d. Refer to Table 5-9, Power Supply Jumpers. Locate the line with LO and HI reading limits that bound the Multimeter display recorded and note the jumper combination. (If reading is out of range on table, check A1CR17 for $6.95 \text{ V} \pm 0.25 \text{ V}$, A1R75 and A1U16).

e. A "0" means to remove jumper; a "1" means leave jumper in place. Introduce the jumper combination noted in Step 3.

f. Adjust A1R89 (+ 10 V ADJ) for a Multimeter display of $+ 1.0000 \pm 2$ counts. If the adjustment range of A1R89 is insufficient, remove jumper JR.

NOTE

If a display of + 1.0000 cannot be attained with A1R89 after installing the proper jumper combination, a new jumper combination must be selected. If the + 1.0000 display is low, install the jumper combination from the line in Table 5-8 preceding the jumper combination installed. If the + 1.0000 display is high, install the jumper combination from the line in Table 5-8 succeeding the jumper combination installed.

5-34. Input Amplifier Adjustments.

5-35. Input Amplifier Gain Adjustment (R76). A DC Standard is required for this adjustment.

- a. Set the Multimeter function to DCV (==== V) and range to 20 m.
- b. Connect a short across the input terminals (V Ω and COM) and adjust the Multimeter display for 0.000 with R25 (rear panel ZERO ADJ).
- c. Remove the short from the input terminals and apply + 10 mV to the input terminals from the DC Standard.
- d. Adjust R76 (INPUT AMP GAIN ADJ) for a Multimeter display of $+ 10.000 \pm 3$ counts.

5-36. Input Amplifier Balance Adjustment (R50/R51 potentiometer). The input amplifier balance adjustment must be performed if A1CR17, A1U1 or A1R75 are replaced. A voltmeter is required for this adjustment.

- a. Set Multimeter function to DCV (==== V) and range to 2 V.

Table 5-9. Power Supply Jumpers.

READING		POWER SUPPLY JUMPER				
LO	HI	16	8	4	2	1
NOTE 1	.8961	0	0	0	0	0
	.8962	0	0	0	0	1
	.8985	0	0	0	1	0
	.9009	0	0	0	1	1
	.9033	0	0	1	0	0
	.9058	0	0	1	0	1
	.9083	0	0	1	1	0
	.9109	0	0	1	1	1
	.9135	0	1	0	0	0
	.9162	0	1	0	C	1
	.9190	0	1	0	1	0
	.9218	0	1	0	1	1
	.9246	0	1	1	0	0
	.9275	0	1	1	0	1
	.9305	0	1	1	1	0
	.9336	0	1	1	1	1
	.9367	1	0	0	0	0
	.9398	1	0	0	0	1
	.9431	1	0	0	1	0
	.9464	1	0	0	1	1
	.9498	1	0	1	0	0
	.9533	1	0	1	0	1
	.9569	1	0	1	1	0
	.9605	1	0	1	1	1
	.9642	1	1	0	0	0
	.9681	1	1	0	0	1
	.9720	1	1	0	1	0
	.9760	1	1	0	1	1
	.9801	1	1	1	C	0
	.9844	1	1	1	0	1
	.9887	1	1	1	1	0
	.9931	1	1	1	1	1
	NOTE 2	1	1	1	1	1

"0" = Remove Jumper

"1" = Leave Jumper In Place

NOTE 1. For Readings less than .8922, adjustment cannot be made. Check A1CR17 zener voltage for $6.95 \text{ V} \pm 0.25 \text{ V}$.

NOTE 2. Adjustment cannot be made for readings greater than 1.0000. Check A1CR17 zener voltage for $6.95 \text{ V} \pm 0.25 \text{ V}$.

b. Connect ground to the gate of A1Q16 at the junction of A1C7.

c. Connect the Digital Voltmeter to DCTP.

d. Adjust R50/R51 for a Digital Voltmeter reading at DCTP of less than 1 mV.

5-37. Ohms Converter Adjustments (R58 and R69).

5-38. A Digital Voltmeter a $1 \text{ k}\Omega \pm 0.01\%$ resistor and a $10 \text{ M}\Omega \pm 0.01\%$ resistor are required for this adjustment.

a. Set Multimeter function to OHMS (Ω) and range to 2 K.

b. Short the Multimeter input terminals (V Ω and COM).

c. Connect Digital Voltmeter to junction of A1R78 and A1Q25 gate.

d. Adjust A1R69 (20 M Ω ADJ) for a Digital Voltmeter reading of $< 0.5 \text{ mV}$.

e. Remove the input short and the Digital Voltmeter.

f. Put the $1 \text{ k}\Omega$ resistor across the input terminals and adjust A1R58 (2 k Ω ADJ) for Multimeter display of 1.0000 ± 1 count. If R58 does not have enough range to achieve this display, cut jumper B to introduce A1R57 and readjust A1R58 for the 1.0000 ± 1 count display.

g. Change Multimeter range to 20 M.

h. Remove the $1 \text{ k}\Omega$ resistor at the input terminals and apply a 10 M Ω resistor across the input terminals. Adjust A1R69 for a display of 10.000 ± 3 counts.

i. Remove the 10 M Ω resistor at the input and change range to 2 K.

j. Repeat Steps f, g, h, and i (2 k Ω ADJ and 20 M Ω ADJ) until both adjustment specifications of Steps f and h are met.

5-39. AC - DC Converter Adjustments.

5-40. AC Overall Gain Adjustment (R204, J11, J12, R206, R208). An AC Standard is required for this adjustment. Set the AC Standard for an output of 1 V ac at 200 Hz. Set the Multimeter FUNCTION to ACV ($\sim \text{V}$) and RANGE to 2 V. Connect the AC Standard output to the Multimeter V Ω and COM terminals.

5-41. Procedure.

a. Adjust R204 for a Multimeter display of 1.0000 V ac .

b. If R204 has insufficient adjustment range, clip open J11.

c. If there is still insufficient adjustment range, clip open J12.

d. If there is still insufficient adjustment range, clip out R206.

e. If there is still insufficient adjustment range, clip out R208.

5-42. AC Converter High Frequency Adjustment: (C45). An AC Standard is required for this adjustment.

a. Set Multimeter function to ACV ($\sim \text{V}$) and range to 2 V.

b. Apply a 0.1 V, 20 kHz signal with the AC Standard to the input terminals.

c. Adjust A1C45 (CONVERTER HIGH FREQ ADJ) for a Multimeter display of $.1000 \pm 1$ count.

d. Maintain the AC Standard for the following adjustment.

5-43. AC Converter 200 mV and 20 V High Frequency Adjustment (C42). An AC Standard is required for this adjustment.

- a. Set Multimeter function to ACV (\sim V) and range to 200 m.
- b. Apply a 0.1 V, 20 kHz signal with the AC Standard to the input terminals.
- c. Adjust A1C42 (200 mV and 20 V High Freq. Adj.) for a Multimeter display of 100.04 ± 1 count.
- d. If adjusting A1C42 does not bring the Multimeter display within limits, clip out A1C48* and adjust A1C42 for a display of 100.04 ± 1 count.
- e. Maintain the AC Standard for the following adjustment.

5-44. High Frequency Attenuator Adjustment (C22). An AC Standard is required for this adjustment.

- a. Set Multimeter function to ACV (\sim V) and range to 20 V.
- b. Apply a 10 V, 20 kHz signal with the AC Standard to the input terminals.
- c. Adjust A1C22 (High Freq. Atten. Adj.) for a Multimeter display of 10.016 ± 2 counts.
- d. Remove AC Standard from input terminals.

PERFORMANCE TEST CARD

Hewlett-Packard Model 3465B
 Multi-meter
 Serial No. _____

Tests Performed By _____
 Date _____

PARAGRAPH NUMBER	TEST	TEST LIMIT	TEST RESULT
5-6	DC Voltmeter Accuracy		
	<u>20 mV Range</u>		
	1 mV	.998 - 1.002 mV	_____
	5 mV	4.996 - 5.004 mV	_____
	10 mV	9.955 - 10.005 mV	_____
	<u>200 mV Range</u>		
	10 mV	9.99 - 10.01 mV	_____
	50 mV	49.98 - 50.02 mV	_____
	100 mV	99.97 - 100.03 mV	_____
	<u>2 V Range</u>		
	0.1 V	.9999 - 1.0001 V	_____
	0.5 V	4.998 - 5.002 V	_____
	1.0 V	9.997 - 10.003 V	_____
	<u>20 V Range</u>		
	1 V	9.99 - 10.01 V	_____
	5 V	49.98 - 50.02 V	_____
	10 V	99.97 - 100.03 V	_____
	<u>200 V Range</u>		
	10 V	9.99 - 10.01 V	_____
	50 V	49.98 - 50.02 V	_____
100 V	99.97 - 100.03 V	_____	
<u>1000 V Range</u>			
100 V	99.8 - 100.2 V	_____	
500 V	499.7 - 500.3 V	_____	
1000 V	999.6 - 1000.4 V	_____	
5-8	DC Ammeter Accuracy		
	<u>200 μA Range</u>		
	10 μA	9.98 - 10.02 μA	_____
	50 μA	49.95 - 50.05 μA	_____
	100 μA	99.92 - 100.08 μA	_____
	<u>2 mA Range</u>		
	0.1 mA	.9998 - 1.0002 mA	_____
	0.5 mA	4.995 - 5.005 mA	_____
	1.0 mA	9.992 - 10.008 mA	_____
	<u>20 mA Range</u>		
	1 mA	0.998 - 1.002 mA	_____
	5 mA	4.993 - 5.007 mA	_____
10 mA	9.988 - 10.012 mA	_____	

PERFORMANCE TEST CARD (cont'd)

PARAGRAPH NUMBER	TEST	TEST LIMIT	TEST RESULT
5-8 (cont'd)	<u>200 mA Range</u>		
	10 mA	09.93 - 10.07 mA	_____
	50 mA	49.69 - 50.31 mA	_____
	100 mA	99.39 - 100.61 mA	_____
	<u>2000 mA Range</u>		
	100 mA	099.3 - 100.7 mA	_____
	500 mA	496.9 - 503.1 mA	_____
	1000 mA	993.9 - 1006.1 mA	_____
	5-10	<u>Ohms Accuracy</u>	
<u>200 Ω Range</u>			
10 Ω		09.98 - 10.02 Ω	_____
50 Ω		49.97 - 50.03 Ω	_____
100 Ω		99.96 - 100.04 Ω	_____
<u>2 kΩ Range</u>			
0.1 kΩ		.0999 - .1001 kΩ	_____
0.5 kΩ		.4998 - .5002 kΩ	_____
1 kΩ		.9997 - 1.0003 kΩ	_____
<u>20 kΩ Range</u>			
1 kΩ		.999 - 1.001 kΩ	_____
5 kΩ		4.998 - 5.002 kΩ	_____
10 kΩ		9.997 - 10.003 kΩ	_____
<u>200 kΩ Range</u>			
10 kΩ		9.99 - 10.01 kΩ	_____
50 kΩ		49.98 - 50.02 kΩ	_____
100 kΩ		99.97 - 100.03 kΩ	_____
<u>2000 kΩ Range</u>			
100 kΩ		99.9 - 100.1 kΩ	_____
500 kΩ		499.8 - 500.2 kΩ	_____
1000 kΩ		999.7 - 1000.3 kΩ	_____
<u>20 MΩ Range</u>			
1 MΩ	0.998 - 1.002 MΩ	_____	
5 MΩ	4.994 - 5.006 MΩ	_____	
10 MΩ	9.989 - 10.011 MΩ	_____	

PARAGRAPH NUMBER	TEST	TEST LIMIT	TEST RESULT
5-12	AC Voltage Accuracy		
	200 mV Range		
	40 Hz to 10 kHz		
	10 mV	9.93 - 10.07 mV	_____
	50 mV	49.87 - 50.13 mV	_____
	100 mV	99.80 - 100.20 mV	_____
	10 kHz - 20 kHz		
	10 mV	9.80 - 10.20 mV	_____
	50 mV	49.60 - 50.40 mV	_____
	100 mV	99.35 - 100.65 mV	_____
	2 V Range		
	40 Hz - 10 kHz		
	0.1 V	.0993 - .1007 V	_____
	0.5 V	.4987 - .5013 V	_____
	1.0 V	.9980 - 1.0020 V	_____
	10 kHz - 20 kHz		
	0.1 V	.0980 - .1020 V	_____
	0.5 V	.4960 - .5040 V	_____
	1.0 V	.9935 - 1.0065 V	_____
	20 V Range		
	40 Hz - 10 kHz		
	1 V	.993 - 1.007 V	_____
	5 V	4.987 - 5.013 V	_____
	10 V	9.980 - 10.020 V	_____
	10 kHz - 20 kHz		
	1 V	.980 - 1.020 V	_____
	5 V	4.960 - 5.040 V	_____
	10 V	9.935 - 10.065 V	_____
	200 V Range		
	40 Hz - 10 kHz		
10 V	9.93 - 10.07 V	_____	
50 V	49.87 - 50.13 V	_____	
100 V	99.80 - 100.20 V	_____	
10 kHz - 20 kHz			
10 V	9.80 - 10.20 V	_____	
50 V	49.60 - 50.40 V	_____	
100 V	99.35 - 100.65 V	_____	
500 V Range			
40 Hz - 1 kHz			
100 V	99.3 - 100.7 V	_____	
500 V	498.7 - 501.3 V	_____	
1 kHz - 2 kHz			
100 V	99.0 - 101.0 V	_____	
500 V	497.0 - 503.0 V	_____	

PERFORMANCE TEST CARD (cont'd)

PARAGRAPH NUMBER	TEST	TEST LIMIT	TEST RESULT
5-14	AC Ammeter Accuracy		
	200 μ A Range		
	10 μ A		
	100 Hz	9.91 – 10.09 μ A	_____
	199 μ A		
	100 Hz	198.25 – 199.85 mA	_____
	2 mA Range		
	0.1 mA		
	1 kHz	.0991 – .1009 mA	_____
	1.99 mA		
	1 kHz	1.9825 – 1.9985 mA	_____
	20 mA Range		
	1 mA		
	1 kHz	.992 – 1.008 mA	_____
	19.9 mA		
	1 kHz	19.825 – 19.985 mA	_____
	200 mA Range		
	10 mA	9.87 – 10.13 mA	_____
50 mA	49.65 – 50.45 mA	_____	
100 mA	99.15 – 100.85 mA	_____	
2000 mA Range			
100 mA	98.7 – 101.3 mA	_____	
500 mA	495.5 – 504.5 mA	_____	
1000 mA	991.5 – 1008.5 mA	_____	

PERFORMANCE TEST CARD (cont'd)

PARAGRAPH NUMBER	TEST	TEST LIMIT	TEST RESULT
5-15	Normal Mode Rejection	< .007 V (60 dB)	_____
5-17	Common Mode Rejection	< 10 μ V (12) dB)	_____
5-20	DC Input Resistance 20 V – 1000 V Range 2 mV – 2 V Range	4.975 – 5.025 (10 M) > .9990 (10^{10} ohms)	_____ _____
5-22	Input Impedance Resistive component Shunt capacitance	.4975 – .5025 .7071 – 1.0000	_____ _____

SECTION VI REPLACEABLE PARTS

6-1. INTRODUCTION.

6-2. This section contains information for ordering replacement parts. Table 6-3 lists parts in alphanumeric order of their reference designators and indicates the description, -hp- Part Number of each part, together with any applicable notes, and provides the following:

- a. Total quantity used in the instrument (Qty column). The total quantity of a part is given the first time the part number appears.
- b. Description of the part. (See list of abbreviations in Table 6-1.)
- c. Typical manufacturer of the part is a five-digit code. (See Table 6-2 for list of manufacturers.)
- d. Manufacturer's part number.

6-3. Miscellaneous parts are listed in Table 6-3 following their respective assemblies. General miscellaneous parts are listed at the conclusion of Table 6-3.

6-4. ORDERING INFORMATION.

6-5. To obtain replacement parts, address order or inquiry to your local Hewlett-Packard Field Office. (See Appendix A for list of office locations.) Identify parts by their Hewlett-Packard part numbers. Include instrument model and serial numbers.

6-6. NON-LISTED PARTS.

6-7. To obtain a part that is not listed, include:

- a. Instrument model number.
- b. Instrument serial number.
- c. Description of the part.
- d. Function and location of the part.

6-8. PARTS CHANGES.

6-9. Components which have been changed are so marked by one of three symbols; i.e., Δ, Δ with a letter subscript, e.g., Δ_a, or Δ with a number subscript, e.g., Δ₁₀. A Δ with no subscript indicates the component listed is the preferred replacement for an earlier component. A Δ with a letter subscript indicates a change which is explained in a note at the bottom of the page. A Δ with a number subscript indicates the related change is discussed in backdating (Section VIII). The number of the subscript indicates the number of the change in backdating which should be referred to.

6-10. PROPRIETARY PARTS.

6-11. Items marked by a dagger (†) in the reference designator column are available only for repair and service of Hewlett-Packard instruments.

Table 6-1. List of Abbreviations.

ABBREVIATIONS											
Ag	silver	Hz	hertz (cycles per second)	h	hours	h	hertz	H	high relative zero (zero temperature coefficient)	h	hose
Al	aluminum	IO	inside diameter	hp	horsepower	SPDT	single pole double throw	SPST	single pole single throw	TC	temperature coefficient
Au	gold	imp	impregnated	me	meter	TC	temperature coefficient	TC	temperature coefficient	TC	temperature coefficient
C	capacitor	incd	incandescent	mm	millimeter	TC	temperature coefficient	TC	temperature coefficient	TC	temperature coefficient
car	ceramic	ins	insulation	mm	millimeter	TC	temperature coefficient	TC	temperature coefficient	TC	temperature coefficient
con	coefficient	iso	isothermal = 10 ⁻³ ohms	mm	millimeter	TC	temperature coefficient	TC	temperature coefficient	TC	temperature coefficient
com	common	kHz	kahertz = 10 ³ hertz	mm	millimeter	TC	temperature coefficient	TC	temperature coefficient	TC	temperature coefficient
comp	composition	L	inch long	mm	millimeter	TC	temperature coefficient	TC	temperature coefficient	TC	temperature coefficient
conn	connection	ln	inch long	mm	millimeter	TC	temperature coefficient	TC	temperature coefficient	TC	temperature coefficient
dep	deposited	lug	inch long	mm	millimeter	TC	temperature coefficient	TC	temperature coefficient	TC	temperature coefficient
DPDT	double pole double throw	mA	milliamperes = 10 ⁻³ amperes	mm	millimeter	TC	temperature coefficient	TC	temperature coefficient	TC	temperature coefficient
DPST	double pole single throw	MHz	megahertz = 10 ⁶ hertz	mm	millimeter	TC	temperature coefficient	TC	temperature coefficient	TC	temperature coefficient
elect	electrolytic	MΩ	megohms = 10 ⁶ ohms	mm	millimeter	TC	temperature coefficient	TC	temperature coefficient	TC	temperature coefficient
encap	encapsulated	met film	metal film	mm	millimeter	TC	temperature coefficient	TC	temperature coefficient	TC	temperature coefficient
F	ferrous	my	mylar	mm	millimeter	TC	temperature coefficient	TC	temperature coefficient	TC	temperature coefficient
FET	field effect transistor	mg	milligram	mm	millimeter	TC	temperature coefficient	TC	temperature coefficient	TC	temperature coefficient
hd	hard	mV	millivolts = 10 ⁻³ volts	mm	millimeter	TC	temperature coefficient	TC	temperature coefficient	TC	temperature coefficient
GaAs	gallium arsenide	μF	microfarads	mm	millimeter	TC	temperature coefficient	TC	temperature coefficient	TC	temperature coefficient
GHz	gigahertz = 10 ⁹ hertz	μV	microvolts = 10 ⁻⁶ volts	mm	millimeter	TC	temperature coefficient	TC	temperature coefficient	TC	temperature coefficient
h	hour	μV	microvolts = 10 ⁻⁶ volts	mm	millimeter	TC	temperature coefficient	TC	temperature coefficient	TC	temperature coefficient
hp	horsepower	NA	nanosecond = 10 ⁻⁹ seconds	mm	millimeter	TC	temperature coefficient	TC	temperature coefficient	TC	temperature coefficient
hg	mercury	nc	normally closed	mm	millimeter	TC	temperature coefficient	TC	temperature coefficient	TC	temperature coefficient
		no	normally open	mm	millimeter	TC	temperature coefficient	TC	temperature coefficient	TC	temperature coefficient

DESIGNATORS									
A	assembly	FL	flex	Q	quartz	TS	transistor	TS	terminal strip
B	battery	HR	heater	QCR	quartz crystal resonator	U	vacuum tube, neon bulb, photocell, etc.	U	microcircuit
BT	battery	IC	integrated circuit	RPI	resistor package	V	vacuum tube, neon bulb, photocell, etc.	V	vacuum tube, neon bulb, photocell, etc.
C	capacitor	J	jack	RT	resistor	W	wire	W	wire
CR	diode or thyristor	L	lug	RZ	resistor	K	knob	K	knob
DL	dry line	M	meter	T	transformer	KCS	knob	KCS	knob
DS	dry line	L	lug	TS	terminal board	RF	radio frequency	RF	radio frequency
E	electronic part	MP	mechanical part	TC	thermocouple	V	vacuum tube, neon bulb, photocell, etc.	V	vacuum tube, neon bulb, photocell, etc.
F	fuse	P	plug	TP	test point	Z	zener diode	Z	zener diode

Table 5-2. Code List of Manufacturers.

MFR NO.	MANUFACTURER'S CODE LIST	ADDRESS
00000	U.S.A. COMMON	ANY SUPPLIER OF USA
00160	OHARA METAL PRODUCTS	SAN FRANCISCO CAL 94107
01121	ALLEY BRADLEY CO.	MILWAUKEE WI 53212
01295	TEXAS INSTRUMENT INC. SEMICONDUCTOR CMPNT DIV.	DALLAS TX 75231
01666	RCL ELECTRONICS INC.	MANCHESTER NH 03102
02736	RCA CORP. SOLID STATE DIV.	SOMMERSVILLE NJ 08876
03888	PYROFILM CORP.	WHIPPANY NJ 07981
04712	MOTOROLA SEMICONDUCTOR PRODUCTS	PHOENIX AZ 85008
12954	DICKSON ELECTRONICS CORP.	SCOTTSDALE AZ 85252
14140	EDISON ELEK DIV MCGRAW-EDISON	MANCHESTER NH 03130
16299	CORNING GLASS WORKS ELEC CMPNT DIV.	RALEIGH NC 27604
17866	SILICONIX INC.	SANTA CLARA CA 95050
19701	MEPCO/ELECTRA CORP.	MINERAL WELLS TX 76067
24546	CORNING GLASS WORKS (BRADFORD)	BRADFORD PA 16701
27014	NATIONAL SEMICONDUCTOR CORP.	SANTA CLARA CA 95051
28480	HEWLETT-PACKARD CO. CORPORATE HQ	PALO ALTO CA 94304
32997	BOURNS INC TRIMPOT PROD DIV.	RIVERSIDE CA 92701
56289	SPRAGUE ELECTRIC CO.	NORTH ADAMS MA 01247
71400	BUSSMAN MFG DIV OF MCGRAW-EDISON CO.	ST LOUIS MO 63017
72136	ELECTRO MOTIVE MFG CO., INC.	WILLIMANTIC CT 06226
73138	BECKMAN INSTRUMENTS INC HELIPOT DIV.	FULLERTON CA 92634
74970	JOHNSON E. F. CO	WASECA MN 56093
84411	TRW CAPACITOR DIV	OGALLALA NE 69163
91606	AUGAT INC	ATTLEBORO MA 02703
95121	QUALITY COMPONENTS INC	ST MARYS PA 15857
98291	EALECTRO CORP.	MAMARONECK NY 10544

Table S-3. Replaceable Parts

Reference Designation	HP Part Number	Qty	Description	Mfr Code	Mfr Part Number
A1	03465-66631	1	PC ASSEMBLY, MAIN	28480	03465-66631
A1 C1	0140-0207	3	CAPACITOR-FXD 33PF +-5% 300VDC MICA	72126	DM15F471J0300WV1CR
A1 C7	0180-0374	1	CAPACITOR-FXD 10UF +-10% 25VDC TA-SOLID	56289	150D106X9020H2
A1 C3	0150-0071	7	CAPACITOR-FXD 400PF +-5% 1000VDC CER	28480	0150-0071
A1 C4	0160-0850	1	CAPACITOR-FXD 1UF +-10% 50VDC POLYE	28480	0160-0850
A1 C5	0150-1743	1	CAPACITOR-FXD 1UF +-10% 35VDC TA-SOLID	56289	150C104X9030A2
A1 C6	0160-0155	1	CAPACITOR-FXD 0.6UF +-10% 200VDC POLYE	56289	292F56302
A1 C7	0160-2207	1	CAPACITOR-FXD 300PF +-5% 300VDC MICA	28480	0160-2207
A1 C8, C9	0150-0071	1	CAPACITOR-FXD 400PF +-5% 1000VDC CER	28480	0150-0071
A1 C10	0170-0056	1	CAPACITOR-FXD 1UF +-20% 200VDC POLYE	56289	292P10407
A1 C12	0150-2204	1	CAPACITOR-FXD 100PF +-5% 300VDC MICA	28480	0160-2204
A1 C13	0160-2046	2	CAPACITOR-FXD 2PF +-5% 500VDC MICA	28480	0160-2046
A1 C16	0150-0161	1	CAPACITOR-FXD 01UF +-5% 200 VDC POLYE	28480	0160-0161
A1 C18	0160-0210	1	CAPACITOR-FXD 33UF +-20% 15VDC TA	56289	150D326X0016A2
A1 C19	0160-4147	1	CAPACITOR-FXD 0.44 UF 0.10%	28480	0150-4347
A1 C20	0160-2206	2	CAPACITOR-FXD 120PF +-5% 300VDC MICA	28480	0160-2206
A1 C21	0160-0362	1	CAPACITOR-FXD 510PF +-5% 300VDC MICA	28480	0160-0362
A1 C22	0121-0128	1	CAPACITOR-VAR TRMR, AIR, 1.4 9 2PF	74970	120-0503-005
A1 C23	0150-0073	1	CAPACITOR-FXD 100PF +-10% 1000VDC	56256	C078D102E101K527 CDH
A1 C24	0180-0224	4	CAPACITOR-FXD 22UF +-10% 15VDC TA-SOLID	56289	150D226X9015B2
A1 C25	0140-0317	1	CAPACITOR-FXD 330PF +-5% 500VDC MICA	72126	DM15F331J0500WV1CR
A1 C26	0180-0278	1	CAPACITOR-FXD 22UF +-10% 15VDC TA-SOLID	56289	150D226X9015B2
A1 C27	0150-0852	1	CAPACITOR-FXD 0.6UF +-20% 400VDC CER	28480	0150-0852
A1 C28	0160-2055	1	CAPACITOR-FXD 0.1UF +-80-20% 25VDC CER	28480	0160-2055
A1 C29	0160-0157	1	CAPACITOR-FXD 4700PF +-10% 200VDC POLYE	56289	292P47292
A1 C30	0160-2055	1	CAPACITOR-FXD 01UF +-80-20% 100VDC	28480	0160-2055
A1 C31	0160-0207	1	CAPACITOR-FXD 01UF +-5% 200 VDC	28480	0160-0207
A1 C32	0180-1266	5	CAPACITOR-FXD 33UF +-10% 10VDC TA-SOLID	28480	0180-0666
A1 C33	0160-0153	1	CAPACITOR-FXD 1000PF +-10% 200VDC POLYE	56289	292P10292
A1 C34, C35	0180-0666	1	CAPACITOR-FXD 33UF +-10% 10VDC TA-SOLID	28480	0180-0666
A1 C36-C38	0160-0168	3	CAPACITOR-FXD 1UF +-10% 200VDC POLYE	56289	292P10407
A1 C39*	0160-0209	1	CAPACITOR 5PF +-10% 500VDC MICA	04527	DM15C050K0500WV1CR
A1 C41	0160-0291	2	CAPACITOR-FXD 1UF +-10% 35VDC TA-SOLID	56289	150D106X9015A2
A1 C42	0121-0424	1	CAPACITOR-VAR, TRMR, MICA, 50 380PF	72126	152517 7
A1 C43	0160-2206	1	CAPACITOR-FXD 120PF +-5% 300VDC MICA	28480	0160-2206
A1 C44	0180-0201	1	CAPACITOR-FXD 11F +-10% 35VDC TA-SOLID	56289	150D106X9035A2
A1 C45	0121-0147	1	CAPACITOR-VAR, TRMR, AIR, 7 19 3PF	74970	189-507 5
A1 C46, C47	0150-0029	2	LAPACITOR-FXD 10F +-10% 500VDC TI	95121	TYPE OC
A1 C48	0140-0207	1	CAPACITOR-FXD 330PF +-5% 500VDC MICA	72126	DM15F331J0500WV1CR
A1 C49	0150-2115	1	CAPACITOR-FXD 13UF +-10% 50VDC POLYE	56289	148P345
A1 C51, C52	0160-0229	1	CAPACITOR-FXD 22UF +-10% 15VDC TA-SOLID	56289	150D226X9015B2
A1 C53, C54	0180-0666	1	CAPACITOR-FXD 33UF +-10% 10VDC TA-SOLID	28480	0180-0666
A1 C55*			SEE PADDING LIST UNDER A1 ASSY MISC PARTS		
A1 C58	0150-0071	1	CAPACITOR-FXD 400PF +-5% 1000VDC CER	28480	0150-0071
A1 C100	0150-0121	1	CAPACITOR-FXD 1UF +-80-20% 50VDC	28480	0150-0121
A1 C101, C104	0160-2055	1	CAPACITOR-FXD 01UF +-80-20% 100VDC	28480	0160-2055
A1 C105	0160-2201	1	CAPACITOR-FXD 51PF +-5% 300VDC	28480	0160-2201
A1 C110, C112	0150-0071	1	CAPACITOR-FXD 400PF 1000V	28480	0150-0071
A1 C114	0180-0391	1	CAPACITOR-FXD 30UF +-10% 10VDC	56289	150D306X9010B2
A1 C115	0180-0335	1	CAPACITOR-FXD 501F 16V	56289	300506G016CB2
A1 CR1, CR2	1901-0040	11	DIODE SWITCHING	28480	1901-0040
A1 CR3, CR4	1901-0090	4	DIODE SWITCHING	28480	1901-0052
A1 CR5, CR6	1901-0540	1	DIODE SWITCHING	28480	1901-0040
A1 CR7	1906-0090	1	DIODE-FWBRDG 200V 2A	02037	ADA202
A1 CR8, CR9	1901-0581	2	DIODE-GEN PRP 30V 25MA	28480	1901-0586
A1 CR10, CR11	1902-1042	2	DIODE-ZNR 3.02V 5% DO-7FD-4W TC-049%	04713	SZ 10939 65
A1 CR15, CR16	1801-03 6	5	DIODE-GEN PRP 35V 50MA	28480	1901-0376
A1 CR17	1902-12 8	1	DIODE-ZNR	28480	1902-1318
A1 CR18	1910-0434	1	DIODE-SWITCHING 8NS 30V 80MA	28480	1910-0034
A1 CR19	1902-3 36	1	DIODE-ZNR 8.06V 5% DO-7PD-4W TC-052%	04713	SZ 10939 155
A1 CR20	1902-3 182	3	DIODE-ZNR 12.1V 5% DO-7PD-4W TC-064%	04713	SZ 10939 206
A1 CR21	1902-3 21	1	DIODE-ZNR 6.9V 4% TO-18 TC-0015%	28480	1902-1331
A1 CR24, CR25	1901-0340	1	DIODE-SWITCHING 2NS 30V 50MA	28480	1901-0040
A1 CR26	1901-3376	1	DIODE-GEN PRP 35V 50MA	28480	1901-0376
A1 CR27			NOT ASSIGNED		
A1 CR28	1901-0029	1	DIODE-PWR RECT 600V 750MA	28480	1901-0029
A1 CR29	1901-0040	1	DIODE-SWITCHING 2NS 30V 50MA	28480	1901-0040
A1 CR30	1910-0034	1	DIODE-SWITCHING 8NS 30V 80MA	28480	1910-0034
A1 CR31	1910-0034	1	DIODE-SWITCHING 8NS 30V 80MA	28480	1901-0060
A1 CR33, CR34	1901-0050	1	DIODE SWITCHING	28480	1901-0040
A1 CR35, CR37	1901-0040	1	DIODE-SWITCHING 2NS 30V 50MA	28480	1901-0037
A1 CR38, CR39	1910-0376	1	DIODE-GEN PRP 35V 50MA	28480	1901-0040
A1 CR50	1901-0040	1	DIODE-SWITCHING 2NS 30V 50MA	28480	2110 0099
A1 F100	2 10-0029	1	FUSE-1A 125V	28480	1251-4109
A1 J1	1251-4109	1	CONNECTOR STRIP-25-PIN	28480	56-500-65-448
A1 L1, L3, L4	1170-0894	4	CORE-SHIELDING BEAD	02114	2N4117
A1 Q1	855-0208	3	TRANSISTOR J-FET 2N4117 N-CHAN D-MODE	28480	1855-0308
A1 Q2	1855-0308	2	TRANSISTOR J-FET DUAL N-CHAN D-MODE S1	28480	1854-0071
A1 Q3	1854-0071	11	TRANSISTOR NPN S1	28480	1853-0086
A1 Q4, Q5	1853-0086	8	TRANSISTOR PNP S1	28480	

Table 6-3. Replaceable Parts

Reference Designation	HP Part Number	Qty	Description	Mfr Code	Mfr Part Number
A1 Q6	1854-0071		TRANSISTOR NPN SI	28480	1854-0071
A1 Q7	1853-0066		TRANSISTOR PNP SI	28480	1853-0066
A1 Q8 Q9	1854-0071		TRANSISTOR NPN SI	28480	1854-0071
A1 Q10, Q11	1853-0066		TRANSISTOR PNP SI	28480	1853-0066
A1 Q12	1854-0071		TRANSISTOR NPN SI	28480	1854-0071
A1 Q13	1853-0066		TRANSISTOR PNP SI	28480	1853-0066
A1 Q16	1856-0272	1	TRANSISTOR J-FET DUAL D-MODE SI	28480	1856-0272
A1 Q17	1854-0071		TRANSISTOR NPN SI	28480	1854-0071
A1 Q18	1853-0066		TRANSISTOR PNP SI	28480	1853-0066
A1 Q19, Q20	1856-0208		TRANSISTOR J-FET 2N4117 N-CHAN D-MODE	1856	2N4117
A1 Q23, Q24	1856-0093	2	TRANSISTOR J-FET N-CHAN D-MODE TO-18 SI	28480	1856-0093
A1 Q25	1856-0308		TRANSISTOR J-FET DUAL N-CHAN D-MODE SI	28480	1856-0308
A1 Q26	1854-0071		TRANSISTOR NPN SI	28480	1854-0071
A1 Q27	1853-0020	6	TRANSISTOR PNP SI	28480	1853-0020
A1 Q30	1854-0079	1	TRANSISTOR NPN 2N3439 SI TO 5 PD-1W	02735	2N3439
A1 Q31	1854-0071		TRANSISTOR NPN SI	28480	1854-0071
A1 Q32	1853-0066		TRANSISTOR PNP SI	28480	1853-0066
A1 Q33	1853-0318	1	TRANSISTOR PNP SI	04713	MP56562
A1 Q34, Q35	1854-0071		TRANSISTOR NPN SI	28480	1854-0071
A1 Q36, Q37	1853-0020		TRANSISTOR PNP SI	28480	1853-0020
A1 Q38	1854-0071		TRANSISTOR NPN SI	28480	1854-0071
A1 Q50, Q51	1853-0020	5	TRANSISTOR PNP SI	28480	1853-0020
A1 R1	0608-2572	5	RESISTOR 60K 1% .125W	16299	C4-1.0 TO 6042 F
A1 R2	0683-3335	3	RESISTOR 33K 5% .25W	01121	CB3335
A1 R3	0757-0442	1	RESISTOR 10K 1% .125W	24546	C4-1.8 TO 1002 F
A1 R4	0683-2225	2	RESISTOR 22K 5% .25W	01121	CB2225
A1 R5	0683-6635	2	RESISTOR 66K 5% .25W	01121	CB6635
A1 R6	0757-0344	1	RESISTOR 1M 1% .25W	24546	C5-1.4 TO 1004 F
A1 R7	0757-0288		RESISTOR 900K 1% .125W	19701	MF4C1.8 TO 9001 F
A1 R8	0683-1045	7	RESISTOR 100K 5% .25W	01121	CB1045
A1 R9	0683-3025	1	RESISTOR FXD JK OHM 5% 1W	28480	0683-3025
A1 R11	0683-2235	1	RESISTOR 22K 5% .25W	01121	CB2235
A1 R12	0683-4725	3	RESISTOR 47K 5% .25W	01121	CB4725
A1 R13	0757-0449	2	RESISTOR 20K 1% .125W	24546	C4-1.8 TO 2002 F
A1 R14	0683-4121		RESISTOR 499 1% .125W	16299	C4-1.8 TO 499H F
A1 R15	0683-4735	5	RESISTOR 47K 5% .25W	01121	CB4735
A1 R16	0683-4725		RESISTOR 47K 5% .25W	01121	CB4725
A1 R17	0683-3025	1	RESISTOR JK 5% .25W	01121	CB3025
A1 R18, R19	0608-1572		RESISTOR FXD JK 1% .125W	16299	C4-1.8 TO 6042 F
A1 R20	0757-0472	3	RESISTOR 200K 1% .125W	21546	C4-1.8 TO 2003 F
A1 R21	0683-3215	1	RESISTOR 400K 1% .125W	03888	PME555
A1 R22	0757-0472		RESISTOR 200K 1% .125W	24546	C4-1.8 TO 2003 F
A1 R23	0683-4496	1	RESISTOR 453K 1% .125W	24546	C4-1.8 TO 4532 F
A1 R24	0683-6645	3	RESISTOR 660K 5% .25W	01121	CB6645
A1 R25	2100-3366	1	RESISTOR-VAR TRMR 100K 20% C SIDE ADJ	73138	72PR1M
A1 R26	0683-1056	5	RESISTOR 1M 5% .25W FC TC--600/900	01121	CB1056
A1 R27	0683-3228	4	RESISTOR 49.9K 1% .125W F TC++-100	28480	0683-3228
A1 R28, R29	0757-0465	2	RESISTOR 100K 1% .125W	24546	C4-1.8 TO 1003 F
A1 R30	0811-3428	1	RESISTOR 1 5% 4W PW	28480	0811-3428
A1 R31	0811-3427	1	RESISTOR 0 5% 4W PW	25480	0811-3427
A1 R32	0811-3393	1	RESISTOR 0 1% 062W PWW	14140	1274
A1 R33	0811-3390	1	RESISTOR 00 5% 031W PWW	14140	1274
A1 R34	0811-3392	1	RESISTOR 000 0% 031W PWW	14140	1274
A1 R35-R37	0683-7535	3	RESISTOR 75K 5% .25W F TC--400/800	01607	CB7535
A1 R38	0683-1036	8	RESISTOR 10K 5% .25W	01121	CB1036
A1 R39	0683-7332	1	RESISTOR 1M 1% .125W	19701	MF5C1.8 TO 1004 F
A1 R40	0757-0449		RESISTOR FXD 20K 1%	24546	C4-1.8 TO 2002 F
A1 R41	0683-1045		RESISTOR 100K 5% .25W	01121	CB1045
A1 R42	0683-4539	1	RESISTOR 402K 1% .125W	03988	PME555
A1 R43	0683-4541	2	RESISTOR 442K 1% .125W	03888	PME555
A1 R44	0683-2745	2	RESISTOR 270K 5% .25W	01121	CB2745
A1 R45	0683-1045		RESISTOR 100K 5% .25W	01121	CB1045
A1 R46, R47	0683-1036		RESISTOR 10K 5% .25W	01121	CB1036
A1 R48	0683-1056		RESISTOR 1M 5% .25W	01121	CB1056
A1 R49	0683-2435	1	RESISTOR 24K 5% .25W	01121	CB2435
A1 R50	2100-0554	3	RESISTOR-VAR TRMR 500 OHM 10% C TOP ADJ	73138	72PR500
A1 R52	0683-6635		RESISTOR 66K 5% .25W	01121	CB6635
A1 R53	0683-1245	3	RESISTOR 120K 5% .25W	01121	CB1245
A1 R54	0683-1035		RESISTOR 10K 5% .25W	01121	CB1035
A1 R56	0811-2764	1	RESISTOR 995K 1% .125W	14140	1250 1.8 D 9952 B
A1 R57	0608-3446	1	RESISTOR 383 1% .125W	16299	C4-1.8 TO 383R F
A1 R58	2100-0554		RESISTOR-VAR TRMR 500 OHM 10% C TOP ADJ	73138	72PR500
A1 R59	0683-4541		RESISTOR 442K 1% .125W	03888	PME555

Table 6-3. Replaceable Parts

Reference Designation	HP Part Number	Qty	Description	Mfr Code	Mfr Part Number
A1 R60	0683-1045	1	RESISTOR 100K 5% 25W	01121	CB1045
A1 R61	0683-2406	1	RESISTOR 24 5% 25W	01121	CB2406
A1 R62	0683-1065	1	RESISTOR 10M 5% 25W	01121	CB1065
A1 R63	0683-1215	9	RESISTOR 120 5% 25W	01121	CB1215
A1 R64	0683-1041	2	RESISTOR 100K 10% 2W	01121	HB1041
A1 R65	0683-1545	1	RESISTOR 150K 5% 25W	01121	CB1545
A1 R66	0683-9135	1	RESISTOR 91K 5% 25W	01121	CB9135
A1 R67	0683-6845	1	RESISTOR 680K 5% 25W	01121	CB6845
A1 R68	0757-0462	1	RESISTOR 75K 1% 125W	24546	C4-1.8-TO-1502-F
A1 R69	2100-0654	1	RESISTOR-VAR TRMR 500 OHM 10% C TOP ADJ	73138	72PR500
A1 R70*			SEE PADDING LIST UNDER A1 ASSY MISC PARTS		
A1 R71	0608-8345	1	RESISTOR 634K 1% 125W	19701	MF5C1.8-TO-6343-F
A1 R72	0757-0472	1	RESISTOR 700K 1% 125W	24546	C4-1.8-TO-2003-F
A1 R73	0608-4470	1	RESISTOR 608K 1% 125W	24546	C4-1.8-TO-6081-F
A1 R74	0608-3279	1	RESISTOR 409K 1% 125W	16299	C3-1.8-TO-4091-F
A1 R75	1810-0253	1	FINE LINE ASSEMBLY	28480	1810-0253
A1 R76	2100-0658	1	RESISTOR-VAR TRMR 20 KOHM 10% C TOP ADJ	73138	72PR20K
A1 R78	0683-4735	1	RESISTOR 47K 5% 25W	01121	CB4735
A1 R79	0683-2006	1	RESISTOR 20 5% 25W	01121	CB2006
A1 R80	0683-2225	1	RESISTOR 22K 5% 25W	01121	CB2225
A1 R81	0683-3015	2	RESISTOR 300 5% 25W	01121	CB3015
A1 R82	0683-1041	1	RESISTOR 100K 10% 2W	01121	HB1041
A1 R83	0683-1025	1	RESISTOR 1K 5% 25W	01121	CB1025
A1 R84, R85	0608-3672	1	RESISTOR 604K 1% 125W	16299	C4-1.8-TO-6042-F
A1 R86	0683-4725	1	RESISTOR 47K 5% 25W	01121	CB4725
A1 R87	0683-1035	1	RESISTOR 10K 5% 25W	01121	CB1035
A1 R88	0683-6125	3	RESISTOR 51K 5% 25W	01121	CB5125
A1 R89	2100-3212	1	RESISTOR-VAR TRMR 700 OHM 10% C SIDE ADJ	32797	3386P-Y46-201
A1 R90	0683-1015	2	RESISTOR 100 OHM 5% 25W	01121	CB1015
A1 R91	0683-4705	1	RESISTOR 47 5% 25W	01121	CB4705
A1 R92	0683-1545	1	RESISTOR 150K 5% 25W	01121	CB1545
A1 R93	0683-2745	1	RESISTOR 270K 5% 25W	01121	CB2745
A1 R94	0757-0410	1	RESISTOR 301 1% 125W	24546	C4-1.8-TO-301R-F
A1 R95	0683-1045	1	RESISTOR 100K 5% 25W	01121	CB1045
A1 R96	0683-3015	1	RESISTOR 300 5% 25W	01121	CB3015
A1 R1	0683-1505	1	RESISTOR 15 5% 25W	01121	CB1505
A1 R1, 1-R102	0608-3456	3	RESISTOR 287K 1% 125W	16299	C4-1.8-TO-2873-F
A1 R103	0683-1245	1	RESISTOR 120K 5% 25W	01121	CB1245
A1 R104	0683-2245	1	RESISTOR 220K 5% 25W	01121	CB2245
A1 R105	0608-8203	1	RESISTOR 120K 1% 125W	19701	MF4C1.8-T10-1203-F
A1 R109	0692-4735	1	RESISTOR 47K 5% 2W	01121	HB4735
A1 R110	0683-2425	1	RESISTOR 24K 5% 25W	01121	CB2425
A1 R112	0683-6125	1	RESISTOR 51K 5% 25W	01121	CB5125
A1 R113	0683-4755	1	RESISTOR 47K 5% 25W	01121	CB4755
A1 R114	0608-3149	1	RESISTOR 255K 1% 125W	16299	C4-1.8-TO-2553-F
A1 R115	0681-6845	1	RESISTOR 680K 5% 25W	01121	CB6845
A1 R116	0683-1545	1	RESISTOR 150K 5% 25W	01121	CB1545
A1 R117	0757-0478	1	RESISTOR 365K 1% 125W	19701	MF4C1.8-TO-3653-F
A1 R118	0608-6871	2	RESISTOR 10K 5% 125W	03868	PME555
A1 R119	0683-1055	1	RESISTOR 1M 5% 25W	01121	CB1055
A1 R120	0683-4735	1	RESISTOR 47K 5% 25W	01121	CB4735
A1 R123	0683-1035	1	RESISTOR 10K 5% 25W	01121	CB1035
A1 R124	0683-1055	1	RESISTOR 1M 5% 25W	01121	CB1055
A1 R125	0698-6385	2	RESISTOR 220K 1% 125W	03868	PME555
A1 R126	0608-6871	1	RESISTOR 10K 5% 125W	03868	PME555
A1 R127	0608-6385	1	RESISTOR 220K 1% 125W F TC-0+-25	28480	0608-6385
A1 R131	0608-6362	1	RESISTOR 1K 1% 125W	24546	NE55
A1 R132	0698-8613	1	RESISTOR FXD 897K OHM 0.1% 125W F	28480	0698-8613
A1 R133	2100-3383	1	RESISTOR-VAR TRMR 50 OHM 10% C TOP ADJ	73138	72PR50
A1 R135	0683-1245	1	RESISTOR 120K 5% 25W	01121	CB1245
A1 R139	0608-4504	1	RESISTOR 698K 1% 25W	24546	C4-1.8-TO-6982-F
A1 R141	0757-0978	1	RESISTOR 953K 1% 125W	24546	C4-1.8-TO-9532-F
A1 R142, R143	0683-3335	1	RESISTOR 33K 5% 25W	01121	CB3335
A1 R144	0683-1035	1	RESISTOR 10K 5% 25W	01121	CB1035
A1 R145, R146	0683-4735	1	RESISTOR 47K 5% 25W	01121	CB4735
A1 R147	0683-1035	1	RESISTOR 10K 5% 25W	01121	CB1035
A1 R148	0683-1055	1	RESISTOR 1M 5% 25W	01121	CB1055
A1 R149	0683-1045	1	RESISTOR 100K 5% 25W	01121	CB1045
A1 R160	0757-0081	4	RESISTOR 475K 1% 25W	28480	0757-0081
A1 R200, R201	0683-2045	2	RESISTOR 204K 5% 25W	01121	CB2045
A1 R202	0683-1045	7	RESISTOR 100K 5% 25W	01121	CB1045
A1 R203*	0757-0407	1	RESISTOR 200 1% 125W	24546	C4-1.8-TO-201-F
A1 R204	2100-0667	1	RESISTOR 100 1% 125W	03292	C4-1.8-TO-101-F
A1 R205	0757-0283	1	RESISTOR TRMR 2K 10% C TOP ADJ	32997	3386P-Y46-202
A1 R206-209	0608-3152	1	RESISTOR 2K 1% 125W	24546	C4-TO-2001-F
			RESISTOR 2480 OHM 1% 125W	16922	C4-TO-J481-F

Table 6-3. Replaceable Parts

Reference Designation	HP Part Number	Qty	Description	Mfr Code	Mfr Part Number
A1R210	0683-5126		RESISTOR 5.1K 5% .25W	01607	CB5125
A1R211	0683-2015		RESISTOR 200 5% .25W	01607	CB2015
A1R212	0683-1015		RESISTOR 100 5% .25W	01607	CB1015
A1 R213, R214	0683-1136	2	RESISTOR 11K +-5%	01121	CB1135
A1T1	9100-0657	1	TRANSFORMER POWER CONVERTER	28480	9100-0657
A1U1	1826-0310	6	IC LIN 5C81871G	04713	MC3476G
A1U2	1820-0046	2	IC CD4001AE	02735	CD4001AE
A1U3	1820-0223	1	IC LM301AH	27014	LM301AH
A1U4, U5	1820-0839	3	IC CD4013AE	02735	CD4013AE
A1U6	1820-0940	1	IC CD4011AE	02735	CD4011AE
A1U7	1820-1601		IC CD4070BY	02735	CD4070BY
A1U8	1820-0844	1	IC CD4025AE	02735	CD4025AY
A1U9	1820-0846		IC CD4011AE	02735	CD4001AE
A1U11	1820-1230	1	IC MK5007N	50088	MK5007N
A1U15-U19	1826-0310		IC LIN MC3476G AMPL	04713	MC3476G
A1Y1	0410-0505	1	CRYSTAL, QUARTZ 100KHZ 0.1%	28480	0410-0505
A1A1	03465-81901		SWITCH ASSEMBLY	28480	03465-81901
A1A1C50	0160-4475	1	CAPACITOR -FXD .1UF 10% 630VDC	28480	0160-4475
A1A1H10	0767-0273		RESISTOR 301K 1% 125W	24546	C4-1.8-TO 3011-F
A1A1W1	03465-81601	1	CABLE, SWITCH	28480	03465-81601
	1200-0770	1	A1 ASSEMBLY MISCELLANEOUS PARTS	28480	1200-0770
	1460-1485	1	SOCKET -XTAL 2-CONT HC-8.U-PKG	28480	1460-1475
			SPRING, FUSE		
C55*	0140-0209	1	PADDING LIST FOR C55*		
	0160-0206		CAPACITOR FXD 5PF +-10% 500VDC MICA	72136	DM15C06K0500NVICR
			CAPACITOR FXD 10PF +-5% 500VDC MICA	28480	0160 0205
R70*	0767-0453	1	PADDING LIST FOR R70*		
	0600-4504		RESISTOR FXD 301K 125W	24546	C4-1.8-TO-3012-F
	0698-3682		RESISTOR FXD 69.8K 125W	24546	C4-1.8-TO 6982-F
	0698-4489		RESISTOR 41.2K 1%, 125W F TC=0+-100	03292	C4-1.8-TO-4122-F
			RESISTOR 26K 1%, 125W F TC=0+-100	03292	C4-1.8-TO-2602-F
A2	03465-66623	1	PC ASSEMBLY DISPLAY INTERFACE	28480	03465-66623
A 2C1	0160 0106	1	CAPACITOR -FXD 60UF +-20% 6VDC TA-SOLID	56289	150D06AX00682
A 2C2					
A 2C2	1251-4484	1	CONNECTOR STRIP, 21-PIN	28480	1251-
A 2L1	0170 0894	1	CORE-SHIELDING BEAD	02114	56 590 85-4A6
A 2P1	1251-4166	1	PC BD CONNECTOR, RECTANGULAR	28480	1251-4166
A 2Q1, Q2	1854-0071	15	TRANSISTOR NPN SI	28480	1854-0071
A 2Q4	1853-0016	4	TRANSISTOR PNP SI	28480	1853-0016
A 2Q5	1854-0071		TRANSISTOR NPN SI	28480	1854-0071
A 2Q6	1853-0016		TRANSISTOR PNP SI	28480	1853-0016
A 2Q7	1854-0071		TRANSISTOR NPN SI	28480	1854-0071
A 2Q8	1853-0016		TRANSISTOR PNP SI TO-02	28480	1853-0016
A 2Q9	1854-0071		TRANSISTOR NPN SI	28480	1854-0071
A 2Q10	1853-0016		TRANSISTOR PNP SI TO 02	28480	1853-0016
A 2Q11	1854-0071		TRANSISTOR NPN SI	28480	1854-0071
A 2Q14-Q21	1854 0071		TRANSISTOR NPN SI	28480	1854-0071
A 2Q22	1854-0647	1	TRANSISTOR NPN 2N3726 SI	01295	2N3726
A 2Q23	1854 0071		TRANSISTOR NPN SI	28480	1854-0071
A 2R1	0683-1025	2	RESISTOR 1K 5% .25W	01121	CB1025
A 2R2	0683-6636		RESISTOR 56K 5% .25W	01121	CB5635
A 2R4	0683-1025		RESISTOR 1K 5% .25W	01121	CB1025
A 2R5	0683-6636		RESISTOR 56K 5% .25W	01121	CB5635
A 2R7	0683-1825	2	RESISTOR 18K 5% .25W	01607	CB1825
A 2R9	0683-1625		RESISTOR 1600 5% .25W	01121	CB1625
A 2R10-R14	0683-7515		RESISTOR 750 5% .25W	01121	CB7515
A 2R15-R18	0683-2025		RESISTOR 2K 5% .25W	01121	CB2025
A 2R22-R25	0683 1215	11	RESISTOR 120 5% .5W	01121	CB1215
A 2R26	0683-3035		RESISTOR 30K 5% .25W	01121	CB3035
A 2R27	0683-2035		RESISTOR 20K 5% .25W	01121	CB2035
A 2R28	0683-1215		RESISTOR 120 5% .25W	01121	CB1215
A 2R29	0683-3035		RESISTOR 30K 5% .25W	01121	CB3035
A 2R30	0683-2035		RESISTOR 20K 5% .25W	01121	CB2035
A 2R31	0683-1215		RESISTOR 120 5% .25W	01121	CB1215
A 2R32	0683-3035		RESISTOR 30K 5% .25W	01121	CB3035
A 2R33	0683-2035		RESISTOR 20K 5% .25W	01121	CB2035
A 2R34	0683-1215		RESISTOR 120 5% .25W	01121	CB1215
A 2R35	0683-3035		RESISTOR 30K 5% .25W	01121	CB3035
A 2R36	0683-2035		RESISTOR 20K 5% .25W	01121	CB2035
A 2R37	0683-1215		RESISTOR 120 5% .25W	01121	CB1215
A 2R38	0683-3035		RESISTOR 30K 5% .25W	01121	CB3035
A 2R39	0683-2035		RESISTOR 20K 5% .25W	01121	CB2035
A 2R40	0683-1215		RESISTOR 120 5% .25W	01121	CB1215
A 2R41	0683-3035		RESISTOR 30K 5% .25W	01121	CB3035

Table 6-3. Replaceable Parts

Reference Designation	HP Part Number	Qty	Description	Mfr Code	Mfr Part Number
A 2R42	0683-2035		RESISTOR 20K 5% .25W	01121	CB2035
A 2R43	0683-1215		RESISTOR 120 5% .25W	01121	CB1215
A 2R44	0683-3035		RESISTOR 30K 5% .25W	01121	CB3035
A 2R45	0683-2035		RESISTOR 20K 5% .25W	01121	CB2035
A 2R46	0683-2035		RESISTOR 20K 5% .25W	01121	CB2035
A 2R47	0608-4475		RESISTOR 0.75K 1% .125W	03868	PM555-1.8-T0-0751-F
A 2R48	0757-0273		RESISTOR 3.01K 1% .125W	24546	C4-1.8-T0-3011-F
A 2R49	0683-0336		RESISTOR 3.3 5% .25W	01121	CB0336
A 2R50-R55	0683-2035		RESISTOR 20K 5% .25W	01121	CB2035
A 2R56-R50	0683-3035		RESISTOR 30K 5% .25W	01121	CB3035
A 2R60	0683-1215		RESISTOR 120 5% .25W	01121	CB1215
A 2R70-R73	0767-0081		RESISTOR 475K 5% .25W	26480	0575-0081
A 2U4	1820-0939	1	IC CD4013AE	02735	CD4013AE
A 2U5	1820-1413		IC MC14511CP	04713	MC14511CP
A 2U6	1820-0649		IC CD4011AE	02735	CD4011AE
A3	03465-66518	1	BATTERY AND CHARGER ASSEMBLY	26480	03465-66518
A3B1	00091-50013	1	BATTERY PACK NICAD CUSTOMER ACCESSORY NO. 82033A	26480	00091-60013
A3C1	0180-2605	1	CAPACITOR-FXD 02UF 25V	76480	0180-2605
A3C2	0180-0210	1	CAPACITOR-FXD 3.3UF 15V	56289	160D335X10015A2
A3CR1	1906-0069	1	DIODE BRIDGE	26480	1906-0069
A3F1	2110-0311	1	FUSE .062A 5B	26480	2110-0311
A3Q1	1854-0701	1	TRANSISTOR NPN	26480	1854-0701
A3Q2	1854-0071	1	TRANSISTOR NPN	26480	1854-0071
A3R1	0757-0389	1	RESISTOR 33.2 OHM 1%	24546	C4-1.8-T0-33R2-F
A3R2	0683-8105	1	RESISTOR 51 OHM .25W	01121	CB5105
A3R3	0683-0275	1	RESISTOR 2.7 OHM .25W 5%	01121	F827G5
A3R4	0683-1015	1	RESISTOR 100 OHM .25W 5%	01121	CB1015
A3R6	0757-0410	1	RESISTOR 301 OHM 1%	24546	C4-1.8-T0-301R-F
A3T1	9100-3407	1	POWER TRANSFORMER	26480	9100-3407
	03465-01201		PC BOARD BRACKET (A3)	26480	03465-01201
	03465-24102		INSULATOR, TRANSFORMER	26480	03465-24102

Table 6-1. Replaceable Parts(Cont'd)

Reference Designation	HP Part Number	Qty	Description	Mfr Code	Mfr Part Number
A3W2	8120-2609	1	POWER SUPPLY CABLE WITH CONNECTOR CONTACT, BATTERY SPRING	28480	8120-2609
	0363-0112	1		28480	
	2110-0269	2	CLIP, FUSE	28480	2110-0269
A3J1	5040-8013	1	RECEPTACLE, AC POWER	28480	5040-8013
A5	03465-66615	1	LED Display Assembly	28480	03465-66615
A5D51 A5D52 - D56	1900-0632	1	LED DISPLAY 0.3" (POLARITY/OVERRANGE) SEG DISPLAY, 0.3" X 7" (7 SEGMENT) FRONT PANEL	28480	1900-0632
	1900-0631	4		28480	1900-0631
	03465-00201	1		28480	03465-00201
			MISCELLANEOUS PARTS GENERAL		
A5J4, J6 A5J6 F1	5040-8068	2	HOLD SPRING	28480	5040-8068
	5060-7456		JACK, BANANA INPUT (VOMM, COM)	28480	5060-7456
	5060-7455	1	FUSE HOLDER (AMPS INPUT JACK)	28480	5060-7455
	2110-0002	1	FUSE, 2 AMPS NB (AMPS INPUT)	28480	2110-0002
	0370-2625	1	PUSHBUTTON (WHITE)	28480	0370-2625
	0370-2486	1	PUSHBUTTON (GREY)	28480	0370-2486
	4040-1133	1	SHELL, TOP	28480	4040-1133
	5040-8136	4	SPACER	28480	5040-8136
	03465-00616	1	SHIELD, TOP	28480	03465-00616
	03465-00611	1	SHIELD, BOTTOM	28480	03465-00611
	4040-1134	1	SHELL, BOTTOM	28480	4040-1134
	5040-7223	2	PAD, NON SKID	28480	5040-7223
	7120-5402	1	LABEL, BOTTOM	28480	7120-5402
	6040-8058	1	HANDLE, BAIL	28480	6040-8058
7120-5370	2	LABEL (PUSH TO ROTATE)	28480	7120-5370	
7120-5401	1	LABEL, REAR	28480	7120-5401	
7120-6188	1	LOGO, FRONT PANEL	28480	7120-6188	
8120-2339	1	CABLE, 21 PIN RIBBON (DISPLAY)	28480	8120-2339	
8120-2591	1	TEST LEAD SET	28480	8120-2591	
03465-90012	1	OPERATING AND SERVICE MANUAL	28480	03465-90012	

SECTION VII TROUBLESHOOTING AND CIRCUIT DIAGRAMS

7-1. INTRODUCTION.

7-2. This section of the manual contains troubleshooting information, the functional block diagram and circuit diagrams for the Multimeter. The troubleshooting paragraphs are divided into three parts:

- a. Preliminary troubleshooting
- b. Analog troubleshooting
- c. Digital troubleshooting

Additional troubleshooting information is located on the block diagram and individual circuit diagrams in the form of dc voltage levels and notes.

7-3. SCHEMATIC DIAGRAMS.

7-4. The schematic diagrams (Figure 7-2 through Figure 7-5) contained in this section illustrate the circuits of the Multimeter. Components marked with an asterisk are those that are critical in value. Some of these "starred" components are part of an adjustment procedure. A method for selecting the correct value is outlined in the adjustment procedures of Section V, if service in these circuit areas is required.

WARNING

Maintenance procedures of Sections V and VII are intended for qualified service personnel only. To reduce the possibility of electrical shock, only qualified personnel are to perform maintenance duties.

7-5. PRELIMINARY CHECK.

7-6. Visual Inspection.

7-7. Record all observances of all function and range malfunctions. Verify that the leads interconnecting the input jacks with the AI board are securely fastened at both ends. Look for obvious cracked, broken, or burned components.

7-8. PRELIMINARY TROUBLESHOOTING.

7-9. Providing the functional checks mentioned in the previous section has been performed, the tests of this section may be unnecessary. This would be the case if the fault is unique to any function, range or combination thereof treated in the Signal Conditioning Section. It should be

obvious that if the fault is uncommon to all functions, the *Signal Conditioning* block is probably the culprit. An exception would be a problem in the switch contacts located in the A/D converter.

7-10. If the malfunction is common to all functions the first check is to verify the operation of all *Power Supply* voltages. The most critical supply in terms of tolerance is the +10 V. If the multimeter's accuracy is out of specification across all functions, check the +10 V and adjust if necessary. See the Power Supply Adjustment section of the manual. If any of the supplies are inoperative, go to the Power Supply section of this guide.

7-11. Analog/Digital Isolation.

7-12. If the supplies are proper, place the meter in the 2 V dc range. Connect a jumper from pin 7 of J1 (the number 1 end is identified with a dot on the PC board) to the CP test point (next to the crystal). The display should read +1.0000. If it does not, the fault is in the *Control Logic*, *Display Interface* or *Display*. Go to the Digital Troubleshooting section. If the display is proper, remove the jumper and go to the Analog Troubleshooting section.

7-13. ANALOG TROUBLESHOOTING.

7-14. Analog Isolation.

7-15. It should be mentioned here that if the problem is unique to any function, that particular portion of the *signal conditioner* should already have been cleared. If the malfunction is common to ac and dc volts or common to the ac volts and ac current, refer to the *Signal Conditioning Section*.

7-16. With the instrument still in the 2 V dc range, short the input and monitor the voltage at the DCTP terminal. The voltage should be less than 1 mV. Now apply +1 V dc to the input and monitor the same point with an oscilloscope. The waveform should look like the following:

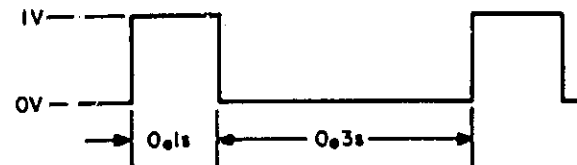

If either of these stipulated conditions are not met, the fault is probably in the *input amplifier*. A further check of the input amplifier is to vary the input voltage level. The peak value of the rectangular wave should follow the input.

7-17. If the 300 ms segment is extended a permanent "overrange" condition exists. Check the *Auto Zero* and *Reference Supply* circuits. With 1 V dc still applied to the input, check the waveform at the COMP/CP terminal. The waveform should look like the following:

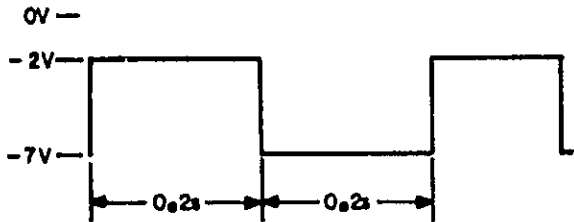

The width of the A segment will vary proportionally as the input amplitude is varied. If this signal and stipulations are not met, the fault is in the *Analog-to-Digital Converter*. (Remember, the logic section has already been cleared or the Control State Counter could also cause problems here.) The noise that appears in the comparator off state is just that and can be ignored.

7-18. Power Supply Faults.

NOTE

In protecting batteries and circuitry, the low battery voltage detection circuit may shut down the instrument if the power switch is momentarily turned off then back on. To restore normal operation, the instrument must be turned off by the front panel switch for a minimum of 3 seconds.

7-19. Verify the supply voltages in the following sequence:
+ V_B , + 10 V and - 7 V.

a. The + V_B supply should indicate between + 3 V dc and + 6 V dc. The voltage should be present in both the ON and OFF positions of the front panel power switch. The "on" reading may be slightly lower than the "off" reading.

b. If at least + 3 V is not indicated in the "on" position, the problem is in the primary power source. Check the A3 board batteries and power line.

c. If both the + 10 V and - 7 V supplies are also inoperative, proceed as follows.

1. Check C18, CR19 and CR20 for shorts.
2. Check the voltage across R99 (with a floating meter). 300 mV is typical. 500 mV or more indi-

cates that the - 7 V supply is excessively loaded. If this is the case, lift the various - 7 V jumpers. Lift the jumpers one at a time, while monitoring the supply, until all jumpers are up. This will isolate the fault if it is in the loading.

3. Check the waveform at the base of Q33. The Waveform should be similar to the illustration below.

Reference level should be approximately $V_B - .7$ volts. The collector of Q33 should be a non-symmetrical square wave of at least 13 volts peak-to-peak with the approximate 10 μ s period.

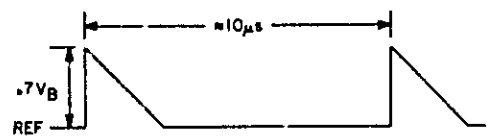

4. If the waveforms are not present, continue to monitor and proceed through the following. If at any step a fault is detected and corrected and the waveforms appear, go to Step 5.

(a) Lift R112 at the junction of U17, pin 6, and connect it to + V_B . If waveforms appear, the fault is with U17 or CR36.

(b) Lift Q38. If waveforms appear, the fault is in the low battery voltage detection circuit.

(c) Lift Q35. Waveforms? Yes? Q35 is at fault.

If the above procedures do not restore the required waveforms, the fault is with Q33, Q34 or T1.

5. Lift R112 at the junction of U17, pin 6, and connect it to an external supply. Adjust the supply (not to exceed + 6 V dc) until + 11 volts is measured across C26.

(a) Momentarily short emitter to collector of Q27. If the voltage at the + 10 V test point comes up, the fault is in the + 10 V regulator. Check R75, U16, Q27, Q26 and CR17 in that order. If the voltage does not come up, isolate the troubled area by lifting the + 10 V jumpers, one at a time, and proceed to the relevant circuit if the + 10 V is restored.

7-20. Signal Conditioning Faults.

7-21. AC/DC Volts – Common Fault. If the fault is common only to the ac and dc volt function, check the input attenuator and associated switches.

7-22. AC Volts/AC Current Common Fault. The most expedient way to check out the impedance and ac/dc converters is to trace the input signal through with an oscilloscope. With 1 V ac applied to the input in the 2 V ac range, the following are normal.

a. The waveform on U19, pin 3, and C49 should be the same as the input or about 3 volts peak-to-peak.

b. At the ACTP test point, the amplitude should be about twice the input or about 6 volts peak-to-peak with a dc offset of + 1.6 volts.

c. The signal at the junction of R100 and R118 should be a half wave rectification of the signal seen in (B).

d. The voltage across C38 should be about 0.75 volts dc.

e. If one-half full scale readings are alright but full scale is in error, check C41 for leakage.

f. Out-of-spec readings could be caused by leakage in the filter capacitors C36, C37 and C38. This condition can be readily checked by applying an external 1 V dc at the junction of R100 and R118 and verifying 1 V dc across C38.

g. If an inaccuracy is unique to the 500 V range, check R75.

7-23. AC/DC Current Common Fault. Check AMPS fuse, and check that contact is being made through the terminal fuse spring to the PC board.

7-24. AC Current. If the fault is unique to ac current, check R20 and R39.

7-25. Ohms. Short the junction of C29 and R78 (Q25A gate) to ground. Rotating R69 (20 M Ω adj.) through its extremes should result in the output (pin 6) of U15 to span the voltage range of about - 2.5 V dc to + 10 V dc. This establishes that Q25 and U15 are functional. Reset R69 in accordance with the prescribed adjustment procedure of the manual.

a. Depress the Ω and 20 m buttons, and short the input Ω and COM terminals. If the instrument stops sampling or the front panel count is greater than ± 15 counts, check the ohms calibration.

b. If the 200 Ω range zero is out of tolerance (± 3 counts) check C31 for leakage.

c. If all readings are progressively increasing out of spec as the measured resistance is increased, check diodes (particularly CR15, CR24, CR25 and CR26) and capacitors C29 and C31 for leakage.

7-26. Analog-to-Digital Converter Faults.

7-27. The *Input Amplifier* was basically treated in the general isolation section. If the problem is attributed to the input amplifier, the fault can be further localized as follows:

a. Short the IO signal at the input of U2 to ground. (The instrument is now locked in the run-up phase.) Monitor the voltage at the DCTP point. The dc level should be essentially zero with the input shorted and should vary proportionally to 2 V as the instrument's input is varied to full scale of any particular range. If it does not, the fault is forward of the DCTP point and then proceed to Step b, otherwise, go to Paragraph 7-29.

b. Short the input gate of Q16 (coming from Q20) to ground. With the instrument on the 2 V range, check the dc voltage at the DCTP point. It should be less than 1 mV. If it is not, short U1 pins 2 and 3 together. If the voltage has not essentially zeroed, check U1. If the latter did zero the DCTP voltage, check Q16 and/or adjust R50 to yield the desired less than 1 mV offset.

7-28. The outputs of U1 should also be verified in the normal running mode. The waveforms should appear as:

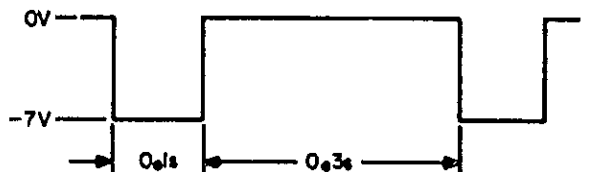

at U2 pin 4, and



at U2 pin 3. If the IO control signal is present and either of these are incorrect, check U2, Q19 and Q20.

7-29. Integrator/Slope Amplifier/Comparator/Auto-Zero.

7-30. Proceed as follows to ascertain the condition of the integrator, slope amplifier, comparator, and auto-zero circuits.

a. Apply +1 V dc to the input on the 2 V dc range. Check the waveform at *jumper A*. An easy access point is the proper end of C19. The signal should appear as shown below.

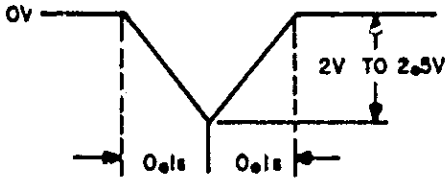

b. The signal at the base of Q9 should appear as follows.

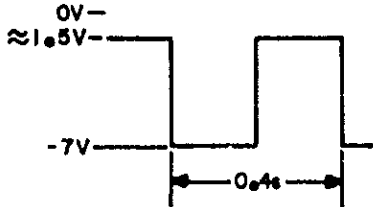

c. The signal at the COMPTP test point should appear as follows.

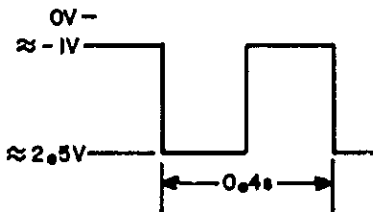

d. The signal at AZTP should be the following.

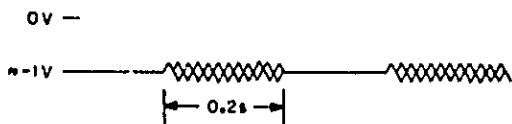

e. The switching of the Auto Zero circuit controls the pulsing of the A/D loop. If it is malfunctioning, check the IZ signal from the Control State Decode, Q1 and Q2.

NOTE

If the IZ signal and Auto Zero circuit are proper, troubleshoot the circuit immediately before an improper waveform is detected.

f. Short point RS to ground.

g. Measure the voltage at AZTP. If the voltage is about -1 V, the fault is probably in the *Reference Supply*; if not, the fault is within the loop.

h. Place the instrument in any ohms range and apply -7 volts at the junction of R56 and R57. (The internal supply may be used.) The voltage at jumper A should now be about +9.5 volts, the voltage at COMPTP should be near zero, and the voltage at the COMP terminal should be about -1 volt.

i. Now apply +10 volts at the R56/R57 junction and the respective measured voltages should be about -6.5, -2, and -6.

NOTE

If any of the test voltages are incorrect, troubleshoot the circuit immediately forward of the first bad reading. If all voltages test good, the fault is probably in the Auto Zero Circuit.

7-31. Digital Troubleshooting.



This instrument contains CMOS Digital IC's and, therefore, is highly susceptible to failure due to static discharge. Extra handling precautions should be used when servicing circuit areas containing these devices.

7-32. Place the ANALOG/DIGITAL isolation jumper connection between test points CP and PL with FUNCTION and RANGE settings of DCV and 200 m, respectively. The first indication that the display section is operating properly will be a display of

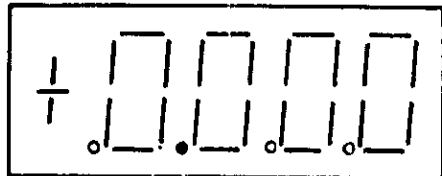

with the plus/minus indicator flashing at the 1.25 Hz rate. If the display is dim or blank, check A2C1, and A2Q21 through Q23. If the display indicated above is not obtained, the logic or display circuitry is at fault.

NOTE

Throughout the digital troubleshooting section, maintain the ANALOG/DIGITAL ISOLATION JUMPER in the CP - PL position unless instructed otherwise.

7-33. **Display and Display Driver Verification.** This test checks the display, display drivers, and BCD decoders on the A2 display interface board. It does not check any mother board circuitry. Implement the test as follows:

a. Connect test points -7 and test point LT located on the A2 display board.

b. Verify display. If all drivers and LED segments are operating properly, the display will show

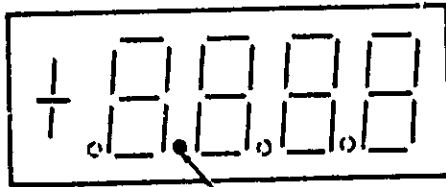

NOTE
Position of the decimal point will be dependent on the range selected.

c. To check the overrange digit, disconnect one end of the ANALOG/DIGITAL ISOLATION JUMPER and short pin 7 of the display connector J1 to test point CP with the instrument in the 2 V dc range. The display should indicate

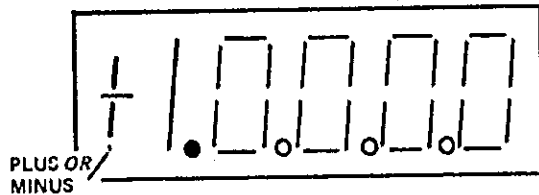

If the display reads properly in steps b and c, replace the ANALOG/DIGITAL ISOLATION JUMPER connection between test points CP and PL. Otherwise, the failure can be determined by symptoms and the use of that portion of schematic 3 which shows the A2 display interface board. If correct displays were obtained in steps b and c above, but an incorrect display was indicated in paragraph 7-32, some portions of the mother board logic are faulty.

7-34. Mother Board Digital Circuitry Troubleshooting. The following paragraphs provide a systematic method for troubleshooting the mother board digital circuitry. (For best results, the step should be followed in order.)

7-35. Maintain the ANALOG/DIGITAL ISOLATION JUMPER between test points CP and PL. Begin by checking the clock frequency at test point CL:

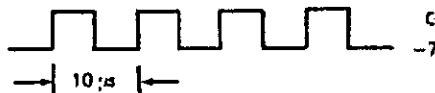

It is essential the clock frequency be verified. An incorrect clock frequency can make U11 appear defective.

7-36. Verify that U11 is receiving a clock at pin 7. Then, check for TXFR and RESET signals at U11:

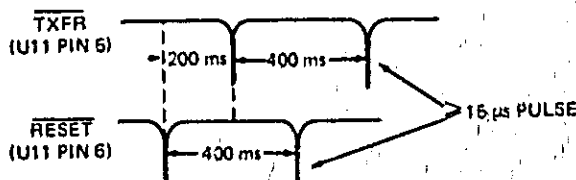

If the above signals are present, but the display of paragraph 7-32 is not indicated, U11 is probably defective.

7-37. If TXFR or RESET is not correct, check for COUNT EXTEND at U11 pin 8 and the STATE CLOCK at U6 pin 10:

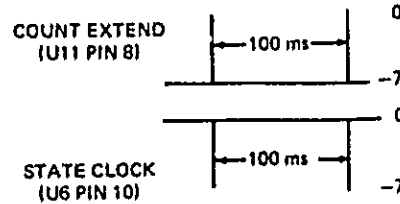

a. If there is no COUNT EXTEND, ground U11 pins 5 and 6. If COUNT EXTEND does not appear, U11 is defective. If COUNT EXTEND is present, but the STATE CLOCK is not, replace U6.

b. If the STATE CLOCK is present, lift A1CR5 and observe the display for the one indicated in paragraph 7-32. If it appears, the control state counter is operating properly.

c. If the display of paragraph 7-32 is not indicated, check A1CR5, and return it to its original position if it is not defective. (The display can also be affected by timing capacitors C3, C8, C9 and C110 through C112.) Check each flip-flop in the Control State Counter to verify that $D = Q$, and the Q and \bar{Q} are in opposite states. Ground the RESET line and verify that all Q = -7 volts and $\bar{Q} = 0$ volts. At the same time, observe if the outputs are in an "illegal state;" high outputs should be within 50 millivolts of ground and low outputs should be within 50 millivolts of the -7 volt bus.

7-38. Check test point PL for the following waveform:

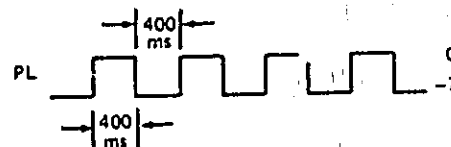

Make certain that high and low states are within 50 millivolts of ground and -7 volts, respectively. If the proper waveform is not present, check for an illegal state at U7 pins 1 or 2. An illegal state indicates a faulty U7. If replacing U7 does not correct the problem replace U4.

7-39. The following test checks gates in the Data Transfer and Reset section by manually setting a value at test point TC.

a. Connect pin 3 of display connector J1 to test point TC.

b. Alternate the function between DCV and ACV. This switches the voltage at test point TC between ground and -7 volts.

c. While changing functions between DCV and ACV, transitions should be observed at the following points:

IC	Pin
U6	3
U7	4
U7	11
U9	4

If any of these transitions is not observed, or if the output falls into an illegal state, the associated chip should be replaced. Note that none of the above tests have checked the control state decoding section. Outputs should be compared to those shown below. All of the above tests may pass even if these gates are bad.

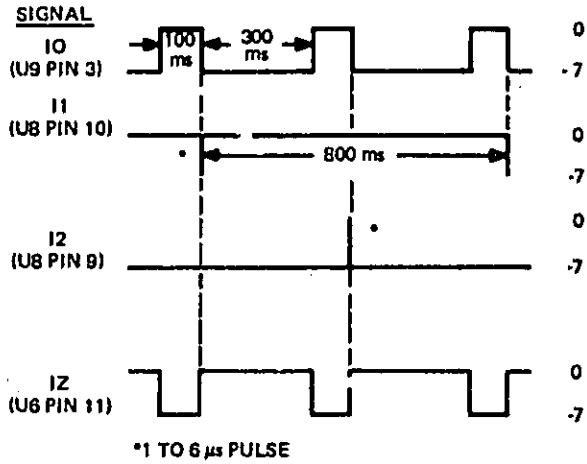

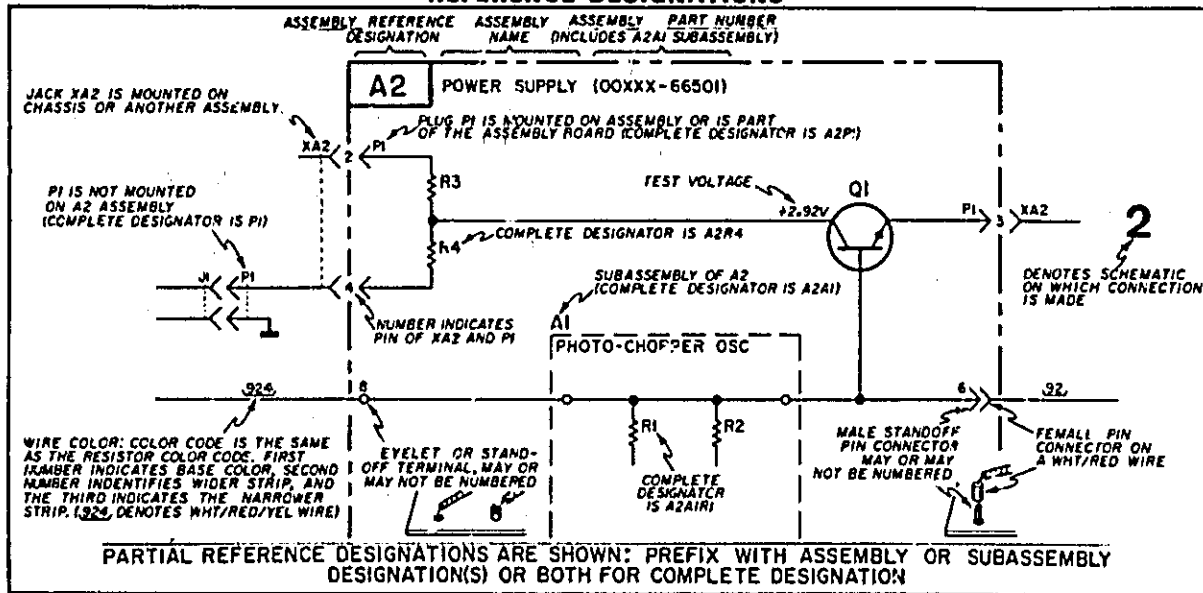

REFERENCE DESIGNATIONS



GENERAL SCHEMATIC NOTES

1. PARTIAL REFERENCE DESIGNATIONS ARE SHOWN. PREFIX WITH ASSEMBLY OR SUBASSEMBLY DESIGNATION(S) OR BOTH FOR COMPLETE DESIGNATION.
2. COMPONENT VALUES ARE SHOWN AS FOLLOWS UNLESS OTHERWISE NOTED.
RESISTANCE IN OHMS
CAPACITANCE IN MICROFARADS
INDUCTANCE IN MILLIHENRYS
3.  DENOTES FRAME OR SHIELD GROUND. USED FOR TERMINALS WHICH ARE PERMANENTLY CONNECTED WITHIN APPROXIMATELY 0.1 OHM OF EARTH GROUND.

 DENOTES GROUND ON PRINTED CIRCUIT ASSEMBLY.

5.  DENOTES ASSEMBLY.

6.  DENOTES FRONT PANEL MARKING.

7.  DENOTES REAR PANEL MARKING.

8.  DENOTES SCREWDRIVER ADJUST.

9. * AVERAGE VALUE SHOWN, OPTIMUM VALUE SELECTED AT FACTORY. THE VALUE OF THESE COMPONENTS MAY VARY FROM ONE INSTRUMENT TO ANOTHER.

10.  DENOTES SECOND APPEARANCE OF A CONNECTOR PIN.

11. 924 DENOTES WIRE COLOR: COLOR CODE SAME AS RESISTOR COLOR CODE. FIRST NUMBER IDENTIFIES BASE COLOR, SECOND NUMBER IDENTIFIES WIDER STRIP, THIRD NUMBER IDENTIFIES NARROWER STRIP. (e.g., 924 - WHITE, RED, YELLOW.)

12. DC VOLTAGE LEVELS WERE MEASURED WITH RESPECT TO CIRCUIT GROUND USING A DVM WITH 10 MEGOHM INPUT IMPEDANCE. THE VOLTAGE LEVELS SHOWN ARE NOMINAL AND MAY VARY FROM ONE INSTRUMENT TO ANOTHER DUE TO CHANGE IN TRANSISTOR CHARACTERISTICS. A VARIATION OF ± 10% SHOULD BE ALLOWED.



DENOTES BUFFER

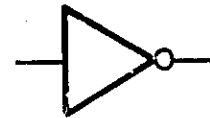

DENOTES INVERTER



DENOTES AND GATE

A	B	C	Q
0	0	0	0
0	0	1	0
0	1	0	0
0	1	1	0
1	0	0	0
1	0	1	0
1	1	0	0
1	1	1	1

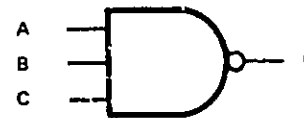

DENOTES NAND GATE

A	B	C	Q
0	0	0	1
0	0	1	1
0	1	0	1
0	1	1	1
1	0	0	1
1	0	1	1
1	1	0	1
1	1	1	0



DENOTES NOR GATE

A	B	C	Q
0	0	0	1
0	0	1	0
0	1	0	0
0	1	1	0
1	0	0	0
1	0	1	0
1	1	0	0
1	1	1	0

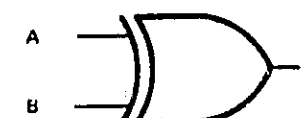

DENOTES EXCLUSIVE OR GATE

A	B	Q
0	0	0
0	1	1
1	0	1
1	1	0

3485B Jumper Locator.

Designator	Schematic	Board Coordinates	Description
1	4	C5	+ 10 V Supply Coarse
2	4	C5	Adjustment
4	4	C5	Adjustment
8	4	C5	Adjustment
16	4	C5	Adjustment
J1	4	D11	Supplies A1 Board Isolation
J2	4	A9	-7 V to AC Converter
J3	4	E7	+ 10 Volt to Low Battery Voltage Detection Circuit
J4	4	E7	+ 10 V to Ω and AC Converter
J5	4	E7	+ 10 V to DC Input Amp and Integrator
J6	4	D7	-7 V to Ω Converter
J7	4	B10	-7 V to Logic, Low Battery Voltage Detection Circuit
J8	4	E10	-7 V to Logic
J9	4	E7	-7 V
J10	4	H7	-7 V to Slope Amp
J11	1	A6	AC Converter Gain Adj
J12	1	A6	AC Converter Gain Adj
JA	2	7G	Integrator Output
JB	2	C6	2 k Ω Coarse Adjustment
JC	2	F7	R75, Pin 26 Access
JH	2	E5	Input Amp Coarse Gain Adj
JR	4	B5	10 V Reference Coarse Gain Adj

Test Points and Pads.

-7 V	4	C9	Power Supply Verification
+ 11 V	4	C9	Power Supply Verification
+ 10 V	4	E7	Power Supply Verification
VB	4		Power Supply Verification
+3	3	A2 Board	Power Supply Verification
ACTP	1	H7	Output of AC Converter Gain Stages, Input to AC Converter Rectifier
AZTP	2	H7	Auto Zero Voltage
CL	3	F11	Clock
CP	3	G:1	Comparator and Test Input to Logic
COMP	4	G11	Comparator Output
COMP TP	2	H7	Comparator Input
DCTP	2	H5	Input Amplifier Output
GND	A11	D7	Ground
L1	3	A2 Board	LAMP TEST
PL	3	G11	Polarity Logic
RS	3	F11	Reset Pulse
TC	3	EL	Transfer Completed.

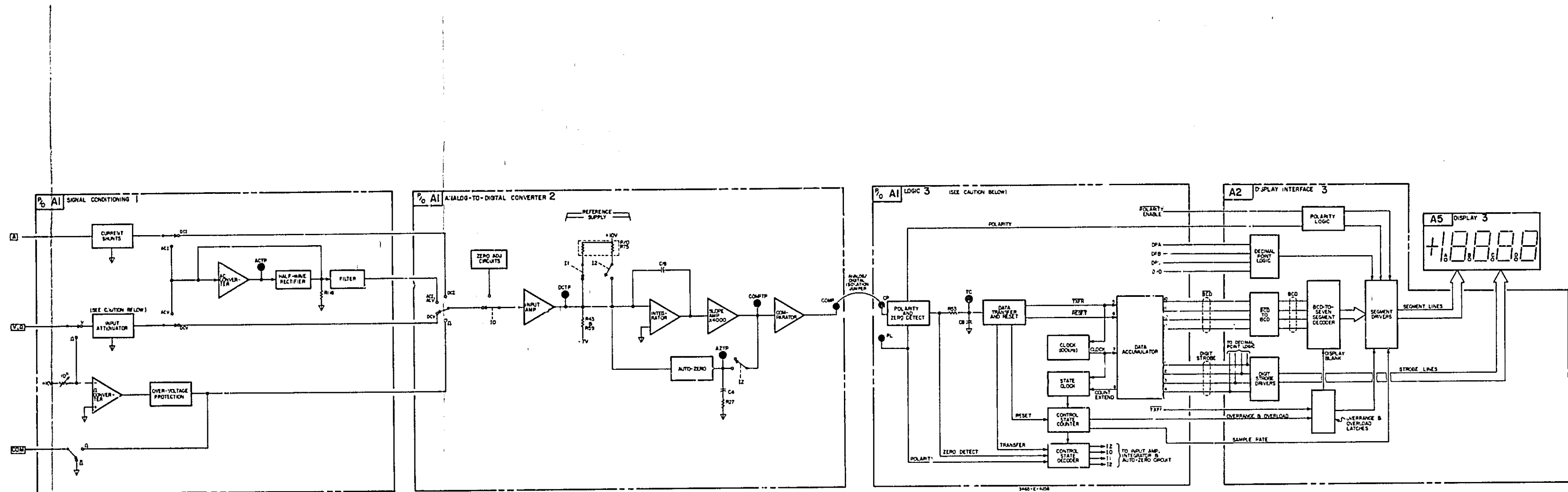

CAUTION

INPUT ATTENUATOR 20 PIN CERAMIC PRECISION RESISTOR PACK (R175) MUST BE KEPT FREE OF DIRT, GRAPE OR SOLDER FLUX. THESE CONTAMINANTS CAN BE ASSORBED INTO THE CERAMIC PACKAGE RESULTING IN A DEGRADATION OF THE MULTIMETER'S ENVIRONMENTAL SPECIFICATION. USE CLEAN HANDLING PROCEDURES IF THIS COMPONENT REQUIRES SERVICING (DO NOT TOUCH CERAMIC CASE WITH BARE HANDS).

CAUTION

THIS INSTRUMENT CONTAINS CMOS DIGITAL IC'S AND THEREFORE IS HIGHLY SUSCEPTIBLE TO FAILURE DUE TO STATIC DISCHARGE. EXTRA HANDLING PRECAUTIONS SHOULD BE USED WHEN HANDLING OR SERVICING CIRCUIT AREAS CONTAINING THESE DEVICES.

Figure 7-1. Functional Block Diagram.

A1
-hp- Part No. 03465-66531

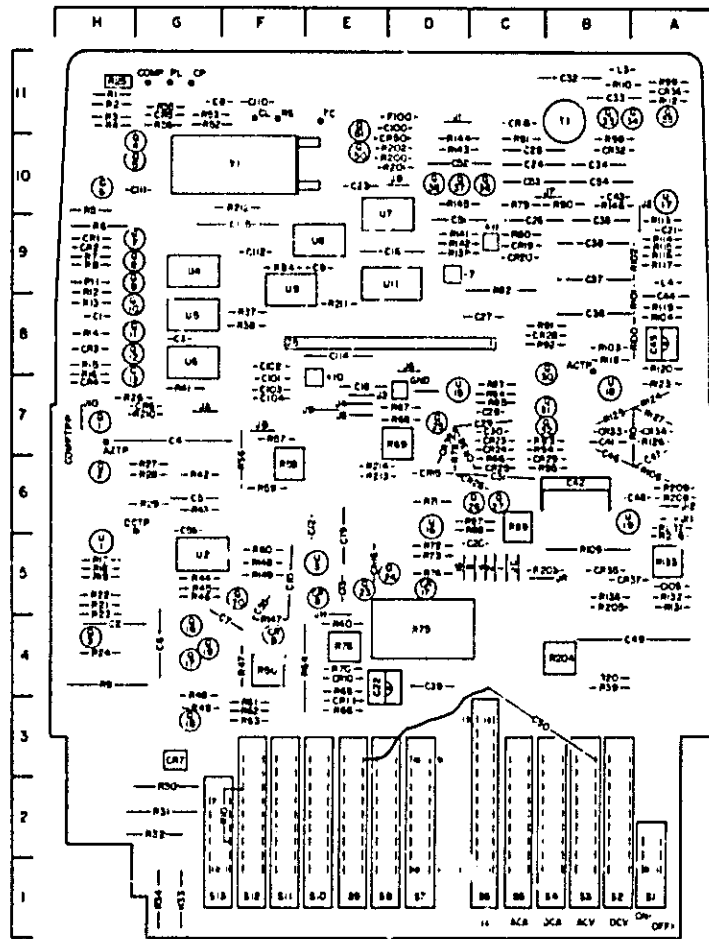

Coordinated Component Locator Index

ion	R	U	Ref Desig Suffix	Grid Location			
				C	C9	Q	R
H11	H5	28	C7	B8			G6
H11	G5	29	C7	B6			G6
H11	G5	30	C7			C8	G2
H11	G9	31	C6			C7	G2
H10	G8	32	B11	B10		C7	G2
H9	G8	33	B11	B7	B11		G1
H9	D9	34	C10	A7	A11		G1
H9	E9	35	B9	B5	A11		G11
H4	F9	36	B8	A11	C10		G11
F2		37	B9	A5	D10		F8
H9	D9	38	B9	C7	D10		F8
H9		39		D7			B4
H8		40					E4
H8		41	B7				G7
H8	D7	42	B6				G6
H8	D6	43	B10				G6
H5	A10	44	A8				G5
H5	B7	45	A8				G5
H5	B6	46	B6				G5
B4		47	A6				F4
H5		48	A6				G4
H5		49	A4				G4
H5		50	C3	D10	E10		F4
H4		51	D9				
H11		52	D10				G11
H7		53	C10				G11
G6		54	B10				F9

Ref Desig Suffix	Grid Location		Ref Desig Suffix	Grid Location		Ref Desig Suffix	Grid Location		Ref Desig Suffix	Grid Location	
	C	H		C	R		C	H		C	R
85	F5		82		C9	109		B5	136		
86	G6		83		C7	110	F11	G11	137		
87			84		C7	111	G10		138		
88			85		C7	112	F9	A11	139		D9
89			86		C6	113		A9	140		
90			87		CE	114	EB	A9	141		D9
91			88		C5	115	F9	A9	142		D9
92			89		C5	116		A9	143		D10
93			90		B10	117		A9	144		D10
94			91		B8	118		B8	145		D10
95			92		B8	119		A8	146		B10
96			93		B7	120		A8	147		F4
97			94		B7	121			148		F5
98			95		B6	122			149		F5
99			96			123		A7			
100			97			124		A7	200		D10
101			98		B10	125		B7	201		D10
102			99		A11	126		A7	202		D10
103			100		AB	127		A7	203		C5
104			101	D11	AB				204		B4
105			102		F8	A5			205		B5
106			103		F7	B8			206		AL
			104		F7	A8			207		A6
			105	A5				A5	208		A6
			106		A6			A5	209		A6
110						135		B5	210		G7
111									211		E8
112									212		F10
113									213		E6
114									214		E6

A1
hp-Part No. 03465-66631

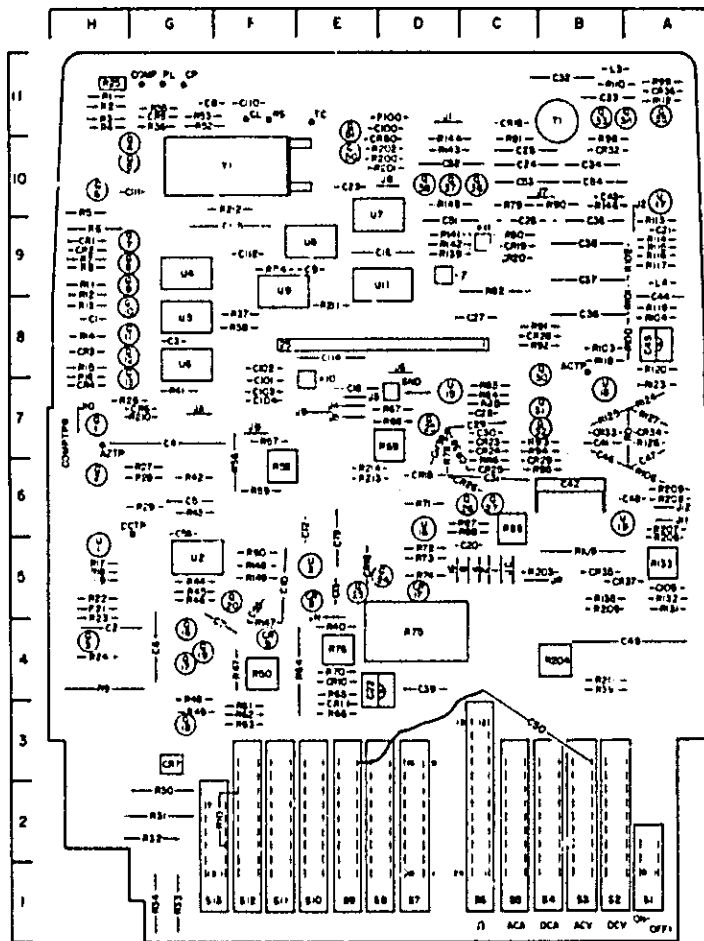

Coordinated Component Locator Index

Ref Design Suffix	Grid Location	Grid Location					
		C	CR	Q	R		
H11	H5	28	C7	B8		G6	
H11	G5	29	C7	B5		G6	
H11	E5	30	C7		C8	G2	
H11	G9	31	C6		C7	G2	
H10	G8	32	B11	B10	C7	G2	
H9	G8	33	B11	B7	B11	G1	
H9	D9	34	B10	A7	A11	G1	
H9	E9	35	B9	B5	A11	G11	
H4	F9	36	B8	A11	C10	G11	
F2		37	B9	A5	D10	F8	
H9	D9	38	B9	C7	D10	F8	
H9		39		D7		B4	
H8		40				E4	
H8		41		B7		G7	
H8	D7	42	B6			G6	
H8	D6	43	B10			G6	
H5	A10	44	A8			G5	
H5	B:	45	A8			G5	
H5	B6	46	B6			G5	
B4		47	A6			F4	
H5		48	A6			F4	
H5		49	A4			G4	
H5		50	C3	D10	E10	F4	
H4		51	O9		E11	F4	
H11		52	D10			G11	
H7		53	C10			G11	
G6		54	B10			F9	

Ref Design Suffix	Grid Location	Ref Design Suffix	Grid Location		Ref Design Suffix	Grid Location		Ref Design Suffix	Grid Location	
			C	R		C	R		C	R
55	F5	82		C9	103	B5	136			
56	G6	83		C7	110	B11	137			
57		84		C7	111	G10	138			
58		85		C7	112	F9	139			D9
59		86		C6	113	A9	140			
60		87		C6	114	E8	A9	141		O9
61		88		C6	115	F9	A9	142		O9
62		89		C6	116		A9	143		D10
63		90		B10	117		A9	144		D10
64		91		B8	118		B8	145		D10
65		92		B8	119		A8	146		B10
66		93		B7	120		A8	147		F4
67		94		B7	121			148		F5
68		95		B6	122			149		F5
69		96			123		A7			
70		97			124		A7	200		D10
71		98			125		B7	201		D10
72		99		B10	126		A7	202		D10
73		100	D11	A8	127		A7	203		C5
74		101	F0	A8				204		B4
75		102	F8	A9	129			205		B5
76		103	F7	B8	130			206		A6
77		104	F7	A8	131			207		A6
78		105	A5		132		A5	208		A6
79		106		A6	133		A5	209		A6
80										
81		C9			135		B5	210		G7
		C10						211		E8
								212		F10
								213		E6
								214		E6

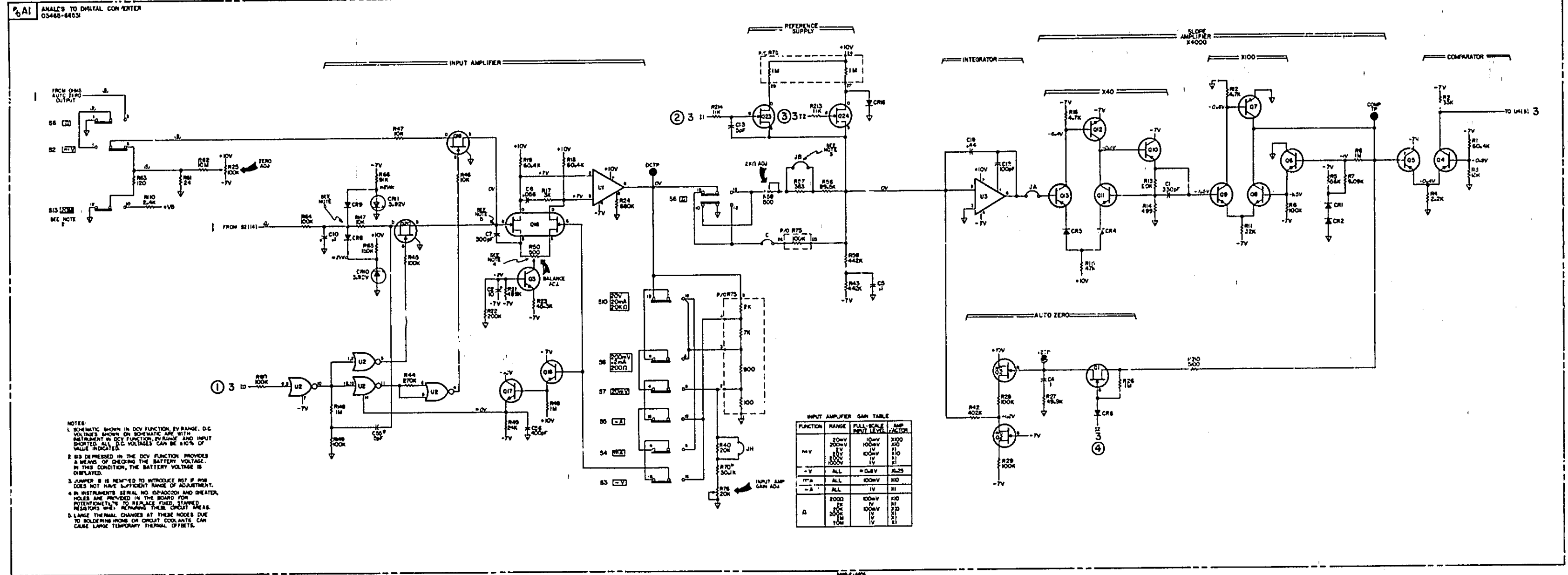
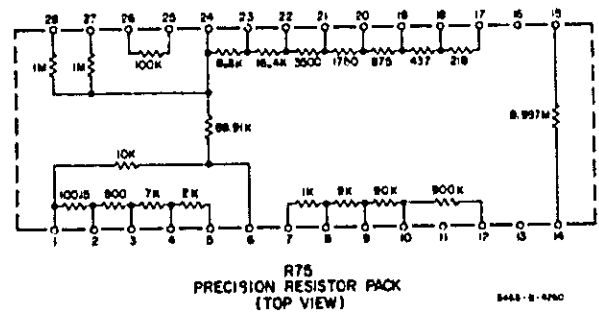

2
Figure 7-3. Analog-to-Digital Converter.
7-13

A1
 hp- Part No. 03468-66531

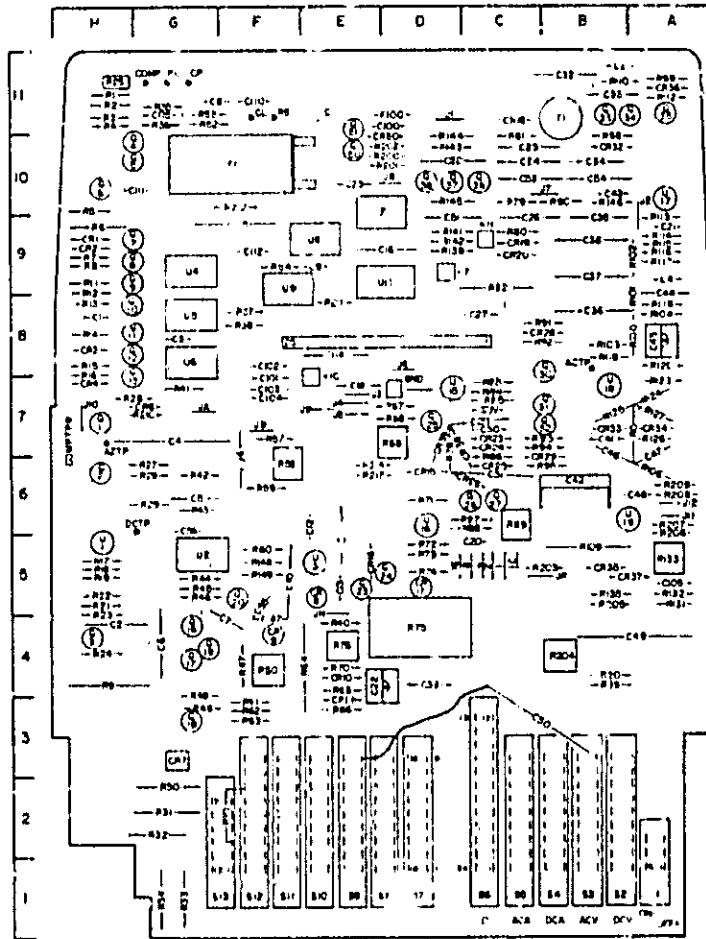

Coordinate Component Locator Index

R	U	Ref Desig Suffix	Grid Location			
			C	CR	Q	H
H11	H5	28	C7	B8		G6
H11	G5	29	C7	B6		G6
H11	E5	30	C7		C9	G2
H11	G9	31	C6		C7	G2
H10	Ge	32	B11	B10	C7	G2
H9	G8	33	A11	B7	B11	G1
H9	D9	34	B10	A7	A11	G1
H9	E9	35	R9	B5	A11	G11
H4	F9	36	B6	A11	C10	G11
F2		37	U9	A5	D O	F8
H9	D9	38	B9	C7	D10	F8
H9		39		D7		B4
H8		40				E4
H8		41	B7			G7
H8	D7	42	B6			G6
H8	DE	43	E10			G6
H5	A10	44	A8			G5
H5	B7	46	A8			G5
H5	BE	46	B6			G5
B4		47	A6			F4
H5		48	A6			G4
H5		49	A4			G4
H5		50	C3		E10	F4
H4		51	D9		E11	
H11		52	D10			G11
H7		53	C10			G11
G6		54	B10			F4

Ref Desig Suffix	Grid Location		Ref Desig Suffix	Grid Location		Ref Desig Suffix	Grid Location		Ref Desig Suffix	Grid Location	
	C	R		C	R		C	R		C	R
55	F5		82		C9	109		B5	136		
56	G6		F6		C7	110	F11	B11	137		
57			F7		C7	111	G10		138		
58			F6		C7	112	F9		139		D9
59			F6		C5	113		A9	140		
60			F5		C6	114	E8	A9	141		D9
61			F3		C6	115	F9	A9	142		D9
62			F3		C6	116		A9	143		D10
63			F3		B10	117		A9	144		D10
64			F4		B8	118		B8	145		D10
65			E4		B8	119		A8	146		B10
66			E3		B7	120		A3	147		
67			D7		B7	121			148		F5
68			D7		B6	122			149		F5
69			D7		B6	123		A7			
70			E4			124		A7	200		D10
71			D6		B10	125		B7	201		D10
72			D5		A11	126		A7	202		D10
73			D5		A5	127		A7	203		C5
74			D5	D11	B8				204		B4
75			D4		F8	A9	129		205		B5
76			E4		F7	B8	130		206		A6
77					F7	A8	131	A5	207		A6
78			D7		A5		132	A5	208		A6
79			C10		A6		133	A5	209		A6
80			C9				135	B5	210		G7
B1			C10						211		F10
									212		F10
									213		E6
									214		E6

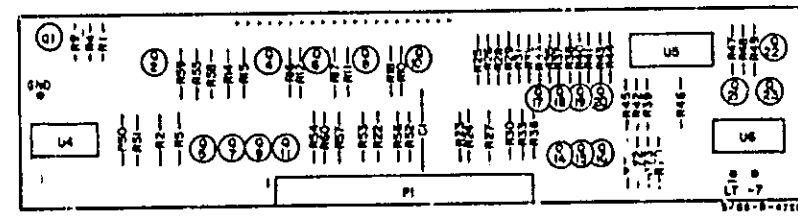

A2
-hp- Part No. 03465-66532

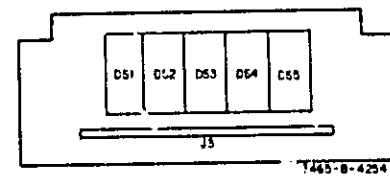

A5
-hp- Part No. 03465-66515

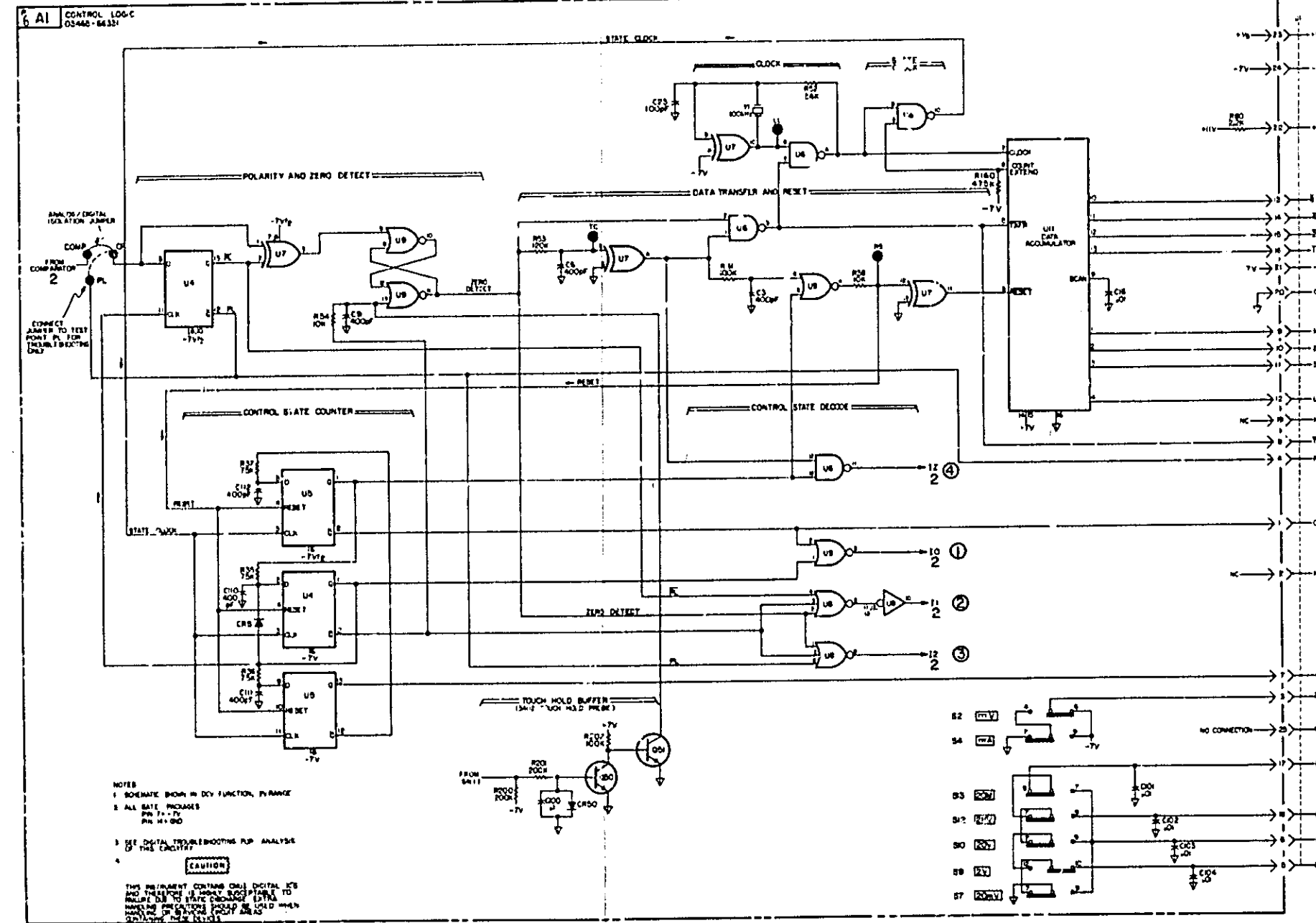

NOTES
 1 SCHEMATIC SHOWN IN DCY FUNCTION, IN RANGE
 2 ALL SATE INCREASES
 PA 14-75
 PA 14-80
 3 SEE DIGITAL TROUBLESHOOTING PUP ANALYZER
 4 THIS FACILITY

CAUTION
 THIS EQUIPMENT CONTAINS ONLY DIGITAL IC'S
 AND THEREFORE THE NORMAL LOGIC TO
 BE USED FOR TROUBLESHOOTING IS THE
 DIGITAL LOGIC. THE LOGIC SHOULD BE USED ONLY
 FOR TROUBLESHOOTING PURPOSES.

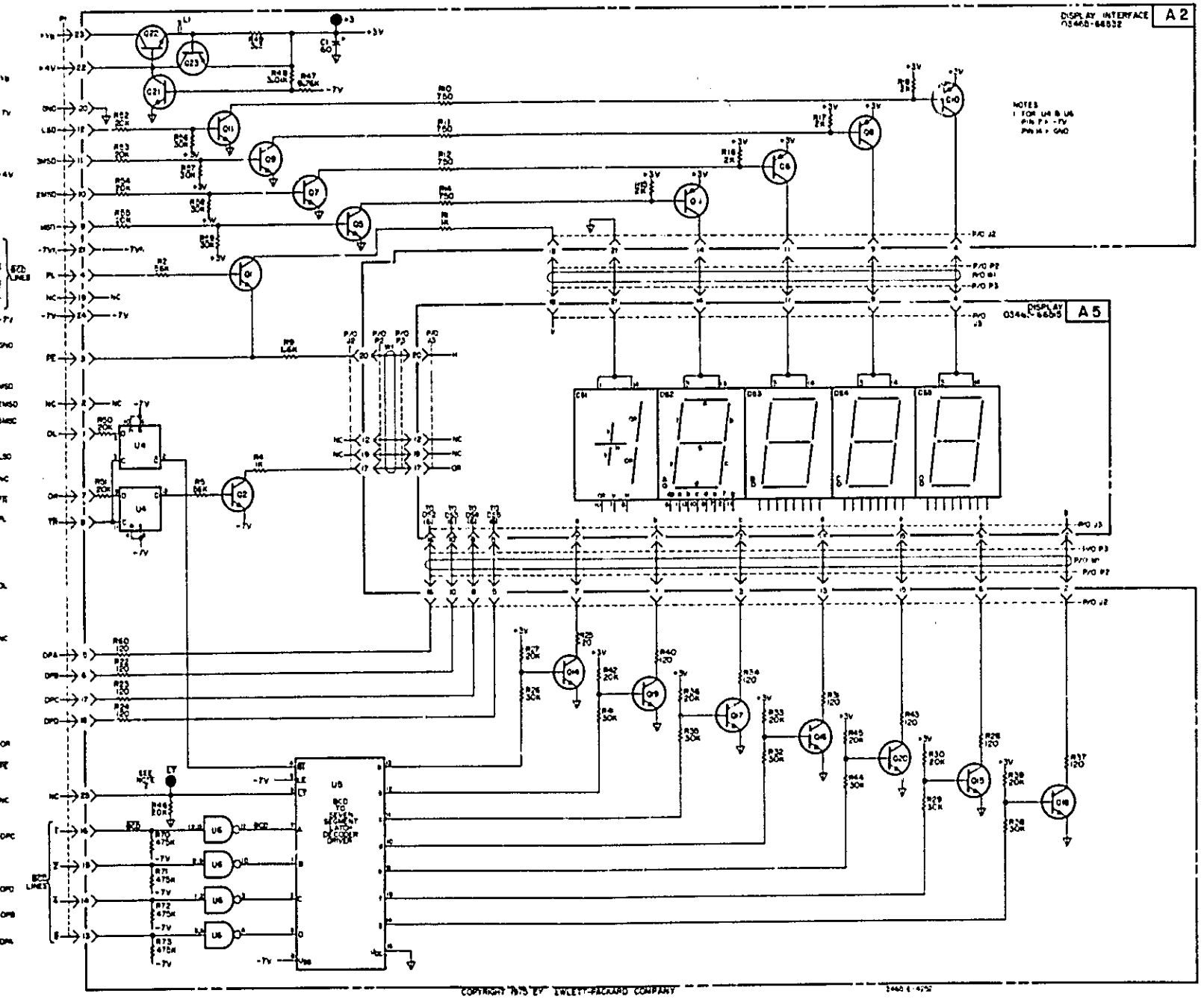

3
 Figure 7-4. Logic and Display.
 7-15

A1
hp- Part No. 03465-66631

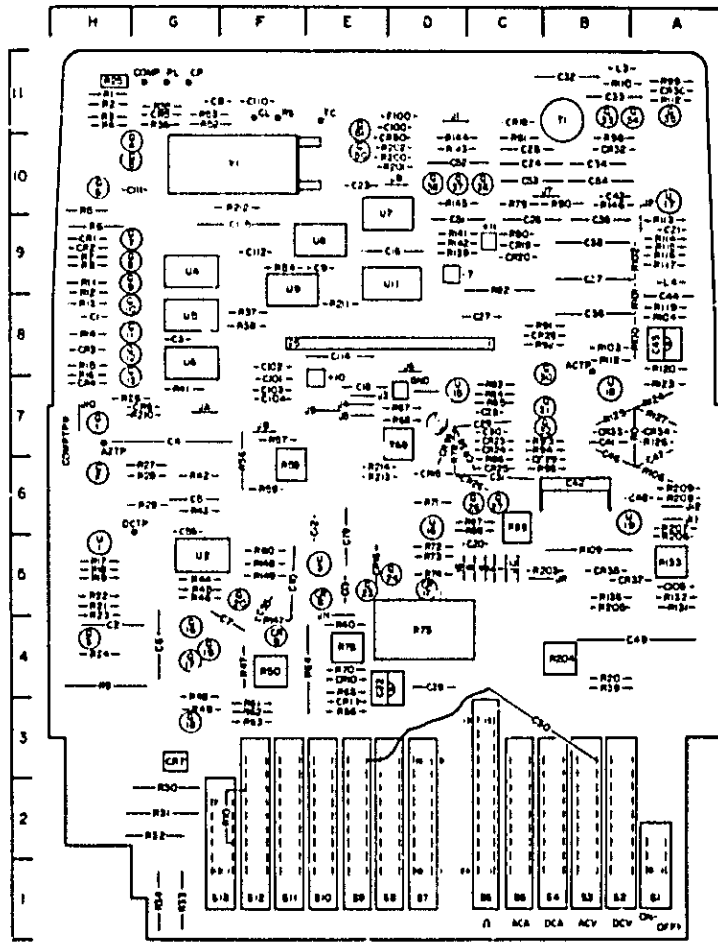

Coordinated Component Locator Index

Row	Col	Ref Desig Suffix	Grid Location			
			C	CR	O	R
H11	H5	28	C7	B8		G6
H11	G5	29	C7	B6		G6
H11	E5	30	C7		CH	G2
H11	G9	31	C6		C7	G2
H10	G8	32	B11	B10	C7	G2
H9	G8	33	B11	B7	B11	G1
H9	D9	34	B10	A7	A11	G1
H9	E9	35	B9	B5	A11	G11
H4	F9	36	B8	A11	C10	G11
F2		37	B9	A5	D10	F8
H9	D9	38	B9	C7	D10	F8
H9		39		D7		B4
H8		40				E4
H8		41	B7			G7
H8	D7	42	B6			G6
H8	D6	43	B0			G6
H5	A10	44	A8			G5
H5	B7	45	A8			G5
H5		46	B6			G5
B4		47	A6			F4
H5		48	A6			G4
H5		49	A4			G4
H5		50	C3	O10	E10	A4
H4		51	D9		E11	A4
H11		52	D10			G11
H7		53	C10			G11
G6		54	B10			F9

Ref Desig Suffix	Grid Location		Ref Desig Suffix	Grid Location		Ref Desig Suffix	Grid Location		Ref Desig Suffix	Grid Location	
	C	R		C	R		C	R		C	R
55	F5		82	C9		109	F11	B5	136		
56	GG		83	C7		110	G10	B11	127		
57		F6	84	C7		111	F9	A9	138		
58		F6	85	C7		112		A11	139		D9
59		F6	86	C6		113		A9	140		
60		F5	87	C6		114	E8	A9	141		D9
61		F3	88	C6		115	F9	A9	142		D9
62		F3	89	C6		116		A9	143		D10
63		F3	90	B10		117		A9	144		D10
64		F4	91	B9		118		B8	145		D10
65		E4	92	B8		119		A8	146		B10
66		E3	93	B7		120		A8	147		F4
67		D7	94	B7		121			148		F5
68		D7	95	B6		122			149		F4
69		D7	96			123		A7			F4
70		E4	97			124		A7	200		D10
71		D6	98		B10	125		B7	201		D10
72		D5	99		A11	126		A7	202		D10
73		D5	100	D11	A8	127		A7	203		C5
74		D5	101	F8	A5				204		B4
7E		D4	102	F8	A9	129			205		B5
76		E4	103	F7	B8	130			206		A6
77			104	F7	A8	131		A5	207		A6
78		D7	105	A5		132		A5	208		A6
79		C10	106	A6	A6	133		A5	209		A6
80									135		B5
B1		C9							210		G7
		C10							211		E8
									212		F10
									213		E6
									214		E6

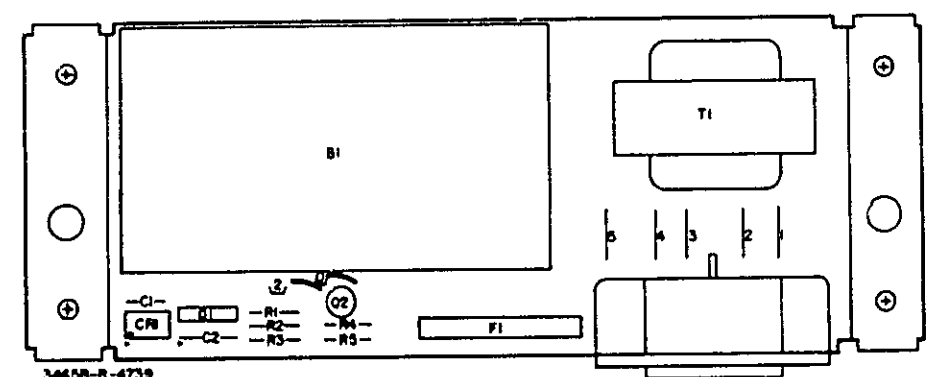
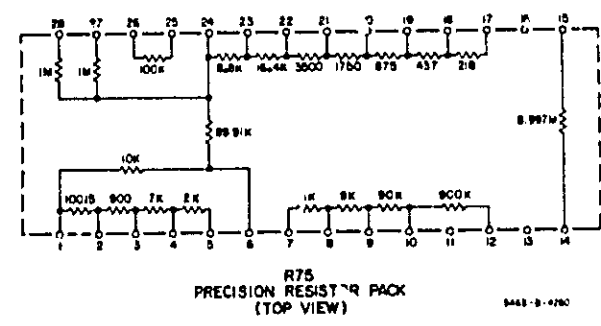

A3
-hp Part No. 03465-66516

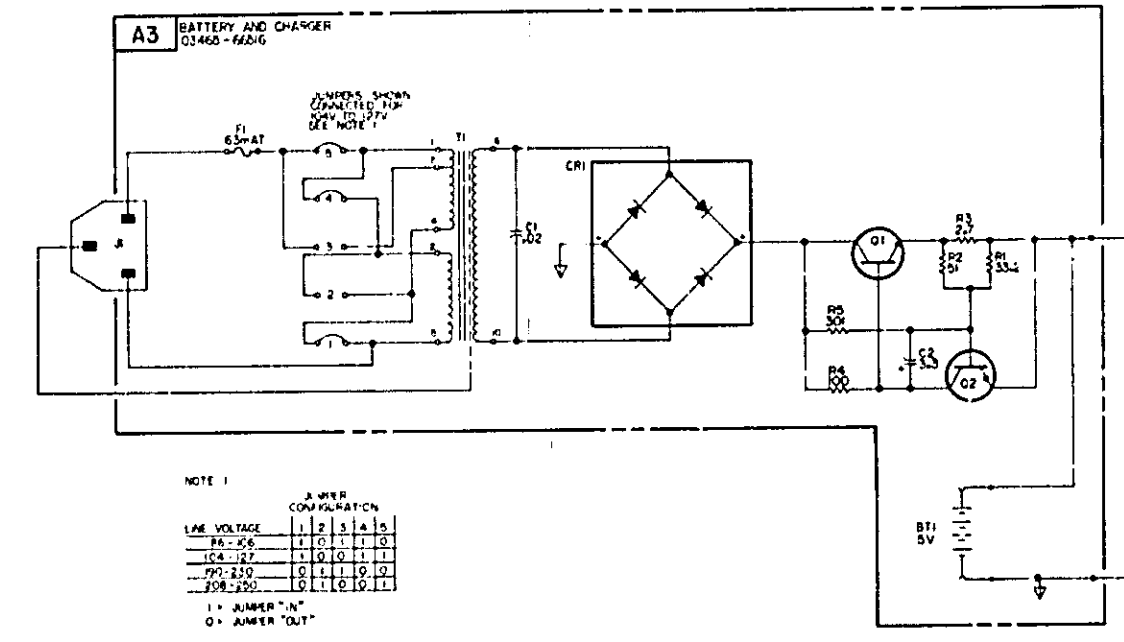

NOTE 1

LINE VOLTAGE	1	2	3	4	5
BA-256	1	0	1	1	3
CA-127	1	0	1	1	1
PP-210	0	1	1	1	0
PP-190	1	1	0	1	1

1 = JUMPER "IN"
0 = JUMPER "OUT"

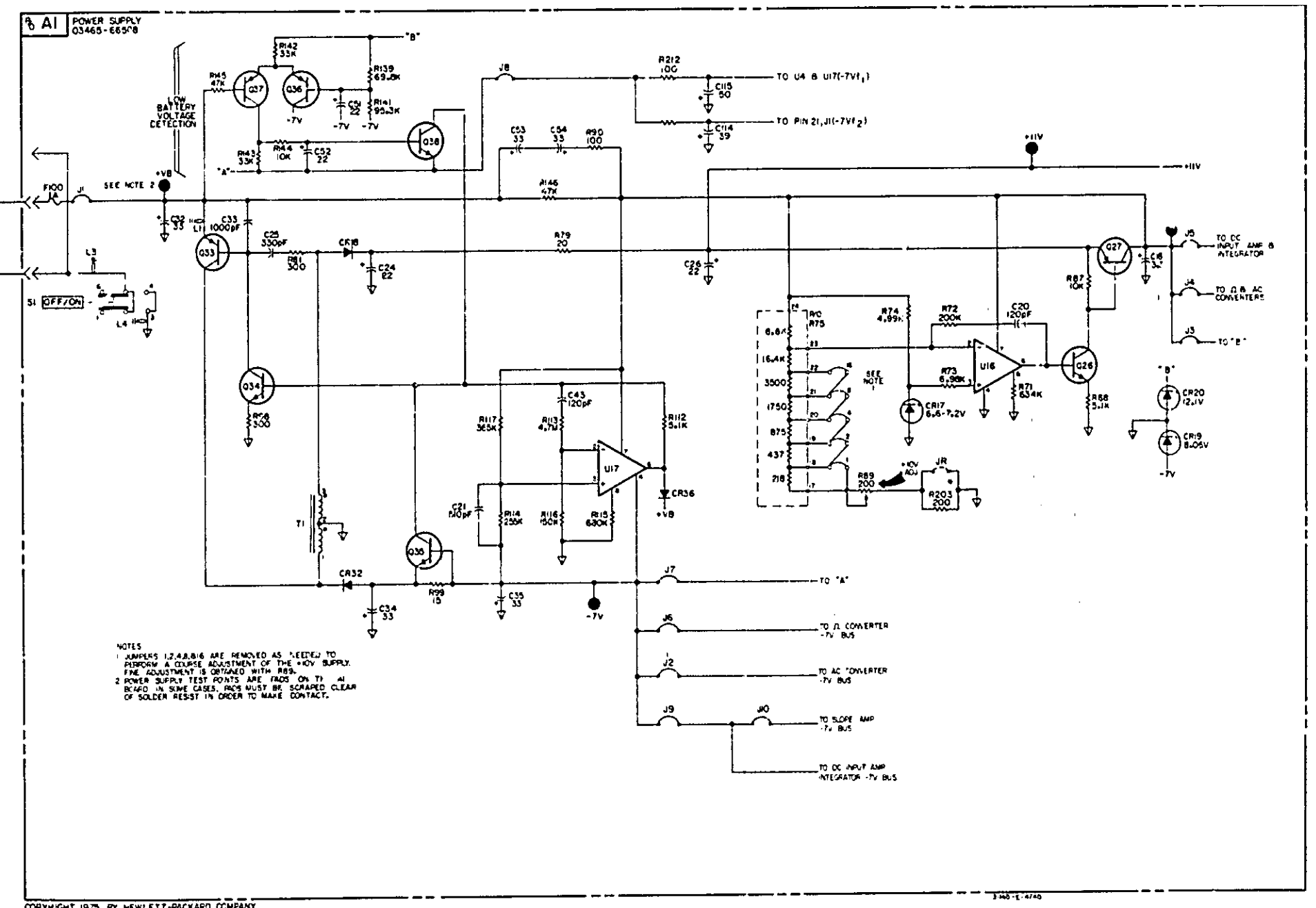

NOTES
1. JUMPERS J1, J2, J3, J4, J5, J6 ARE REMOVED AS NEEDED TO PERFORM A COURSE ADJUSTMENT OF THE +10V SUPPLY. FINE ADJUSTMENT IS OBTAINED WITH R88.
2. POWER SUPPLY TEST POINTS ARE PRODS ON T1 BEARD IN SOME CASES. PRODS MUST BE SCRAPED CLEAR OF SOLDER RESIST IN ORDER TO MAKE CONTACT.

COPYRIGHT 1975 BY HEWLETT-PACKARD COMPANY

3445-1-4745

4
Figure 7-5. Power Supply.
7-177-18

hp MANUAL CHANGES

-hp- MODEL 3465B

MULTIMETER

Manual Part Number 03465-90012

■ New or Revised Item

ERRATA.

Page 5-2, Table 5-3. Delete the existing Table 5-3 and add the following Table 5-3.

Table 5-3. DC Ammeter Accuracy Test.

Multimeter Range	Current Level	R _A	3455A VM Reading	Multimeter Display Limits
200 μ A	10 μ A	100 k Ω \pm 0.01%	1.0000 V	9.98 - 10.02 μ A
	50 μ A		5.0000 V	49.95 - 50.05 μ A
	100 μ A		10.000 V	99.92 - 100.08 μ A
2 mA	.1 mA	1 k Ω \pm 0.01%	.10000 V	.0998 - .1002 mA
	.5 mA		.50000 V	.4995 - .5005 mA
	1 mA		1.0000 V	.9992 - 1.0008 mA
20 mA	1 mA	1 k Ω \pm 0.01%	1.0000 V	.998 - 1.002 mA
	5 mA		5.0000 V	4.993 - 5.007 mA
	10 mA		10.000 V	9.988 - 10.012 mA
200 mA	10 mA	10 Ω \pm 0.01%	.10000 V	9.93 - 10.07 mA
	50 mA		.50000 V	49.69 - 50.31 mA
	100 mA		1.0000 V	99.39 - 100.61 mA
2000 mA	100 mA	1 Ω \pm 0.02%	.10000 V	99.3 - 100.7 mA
	500 mA		.50000 V	496.9 - 503.1 mA
	1000 mA		1.0000 V	993.0 - 1006.1 mA

Page 5-5, Paragraph 5-18 "AC Normal Mode Rejection Test", Section F.

Delete Section F and replace with:

1. Repeat Steps c, d and e for an ac calibrator output frequency of 50 Hz \pm .1% as monitored by the electronic counter.

CHANGE NO. 1 applies to all Serial Numbers.

Page 1-2, Table 1-1, Specifications. Change AC AMMETER Accuracy Graph to the following:

CURRENT INPUT FREQUENCY	Accuracy	Accuracy
20kHz	\pm 0.6% Reading + 15 digits)	
10kHz	\pm (.25% Reading + 5 digits)	\pm (.65% Reading + 5 digits)
1kHz	\pm (.4% Reading + 5 digits)	\pm (.8% Reading + 5 digits)
40Hz		

CURRENT RANGE

Page 5-7, Table 5-3. Change description of A3, -hp- Part Number 03465-66516 from BATTERY AND CHARGER ASSEMBLY to:

BATTERY CHARGER ASSEMBLY.

Page 5-7, Table 5-3. Change description for Part Number 00091-60013 from BATTERY PACK NICAD CUSTOMER ASSESSORY NO. 82033A to:

BATTERY PACK NICAD FOR CUSTOMER, USE ACCESSORY NO. 82033A

Page 5-7, Table 5-3. Add to Replaceable Parts:

-hp- Part No.	Qty	Description
1460-1559	1	Extention Spring for Battery Holder
0363-0112	2	Battery Contact Spring

CHANGE NO. 2

Add HP p/n 1251-4822, A1J2, 3 pin connector, Mfr. Code 28480, Mfr. Part Number 1251-4822, quantity 1, to table 6-3 on page 6-3.

Page 5-4, Table 5-3. Change designator A1Q16 -hp- part number from 1855-0222 to 1855-0243.

Figure 7-3, Page 7-13. A1C13 on schematic should be shown as a 2pF capacitor, not a 5pF capacitor.

Figure 7-2, Page 7-11. Change A1C57* to A1C39* on schematic.

Table 6-3, Page 6-3. Change A1CR23 to the following:

hp Part Number	Description	Mfr Part Number
1902-0057	DIODE-ZNR 5.49V 5% DO-7 TC = +.029	1902-0057

Table 6-3, Page 6-5. Change the A1R160 part number from 0757-0081 to 0757-0481.

Page 7-10. Add A1R160 to the 03465-66531 Component Layout.

Add A1R160 to the Coordinated Component Locator Index.

Page 7-12. Add A1R160 to the 03465-66531 Component Layout.

Add A1R160 to the Coordinated Component Locator Index.

Page 7-14. Add A1R160 to the 03465-66531 Component Layout.

Add A1R160 to the Coordinated Component Locator Index.

Page 7-16. Add A1R160 to the 03465-66531 Component Layout.

Add A1R160 to the Coordinated Component Locator Index.

Table 6-3, Page 6-7. Change the -hp- part number of A2R70-73 from 0757-0081 to 0757-0481, and Mfr Part Number from 0575-0081 to 0757-0481.

Table 1-1, Page 1-2. Change the DC Voltmeter specification for AC Normal-Mode Rejection from >60dB at 50/60 Hz \pm .1% to >54dB at 50/60 Hz \pm .1%.

Paragraph 5-20, Page 5-5. Alter paragraph "e" to read: ...Step C. This verifies a normal-mode rejection of greater than 54dB. Also, change the Performance Test Card, page 5-17 to indicate 54dB Normal Mode Rejection.

CHANGE NO. 3 applies to all Serial Numbers.

Page 5-7. Change paragraph to read as follows:

f Change the AC Calibrator frequency to 3183Hz. The multimeter display should indicate .7071 kto 1.0000 verifying a shunt capacitance less than 100pf.

Page 7-1. Paragraph 7-10. Add the following to the end of the paragraph:

Always verify that the battery is fully charged and can supply a minimum current of 200ma at a voltage level of at least 3.67 volts. If the battery does not supply the above requirement, it should be replaced.

Page 6-4, Table 6-3. Change designator A1Q16 -hp- Part Number from 1855-0243 to 1855-0470.

Page 1-2, Table 1-1. Change AC Normal-Mode Rejection from >60dB at 50/60 Hz \pm 0.1% to >54dB at 50/60 Hz \pm 0.1%.

Page 5-5, Paragraph 19e. Change to read the following:

The multimeter indication should not vary more than .007V from the indication noted in Step C. This verifies a Normal-Mode Rejection of greater than 54dB.

Page 5-17, Performance Test Card. Change paragraph number 5-19 to read as follows:

5-19 Normal-Mode Rejection >.007 (54dB)

Free Manuals Download Website

<http://myh66.com>

<http://usermanuals.us>

<http://www.somanuals.com>

<http://www.4manuals.cc>

<http://www.manual-lib.com>

<http://www.404manual.com>

<http://www.luxmanual.com>

<http://aubethermostatmanual.com>

Golf course search by state

<http://golfingnear.com>

Email search by domain

<http://emailbydomain.com>

Auto manuals search

<http://auto.somanuals.com>

TV manuals search

<http://tv.somanuals.com>