

HP 5253B

**INSTRUMENT REPAIR**

**5253B  
FREQUENCY  
CONVERTER**

**OPERATING AND SERVICE MANUAL**

---

HEWLETT  PACKARD

---

HP 5253B

# MANUAL CHANGES

MODEL 5253B

FREQUENCY CONVERTER

Manual Serial Prefixed: 513-  
Manual Printed: NOV 1965

MAKE ALL CORRECTIONS IN THIS MANUAL ACCORDING TO ERRATA BELOW, THEN CHECK THE FOLLOWING TABLE FOR YOUR INSTRUMENT SERIAL PREFIX (3-DIGITS) OR SERIAL NUMBER (8-DIGITS) AND MAKE ANY LISTED CHANGE(S) IN THE MANUAL.

▶ NEW ITEM.

SERIAL PREFIX OR NUMBER	MAKE MANUAL CHANGES	SERIAL PREFIX OR NUMBER	MAKE MANUAL CHANGES

ERRATA

Replace Page 3-1 with new Page 3-1.

Dec 27, 65

Supplement A for  
05253-9006

## SECTION III OPERATION

### 3-1. FRONT PANEL.

3-2. The functions of the front panel control, meter, connector, and retaining screws are given in Figure 3-1.

### 3-3. MAXIMUM INPUT VOLTAGES.

3-4. Damage to the converter may result if an AC signal greater than 2 v RMS or a DC voltage greater than 100 v is applied to converter INPUT connector.

### 3-5. OPERATING PROCEDURES.

#### 3-6. NORMAL RANGE MEASUREMENTS.

3-7. Figure 3-2 is the procedure to be used for measurement of frequencies from 50.1 to 512 Mc with INPUT signal amplitudes from 50 mv to 1 v RMS.

#### 3-8. EXTENDED RANGE MEASUREMENTS.

3-9. The frequency of signals not within the normal range of 50.1 to 512 Mc, 50 mv to 1 v RMS, may be measured using the following procedures:

3-10. 50 TO 50.1 MC, 50 MV TO 1 V RMS. Perform steps 1 through 5 of Figure 3-2. Then:

- a. Set mixing frequency control to slightly more than 60 Mc.
- b. Turn mixing frequency control slowly clockwise until level indicator meter first reaches a maximum reading in the green portion of its scale.
- c. Subtract counter display (in Mc) from reading of mixing frequency control (in Mc) for frequency of INPUT signal.

3-11. 50 TO 512 MC, AMPLITUDE LESS THAN 50 MV RMS. The front panel level indicator meter indicates in the green portion of its scale only when converter is properly tuned and amplitude of INPUT signal is adequate for accurate frequency measurement. However, because of conservative specifications of both the converter and counter, frequencies may often be accurately measured when meter reads in the red portion of its scale. To make these extended range measurements:

- a. Follow normal procedure (Figure 3-2 or Paragraph 3-10, depending upon frequency range) except that mixing frequency control should be tuned for first maximum reading on the level indicator meter, regardless of the color of region maximum.
- b. Check frequency measurement result as described in Paragraph 3-12, or
- c. Insert an external variable attenuator (such as Hewlett-Packard Model 355A or 355C) in the transmission line between the converter and the source of INPUT signal. Vary attenuation from 0 to 1 db during final step of frequency measurement procedure. If counter display does not change more than momentarily (during switching of attenuator), INPUT signal is above noise threshold and frequency measurement result is valid.

### 3-12. DOUBLE-CHECKING FREQUENCY MEASUREMENT RESULT.

3-13. Because of the heterodyne action of the converter, frequency measurement results obtained at any one setting of the mixing frequency control may be checked at other settings. See Figure 3-3 for examples.

Table 3-1. Frequency Resolution

INPUT SIGNAL FREQUENCY = 151.1223344 Mc MIXING FREQUENCY CONTROL set to 140 Mc		
Time Base Setting	Counter Display	Measurement Resolution
.1 $\mu$ s	* (no display)	
1 $\mu$ s	1 1. Mc	1 5 1. Mc
10 $\mu$ s	1 1.1 Mc	1 5 1.1 Mc
.1 ms	1 1.1 2 Mc	1 5 1.1 2 Mc
1 ms	1 1 1 2 2. kc	1 5 1.1 2 2 Mc
10 ms	1 1 1 2 2.3 kc	1 5 1.1 2 2 3 Mc
.1 s	1 1 1 2 2.3 3 kc	1 5 1.1 2 2 3 3 Mc
1 s	1 1 1 2 2.3 3 4 kc	1 5 1.1 2 2 3 3 4 Mc
10 s	1 1 2 2.3 3 4 4 kc	1 5 1.1 2 2 3 3 4 4 Mc

## CERTIFICATION

*The Hewlett-Packard Company certifies that this instrument was thoroughly tested and inspected and found to meet its published specifications when it was shipped from the factory. The Hewlett-Packard Company further certifies that its calibration measurements are traceable to the U.S. National Bureau of Standards to the extent allowed by the Bureau's calibration facility.*

## WARRANTY AND ASSISTANCE

All Hewlett-Packard products are warranted against defects in materials and workmanship. This warranty applies for one year from the date of delivery, or, in the case of certain major components listed in the operating manual, for the specified period. We will repair or replace products which prove to be defective during the warranty period. No other warranty is expressed or implied. We are not liable for consequential damages.

For any assistance contact your nearest Hewlett-Packard Sales and Service Office. Addresses are provided at the back of this manual.



## OPERATING AND SERVICE MANUAL

# MODEL 5253B FREQUENCY CONVERTER

SERIALS PREFIXED: 513-

This manual applies directly to  Model 5253B Frequency Converters having serial number prefix 513-

### OLDER INSTRUMENTS

This manual with changes provided in Appendix I also applies to models having serial prefix numbers 450, 321, and 311

### MODEL 5253A

This manual with information provided in Appendix II also applies to Model 5253A Frequency Converters having serial prefix numbers 238 and 226.

Copyright HEWLETT-PACKARD COMPANY 1963  
1501 PAGE MILL ROAD, PALO ALTO, CALIFORNIA, U.S.A.

## TABLE OF CONTENTS

Section	Page	Section	Page
I GENERAL . . . . .	1-1	V MAINTENANCE (cont'd)	
1-1. Description . . . . .	1-1	5-10. Repair and Replacement . . . . .	5-1
1-5. Specifications . . . . .	1-1	5-12. Printed Circuit Component . . . . .	
1-7. Accessory . . . . .	1-1	Replacement . . . . .	5-3
1-9. Instrument Identification . . . . .	1-1	5-14. Video Amplifier Assembly . . . . .	
1-11. Cooling . . . . .	1-1	Replacement . . . . .	5-3
II PREPARATION FOR USE . . . . .	2-1	5-16. Mixer Diode Replacement . . . . .	5-3
2-1. Unpacking and Mechanical Inspection . . . . .	2-1	5-18. Meter Replacement Procedure . . . . .	5-3
2-3. Electrical Inspection . . . . .	2-1	5-20. Harmonic Generator Adjustment . . . . .	5-4
2-5. Storage and Reshipment . . . . .	2-1	5-22. Low Pass Filter Adjustment . . . . .	5-4
2-8. Installation . . . . .	2-1	5-25. Mechanical Adjustment of Meter	
2-11. Power Requirements . . . . .	2-1	Zero . . . . .	5-5
2-13. Electrical Connections . . . . .	2-1	5-28. Sensitivity Check . . . . .	5-5
III OPERATION . . . . .	3-1	5-29. Meter Accuracy Check . . . . .	5-5
3-1. Front Panel . . . . .	3-1	5-30. Low Pass Filter Check . . . . .	5-5
3-3. Maximum Input Voltages . . . . .	3-1	5-31. In-Cabinet Performance Check . . . . .	5-6
3-5. Operating Procedures . . . . .	3-1	VI REPLACEABLE PARTS . . . . .	6-1
3-6. Normal Range Measurements . . . . .	3-1	6-1. Introduction . . . . .	6-1
3-8. Extended Range Measurements . . . . .	3-1	6-4. Ordering Information . . . . .	6-1
3-12. Double-Checking Frequency		APPENDIX II - Model 5353A	
Measurement Result . . . . .	3-1	IIA-1. Introduction . . . . .	IIA-1
3-14. Aid to Rapid Tuning . . . . .	3-3	IIA-3. Description . . . . .	IIA-1
IV PRINCIPLES OF OPERATION . . . . .	4-1	IIA-7. Operating Procedure . . . . .	IIA-1
4-1. General . . . . .	4-1	IIA-8. Normal Range Measurements . . . . .	IIA-1
4-5. Harmonic Generator (A2, A3), and		IIA-10. Extended Range Measurements . . . . .	IIA-1
Harmonic Selector Cavity . . . . .	4-1	IIA-14. Video Amplifier Assembly (A1) . . . . .	IIA-3
4-7. Mixer (A4) . . . . .	4-2	IIA-16. Level Indicator Meter . . . . .	IIA-3
4-9. Video Amplifier Assembly (A1) . . . . .	4-2	IIA-18. Harmonic Generator Adjustment . . . . .	IIA-3
4-11. Level Indicator Meter . . . . .	4-2	IIA-20. Low Pass Filter Adjustment . . . . .	IIA-3
V MAINTENANCE . . . . .	5-1	IIA-22. Meter Adjustment . . . . .	IIA-3
5-1. General . . . . .	5-1	IIA-23. Mechanical Adjustment of	
5-2. Introduction . . . . .	5-1	Meter Zero . . . . .	IIA-5
5-4. Periodic Maintenance . . . . .	5-1	IIA-26. Sensitivity Check . . . . .	IIA-5
5-6. Test Equipment . . . . .	5-1	IIA-27. Meter Accuracy Check . . . . .	IIA-5
5-8. Troubleshooting . . . . .	5-1	IIA-28. Low Pass Filter Check . . . . .	IIA-5
		IIA-29. In-Cabinet Performance	
		Check . . . . .	IIA-6

**LIST OF ILLUSTRATIONS**

Figure	Page	Figure	Page
1-1. Model 5253B . . . . .	1-0	5-4. Top View - Test Points . . . . .	5-9
3-1. Front Panel . . . . .	3-0	5-5. Schematic Diagram . . . . .	5-9
3-2. Frequency Measurement Procedure . . . . .	3-2		
3-3. Typical Frequency Measurements . . . . .	3-3	APPENDIX	
4-1. Block Diagram . . . . .	4-0	IA-1. Schematic Diagram . . . . .	IA-2
4-2. Harmonic Generator (A2, A3) . . . . .	4-0	IIA-1. Frequency Measurement Procedure . . . . .	IIA-2
4-3. Harmonic Selector Cavity . . . . .	4-1	IIA-2. Video Amplifier (A6) . . . . .	IIA-4
4-4. Balanced Mixer (A4) . . . . .	4-2	IIA-3. Level Indicator Meter Circuit . . . . .	IIA-4
4-5. Video Amplifier (A1) . . . . .	4-3	IIA-4. Top View . . . . .	IIA-6
4-6. Level Indicator Meter Circuit . . . . .	4-3	IIA-5. Left Side View . . . . .	IIA-7
5-1. A1 Video Amplifier Component Location . . . . .	5-6	IIA-6. Right Side View . . . . .	IIA-8
5-2. Left Side View . . . . .	5-7	IIA-7. Top View - Test Points . . . . .	IIA-9
5-3. Right Side View . . . . .	5-8	IIA-8. Schematic Diagram . . . . .	IIA-11

**LIST OF TABLES**

Table	Page	Table	Page
1-1. Specifications . . . . .	1-1	6-2. Replaceable Parts . . . . .	6-4
3-1. Frequency Resolution . . . . .	3-1	APPENDIX	
5-1. Recommended Test Equipment . . . . .	5-1	IA-1. Reference Designation Index . . . . .	IA-3
5-2. Resistance Troubleshooting Aid . . . . .	5-1	IIA-1. Specifications . . . . .	IIA-1
5-3. Troubleshooting Procedure . . . . .	5-2	IIA-2. Troubleshooting Procedure . . . . .	IIA-10
5-4. Adjustments after Repair . . . . .	5-4	IIA-3. Reference Designation Index . . . . .	IIA-12
6-1. Reference Designation Index . . . . .	6-2	IIA-4. Replaceable Parts . . . . .	IIA-14



Figure 1-1. Model 5253B and Accessory



## SECTION I

### GENERAL

#### 1-1. DESCRIPTION.

1-2. The Hewlett-Packard Model 5253B Frequency Converter is a plug-in unit which converts a Hewlett-Packard Model 5243L or 5245L Electronic Counter into a direct reading counter from 50 to 512 Mc.

1-3. The stability and accuracy of the basic counter are retained by multiplying a 10-Mc signal, derived from the 1-Mc internal time base of the counter, to a selectable harmonic frequency between 50 and 500 Mc. This known harmonic of 10 Mc is then heterodyned with the INPUT signal. If the resulting difference frequency is between 100 kc and 12 Mc (bandwidth of amplifier in plug-in), it is counted and displayed by the counter. The frequency of the INPUT signal is then indicated by the combination of the MIXING FREQUENCY control (in megacycles; front panel of plug-in) and the digital display of the counter (in megacycles).

1-4. A front panel meter, by monitoring the difference-frequency output of the plug-in to the counter, aids in selecting the desired MIXING FREQUENCY and also in determining if INPUT signal amplitude is adequate for accurate frequency measurement.

#### 1-5. SPECIFICATIONS.

1-6. Table 1-1 contains all technical specifications for the Model 5253B when operated in the Model 5243L

or Model 5245L Electronic Counter. Test specifications given in the Maintenance Section (Section V) of this manual, for the purposes of troubleshooting and adjustment, do not represent the technical specifications of the instrument.

#### 1-7. ACCESSORY.

1-8. A 50-ohm coaxial cable, 48 inches long, male BNC to male BNC, is furnished with the Model 5253B.

#### 1-9. INSTRUMENT IDENTIFICATION.

1-10. Hewlett-Packard identifies each Model 5253B with a two-section, eight-digit serial number. If the first three digits of the serial number of your instrument do not agree with those on the title page of this manual, change sheets supplied with the manual will define the differences between your instrument and the Model 5253B described in this manual.

#### 1-11. COOLING.

1-12. The Model 5253B is cooled by the ventilation system of the counter in which it is installed. See operating and service manual of counter for cooling system maintenance instructions.

Table 1-1. Specifications\*

<p><b>RANGE:</b> As converter for 5243L or 5245L counter, 50 Mc to 512 Mc, using mixing frequencies of 50 Mc to 500 Mc in 10 Mc steps.</p>
<p><b>ACCURACY:</b> Retains accuracy of 5243L or 5245L counter</p>
<p><b>INPUT VOLTAGE RANGE:</b> 50 mv to 1 v RMS</p>
<p><b>MAXIMUM INPUT:</b> 2 v RMS or 100 vdc will not damage the instrument</p>
<p><b>INPUT IMPEDANCE:</b> Approximately 50 ohms</p>
<p><b>LEVEL INDICATOR:</b> Meter aids frequency selection; indicates output voltage level to counter</p>
<p><b>REGISTRATION:</b> Counter display is added to the converter dial reading</p>
<p><b>WEIGHT:</b> Net 5-1/2 lbs, shipping 9 lbs</p>
<p><b>ACCESSORY FURNISHED:</b> Ⓟ10503A (AC-16K) Cable, 4 feet long, male BNC connectors</p>
<hr style="width: 50%; margin: 10px auto;"/> <p>*When installed in Hewlett-Packard Model 5243L or Model 5245L Electronic Counter.</p>

## SECTION II

### PREPARATION FOR USE

#### 2-1. UNPACKING AND INSPECTION.

2-2. If the shipping carton is damaged, ask that the carrier's agent be present when the instrument is unpacked. Inspect the instrument for damage (scratches, dents, broken knobs, etc). If the instrument is damaged or fails to meet specifications, notify the carrier and the nearest Hewlett-Packard field office immediately (field offices are listed at the back of this manual). Retain the shipping carton and the padding material for the carrier's inspection. The field office will arrange for the repair or replacement of your instrument without waiting for the claim against the carrier to be settled.

#### 2-3. ELECTRICAL INSPECTION.

2-4. The performance check procedure (Paragraph 5-31) may be used to verify proper electrical operation as part of an incoming quality control inspection.

#### 2-5. STORAGE AND RESHIPMENT.

2-6. **PACKAGING.** To protect valuable electronic equipment during storage or reshipment, always use the best packaging methods available. Your Hewlett-Packard field engineer can provide packing materials similar to those used for original factory packaging. Here are two recommended packing methods:

a. **Original.** Place instrument in original container. Replace each packing pad and filler in the exact position that it originally occupied.

b. **Alternate.** Cover panel with soft wrapping paper. Wrap corrugated cardboard completely around instrument and place in strong corrugated cardboard container (350 lb/sq in. bursting test). Insert filler material between wrapped instrument and container to obtain a snug fit on all surfaces. Filler should be rubberized hair (2 in. thick), excelsior (6 in. thick), or equivalent.

2-7. **ENVIRONMENT.** Conditions during storage and shipment should normally be limited as follows:

- a. Maximum altitude 20,000 feet (6,096 meters).

- b. Minimum temperature  $-40^{\circ}\text{F}$  ( $-40^{\circ}\text{C}$ ).

- c. Maximum temperature  $167^{\circ}\text{F}$  ( $75^{\circ}\text{C}$ ).

#### CAUTION

TURN COUNTER POWER OFF BEFORE  
INSTALLING OR REMOVING FREQUENCY  
CONVERTER.

#### 2-8. INSTALLATION.

2-9. The Model 5253B plugs into the rectangular compartment at the right-hand side of the front panel of the Model 5243L or 5245L Electronic Counter. To install unit in counter, first check that retaining screw (see Figure 3-1) is turned fully counterclockwise, then push unit firmly into compartment until front panel of plug-in is flush with front panel of counter. Then turn retaining screw clockwise until it is tight.

2-10. To remove unit from counter, turn retaining screw counterclockwise to its stop. Then grasp mixing frequency selector (see Figure 3-1) and firmly pull unit from counter. If any difficulty is encountered with installation or removal, check that retaining screw is fully counterclockwise.

#### 2-11. POWER REQUIREMENTS.

2-12. All electrical power required to operate the Model 5253B is supplied by the counter in which the unit is installed.

#### 2-13. ELECTRICAL CONNECTIONS.

2-14. **INPUT** connector on front panel of plug-in (see Figure 3-1) is the only external electrical connection to the unit. All other connections are made through the 50-pin connector at the rear of plug-in when installed in counter.

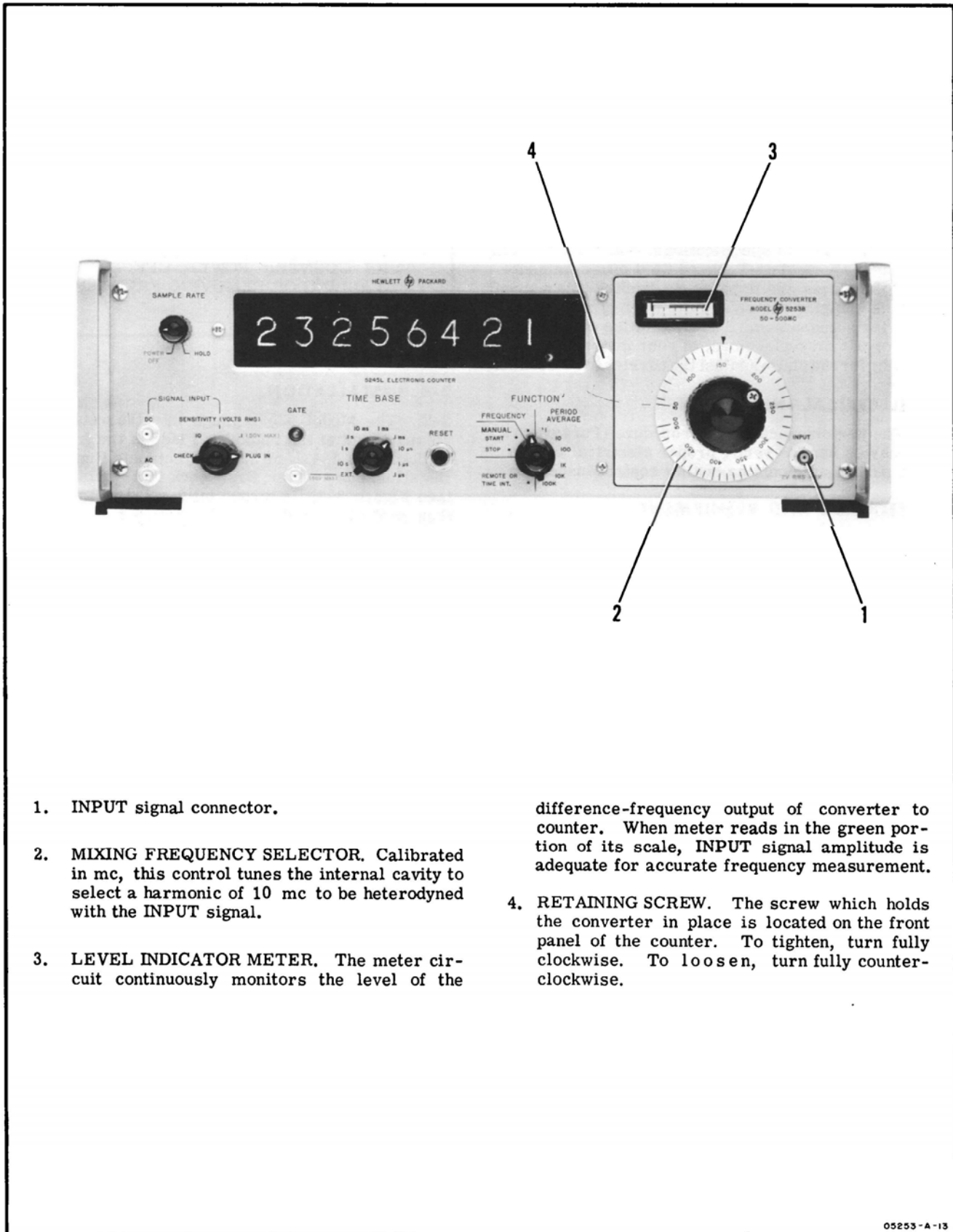

1. INPUT signal connector.
2. MIXING FREQUENCY SELECTOR. Calibrated in mc, this control tunes the internal cavity to select a harmonic of 10 mc to be heterodyned with the INPUT signal.
3. LEVEL INDICATOR METER. The meter circuit continuously monitors the level of the

- difference-frequency output of converter to counter. When meter reads in the green portion of its scale, INPUT signal amplitude is adequate for accurate frequency measurement.
4. RETAINING SCREW. The screw which holds the converter in place is located on the front panel of the counter. To tighten, turn fully clockwise. To loosen, turn fully counter-clockwise.

Figure 3-1. Front Panel

## SECTION III OPERATION

### 3-1. FRONT PANEL.

3-2. The functions of the front panel control, meter, connector, and retaining screws are given in Figure 3-1.

### 3-3. MAXIMUM INPUT VOLTAGES.

3-4. Damage to the converter may result if an AC signal greater than 2 v RMS or a DC voltage greater than 100 v is applied to converter INPUT connector.

### 3-5. OPERATING PROCEDURES.

#### 3-6. NORMAL RANGE MEASUREMENTS.

3-7. Figure 3-2 is the procedure to be used for measurement of frequencies from 100.1 to 512 Mc with INPUT signal amplitudes from 50 mv to 1 v RMS.

#### 3-8. EXTENDED RANGE MEASUREMENTS.

3-9. The frequency of signals not within the normal range of 100.1 to 512Mc, 50 mv to 1 v RMS, may be measured using the following procedures:

3-10. 88 TO 100.1 MC, 50 MV TO 1 V RMS. Perform steps 1 through 5 of Figure 3-2. Then:

- a. Set mixing frequency control to slightly more than 110 Mc.
- b. Turn mixing frequency control slowly clockwise until level indicator meter first reaches a maximum reading in the green portion of its scale.
- c. Subtract counter display (in Mc) from reading of mixing frequency control (in Mc) for frequency of INPUT signal.

3-11. 88 TO 512 MC, AMPLITUDE LESS THAN 50 MV RMS. The front panel level indicator meter indicates in the green portion of its scale only when converter is properly tuned and amplitude of INPUT signal is adequate for accurate frequency measurement. However, because of conservative specifications of both the converter and counter, frequencies may often be accurately measured when meter reads in the red portion of its scale. To make these extended range measurements:

- a. Follow normal procedure (Figure 3-2 or Paragraph 3-10, depending upon frequency range) except that mixing frequency control should be tuned for first maximum reading on the level indicator meter, regardless of the color of region maximum.
- b. Check frequency measurement result as described in Paragraph 3-12, or
- c. Insert an external variable attenuator (such as Hewlett-Packard Model 355A or 355C) in the transmission line between the converter and the source of INPUT signal. Vary attenuation from 0 to 1 db during final step of frequency measurement procedure. If counter display does not change more than momentarily (during switching of attenuator), INPUT signal is above noise threshold and frequency measurement result is valid.

### 3-12. DOUBLE-CHECKING FREQUENCY MEASUREMENT RESULT.

3-13. Because of the heterodyne action of the converter, frequency measurement results obtained at any one setting of the mixing frequency control may be checked at other settings. See Figure 3-3 for examples.

Table 3-1. Frequency Resolution

INPUT SIGNAL FREQUENCY = 151.1223344 Mc MIXING FREQUENCY CONTROL set to 140 Mc		
Time Base Setting	Counter Display	Measurement Resolution
.1 $\mu$ s	* (no display)	
1 $\mu$ s	1 1. Mc	1 5 1. Mc
10 $\mu$ s	1 1.1 Mc	1 5 1.1 Mc
.1 ms	1 1.1 2 Mc	1 5 1.1 2 Mc
1 ms	1 1 1 2 2. kc	1 5 1.1 2 2 Mc
10 ms	1 1 1 2 2.3 kc	1 5 1.1 2 2 3 Mc
.1 s	1 1 1 2 2.3 3 kc	1 5 1.1 2 2 3 3 Mc
1 s	1 1 1 2 2.3 3 4 kc	1 5 1.1 2 2 3 3 4 Mc
10 s	1 1 2 2.3 3 4 4 kc	1 5 1.1 2 2 3 3 4 4 Mc

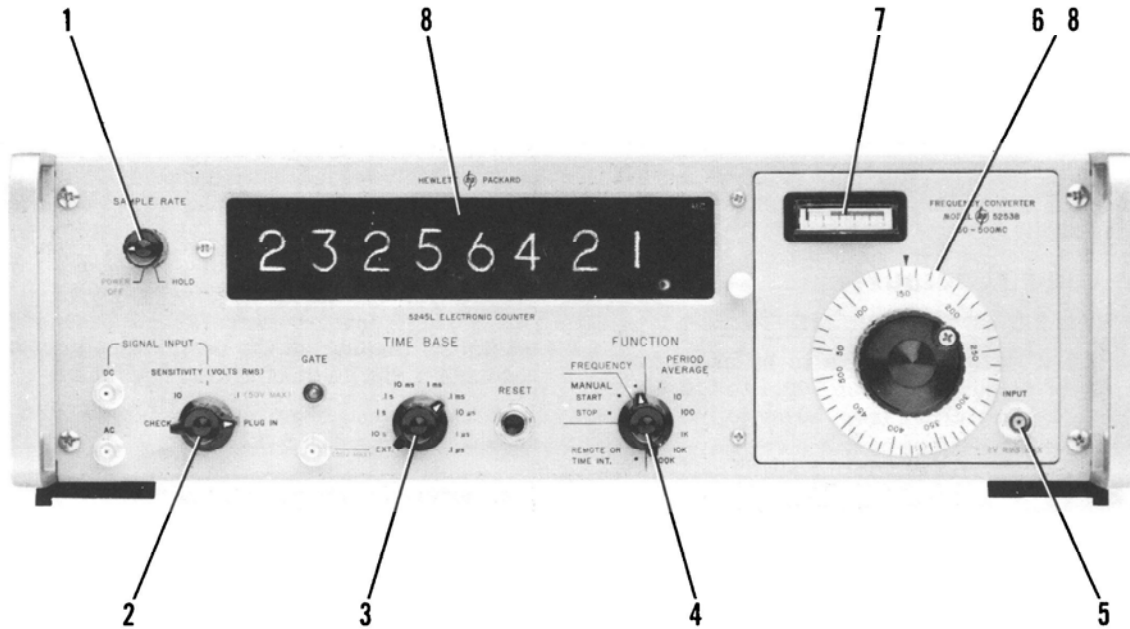

1. Turn SAMPLE RATE control slightly out of POWER OFF position.
2. Set SENSITIVITY to PLUG IN.
3. Set TIME BASE to .1 ms.\*
4. Set FUNCTION to FREQUENCY.
5. Connect signal whose frequency is to be measured to INPUT of converter.
6. Set mixing frequency control to read slightly less than 50 Mc.
7. Slowly turn mixing frequency control counterclockwise until level indicator meter first reaches a maximum reading in the green portion of its scale.
8. Add counter display (in Mc) to mixing frequency control reading (in Mc) for frequency of INPUT signal.

---

\* TIME BASE setting may vary, depending on desired resolution of INPUT signal frequency. See Table 3-1.

05253-A-14

Figure 3-2. Frequency Measurement Procedure

**3-14. AID TO RAPID TUNING**

3-15. To easily obtain an indication of the proper MIXING FREQUENCY when rapidly tuning the Model 5253B through its frequency range in search of an unknown INPUT frequency, set counter FUNCTION control to MANUAL START. This allows the counter to

totalize each cycle of any difference frequency produced during rapid tuning. When counter display changes, indicating that the MIXING FREQUENCY is heterodyning with the INPUT frequency and producing a difference frequency within the frequency range of the basic counter, set counter FUNCTION control to FREQUENCY and proceed with measurement.

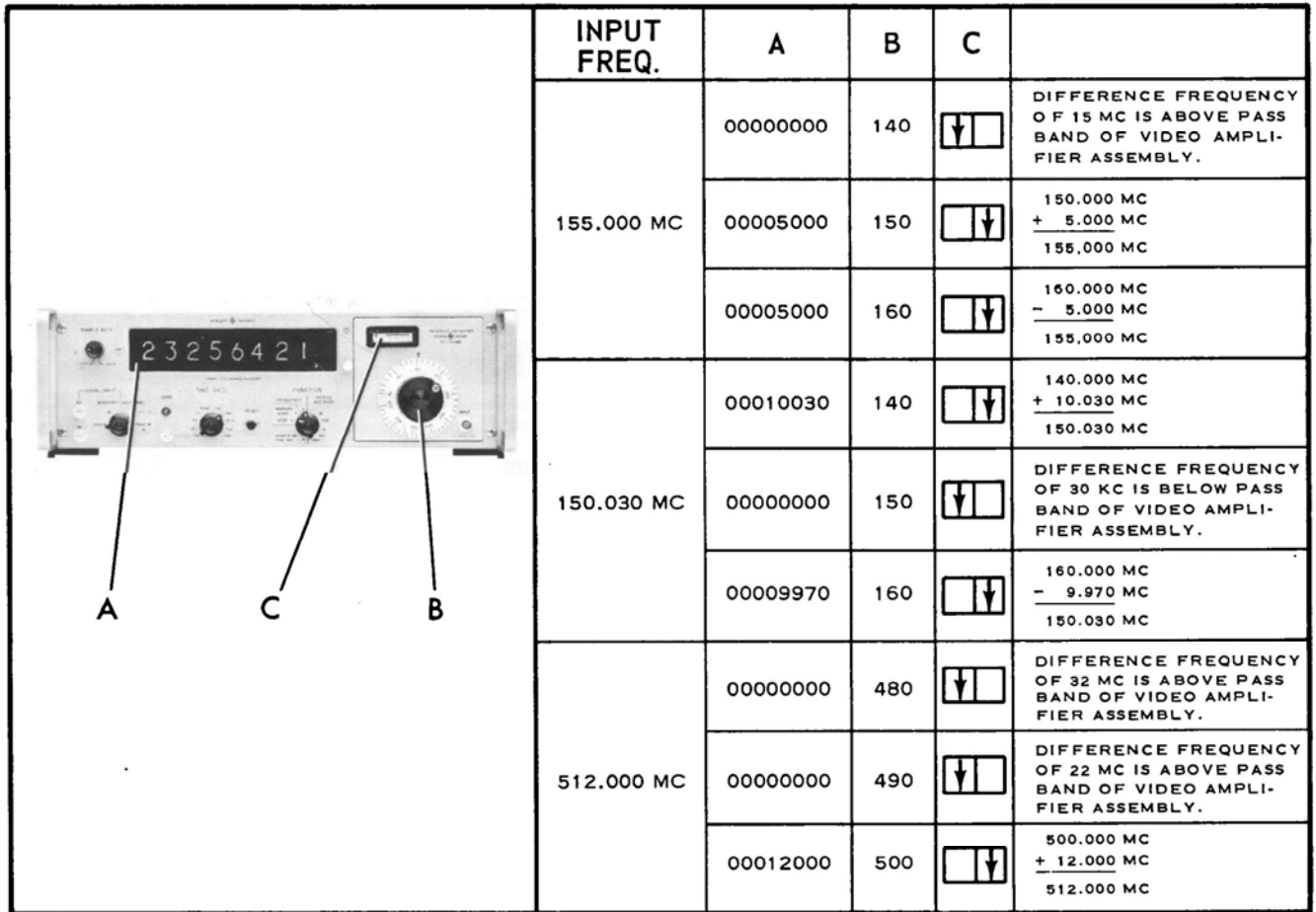

05253-A-11

Figure 3-3. Typical Frequency Measurements



## SECTION IV

### PRINCIPLES OF OPERATION

#### 4-1. GENERAL

4-2. The Model 5253B is a heterodyne frequency converter designed to extend the range of frequency measurement of the Model 5243L and 5245L Electronic Counters to 512 Mc.

4-3. The converter contains four basic functional sections: harmonic generator, harmonic selector cavity, mixer, and video amplifier (see Figure 4-1).

4-4. In normal operation, the harmonic generator produces all of the harmonics of 10 Mc between 50 and 500 Mc. The harmonic selector cavity is tuned to select one of these harmonics to be supplied to the mixer. The mixer output is the difference frequency produced by the mixing of the INPUT frequency and the frequency supplied by the harmonic selector cavity. This difference frequency is amplified by the video amplifier and supplied to the counter input circuit. A low-pass filter within the video amplifier prevents all difference frequency signals above approximately 12 Mc from reaching the counter input circuit. The output of the video amplifier is monitored by a meter circuit which indicates when difference frequency output amplitude is greater than minimum signal required by counter input circuit.

#### 4-5. HARMONIC GENERATOR (A2,A3), AND HARMONIC SELECTOR CAVITY

4-6. A 10-Mc signal, supplied by the Counter, is amplified by A3Q1 to cause a tuned circuit, composed of A3L2, A3C4, A3C5, A3C6, and C22, to oscillate at 10-Mc (Fig. 4-2). Step-recovery diode\*, A3CR1, takes energy from this tuned circuit during a portion of each cycle of the 10-Mc oscillation and produces a sharp step in the current following in the input loop of the harmonic selector cavity. This current step makes available, inside the cavity, all harmonics of 10 Mc from 10 Mc (fundamental) to over 500 Mc (fiftieth harmonic). The remaining components of the step-recovery diode network (Assembly A2) are used to maintain the sensitivity of the counter across its frequency range. The harmonic selector cavity is tuned to resonate at a particular harmonic of 10 Mc between 50 and 500 Mc so that energy at that frequency is coupled from the input loop to the output loops providing one of the two inputs to the mixer circuit (Fig. 4-22).

\*-hpa- Application Note #1 (The Step Recovery Diode; Circuit Design and Performance), -hpa- Application Note #2 (Harmonic Generation, Rectification, and Lifetime Evaluation with the Step Recovery Diode; reprinted from the PROCEEDINGS OF THE IRE, VOL. 50, NO. 7, JULY 1962); available from -hp associates-, 620 Page Mill Road, , Palo Alto, California.

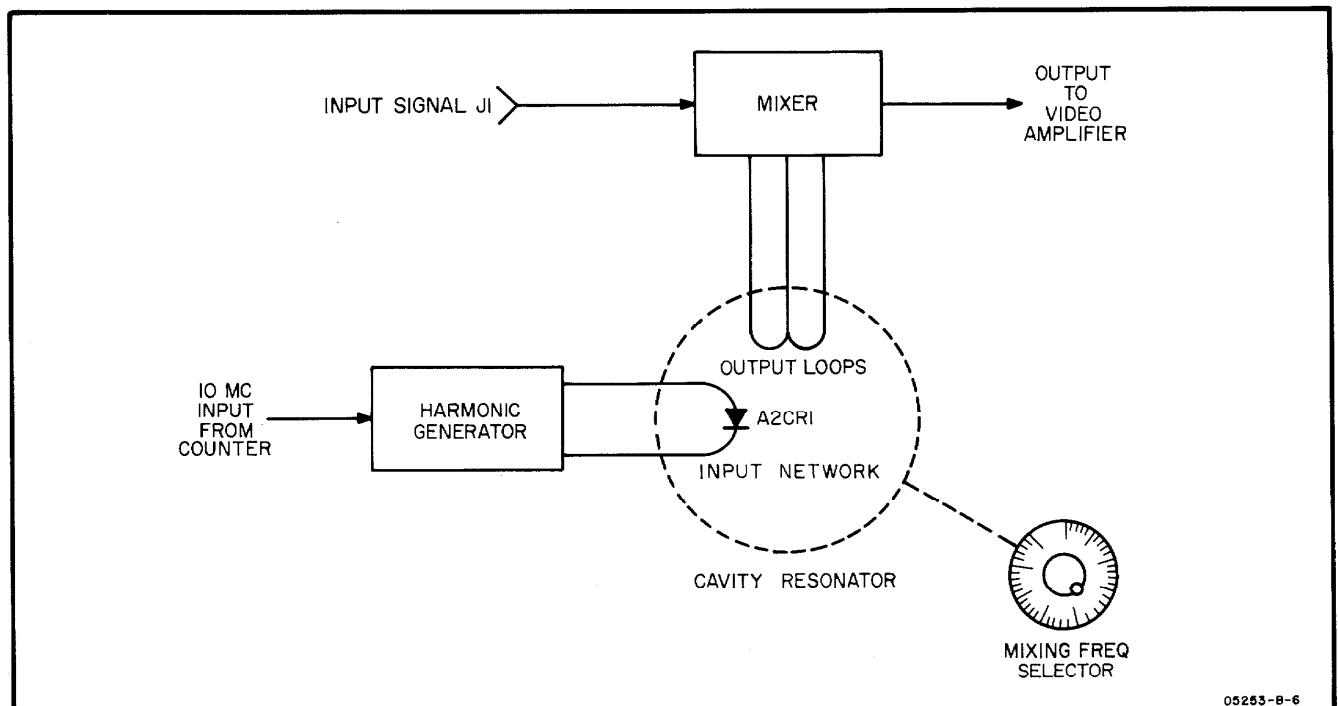

Figure 4-3. Harmonic Selector Cavity



**4-7. MIXER (A4)**

4-8. Matched diodes are used in a balanced mixer circuit in order to minimize the generation of even-order harmonics of both the INPUT signal and the selected mixing frequency. The balanced input signal required by the circuit is accomplished by grounding the junction of the two resistors of equal value, A4R1 and A4R2, and installing ferrite rings (E1, E2, and E3) around the input coaxial cable (see Figure 4-4). Both sides of resistor A4R1 are returned to common for DC currents. However, for AC currents in the frequency range of 50 to 512 Mc, the impedance of the input signal path is large, due to the inductance provided by the ferrite rings E1, E2, and E3, causing a balanced AC signal condition at the mixer diodes. Limiting diode A4CR2 prevents INPUT signals of high amplitude from overloading the mixer circuit. The output of the mixer diodes, during normal operation when the converter is properly tuned, is a complex signal containing the INPUT signal frequency, the frequency of the harmonic of 10 Mc to which the harmonic selector cavity is tuned, the frequency that is the sum of these two frequencies, and the frequency that is the difference between these two frequencies. Inductor A4L1 reduces the amplitude of any signal with a frequency above approximately 15 Mc before the signal reaches the input to the video amplifier. The output of the mixer circuit is then essentially composed of the difference frequency signal.

**4-9. VIDEO AMPLIFIER ASSEMBLY (A1)**

4-10. The output of the mixer circuit is amplified by transistors A1Q1 and A1Q2 and is fed to the 12-Mc low-pass filter network (see Figure 4-5). This filter passes any signal frequency below approximately 12 Mc and attenuates all higher frequency signals. The lowpass filter output is amplified by A1Q3 and A1Q4 and fed to the last transistor amplifier, A1Q5, which provides both the output to the counter and the drive for the level indicator meter. The limiter diode, A1CR1, prevents the amplitude of the video amplifier output signal from exceeding approximately 300 mv RMS so that counter input circuits will not be overloaded. The low frequency limit of the video amplifier, determined by the bypass and interstage coupling networks, is approximately 100 kc. The converter output signal to the counter, when converter is properly tuned, will be between approximately 100kc and 12 Mc and will have an amplitude that is less than approximately 300 mv RMS.

**4-11. LEVEL INDICATOR METER**

4-12. The DC current supply for the meter is produced by metering detector A1CR3 and smoothed by capacitor A1C16 (see Figure 4-6). The value of shunt resistor A1R20 is selected to make level indicator meter M1 read at red-green border when amplitude of converter output to counter is in excess of the 100-mv RMS minimum signal amplitude normally required by the counter for accurate frequency measurement.

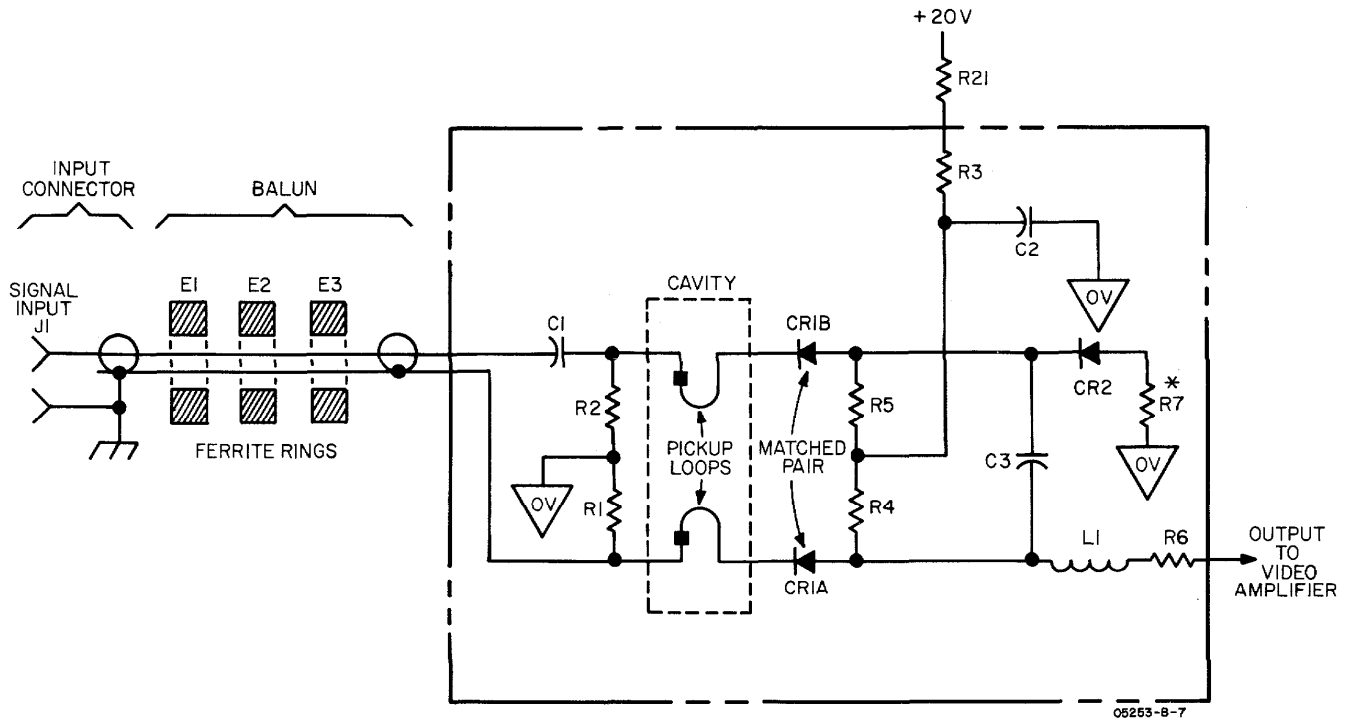

Figure 4-4. Balanced Mixer (A4)

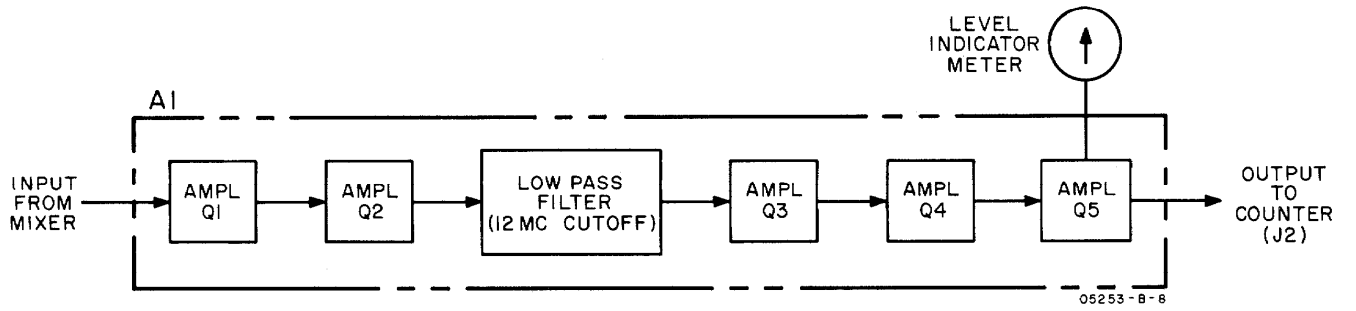

Figure 4-5. Video Amplifier (A1)

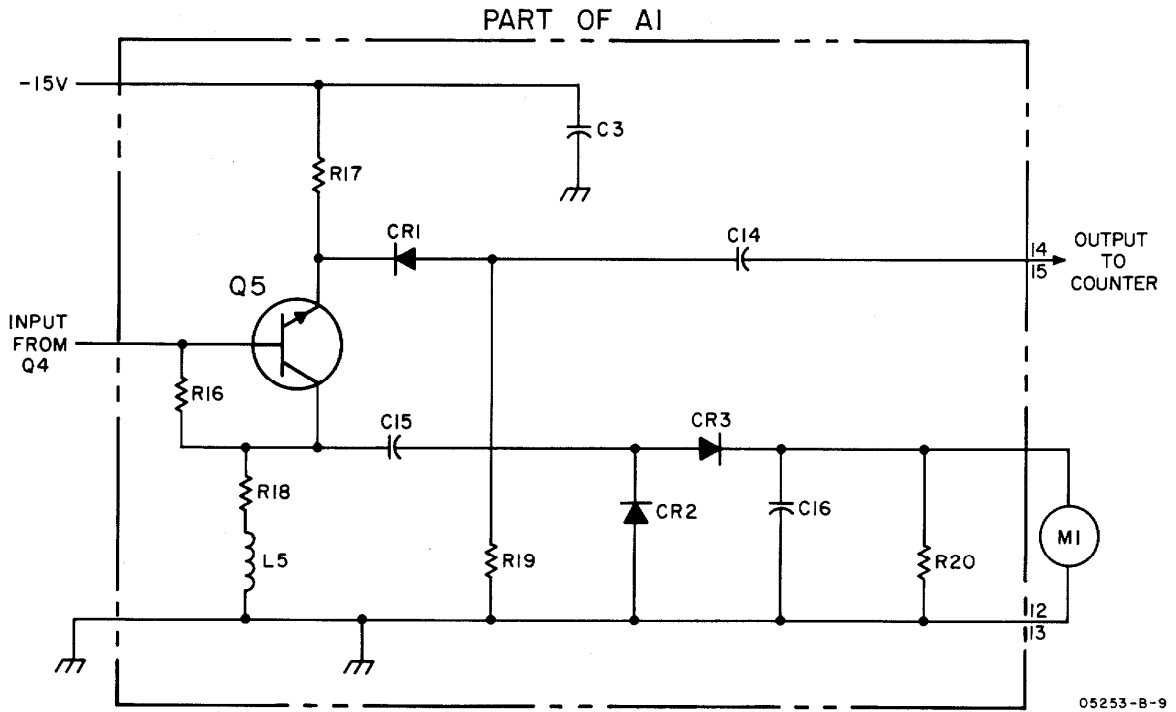

Figure 4-6. Level Indicator Meter Circuit

## SECTION V MAINTENANCE

### 5-1. GENERAL.

### 5-2. INTRODUCTION.

5-3. This section contains information concerning periodic maintenance, troubleshooting and recommended test equipment, repair, circuit adjustments, and performance testing. A complete schematic diagram of the converter is at the rear of this section (Figure 5-5).

### 5-4. PERIODIC MAINTENANCE.

5-5. No special maintenance procedures are required when the converter is operated in normal environments. However, if unit is subjected to operation in extremely dusty environments, periodically clean all gears with a lint-free cloth and apply a coating of light, petroleum base, open-gear grease to all gear teeth.

### 5-6. TEST EQUIPMENT.

5-7. All test instruments required for performance testing, troubleshooting, and circuit adjustment after repair are listed in Table 5-1. Instruments having equivalent specifications may be substituted for the specific instruments recommended.

### 5-8. TROUBLESHOOTING.

5-9. Table 5-2 lists resistances from connecting pins on connector J1 to chassis (when unit is not connected to counter) to aid in troubleshooting. Table 5-3 is a suggested troubleshooting procedure which lists circuit conditions at Test Points throughout the converter. These Test Points are keyed to the component

location drawings, Figures 5-1, 5-2, 5-3 and 5-4, and also to the schematic diagram, Figure 5-5. Voltages listed in Table 5-3 are approximate and may vary widely between instruments, due to variations in component values. Table 5-4 lists recommended adjustments to be made after repair of any section of the converter.

Table 5-2. Resistance Troubleshooting Aid

Location	Resistance (to Chassis)*
J1 - Pin 1	> 100 megohms
J1 - Pin 15	1 K ohms $\pm 20\%$
J1 - Pin 20	140 K ohms $\pm 20\%$
J1 - Pin 25	125 K ohms $\pm 20\%$

\*Unit not connected to counter.

### 5-10. REPAIR AND REPLACEMENT.

5-11. Paragraphs 5-12 through 5-19 are replacement procedures to aid in repair of the converter. Detailed procedures for replacement of all the individual components of the unit are beyond the scope of this manual. In-field repair is, for the most part, simple and straightforward. However, do not attempt adjustment of the gearing arrangement, the harmonic selector cavity or the step-recovery diode. Should gear, cavity, or step recovery diode problems arise, please contact your Hewlett-Packard field office to arrange for repair.

Table 5-1. Recommended Test Equipment

Instrument	Required Characteristics	Use	Instrument Recommended
Electronic Counter		Supply Power, Visual Operational Indicator	Ⓜ Model 5243L or Ⓜ Model 5245L
RF Millivoltmeter	1 Mc to 20 Mc 10 mv to 10 vdc 10 mv resolution	Circuit Adjustment, Troubleshooting	Ⓜ Model 411A with Pen Type Probe Tip, Ⓜ 11022A (formerly Ⓜ 411A-21B)
DC VTVM and Ohmmeter	0 to +25 vdc 0.1 v resolution 0 to 100 M ohms	Circuit Adjustment, Troubleshooting	Ⓜ Model 412A
VHF Signal Generator	50 Mc to 480 Mc 10 mv to 1 v	Circuit Adjustment, Troubleshooting	Ⓜ Model 608C
Oscilloscope	15 Mc bandwidth	Circuit Adjustment, Troubleshooting	Ⓜ Model 175A with Ⓜ Model 1752A High Gain Amplifier and Ⓜ Model 1780A Aux Unit
Extension Cable	50 pin straight-thru connections	Circuit Adjustment, Troubleshooting	Ⓜ 10506A (formerly Ⓜ AC-16Y)

Table 5-3. Troubleshooting Procedure

All voltages given are approximate and may vary from instrument to instrument because of variations in component characteristics.

TEST EQUIPMENT:  $\text{\textcircled{P}}$  Model 411A RF Millivoltmeter with  $\text{\textcircled{P}}$  11022A (formerly 411A-21B) Pen Type Probe Tip,  
 $\text{\textcircled{P}}$  Model 412A DC VTVM

REMOVE $\text{\textcircled{P}}$ 5253B FROM COUNTER; SELF-CHECK COUNTER	See counter manual for self-check procedure.
CONNECT $\text{\textcircled{P}}$ 5253B TO COUNTER WITH EXTENSION CABLE, $\text{\textcircled{P}}$ 10506A (formerly AC-16Y)	Extension cable available from $\text{\textcircled{P}}$ ; see parts list.
$\text{\textcircled{1}}$ +20 VDC $\text{\textcircled{2}}$ -15 VDC	Checks power supplied to plug-in from counter; see counter manual for power supply adjustment procedure.
$\text{\textcircled{3}}$ + 6 VDC 2 VAC	Checks 10-Mc drive of harmonic generator.
$\text{\textcircled{4}}$ + 2 VDC - 2 VAC	Checks generator diode drive. Voltages vary widely because of both the detuning effect of voltmeter probe and the variable value of A3R3. DC voltage may be either + or -, depending upon factory determined generator diode orientation.
$\text{\textcircled{5}}$ +100 MV DC $\text{\textcircled{6}}$ +100 MV DC	Voltages vary widely because of diode characteristics. Voltages are 0 VDC when diode shorted, and +20 VDC when diode open. Voltages should be approximately equal because of matched characteristics.

CONNECT SIGNAL GENERATOR TO  $\text{\textcircled{P}}$ 5253B.  
SET GENERATOR TO 52 MC, CW, 100 MV.  
SET COUNTER CONTROLS AND 5253B TO MEASURE FREQUENCY OF INPUT SIGNAL.

$\text{\textcircled{7}}$ 5 MV RMS	This voltage is total harmonic energy output of mixer and varies widely.
$\text{\textcircled{8}}$ -11.3 VDC 30 MV RMS	Checks bias and amplification of A1Q2 and A1Q1.
$\text{\textcircled{9}}$ -12.3 VDC 17 MV RMS	General check of low pass filter section
$\text{\textcircled{10}}$ -9.3 VDC 360 MV RMS	Checks bias and amplification of A1Q3 and A1Q4
$\text{\textcircled{11}}$ -7.1 VDC 300 MV RMS	Checks operation of A1Q5
$\text{\textcircled{12}}$ 0 VDC 190 MV RMS	Checks operation of limiter, A1CR1
$\text{\textcircled{13}}$ 0 MV DC WHEN METER READS AT LEFT END OF SCALE; 50 MV DC WHEN METER READS FULL SCALE; 15 MV DC WHEN TEST POINT #12 IS 100 MV RMS, AND METER READS AT RED-GREEN BORDER.	Checks accuracy of meter circuit in relation to output to counter

**5-12. PRINTED CIRCUIT COMPONENT REPLACEMENT.**

5-13. Component lead-holes in the  $\phi$  Model 5253B circuit boards have plated walls to insure good electrical contact between conductors on the opposite sides of the board. To prevent damage to this plating and also to the replacement component, apply heat sparingly and work carefully. The following replacement procedure is recommended:

a. Remove defective component.

b. Melt solder in component lead-holes. Use clean, "dry" soldering iron to remove excess solder. Clean holes with toothpick or wooden splinter. Do not use metal tool for cleaning as this may damage the through-hole plating.

c. Bend leads of replacement component to the correct shape and insert component leads in component lead-holes. Using heat and solder sparingly, solder leads in place. Heat may be applied to either side of board as is convenient. A heat sink (long-nose pliers, commercial heat-sink tweezers, etc.) should be used when replacing transistors and diodes in order to prevent excessive heat from being conducted by the leads from the soldering iron to the component.

d. Through-hole plating breaks are indicated by the separation from the board of the round conductor-pad on either side of the board. To repair breaks, press conductor-pads against board and solder replacement component lead to conductor-pad on both sides of the board.

**5-14. VIDEO AMPLIFIER ASSEMBLY REPLACEMENT.**

5-15. If video amplifier printed circuit board requires replacement, follow this procedure:

a. Remove the converter from counter.

b. Unscrew and remove small screw (MP1; see Figure 5-4) which holds video amplifier A1 in place. Remove screws which secure supporting bracket to front panel. Remove supporting bracket.

c. Firmly grasp assembly at component-free end and pull out of socket using a slight back-and-forth sideways movement.

d. Check that the connecting terminals of replacement assembly are clean. Push replacement assembly firmly into socket and check for proper seating. Replace supporting bracket and all screws.

e. All replacement video amplifier assemblies are adjusted and inspected at the factory for optimum performance. However, if a general operational check is desired, perform the in-cabinet performance check given in Paragraph 5-31.

**5-16. MIXER DIODE REPLACEMENT.**

5-17. If either of the matched pair of mixer diodes (A4CR1A or A4CR1B) is found to be defective, both

diodes should be replaced. The recommended replacement procedure is as follows:

a. Remove mixer-assembly shield cover (see Figure 5-3).

b. Remove diodes from spring clips, noting orientation.

c. Install replacement diodes with same orientation.

d. Replace mixer-assembly shield cover.

e. Perform the sensitivity check (Paragraph 5-28) to insure that converter operation is within specifications.

**5-18. METER REPLACEMENT PROCEDURE.**

5-19. If the level indicator meter requires replacement, follow this procedure:

a. Remove converter from counter.

b. Unscrew and remove small retaining screw (MP1; see Figure 5-4) which holds video amplifier board A1 in place. Remove screws which secure supporting bracket to front panel. Remove supporting bracket.

c. Firmly grasp video amplifier board at the component-free end and pull board out of socket using a slight back-and-forth sideways movement.

d. Place converter on bench with bottom plate resting on bench surface and with the front panel facing to the rear of the bench.

e. Remove screw (MP2) which holds aluminum spacer-rod (MP3) to plastic rear-support (MP4; see Figure 5-2). Grasp spacer-rod and turn counterclockwise to remove rod from front support.

f. Cut connecting wires at meter terminals.

g. Remove screws (MP5, 6; see Figure 5-4) from meter bezel at sides of meter. Push bezel forward as far as possible.

h. Remove screws (MP7, 8) on top of meter bracket.

i. Grasp meter and gently pull meter (and bracket) backwards out of front panel hole, at the same time twisting rear of meter slightly sideways to the right and pulling up.

j. Remove bracket and hardware from meter and install in identical manner on replacement meter. Hardware which may come from the manufacturer with the replacement meter may be discarded.

k. Place meter (with bracket) in unit by reversing removal procedure.

m. Replace screws on top of meter bracket.

n. Replace meter bezel at sides of meter.

p. Check that meter terminals are not close to front bearing-block. Bend terminals away from block if necessary.

q. Strip 1/4-inch insulation from ends of each connecting wire and solder to meter terminals. Black wire goes to inside terminal and white wire goes to outside terminal.

r. Replace aluminum spacer-rod. Tighten only "finger-tight" as excessive torque may break end of rod.

s. Replace screw which holds spacer-rod to rear-support.

t. Replace video amplifier assembly, supporting bracket, and all screws.

**5-20. HARMONIC GENERATOR ADJUSTMENT.**

5-21. To adjust the harmonic generator assembly, proceed as follows:

a. Remove converter from counter and reconnect to counter with Extension Cable, @10506A.

b. Connect VHF Signal Generator to converter INPUT and set to 472 Mc, CW, at 100 mv.

c. Connect RF Millivoltmeter to Test Point #12 (see Figure 5-4).

d. Set converter mixing frequency control to 470 Mc, and tune for maximum reading on RF Millivoltmeter.

e. Vary output of VHF Signal Generator to make converter level indicator meter read at red-green border.

f. Using plastic tuning tool, tune A3C5 (see Figure 5-2) for maximum reading on RF Millivoltmeter. Tune A3C5 through hole in harmonic generator assembly shield cover.

**5-22. LOW PASS FILTER ADJUSTMENT.**

5-23. To adjust the low pass filter in the video amplifier assembly, proceed as follows:

a. Remove converter from counter and reconnect to counter with Extension Cable, @10506A.

b. Connect VHF Signal Generator to converter INPUT and set to 110 Mc, CW, at 50 mv.

c. Connect RF Millivoltmeter to Test Point #12 (see Figures 5-4 and 5-5).

d. Set converter mixing frequency control to 100 Mc and tune for maximum reading on RF Millivoltmeter.

e. Set Signal Generator to 116.2 Mc, CW, at 1 v.

f. Using plastic tool, adjust variable inductor A1L4 (see Figures 5-1 and 5-5) for minimum reading of RF Millivoltmeter.

g. Set Signal Generator to 120.2 Mc, CW, at 1 v.

h. Using plastic tool, adjust variable inductor A1L3 (see Figures 5-1 and 5-5) for minimum reading of RF Millivoltmeter.

i. Set Signal Generator to 115 Mc, CW, at 1 v.

j. Reading of RF Millivoltmeter should be less than 100 mv. If reading is above 100 mv, troubleshoot video amplifier assembly.

Table 5-4. Adjustments after Repair

AFTER REPLACING COMPONENT IN THIS SECTION:	PERFORM:
Harmonic generator (A3)	Harmonic generator adjustment (Paragraph 5-20)
Mixer (A4)	Sensitivity check (Paragraph 5-28)
A1Q1	Sensitivity check (Paragraph 5-28)
A1Q2	Sensitivity check (Paragraph 5-28), and Low pass filter adjustment (Paragraph 5-22)
Low Pass Filter	Sensitivity check (Paragraph 5-28), and Low pass filter adjustment (Paragraph 5-22)
A1Q3	Sensitivity check (Paragraph 5-28), and Low pass filter adjustment (Paragraph 5-22)
A1Q4	Sensitivity check (Paragraph 5-28), and Low pass filter adjustment (Paragraph 5-22)
Meter circuit	Meter accuracy check (Paragraph 5-29)

**5-24. METER CALIBRATION ADJUSTMENT. (pri.)**

a. Turn counter power off, remove converter from counter, and reconnect to counter with Extension Cable,  $\text{Ⓢ}10506A$ .

b. Set VHF Signal Generator to 102 Mc, CW, at 50 mv and connect to INPUT of converter.

c. Set counter controls as shown in Figure 3-2. Counter should display approximately 2 Mc.

d. Vary VHF Generator output to make level indicator meter read at red-green border.

e. Using RF Millivoltmeter, measure voltage at Test Point #12. Voltage should be between 100 mv and 130 mv. If not, change value of resistor A1R19 to change voltage to between 100 mv and 130 mv. If voltage is too high, increase value of A1R19. If voltage is too low, decrease value of A1R19. Repeat steps d and e after changing value of A1R19.

**5-25. MECHANICAL ADJUSTMENT OF METER ZERO.**

5-26. TRUE SIGNAL LEVEL INDICATION. Level indicator meter is adjusted at the factory for proper mechanical zero. However, normal aging of meter components may change indicated zero level. To insure accuracy of input signal level indication, periodic adjustment of meter zero may be necessary.

5-27. ZERO-SET. When meter is properly zero-set, pointer rests over the zero calibration mark at the left-hand end of meter scale when converter is (1) at normal operating temperature, (2) in normal operating position, and (3) without power. Proceed as follows:

a. Allow counter and converter to operate for one hour to permit meter movement to reach normal operating temperature.

b. Turn counter off and allow one minute for all capacitors to discharge.

c. Remove converter from counter to enable access to rear of meter.

d. Remove adhesive-backed-paper cover from meter zero-adjustment access hole on top-rear of meter.

e. Carefully insert small tool in access hole and engage adjustment fork.

f. Vary setting of adjustment fork until meter reads zero.

g. Remove tool and replace adhesive-backed-paper cover on access hole. This completes meter zero adjustment procedure.

**5-28. SENSITIVITY CHECK.**

a. Turn counter power off, remove converter from counter, and reconnect to counter with Extension Cable,  $\text{Ⓢ}10506A$ .

b. Set VHF Signal Generator to 52 Mc, CW, at 50 mv and connect to INPUT of converter.

c. Adjust controls as shown in Figure 3-2.

d. Set converter mixing frequency control to 50 Mc. Counter should display approximately 2 Mc.

e. Using RF Millivoltmeter, measure output of converter at Test Point #12 (see Figures 5-4 and 5-5). Voltage should be at least 100 mv.

f. Repeat above steps c, d, and e with VHF Generator frequency of 472 Mc and converter mixing frequency control set to 470 Mc. Converter output to counter, as measured by RF Millivoltmeter, should be at least 100 mv.

g. A similar check may be made at any frequency within the range of the Model 5253B. Converter output to counter should be at least 100 mv when difference frequency is between 100 kc and 12 Mc and converter is properly tuned.

**5-29. METER ACCURACY CHECK.**

a. Turn counter power off, remove converter from counter, and reconnect to counter with Extension Cable,  $\text{Ⓢ}10506A$ .

b. Set VHF Signal Generator to 102 Mc, CW, at 50 mv and connect to INPUT of converter.

c. Set controls as shown in Figure 3-2. Set converter mixing frequency control to 100 Mc. Counter should display approximately 2 Mc.

d. Vary output of VHF Signal Generator for converter level indicator to make meter read at red-green border.

e. Using RF Millivoltmeter, measure converter output to counter at Test Point #12. Voltage should be between 100 mv and 130 mv. If not, see Paragraph 5-24 for meter calibration adjustment procedure.

**5-30. LOW PASS FILTER CHECK.**

a. Turn counter power off, remove converter from counter and reconnect to counter with Extension Cable,  $\text{Ⓢ}10506A$ .

b. Set VHF Signal Generator to 110 Mc, CW, at 50 mv and connect to INPUT of converter.

c. Set controls as shown in Figure 3-2. Set converter mixing frequency control to 100 Mc. Counter should display approximately 10 Mc.

d. Connect RF Millivoltmeter to Test Point #12. Vary output of VHF Signal Generator for RF Millivoltmeter reading of 100 mv. Note output level of VHF Signal Generator.

e. Set VHF Signal Generator to 115 Mc at same output level as noted in step d above. Converter output to counter, as shown on RF Millivoltmeter, should not exceed 50 mv. If converter output to counter is greater than 50 mv, see Paragraph 5-23 for low pass filter adjustment procedure.

**5-31. IN-CABINET PERFORMANCE CHECK.**

a. Turn counter power off and install converter.

b. Set VHF Signal Generator to 52 Mc, CW, at 50 mv and connect to INPUT of converter.

c. Set controls as shown in Figure 3-2. Counter should display approximately 2 Mc.

d. Set VHF Signal Generator to any frequency between 50 Mc and 512 Mc with output of 50 mv. Counter should display correct frequency at any frequency within this range.

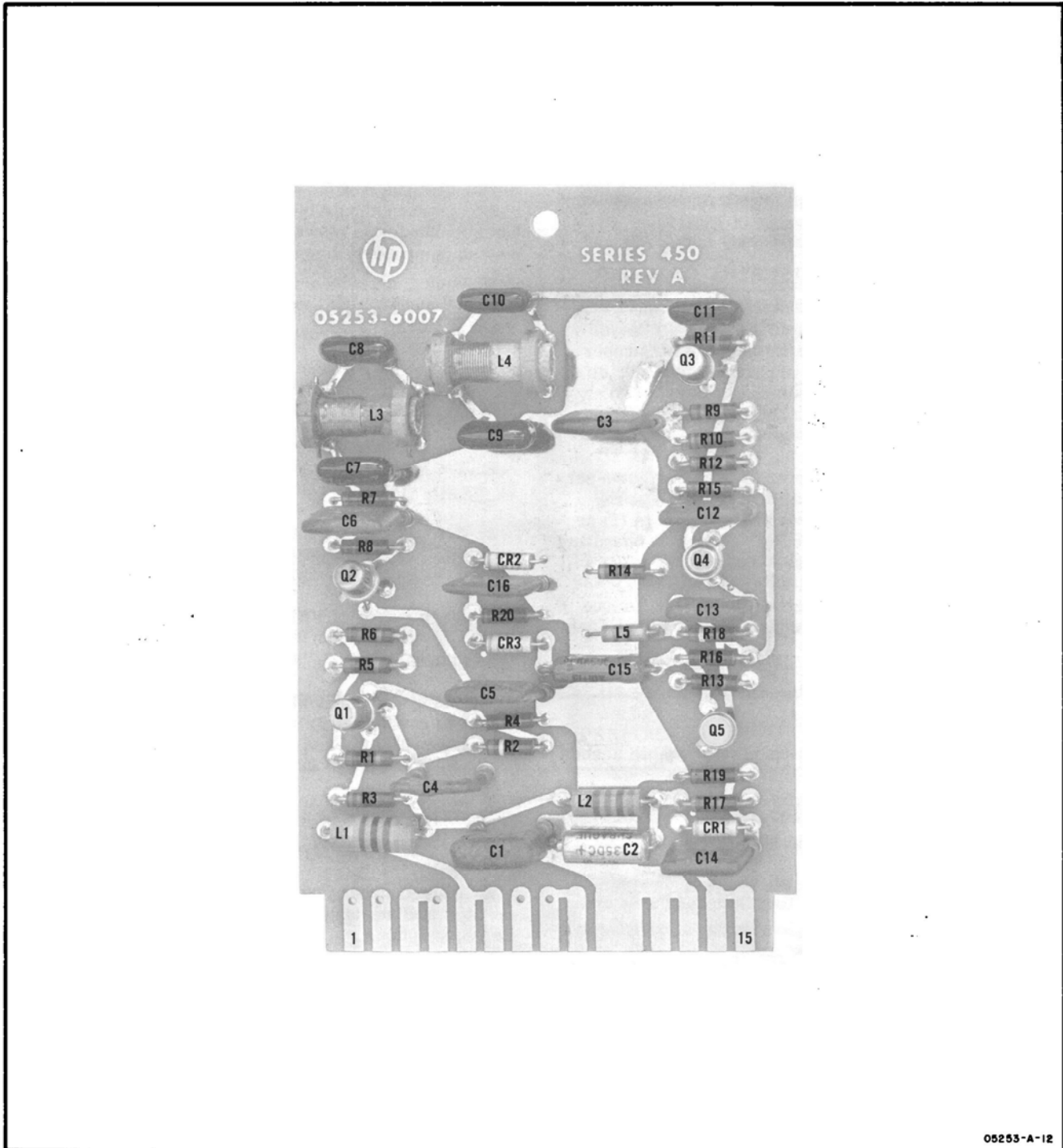

Figure 5-1. Video Amplifier Assembly A1 Component Location



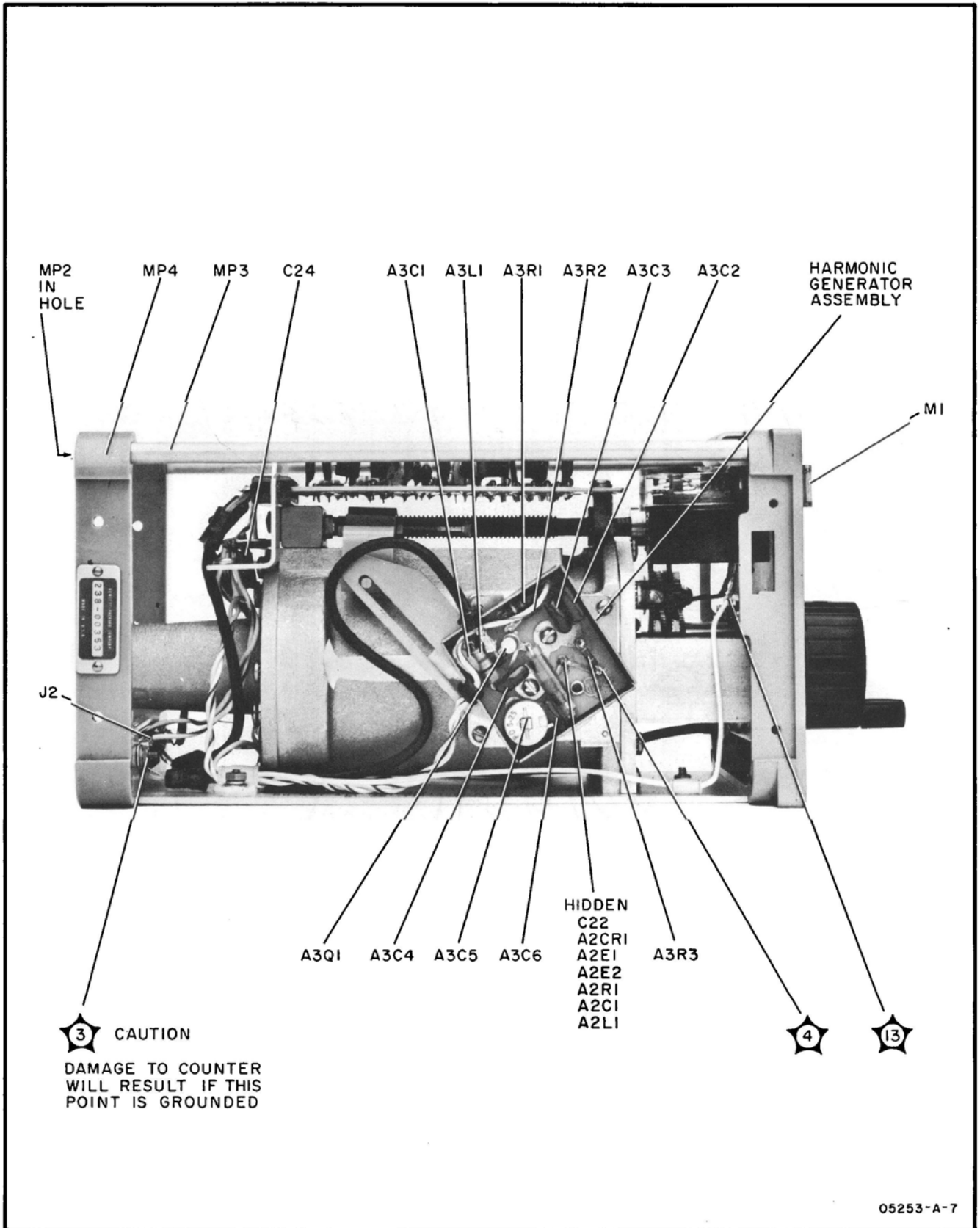

Figure 5-2. Left Side View

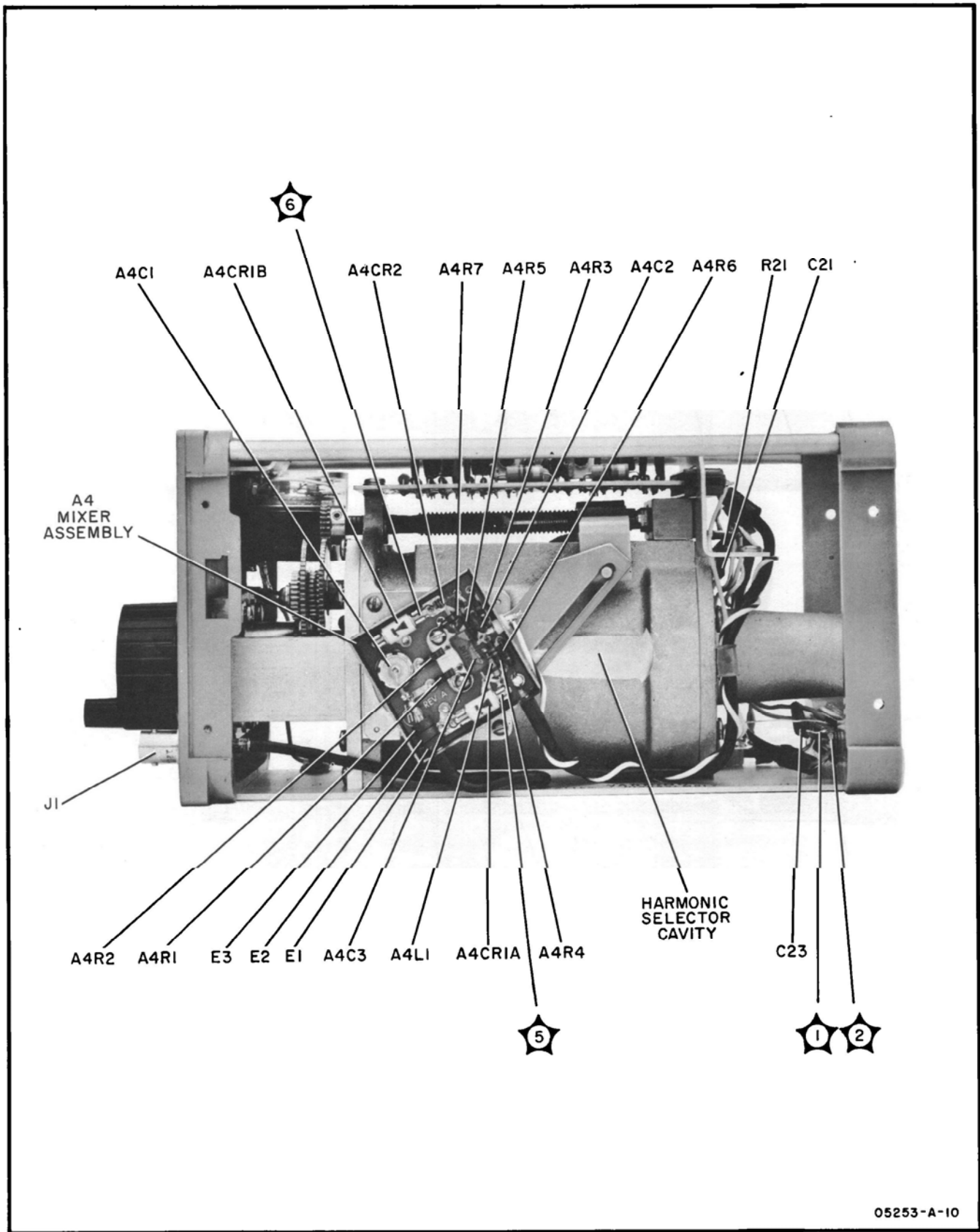

Figure 5-3. Right Side View

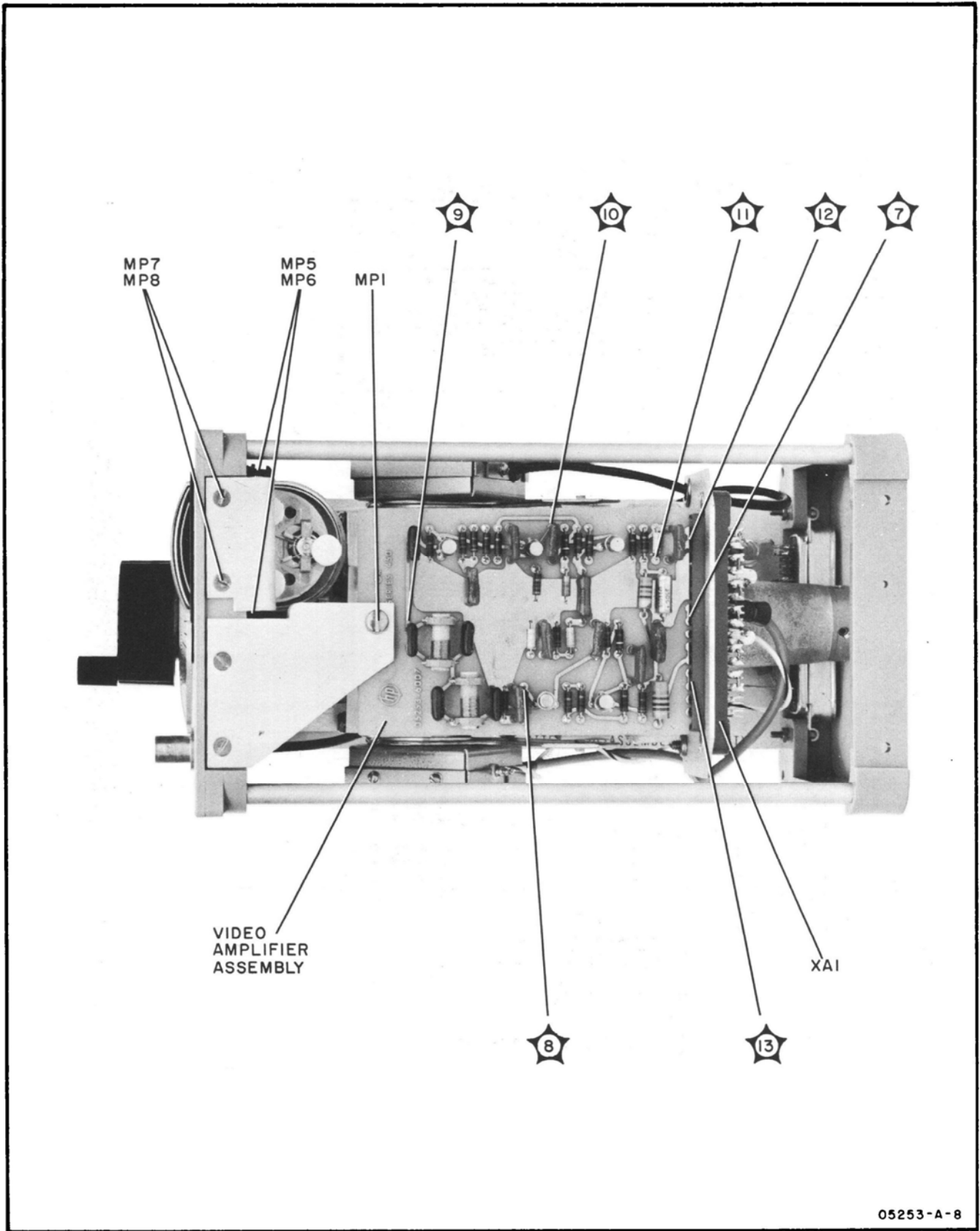
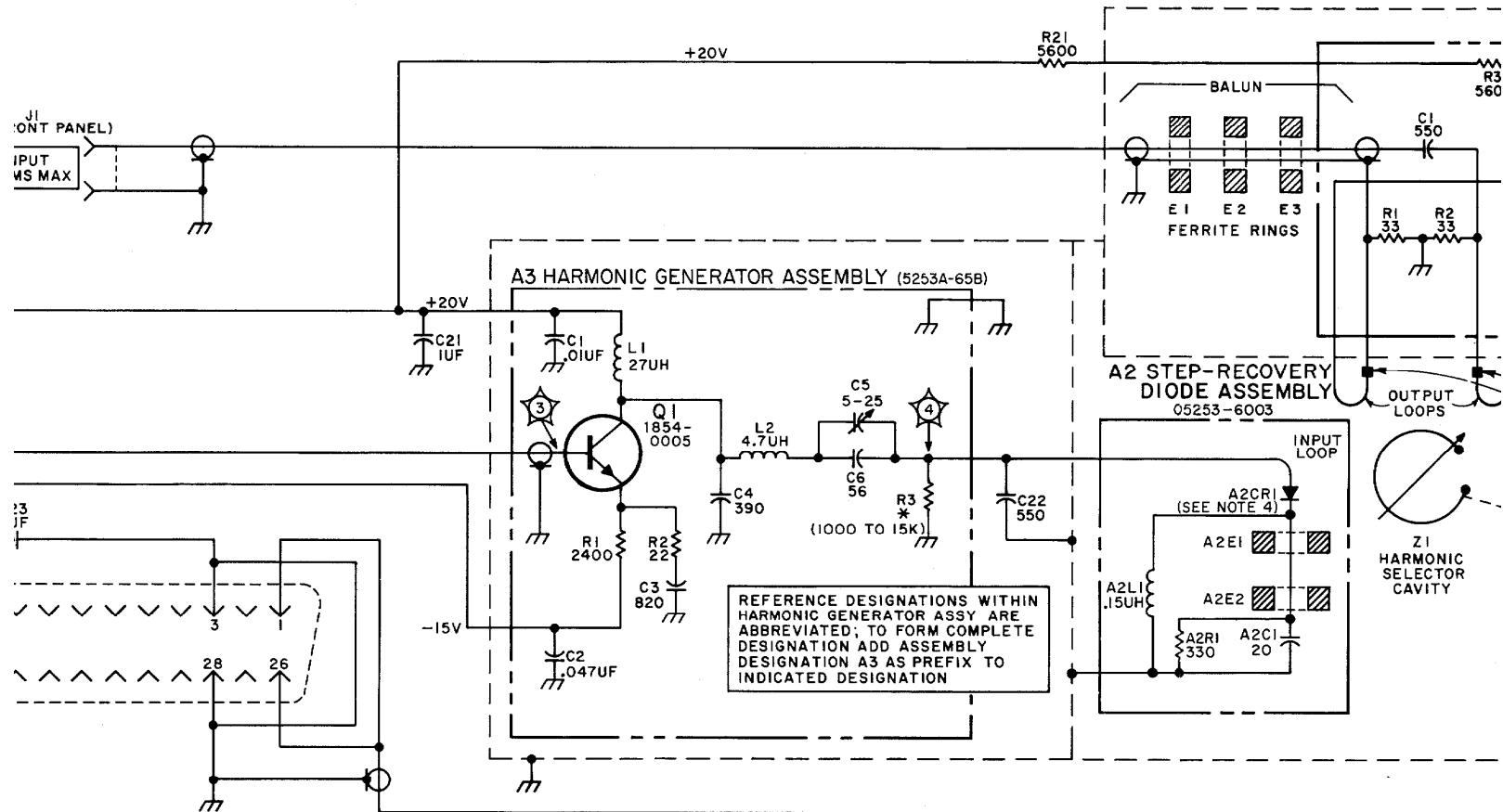
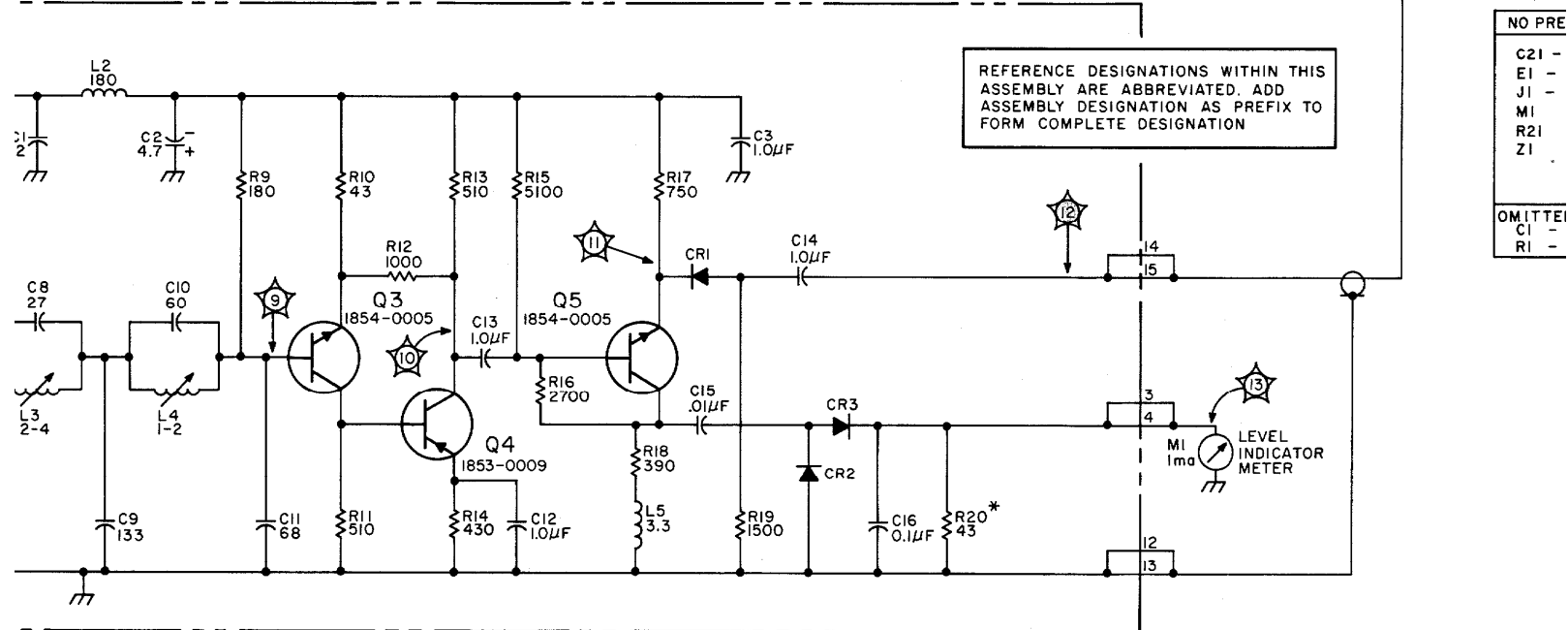

Figure 5-4. Top View - Test Points





**DEO AMPLIFIER ASSEMBLY (05253-6007)**



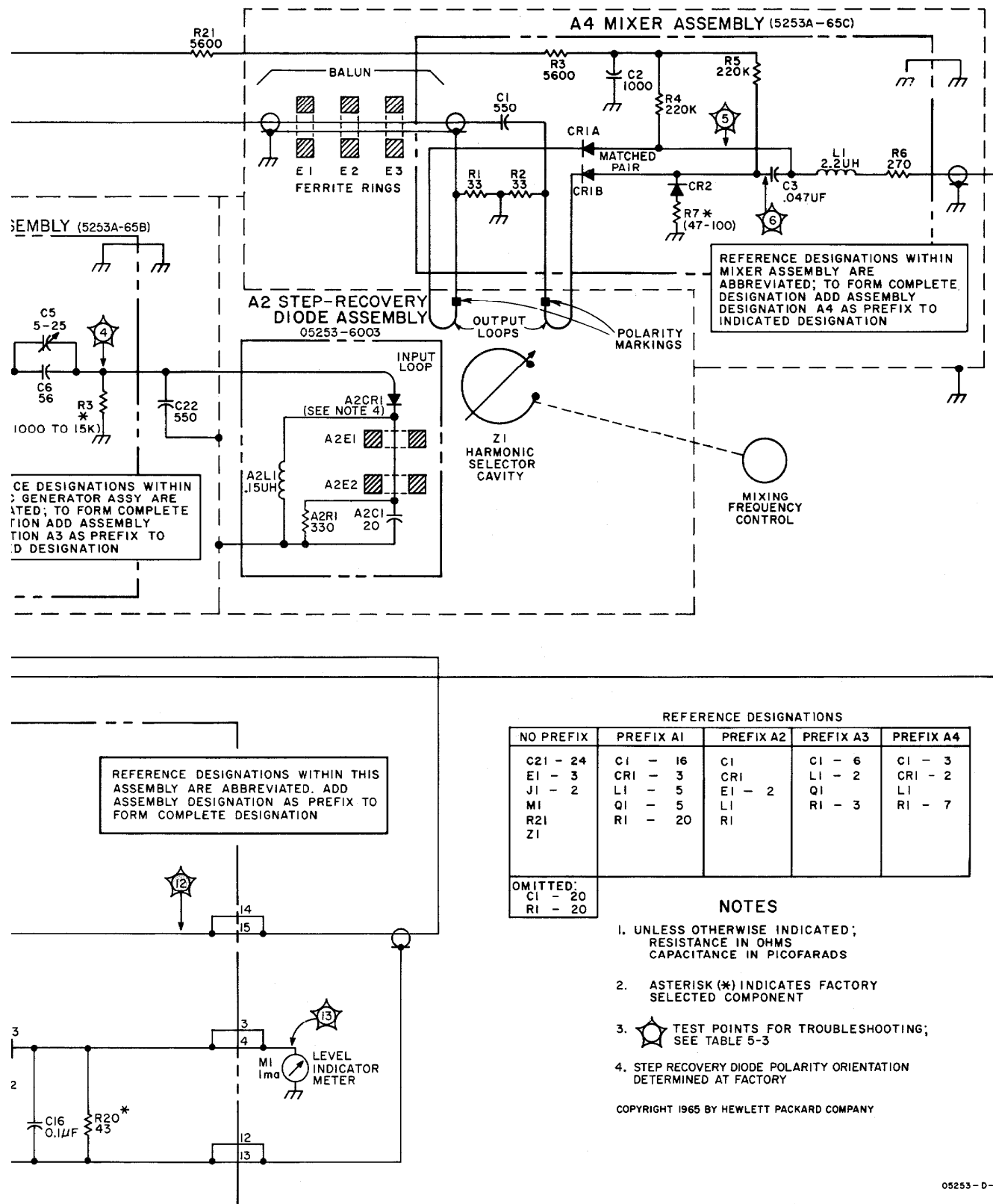

REFERENCE DESIGNATIONS

NO PREFIX	PREFIX A1	PREFIX A2	PREFIX A3	PREFIX A4
C21 - 24	C1 - 16	C1	C1 - 6	C1 - 3
E1 - 3	CR1 - 3	CR1	L1 - 2	CR1 - 2
J1 - 2	L1 - 5	E1 - 2	Q1	L1
M1	Q1 - 5	L1	R1 - 3	R1 - 7
R21	R1 - 20	R1		
Z1				

OMITTED:  
C1 - 20  
R1 - 20

NOTES

- UNLESS OTHERWISE INDICATED;  
RESISTANCE IN OHMS  
CAPACITANCE IN PICOFARADS
- ASTERISK (\*) INDICATES FACTORY  
SELECTED COMPONENT
- ☆ TEST POINTS FOR TROUBLESHOOTING;  
SEE TABLE 5-3
- STEP RECOVERY DIODE POLARITY ORIENTATION  
DETERMINED AT FACTORY

COPYRIGHT 1965 BY HEWLETT PACKARD COMPANY

05253-D-1A

Figure 5-5. Schematic Diagram

5-9/5-10

## SECTION VI REPLACEABLE PARTS

### 6-1. INTRODUCTION.

6-2. This section contains information for ordering replacement parts. Table 6-1 lists parts in alpha-numerical order of their reference designators and indicates the description and  $\Phi$  stock number of each part, together with any applicable notes. Table 6-2 lists parts in alpha-numerical order of their  $\Phi$  stock number and provides the following information on each part:

- a. Description of the part (see list of abbreviations below).
- b. Typical manufacturer of the part in a five-digit code; see list of manufacturers in Table 6-3.
- c. Manufacturer's part number.
- d. Total quantity used in the instrument (TQ column).

6-3. Miscellaneous parts are listed at the end of Table 6-1.

### 6-4. ORDERING INFORMATION.

6-5. To obtain replacement parts, address order or inquiry to your local Hewlett-Packard Field Office (see lists at rear of this manual for addresses). Identify parts by their Hewlett-Packard stock numbers.

6-6. To obtain a part that is not listed, include:

- a. Instrument model number.
- b. Instrument serial number.
- c. Description of the part.
- d. Function and location of the part.

#### REFERENCE DESIGNATORS

A = assembly	E = misc electronic part	MP = mechanical part	TB = terminal board
B = motor	F = fuse	P = plug	TP = test point
C = capacitor	FL = filter	Q = transistor	V = vacuum tube, neon bulb, photocell, etc.
CP = coupling	J = jack	R = resistor	W = cable
CR = diode	K = relay	RT = thermistor	X = socket
DL = delay line	L = inductor	S = switch	Y = crystal
DS = device signaling (lamp)	M = meter	T = transformer	

#### ABBREVIATIONS

A = amperes	GE = germanium	N/C = normally closed	RMO = rack mount only
A.F.C = automatic frequency control	GL = glass	NE = neon	RMS = root-mean-square
AMPL = amplifier	GRD = ground(ed)	NI PL = nickel plate	S-B = slow-blow
B. F. O. = beat frequency oscillator	H = henries	N/O = normally open	SCR = screw
BE CU = beryllium copper	HEX = hexagonal	NPO = negative positive zero (zero temperature coefficient)	SE = selenium
BH = binder head	HG = mercury	NRFR = not recommended for field replacement	SECT = section(s)
BP = bandpass	HR = hour(s)	NSR = not separately replaceable	SEMICON = semiconductor
BRS = brass	IF = intermediate freq	OBD = order by description	SI = silicon
BWO = backward wave oscillator	IMPG = impregnated	OH = oval head	SIL = silver
CCW = counter-clockwise	INCD = incandescent	OX = oxide	SL = slide
CER = ceramic	INCL = include(s)	P = peak	SPL = special
CMO = cabinet mount only	INS = insulation(ed)	PC = printed circuit	SST = stainless steel
COEF = coefficient	INT = internal	PF = picofarads = 10 <sup>-12</sup> farads	SR = split ring
COM = common	K = kilo = 1000	PH BRZ = phosphor bronze	STL = steel
COMP = composition	LIN = linear taper	PHL = Phillips	TA = tantalum
CONN = connector	LK WASH = lock washer	PIV = peak inverse voltage	TD = time delay
CP = cadmium plate	LOG = logarithmic taper	P/O = part of	TGL = toggle
CRT = cathode-ray tube	LPF = low pass filter	POLY = polystyrene	TI = titanium
CW = clockwise	M = milli = 10 <sup>-3</sup>	PORC = porcelain	TOL = tolerance
DEPC = deposited carbon	MEG = meg = 10 <sup>6</sup>	POT = potentiometer	TRIM = trimmer
DR = drive	METFLM = metal film	PP = peak-to-peak	TWT = traveling wave tube
ELECT = electrolytic	MFR = manufacturer	PT = point	U = micro = 10 <sup>-6</sup>
ENCAP = encapsulated	MINAT = miniature	RECT = rectifier	VAR = variable
EXT = external	MOM = momentary	RF = radio frequency	VDCW = dc working volts
F = farads	MTG = mounting	RH = round head	W/ = with
FH = flat head	MY = "mylar"		W = watts
FIL H = fillister head	N = nano (10 <sup>-9</sup> )		WW = wirewound
FXD = fixed			W/O = without

01194-10

01874-3

Table 6-1. Reference Designation Index

Reference Designation	Stock No.	Description #	Note
A1	05253-6007 05253-2007	ASSY:AMPLIFIER BOARD:BLANK P.C.	
A1C1	0160-0128	C:FXD CER 2.2UF 20% 25VDCW	
A1C2	0180-0100	C:FXD ELECT TA 4.7UF 10% 35VDCW	
A1C3	0160-0127	C:FXD CER 1UF 20% 25VDCW	
A1C4	0160-0137	C:FXD CER 0.33UF 20% 25VDCW	
A1C5	0160-0127	C:FXD CER 1UF 20% 25VDCW	
A1C6	0160-0127	C:FXD CER 1UF 20% 25VDCW	
A1C7	0140-0194	C:FXD MICA 110 PF 5% 300 VDCW	
A1C8	0160-0178	C:FXD MICA 27PF 5% 300VDCW	
A1C9	0160-0332	C:FXD MICA 133PF 1%	
A1C10	0140-0214	C:FXD MICA 60PF 5% 300VDCW	
A1C11	0140-0192	C:FXD MICA 68PF 5% 300VDCW	
A1C12	0160-0127	C:FXD CER 1UF 20% 25VDCW	
A1C13	0160-0127	C:FXD CER 1UF 20% 25VDCW	
A1C14	0160-0127	C:FXD CER 1UF 20% 25VDCW	
A1C15	0160-0161	C:FXD MY 0.01 UF 10% 200VDCW	
A1C16	0150-0121	C:FXD CER 0.1UF +80%-20% 50VDCW	
A1CR1	1910-0022	SEMICON DEVICE:DIODE GE 100MA 6PIV 3.5NS	
A1CR2	1910-0022	SEMICON DEVICE:DIODE GE 100MA 6PIV 3.5NS	
A1CR3	1910-0022	SEMICON DEVICE:DIODE GE 100MA 6PIV 3.5NS	
A1L1	9140-0137	COIL:FXD RF 1000UH	
A1L2	9140-0138	COIL:FXD RF 180UH 5%	
A1L3	9140-0126	COIL:VAR 1.76-4.02	
A1L4	9140-0125	COIL:VAR 0.9-1.9 UH	
A1L5	9140-0143	COIL:FXD RF 3.3 UH	
A1Q1	1854-0005	TRANSISTOR:2N708 NPN SILICON	
A1Q2	1853-0009	TRANSISTOR:SILICON PNP	
A1Q3	1854-0005	TRANSISTOR:2N708 NPN SILICON	
A1Q4	1853-0009	TRANSISTOR:SILICON PNP	
A1Q5	1854-0005	TRANSISTOR:2N708 NPN SILICON	
A1R1	0683-1025	R:FXD COMP 1000 OHM 5% 1/4W	
A1R2	0683-3925	R:FXD COMP 3900 OHM 5% 1/4W	
A1R3	0683-4305	R:FXD COMP 43 OHM 5% .25W	
A1R4	0683-5115	R:FXD COMP 510 OHM 5% 1/4W	
A1R5	0683-1025	R:FXD COMP 1000 OHM 5% 1/4W	
A1R6	0683-5115	R:FXD COMP 510 OHM 5% 1/4W	
A1R7	0683-4315	R:FXD COMP 430 OHM 5% 1/4W	
A1R8	0683-1315	R:FXD COMP 130 OHM 5% 1/4W	
A1R9	0683-1815	R:FXD COMP 180 OHM 5% 1/4W	
A1R10	0683-4305	R:FXD COMP 43 OHM 5% .25W	
A1R11	0683-5115	R:FXD COMP 510 OHM 5% 1/4W	
A1R12	0683-1025	R:FXD COMP 1000 OHM 5% 1/4W	
A1R13	0683-5115	R:FXD COMP 510 OHM 5% 1/4W	
A1R14	0683-4315	R:FXD COMP 430 OHM 5% 1/4W	
A1R15	0683-5125	R:FXD COMP 5100 OHM 5% 1/4W	
A1R16	0683-2725	R:FXD COMP 2700 OHM 5% 1/4W	
A1R17	0683-7515	R:FXD COMP 750 OHM 5% 1/4W	

# See list of abbreviations in introduction to this section



Table 6-1. Reference Designation Index (Cont'd)

Reference Designation	Ⓢ Stock No.	Description #	Note
A1R18 A1R19 A1R20	0683-3915 0683-1525 0683-4305	R:FXD COMP 390 OHM 5% 1/4W R:FXD COMP 1500 OHM 5% 1/4W R:FXD COMP 43 OHM 5% .25W FACTORY SELECTED PART:TYPICAL VALUE GIVEN	
A2	05253-6003	ASSY:STEP RECOVERY DIODE	
A2C1 A2CR1	0150-0061	C:FXD CER 20 PF 100 VDCW SPECIALLY SELECTED PART NOT RECOMMENDED FOR FIELD REPLACEMENT	
A2E1 A2E2	9170-0029 9170-0029	CORE: FERRITE BEAD CORE: FERRITE BEAD	
A2L1	9140-0170	COIL:FXD .15 UH 20% 350 MA	
A2R1	0683-3315	R:FXD COMP 330 OHM 5% 1/4W FACTORY SELECTED PART:TYPICAL VALUE GIVEN	
A3	5253A-65B	ASSY:HARMONIC GENERATOR	
A3C1 A3C2 A3C3 A3C4 A3C5	0150-0093 0170-0094 0140-0151 0140-0200 0130-0016	C:FXD CER 0.01UF +80-20% 100VDCW C:FXD MY 0.047UF 20% 50VDCW C:FXD MICA 820PF 2% 300VDCW C:FXD MICA 390PF 5% 300VDCW C:VAR CER 5-25 PF NPO	
A3C6	0140-0191	C:FXD MICA 56 PF 5% 300 VDCW	
A3L1 A3L2	9140-0107 9140-0025	COIL:FXD RF 27 UH COIL:FXD RF 4.7 UHY	
A3Q1 A3R1 A3R2 A3R3	1854-0005 0686-2425 0683-2205 0683-5625	TRANSISTOR:SILICON NPN 2N708 R:FXD COMP 2400 OHM 5% 1/2W R:FXD COMP 22 OHM 5% 1/4W R:FXD COMP 5600 OHM 5% 1/4W FACTORY SELECTED PART:TYPICAL VALUE GIVEN	
A4	5253A-65C	ASSY:MIXER	
A4C1 A4C2 A4C3	0140-0069 0150-0050 0170-0040	C:FXD MICA 550 PF 10% 500 VDCW C:FXD CER 1000PF 600 VDCW C:FXD MY .047 UF 10% 200VDCW	
A4CR1 A4CR2	1900-0011 1910-0016	SEMICON DEVICE:DIODE 1N4168M MATCH PAIR DIODE:GERMANIUM:100MA ATO.85V 60PIV	
A4L1	9140-0142	COIL:FXD RF 2.2 UH	
A4R1 A4R2 A4R3 A4R4 A4R5	0683-3305 0683-3305 0684-5621 0683-2245 0683-2245	R:FXD COMP 33 OHM 5% 1/4W R:FXD COMP 33 OHM 5% 1/4W R:FXD COMP 5.6K OHM 10% 1/4W R:FXD COMP 220K OHM 5% 1/4W R:FXD COMP 220K OHM 5% 1/4W	
A4R6 A4R7	0683-2715 0683-6205	R:FXD COMP 270 OHM 5% 1/4W R:FXD COMP 62 OHM 5% 1/4W FACTORY SELECTED PART:TYPICAL VALUE GIVEN	
C21 C22	0160-0127 0140-0069	C:FXD CER 1UF 20% 25VDCW C:FXD MICA 550 PF 10% 500 VDCW NOT RECOMMENDED FOR FIELD REPLACEMENT	

# See list of abbreviations in introduction to this section

Table 6-1. Reference Designation Index (Cont'd)

Reference Designation	Stock No.	Description #	Note
C23	0160-0127	C:FXD CER 1UF 20% 25VDCW	
C24	0160-0127	C:FXD CER 1UF 20% 25VDCW	
E1	9170-0059	MAGNETIC CORE:TOROID FERRITE	
E2	9170-0059	MAGNETIC CORE:TOROID FERRITE	
E3	9170-0059	MAGNETIC CORE:TOROID FERRITE	
J1	1250-0102	CONNECTOR:1BNC	
J2	1251-0099	CONNECTOR:50 PIN MINAT	
M1	1120-0140	METER:0-1 MILLIAMPERE EDGE-VIEW	
R21	0684-5621	R:FXD COMP 5.6K OHM 10% 1/4W	
XA1	1251-0135	CONNECTOR:PRINTED CIRCUIT 15 CONTACTS	
		MISCELLANEOUS	
	05251-0002	BRACKET:METER	
	05253-0006	BRACKET:PANEL	
	05253-2014	PANEL:FRONT	
	05253-0005	PLATE:BOTTOM	

# See list of abbreviations in introduction to this section

Table 6-2 Replaceable Parts

Stock No.	Description #	Mfr.	Mfr. Part No.	TQ
0130-0016	C:VAR CER 5-25 PF NPO	28480	0130-0016	1
0140-0069	C:FXD MICA 550 PF 10% 500 VDCW	00853	TYPE M 100 E10	2
0140-0151	C:FXD MICA 820PF 2% 300VDCW	04062	RDM15F821G35	1
0140-0176	C:FXD MICA 100 PF 2% 300 VDCW	04062	DM15F101G 300V	1
0140-0189	C:FXD MICA 5825 PF 2% 300 VDCW	04062	DM20F5825G	1
0140-0191	C:FXD MICA 56 PF 5% 300 VDCW	04062	RDM15E560J3C	2
0140-0192	C:FXD MICA 68PF 5% 300VDCW	04062	RDM15E680J3C	1
0140-0193	C:FXD MICA 82 PF 5% 300 VDCW	04062	DM15E820J 300V	1
0140-0194	C:FXD MICA 110 PF 5% 300 VDCW	04062	RDM15F111J3C	1
0140-0200	C:FXD MICA 390PF 5% 300VDCW	04062	RDM15F391J3C	1
0140-0203	C:FXD MICA 30PF 5% 500VDCW	04062	DM15E300J 500V	1
0140-0204	C:FXD 47PF 5% NPO 500 VDCW	04062	DM15E470J	1
0140-0214	C:FXD MICA 60PF 5% 300VDCW	04062	RDM15E600J3C	1
0150-0050	C:FXD CER 1000PF 600 VDCW	84411	TYPE E	1
0150-0061	C:FXD CER 20 PF 100 VDCW	56289	53C47	1
0150-0093	C:FXD CER 0.01UF +80-20% 100VDCW	91418	TA	1
0150-0121	C:FXD CER 0.1UF +80%-20% 50VDCW	56289	5C50A	3
0160-0127	C:FXD CER 1UF 20% 25VDCW	56289	5C13	14
0160-0128	C:FXD CER 2.2UF 20% 25VDCW	56289	5C15	1
0160-0137	C:FXD CER 0.33UF 20% 25VDCW	56289	5C10	3
0160-0161	C:FXD MY 0.01 UF 10% 200VDCW	28480	Q160-0161	1
0160-0178	C:FXD MICA 27PF 5% 300VDCW	04062	RDM15E270J35	1
0160-0332	C:FXD MICA 133PF 1%	28480	0160-0332	1
0170-0040	C:FXD MY .047 UF 10% 200VDCW	28480	Q170-0040	1
0170-0094	C:FXD MY 0.047UF 20% 50VDCW	84411	TYPE 602	1
0180-0100	C:FXD ELECT TA 4.7UF 10% 35VDCW	56289	150D475X9035B2	2
0683-1025	R:FXD COMP 1000 OHM 5% 1/4W	01121	CB 1025	5
0683-1225	R:FXD 1200 OHM 5% 1/4W	01121	EB1225	4
0683-1315	R:FXD COMP 130 OHM 5% 1/4W	01121	CB 1315	1
0683-1525	R:FXD COMP 1500 OHM 5% 1/4W	01121	CB 1525	1
0683-1815	R:FXD COMP 180 OHM 5% 1/4W	01121	CB 1815	1
0683-2205	R:FXD COMP 22 OHM 5% 1/4W	01121	CB 2205	1
0683-2225	R:FXD 2.2K OHM 5% 1/4W	01121	CB2225	1
0683-2245	R:FXD COMP 220K OHM 5% 1/4W	01121	CB 2245	2
0683-2715	R:FXD COMP 270 OHM 5% 1/4W	01121	CB 2715	1
0683-2725	R:FXD COMP 2700 OHM 5% 1/4W	01121	CB-2725	1
0683-3305	R:FXD COMP 33 OHM 5% 1/4W	01121	CB 3305	3
0683-3315	R:FXD COMP 330 OHM 5% 1/4W	01121	CB 3315	1
0683-3615	R:FXD COMP 360 OHMS 5% 1/4W	01121	CB 3615	1
0683-3915	R:FXD COMP 390 OHM 5% 1/4W	01121	CB 3915	2
0683-3925	R:FXD COMP 3900 OHM 5% 1/4W	01121	CB 3925	1
0683-4305	R:FXD COMP 43 OHM 5% .25W	01121	CB 4305	3
0683-4315	R:FXD COMP 430 OHM 5% 1/4W	01121	CB 4315	2
0683-4725	R:FXD COMP 4700 OHMS 5% 1/4W	01121	CB 4725	2
0683-5115	R:FXD COMP 510 OHM 5% 1/4W	01121	CB 5115	5
0683-5125	R:FXD COMP 5100 OHM 5% 1/4W	01121	CB 5125	1
0683-5625	R:FXD COMP 5600 OHM 5% 1/4W	01121	CB 5625	1
0683-6205	R:FXD COMP 62 OHM 5% 1/4W	01121	CB 6205	1
0683-6815	R:FXD COMP 680 OHMS 5% 1/4W	01121	CB 6815	1
0683-7515	R:FXD COMP 750 OHM 5% 1/4W	01121	CB 7515	1

# See list of abbreviations in introduction to this section

Table 6-2. Replaceable Parts (Cont'd)

Stock No.	Description #	Mfr.	Mfr. Part No.	TQ
0683-7525	R:FXD COMP 7500 OHMS 5% 1/4W	01121	CB 7525	1
0683-8205	R:FXD COMP 82 OHMS 5% 1/4W	01121	CB 8205	1
0684-1041	R:FXD 100 K OHM 10% 1/4 W	01121	CB 1041	1
0684-1511	R:FXD COMP 15K OHMS 10% 1/4W	01121	CB 1231	1
0684-2701	R:FXD 27 OHM 10% 1/4 W	01121	CB 2701	1
0684-5621	R:FXD COMP 5.6K OHM 10% 1/4W	01121	CB 5621	2
0686-2425	R:FXD COMP 2400 OHM 5% 1/2W	01121	EB 2425	1
1120-0140	METER:0-1 MILLIAMPERE EDGE-VIEW	28480	1120-0140	1
1250-0102	CONNECTOR:BNB	91737	7011	1
1251-0099	CONNECTOR:50 PIN MINAT	28480	1251-0099	1
1251-0135	CONNECTOR:PRINTED CIRCUIT 15 CONTACTS	95354	SD-615UR	1
1850-0091	TRANSISTOR:GERMANIUM 2N2048 PNP	87216	2N2048	4
1853-0009	TRANSISTOR:SILICON PNP	28480	1853-0009	2
1854-0005	TRANSISTOR:2N708 NPN SILICON	07263	2N708	4
1900-0011	SEMICON DEVICE:DIODE 1N4168M MATCH PAIR	93332	1N4168M	1
1901-0040	DIODE:SILICON	28480	1901-0040	3
1910-0016	DIODE:GERMANIUM:100MA ATO.85V 60PIV	28480	1910-0016	1
1910-0022	SEMICON DEVICE:DIODE GE 100MA 6PIV 3.5NS	28480	1910-0022	3
9140-0025	COIL:FXD RF 4.7 UHY	28480	9140-0025	1
9140-0107	COIL:FXD RF 27 UH	99800	1840-38	1
9140-0111	COIL:FXD RF 3.3UHY	28480	9140 0111	1
9140-0118	COIL:FXD 500 UH 5%	99800	2500-14	2
9140-0125	COIL:VAR 0.9-1.9 UH	28480	9140-0125	2
9140-0126	COIL:VAR 1.76-4.02	28480	9140-0126	2
9140-0137	COIL:FXD RF 1000UH	28480	9140-0137	1
9140-0138	COIL:FXD RF 180UH 5%	99800	9140-0138	1
9140-0142	COIL:FXD RF 2.2 UH	28480	9140-0142	1
9140-0143	COIL:FXD RF 3.3 UH	28480	9140-0143	1
9140-0170	COIL-FXD .15 UH 20% 350 MA	78526	11503M	1
9170-0029	CORE: FERRITE BEAD	02114	56-590-65/4A	2
9170-0059	MAGNETIC CORE:TOROID FERRITE	02114	396T125-3D3	3
05253-2007	BOARD:BLANK P.C. AMPLIFIER	28480	05253-2007	1
05253-6003	ASSY:STEP RECOVERY DIODE	28480	05253-6003	1
05253-6007	ASSY:AMPLIFIER	28480	05253-6007	1
5253A-65B	ASSY:HARMONIC GENERATOR	28480	5253A-65B	1
5253A-65C	ASSY:MIXER	28480	5253A-65C	1
05251-0002	BRACKET:METER	28480	05251-0002	1
05253-0005	PLATE:BOTTOM	28480	05253-0005	1
05253-0006	BRACKET:PANEL	28480	05253-0006	1
05253-2014	PANEL:FRONT	28480	05253-2014	1

# See list of abbreviations in introduction to this section

Table 6-3. Manufacturer's Code

The following code numbers are from the Federal Supply Code for Manufacturers Cataloging Handbooks H4-1 (Name to Code) and H4-2 (Code to Name) and their latest supplements. The date of revision and the date of the supplements used appear at the bottom of each page. Alphabetical codes have been arbitrarily assigned to suppliers not appearing in the H4 handbooks.

Table with 4 columns: Code No., Manufacturer, Address, Code No., Manufacturer, Address. It lists various electronic component manufacturers such as U.S. A. Common, McCoy Electronics, Sage Electronics Corp., Humidail Co., Westrex Corp., Garlock Packing Co., Electronic Products Div., Aerovox Corp., Amp, Inc., Aircraft Radio Corp., Northern Engineering Laboratories, Inc., Sangamo Electric Company, etc.

Galley 3 - Hewlett Packard Code List

00015-39  
Revised: February, 1965

From: FSC. Handbook Supplements  
H4-1 Dated DECEMBER 1964  
H4-2 Dated MARCH 1962

Table 6-3. Manufacturer's Code (cont'd)

Code No.	Manufacturer	Address	Code No.	Manufacturer	Address	Code No.	Manufacturer	Address	Code No.	Manufacturer	Address
81349	Military Specification	.....	85474	R.M. Bracamonte & Co.	San Francisco, Calif.	93829	G. V. Controls	Livingston, N. J.	98220	Francis L. Mosley	Pasadena, Calif.
81415	Wilkor Products, Inc.	Cleveland, Ohio	85660	Koiled Kords, Inc.	New Haven, Conn.	93983	Insuline-Van Norman Ind., Inc.	Manchester, N.H.	98276	Microdot, Inc.	Pasadena, Calif.
81453	Raytheon Mfg. Co., Industrial Components Div., Industr. Tube Operations	Newton, Mass.	85911	Seamless Rubber Co.	Chicago, Ill.	94137	Electronic Division	Bayonne, N. J.	98291	Sealectro Corp.	Mamaroneck, N. Y.
81483	International Rectifier Corp.	El Segundo, Calif.	86197	Clifton Precision Products	Clifton Heights, Pa.	94144	General Cable Corp.	Dayton, Ohio	98405	Carad Corp.	Redwood City, Calif.
81541	The Airpax Products Co.	Cambridge, Mass.	86579	Precision Rubber Products Corp.	Dayton, Ohio	94145	Raytheon Mfg. Co., Industrial Components Div., Receiving Tube Operation	Quincy, Mass.	98731	General Mills	Minneapolis, Minn.
81860	Barry Controls, Inc.	Watertown, Mass.	86684	Radio Corp. of America, RCA	Harrison, N. J.	94148	Raytheon Mfg. Co., Semiconductor Div., California Street Plant	Newton, Mass.	98821	North Hills Electric Co.	Mineola, N. Y.
82042	Carler Parts Co.	Skokie, Ill.	87216	Phlco Corporation (Lansdale Division)	Lansdale, Pa.	94154	Scientific Radio Products, Inc.	Loveland, Colo.	98925	Clevite Transistor Prod. Div. of Clevite Corp.	Waltham, Mass.
82142	Jeffer's Electronics Division of Speer Carbon Co.	Du Bois, Pa.	87473	Western Fibrous Glass Products Co.	San Francisco, Calif.	94197	Tung-Sol Electric, Inc.	Newark, N. J.	98978	International Electronic Research Corp.	Burbank, Calif.
82170	Allen B. DuMont Labs, Inc.	Clifton, N. J.	87654	Van Waters & Rogers Inc.	Seattle, Wash.	94222	Curtiss-Wright Corp., Electronics Div.	East Paterson, N. J.	99109	Columbia Technical Corp.	New York, N. Y.
82209	Maguire Industries, Inc.	Greenwich, Conn.	87930	Tower Mfg. Corp.	Providence, R. I.	94310	Soulco Div. of S. Chester Corp.	Lester, Pa.	99313	Varian Associates	Palo Alto, Calif.
82219	Sylvania Electric Prod. Inc., Electronic Tube Div.	Emporium, Pa.	88140	Cutler-Hammer, Inc.	Lincoln, Ill.	94330	Triu Ohm Prod. Div. of Modet Engineering and Mfg. Co.	Chicago, Ill.	99515	Marshall Industries, Electron Products Division	Pasadena, Calif.
82376	Astron Co.	East Newark, N. J.	88220	Gould-National Batteries, Inc.	St. Paul, Minn.	94582	Wire Cloth Products Inc.	Chicago, Ill.	99707	Control Switch Division, Controls Co. of America	El Segundo, Calif.
82389	Switchcraft, Inc.	Chicago, Ill.	88698	General Mills, Inc.	Buffalo, N. Y.	95023	Worcester Pressed Aluminum Corp.	Worcester, Mass.	99800	Delevan Electronics Corp.	East Aurora, N. Y.
82647	Metals and Controls, Inc., Div. of Texas Instruments, Inc., Spencer Prods.	Attleboro, Mass.	89462	Waldes Kohinor, Inc.	Cambridge, Mass.	95236	Philbrick Researchers, Inc.	Boston, Mass.	99848	Wilco Corporation	Indianapolis, Ind.
82866	Research Products Corp.	Madison, Wis.	89473	General Electric Distributing Corp.	Schenectady, N. Y.	95238	Allies Products Corp.	Miami, Fla.	99934	Renbrandt, Inc.	Boston, Mass.
82877	Rotron Manufacturing Co., Inc.	Woodstock, N. Y.	89636	Carler Parts Div. of Economy Baler Co.	Chicago, Ill.	95263	Continental Connector Corp.	Woodside, N. Y.	99942	Hoffman Semiconductor Div. of Hoffman Electronics Corp.	Evanston, Ill.
82893	Vector Electronic Co.	Glendale, Calif.	89655	United Transformer Co.	Chicago, Ill.	95264	Leecraft Mfg. Co., Inc.	New York, N. Y.	99957	Technology Instrument Corp. of Calif.	Newbury Park, Calif.
83053	Western Washer Mfr. Co.	Los Angeles, Calif.	90179	U.S. Rubber Co., Mechanical Goods Div.	Passaic, N. J.	95265	Lercro Electronics, Inc.	Burbank, Calif.	THE FOLLOWING H-P VENDORS HAVE NO NUMBER ASSIGNED IN THE LATEST SUPPLEMENT TO THE FEDERAL SUPPLY CODE FOR MANUFACTURERS HANDBOOK.		
83058	Carr Fastener Co.	Cambridge, Mass.	90970	Bearing Engineering Co.	San Francisco, Calif.	95275	National Coil Co.	Sheridan, Wyo.			
83086	New Hampshire Ball Bearing, Inc.	Peterborough, N. H.	91260	Connor Spring Mfg. Co.	San Francisco, Calif.	95348	Vitamon, Inc.	Bridgeport, Conn.	J0000	Winchester Electronics, Inc.	Los Angeles, Calif.
83125	Pyramid Electric Co.	Darlington, S. C.	91345	Miller Dial & Nameplate Co.	El Monte, Calif.	95354	Gordas Corp.	Bloomfield, N. J.	0000F	Malco Tool and Die	Los Angeles, Calif.
83148	Electro Cords Co.	Los Angeles, Calif.	91418	Radio Materials Co.	Chicago, Ill.	95372	Methode Mfg. Co.	Chicago, Ill.	0000M	Western Coil Div. of Automatic Ind., Inc.	Redwood City, Calif.
83186	Victory Engineering Corp.	Springfield, N. J.	91506	Augat Brothers', Inc.	Attleboro, Mass.	95397	Dage Electric Co., Inc.	Franklin, Ind.	0000P	Ty-Car Mfg. Co., Inc.	Holliston, Mass.
83258	Bendix Corp., Red Bank Div.	Red Bank, N. J.	91637	Dale Electronics, Inc.	Columbus, Nebr.	95607	Weknesser Co.	Chicago, Ill.	0000Z	Willow Leather Products Corp.	Newark, N. J.
83315	Hubbell Corp.	Mundelein, Ill.	91862	Elco Corp.	Philadelphia, Pa.	96067	Huggins Laboratories	Sunnyvale, Calif.	000AA	British Radio Electronics Ltd.	Washington, D. C.
83330	Smith, Herman H., Inc.	Brooklyn, N. Y.	91737	Gremer Mfg. Co., Inc.	Wakefield, Mass.	96095	Hi-Q Division of Aerovox	Olean, N. Y.	000AB	ETA	England
83365	Central Screw Co.	Chicago, Ill.	91827	K F Development Co.	Redwood City, Calif.	96256	Thordarson-Meissner Div. of Maguire Industries, Inc.	Mt. Carmel, Ill.	000AC	Indiana General Corp., Elect. Div.	Indiana
83501	Gavitt Wire and Cable Co., Div. of Amerace Corp.	Brookfield, Mass.	91929	Minneapolis-Honeywell Regulator Co., Microswitch Div.	Freeport, Ill.	96296	Solar Manufacturing Co.	Los Angeles, Calif.	000BB	Precision Instrument Components Co.	Van Nuys, Calif.
83594	Bunewhite Corp., Electronic Tube Div.	Plainfield, N. J.	91961	Naha-Bros. Spring Co.	Oakland, Calif.	96330	Carlton Screw Co.	Chicago, Ill.	000MM	Rubber Eng. & Development	Hayward, Calif.
83740	Eveready Battery	New York, N. Y.	92180	Triu-Connector Corp.	Peabody, Mass.	96341	Nicrowave Associates, Inc.	Burlington, Mass.	000NN	A "N" D Manufacturing Co.	San Jose 27, Calif.
83777	Model Eng. and Mfg., Inc.	Huntington, Ind.	92196	Universal Metal Prod., Inc.	Bassett Puate, Calif.	96501	Excel Transformer Co.	Oakland, Calif.	000QQ	Cooltron	Oakland, Calif.
83821	Loyd Scroggs Co.	Festus, Mo.	92367	Elgeet Optical Co., Inc.	Rochester, N. Y.	97464	Industrial Retaining Ring Co.	Irvington, N. J.	000SS	Control of Elgin Watch Co.	Burbank, Calif.
84171	Arco Electronics, Inc.	New York, N. Y.	92607	Tinsolite Insulated Wire Co.	Tarrytown, N. Y.	97539	Automatic and Precision Mfg. Co.	Yonkers, N. Y.	000WW	California Eastern Lab.	Burlingame, Calif.
84396	A. J. Glesener Co., Inc.	San Francisco, Calif.	93332	Sylvania Electric Prod. Inc., Semiconductor Div.	Woburn, Mass.	97966	CBS Electronics, Div. of C.B.S., Inc.	Danvers, Mass.	000YY	S. K. Smith Co.	Los Angeles 45, Calif.
84411	Good All Electric Mfg. Co.	Ogallala, Neb.	93369	Robbins and Myers, Inc.	New York, N. Y.	97979	Reon Resistor Corp.	Yonkers, N. Y.			
84970	Sarkes Tarzian, Inc.	Bloomington, Ind.	93410	Stevens Mfg. Co., Inc.	Mansfield, Ohio	98141	Axel Brothers Inc.	Jamaica, N. Y.			
85454	Bouton Molding Company	Boonton, N. J.	93788	Howard J. Smith Inc.	Port Monmouth, N. J.	98159	Rubber Teck, Inc.	Gardena, Calif.			
85471	A. B. Boyd Co.	San Francisco, Calif.									

00015-39  
Revised: February, 1965

From: FSC Handbook Supplements  
H4-1 Dated DECEMBER 1964  
H4-2 Dated MARCH 1962

## APPENDIX I - MANUAL CHANGES

This manual applies directly to the 5253B Frequency Converter having serial prefix 513. This manual with the following changes also applies to the 5253B Frequency Converters having serial prefix numbers 450, 321, and 311.

Instrument Serial Prefix No.	Change No.
450	1
311, 321	1, 2

CHANGE 1: Tables 6-1, Misc., Table 6-2

Change: Plate: Bottom from 05253-0005 to ~~Ⓢ~~ Part No. 5253A-12E.  
 Bracket: Meter from 05251-0002 to ~~Ⓢ~~ Part No. 5253A-12F.  
 Bracket: Panel from 05253-0006 to ~~Ⓢ~~ Part No. 05253-0002.  
 Panel: Front from 05253-2014 to ~~Ⓢ~~ Part No. 05253-2003.

CHANGE 2: Figure 5-5, Table 6-1.

Change: A1 from 05253-6007 to 5253A-65A  
 Replace schematic with Figure IA-1  
 Replace A1 portion of parts list with Table IA-1

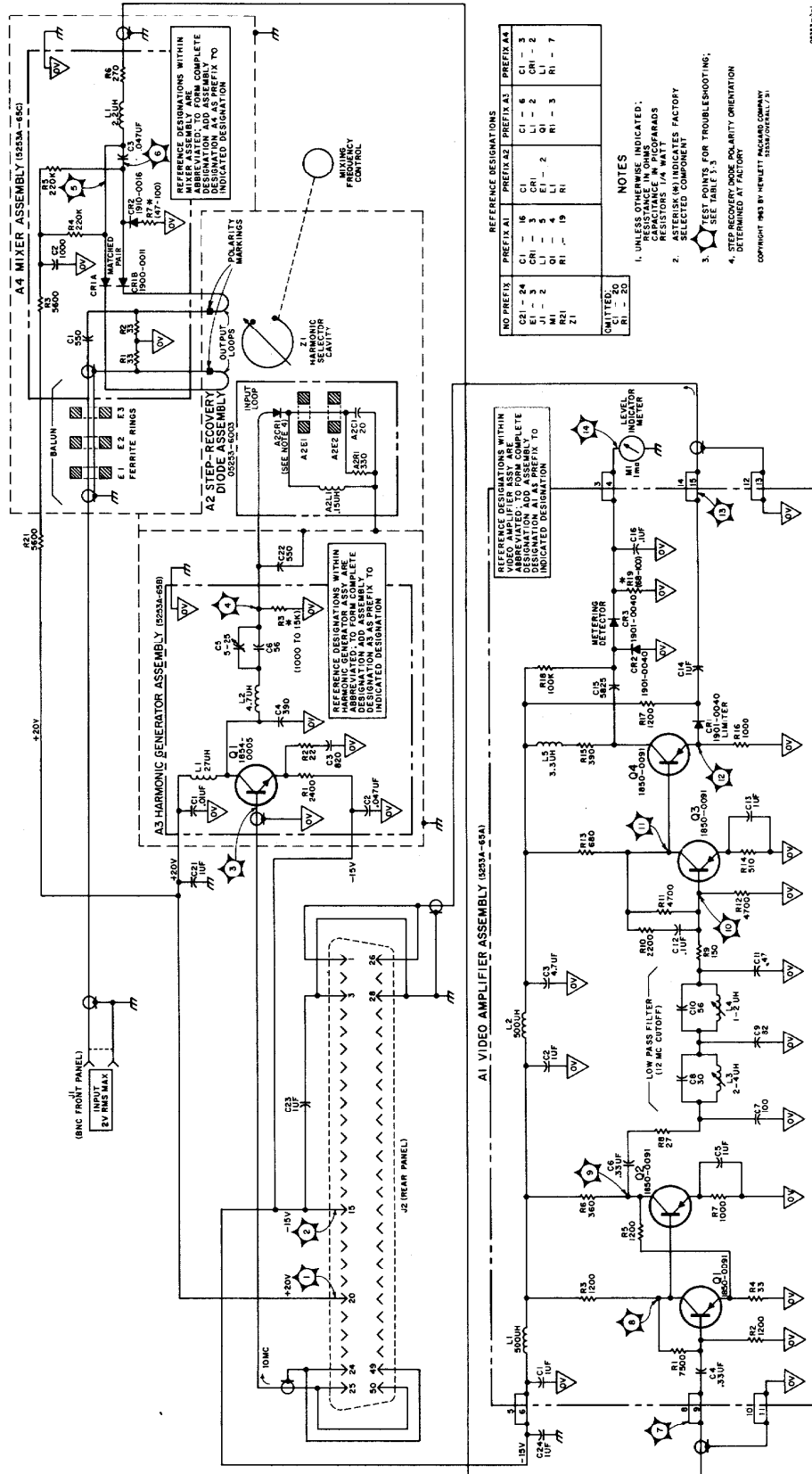

Figure IA-1



Table IA-1. Reference Designation Index

Reference Designation	Ⓢ Stock No.	Description #	Note
A1	5253A-65A	ASSY:VIDEO AMPLIFIER	
A1C1	0160-0127	C:FXD 1UF OHM 20% 25VDCW	
A1C2	0160-0127	C:FXD 1UF OHM 20% 25VDCW	
A1C3	0180-0100	C:FXD ELECT TA 4.7UF 10% 35VDCW	
A1C4	0160-0137	C:FXD CER 0.33UF 20% 25VDCW	
A1C5	0160-0127	C:FXD 1UF OHM 20% 25VDCW	
A1C6	0160-0137	C:FXD CER 0.33UF 20% 25VDCW	
A1C7	0140-0176	C:FXD MICA 100 PF 2% 300 VDCW	
A1C8	0140-0203	C:FXD MICA 30PF 5% 500VDCW	
A1C9	0140-0193	C:FXD MICA 82 PF 5% 300 VDCW	
A1C10	0140-0191	C:FXD MICA 56 PF 5% 300 VDCW	
A1C11	0140-0204	C:FXD 47PF 5% NPO 500 VDCW	
A1C12	0150-0121	C:FXD .1MF 50VDCW	
A1C13	0160-0127	C:FXD 1UF OHM 20% 25VDCW	
A1C14	0160-0127	C:FXD 1UF OHM 20% 25VDCW	
A1C15	0140-0189	C:FXD MICA 5825 PF 2% 300 VDCW	
A1C16	0150-0121	C:FXD .1MF 50VDCW	
A1CR1	1901-0040	DIODE:SILICON	
A1CR2	1901-0040	DIODE:SILICON	
A1CR3	1901-0040	DIODE:SILICON	
L1	9140-0118	COIL:FXD 500 UH 5%	
L2	9140-0118	COIL:FXD 500 UH 5%	
A1L3	9140-0126	COIL:VAR 1.76-4.02	
A1L4	9140-0125	COIL:VAR 0.9-1.9 UHY	
A1L5	9140-0111	COIL:FXD RF 3.3UHY	
A1Q1	1850-0091	TRANSISTOR:GERMANIUM 2N2048 PNP	
A1Q2	1850-0091	TRANSISTOR:GERMANIUM 2N2048 PNP	
A1Q3	1850-0091	TRANSISTOR:GERMANIUM 2N2048 PNP	
A1Q4	1850-0091	TRANSISTOR:GERMANIUM 2N2048 PNP	
A1R1	0683-7525	R:FXD COMP 7500 OHMS 5% 1/4W	
A1R2	0683-1225	R:FXD 1200 OHM 5% 1/4W	
A1R3	0683-1225	R:FXD 1200 OHM 5% 1/4W	
A1R4	0683-3305	R:FXD COMP 33 OHMS 5% 1/4W	
A1R5	0683-1225	R:FXD COMP 1200 OHMS 5% 1/4W	
A1R6	0683-3615	R:FXD COMP 360 OHMS 5% 1/4W	
A1R7	0683-1025	R:FXD COMP 1000 OHMS 5% 1/4W	
A1R8	0684-2701	R:FXD 27 OHM 10% 1/4 W	
A1R9	0684-1511	R:FXD COMP 15K OHMS 10% 1/4W	
A1R10	0683-2225	R:FXD 2.2K OHM 5% 1/4W	
A1R11	0683-4725	R:FXD COMP 4700 OHMS 5% 1/4W	
A1R12	0683-4725	R:FXD COMP 4700 OHMS 5% 1/4W	
A1R13	0683-6815	R:FXD COMP 680 OHMS 5% 1/4W	
A1R14	0683-5115	R:FXD COMP 510 OHMS 5% 1/4W	
A1R15	0683-3915	R:FXD COMP 390 OHMS 5% 1/4W	
A1R16	0683-1025	R:FXD COMP 1000 OHMS 5% 1/4W	
A1R17	0683-1225	R:FXD 1200 OHM 5% 1/4W	
A1R18	0684-1041	R:FXD 100 K OHM 10% 1/4 W	
A1R19	0683-8205	R:FXD COMP 82 OHMS 5% 1/4W	

# See list of abbreviations in introduction to this section

## APPENDIX II - 5253A

### IIA-1. INTRODUCTION.

IIA-2. The 5253A is basically the same as the 5253B except for frequency range. The 5253A measures from 100 to 500 Mc. The 5253B measures from 50 to 500 Mc. The frequency range of the 5253B was extended by changing the pick-up loop in the cavity. The 5253B manual will apply for most applications. Appendix II covers the differences between the two models and contains the necessary information for the operation and maintenance of the 5253A.

### IIA-3. DESCRIPTION.

IIA-4. The Hewlett-Packard Model 5253A Frequency Converter is a plug-in unit which converts a Hewlett-Packard Model 5243L or 5245L Electronic Counter into a direct reading counter from 88 to 512 Mc.

IIA-5. The stability and accuracy of the basic counter are retained by multiplying a 10-Mc signal, derived from the 1-Mc internal time base of the counter, to a selectable harmonic frequency between 100 and 500 Mc. This known harmonic of 10 Mc is then heterodyned with the INPUT signal. If the resulting difference frequency is between 100 kc and 12 Mc (bandwidth of amplifier in plug-in), it is counted and displayed by the counter. The frequency of the INPUT signal is then indicated by the combination of the MIXING FREQUENCY control (in megacycles; front panel of plug-in) and the digital display of the counter (in megacycles).

IIA-6. A front panel meter, by monitoring the difference-frequency output of the plug-in to the counter,

aids in selecting the desired MIXING FREQUENCY and also in determining if INPUT signal amplitude is adequate for accurate frequency measurement.

### IIA-7. OPERATING PROCEDURE.

#### IIA-8. NORMAL RANGE MEASUREMENTS.

IIA-9. Figure IIA-1 is the procedure to be used for measurement of frequencies from 100.1 to 512 Mc with INPUT signal amplitudes from 50 mv to 1 v RMS.

#### IIA-10. EXTENDED RANGE MEASUREMENTS.

IIA-11. The frequency of signals not within the normal range of 100.1 to 512 Mc, 50 mv to 1 v RMS, may be measured using the following procedures:

IIA-12. 88 TO 100.1 MC, 50 MV TO 1 V RMS. Perform steps 1 through 5 of Figure IIA-1. Then:

- a. Set mixing frequency control to slightly more than 110 Mc.
- b. Turn mixing frequency control slowly clockwise until level indicator meter first reaches a maximum reading in the green portion of the scale.
- c. Subtract counter display (in Mc) from reading of mixing frequency control (in Mc) for frequency of INPUT signal.

Table IIA-1. Specifications\*

<p>RANGE: As converter for 5243L or 5245L counter, 88 Mc to 512 Mc, using mixing frequencies of 100 Mc to 500 Mc in 10 Mc steps</p> <p>ACCURACY: Retains accuracy of 5243L or 5245L counter</p> <p>INPUT VOLTAGE RANGE: 50 mv to 1 v RMS</p> <p>MAXIMUM INPUT: 2 v RMS or 100 vdc will not damage the instrument</p> <p>INPUT IMPEDANCE: Approximately 50 ohms</p> <p>LEVEL INDICATOR: Meter aids frequency selection; indicates output voltage level to counter</p> <p>REGISTRATION: Counter display is added to the converter dial reading</p> <p>WEIGHT: Net 5-1/2 lbs, shipping 9 lbs</p> <p>ACCESSORY FURNISHED:  10503A (AC-16K) Cable, 4 ft long, male BNC connectors</p> <p>*When installed in Hewlett-Packard Model 5243L or Model 5245L Electronic Counter.</p>
---

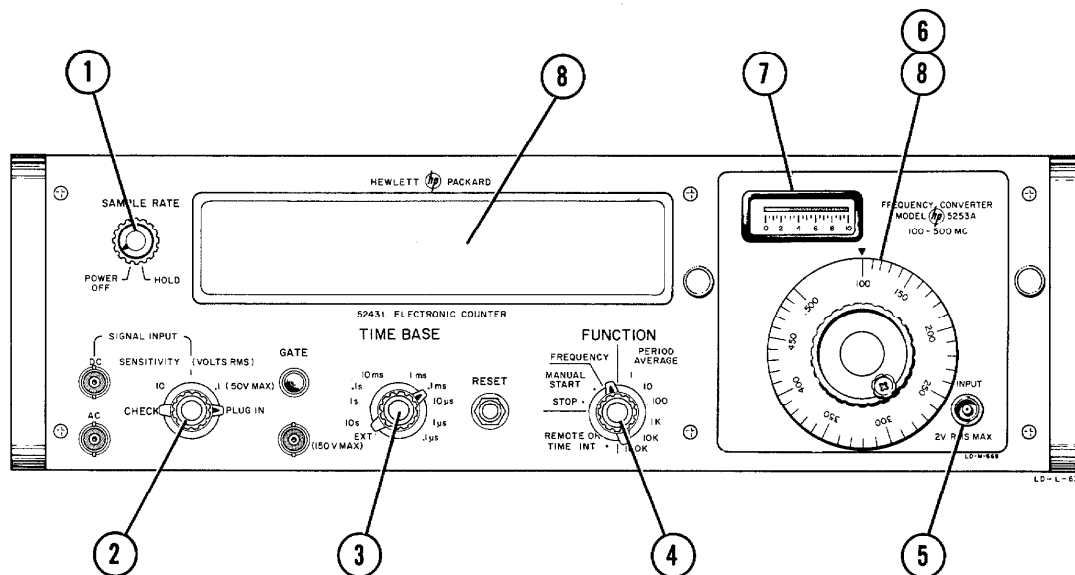

1. Turn SAMPLE RATE control slightly out of POWER OFF position.
2. Set SENSITIVITY to PLUG IN.
3. Set TIME BASE to .1 ms.\*
4. Set FUNCTION to FREQUENCY.
5. Connect signal whose frequency is to be measured to INPUT of converter.
6. Set mixing frequency control to read slightly less than 100 mc.
7. Slowly turn mixing frequency control counter-clockwise until level indicator meter first reaches a maximum reading in the green portion of its scale.
8. Add counter display (in mc) to mixing frequency control reading (in mc) for frequency of INPUT signal.

\* TIME BASE setting may vary, depending on desired resolution of INPUT signal frequency. See table 3-1.

Figure IIA-1. Frequency Measurement Procedure

IIA-13. 88 TO 512 MC, AMPLITUDE LESS THAN 50 MV RMS. The front panel level indicator meter indicates in the green portion of its scale only when converter is properly tuned and amplitude of INPUT signal is adequate for accurate frequency measurement. However, because of conservative specifications of both the converter and counter, frequencies may often be accurately measured when meter reads in the red portion of its scale. To make these extended range measurements:

a. Follow normal procedure (Figure IIA-1 or Paragraph IIA-12, depending upon frequency range) except that mixing frequency control should be tuned for first maximum reading on the level indicator meter, regardless of the color of region maximum.

b. Insert an external variable attenuator (such as Hewlett-Packard Model 355A or 355C) in the transmission line between the converter and the source of INPUT signal. Vary attenuation from 0 to 1 db during final step of frequency measurement procedure. If counter display does not change more than momentarily (during switching of attenuator), INPUT signal is above noise threshold and frequency measurement result is valid.

#### IIA-14. VIDEO AMPLIFIER ASSEMBLY (A1).

IIA-15. The output of the mixer circuit is amplified by transistors A1Q1 and A1Q2 and is fed to the 12-Mc low-pass filter network (see Figure IIA-2). This filter passes any signal frequency below approximately 12 Mc and attenuates all higher frequency signals. The low-pass filter output is amplified by A1Q3 and fed to the last transistor amplifier, A1Q4, which provides both the output to the counter and the drive for the level indicator meter. The limiter diode, A1CR1, prevents the amplitude of the video amplifier output signal from exceeding approximately 300 mv RMS so that counter input circuits will not be overloaded. The low frequency limit of the video amplifier, determined by the bypass and interstage coupling networks, is approximately 100 kc. The converter output signal to the counter, when converter is properly tuned, will be between approximately 100 kc and 12 Mc and will have an amplitude that is less than approximately 300 mv RMS.

#### IIA-16. LEVEL INDICATOR METER .

IIA-17. The dc current supply for the meter is produced by metering detector A1CR3 and smoothed by capacitor A1C16 (see Figure IIA-3). The value of shunt resistor A1R19 is selected to make level indicator meter M1 read at red-green border when amplitude of converter output to counter is in excess of the 100-mv RMS minimum signal amplitude normally required by the counter for accurate frequency measurement.

#### IIA-18. HARMONIC GENERATOR ADJUSTMENT.

IIA-19. To adjust the harmonic generator assembly, proceed as follows:

a. Remove converter from counter and reconnect to counter with Extension Cable,  $\text{C} 10506\text{A}$ .

b. Connect VHF Signal Generator to converter INPUT and set to 472 Mc, CW, at 100 mv.

c. Connect RF Millivoltmeter to Test Point #13 (see Figure IIA-5).

d. Set converter mixing frequency control to 470 Mc, and tune for maximum reading on RF Millivoltmeter.

e. Vary output of VHF Signal Generator to make converter level indicator meter read at red-green border.

f. Using plastic tuning tool, tune A3C5 (see Figure IIA-5) for maximum reading on RF Millivoltmeter. Tune A3C5 through hole in harmonic generator assembly shield cover.

#### IIA-20. LOW PASS FILTER ADJUSTMENT.

IIA-21. To adjust the low pass filter in the video amplifier assembly, proceed as follows:

a. Remove converter from counter and reconnect to counter with Extension Cable,  $\text{C} 10506\text{A}$ .

b. Connect VHF Signal Generator to converter INPUT and set to 110 Mc, CW, at 50 mv.

c. Connect RF Millivoltmeter to Test Point #13 (see Figure IIA-7).

d. Set converter mixing frequency control to 100 Mc and tune for maximum reading on RF Millivoltmeter.

e. Set Signal Generator to 118 Mc, CW, at 1 v.

f. Using plastic tool, adjust variable inductor ALL4 (see Figure IIA-4) for minimum reading of RF Millivoltmeter.

g. Set Signal Generator to 117 Mc, CW, at 1 v.

h. Using plastic tool, adjust variable inductor ALL3 (see Figure IIA-4) for minimum reading of RF Millivoltmeter.

i. Set Signal Generator to 115 Mc, CW, at 1 v.

j. Reading of RF Millivoltmeter should be less than 100 mv. If reading is above 100 mv, troubleshoot video amplifier assembly.

#### IIA-22. METER ADJUSTMENT.

a. Turn counter power off, remove converter from counter, and reconnect to counter with Extension Cable,  $\text{C} 10506\text{A}$ .

b. Set VHF Signal Generator to 102 Mc, CW, at 50 mv and connect to INPUT of converter.

c. Set counter controls as shown in Figure IIA-1. Counter should display approximately 2 Mc.

d. Vary VHF Generator output to make level indicator meter read at red-green border.

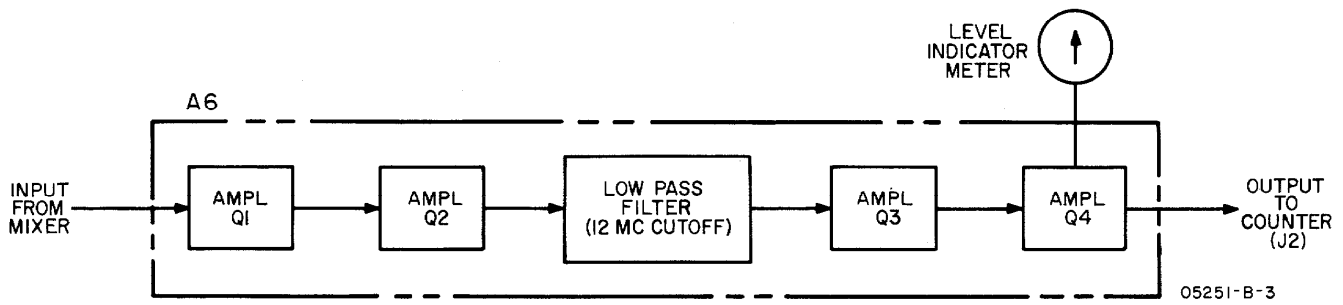

Figure IIA-2. Video Amplifier (A6)

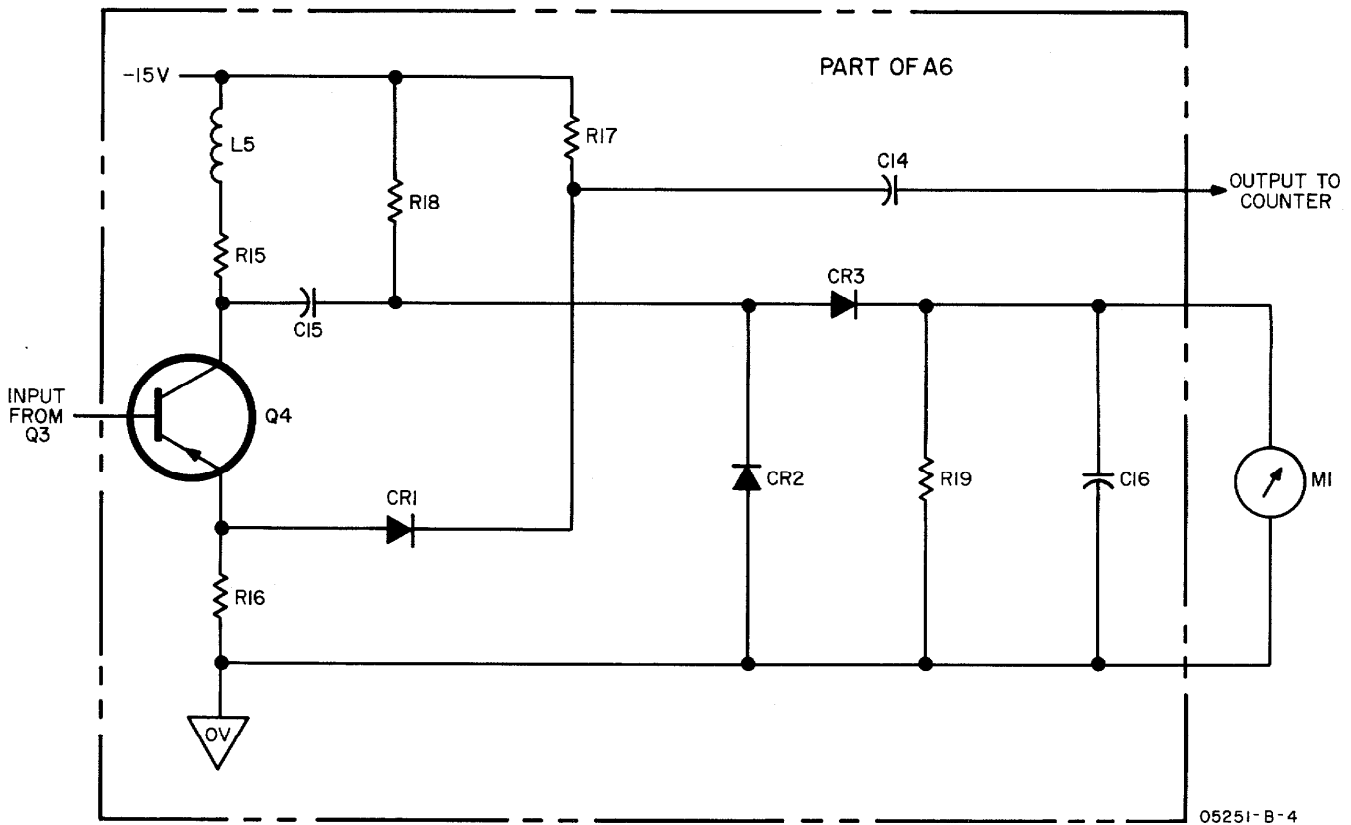

Figure IIA-3. Level Indicator Meter Circuit

e. Using RF Millivoltmeter, measure voltage at Test Point #13. Voltage should be between 100 mv and 130 mv. If not, change value of resistor A1R19 to change voltage to between 100 mv and 130 mv. If voltage is too high, increase value of A1R19. If voltage is too low, decrease value of A1R19. Repeat steps d and e after changing value of A1R19.

### **IIA-23. MECHANICAL ADJUSTMENT OF METER ZERO .**

IIA-24. TRUE SIGNAL LEVEL INDICATION. Level indicator meter is adjusted at the factory for proper mechanical zero. However, normal aging of meter components may change indicated zero level. To insure accuracy of input signal level indication, periodic adjustment of meter zero may be necessary.

IIA-25. ZERO-SET. When meter is properly zero-set, pointer rests over the zero calibration mark at the left-hand end of meter scale when converter is (1) at normal operating temperature, (2) in normal operating position, and (3) without power. Proceed as follows:

- a. Allow counter and converter to operate for one hour to permit meter movement to reach normal operating temperature.
- b. Turn counter off and allow one minute for all capacitors to discharge.
- c. Remove converter from counter to enable access to rear of meter.
- d. Remove adhesive-backed-paper cover from meter zero-adjustment access hole on top-rear of meter.
- e. Carefully insert small tool in access hole and engage adjustment fork.
- f. Vary setting of adjustment fork until meter reads zero.
- g. Remove tool and replace adhesive-backed paper cover on access hole. This completes meter zero adjustment procedure.

### **IIA-26. SENSITIVITY CHECK.**

- a. Turn counter power off, remove converter from counter, and reconnect to counter with Extension Cable,  $\text{HP}$  10506A.
- b. Set VHF Signal Generator to 102 Mc, CW, at 50 mv and connect to INPUT of converter.
- c. Adjust controls as shown in Figure IIA-2.
- d. Set converter mixing frequency control to 100 Mc. Counter should display approximately 2 Mc.
- e. Using RF Millivoltmeter, measure output of converter at Test Point #13 (see Figure IIA-7). Voltage should be at least 100 mv.

f. Repeat above steps c, d, and e with VHF Generator frequency of 472 Mc and converter mixing frequency control set to 470 Mc. Converter output to counter, as measured by RF Millivoltmeter, should be at least 100 mv.

g. A similar check may be made at any frequency within the range of the Model 5253A. Converter output to counter should be at least 100 mv when difference frequency is between 100 kc and 12 Mc and converter is properly tuned.

### **IIA-27. METER ACCURACY CHECK.**

a. Turn counter power off, remove converter from counter, and reconnect to counter with Extension Cable,  $\text{HP}$  10506A.

b. Set VHF Signal Generator to 102 Mc, CW, at 50 mv and connect to INPUT of converter.

c. Set controls as shown in Figure IIA-1. Set converter mixing frequency control to 100 Mc. Counter should display approximately 2 Mc.

d. Vary output of VHF Signal Generator for converter level indicator to make meter read at red-green border.

e. Using RF Millivoltmeter, measure converter output to counter at Test Point #13. Voltage should be between 100 mv and 130 mv. If not, see Paragraph IIA-21 for meter calibration adjustment procedure.

### **IIA-28. LOW PASS FILTER CHECK.**

- a. Turn counter power off, remove converter from counter and reconnect to counter with Extension Cable,  $\text{HP}$  10506A.
- b. Set VHF Signal Generator to 110 Mc, CW, at 50 mv and connect to INPUT of converter.
- c. Set controls as shown in Figure IIA-1. Set converter mixing frequency control to 100 Mc. Counter should display approximately 10 Mc.
- d. Connect RF Millivoltmeter to Test Point #13. Vary output of VHF Signal Generator for RF Millivoltmeter reading of 100 mv. Note output level of VHF Signal Generator.
- e. Set VHF Signal Generator to 115 Mc at same output level as noted in step d above. Converter output to counter, as shown on RF Millivoltmeter, should not exceed 50 mv. If converter output to counter is greater than 50 mv, see Paragraph IIA-20 for low pass filter adjustment procedure.

**IIA-29. IN-CABINET PERFORMANCE CHECK.**

- a. Turn counter power off and install converter.
- b. Set VHF Signal Generator to 102 Mc, CW, at 50 mv and connect to INPUT of converter.

c. Set controls as shown in Figure IIA-1. Counter should display approximately 2 Mc.

d. Set VHF Signal Generator to any frequency between 88 Mc and 512 Mc with output of 50 mv. Counter should display correct frequency at any frequency within this range.

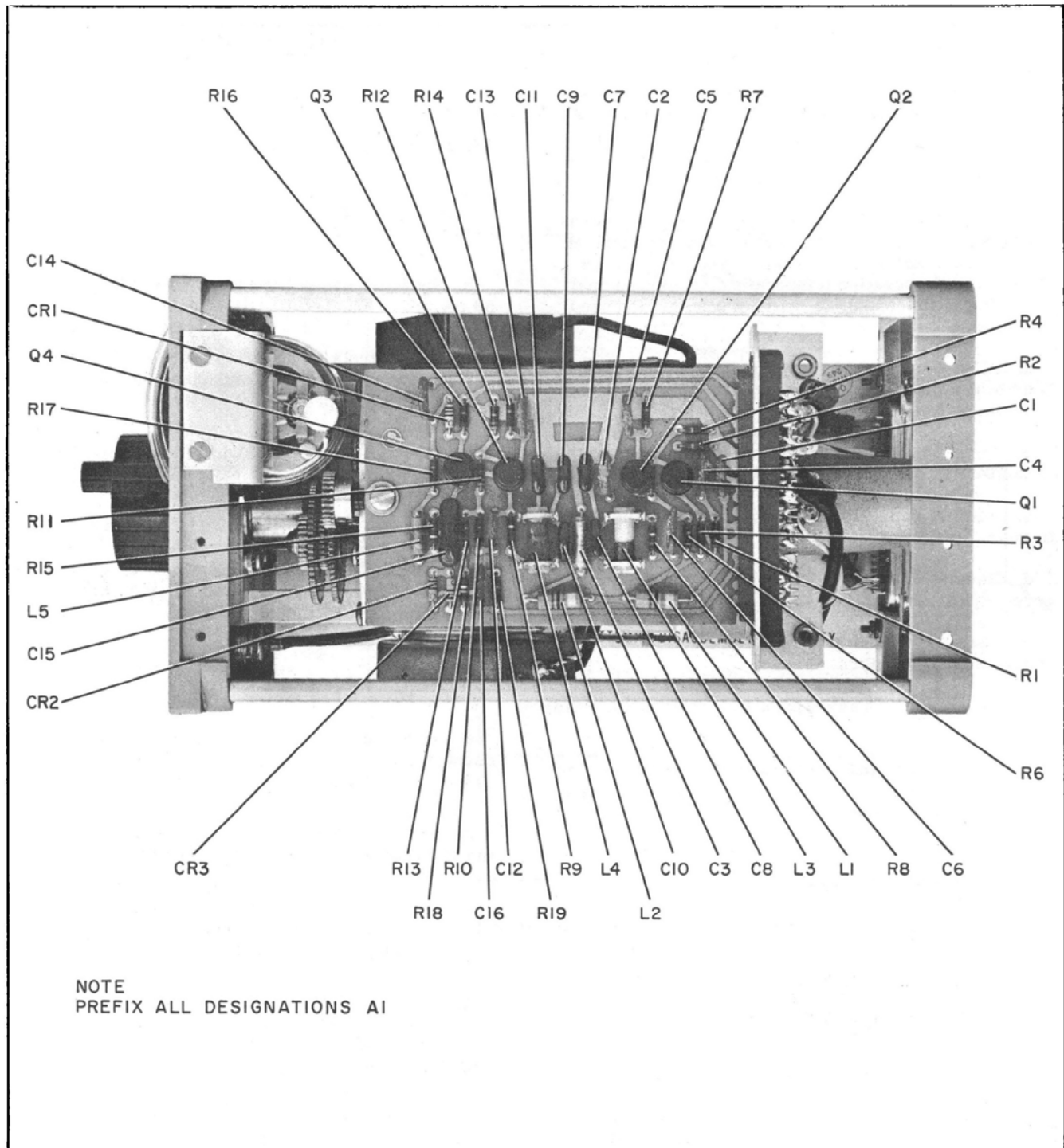

Figure IIA-4. Model 5253A, Top View

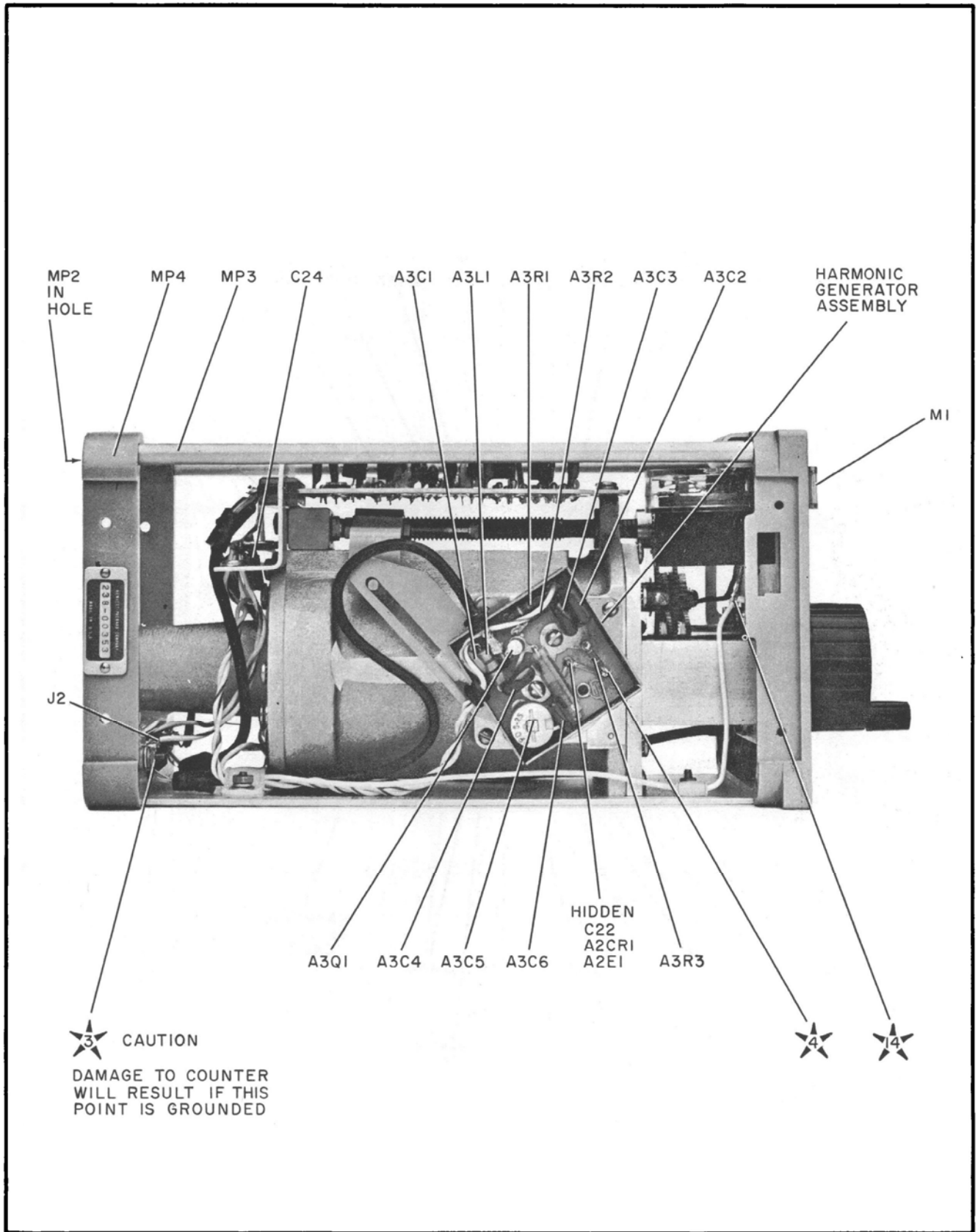

Figure IIA-5. Left Side View



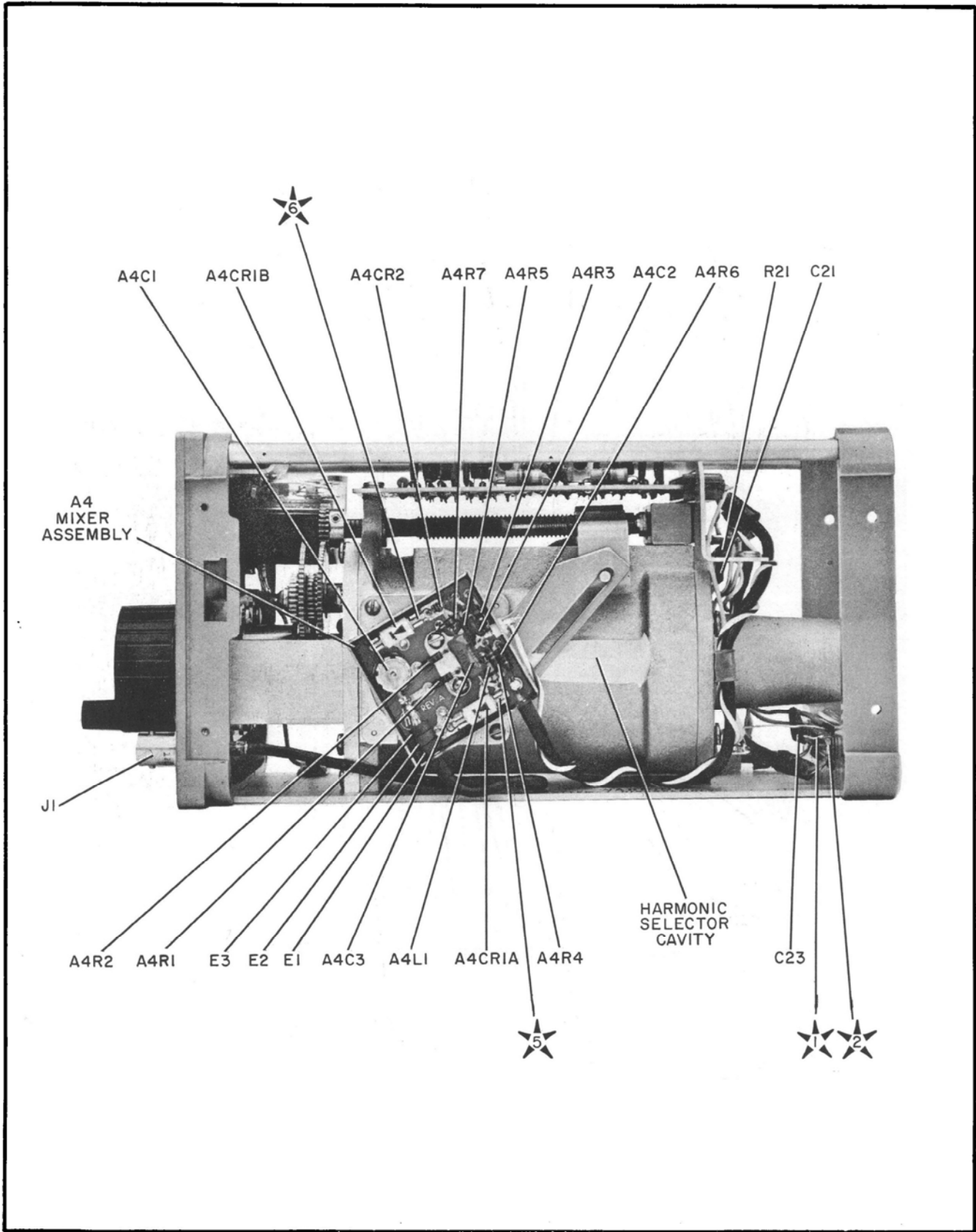

Figure IIA-6. Right Side View

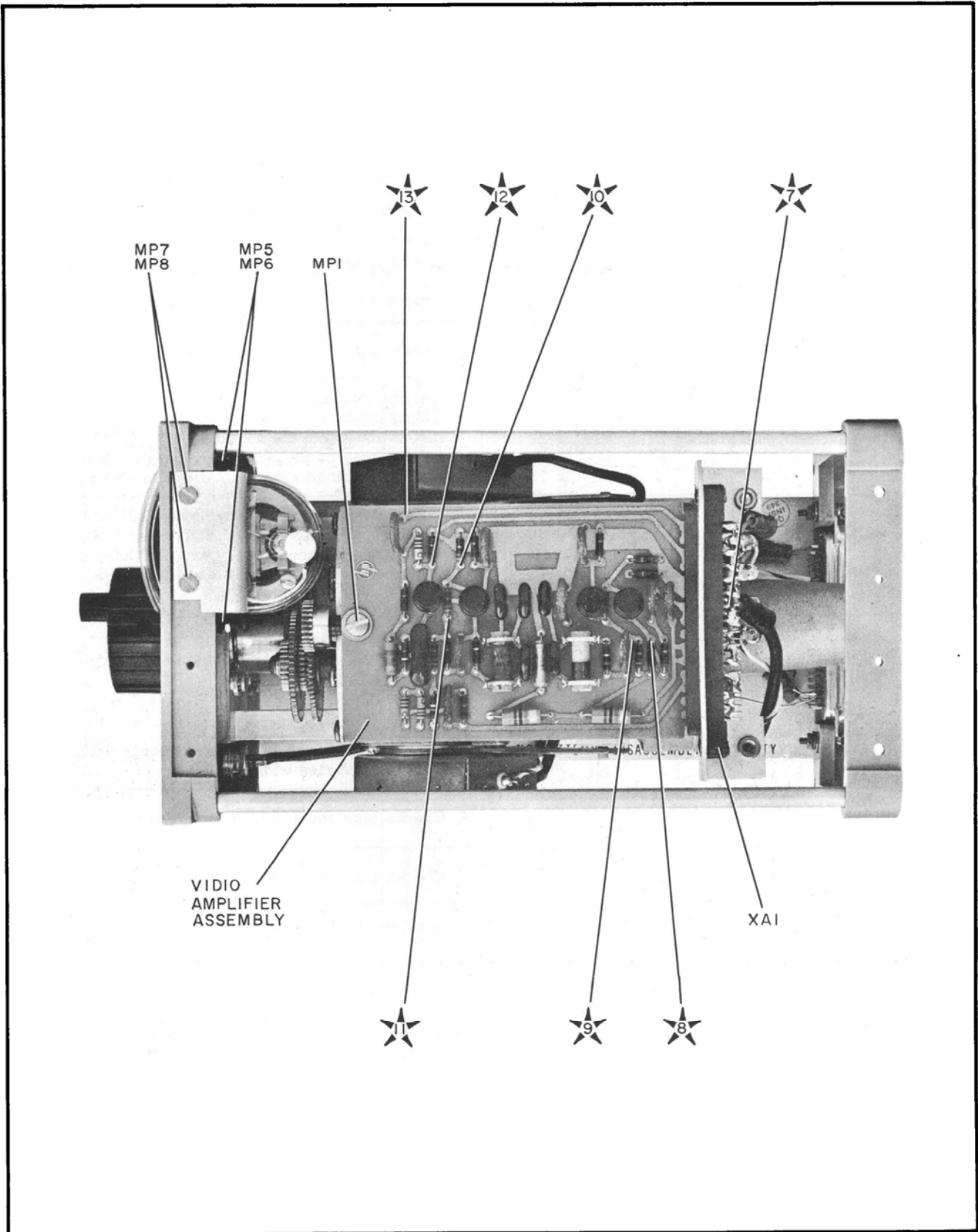

Figure IIA-7. Top View - Test Points

Table IIA-2. Troubleshooting Procedure

All voltages given are approximate and may vary from instrument to instrument because of variations in component characteristics.

TEST EQUIPMENT:  $\text{\textcircled{P}}$  Model 411A RF Millivoltmeter with  $\text{\textcircled{P}}$ 11022A (formerly 411A-21B) Pen Type Probe Tip,  
 $\text{\textcircled{P}}$  Model 412A DC VTVM

REMOVE $\text{\textcircled{P}}$ 5253A FROM COUNTER; SELF-CHECK COUNTER	See counter manual for self-check procedure.
CONNECT $\text{\textcircled{P}}$ 5253A TO COUNTER WITH EXTENSION CABLE, $\text{\textcircled{P}}$ 10506A (formerly AC-16Y)	Extension cable available from $\text{\textcircled{P}}$ ; see parts list.
$\text{\textcircled{1}}$ +20 VDC $\text{\textcircled{2}}$ -15 VDC	Checks power supplied to plug-in from counter; see counter manual for power supply adjustment procedure.
$\text{\textcircled{3}}$ + 6 VDC 2 VAC	Checks 10-Mc drive of harmonic generator.
$\text{\textcircled{4}}$ + 2 VDC - 2 VAC	Checks generator diode drive. Voltages vary widely because of both the detuning effect of voltmeter probe and the variable value of A3R3. DC voltage may be either + or -, depending upon factory determined generator diode orientation.
$\text{\textcircled{5}}$ +100 MV DC $\text{\textcircled{6}}$ +100 MV DC	Voltages vary widely because of diode characteristics. Voltages are 0 VDC when diode shorted, and +20 VDC when diode open. Voltages should be approximately equal because of matched characteristics.

CONNECT SIGNAL GENERATOR TO  $\text{\textcircled{P}}$ 5253A.  
 SET GENERATOR TO 102 MC, CW, 100 MV.  
 SET COUNTER CONTROLS AND 5253A TO  
 MEASURE FREQUENCY OF INPUT SIGNAL.

$\text{\textcircled{7}}$ 5 MV RMS	This voltage is total harmonic energy output of mixer and varies widely.
$\text{\textcircled{8}}$ -6 VDC 15 MV RMS	Checks bias and amplification of A1Q1
$\text{\textcircled{9}}$ -10 VDC 200 MV RMS	Checks bias and amplification of A1Q2
$\text{\textcircled{10}}$ -4 VDC 15 MV RMS	General check of low pass filter section
$\text{\textcircled{11}}$ -9 VDC 500 MV RMS	Checks bias and amplification of A1Q3
$\text{\textcircled{12}}$ -8.5 VDC 300 MV RMS	Checks operation of A1Q4
$\text{\textcircled{13}}$ 0 VDC 200 MV RMS	Checks operation of limiter, A1CR1
$\text{\textcircled{14}}$ 0 MV DC WHEN METER READS AT LEFT END OF SCALE; 50 MV DC WHEN METER READS FULL SCALE; 15 MV DC WHEN TEST POINT #13 IS 100 MV RMS, AND METER READS AT RED-GREEN BORDER.	Checks accuracy of meter circuit in relation to output to counter

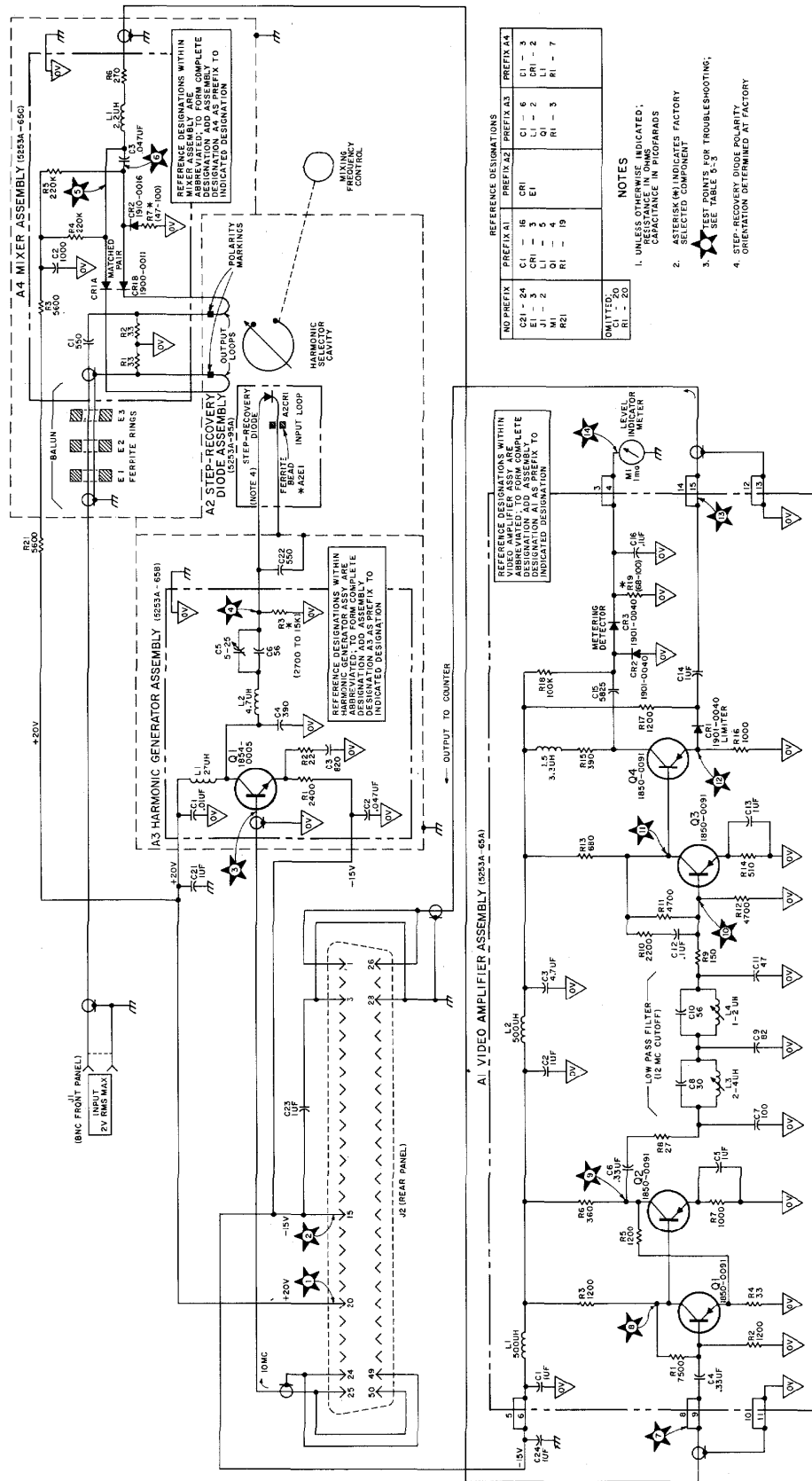

Figure IIA-8. Schematic Diagram

Table IIA-3. Reference Designation Index

Reference Designation	Ⓢ Stock No.	Description #	Note
A1	5253A-65A	ASSY:VIDEO AMPLIFIER	
A1C1	0160-0127	C:FXD CER 1.0 UF 20% 25VDCW	
A1C2	0160-0127	C:FXD CER 1.0 UF 20% 25VDCW	
A1C3	0180-0100	C:FXD ELECT TA 4.7 UF 10% 35VDCW	
A1C4	0160-0137	C:FXD CER 0.33 UF 20% 25VDCW	
A1C5	0160-0127	C:FXD CER 1.0 UF 20% 25VDCW	
A1C6	0160-0137	C:FXD CER 0.33 UF 20% 25VDCW	
A1C7	0140-0176	C:FXD MICA 100 PF 2% 300VDCW	
A1C8	0140-0203	C:FXD MICA 30 PF 5% 500VDCW	
A1C9	0140-0193	C:FXD MICA 82 PF 5% 300VDCW	
A1C10	0140-0191	C:FXD MICA 56 PF 5% 300VDCW	
A1C11	0140-0204	C:FXD MICA 47 PF 5% NPO 500VDCW	
A1C12	0150-0121	C:FXD CER 0.1 UF +80-20% 50VDCW	
A1C13	0160-0127	C:FXD CER 1.0 UF 20% 25VDCW	
A1C14	0160-0127	C:FXD CER 1.0 UF 20% 25VDCW	
A1C15	0140-0189	C:FXD MICA 5825 PF 2% 300VDCW	
A1C16	0150-0121	C:FXD CER 0.1 UF +80-20% 50VDCW	
A1CR1	1901-0040	DIODE:SILICON	
A1CR2	1901-0040	DIODE:SILICON	
A1CR3	1901-0040	DIODE:SILICON	
A1L1	9140-0118	COIL:500MH 5%	
A1L2	9140-0118	COIL:500 MH 5%	
A1L3	9140-0126	COIL:VAR 1.76-4.02 UH	
A1L4	9140-0125	COIL:VAR 0.9-1.9 UH	
A1L5	9140-0111	COIL:FXD RF 3.3 UH	
A1Q1	1850-0091	TRANSISTOR:GERMANIUM PNP 2N2048	
A1Q2	1850-0091	TRANSISTOR:GERMANIUM PNP 2N2048	
A1Q3	1850-0091	TRANSISTOR:GERMANIUM PNP 2N2048	
A1Q4	1850-0091	TRANSISTOR:GERMANIUM PNP 2N2048	
A1R1	0683-7525	R:FXD COMP 7500 OHM 5% 1/4W	
A1R2	0683-1225	R:FXD COMP 1200 OHM 5% 1/4W	
A1R3	0683-1225	R:FXD COMP 1200 OHM 5% 1/4W	
A1R4	0683-3305	R:FXD COMP 33 OHM 5% 1/4W	
A1R5	0683-1225	R:FXD COMP 1200 OHM 5% 1/4W	
A1R6	0683-3615	R:FXD COMP 360 OHM 5% 1/4W	
A1R7	0683-1025	R:FXD COMP 1000 OHM 5% 1/4W	
A1R8	0684-2701	R:FXD COMP 27 OHM 10% 1/4W	
A1R9	0684-1511	R:FXD COMP 150 OHM 10% 1/4W	
A1R10	0683-2225	R:FXD COMP 2.2K OHM 5% 1/4W	
A1R11	0683-4725	R:FXD COMP 4700 OHM 5% 1/4W	
A1R12	0683-4725	R:FXD COMP 4700 OHM 5% 1/4W	
A1R13	0683-6815	R:FXD COMP 680 OHM 5% 1/4W	
A1R14	0683-5115	R:FXD COMP 510 OHM 5% 1/4W	
A1R15	0683-3915	R:FXD COMP 390 OHM 5% 1/4W	
A1R16	0683-1025	R:FXD COMP 1000 OHM 5% 1/4W	
A1R17	0683-1225	R:FXD COMP 1200 OHM 5% 1/4W	
A1R18	0684-1041	R:FXD COMP 100K OHM 10% 1/4W	
A1R19	0683-8205	R:FXD COMP 82 OHM 5% 1/4W	
		FACTORY SELECTED PART; TYPICAL VALUE GIVEN	

# See list of abbreviations in introduction to this section

Table IIA-3. Reference Designation Index (Cont'd)

Reference Designation	Ⓢ Stock No.	Description #	Note
A2	5253A-95A	ASSY:STEP RECOVERY DIODE NOT RECOMMENDED FOR FIELD REPLACEMENT	
A2CR1	1901-0120	DIODE:STEP RECOVERY,SPECIALLY SELECTED PART.	
A2E1		CORE:TOROID,SPECIALLY SELECTED PART.	
A3	5253A-65B	ASSY:HARMONIC GENERATOR	
A3C1	0150-0093	C:FXD CER 0.01 UF +80-20% 100VDCW	
A3C2	0170-0094	C:FXD MY 0.047 UF 20% 50VDCW	
A3C3	0140-0151	C:FXD MYCA 820 PF 2% 300VDCW	
A3C4	0140-0200	C:FXD MICA 390 PF 5% 300VDCW	
A3C5	0130-0016	C:VAR CER 5-25 PF NPO	
A3C6	0140-0191	C:FXD MICA 56 PF 5% 300VDCW	
A3L1	9140-0107	COIL:FXD RF 27 UH	
A3L2	9140-0025	COIL:FXD RF 4.7 UH	
A3R1	0686-2425	R:FXD COMP 2400 OHM 5% 1/2W	
A3R2	0683-2205	R:FXD COMP 22 OHM 5% 1/4W	
A3R3	0683-5625	R:FXD COMP 5600 OHM 5% 1/4W FACTORY SELECTED PART;TYPICAL VALUE GIVEN	
A4	5253A-65C	ASSY:MIXER DOES NOT CONTAIN A4CR1, ORDER SEPARATELY	
A4C1	0140-0069	C:FXD MICA 550 PF 10% 500VDCW	
A4C2	0150-0050	C:FXD CER 1000 PF 600VDCW	
A4C3	0170-0040	C:FXD MY 0.047 UF 10% 200VDCW	
A4CR1	1900-0011	DIODE:SILICON 1N4168M, MATCHED PAIR	
A4CR2	1910-0016	DIODE:GERMANIUM 1 MICROSEC 60 WIV	
A4L1	9140-0142	COIL:FXD RF 2.2 UH	
A4R1	0683-3305	R:FXD COMP 33 OHM 5% 1/4W	
A4R2	0683-3305	R:FXD COMP 33 OHM 5% 1/4W	
A4R3	0684-5621	R:FXD COMP 5.6K OHM 10% 1/4W	
A4R4	0683-2245	R:FXD COMP 220K OHM 5% 1/4W	
A4R5	0683-2245	R:FXD COMP 220K OHM 5% 1/4W	
A4R6	0683-2715	R:FXD COMP 270 OHM 5% 1/4W	
A4R7	0683-6205	R:FXD COMP 62 OHM 5% 1/4W FACTORY SELECTED APRT;TYPICAL VALUE GIVEN	
C21	0160-0127	C:FXD CER 1.0 UF 20% 25VDCW	
C22	0140-0069	C:FXD MICA 550 PF 10% 500VDCW	
C23	0160-0127	C:FXD CER 1.0 UF 20% 25VDCW	
C24	0160-0227	C:FXD CER 1.0 UF 20% 25VDCW	
E1	9170-0059	CORE:TOROID	
E2	9170-0059	CORE:TOROID	
E3	9170-0059	CORE:TOROID	
J1	1250-0102	CONNECTOR:BNC	
J2	1251-0099	CONNECTOR:50-PIN MINIATURE	
R21	0684-5621	R:FXD COMP 5600 OHM 10% 1/4W	
XA1	1251-0135	CONNECTOR:15 CONTACTS	

# See list of abbreviations in introduction to this section

Table IIA-4. Replaceable Parts

Stock No.	Description #	Mfr.	Mfr. Part No.	TQ
5253A-65A	ASSY:VIDEO AMPLIFIER	28480	5253A-65A	1
5253A-65B	ASSY:HARMONIC GENERATOR	28480	5253A-65B	1
5253A-65C	ASSY:MIXER	28480	5253A-65C	1
5253A-95A	ASSY:STEP RECOVERY DIODE	28480	5253A-95A	1
0130-0016	C:VAR CER 5-25 PF NPO	28480	0130-0016	1
0140-0069	C:FXD MICA 550 PF 10% 500VDCW	00853	TYPE M100 E10	2
0140-0151	C:FXD MICA 820 PF 2% 300VDCW	04062	DM15F 821G	1
0140-0176	C:FXD MICA 100 PF 2% 300VDCW	04062	DM15F 101G 300V	1
0140-0189	C:FXD MICA 5825 PF 2% 300VDCW	04062	DM20F 5825G	1
0140-0191	C:FXD MICA 56 PF 5% 300VDCW	04062	DM15E 560J 300V	2
0140-0193	C:FXD MICA 82 PF 5% 300VDCW	04062	DM15E 820J 300V	1
0140-0200	C:FXD MICA 390 PF 5% 300VDCW	04062	DM15F 391J 300V	1
0140-0203	C:FXD MICA 30 PF 5% 500VDCW	04062	DM15E 300J 500V	1
0140-0204	C:FXD MICA 47 PF 5% NPO 500VDCW	04062	DM15E 470J	1
0150-0050	C:FXD CER 1000 PF 600VDCW	18486	TYPE E	1
0150-0093	C:FXD CER 0.01 UF +80-20% 100VDCW	91418	TA	1
0150-0121	C:FXD CER 0.1 UF +80-20% 50VDCW	56289	5C50A	2
0160-0127	C:FXD CER 1.0 UF 20% 25VDCW	56289	5C13	8
0160-0137	C:FXD CER 0.33 UF 20% 25VDCW	56289	5C10	2
0170-0040	C:FXD MY 0.047 UF 10% 200VDCW	56289	192P47392	1
0170-0094	C:FXD MY 0.047 UF 20% 50VDCW	84411	TYPE 602	1
0180-0100	C:FXD ELECT TA 4.7 UF 10% 35VDCW	56289	1500475X9035B2	1
0683-1025	R:FXD COMP 1000 OHM 5% 1/4W	01121	CB 1025	2
0683-1225	R:FXD COMP 1200 OHM 5% 1/4W	01121	CB 1225	4
0683-2205	R:FXD COMP 22 OHM 5% 1/4W	01121	CB 2205	1
0683-2225	R:FXD COMP 2.2K OHM 5% 1/4W	01121	CB 2225	1
0683-2245	R:FXD COMP 220K OHM 5% 1/4W	01121	CB 2245	2
0683-2715	R:FXD COMP 270 OHM 5% 1/4W	01121	CB 2715	1
0683-3305	R:FXD COMP 33 OHM 5% 1/4W	01121	CB 3305	3
0683-3615	R:FXD COMP 360 OHM 5% 1/4W	01121	CB 3615	1
0683-3915	R:FXD COMP 390 OHM 5% 1/4W	01121	CB 3915	1
0683-4725	R:FXD COMP 4700 OHM 5% 1/4W	01121	CB 4725	2
0683-5115	R:FXD COMP 510 OHM 5% 1/4W	01121	CB 5115	1
0683-5625	R:FXD COMP 5600 OHM 5% 1/4W	01121	CB 5625	1
0683-6205	R:FXD COMP 62 OHM 5% 1/4W	01121	CB 6205	1
0683-6815	R:FXD COMP 680 OHM 5% 1/4W	01121	CB 6815	1
0683-7525	R:FXD COMP 7500 OHM 5% 1/4W	01121	CB 7525	1
0683-8205	R:FXD COMP 82 OHM 5% 1/4W	01121	CB 8205	1
0684-1041	R:FXD COMP 100K OHM 10% 1/4W	01121	CB 1041	1
0684-1511	R:FXD COMP 150 OHM 10% 1/4W	01121	CB 1511	1
0684-2701	R:FXD COMP 27 OHM 10% 1/4W	01121	CB 2701	1
0684-5621	R:FXD COMP 5600 OHM 10% 1/4W	01121	CB 5621	2
0686-2425	R:FXD COMP 2400 OHM 5% 1/2W	01121	EB 2425	1
1250-0102	CONNECTOR:BNC	91737	1250-0102	1
1251-0099	CONNECTOR:50-PIN MINIATURE	02660	57-10500	1
1251-0135	CONNECTOR:15-CONTACTS	95354	SD 615UR	1
1850-0091	TRANSISTOR:GERMANIUM PNP 2N2048	87216	2N2048	4
1900-0011	DIODE:SILICON 1N4168M MATCHED PAIR	93332	1N4168M	1
1901-0040	DIODE:SILICON	28480	1901-0040	3
1910-0016	DIODE:GERMANIUM 1 MICROSEC 60 WIV	28480	1910-0016	1
9140-0025	COIL:FXD RF 4.7 UH	28480	9140-0025	1
9140-0107	COIL:FXD RF 27 UH	28480	9140-0107	1
9140-0111	COIL:FXD RF 3.3 UH	28480	9140-0111	1
9140-0118	COIL:500 MH 5%	99800	2500-14	2
9140-0125	COIL:VAR 0.9-1.9 UH	28480	9140-0125	1
9140-0126	COIL:VAR 1.76-4.02 UH	28480	9140-0126	1
9140-0142	COIL:FXD RF 2.2 UH	28480	9140-0142	1
9170-0059	CORE:TOROID	02114	396T125-102	3

# See list of abbreviations in introduction to this section

# HEWLETT-PACKARD SALES AND SERVICE OFFICES in the United States and Canada

## ALABAMA

**Huntsville, 35802**  
2003 Byrd Spring Rd. S.W.  
(205) 881-4591  
TWX: 510-579-2204

## ALASKA

**Bellevue, Wash. 98004**  
11656 N.E. 8th Street  
(206) 454-3971  
TWX: 910-443-2303

## ARIZONA

**Scottsdale, 85251**  
3009 No. Scottsdale Rd.  
(602) 945-7601  
TWX: 602-949-0111

**Tucson, 85716**  
232 So. Tucson Blvd.  
(602) 623-2564  
TWX: 602-792-2759

## CALIFORNIA

**North Hollywood, 91604**  
3939 Lankershim Blvd.  
(213) 877-1282 and 766-3811  
TWX: 910-499-2170

**Sacramento, 95821**  
2591 Carlsbad Ave.  
(916) 482-1463  
TWX: 916-444-8683

**San Diego, 92106**  
1055 Shafter Street  
(714) 223-8103  
TWX: 714-276-4263

**Palo Alto, 94303**  
1101 Embarcadero Rd.  
(415) 327-6500  
TWX: 910-373-1280

## COLORADO

**Englewood, 80110**  
7955 East Prentice  
(303) 771-3455  
TWX: 303-771-3056

## CONNECTICUT

**Middletown, 06458**  
589 Saybrook Rd.  
(203) 346-6611  
TWX: 710-428-2036

## FLORIDA

**Miami, 33125**  
2907 Northwest 7th St.  
(305) 635-6461

**Orlando, 32803**  
621 Commonwealth Ave.  
(305) 425-5541  
TWX: 305-275-1234

**St. Petersburg, 33708**  
410-150th Ave., Madeira Beach  
(813) 391-0211  
TWX: 813-391-0666

## GEORGIA

**Atlanta, 30305**  
3110 Maple Drive, N.E.  
(404) 233-1141  
TWX: 810-751-3283

## HAWAII

**North Hollywood, Calif. 91604**  
3939 Lankershim Blvd.  
(213) 877-1282 and 766-3811  
TWX: 910-499-2170

## ILLINOIS

**Skokie, 60078**  
5500 Howard Street  
(312) 677-0400  
TWX: 910-223-3613

## INDIANA

**Indianapolis, 46205**  
3919 Meadows Dr.  
(317) 546-4891  
TWX: 317-635-4300

## LOUISIANA

**New Orleans**  
(504) 522-4359

## MARYLAND

**Baltimore, 21207**  
6660 Security Blvd.  
(301) 944-5400

**Rockville, 20852**  
12303 Twinbrook Pkwy.  
(301) 427-7560  
TWX: 710-828-9684

## MASSACHUSETTS

**Burlington, 01804**  
Middlesex Turnpike  
(617) 272-9000  
TWX: 710-332-0382

## MICHIGAN

**Southfield, 48076**  
24315 Northwestern Hwy.  
(313) 353-9100  
TWX: 313-357-4425

## MINNESOTA

**St. Paul, 55114**  
2459 University Ave.  
(612) 646-7881  
TWX: 910-563-3734

## MISSOURI

**Kansas City, 64131**  
7916 Paseo Street  
(816) 444-9494  
TWX: 816-556-2423

**St. Louis, 63144**  
2814 South Brentwood Blvd.  
(314) 647-4350  
TWX: 314-962-3933

## NEW JERSEY

**Eatontown**  
(201) 542-0852  
**Englewood, 07631**  
391 Grand Avenue  
(201) 567-3933

## NEW MEXICO

**Albuquerque, 87108**  
6501 Lomas Blvd., N.E.  
(505) 255-5586  
TWX: 910-989-1655

**Las Cruces, 88001**  
114 S. Water Street  
(505) 526-2486  
TWX: 505-524-2671

## NEW YORK

**New York, 10021**  
236 East 75th Street  
(212) 879-2023  
TWX: 710-581-4376

**Rochester, 14623**  
39 Saginaw Drive  
(716) 473-9500  
TWX: 510-253-5981

**Poughkeepsie, 12601**  
82 Washington Street  
(914) 454-7330  
TWX: 914-452-7425

**Syracuse, 13211**  
5858 East Molloy Rd.  
(315) 454-2486  
TWX: 710-541-0482

**Endicott, 13764**  
1219 Campville Rd.  
(607) 754-0050  
TWX: 510-252-0890

## NORTH CAROLINA

**High Point, 27262**  
1923 N. Main Street  
(919) 882-6873  
TWX: 510-926-1516

## OHIO

**Cleveland, 44129**  
5579 Pearl Road  
(216) 884-9209  
TWX: 216-888-0715

**Dayton, 45409**  
1250 W. Dorothy Lane  
(513) 298-0351  
TWX: 513-944-0090

## OKLAHOMA

**Oklahoma City**  
(405) 235-7062

## PENNSYLVANIA

**Camp Hill**  
(717) 737-6791  
**West Conshohocken, 19428**  
144 Elizabeth Street  
(215) 248-1600 and 828-6200  
TWX: 215-828-3847

**Monroeville, 15146**  
2814 Moss Side Blvd.  
(412) 271-5227  
TWX: 710-797-3650

## TEXAS

**Dallas, 75209**  
P.O. Box 7166, 3605 Inwood Rd.  
(214) 357-1881 and 332-6667  
TWX: 910-861-4081

**Houston, 77027**  
P.O. Box 22813, 4242 Richmond Ave  
(713) 667-2407  
TWX: 713-571-1353

## UTAH

**Salt Lake City, 84115**  
1482 Major St.  
(801) 486-8166  
TWX: 801-521-2604

## VIRGINIA

**Richmond, 23230**  
2112 Spencer Road  
(703) 282-5451  
TWX: 710-956-0157

## WASHINGTON

**Bellevue, 98004**  
11656 N. E. 8th St.  
(206) 454-3971  
TWX: 910-443-2303

## GOVERNMENT CONTRACTING OFFICES

**Middletown, Pa. 17057**  
Hewlett-Packard  
Contract Marketing Division  
Olmsted Plaza  
(717) 944-7401  
TWX: 717-760-4816

**West Conshohocken, Pa. 19428**  
Hewlett-Packard  
Contract Marketing Division  
144 Elizabeth Street  
(215) 753-1811  
TWX: 215-820-3847

## CANADA

**Montreal, Quebec**  
Hewlett-Packard (Canada) Ltd.  
8270 Mayrand Street  
(514) 735-2273  
TWX: 610-421-3484

**Ottawa, Ontario**  
Hewlett-Packard (Canada) Ltd.  
1762 Carling Avenue  
(613) 722-4223  
TWX: 610-562-1952

**Toronto, Ontario**  
Hewlett-Packard (Canada) Ltd.  
1415 Lawrence Avenue West  
(416) 249-9196  
TWX: 610-492-2382

**Vancouver, B.C.**  
Hewlett-Packard (Canada) Ltd.  
2184 W. Broadway  
(604) 738-7520  
TWX: 610-922-5059



# HEWLETT-PACKARD INTERNATIONAL OFFICES

## Electronic Instrument Sales and Service

### ARGENTINA

Mauricio A. Saurez  
Telecomunicaciones  
Carlos Calvo 224, Buenos Aires  
Tel: 30-6312

### AUSTRALIA

Sample Electronics (Vic.) Pty. Ltd.  
9-11 Cremorne Street  
Richmond E. 1, Victoria  
Tel: 42-4757 (3 lines)  
Sample Electronics (N.S.W.) Pty. Ltd.  
4 Grose Street, Glebe, N.S.W.  
Tel: 69-6338 (6 lines)

### AUSTRIA

UNILABOR H.m.b.H.  
Wissenschaftliche Instrumente  
Rummelhardtgasse 6/3  
P.O. Box 33, Vienna IX/71  
Tel: 42 61 81

### BELGIUM

Hewlett-Packard Benelux  
20-24 Rue de l'Hopital, Brussels 1  
Tel: 11.22.20

### BRAZIL

Ciental Importacao e Comercio Ltda.  
R. Des Eliseu Guilherme, 62  
Sao Paulo 6  
Tel: 32-4332

### CHILE

Hector Calcagni  
Casilla 13942, Santiago  
Tel: 6.42.26

### COLOMBIA

Instrumentacion Henrik A. Langebeck  
& Cia. Ltda.  
Apartado Aereo 6287  
Bogota 1, D.E.  
Tel: 45-78-06  
Cable: AARIS - Bogota

### DENMARK

Tage Olsen A/S  
Ronnegade 1, Copenhagen 0  
Tel: 29.48.00

### FINLAND

INTO O/Y  
P.O. Box 153  
11 Meritulinkatu, Helsinki  
Tel: 6.11.33

### FRANCE

Hewlett-Packard France  
150 Blvd. Massena, Paris 13e  
Tel: 707.97.19

### GERMANY

Hewlett-Packard VgmbH  
Steindamm 35, Hamburg 1  
Tel: 24.05.51

Hewlett-Packard VgmbH  
Kurhessenstrasse 95  
Frankfurt a. Main  
Tel: 52.00.36

Hewlett-Packard VgmbH  
Reginfriedstrasse 13  
Munich 9  
Tel: 49.51.21/2

Hewlett-Packard VgmbH  
Technisches Buro  
Herrenbergerstrasse 110  
703 Boblingen, Wurttemberg  
Tel: 6971

Hewlett-Packard VgmbH  
Lietzenburger Strasse 30  
1000 Berlin 30  
Tel: 24 92 71

### GREECE

K. Karayannis  
Klaffmonos Square, Athens 124  
Tel: 230.301

### INDIA

The Scientific Instrument Company, Ld.  
6, Tej Bahadur Sapru Road, Allahabad 1  
Tel: 2451

The Scientific Instrument Company, Ld.  
240, Dr. Dadabhai Naoroji Rd., Bombay 1  
Tel: 26-2642

The Scientific Instrument Company, Ld.  
11, Esplanade East, Calcutta 1  
Tel: 23-4129

The Scientific Instrument Company, Ld.  
30, Mount Road, Madras 2  
Tel: 86339

The Scientific Instrument Company, Ld.  
B-7, Ajmeri Gate Extn., New Delhi 1  
Tel: 271053

### IRAN

Telecom Ltd.  
P.O. Box 1812, Tehran  
Tel: 43850

### ISRAEL

Electronics & Engineering Ltd.  
16 Kremenetski St., Tel Aviv  
Tel: 35021-23

### ITALY

Hewlett-Packard Italiana S.p.A.  
Viale Lunigiana 46, Milan  
Tel: 69.15.84/5/6

Hewlett-Packard Italiana S.p.A.  
Palazzo Italia  
Piazza Marconi, 25, Roma-Eur  
Tel: 59.12.544/5

### JAPAN

Yokogawa-Hewlett-Packard Ltd.  
2270 Ishikawa-cho  
Hachioji, Tokyo  
Tel: Hachioji 0426-3-1231 (19 lines)

Yokogawa-Hewlett-Packard Ltd.  
No. 3, 6-chome, Aoyama-Kitamachi  
Akasaka, Minato-ku, Tokyo  
Tel: 403-6511

Yokogawa-Hewlett-Packard Ltd.  
No. 8, Umeda, Kita-ku, Osaka  
Tel: 313-0091

Yokogawa-Hewlett-Packard Ltd.  
No. 4, 3-chome, Himeikedori,  
Chigusa-ku, Nagoya  
Tel: 751-8545

### KOREA

American Trading Company, Korea, Ltd.  
112-35 Sokong-Dong, Jung-ku  
Seoul P.O. Box 1103, Seoul  
Tel: 3-7049, 3-7613

### NETHERLANDS

Hewlett-Packard Benelux N.V.  
23 Burg Roelstraat, Amsterdam W.  
Tel: (020) 13.28.98 and 13.54.99

### NEW ZEALAND

Sample Electronics (N. Z.) Ltd.  
8 Matipo Street  
Onehunga S. E. 5, Auckland  
Tel: 555-361

### NORWAY

Morgenstjerne & Co. A/S  
Ingenjorfirma  
6 Wessels Gate, Oslo  
Tel: 20 16 35

### PANAMA

Electronico Balboa, S.A.  
P.O. Box 4929  
Panama City 5, Panama  
Tel: 3-0833

### PERU

Fernando Ezeta B.  
Casilla 3061  
Lima  
Tel: 78745

### PORTUGAL

TELECTRA  
Rua Rodrigo da Fonseca 103  
P.O. Box 2531, Lisbon 1  
Tel: 68 60 72 and 68 60 73 and 68 60 74

### PUERTO RICO & VIRGIN ISLANDS

San Juan Electronics, Inc.  
150 Ponce de Leon, Stop 3  
P.O. Box 5167  
Pta. de Tierra Sta., San Juan 00906  
Tel: 725-3342, 724-4406

### SPAIN

ATAIO, Ingenieros  
Enrique Larreta 12, Madrid 6  
Tel: 235.43.44 and 235.43.45

### SOUTH AFRICA

F. H. Flanter & Co. (Pty.), Ltd.  
Rosella House  
Buitencingle Street, Cape Town  
Tel: 3-3817

### SWEDEN

H-P Instrument AB  
Centralvagen 28, Solna, Centrum  
Tel: 83.08.30

H-P Instrument AB  
Idunagatan 28A  
Goteborg  
Tel: 27 68 00 and 27 68 01

### SWITZERLAND

Max Paul Frey  
Wankdorffeldstrasse 66, Berne  
Tel: (031) 42.00.78

### TAIWAN (FORMOSA)

Hwa Sheng Electronic Co., Ltd.  
21 Nanking West Road, Taipei  
Tel: 4 6076, 4 5936

### TURKEY

TELEKOM Engineering Bureau  
P.O. Box 376—Galata, Istanbul  
Tel: 49.40.40

### UNITED KINGDOM

Hewlett-Packard Ltd.  
Dallas Rd., Bedford, England  
Tel: Bedford 68052

### VENEZUELA

Citec, C. A.  
Edif. Arisan-Of #4  
Avda. Francisco de Miranda-Chacaito  
Apartado del Este 10.837, Caracas  
Tel: 71.88.05

### YUGOSLAVIA

Belram S.A.  
83 Avenue des Mimosas  
Brussels 15, Belgium  
Tel: 35.29.58

For Sales and Service Assistance in Areas Not Listed Contact:

### IN EUROPE

Hewlett-Packard, S. A.  
54 Route des Acacias  
Geneva, Switzerland  
Telephone: (022) 42.81.50  
Telex: 2.24.86  
Cable: HEWPACKSA

### IN LATIN AMERICA

Hewlett-Packard Inter-Americas  
1501 Page Mill Road  
Palo Alto, California 94304, U.S.A.  
Telephone: (415) 326-7000  
TWX: 910-373-1267  
Telex: 033811 Cable: HEWPACK

### ELSEWHERE

Hewlett-Packard  
Overseas Sales Department  
1501 Page Mill Road  
Palo Alto, California 94304, U.S.A.  
Telephone: (415) 326-7000  
TWX: 910-373-1267  
Telex: 033811 Cable: HEWPACK



## Free Manuals Download Website

<http://myh66.com>

<http://usermanuals.us>

<http://www.somanuals.com>

<http://www.4manuals.cc>

<http://www.manual-lib.com>

<http://www.404manual.com>

<http://www.luxmanual.com>

<http://aubethermostatmanual.com>

Golf course search by state

<http://golfingnear.com>

Email search by domain

<http://emailbydomain.com>

Auto manuals search

<http://auto.somanuals.com>

TV manuals search

<http://tv.somanuals.com>