

Color 
LaserJet™

*8550, 8550N, 8550DN, 8550GN,
8550MFP Printer*

Getting Started Guide

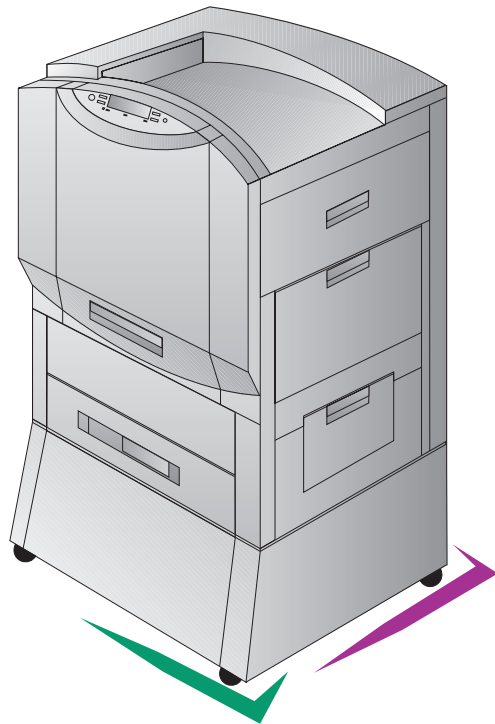

English

HP Color LaserJet 8550, 8550N,
8550DN, 8550GN, 8550MFP
Printer

Getting Started Guide

Copyright Information

©2000 Hewlett-Packard
Company

All Rights Reserved.

Reproduction, adaptation, or translation without prior written permission is prohibited, except as allowed under the copyright laws.

Part number: C7096-90923

First Edition: April, 2000

Warranty

The information contained in this document is subject to change without notice.

Hewlett-Packard makes no warranty of any kind with respect to this information.

HEWLETT-PACKARD
SPECIFICALLY DISCLAIMS
THE IMPLIED WARRANTY OF
MERCHANTABILITY AND
FITNESS FOR A PARTICULAR
PURPOSE.

Hewlett-Packard shall not be liable for any direct, indirect, incidental, consequential, or other damage alleged in connection with the furnishing or use of this information.

Trademark Credits

Adobe™ is a trademark of Adobe Systems Incorporated which may be registered in certain jurisdictions.

CompuServe™ is a U.S. trademark of CompuServe, Inc.

HP-UX 9.* and 10.0 for HP 9000 Series 700 and 800 computers are X/Open Company UNIX 93 branded products.

Microsoft®, *Windows®*, *Windows NT®*, and *MS-DOS®* are U.S. registered trademarks of Microsoft Corporation.

PostScript™ is a trademark of Adobe Systems Incorporated which may be registered in certain jurisdictions.

UNIX® is a registered trademark in the United States and other countries, licensed exclusively through X/Open Company Limited.

All other products mentioned herein may be trademarks of their respective companies.

Contents

Printer Information	2
Configurations	2
Step 1: Preparing a Location for the Printer	4
Step 2: Unpacking the Printer	5
Step 3: Installing the Cables	10
Step 4: Connecting the Printer to the Network	14
Step 5: Changing the Printer Control Panel Overlay and Language (Optional)	16
Selecting the Display Language	17
Step 6: Installing the Consumables	18
Step 7: Loading the Input Trays	25
Step 8: Configuring Input Trays	31
Tray 1 Auto	31
Configuring Media Type and Size	32
Step 9: Printing a Configuration Page	33
Communicating with an optional HP JetDirect internal print server	35
Step 10: Understanding the Software	37
Structure of the CD-ROMs	37
Installing the Software	38
Accessing the Online User Guide	39
Additional Information	40
Step 11: Windows Network Installation	41
Configuring the Printer on the Network	43
Distributing the Printer Software to Network Clients	43
Installing the Printer Software for Network Clients	44
Connecting Network Clients to the Printer	45
Step 12: IBM LAN Network Installation	48
Distributing the Printer Software to Network Clients	48
Installing the Printer Software for Network Clients	48
Connecting Network Clients to the Printer	49
Step 13: Macintosh Network Installation	50
Installing the Macintosh Printer Software	50
Connecting Network Clients to the Printer	51
Configuring the Printer on the Network	52
Distributing the Printer Software to Network Clients	53
Installing the Macintosh Printer Software for Network Clients	53
Troubleshooting Checklist	54

Printer Information

Configurations

This printer is available in five configurations, as described below:



HP Color LaserJet 8550

The HP Color LaserJet 8550 comes standard with a 100-sheet tray 1, a 500-sheet tray 3, a printer stand, and 32 MB RAM.



HP Color LaserJet 8550N

The HP Color LaserJet 8550N comes standard with a 100-sheet tray 1, a 500-sheet tray 2, a 500-sheet tray 3, a printer stand, 32 MB RAM, an HP JetDirect print server (10/100 Base-TX), and an internal hard disk.

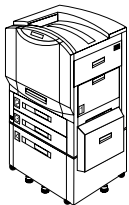

HP Color LaserJet 8550DN

The HP Color LaserJet 8550DN comes standard with a 100-sheet tray 1, a 500-sheet tray 2, a 500-sheet tray 3, a (tray 4) 2,000-sheet input tray, a duplexer, 64 MB RAM, an HP JetDirect print server (10/100 Base-TX), an internal hard disk, and five stabilizing legs.



HP Color LaserJet 8550GN

The HP Color LaserJet 8550GN comes standard with a 100-sheet tray 1, a 500-sheet tray 2, a 500-sheet tray 3, a (tray 4) 2,000-sheet input tray, a duplexer, 128 MB RAM, an HP JetDirect print server (10/100 Base-TX), an internal hard disk, five stabilizing legs, and a higher performance processor.

HP Color LaserJet 8550MFP



The HP Color LaserJet 8550MFP comes standard with a 100-sheet tray 1, a 500-sheet tray 2, a 500-sheet tray 3, a duplexer, 64 MB RAM, an HP JetDirect print server (10/100 Base-TX), an internal hard disk, a printer/copy module stand, and a copy module.

Step 1: Preparing a Location for the Printer

Figure 1

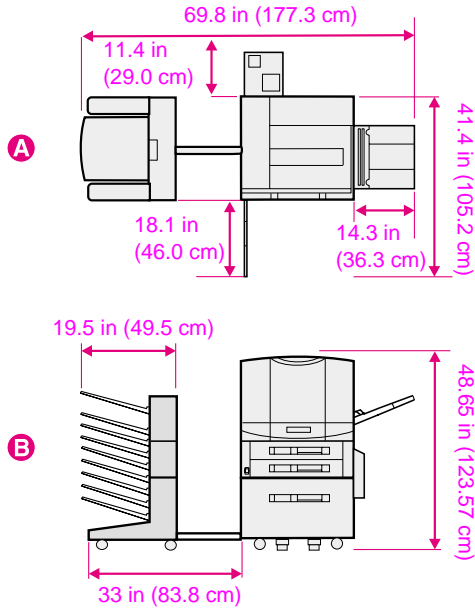

- A** Top View (with optional multi-bin mailbox and tray 4)
- B** Front View (with optional multi-bin mailbox and tray 4)

This printer requires the following:

- Space around the printer, as shown above
- Sturdy, level floor surface
- A well-ventilated room without abrupt humidity or temperature changes
- An area with a recommended temperature range of 68° to 79° F (20° to 26° C), or an allowed temperature range of 59° to 86° F (15° to 30° C)
- An area with a recommended humidity range of 20% to 50% relative humidity (RH), or an allowed humidity range of 10% to 80% RH
- Line voltage and frequency not varying more than 10% from the value stated on the printer regulatory label (located on the back of the printer)

Step 2: Unpacking the Printer

CAUTION

Do not plug the printer into a power source until all shipping material is removed. This may cause damage to the printer.

Figure 2

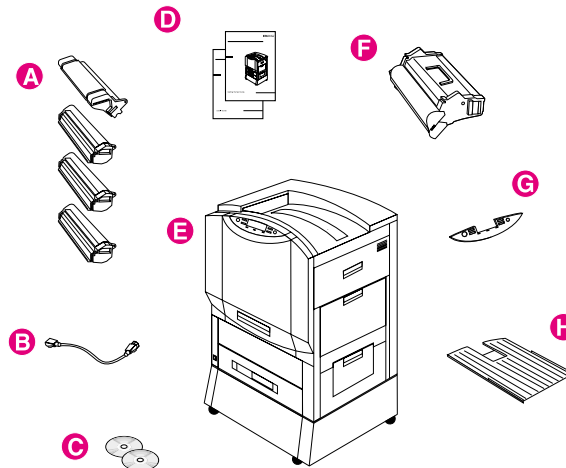

The following items are included with the printer:

- A** Toner cartridges: black, cyan, magenta, and yellow
- B** Power cord
- C** Software on CD-ROM
- D** Manuals: getting started guide (this guide) and quick reference guide; the online user guide is on a CD-ROM
- E** Printer—shown with standard printer stand; some printer models include a 2,000-sheet input tray (tray 4) that replaces the printer stand; a tray 2 is also included with some printer models
- F** Imaging drum
- G** Control panel overlay (if applicable)
- H** Left (face-up) output bin

Note

If the printer model you ordered includes a 2,000-sheet input tray (tray 4), a power pack (containing power connections for the printer and tray 4), a preinstalled interface cable (connecting tray 4 to the printer), and five stabilizing legs are also included.

To unpack the printer

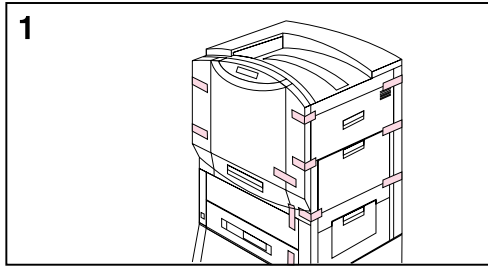

- 1 Remove all external packing tape from the printer.
- 2 Open the lower left door and push down the green lever on the right side of the fuser. Then, remove the orange shipping notice from the fuser.
- 3 Open the front door.

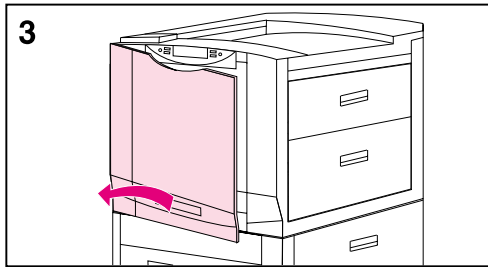
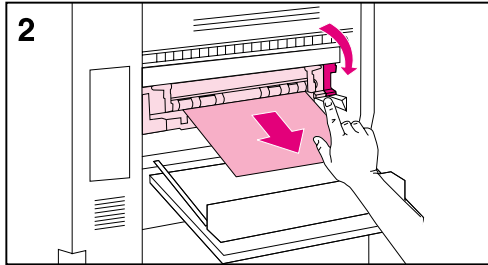

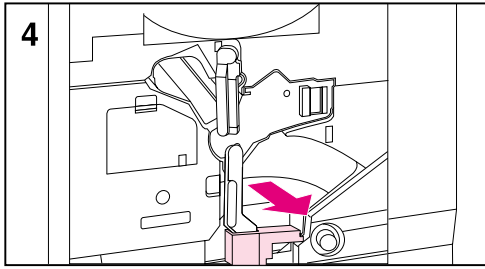

4 Remove the orange packing material from the lower (green) lever.

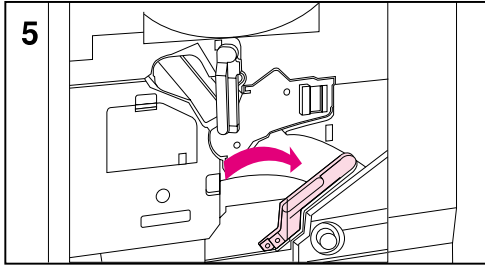

5 Press the white button on the lower (green) lever and swing the lever to the right.

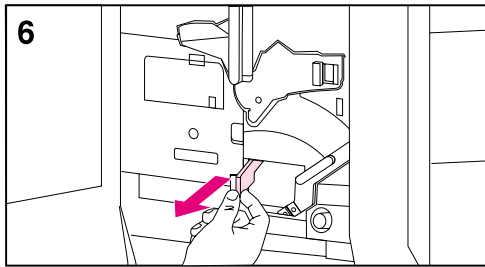

6 Remove the packing material from inside the printer and then swing the lower (green) lever back to the left, making sure the lever clicks into place.

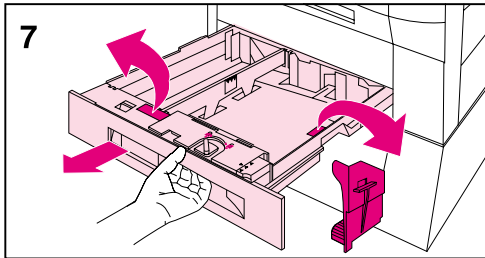

7 Firmly grip the handle in the center of tray 3, squeeze the release lever, and pull the tray out until it stops. Then remove the orange packing spacers from inside the tray and close the tray.

8 If the printer comes with a tray 2, repeat step 7 to remove the orange packing spacers from tray 2

If the printer came with a tray 4, continue with step 9. If the printer came with a stand, proceed to step 16.

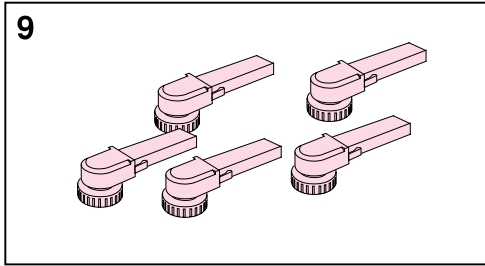

Note

Follow steps 9-12 to attach the five stabilizing legs to the bottom of tray 4. If the five stabilizing legs (which are in addition to the four locking wheels) are already attached, proceed to step 13.

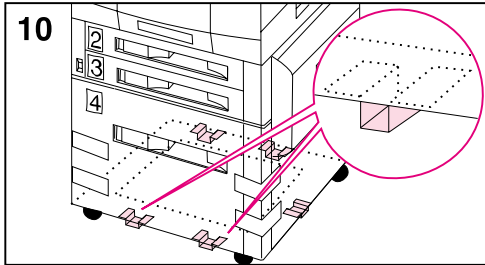

9 Locate the five stabilizing legs that came with the printer.

10 Locate the five guides for the stabilizing legs on the bottom of tray 4—two guides at the front edge, one on the right edge, and two on the back edge.

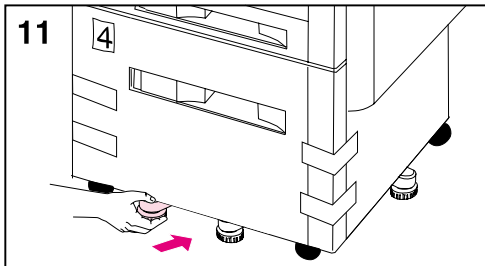

11 Insert a stabilizing leg into one of the guides and push the leg into the guide until it stops.

12 Repeat step 11 above to attach the other four stabilizing legs.

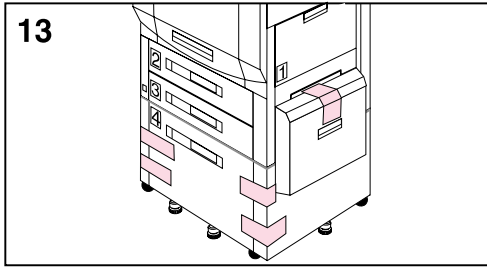

13 Remove the packing tape from tray 4.

14 Firmly grip the handle in the center of tray 4, squeeze the release lever, and pull the tray out until it stops.

15 Remove the two orange packing clips from inside tray 4 by squeezing the sides of the clips and pulling them out.

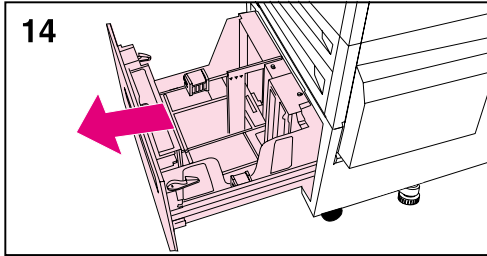

CAUTION

Leaving the orange clips in tray 4 can damage the tray.

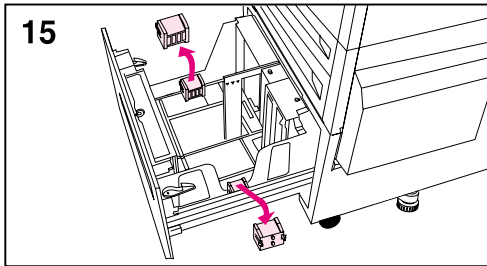

16 Close all doors and input trays.

By completing steps 1 through 16 above, all tape and spacers should be removed and unpacking of the printer should be complete.

Step 3: Installing the Cables

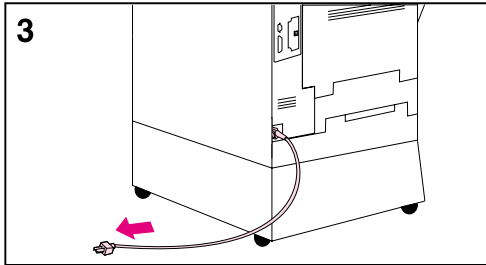
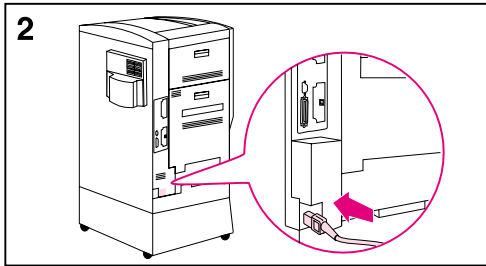
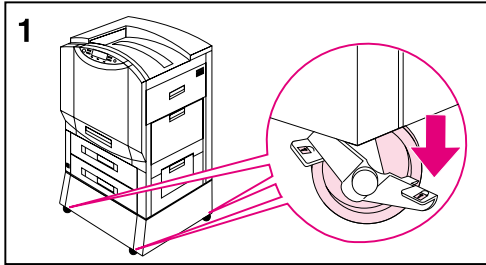

To connect the power cord to a printer with a stand

Note

Make sure that the printer is off (power button out) before connecting the power cord.

- 1 Roll the printer to its permanent location, where all four wheels rest on a level floor surface, and stabilize it by pushing the locking tabs on the printer stand's wheels to the locked position.

WARNING!

An unstable printer can tip over and cause injury; make sure that the printer is secured properly.

- 2 Plug the female end of the power cord into the connector on the back left corner of the printer.
- 3 Plug the male end of the power cord into a surge protector or other grounded power source.

To connect the interface cable and power cords for a printer with an optional tray 4

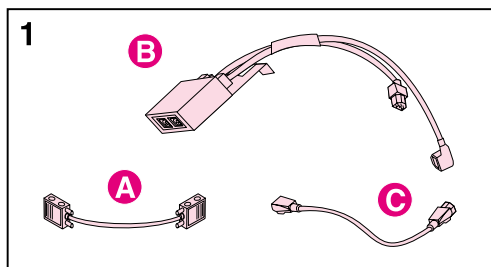

Note

Make sure that the printer is off (power button out) before attaching the interface cable and connecting the power cords.

- 1 Locate the interface cable (A), the power pack (B), and the straight power cord (C).

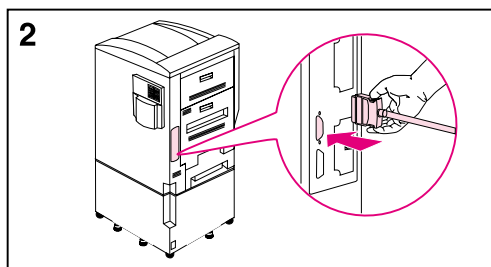

Note

The interface cable (A) might already be attached to the printer and tray 4. If it is, proceed to step 4 below; otherwise, continue with step 2.

- 2 Attach the end of the interface cable that is marked with one dot to the printer above the parallel connector.

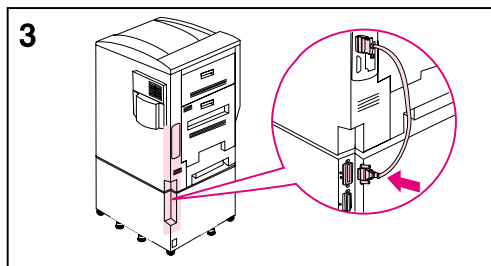

- 3 Attach the other end of the interface cable (marked with two dots) to the connector on tray 4 that is marked with two dots.

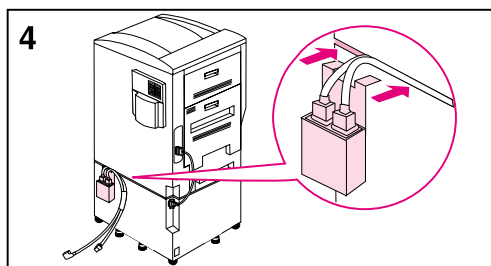

- 4 Attach the power pack to the back of the printer by inserting the clip into the space between the printer and tray 4.

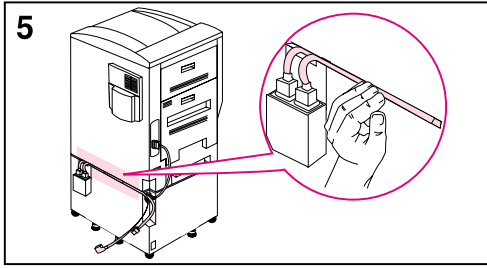

5 Push the two cables extending from the power pack into the space between the printer and tray 4 along the back of the printer.

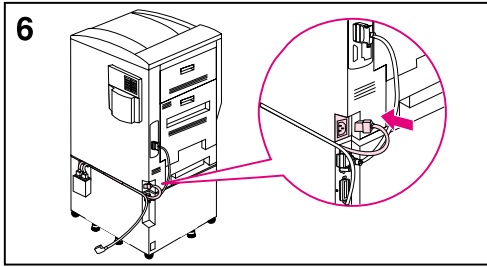

6 Plug the shorter of the two cables into the connector on the back left corner of the printer.

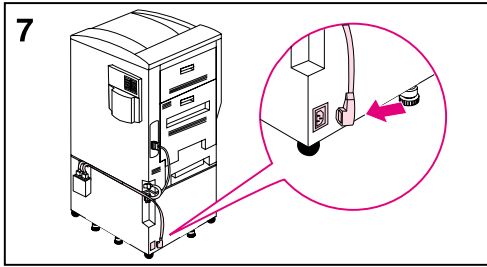

7 Plug the longer of the two cables into the connector on the back left corner of tray 4.

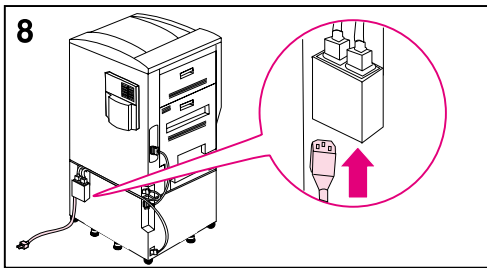

8 Plug the female end of the power cord into the male connector on the bottom of the power pack.

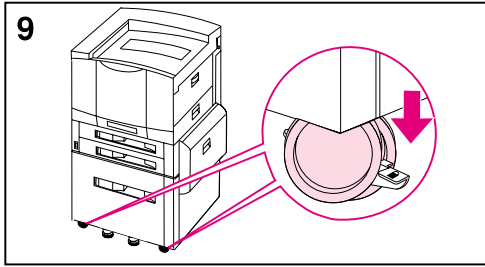

9 Roll the printer to its permanent location, where all four wheels rest on a level floor surface, and stabilize it by pushing the locking tabs on the tray's wheels to the locked position.

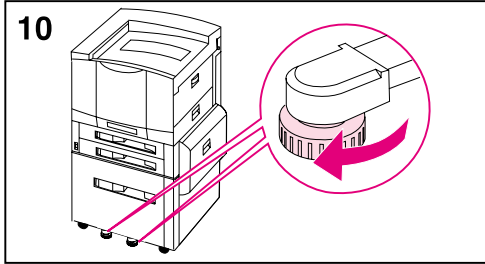

10 Rotate the feet of the five stabilizing legs and the anti-tip foot (on the left side of the tray) until they are snug against the floor.

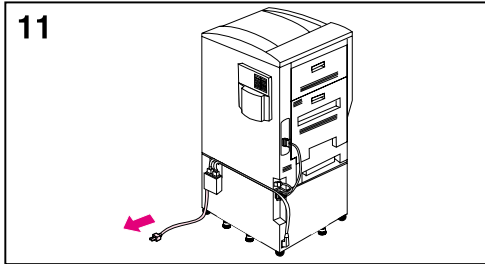

11 Plug the male end of the power cord into a surge protector or other grounded power source.

WARNING!

An unstable printer can tip over and cause injury; make sure that the printer is secured properly.

Note

If an optional output device was ordered, see the installation guide included with the output device for installation instructions.

Step 4: Connecting the Printer to the Network

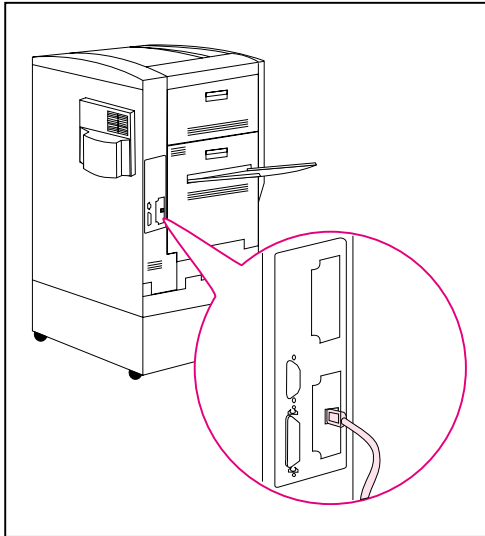

If you will connect the computer to the printer with a parallel cable, see “To connect a parallel cable” later in this Step.

If the printer was shipped with an optional HP JetDirect 10/100TX internal print server for 10Base-T or 100Base-TX networks, the RJ-45 (unshielded twisted pair) card is installed.

To connect to a 10Base-T or 100Base-TX network

Plug the connector of the unshielded twisted-pair network cable into the RJ-45 port. The other end of the cable should be attached to the network.

Note

The RJ-45 cable is not included with the printer. It must be purchased separately.

To connect a parallel cable

To print through the parallel port, the printer requires a 25-pin male/micro 36-pin male ("C-size") parallel cable that is IEEE-1284 compliant. The cable is not included with the printer. It must be purchased separately.

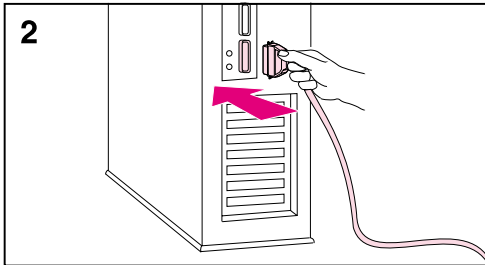
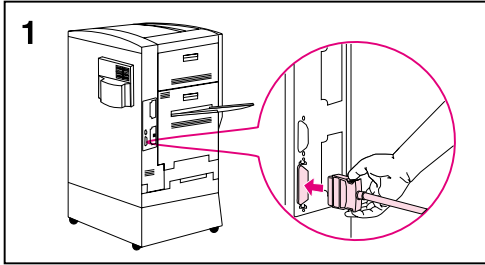

- 1 Squeeze the clips on the micro 36-pin end of the parallel cable and plug it into the printer's parallel port. Release the clips.
- 2 Plug the other end of the parallel cable into the computer. Tighten the screws on the parallel cable to secure the cable to the computer.

Step 5: Changing the Printer Control Panel Overlay and Language (Optional)

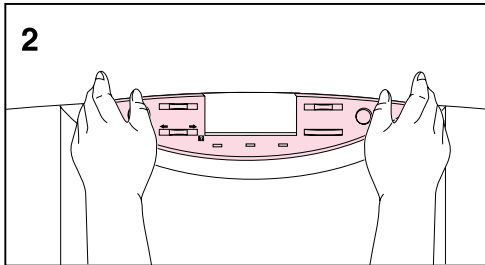
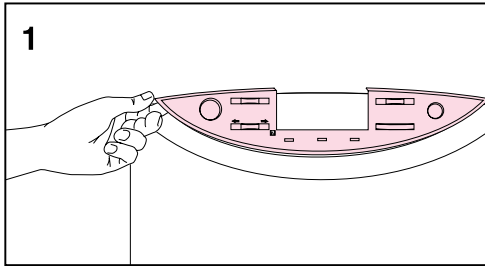

Replace the printer control panel overlay with the one included for your language, if applicable. Then configure the printer control panel to show printer messages in your language.

To replace the overlay

- 1 Insert a thumbnail or a thin, rigid object under the edge of the overlay on the printer control panel and pull up on the overlay until it comes off.
- 2 Place the new overlay over the printer control panel and snap it into place.

Selecting the Display Language

Use the printer control panel to set the printer to display printer messages and print configuration pages in a variety of supported languages.

To select the printer control panel language

Figure 3

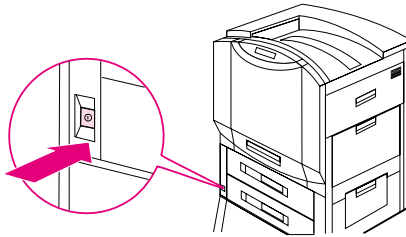

- 1 Hold down **SELECT** while turning the printer on (power button in). **SELECT LANGUAGE** (in English) appears on the printer control panel display for approximately one second. Once the printer has restarted, **LANGUAGE = ENGLISH** will appear on the display.

Note

Only **-VALUE+**, **SELECT**, and **Go** are active while the display language is being configured. All other keys are ignored.

If you press **Go** without selecting a language, the printer will bring itself online and all subsequent messages will be displayed in English. However, since no display language was selected, the **LANGUAGE = ENGLISH** message will reappear (after the power-on self test) when the printer is next turned on. This message will be displayed every time the printer is turned on until you select a language through the configure language mode.

- 2 Press **-VALUE+** until the language you want appears on the display.
- 3 Press **SELECT** to save the selection.
An asterisk (*) appears to the right of the selection. The language selected will be the default language until another selection is made by restarting the printer in the configure language mode.
- 4 Press **Go**.
- 5 Turn the printer off (power button out).

Step 6: Installing the Consumables

Figure 4

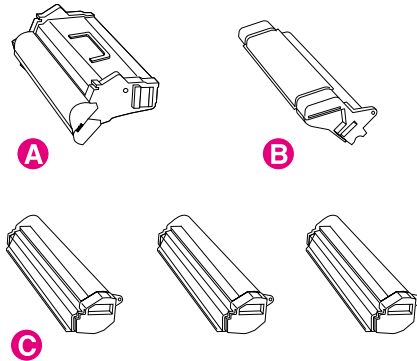

The following parts (consumables) are included with the printer:

- A** Imaging Drum
- B** Black Toner Cartridge
- C** Color Toner Cartridges: yellow, magenta, and cyan

Figure 5

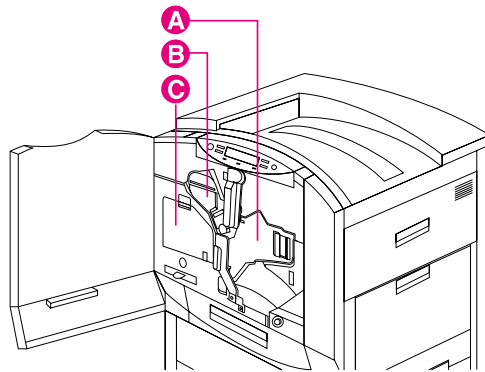

Install the consumables in the printer in this order:

- A** Imaging Drum
- B** Black Toner Cartridge
- C** Color Toner Cartridges (behind the clear door are three slots, one for each of the color toner cartridges)

To install the imaging drum

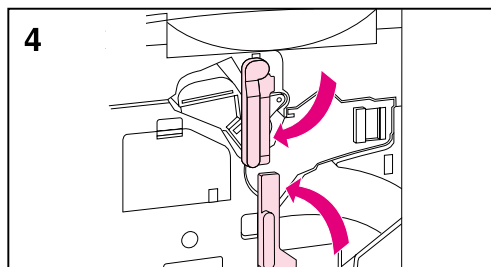
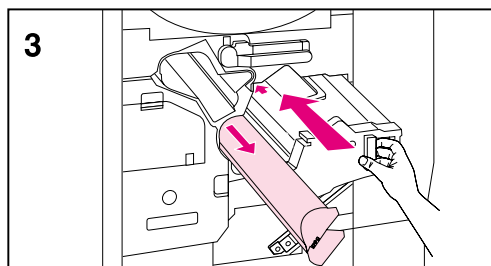
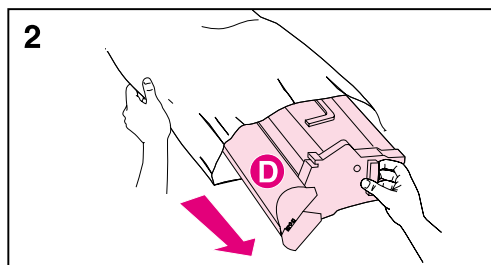
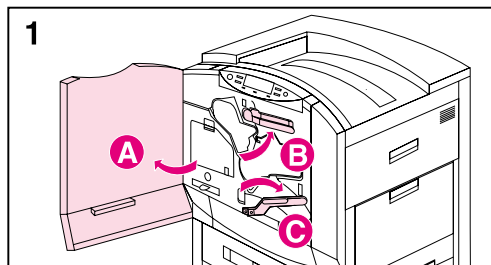

CAUTION

To prevent damage to the printer, do not move the printer after the imaging drum or any of the toner cartridges have been installed.

- 1 Leave the printer powered on and open the front door of the printer (A). Swing the upper (blue) lever to the right (B). Press the white button on the lower (green) lever and swing the lever to the right (C).
- 2 Remove the imaging drum from its packaging.

CAUTION

A gray cover (D) protects the drum's cylinder. Do not remove this cover; it will come off when you perform step 3, below.

- 3 Line up the guides and push firmly to slide the new drum into the printer. The cylinder's cover will slide off as the drum enters the printer. Set the cover aside.
- 4 Swing the upper (blue) lever to the left. Then swing the lower (green) lever back to the left, making sure it clicks into place.

Note

If the lever does not return to its original position, make sure that the imaging drum is all the way in the printer.

To install the black toner cartridge

- 1 Remove the black toner cartridge from its packaging.
- 2 Hold the cartridge with both hands and gently rock it several times to distribute the toner.

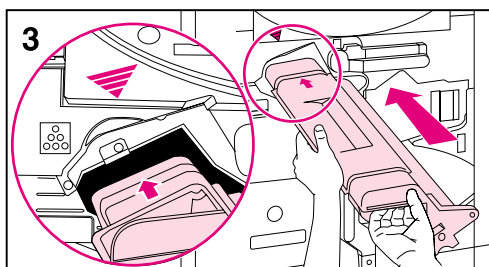
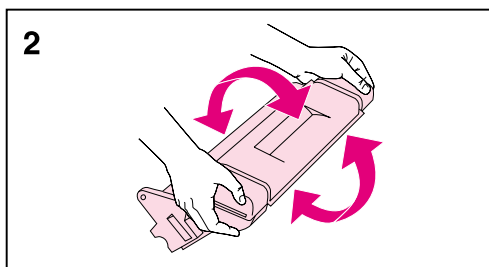
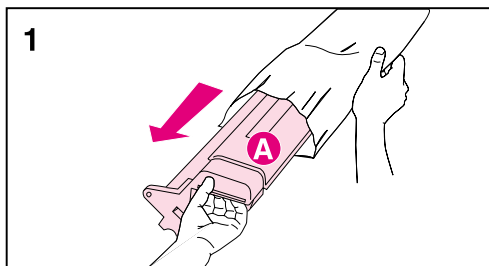

Note

Do not shake or rock the cartridge if the orange ring has been removed.

CAUTION

Do not lift or remove the shutter (A) on the cartridge.

- 3 Align the arrow on the top of the cartridge with the arrow at the top of the opening and slide the cartridge into the printer.

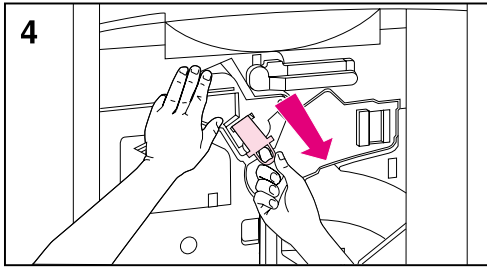

- 4 Place one hand on the cartridge and use the other hand to pull the orange ring and remove the seal. Set the seal aside.

Note

If toner gets on fabric, wipe the toner off with a dry cloth and then wash the clothing in cold water. Warm water or the heat of a dryer will set toner into fabric.

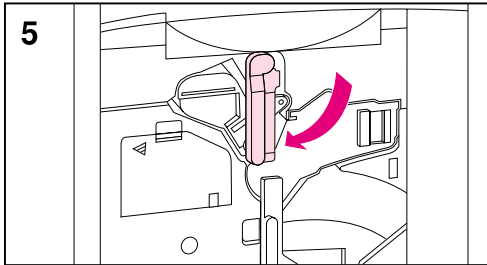

- 5 Swing the upper (blue) lever to the left.

Note

If the lever does not return to the left, make sure the cartridge is all the way in the printer and the orange seal was removed.

Note

Reset the toner levels when you replace the toner cartridges. See the user guide for more information on resetting the toner levels.

To install the color toner cartridges

- 1 Turn the printer on (power button in).
- 2 Press the blue button below the clear door to turn the color toner carousel to the slot marked with a yellow sticker.

Note

The carousel will not rotate unless the clear door is closed, the imaging drum and black toner cartridge are installed completely (including removing the orange seal from the black toner cartridge and swinging the upper lever to the left), and the upper right door is closed.

If the clear door is opened while the carousel is rotating, a printer error will occur. Turn the printer off and then turn the printer on to clear the error message from the control panel display.

- 3 Open the clear door.
- 4 Swing the blue lever next to the toner cartridge all the way to the right.

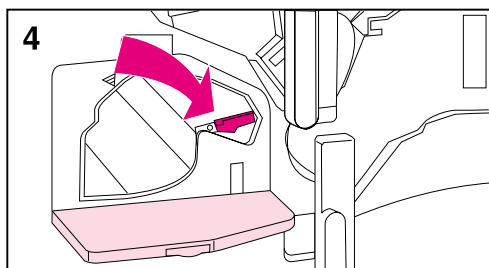
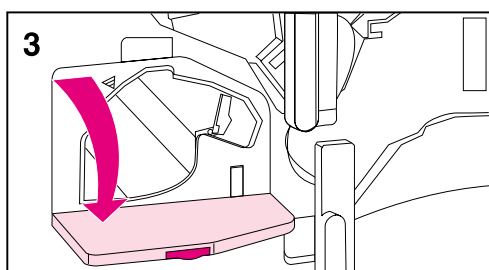
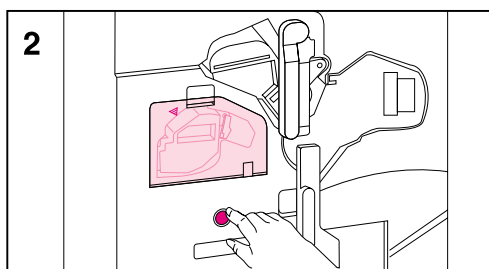
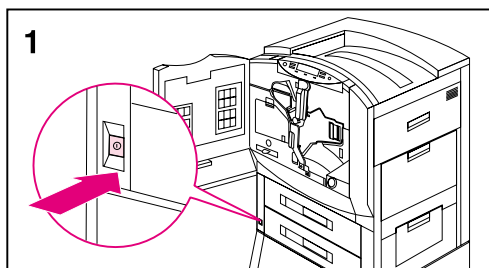

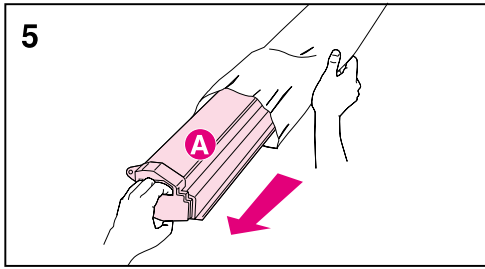

- 5 Remove the toner cartridge that matches the color of the sticker in the carousel slot from its packaging.

CAUTION

Do not lift or remove the shutter (A) on the cartridge.

Hold onto the ends of the toner cartridge. Squeezing the shutter area may cause damage to the cartridge.

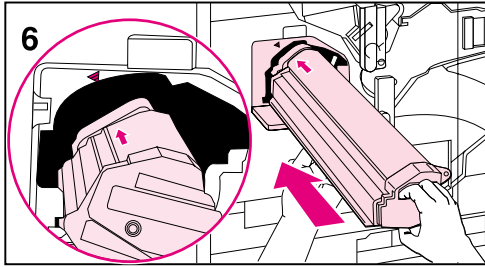

- 6 Align the arrow on the top of the cartridge with the arrow at the top of the opening and slide the cartridge into the printer.

Note

If the cartridge does not slide completely into the printer, make sure that the color of toner in the cartridge matches the colored sticker on the slot.

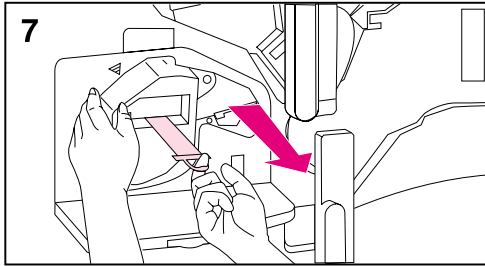

- 7 Place one hand on the cartridge and use the other hand to pull the orange ring and remove the seal. Set the seal aside.

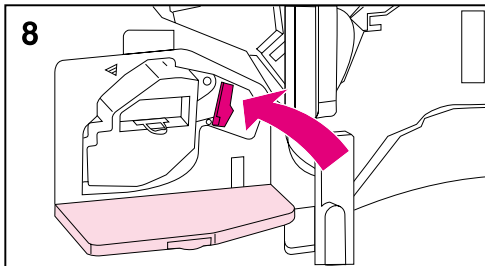

- 8 Push the blue locking lever two clicks to the left.

Note

If toner gets on fabric, wipe the toner off with a dry cloth and then wash the clothing in cold water. Warm water or the heat of a dryer will set toner into fabric.

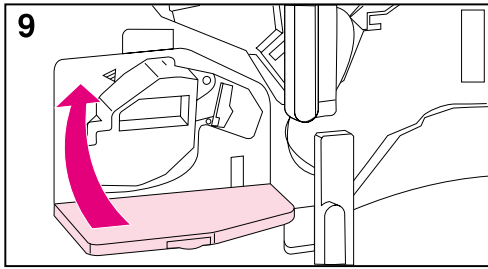

9 Close the clear door.

Note

If the clear door does not close, make sure that the blue lever is all the way to the left and the orange seal was removed.

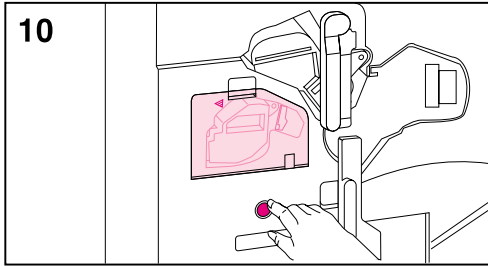

10 Press the blue button to rotate the carousel to the slot marked with a magenta sticker and repeat steps 3 through 9.

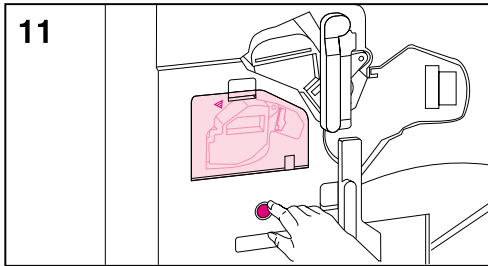

11 Press the blue button to rotate the carousel to the slot marked with a cyan (blue) sticker and repeat steps 3 through 9.

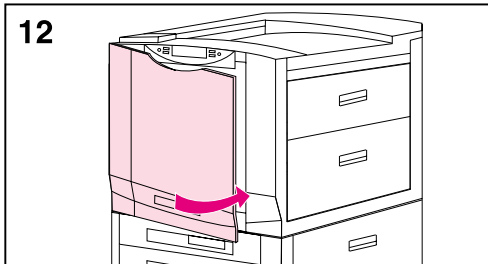

12 Close the front door; the printer will bring itself online within a few minutes and **READY** will appear on the control panel display.

Note

Reset the toner levels when you replace the toner cartridges. See the user guide for more information on resetting the toner levels.

Step 7: Loading the Input Trays

Figure 6

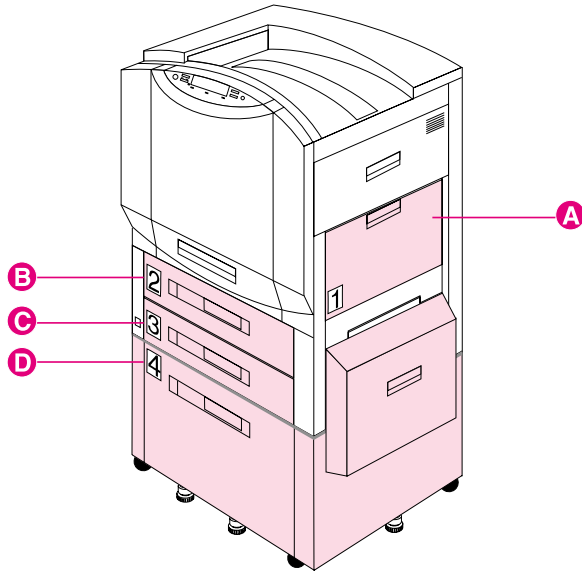

The printer has the following input trays:

- A** Tray 1 (multipurpose tray)
- B** Tray 2 (some printer models only)
- C** Tray 3
- D** Tray 4 (some printer models only)

These input trays contain media guides that are preset at the factory to a default media size, either letter or A4.

For more information about printing on different sizes and types of media, see the online user guide or the quick reference guide.

Loading media into trays 2 (some printer models only) and 3

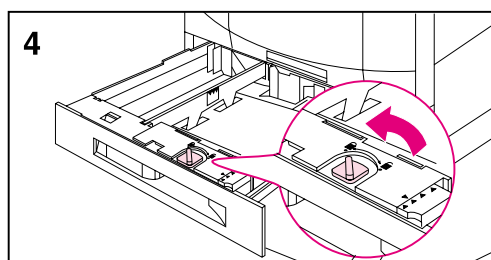
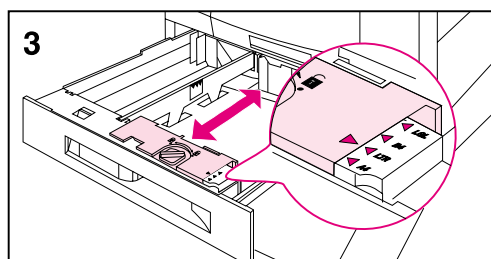
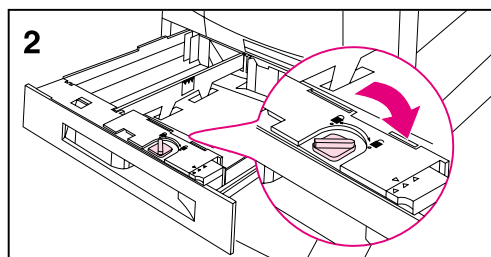
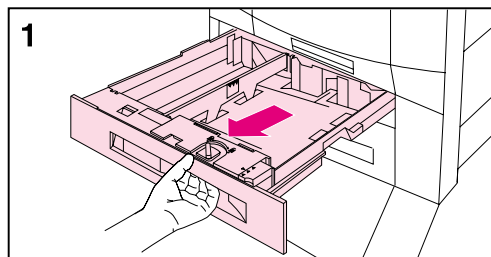

Note

Before loading media into trays 2 and 3, verify that the spacers were removed from both trays when “Step 2: Unpacking the Printer” was performed.

- 1 Firmly grip the handle in the center of the tray, squeeze the release lever, and pull the tray out until it stops.

Depending on your country, input trays arrive adjusted for either A4- or letter-sized media. To load A4- or letter-sized media, proceed to step 8; otherwise, continue with step 2.

- 2 Turn the media-guide lock to the unlocked position.
- 3 Slide the front media guide to the size that matches the media size you are loading.
- 4 Turn the media-guide lock to the locked position.

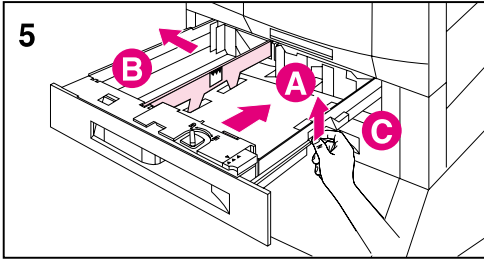

- 5 Adjust the left media guide by pushing it in (A) and lifting it up and out (B).

Note

Lift here (C) to remove paper from the tray.

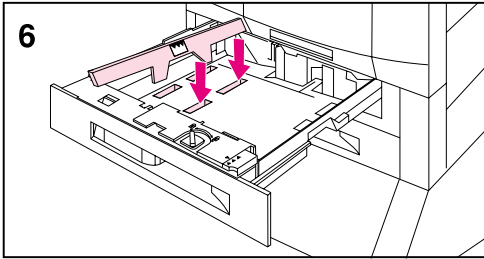

- 6 Position the guide over the appropriate media size marked in the tray.

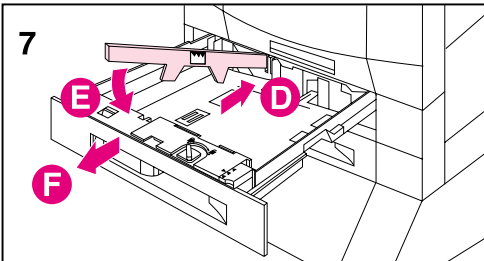

- 7 Press the guide into the rear slot (D), and then lower it down (E) into the front slot (F). Make sure the guide is not skewed.

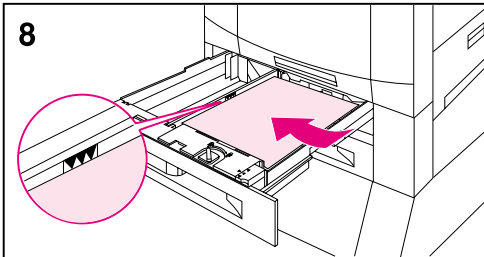

- 8 Load media into the tray up to the media-fill mark. For example, up to 500 sheets of 20 lb. (75 g/m²) bond paper will fit in the tray. For information on loading and orienting media, see the online user guide or the quick reference guide.

Note

Do not fill input trays above the media-fill mark. Too much media in the input trays can cause media jams.

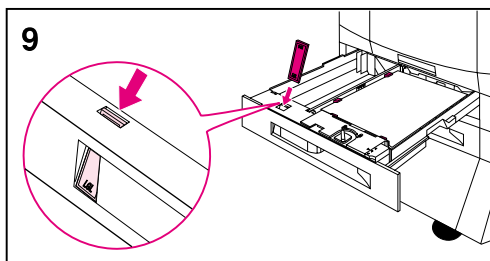

9 Make sure that the media-size tab on the front of the tray is set to the correct media size.

10 Slide the tray back into the printer.

11 Attach the left output bin (A) to the left side of the printer if you did not install an optional multi-bin mailbox.

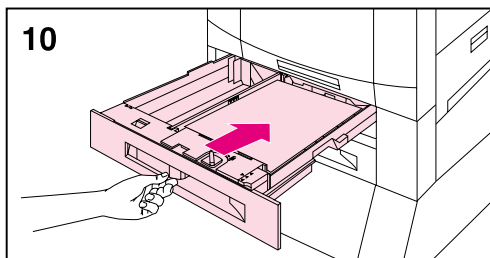

Set the media type for trays 2 and 3 in the printer control panel. For instructions, see “Step 8: Configuring Input Trays.”

Note

Always configure the media type in the printer control panel to prevent users from printing on the wrong media type.

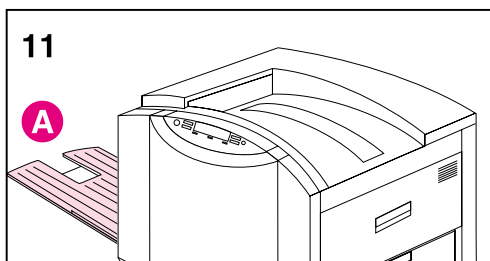

Loading media in the optional tray 4

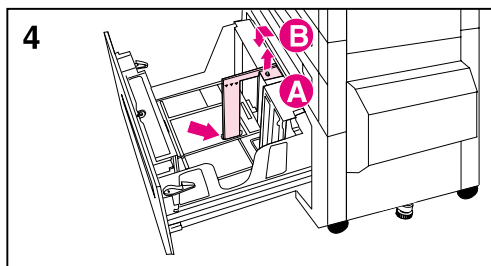
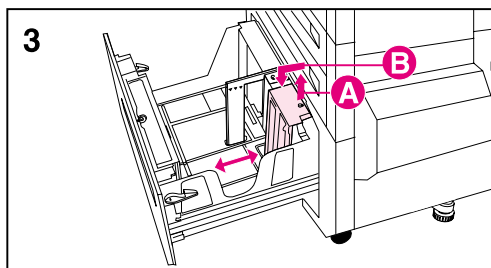
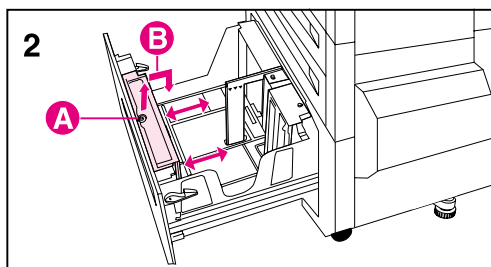
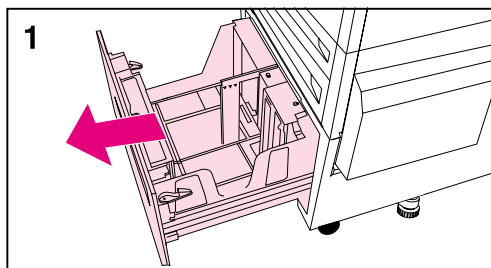

Note

Before loading media into tray 4, verify that the spacers were removed from the tray when “Step 2: Unpacking the Printer” was performed.

- 1 Firmly grip the handle in the center of the input tray, squeeze the release lever, and pull the tray out until it stops.

Depending on your country, tray 4 arrives adjusted for either A4- or letter-sized media. To load A4- or letter-sized media, proceed to step 5; otherwise, continue with step 2.

- 2 Adjust the front guide by pulling up on the pin (A), placing the guide into the slots on the top and bottom of the tray that correspond to the media size you are loading (B), and pushing in the pin.
- 3 Repeat step 2 to adjust the back guide.
- 4 Repeat step 2 to adjust the left media guide.

Note

To load 11-by-17 inch media, rotate the left media guide 90°, move it to the back of the tray, and place it into the slots on the top and bottom of the tray that correspond to 11-by-17.

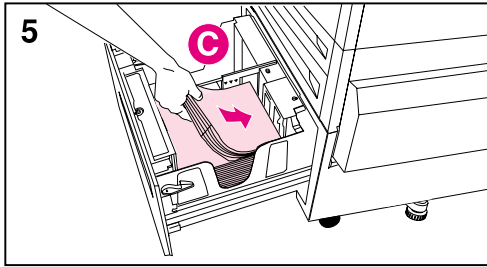

- 5 Load media into the tray up to the media-fill mark. For example, up to 2,000 sheets of 20 lb. (75 g/m²) bond paper will fit in the tray. For information on loading and orienting media, see the online user guide or the quick reference guide.

Note

Do not place anything in tray 4 to the left of the media guides (C) or the printer will not lift media out of the tray. Also, do not fill media above the media-fill mark on the left media guide. Too much media in the tray can cause media jams.

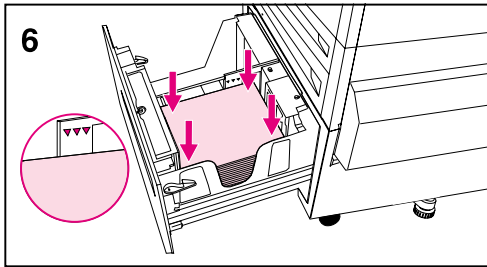

- 6 Press down on all four corners of the media stack to ensure the media rests flat in the tray.

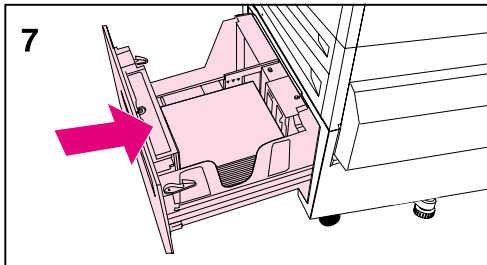

- 7 Close tray 4.

Set the media type for tray 4 in the printer control panel. For instructions, see “Step 8: Configuring Input Trays.”

Note

Always configure the media type in the printer control panel to prevent users from printing on the wrong media type.

Step 8: Configuring Input Trays

When input trays are configured correctly, the printer will print based on media type and size and will automatically use the correct input tray.

For example, tray 2 could contain letterhead; tray 3, plain legal-sized paper; and tray 4, plain letter-sized paper. If the trays are configured correctly, when you set up a print job you can choose the media type and size in the printer driver, and the printer will automatically print from the correct input tray.

Tray 1 Auto

From the control panel, you can also set the media size and type for tray 1 to AUTO. The printer tries to match the media size and/or type specified for the current print job in the print driver to the settings in the control panel and prints from tray 1 if it can. For example, if you set the media size and type for tray 1 to AUTO in the control panel, load letter-size transparencies into tray 1, and send a job to the printer specifying plain Letter in the print driver, the printer prints from tray 1 even if other trays are configured for plain Letter. You can use the AUTO setting to override the printer's tray selection process, forcing the printer to print from tray 1 regardless of the media size and/or type specified in the print driver or loaded in tray 1.

Note

Although tray 1 does not fully sense the media size, the printer will not print on media that it senses is the wrong width.

Configuring Media Type and Size

Configuring the media type is beneficial for several reasons:

- Configuring the media type prevents printing on the wrong (and possibly more expensive) media.
- If a user changes the type of media in an input tray, other users can still print on the correct media.
- The printer will automatically adjust its print speed to accommodate special media (such as card stock, labels, and transparencies). These adjustments will give the highest quality output, saving time and resources.

Note

If the media type is not set correctly, then the printer might not print on the correct media or at the correct speed for the media type, which can result in poor print quality.

To configure media type and size

Follow the steps below to configure the media type.

- 1 Press **MENU** until PAPER HANDLING MENU appears on the printer control panel display.
- 2 Press **ITEM** until TRAY [Number] TYPE = appears on the display.
- 3 Press **-VALUE+** until the correct media type appears on the display.
- 4 Press **SELECT** to save the selection. An asterisk (*) appears to the right of the selection.

To configure the media size in tray 1, repeat steps 1-4 ("size" will replace references to "type").

Note

Tray 2, tray 3, and the optional tray 4 automatically sense the media size.

- 5 Repeat steps 2 through 4 to configure media type in another tray.
- Or -
Press **GO** to bring the printer online.

Step 9: Printing a Configuration Page

Use the printer control panel to print a configuration page and verify that the printer was installed correctly. Configuration pages include the following information:

- General information about the printer (such as serial number and number of pages printed since most recent maintenance)
- Installed languages
- Print job errors
- Memory available and installed dual inline memory modules (DIMMs)
- Control panel and printer hard disk security
- Installed optional equipment (such as a tray 4 or duplexer)
- Tray configuration
- Network configuration
- Duplex registration
- Toner status
- Paper status
- Color settings

To print a configuration page

- 1 Press **MENU** until `INFORMATION MENU` appears on the printer control panel display.
- 2 Press **ITEM** until `PRINT CONFIG PAGE` appears on the display.
- 3 Press **SELECT** to print the configuration page. The printer will automatically bring itself online.

For more information about printing configuration pages, see the online user guide.

To verify communication with a parallel cable

To verify that the printer and computer are set up correctly to communicate with each other, print a directory list.

- 1 Turn the computer and printer on and wait for the printer to bring itself online (the printer is online when the Ready light on the printer control panel is lit).
- 2 At the MS-DOS® prompt, type `DIR>LPT1` and press **ENTER**.

Note

If you are using a UNIX® environment, use the equivalent commands.

- 3 If the Data light on the printer control panel display stays on, press **Go**. Otherwise, go to step 4, below.
- 4 If the printer prints the directory list, the printer setup is complete and the printer is ready for the software to be set up to work with the new printer.
 - Or -
If a message appears on the printer control panel, see the online user guide for more information about the message.
 - Or -
If the printer neither prints the directory list nor displays an error message on the printer control panel, check that all power cables are plugged in and that all cables connecting the printer and computer are securely fastened.

Communicating with an optional HP JetDirect internal print server

If the printer contains an optional HP JetDirect internal print server, and you cannot communicate with the printer over the network, verify the operation of the print server. Check the JetDirect configuration page, which was printed when the steps under “To print a configuration page” were performed. If the message “I/O CARD READY” does not appear on the JetDirect configuration page, see the troubleshooting section of the *HP JetDirect Print Server Software Installation Guide*.

HP JetDirect 10/100TX print server

If the printer contains an optional HP JetDirect 10/100TX print server, check to see that the print server was able to link to the network:

- Check the link-speed indicators (10 or 100) on the print server. If both are off, the print server failed to link to the network.
- Check the JetDirect configuration page, which was printed when the steps under “To print a configuration page” were performed. The message “LOSS OF CARRIER ERROR” indicates that the print server failed to link to the network.

If the print server failed to link, verify that all cables are correctly connected. If all cables are correctly connected and the print server still fails to link, turn the printer off and then on. After READY appears on the control panel, verify that the print server has connected. If the printer server did not connect, follow the steps below to reconfigure the print server:

- 1 Remove the HP JetDirect 10/100TX print server.
- 2 Use jumpers P1, P2, and P3 to manually configure the print server for either 10 or 100 Mbps (megabits per second) link speed, and Full- or Half-duplex operation according to the table below:

Print Server Operation	Jumper P1	Jumper P2	Jumper P3
Autonegotiation Enabled	AUTO	—	—
100 Half-duplex	(not AUTO)	100	H
100 Full-duplex	(not AUTO)	100	(not H)
10 Half-duplex	(not AUTO)	(not 100)	H
10 Full-duplex	(not AUTO)	(not 100)	(not H)

- 3** Reinstall the print server.
- 4** Verify that the configuration of the connecting network device (such as a 10/100TX network switch) matches. For example, to set the print server for 100TX Full-duplex operation, the port on the network switch must also be set for 100TX Full-duplex operation.
- 5** Turn the printer off and back on and check the print server operation. If the print server fails to link, contact a local authorized HP dealer or service representative.

Step 10: Understanding the Software

CD-ROMs are included with this printer. The CD-ROMs are divided by language. Under each language, the files are divided by operating system. All of the software and components (including the online user guide) that are available for the specific language and operating system are included under each operating system.

Structure of the CD-ROMs

Directories on the CDs:

Directory	Subdirectory 1	Subdirectory 2	Subdirectory 3
\<language> (for example, \ENGLISH, \DANSK, \DEUTSCH, and so forth)	\<operating system> (for example, \WIN3x, \WIN9x, \WINNT, Autocad, Pantone, OS2, ICM, and so forth)	\DISK1...DISKn, Files (depending on directory path)	Files

Note

Depending on the operating system in use, some of the directories might not be visible. For example, if you are using Microsoft Windows 9x, you will not be able to access the Macintosh directory.

Installing the Software

For printers with the optional HP JetDirect internal print server, you might have to set certain network parameters depending upon the network configuration. For most networks, you can configure these parameters from the HP Web JetAdmin software which is available on the HP Web site (www.hp.com). For more information about how to set network parameters in the printer control panel, see the online user guide.

For information about sharing the printer through the parallel port connection, see the computers documentation.

- For Microsoft Windows network installation instructions, see Step 11: Windows Network Installation.
- For IBM LAN server network installation instructions, see Step 12: IBM LAN Server Network Installation.
- For Macintosh network installation instructions, see Step 13: Macintosh Network Installation.

A variety of the following operating systems are also supported by this printer, but the software must be obtained from the HP Web site:

- HP-UX
- SunOS
- Solaris

To order the software, call your operating system software vendor or contact HP through CompuServe, the World Wide Web, HP Distribution, or HP FIRST. See the online user guide for addresses, phone numbers, and URLs of these services.

Accessing the Online User Guide

The online user guide is automatically installed with the Typical install. If you want to install only the online user guide, use the Custom option from the installer. (See Step 11: Windows Network Installation.)

The online user guide and the software needed to read the guide—Adobe™ Acrobat Reader—can be installed on your computer's hard disk or can be read from the CD-ROM drive.

The reader software allows you to scroll through the online user guide, by pressing **PAGE UP** and **PAGE DOWN** or by using a mouse to click the scroll bar.

Additionally, it offers fast access to subjects in which you are interested through its table of contents and its index. Table of Contents and Index should always be displayed on the left-hand side of the screen. The table of contents or index will be displayed automatically when you click them. When the table of contents or the index is displayed on the screen, simply click the subjects to display the information.

There are additional navigation tools and viewing options under the **View** and **Tools** menus to help you explore the online user guide.

To access the online user guide from the hard disk

- Microsoft Windows 9x, Windows NT, and Windows 2000 users click **Start**, point to **Programs**, then **HP LaserJet**, and click the online user guide icon.
- Microsoft Windows 3.1 *x* users locate the HP LaserJet group and double-click the online user guide icon.
- Macintosh users locate the HP LaserJet group and double-click the online user guide icon.

To access the online user guide from the CD-ROM

- 1** Insert the CD-ROM that corresponds to your language into the CD-ROM drive.
- 2** If you already have Adobe Acrobat Reader installed on your computer's hard drive, open Acrobat Reader and then open the online user guide from your CD-ROM drive.
-Or-
If you do not already have Adobe Acrobat Reader, use your operating systems file management utility to locate the online user guide and then double-click the online user guide. Then locate Adobe Acrobat Reader and double-click Adobe Acrobat Reader.

Additional Information

Information that was not available when this guide was printed can be found in the readme file, which is copied onto the hard disk during installation.

Step 11: Windows Network Installation

In Microsoft Windows 9x, Windows NT® 4.0, and Windows 2000, the installation software detects both the version of Windows that is in use and the language that is selected in the operating system. The installation software then installs printer drivers and printing software that are appropriate for the system.

For Novell NetWare networks, install the software on the workstation. For Windows NT and Windows 2000 networks with a client server, install the software on the server. For Windows 9x peer-to-peer networks, install the software on all workstations that need access to the printer.

The installation software does not support shared Windows 3.1 environments.

To install the Windows printer software for system administrators

- 1 Depending on the environment, log onto the workstation or log onto the server with Supervisor or Administrator privileges.
- 2 Quit all applications, virus checkers, and TSR (terminate stay resident) programs. These programs can be turned back on after the installation.
- 3 Insert the CD-ROM into the CD-ROM drive. The installer should automatically run; go to step 8. If the installer does not automatically run, continue to step 4.
- 4 In Windows 3.1, choose **Run** from the **File** menu.
- Or -
In Windows 9x, NT 4.0, or Windows 2000, click **Start**, then click **Run**.
- 5 Type `D:\Setup.exe` on the command line. (This assumes that the CD-ROM drive is the D drive.)
- 6 Click **OK**.

- 7** To install printer software for the language and version of Windows on the computer, click **Continue**.
To install printing software in another language, click **Exit** and use the Structure of the CD-ROMs section in Step 10: Understanding the Software to find the path for the language you want to install. For example, to install printing software for Windows 9x in Spanish, the path is D:\Espanol\Win 95\Disk1\Setup.exe.
- 8** Choose an installation type that fits your needs.

Installation Type	Components Installed
Typical Installation	PCL and PostScript drivers, and the online user guide
Custom Installation	Allows you to choose components

Note

To make the PCL driver the default driver, see the read8550.wri file on the CD ROM.

- 9** If you do not already have a port set up, choose **LPT1** when prompted to choose a port for the printer. You can assign the correct port when you configure the printer on the network.

Configuring the Printer on the Network

Before you can use the printer, configure it on the network. HP recommends that you use a printer management utility such as the HP Web JetAdmin software, PCONSOLE, or NWADMIN. Configuring the printer on the network involves steps such as setting up a print queue or port.

To configure the printer, see the information for this network contained in the *HP JetDirect Print Server Software Installation Guide*.

The printer can also be configured in the printer control panel. To configure the printer in the printer control panel, see the online user guide.

Distributing the Printer Software to Network Clients

Before a client can print to the printer, the printer software must be installed on the clients' workstation. Rather than distributing the compact disc to each client, disk images of the installation software can be placed in a public directory or onto diskettes. The Windows installer has a mode that creates custom disk images. This option allows administrators to create a unique installer image in a directory of their choice. For example, you can create a version of the installer containing only the PCL driver and the online user guide on a network drive that is accessible to other users.

When you run the installer, it automatically detects the operating system and default language running on the workstation. The custom disk image created uses these default language and operating system selections. To create a custom disk image for a specific language or operating system, run the Windows installer on a workstation that uses that operating system or language, or use a different tool to create the disk images. Use a file management tool such as Windows File Manager or XCOPY to copy disk images. Use the Structure of the CD-ROMs section in Step 10: Understanding the Software to determine the location of the disk images on the CD-ROM. For example, to copy disk images for Windows 9x in Spanish, the path on the CD-ROM is d:\Españo\Win95.

Creating Disk Images with the Windows Installer

- 1 Insert the CD-ROM into the CD-ROM drive.
- 2 In the Windows 3.1x *Program Manager*, select **Run** from the **File** menu.
- Or -
In Windows 9x, NT 4.0, or Windows 2000, click **Start** then select **Run**.
- 3 Type `D:\<language>\<OS>\Disk1\Setup.exe` on the command line. (This assumes that the CD-ROM drive is the D drive.)
- 4 Click **OK**.
- 5 Click **Continue**.
- 6 When you are prompted to choose the method of installation, click **Disk Images**.
- 7 Click **Browse** to assign a path to the drive and directory to which you want to copy.
- 8 Click **Continue** and follow the instructions on the screen.

Installing the Printer Software for Network Clients

Before network clients can print to the printer, the printers software must be installed on their workstations. The installation procedures are similar to the installation procedures for system administrators. Install the software by running `Setup.exe` from the root directory of the CD-ROM or from a disk image copied with **Disk Images**.

- To install network client software, choose **Typical Installation**, which includes PCL and PostScript drives and the online user guide for Windows 3.1, Windows 9x, Windows NT, and Windows 2000.

Note

Do not install the PCL or PostScript drivers on workstations that connect to Windows NT and Windows 2000 servers when you install other network client software. Clear the PCL and PostScript Driver check boxes in the **Components** list during the Custom Install. The drivers will be installed from the server when you connect to a network printer (later in this section).

- For a custom installation on a Windows 3.1 or 9x workstation, use the custom installation option in the installer.

For more information, see the chapters on peer-to-peer networks in the *HP JetDirect Print Server Software Installation Guide*.

Connecting Network Clients to the Printer

After installing the software on a workstation, you must connect the workstation to the printer.

- Workstations in Windows 9x can be connected to the print server or directly to the printer.
- Workstations in Windows NT, Windows 2000, and Windows 3.1 can be connected to the print server.

To connect workstations to the print server

Connect the printer drivers to the printer on the proper port.

- In Windows 3.1, double-click **Printers** in the Control Panel, then select **Connect** to connect the printer driver to the network. If the network port is not visible in the **Ports** list, then click **Network** and complete the **Connect to Network** dialog box.
- In Windows 9x, select the printer in the **Printers** folder. Then from the **File** menu, select **Properties**. Select the correct port on the **Details** tab. If the port is not present, click **Add Port** and browse for the correct path to the printer.
- When you connect to a network printer from a Windows NT or Windows 2000 workstation, the printer driver will be automatically installed if you use a Windows NT or Windows 2000 server. If the operating system is unable to install the driver from the server, you can install the driver from the CD-ROM. If you are prompted for the driver, browse for HPB8550S.INF (PostScript) or HPB8550C.INF (PCL 5c) in the \<language>\WINNT\<OS>\Disk1 subdirectory, where <language> is your currently selected language and <OS> is your current operating system.

Note

To connect to a network printer from a Windows NT or Windows 2000 workstation, you must have administrator privileges on that workstation.

In Windows NT and Windows 2000, there are three options for connecting to a network printer:

- Open **Network Neighborhood** and locate the printer on the network. Drag and drop the printers icon from **Network Neighborhood** to the **Printers** folder.
- Open **Network Neighborhood** and double-click the printer icon. Follow the instructions on the screen for connecting to a printer.
- Use the **Add Printer Wizard** in the **Printers** folder to connect to a network printer.

To connect Windows 9x, Windows NT 4.0, and Windows 2000 workstations directly to the printer

- 1 Click **Start**.
- 2 Click **Settings**.
- 3 Click **Printers**.
- 4 Right-click the icon for this printer to open a shortcut menu.
- 5 Click **Properties** on the shortcut menu.
- 6 Click the **Details** tab.
- 7 Click **Add Port**.
- 8 Select **Other** and highlight **HP JetDirect Port** by clicking it. This opens the Add HP JetDirect Port Wizard.
- 9 Follow the instructions in Add HP JetDirect Port Wizard for TCP/IP printer or IPX/SPX printer.

For more information, see the *HP JetDirect Print Server Software Installation Guide*.

Step 12: IBM LAN Network Installation

Distributing the Printer Software to Network Clients

Before a client can print to the printer, the printer software must be installed on the clients workstation. Rather than distributing the CD-ROM to each client, disk images of the installation software can be placed in a public directory or onto diskettes.

Use a file management tool to copy disk images. Use the Structure of the CD-ROMs section in Step 10: Understanding the Software to determine the location of the disk images on the CD-ROM.

Installing the Printer Software for Network Clients

Use the following information to install the OS/2 PCL driver or OS/2 PostScript driver on OS/2 systems (versions 2.0 with Service Pak or later of the OS/2 operating system).

To install a driver if a printer was NOT selected during the OS/2 installation

- 1 Double-click the **Templates Folder** in the OS/2 system folder.
- 2 Using the right mouse button, drag the **Printer** template to the desktop. The Create a Printer window opens.
- 3 In the **Name** field, type a name for the printer.
- 4 Click the port to which the printer is connected.
- 5 Click **Install new printer driver**. A window appears with a list of the printer drivers that are shipped with OS/2.
- 6 Click **Other printer driver**.
- 7 Insert the CD-ROM into the CD-ROM drive.

- 8 In the **Directory** field, type:
D:\english\OS2\`<driver\`
(This assumes that the CD-ROM drive is the D drive and that you are installing the English driver.)
For `<driver>`, type: PCL or PS.
- 9 Click **Refresh**. Printer drivers appear in the window.
- 10 Select the **HP Color LaserJet 8550** driver.
- 11 Click **Install**.

To install a driver if the printer was selected during the OS/2 installation

- 1 Right-click the printer icon on the desktop.
- 2 Select **Settings** or **Properties**.
- 3 Click the **Printer Driver** tab.
- 4 Right-click one of the printer driver objects.
- 5 Click **Install**.
- 6 Select **Other OS/2 printer driver**.
- 7 Insert the CD-ROM into the CD-ROM drive.
- 8 In the **Directory** field, type:
D:\english\OS2\`<driver\`
(This assumes that the CD-ROM drive is the D drive and that you are installing the English driver.)
For `<driver>`, type: PCL or PS.
- 9 Click **Refresh**. Wait until the window fills with printer drivers.
- 10 Select **HP Color LaserJet 8550**.
- 11 Click **Install**.

Connecting Network Clients to the Printer

After installing the end-user software on a client workstation, you must connect the printer drivers to the printer on the proper port.

Step 13: Macintosh Network Installation

Installing the Macintosh Printer Software

The Macintosh printer driver for this printer supports system version 7.0 or later.

For an EtherTalk or LocalTalk network, install the software on each workstation. The installation procedures are the same for an administrator and a client workstation. The Mac OS portion on the compact disc contains an installer program for each language.

Find the language that is appropriate for the operating system and then use the installer program for that language.

To install printer software for system 7.5 or later

- 1 Restart the computer while holding down the space bar. This opens the Extensions Manager.
- 2 From the Extensions Manager, disable all extensions except the ones needed to run the CD-ROM drive.
- 3 Close the Extensions Manager.
- 4 Insert the CD-ROM into the CD-ROM drive.
- 5 Double-click **HP Color LaserJet 8550 Printer Installer** for your language and then follow the instructions on the screen.
- 6 After you complete the installation, restart the computer while holding down the space bar.
- 7 Open the Extensions Manager and re-enable the extensions you disabled in step 2 above.
- 8 In **Chooser**, select **HP Color LaserJet 8550**. (For instructions, see Connecting Network Clients to the Printer later in this section.)

Connecting Network Clients to the Printer

If you are not using a print spooler or a print queue, follow the directions below to connect the printer drivers to the printer automatically. If you are using a print spooler or if the automatic setup is unsuccessful, follow the directions below to configure the printer driver manually.

To connect to the printer automatically

- 1 From the **Apple** menu, select **Chooser**.
- 2 From the list of icons along the left side of **Chooser**, click **HP LaserJet**.
- 3 In the **AppleTalk Zones** box, click the zone where the printer is located (if applicable).
- 4 From the list of printer names along the right side of **Chooser**, select the name of the printer (even if it is the only one that appears).

Note

You might have to print a configuration page to determine the printers AppleTalk name.

- 5 Click **Setup**. A status dialog box appears while the printer driver attempts to communicate with the printer.
- 6 If the setup is successful, you will be returned to **Chooser** and an icon appears next to the selected printer. Close **Chooser**.
- Or -
If setup was not successful, go to the procedure below.

To configure the printer driver manually

- 1 From the **Apple** menu, select **Chooser**.
- 2 From the list of icons along the left side of **Chooser**, click **HP LaserJet**.
- 3 In the **AppleTalk Zones** box, click the zone where the printer is located (if applicable).

- 4 From the list of printer names along the right side of **Chooser**, select the name of the printer (even if it is the only one that appears).
- 5 Click **Setup**.
- 6 Click **Select PPD**.
- 7 From the list of PPD files, click **HP Color LaserJet 8550 Printer**.
- 8 Click **Select**.
- 9 Click **Configure**.
- 10 Enter the appropriate selections for the printers installed options and click **OK**.
- 11 Click **OK** to complete the setup. An icon appears next to the name of the printer.
- 12 Close **Chooser**.

Configuring the Printer on the Network

Configure the printer in one of two ways:

- Print directly to the printer through EtherTalk.
- Print through the network by printing to a print queue. Set up the print queue using the network software.

The HP LaserJet Utility allows printer settings such as printer name and preferred zone to be configured from the Macintosh system. HP recommends that only system administrators use the printer configuration capabilities of this utility.

If the printer is to be serviced by a print spooler, set up the printers name and zone before configuring the spooler to capture the printer.

Distributing the Printer Software to Network Clients

Before a client can print to the printer, the printer software must be installed on the clients workstation. Rather than distributing the CD-ROM to each client, disk images of the installation software can be placed in a public directory or onto diskettes.

Use a file management tool to copy disk images. Use the Structure of the CD-ROMs section in Step 10: Understanding the Software to determine the location of the disk images on the compact disc.

Installing the Macintosh Printer Software for Network Clients

The installation procedures are the same for an administrator or a client workstation. Follow the instructions detailed in Installing the Macintosh Printer Software at the beginning of this section.

Troubleshooting Checklist

If the printer does not appear to be functioning correctly, check the following items:

Problem or Error Message	Solution
<p>The printer control panel display is blank.</p>	<p>Make sure the printer's power switch is on.</p> <p>The printer might be in Power Save mode. Press Go.</p> <p>This printer may require 220 volts of power and is only being supplied with 110 volts.</p> <p>Make sure all power cables are securely attached and plugged into a grounded power source.</p>
<p>The printer control panel displays OFFLINE</p>	<p>Press Go.</p>
<p>Printer control panel displays EIO 1 INITIALIZING.</p>	<p>Either no cable, a bad cable, or only a LocalTalk cable is attached to the HP JetDirect internal print server.</p> <p>For LocalTalk connections, the message should disappear after approximately 5 minutes, during which normal printing is possible. Check the cable connection.</p> <p>The HP JetDirect internal print server might be improperly installed. Reinstall the print server.</p> <p>There might be a network problem. See the <i>HP JetDirect Print Server Software Installation Guide</i>. Also, see <i>Step 4: Connecting the Printer to the Network about how to add 50-Ohm terminators, if necessary</i>.</p>
<p>Cannot print from the computer using a parallel cable.</p>	<p>The cable might be installed incorrectly, too long, or faulty. Remove the cable and reconnect it, making sure it is securely connected. Try another parallel cable that is 30 feet or less, IEEE-1284 compliant, with a "C" size connection. Replace the cable with an HP parallel cable (part number C2946A) or equivalent.</p> <p>The wrong port might be selected or rerouted. Check the MODE statement in the AUTOEXEC.BAT file. In Windows 3.1, look in the Control Panel to see which port is selected. In Windows 9x, Windows NT, or Windows 2000, check the Parallel Port Capture.</p> <p>There might be a bad port on the computer or printer. Try using a different port or, if possible, a different computer or printer to isolate the problem.</p>

Cannot print using a sharing device.	Try to isolate the cause of the problem. Test the printer using a cable connected directly from the computer to the printer. Contact the sharing device vendor for troubleshooting steps.
Random garbage characters are printing.	The interface cable might be bad or loose. Check the cable and connection. Try another parallel cable that is 30 feet or less, IEEE-1284 compliant, with a "C" size connection. Replace the cable with an HP Parallel cable (part number C2946A) or equivalent.
Printer control panel displays CLEAR PAPER JAM.	Media might be jammed in one of several locations. Clear all jams according to instructions in the quick reference guide.
Printer control panel displays an unfamiliar message.	Turn the printer off, then back on. If the message does not clear, see the online user guide for more information.

For more printer control panel messages and troubleshooting solutions, see the online user guide.



Copyright© 2000
Hewlett-Packard Company
Printed in USA 04/00

**Manual Part No.
C7096-90923**



Printed on at least
50% Total Recycled Fiber with
at least 10% Post-Consumer Paper



C7096-90923

Free Manuals Download Website

<http://myh66.com>

<http://usermanuals.us>

<http://www.somanuals.com>

<http://www.4manuals.cc>

<http://www.manual-lib.com>

<http://www.404manual.com>

<http://www.luxmanual.com>

<http://aubethermostatmanual.com>

Golf course search by state

<http://golfingnear.com>

Email search by domain

<http://emailbydomain.com>

Auto manuals search

<http://auto.somanuals.com>

TV manuals search

<http://tv.somanuals.com>