

# HP Apollo 2000 System User Guide

## Abstract

This document is for the person who installs, administers, and troubleshoots servers and storage systems. HP assumes you are qualified in the servicing of computer equipment and trained in recognizing hazards in products with hazardous energy levels.



Part Number: 797871-001  
March 2015  
Edition: 1

© Copyright 2015 Hewlett-Packard Development Company, L.P.

The information contained herein is subject to change without notice. The only warranties for HP products and services are set forth in the express warranty statements accompanying such products and services. Nothing herein should be construed as constituting an additional warranty. HP shall not be liable for technical or editorial errors or omissions contained herein.

Linux® is the registered trademark of Linus Torvalds in the U.S. and other countries.

Microsoft® and Windows® are U.S. registered trademarks of the Microsoft group of companies.

MicroSD is a trademark or a registered trademark of SD-3C in the United States, other countries or both.

Red Hat® is a registered trademark of Red Hat, Inc. in the United States and other countries.

VMware® is a registered trademark of trademark of VMware, Inc. in the United States and/or other jurisdictions.

---

# Contents

HP Apollo 2000 System .....	8
Introduction .....	8
Component identification .....	9
Chassis front panel components .....	9
Chassis front panel LEDs and buttons .....	10
Chassis rear panel components .....	11
Chassis rear panel LEDs .....	12
Node rear panel components .....	13
Node rear panel LEDs and buttons .....	14
Power fault LEDs .....	16
System board components .....	16
System maintenance switch .....	17
NMI functionality .....	18
DIMM slot locations .....	19
Fan locations .....	19
Drive numbering .....	19
HP Apollo r2200 Chassis drive numbering .....	20
HP Apollo r2600 Chassis drive numbering .....	20
M.2 SATA SSD bay numbering .....	22
Hot-plug drive LED definitions .....	22
HP SmartDrive LED definitions .....	22
Low-profile LFF hot-plug drive LED definitions .....	24
RCM module components .....	25
RCM module LEDs .....	26
PCIe riser board slot definitions .....	27
Operations .....	31
Power up the nodes .....	31
Power down the system .....	31
Power down the node .....	31
Remove the node from the chassis .....	32
Remove the RCM module .....	33
Remove the power supply .....	33
Remove the chassis from the rack .....	34
Remove the security bezel .....	35
Removing the drive .....	35
Remove the chassis access panel .....	36
Install the chassis access panel .....	37
Remove the 1U left rear I/O blank .....	38
Install the 1U left rear I/O blank .....	38
Remove the 1U right rear I/O blank .....	39
Install the 1U right rear I/O blank .....	40
Remove the 2U rear I/O blank .....	40
Install the 2U node rear I/O blank .....	41
Remove the air baffle .....	41
Install the air baffle .....	42

Remove the bayonet board assembly .....	43
Install the bayonet board assembly .....	44
Remove the bayonet board bracket .....	46
Install the bayonet board bracket .....	47
Remove the PCI riser cage assembly .....	48
Single-slot left PCI riser cage assembly .....	48
Single-slot 1U node right PCI riser cage assembly .....	50
FlexibleLOM 1U node riser cage assembly .....	50
Single-slot 2U node PCI riser cage assembly .....	51
FlexibleLOM 2U node riser cage assembly .....	52
Three-slot PCI riser cage assemblies .....	53
<b>Setup.....</b>	<b>54</b>
Installation overview .....	54
Optional services .....	54
Optimum environment.....	55
Space and airflow requirements .....	55
Temperature requirements.....	56
Power requirements .....	56
Electrical grounding requirements .....	56
Server warnings and cautions .....	57
Rack warnings .....	57
Identifying the contents of the server shipping carton.....	58
Preparing the chassis .....	58
Installing hardware options.....	59
Installing the chassis into the rack .....	59
Chassis component installation.....	60
Installing a node into the chassis .....	60
Installing a drive.....	61
Installing the power supplies .....	61
Powering up the chassis .....	62
HP Advanced Power Manager (optional).....	62
Powering on and selecting boot options in UEFI Boot Mode.....	62
Installing the operating system.....	62
Installing the system software .....	63
Registering the server.....	63
<b>Hardware options installation.....</b>	<b>64</b>
Introduction .....	64
Security bezel option .....	64
Drive options .....	64
Removing a drive blank.....	65
Installing a hot-plug drive.....	65
Node blank.....	67
Rack control management (RCM) module .....	67
RCM 2.0 to 1.0 adapter cable .....	69
Redundant fan option .....	70
Fan population guidelines.....	70
Installing the fan option .....	71
Memory options.....	72
HP SmartMemory .....	73
Memory subsystem architecture .....	73
Single-, dual-, and quad-rank DIMMs .....	74
DIMM identification .....	74

Memory configurations.....	75
General DIMM slot population guidelines.....	76
Installing a DIMM.....	77
Storage cable options.....	78
B140i 1U node SATA cable.....	78
B140i 2U node SATA cable.....	79
Mini-SAS H240 1U node cable option.....	80
Mini-SAS H240 2U node cable option.....	81
Mini-SAS P440/P840 cable option.....	82
Mini-SAS P440 2U node cable option.....	83
PCI riser cage assembly options.....	84
Single-slot left PCI riser cage assembly option.....	85
Single-slot 1U node right PCI riser cage assembly option.....	87
Single-slot 2U node PCI riser cage assembly option.....	88
FlexibleLOM 1U node riser cage assembly option.....	90
FlexibleLOM 2U node riser cage assembly option.....	92
Three-slot PCI riser cage assembly options.....	93
Controller options.....	96
Storage controller installation guidelines.....	97
Installing the storage controller and FBWC module options.....	97
Installing the HP Smart Storage Battery.....	99
Graphic card options.....	101
Graphic card/coprocessor power setting switch.....	101
Single graphic card/ coprocessor power cable option.....	101
Dual graphic card/ coprocessor power cable option.....	103
NVIDIA Tesla K40 12GB Module Enablement Kit.....	106
Intel Coprocessor Enablement Kit.....	114
M.2 SATA SSD enablement board.....	121
Processor and heatsink.....	123
Dedicated iLO management port module option.....	127
Enabling the dedicated iLO management module.....	129
HP Trusted Platform Module option.....	129
Installing the Trusted Platform Module board.....	130
Retaining the recovery key/password.....	131
Enabling the Trusted Platform Module.....	131
<b>Cabling.....</b>	<b>133</b>
Chassis cabling.....	133
Front I/O cabling.....	133
Drive backplane power cabling.....	134
RCM 2.0 cabling.....	135
Fan power cabling.....	135
Fan cabling.....	136
HP Smart Storage Battery cabling.....	136
Node cabling.....	137
Storage cabling.....	137
Graphic card/ coprocessor cabling.....	139
FBWC module cabling.....	140
<b>Software and configuration utilities.....</b>	<b>143</b>
Server mode.....	143
Product QuickSpecs.....	143
HP iLO.....	143
Active Health System.....	144

HP RESTful API support for HP iLO .....	145
Integrated Management Log .....	145
HP Insight Remote Support .....	146
Intelligent Provisioning .....	146
HP Insight Diagnostics .....	147
Erase Utility .....	147
Scripting Toolkit for Windows and Linux .....	148
HP Service Pack for ProLiant .....	148
HP Smart Update Manager .....	148
HP UEFI System Utilities .....	149
Using HP UEFI System Utilities .....	149
Flexible boot control .....	149
Restoring and customizing configuration settings .....	150
Secure Boot configuration .....	150
Embedded UEFI shell .....	151
Embedded Diagnostics option .....	151
HP RESTful API support for UEFI .....	151
Re-entering the server serial number and product ID .....	151
Utilities and features .....	152
HP Smart Storage Administrator .....	152
Automatic Server Recovery .....	152
USB support .....	152
Redundant ROM support .....	153
Keeping the system current .....	153
Access to HP Support Materials .....	153
Updating firmware or System ROM .....	154
Drivers .....	155
Software and firmware .....	156
Operating System Version Support .....	156
Version control .....	156
HP operating systems and virtualization software support for ProLiant servers .....	157
HP Technology Service Portfolio .....	157
Change control and proactive notification .....	157
<b>System battery .....</b>	<b>158</b>
<b>Troubleshooting .....</b>	<b>160</b>
Troubleshooting resources .....	160
<b>Regulatory information .....</b>	<b>161</b>
Safety and regulatory compliance .....	161
Belarus Kazakhstan Russia marking .....	161
Turkey RoHS material content declaration .....	162
Ukraine RoHS material content declaration .....	162
Warranty information .....	162
<b>Electrostatic discharge .....</b>	<b>163</b>
Preventing electrostatic discharge .....	163
Grounding methods to prevent electrostatic discharge .....	163
<b>Specifications .....</b>	<b>164</b>
Environmental specifications .....	164
Mechanical specifications .....	164
Power supply specifications .....	165
Hot-plug power supply calculations .....	166

Support and other resources .....	167
Before you contact HP .....	167
HP contact information .....	167
Acronyms and abbreviations .....	168
Documentation feedback .....	172
Index .....	173

---

# HP Apollo 2000 System

## Introduction

The HP Apollo 2000 System consists of a chassis and nodes.

### Chassis

- HP Apollo r2200 Chassis (12 low-profile LFF hot-plug drives)
- HP Apollo r2600 Chassis (24 SFF hot-plug drives)

### Nodes

- HP ProLiant XL170r Gen9 Server Nodes (1U)
- HP ProLiant XL190r Gen9 Server Nodes (2U)

One chassis can support a maximum of:

- Four 1U nodes
- Two 1U nodes and one 2U node
- Two 2U nodes

For more information about product features, specifications, options, configurations, and compatibility, see the product QuickSpecs on the HP website (<http://www.hp.com/go/qs>).



# Component identification

## Chassis front panel components

- HP Apollo r2200 Chassis

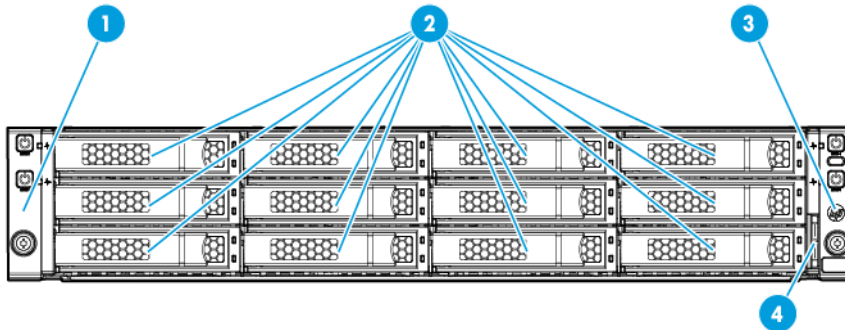

Item	Description
1	Left bezel ear
2	Low-profile LFF hot-plug drives
3	Right bezel ear
4	Chassis serial label pull tab

- HP Apollo r2600 Chassis

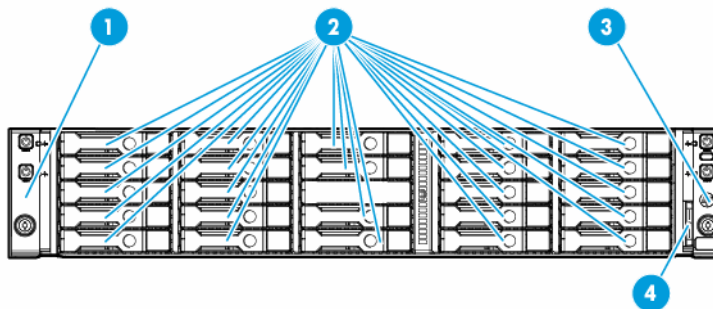

Item	Description
1	Left bezel ear
2	SFF HP SmartDrives
3	Right bezel ear
4	Chassis serial label pull tab

# Chassis front panel LEDs and buttons

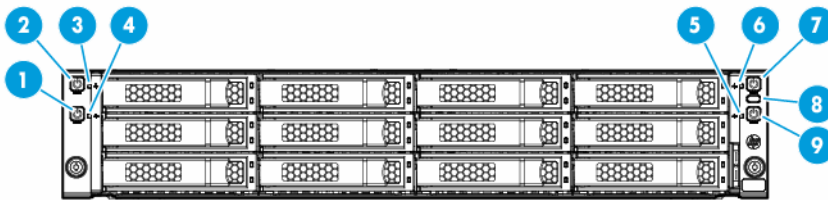

Item	Description	Status
1	Power On/Standby button and system power LED (Node 1)*	Solid green = System on Flashing green = Performing power on sequence Solid amber = System in standby Off = No power present**
2	Power On/Standby button and system power LED (Node 2)*	Solid green = System on Flashing green = Performing power on sequence Solid amber = System in standby Off = No power present**
3	Health LED (Node 2)*	Solid green = Normal Flashing amber = System degraded Flashing red = System critical†
4	Health LED (Node 1)*	Solid green = Normal Flashing amber = System degraded Flashing red = System critical†
5	Health LED (Node 3)*	Solid green = Normal Flashing amber = System degraded Flashing red = System critical†
6	Health LED (Node 4)*	Solid green = Normal Flashing amber = System degraded Flashing red = System critical†
7	Power On/Standby button and system power LED (Node 4)*	Solid green = System on Flashing green = Performing power on sequence Solid amber = System in standby Off = No power present**
8	UID button/LED*	Solid blue = Activated Flashing blue: <ul style="list-style-type: none"> <li>• 1 Hz/cycle per sec = Remote management or firmware upgrade in progress</li> <li>• 4 Hz/cycle per sec = iLO manual soft reboot sequence initiated</li> <li>• 8 Hz/cycle per sec = iLO manual hard reboot sequence in progress</li> </ul> Off = Deactivated

Item	Description	Status
9	Power On/Standby button and system power LED (Node 3)*	Solid green = System on Flashing green = Performing power on sequence Solid amber = System in standby Off = No power present**

\* When the LEDs described in this table flash simultaneously, a power fault has occurred. For more information, see "Power fault LEDs (on page 16)."

\*\* Facility power is not present, power cord is not attached, no power supplies are installed, power supply failure has occurred, or the front I/O cable is disconnected.

† If the health LED indicates a degraded or critical state, review the system IML or use iLO to review the system health status.

## Chassis rear panel components

- Four 1U nodes

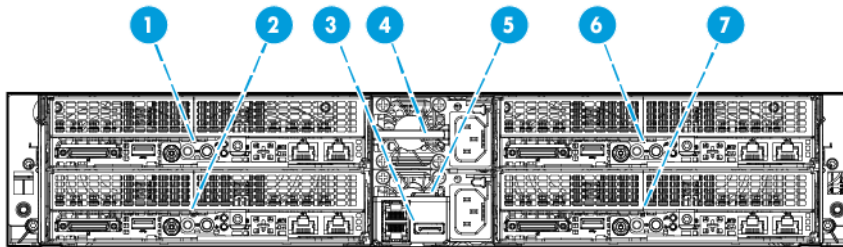

Item	Description
1	Node 4
2	Node 3
3	RCM module
4	Power Supply 2
5	Power Supply 1
6	Node 2
7	Node 1

- Two 2U nodes

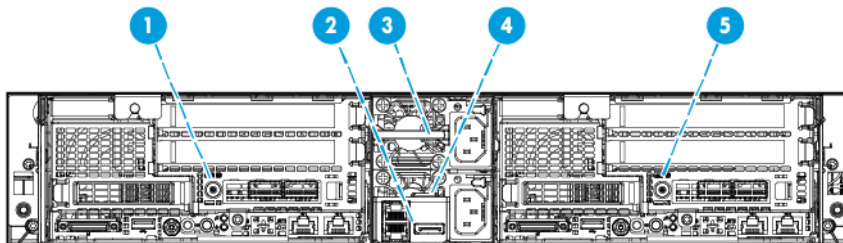

Item	Description
1	Node 3

Item	Description
2	RCM module
3	Power Supply 2
4	Power Supply 1
5	Node 1

## Chassis rear panel LEDs

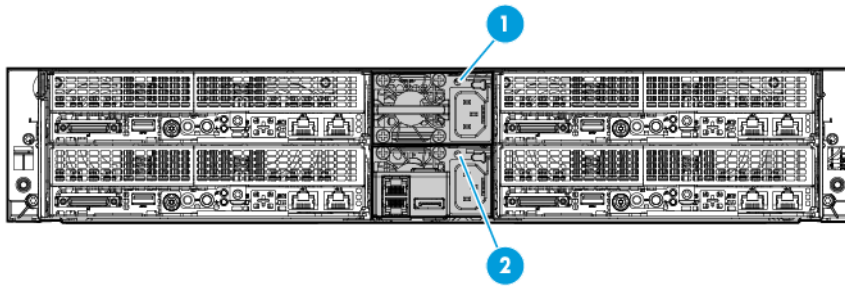

Item	Description	Status
1	Power supply 2 LED	Solid green = Normal Off = One or more of the following conditions exists: <ul style="list-style-type: none"> <li>• Power is unavailable</li> <li>• Power supply failed</li> <li>• Power supply is in standby mode</li> <li>• Power supply error</li> </ul>
2	Power supply 1 LED	Solid green = Normal Off = One or more of the following conditions exists: <ul style="list-style-type: none"> <li>• Power is unavailable</li> <li>• Power supply failed</li> <li>• Power supply is in standby mode</li> <li>• Power supply error</li> </ul>

# Node rear panel components

- 1U node rear panel components

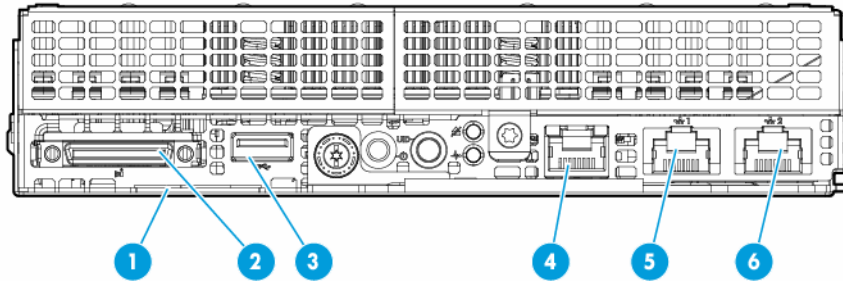

Item	Description
1	Node serial number and iLO label pull tab
2	SUV connector
3	USB 3.0 connector
4	Dedicated iLO port (optional)
5	NIC connector 1
6	NIC connector 2

- 2U node rear panel components

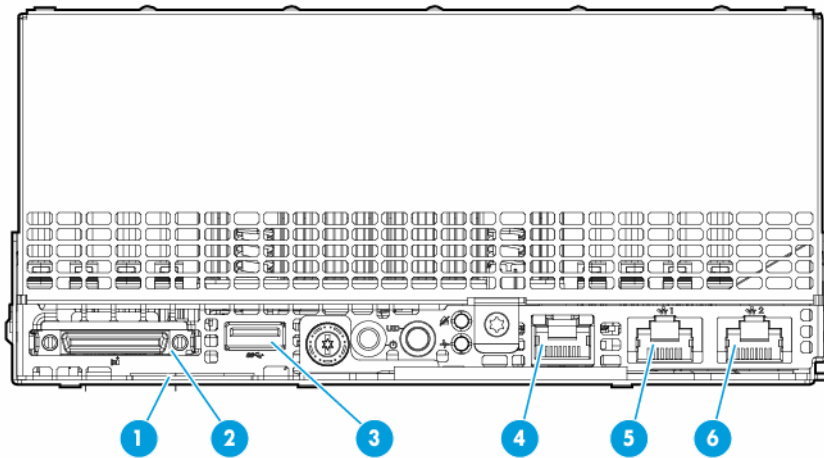

Item	Description
1	Node serial number and iLO label pull tab
2	SUV connector
3	USB 3.0 connector
4	Dedicated iLO port (optional)
5	NIC connector 1

Item	Description
6	NIC connector 2

## Node rear panel LEDs and buttons

- 1U node

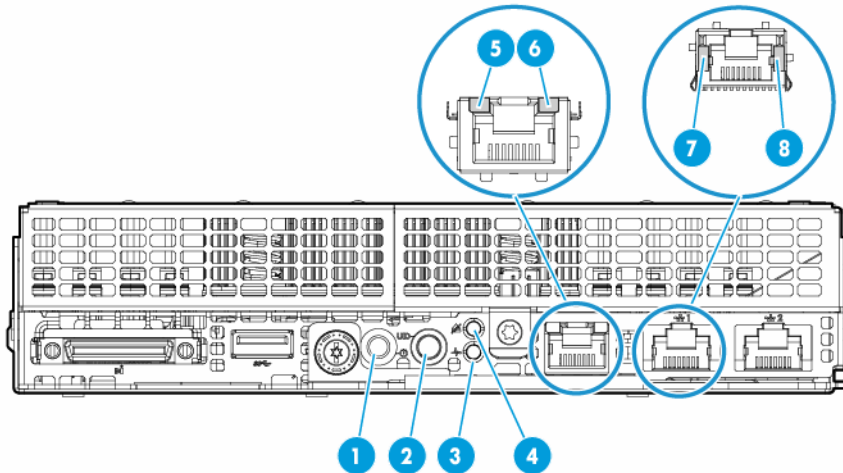

Item	Description	Status
1	Power button/LED*	Solid green = System on Flashing green (1 Hz/cycle per sec) = Performing power on sequence Solid amber = System in standby Off = No power present**
2	UID button/LED*	Solid blue = Activated Flashing blue: <ul style="list-style-type: none"> <li>• 1 Hz/cycle per sec = Remote management or firmware upgrade in progress</li> <li>• 4 Hz/cycle per sec = iLO manual soft reboot sequence initiated</li> <li>• 8 Hz/cycle per sec = iLO manual hard reboot sequence in progress</li> </ul> Off = Deactivated
3	Health LED*	Solid green = Normal Flashing green (1 Hz/cycle per sec) = iLO is rebooting Flashing amber = System degraded Flashing red (1 Hz/cycle per sec) = System critical†
4	Do not remove LED	Flashing white (1 Hz/cycle per sec) = Do not remove the node. Removing the node may terminate the current operation and cause data loss. Off = The node can be removed.

Item	Description	Status
5	iLO activity LED	Green or flashing green = Network activity Off = No network activity
6	iLO link LED	Green = Linked to network Off = No network connection
7	NIC link LED*	Green = Linked to network Off = No network connection
8	NIC activity LED*	Green or flashing green = Network activity Off = No network activity

\* When the LEDs described in this table flash simultaneously, a power fault has occurred. For more information, see "Power fault LEDs (on page 16)."

\*\* Facility power is not present, power cord is not attached, no power supplies are installed, power supply failure has occurred, or the front I/O cable is disconnected.

† If the health LED indicates a degraded or critical state, review the system IML or use iLO to review the system health status.

- 2U node

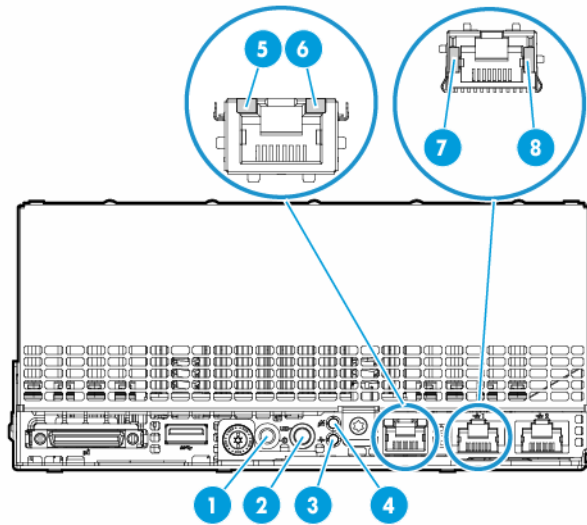

Item	Description	Status
1	Power button/LED*	Solid green = System on Flashing green = Performing power on sequence Solid amber = System in standby Off = No power present**
2	UID button/LED*	Solid blue = Activated Flashing blue: <ul style="list-style-type: none"> <li>• 1 Hz/cycle per sec = Remote management or firmware upgrade in progress</li> <li>• 4 Hz/cycle per sec = iLO manual soft reboot sequence initiated</li> <li>• 8 Hz/cycle per sec = iLO manual hard reboot sequence in progress</li> </ul> Off = Deactivated

Item	Description	Status
3	Health LED*	Solid green = Normal Flashing amber = System degraded Flashing red = System critical†
4	Do not remove LED	Flashing white (1 Hz/cycle per sec) = Do not remove the node. Removing the node may terminate the current operation and cause data loss. Off = The node can be removed.
5	iLO activity LED	Green or flashing green = Network activity Off = No network activity
6	iLO link LED	Green = Linked to network Off = No network connection
7	NIC link LED*	Green = Linked to network Off = No network connection
8	NIC activity LED*	Green or flashing green = Network activity Off = No network activity

\* When the LEDs described in this table flash simultaneously, a power fault has occurred. For more information, see "Power fault LEDs (on page 16)."

\*\* Facility power is not present, power cord is not attached, no power supplies are installed, power supply failure has occurred, or the front I/O cable is disconnected.

† If the health LED indicates a degraded or critical state, review the system IML or use iLO to review the system health status.

## Power fault LEDs

The following table provides a list of power fault LEDs, and the subsystems that are affected. Not all power faults are used by all servers.

Subsystem	LED behavior
System board	1 flash
Processor	2 flashes
Memory	3 flashes
Riser board PCIe slots	4 flashes
FlexibleLOM	5 flashes
Removable HP Flexible Smart Array controller/Smart SAS HBA controller	6 flashes
System board PCIe slots	7 flashes
Power backplane or storage backplane	8 flashes
Power supply	9 flashes

## System board components

---

**NOTE:** HP ProLiant XL170r and XL190r Gen9 Server Nodes share the same system board.

---



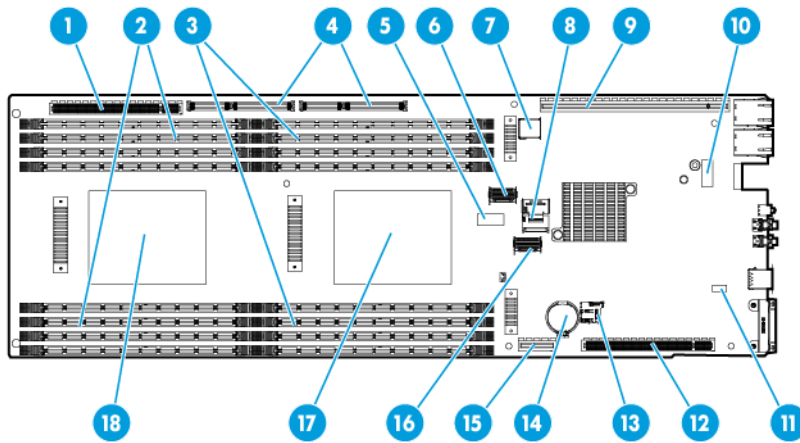

Item	Description
1	Bayonet board slot
2	DIMMs for processor 2
3	DIMMs for processor 1
4	PCIe x40 riser board connector*
5	System maintenance switch
6	Mini-SAS connector 1 (SATA x4)
7	Internal USB 3.0 connector
8	Mini-SAS connector 2 (SATA x4)
9	PCIe x24 riser board connector*
10	Dedicated iLO port connector
11	NMI header
12	PCIe x16 riser board connector*
13	microSD slot
14	System battery
15	M.2 SSD riser connector
16	TPM connector
17	Processor 1
18	Processor 2

\* For more information on the riser board slots supported by the onboard PCI riser connectors, see "PCIe riser board slot definitions (on page 27)."

## System maintenance switch

Position	Default	Function
S1	Off	Off = iLO security is enabled. On = iLO security is disabled.
S2	Off	Off = System configuration can be changed. On = System configuration is locked.
S3	Off	Reserved
S4	Off	Reserved

Position	Default	Function
S5	Off	Off = Power-on password is enabled. On = Power-on password is disabled.
S6	Off	Off = No function On = ROM reads system configuration as invalid.
S7	Off	Off = Set default boot mode to UEFI. On = Set default boot mode to legacy.
S8	—	Reserved
S9	—	Reserved
S10	—	Reserved
S11	—	Reserved
S12	—	Reserved

To access the redundant ROM, set S1, S5, and S6 to on.

When the system maintenance switch position 6 is set to the On position, the system is prepared to erase all system configuration settings from both CMOS and NVRAM.



**CAUTION:** Clearing CMOS and/or NVRAM deletes configuration information. Be sure to properly configure the server or data loss could occur.



**IMPORTANT:** Before using the S7 switch to change to Legacy BIOS Boot Mode, be sure the HP Dynamic Smart Array B140i Controller is disabled. Do not use the B140i controller when the server is in Legacy BIOS Boot Mode.

## NMI functionality

An NMI crash dump creates a crash dump log before resetting a system which is not responding.

Crash dump log analysis is an essential part of diagnosing reliability problems, such as failures of operating systems, device drivers, and applications. Many crashes freeze a system, and the only available action for administrators is to restart the system. Resetting the system erases any information which could support problem analysis, but the NMI feature preserves that information by performing a memory dump before a system reset.

To force the system to invoke the NMI handler and generate a crash dump log, do one of the following:

- Use the iLO Virtual NMI feature.
- Short the NMI header ("System board components" on page 16).

For more information, see the HP website (<http://www.hp.com/support/NMI>).

## DIMM slot locations

DIMM slots are numbered sequentially (1 through 8) for each processor. The supported AMP modes use the letter assignments for population guidelines.

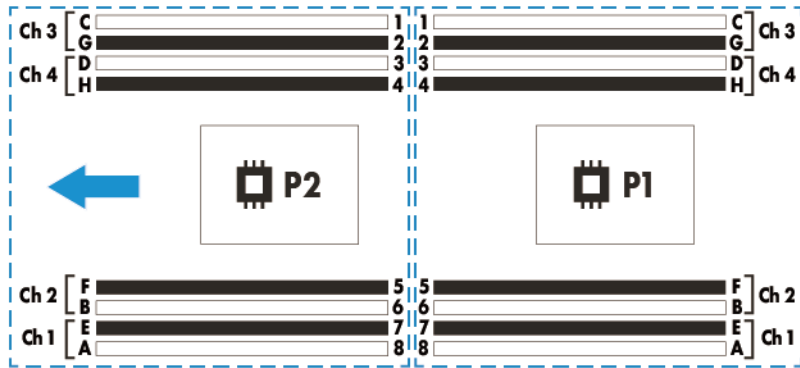

**NOTE:** The arrow indicates the front of the chassis.

## Fan locations

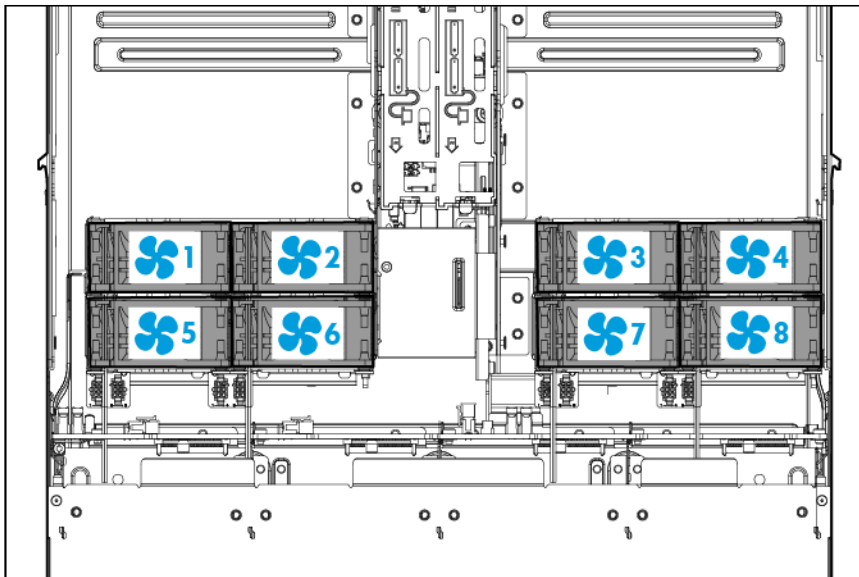

## Drive numbering



**CAUTION:** To prevent improper cooling and thermal damage, do not operate the chassis unless all bays are populated with a component or a blank.

**NOTE:** A storage cable option must be installed in a node for the node to correspond to drives in the chassis.

## HP Apollo r2200 Chassis drive numbering

One 1U node corresponds to a maximum of three low-profile LFF hot-plug drives:

- Node 1 corresponds to drives 1-1 through 1-3.
- Node 2 corresponds to drives 2-1 through 2-3.
- Node 3 corresponds to drives 3-1 through 3-3.
- Node 4 corresponds to drives 4-1 through 4-3.

One 2U node corresponds to a maximum of six low-profile LFF hot-plug drives:

- Node 1 corresponds to drives 1-1 through 2-3.
- Node 3 corresponds to drives 3-1 through 4-3.

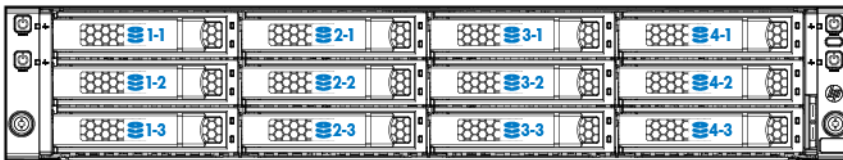

## HP Apollo r2600 Chassis drive numbering

One 1U node corresponds to a maximum of six SFF HP SmartDrives.

- Node 1 corresponds to drives 1-1 through 1-6.
- Node 2 corresponds to drives 2-1 through 2-6.
- Node 3 corresponds to drives 3-1 through 3-6.
- Node 4 corresponds to drives 4-1 through 4-6.

If a P840 Smart Array controller is installed, one 2U node corresponds to a maximum of twelve SFF HP SmartDrives.

- Node 1 corresponds to drives 1-1 through 2-6.

- Node 3 corresponds to drives 3-1 through 4-6.

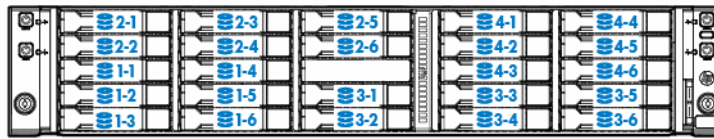

One 2U node corresponds to a maximum of eight SFF HP SmartDrives if using the HP Dynamic Smart Array B140i Controller, HP H240 Host Bus Adapter, or HP P440 Smart Array Controller.

- Node 1 corresponds to drives 1-1, 1-2, 1-4, 1-5, 2-1, 2-2, 2-3 and 2-5.
- Node 3 corresponds to drives 3-1, 3-2, 3-3, 3-5, 4-1, 4-2, 4-4 and 4-5.

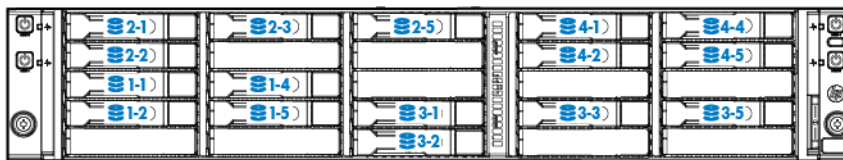

For more information on installing a storage controller, see "Controller options (on page 96)."

## M.2 SATA SSD bay numbering

- Bay 9



- Bay 10

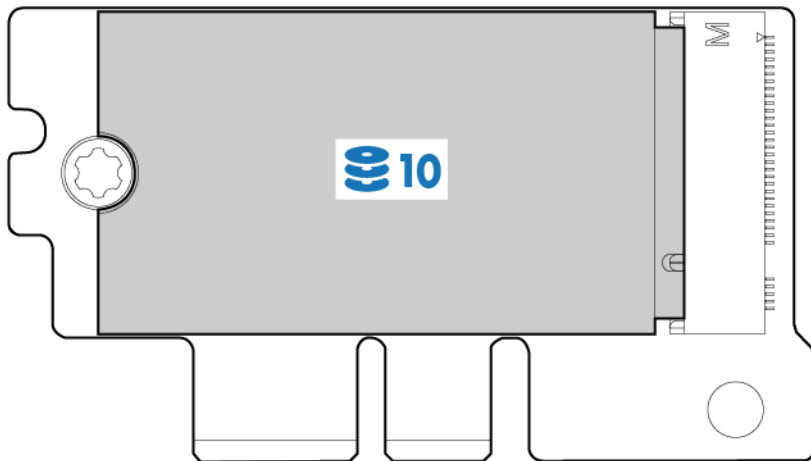

## Hot-plug drive LED definitions

### HP SmartDrive LED definitions

HP SmartDrives are the latest HP drive technology, and they are supported beginning with ProLiant Gen8 servers and server blades. The HP SmartDrive is not supported on earlier generation servers and server blades. Identify an HP SmartDrive by its carrier, shown in the following illustration.

When a drive is configured as a part of an array and connected to a powered-up controller, the drive LEDs indicate the condition of the drive.

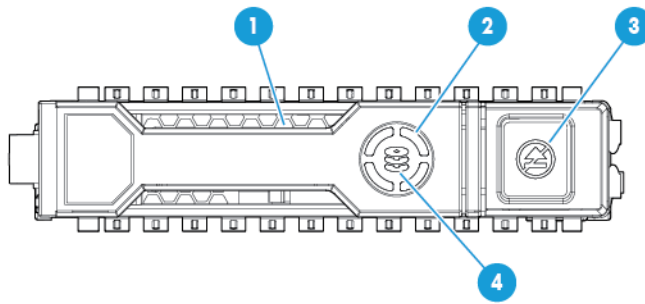

Item	LED	Status	Definition
1	Locate	Solid blue	The drive is being identified by a host application.
		Flashing blue	The drive carrier firmware is being updated or requires an update.
2	Activity ring	Rotating green	Drive activity
		Off	No drive activity
3	Do not remove	Solid white	Do not remove the drive. Removing the drive causes one or more of the logical drives to fail.
		Off	Removing the drive does not cause a logical drive to fail.
4	Drive status	Solid green	The drive is a member of one or more logical drives.
		Flashing green	The drive is rebuilding or performing a RAID migration, strip size migration, capacity expansion, or logical drive extension, or is erasing.
		Flashing amber/green	The drive is a member of one or more logical drives and predicts the drive will fail.
		Flashing amber	The drive is not configured and predicts the drive will fail.
		Solid amber	The drive has failed.
		Off	The drive is not configured by a RAID controller.

The blue Locate LED is behind the release lever and is visible when illuminated.



**IMPORTANT:** The HP Dynamic Smart Array B140i Controller is only available in UEFI Boot Mode. It cannot be enabled in Legacy BIOS Boot Mode. If the B140i controller is disabled, drives connected to the system board Mini-SAS connectors operate in AHCI or Legacy mode. Under this condition:

- The drives cannot be a part of a hardware RAID or a logical drive.
- The Locate, Drive status, and Do not remove LEDs of the affected drives are disabled.

Use BIOS/Platform Configuration (RBSU) in the UEFI System Utilities ("[HP UEFI System Utilities](#)" on page 149) to enable or disable the B140i controller (System Configuration → BIOS/Platform Configuration (RBSU) → System Options → SATA Controller Options → Embedded SATA Configuration).

# Low-profile LFF hot-plug drive LED definitions

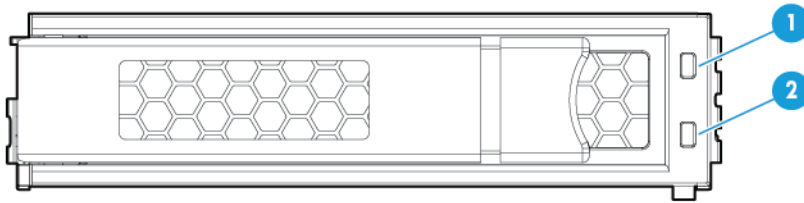

Item	Definition
1	Fault/UID (amber/blue)
2	Online/Activity (green)

Online/activity LED (green)	Fault/UID LED (amber/blue)	Definition
On, off, or flashing	Alternating amber and blue	The drive has failed, or a predictive failure alert has been received for this drive; it also has been selected by a management application.
On, off, or flashing	Steadily blue	The drive is operating normally, and it has been selected by a management application.
On	Amber, Flashing (1 Hz)	A predictive failure alert has been received for this drive. Replace the drive as soon as possible.
On	Off	The drive is online, but it is not active currently.
Flashing (1 Hz)	Amber, Flashing (1 Hz)	Do not remove the drive. Removing a drive may terminate the current operation and cause data loss. The drive is part of an array that is undergoing capacity expansion or stripe migration, but a predictive failure alert has been received for this drive. To minimize the risk of data loss, do not replace the drive until the expansion or migration is complete.
Flashing (1 Hz)	Off	Do not remove the drive. Removing a drive may terminate the current operation and cause data loss. The drive is rebuilding, erasing, or it is part of an array that is undergoing capacity expansion or stripe migration.
Flashing (4 Hz)	Amber, Flashing (1 Hz)	The drive is active, but a predictive failure alert has been received for this drive. Replace the drive as soon as possible.
Flashing (4 Hz)	Off	The drive is active, and it is operating normally.
Off	Steadily amber	A critical fault condition has been identified for this drive, and the controller has placed it offline. Replace the drive as soon as possible.
Off	Amber, Flashing (1 Hz)	A predictive failure alert has been received for this drive. Replace the drive as soon as possible.
Off	Off	The drive is offline, a spare, or not configured as part of an array.



# RCM module components

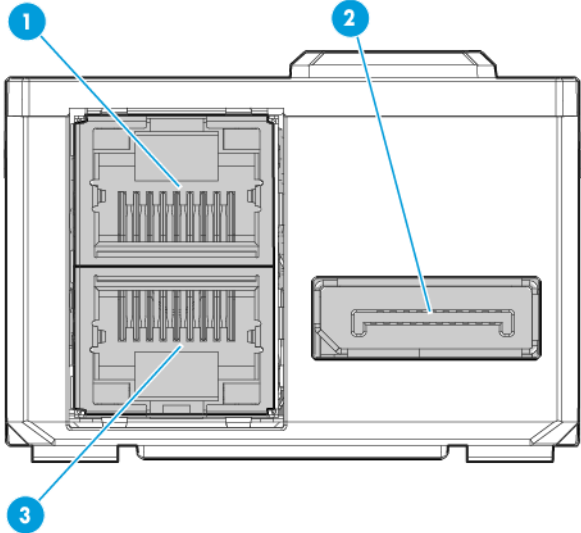

Item	Description
1	iLO connector
2	HP APM 2.0 connector
3	iLO connector



**IMPORTANT:** Use either the HP APM port or an iLO port to connect to a network. Having both ports connected at the same time results in a loopback condition.



**IMPORTANT:** Do not connect both iLO ports to the network at the same time. Only one iLO port can be connected to the network, while the other iLO port can be used only as a connection to a second enclosure. Having both ports connected at the same time results in a loopback condition.

# RCM module LEDs

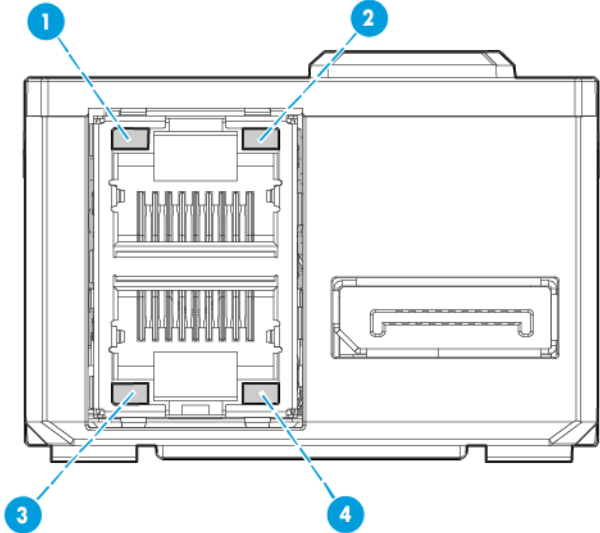

Item	Description
1	iLO activity LED Green or flashing green = Network activity Off = No network activity
2	iLO link LED Green = Linked to network Off = No network connection
3	iLO link LED Green = Linked to network Off = No network connection
4	iLO activity LED Green or flashing green = Network activity Off = No network activity

# PCIe riser board slot definitions

- Single-slot left PCI riser cage assembly

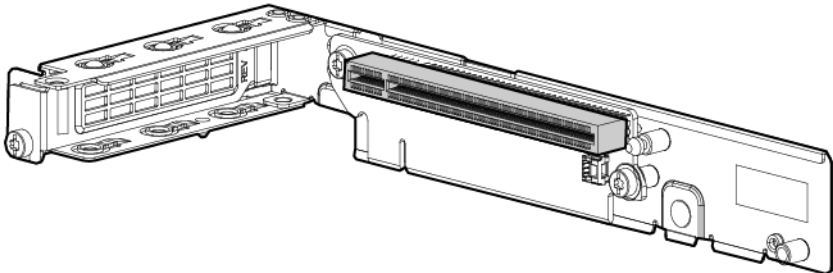

Form factor	Slot number	Slot description
Low-profile PCIe card	1	PCIe3 x16 (16, 8, 4, 1) for Processor 1

- Single-slot 1U node right PCI riser cage assembly

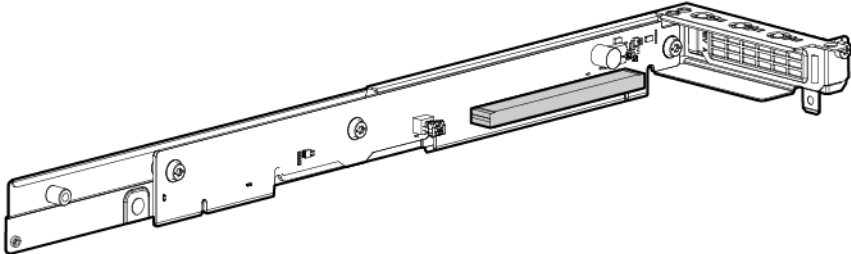

Form factor	Slot number	Slot description
Low-profile PCIe NIC card	2	PCIe3 x16 (16, 8, 4, 1) for Processor 2

- FlexibleLOM 1U node riser cage assembly

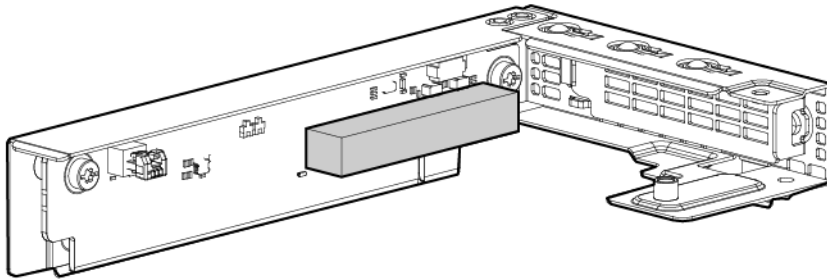

Form factor	Slot number	Slot description
FlexibleLOM	FlexibleLOM slot	PCIe3 x8 for Processor 1

- Single-slot 2U node PCI riser cage assembly

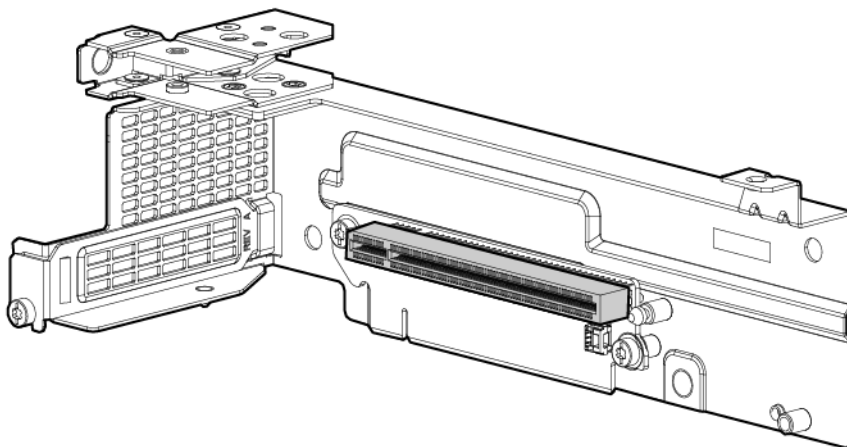

Form factor	Slot number	Slot description
Low-profile PCIe card	1	PCIe3 x16 (16, 8, 4, 1) for Processor 1

- FlexibleLOM 2U node riser cage assembly

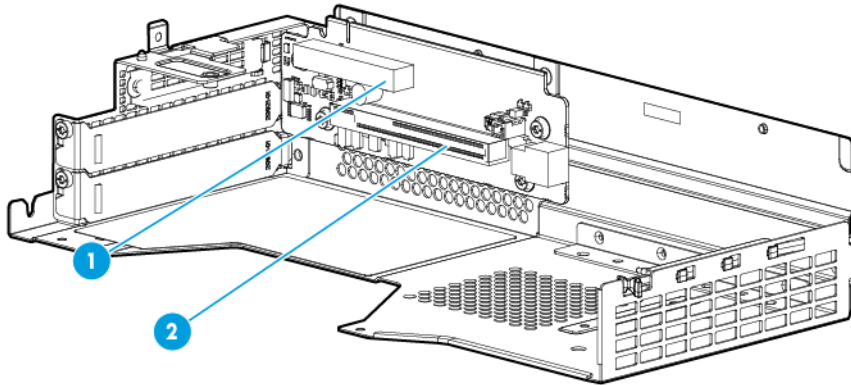

Item	Form factor	Slot number	Slot description
1	FlexibleLOM	FlexibleLOM slot	PCIe3 x8 for Processor 1
2	Storage controller or graphic card	2	PCIe3 x16 (16, 8, 4, 1) for Processor 1

- Three-slot PCI riser cage assembly

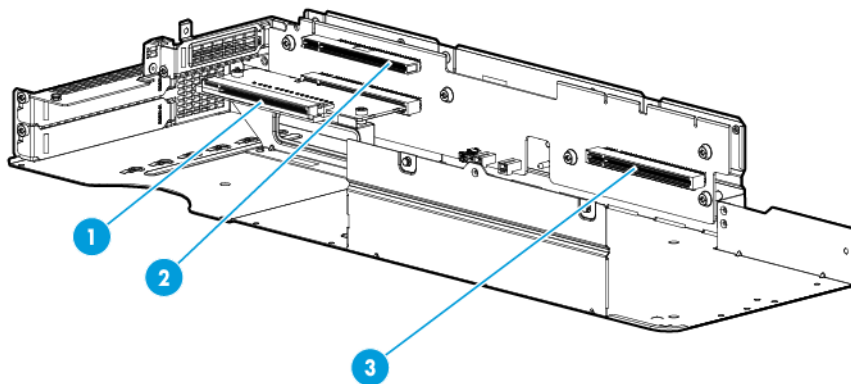

Item	Form factor	Slot number	Slot description
1	Storage controller or graphic card	3	PCIe3 x16 (16, 8, 4, 1) for Processor 1
2	Low-profile PCIe NIC card	2	PCIe3 x16 (16, 8, 4, 1) for Processor 2
3	Graphic card	4	PCIe3 x16 (16, 8, 4, 1) for Processor 2

- Three-slot GPU-direct PCI riser cage assembly

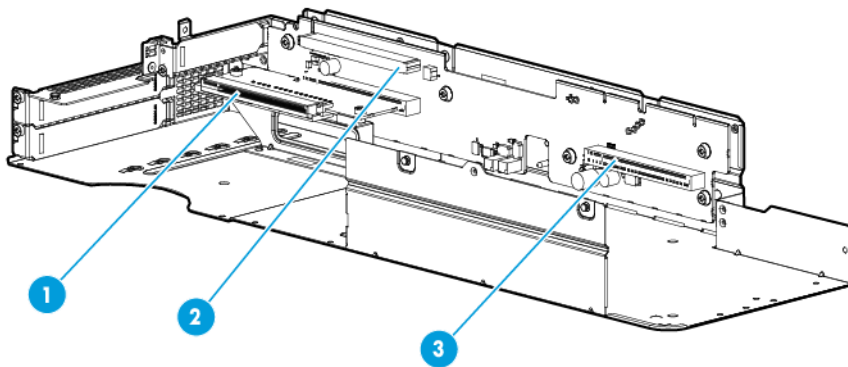

Item	Form factor	Slot number	Slot description
1	Storage controller or graphic card	3	PCIe3 x16 (16, 8, 4, 1) for Processor 2
2	Low-profile PCIe NIC card	2	PCIe3 x16 (16, 8, 4, 1) for Processor 2
3	Graphic card	4	PCIe3 x16 (16, 8, 4, 1) for Processor 2

---

# Operations

## Power up the nodes

The SL/XL Chassis Firmware initiates an automatic power-up sequence when the nodes are installed. If the default setting is changed, use one of the following methods to power up each node:

- Use a virtual power button selection through iLO.
- Press and release the Power On/Standby button.

When the node goes from the standby mode to the full power mode, the node power LED changes from amber to green.

For more information about iLO, see the HP website (<http://www.hp.com/go/ilo>).

## Power down the system



---

**IMPORTANT:** When the nodes are in standby mode, auxiliary power is still being provided to the system.

---

1. Power down the node (on page 31).
2. Disconnect the power cords from the power supplies.

## Power down the node

Before powering down the node for any upgrade or maintenance procedures, perform a backup of critical server data and programs.



---

**IMPORTANT:** When the node is in standby mode, auxiliary power is still being provided to the system.

---

To power down the node, use one of the following methods:

- Press and release the Power On/Standby button.  
This method initiates a controlled shutdown of applications and the OS before the node enters standby mode.
- Press and hold the Power On/Standby button for more than 4 seconds to force the node to enter standby mode.  
This method forces the node to enter standby mode without properly exiting applications and the OS. If an application stops responding, you can use this method to force a shutdown.
- Use a virtual power button selection through iLO.  
This method initiates a controlled remote shutdown of applications and the OS before the node enters standby mode.

Before proceeding, verify the node is in standby mode by observing that the system power LED is amber.

# Remove the node from the chassis

**CAUTION:** To avoid damage to the node, always support the bottom of the node when removing it from the chassis.

1. Power down the node (on page 31).
2. Disconnect all peripheral cables from the node.
3. Remove the node from the chassis:
  - a. Loosen the thumbscrew.
  - b. Pull back the handle and remove the node.

1U node

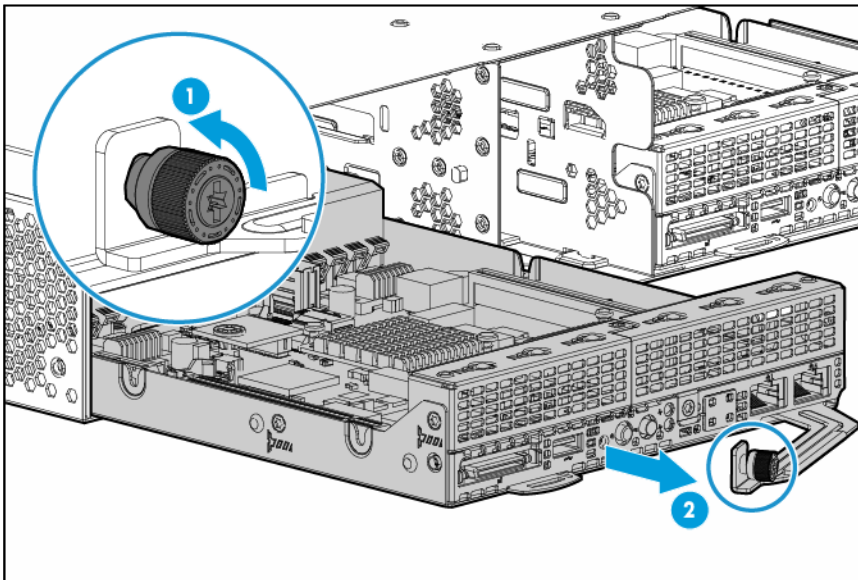

2U node

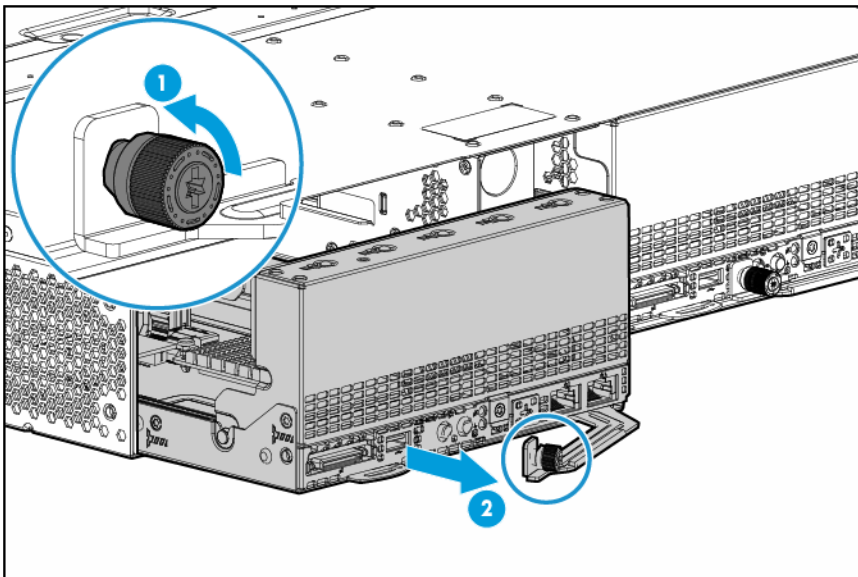





**CAUTION:** To avoid damage to the device, do not use the removal handle to carry it.

4. Place the node on a flat, level surface.

## Remove the RCM module

To remove the component:

1. Power down the system (on page 31).
2. Access the product rear panel.
3. Disconnect all cables from the RCM module.
4. Remove the RCM module.

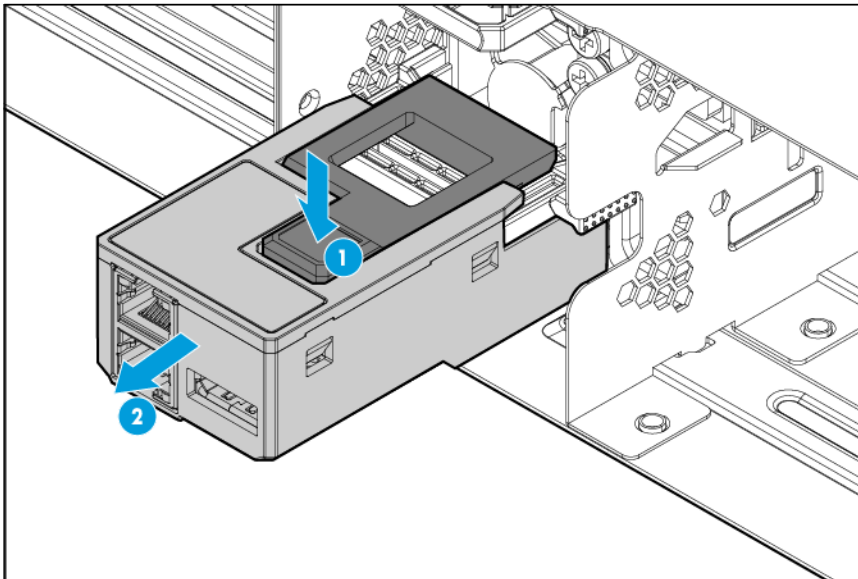

## Remove the power supply

To remove the component:

1. Power down the system (on page 31).
2. Access the product rear panel.
3. If installed, remove the RCM module (on page 33).
4. Release the power cord from the relief strap.
5. Remove all power:
  - a. Disconnect the power cord from the power source.
  - b. Disconnect the power cord from the chassis.

6. Remove the power supply.

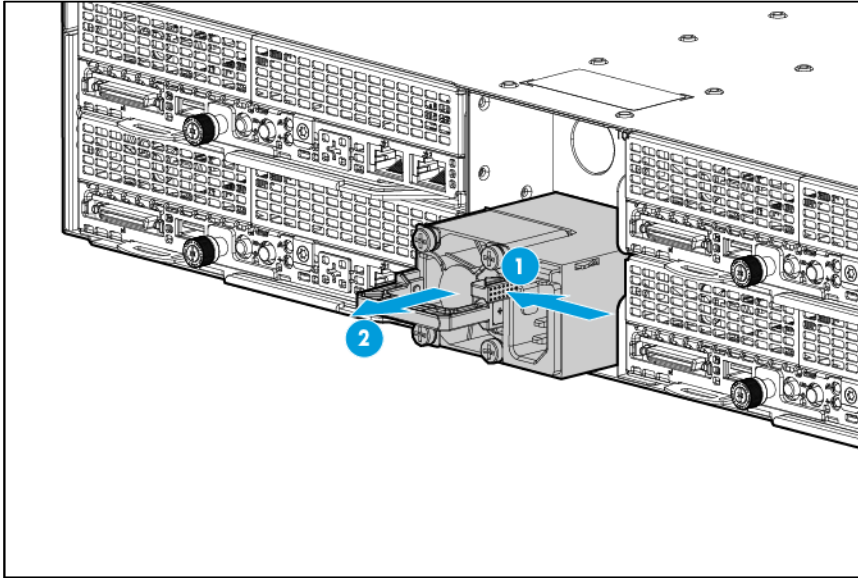

## Remove the chassis from the rack

**⚠ WARNING:** The chassis is very heavy. To reduce the risk of personal injury or damage to the equipment:

- Observe local occupational health and safety requirements and guidelines for manual material handling.
- Remove all installed components from the chassis before installing or moving the chassis.
- Use caution and get help to lift and stabilize the chassis during installation or removal, especially when the chassis is not fastened to the rack.

**⚠ WARNING:** To reduce the risk of personal injury or damage to the equipment, you must adequately support the chassis during installation and removal.

**⚠ WARNING:** Always use at least two people to lift the chassis into the rack. If the chassis is being loaded into the rack above chest level, a third person must assist with aligning the chassis with the rails while the other two people support the weight of the chassis.

1. Power down the system (on page 31).
2. Disconnect all peripheral cables from the nodes and chassis.

**📝 IMPORTANT:** Label the drives before removing them. The drives must be returned to their original locations.

3. Remove all nodes from the chassis ("Remove the node from the chassis" on page 32).
4. If installed, remove the security bezel (on page 35).
5. Remove all drives ("Removing the drive" on page 35).
6. If installed, remove the RCM module (on page 33).
7. Remove all power supplies ("Remove the power supply" on page 33).

- Loosen the thumbscrews and extend the chassis from the rack.

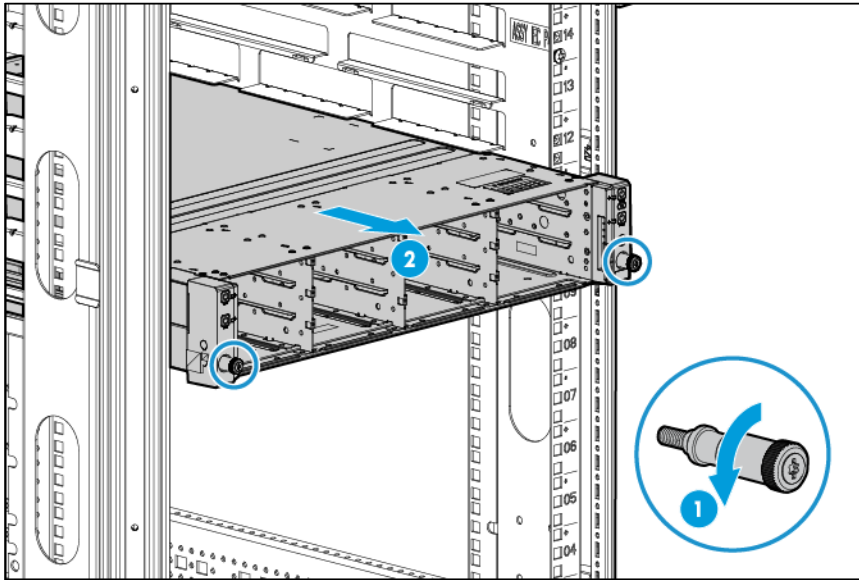

- Remove the chassis from the rack.  
For more information, see the documentation that ships with the rack mounting option.
- Place the chassis on a flat surface.

## Remove the security bezel

To access the front panel components, unlock and then remove the security bezel.

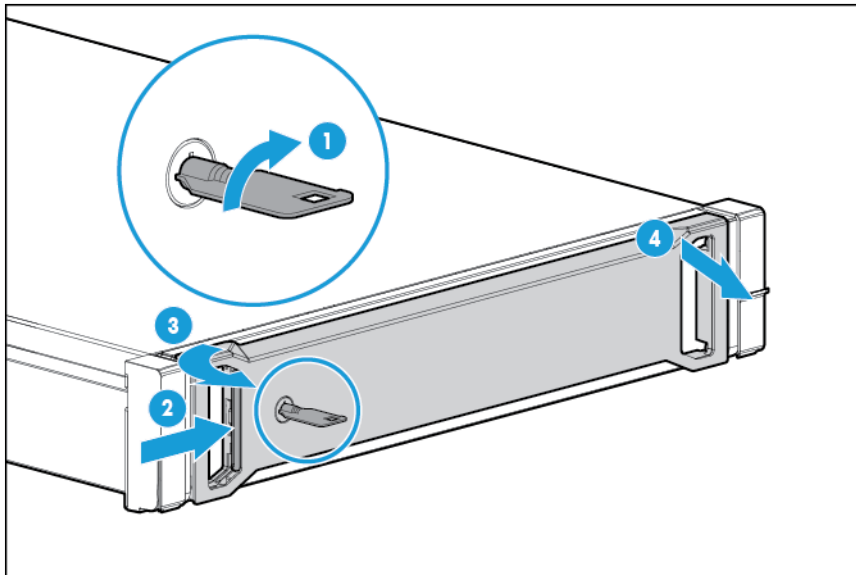

## Removing the drive



**CAUTION:** For proper cooling, do not operate the node without the access panel, baffles, expansion slot covers, or blanks installed. If the server supports hot-plug components, minimize the amount of time the access panel is open.

1. If installed, remove the security bezel (on page 35).
2. Remove the drive:
  - o SFF HP SmartDrive

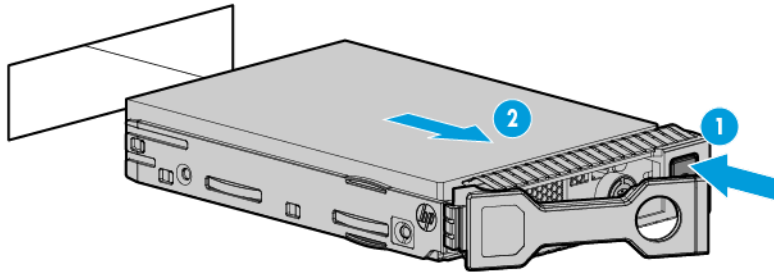

- o Low-profile LFF hot-plug drive

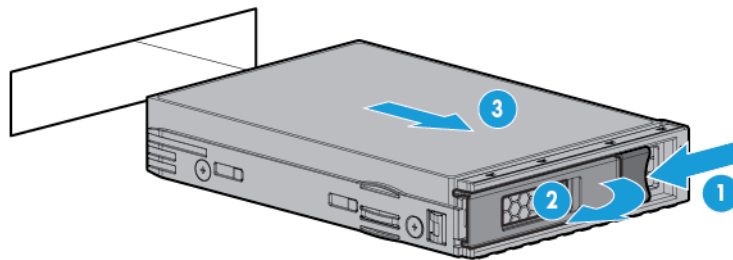

## Remove the chassis access panel

1. Power down the system (on page 31).
2. Disconnect all peripheral cables from the nodes and chassis.
3. Remove all nodes from the chassis ("[Remove the node from the chassis](#)" on page 32).
4. If installed, remove the security bezel (on page 35).
5. Remove all drives ("[Removing the drive](#)" on page 35).
6. If installed, remove the RCM module (on page 33).
7. Remove all power supplies ("[Remove the power supply](#)" on page 33).
8. Remove the chassis from the rack (on page 34).
9. Unlock the access panel latch using the T-15 Torx screwdriver and release the access panel latch.
10. Slide the access panel back about 1.5 cm (0.5 in).

11. Lift and remove the access panel.

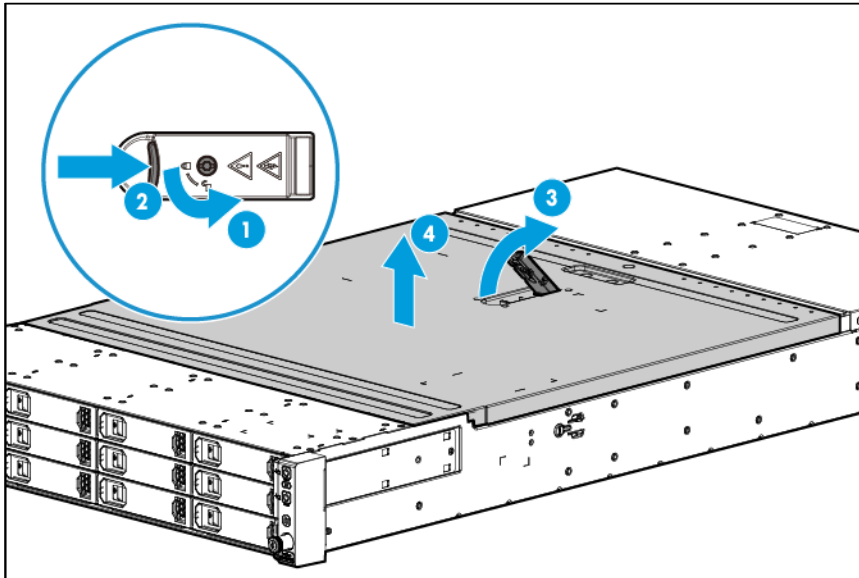

## Install the chassis access panel

1. Install the chassis access panel.
  - a. Place the access panel and align the pin on the chassis, and slide it towards the front of the server.
  - b. Lock the access panel latch using the T-15 Torx screwdriver.

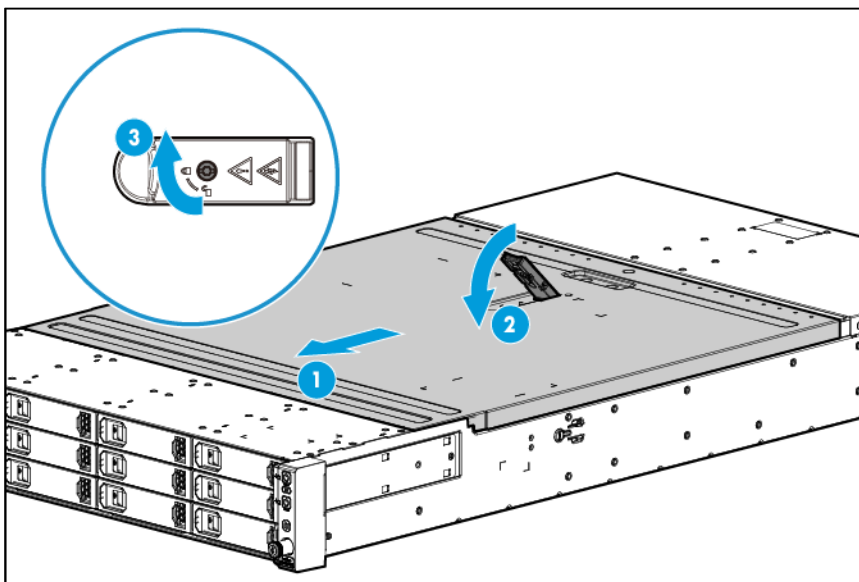

2. Install the chassis into the rack ("[Installing the chassis into the rack](#)" on page 59).
3. Install all nodes, drives and power supplies ("[Chassis component installation](#)" on page 60).
4. If removed, install the security bezel ("[Security bezel option](#)" on page 64).
5. If removed, install the RCM module ("[Rack control management \(RCM\) module](#)" on page 67).
6. Connect all peripheral cables to the nodes and chassis.
7. Power up the nodes (on page 31).

## Remove the 1U left rear I/O blank

1. Power down the node (on page 31).
2. Disconnect all peripheral cables from the node.
3. Remove the node from the chassis (on page 32).
4. Place the node on a flat, level surface.
5. Remove the 1U left rear I/O blank.

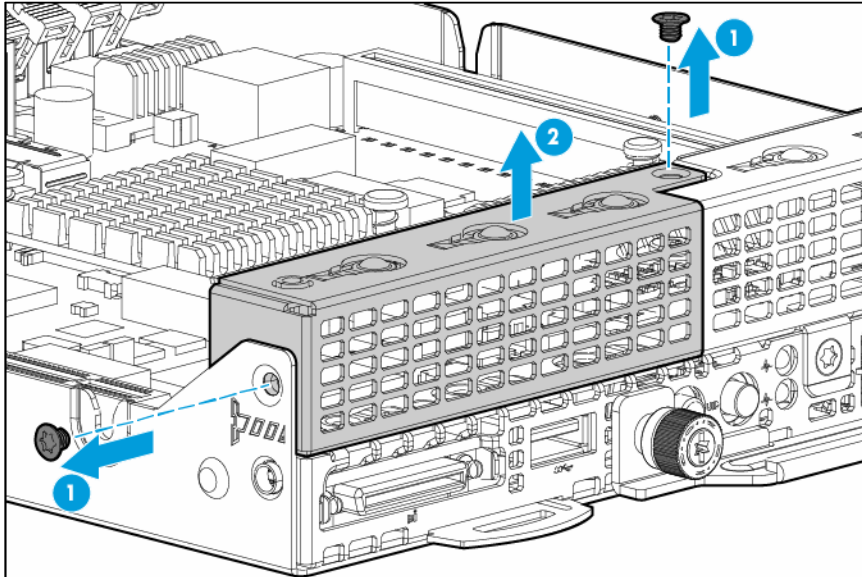

## Install the 1U left rear I/O blank

1. Install the 1U left rear I/O blank.

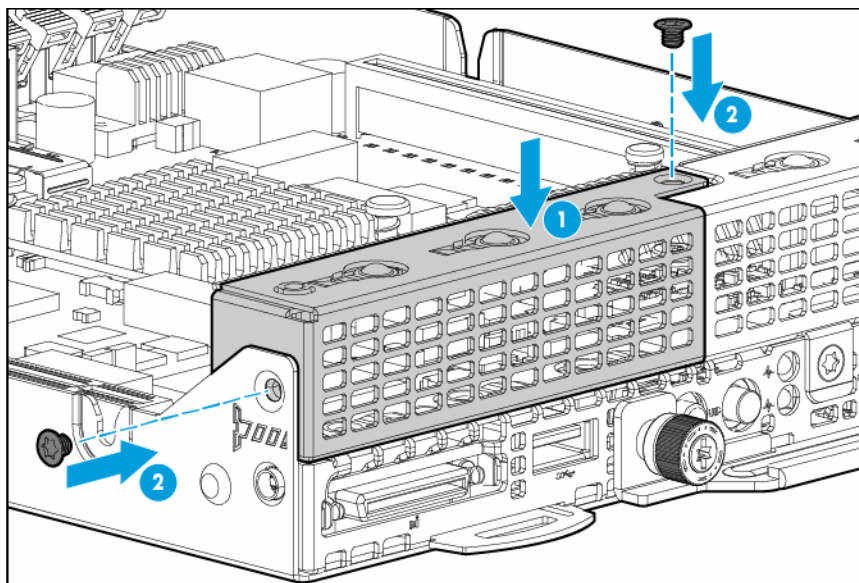

2. Install the node into the chassis.
3. Connect all peripheral cable to the node.

4. Power up the node ("[Power up the nodes](#)" on page 31).

## Remove the 1U right rear I/O blank

1. Power down the node (on page 31).
2. Disconnect all peripheral cables from the node.
3. Remove the node from the chassis (on page 32).
4. Place the node on a flat, level surface.
5. Do one of the following:
  - o Remove the 1U left rear I/O blank (on page 38).
  - o Remove the single-slot left PCI riser cage assembly (on page 48).
6. Remove the 1U right rear I/O blank.

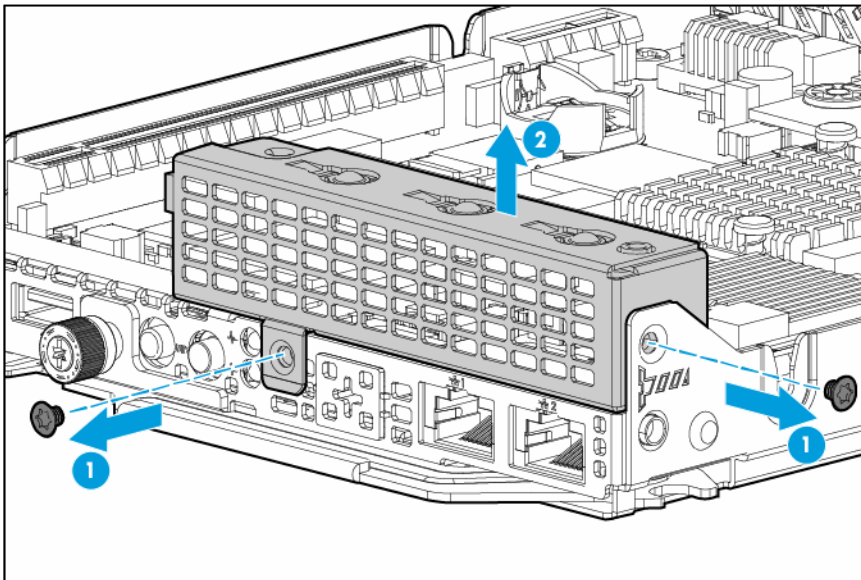

# Install the 1U right rear I/O blank

1. Install the 1U right rear I/O blank.

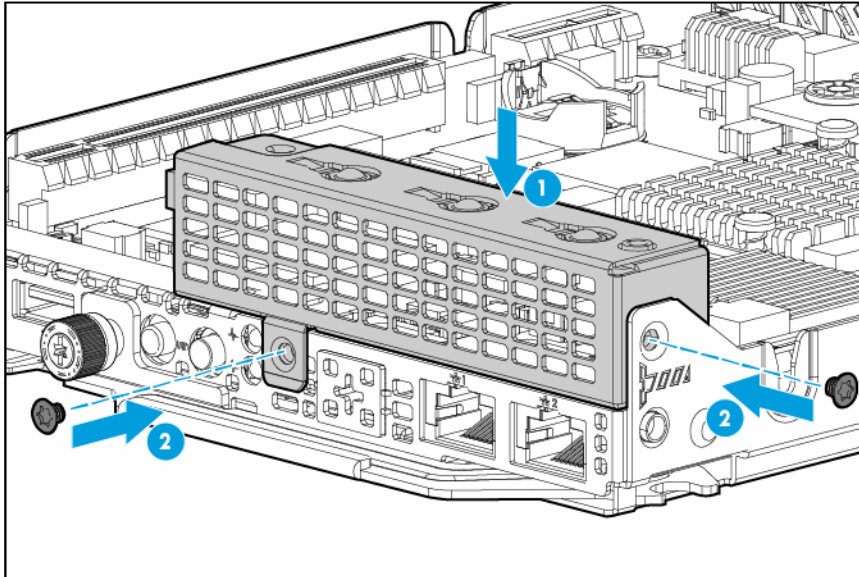

2. Do one of the following:
  - Install the 1U left rear I/O blank (on page 38).
  - Install the single-slot left PCI riser cage assembly ("[Single-slot left PCI riser cage assembly option](#)" on page 85).
3. Install the node into the chassis ("[Installing a node into the chassis](#)" on page 60).
4. Connect all peripheral cables to the node.
5. Power up the node ("[Power up the nodes](#)" on page 31).

# Remove the 2U rear I/O blank

1. Power down the node (on page 31).
2. Disconnect all peripheral cables from the node.
3. Remove the node from the chassis (on page 32).
4. Place the node on a flat, level surface.



5. Remove the 2U rear I/O blank.

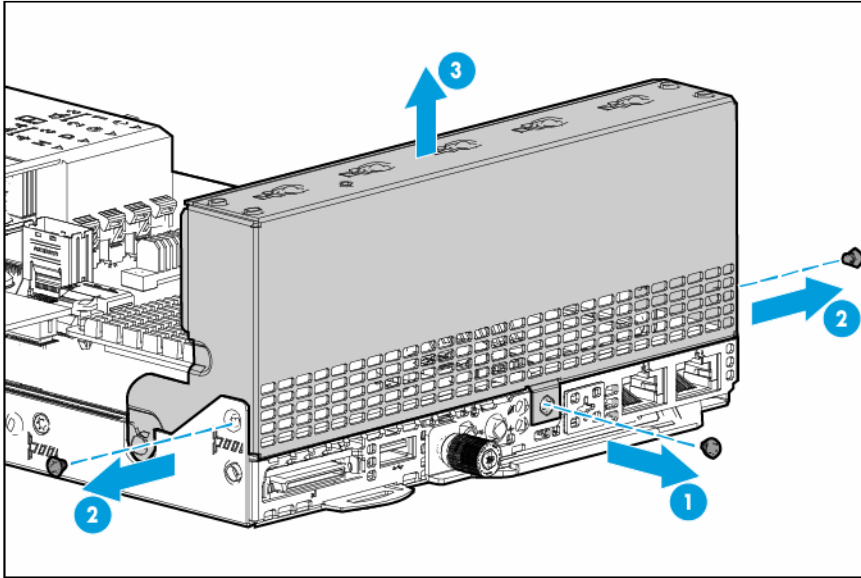

## Install the 2U node rear I/O blank

1. Install the 2U rear I/O blank.

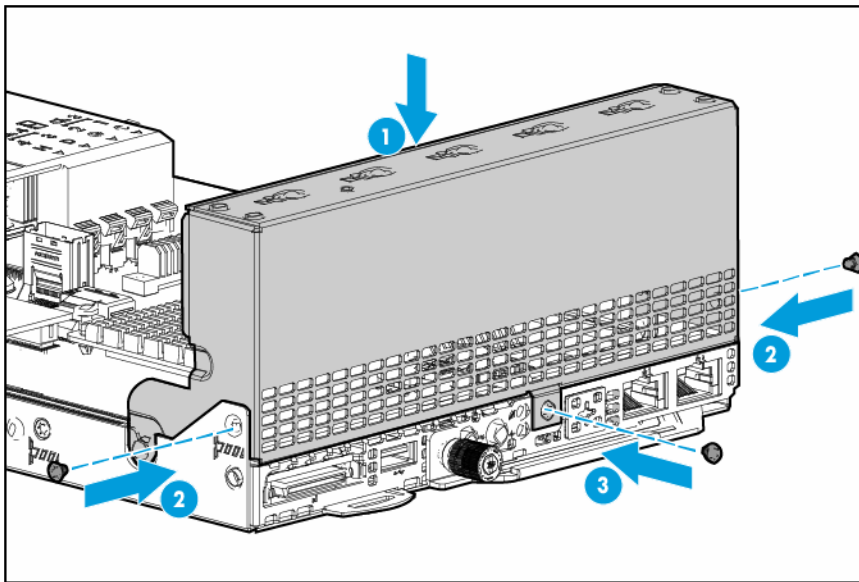

2. Install the node into the chassis ("[Installing a node into the chassis](#)" on page 60).
3. Connect all peripheral cables to the node.
4. Power up the node ("[Power up the nodes](#)" on page 31).

## Remove the air baffle

1. Power down the node (on page 31).
2. Disconnect all peripheral cables from the node.

3. Remove the node from the chassis (on page 32).
4. Place the node on a flat, level surface.
5. If installed in a 2U node, remove the FlexibleLOM 2U node riser cage assembly ("FlexibleLOM 2U node riser cage assembly" on page 52).
6. If installed in a 2U node, remove the three-slot PCI riser cage assembly ("Three-slot PCI riser cage assemblies" on page 53).
7. Remove the air baffle:
  - o 1U air baffle

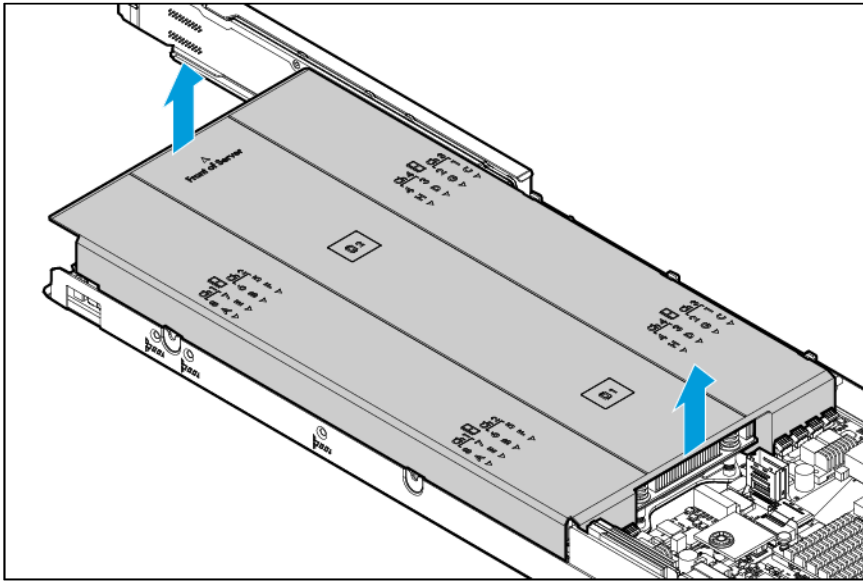

- o 2U air baffle

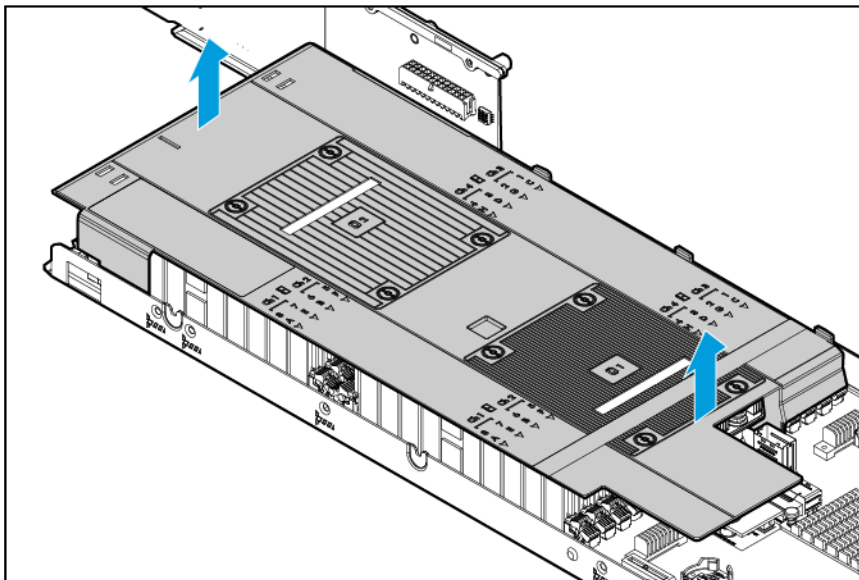

## Install the air baffle

1. Install the air baffle:

- 1U air baffle

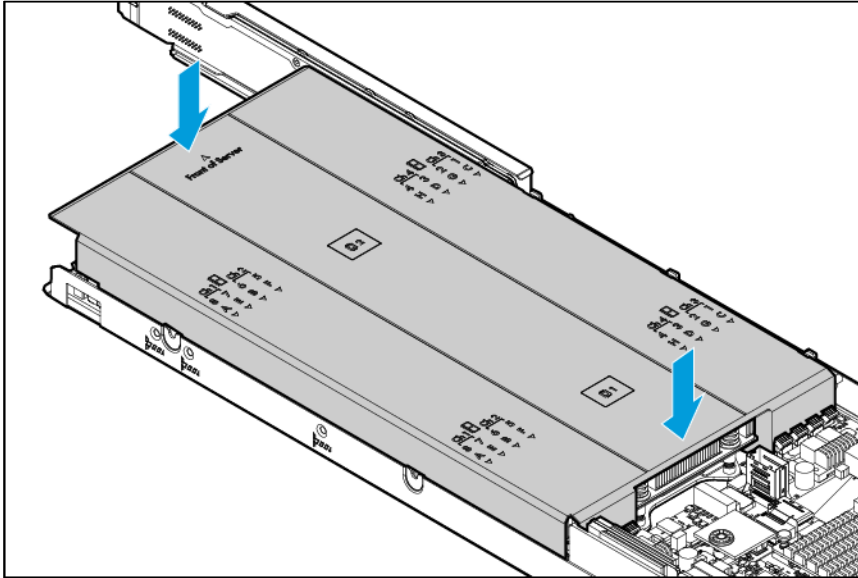

- 2U air baffle

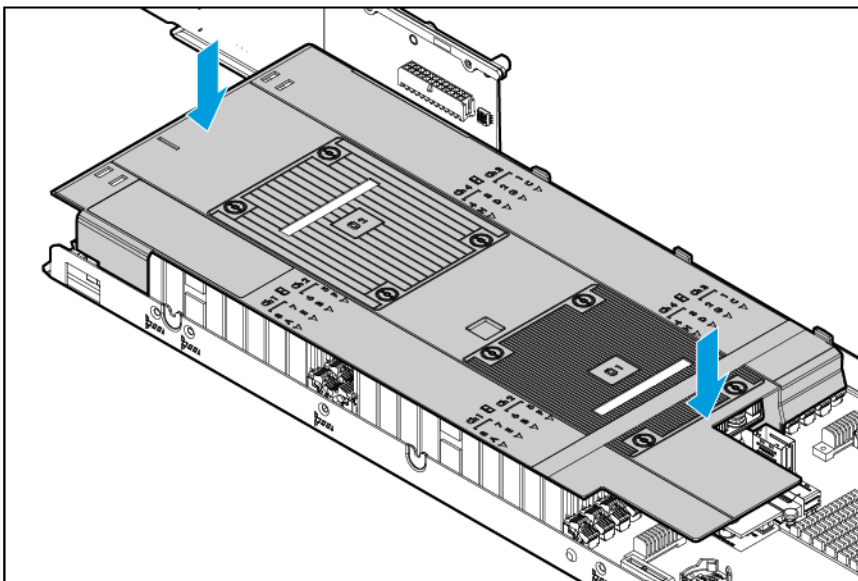

2. Install any removed PCI riser cage assemblies ("[PCI riser cage assembly options](#)" on page 84).
3. Install the node into the chassis ("[Installing a node into the chassis](#)" on page 60).
4. Connect all peripheral cables to the node.
5. Power up the node ("[Power up the nodes](#)" on page 31).

## Remove the bayonet board assembly

1. Power down the node (on page 31).
2. Disconnect all peripheral cables from the node.
3. Remove the node from the chassis (on page 32).
4. Place the node on a flat, level surface.

5. If installed in a 2U node, remove the FlexibleLOM 2U node riser cage assembly ("[FlexibleLOM 2U node riser cage assembly](#)" on page 52).
6. If installed in a 2U node, remove the three-slot PCI riser cage assembly ("[Three-slot PCI riser cage assemblies](#)" on page 53).
7. If a graphic card/ coprocessor power cable is installed, disconnect it from the bayonet board.
8. If a B140i SATA cable is installed, disconnect it from the connectors on the system board.
9. Remove the bayonet board assembly from the node.
  - o 1U bayonet board assembly

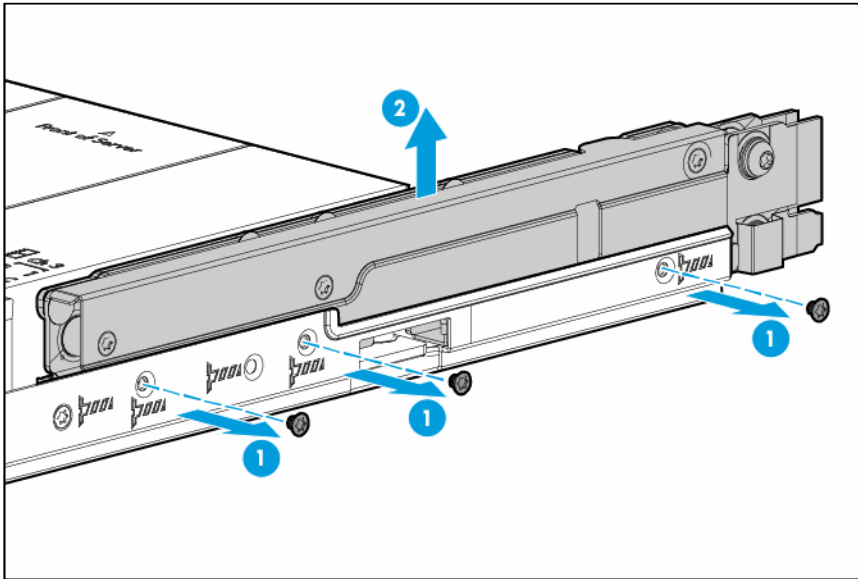

- o 2U bayonet board assembly

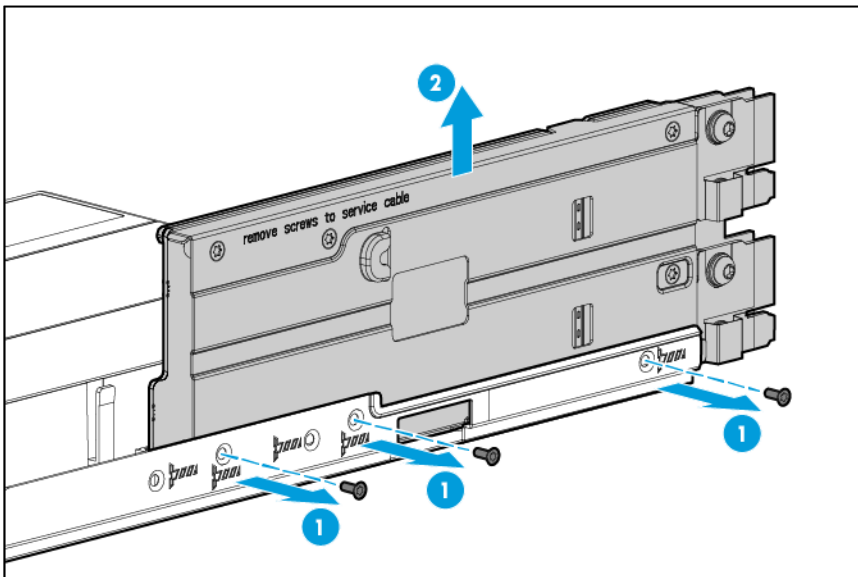

## Install the bayonet board assembly

1. Install the bayonet board assembly into the node:

- 1U bayonet board assembly

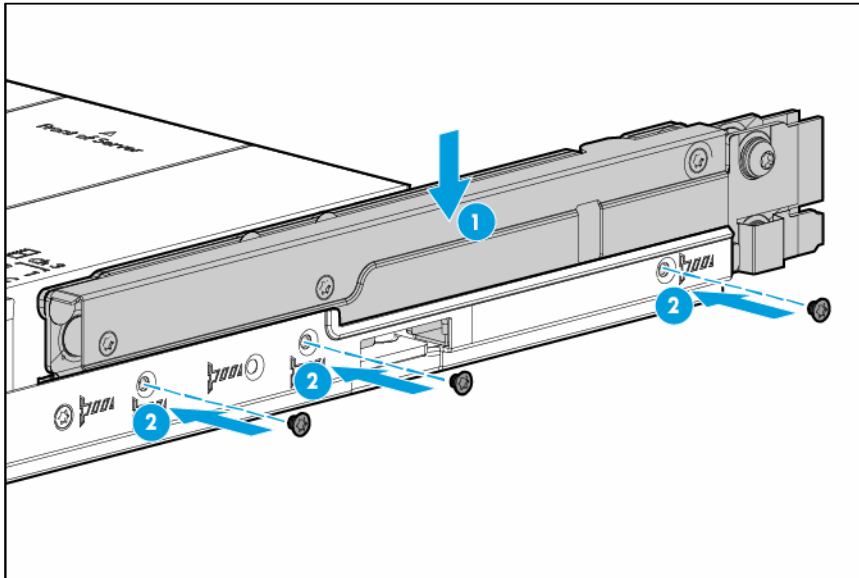

- 2U bayonet board assembly

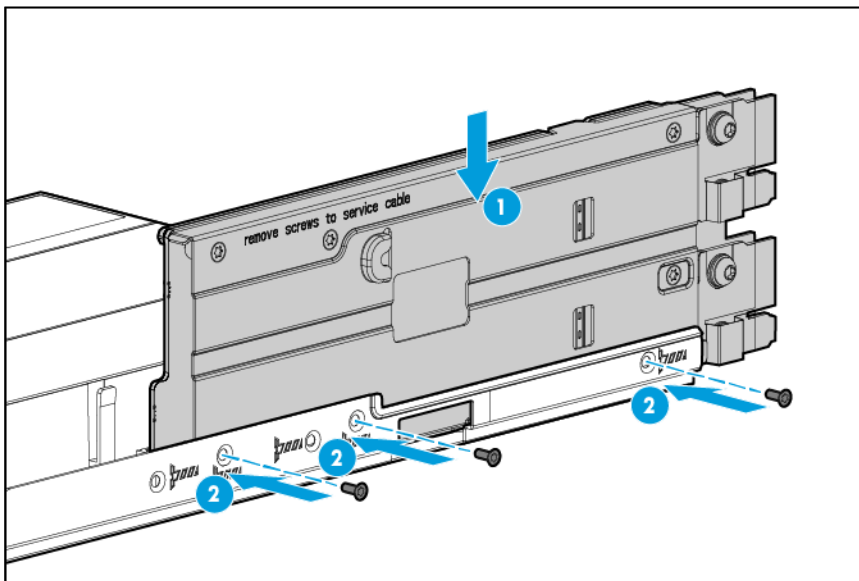

2. If any SATA or Mini-SAS cables are installed, secure the cables under the thin plastic covers along the side of the node tray.
3. If removed, connect the B140i SATA cable to the connectors on the system board ("[B140i 1U node SATA cable](#)" on page 78, "[B140i 2U node SATA cable](#)" on page 79).
4. If a graphic card/ coprocessor power cable was removed, connect it to the bayonet board.
5. If removed, install the FlexibleLOM 2U node riser cage assembly ("[FlexibleLOM 2U node riser cage assembly option](#)" on page 92).
6. If removed, install the three-slot PCI riser cage assembly ("[Three-slot PCI riser cage assembly options](#)" on page 93).
7. Install the node into the chassis ("[Installing a node into the chassis](#)" on page 60).
8. Connect all peripheral cables to the node.

9. Power up the node ("[Power up the nodes](#)" on page 31).

## Remove the bayonet board bracket

1. Power down the node (on page 31).
2. Disconnect all peripheral cables from the node.
3. Remove the node from the chassis (on page 32).
4. Place the node on a flat, level surface.
5. If installed in a 2U node, remove the FlexibleLOM 2U node riser cage assembly ("[FlexibleLOM 2U node riser cage assembly](#)" on page 52).
6. If installed in a 2U node, remove the three-slot PCI riser cage assembly ("[Three-slot PCI riser cage assemblies](#)" on page 53).
7. If a graphic card/ coprocessor power cable is installed, disconnect it from the bayonet board.
8. If a B140i SATA cable is installed, disconnect it from the connectors on the system board.
9. Remove the bayonet board assembly from the node ("[Remove the bayonet board assembly](#)" on page 43).
10. Remove the bayonet board bracket from the bayonet board.
  - o 1U bayonet board bracket

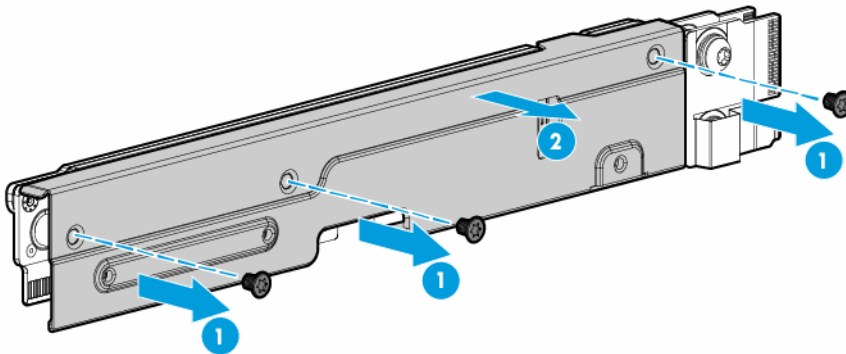

- 2U bayonet board bracket

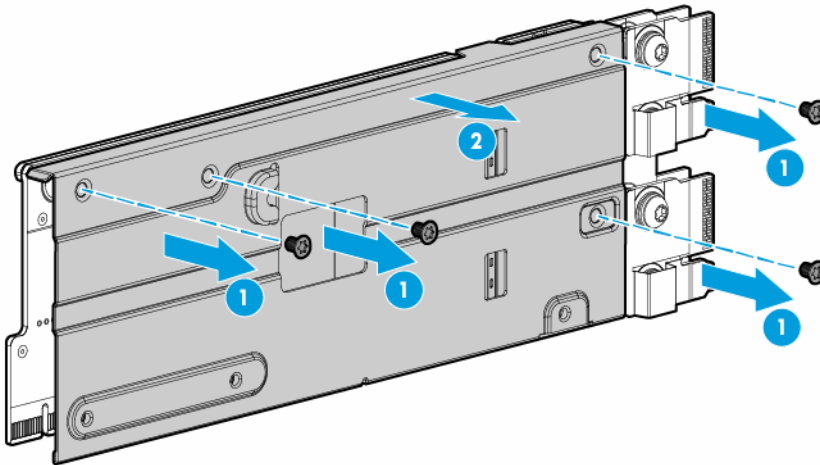

## Install the bayonet board bracket

**NOTE:** If a storage cable is connected to the 2U bayonet board, route the cable under the padding before installing the 2U bayonet board bracket.

1. Install the bayonet board bracket onto the bayonet board.
  - 1U bayonet board bracket

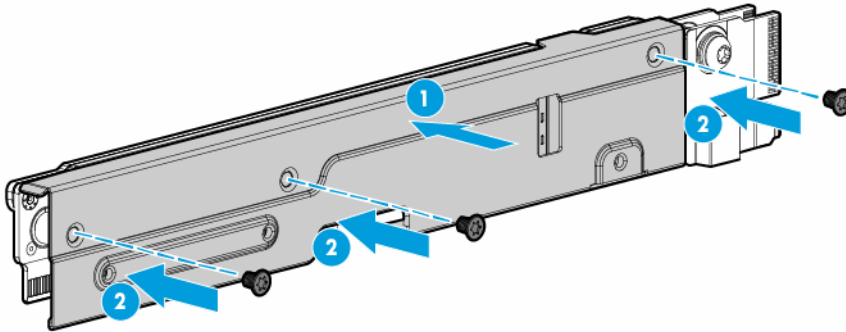

- 2U bayonet board bracket

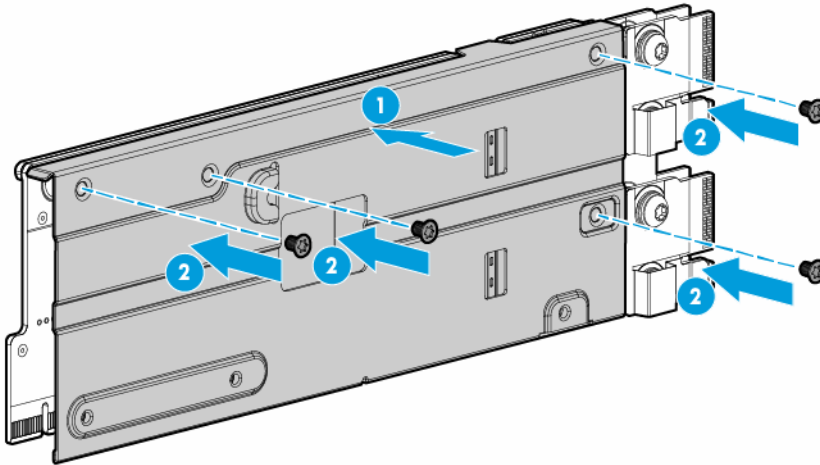

2. Install the bayonet board assembly into the node ("[Install the bayonet board assembly](#)" on page 44).
3. If any SATA or Mini-SAS cables are installed, secure the cables under the thin plastic covers along the side of the node tray.
4. If removed, connect the B140i SATA cable to the connectors on the system board ("[B140i 1U node SATA cable](#)" on page 78, "[B140i 2U node SATA cable](#)" on page 79).
5. If a graphic card/ coprocessor power cable was removed, connect it to the bayonet board..
6. If removed, install the FlexibleLOM 2U node riser cage assembly ("[FlexibleLOM 2U node riser cage assembly option](#)" on page 92) or the three-slot PCI riser cage assembly ("[Three-slot PCI riser cage assembly options](#)" on page 93).
7. Install the node into the chassis ("[Installing a node into the chassis](#)" on page 60).
8. Connect all peripheral cables to the nodes.
9. Power up the node ("[Power up the nodes](#)" on page 31).

## Remove the PCI riser cage assembly



**WARNING:** To reduce the risk of personal injury from hot surfaces, allow the drives and the internal system components to cool before touching them.



**CAUTION:** To prevent damage to the server or expansion boards, power down the server, and disconnect all power cords before removing or installing the PCI riser cage.

## Single-slot left PCI riser cage assembly

To remove the component:

1. Power down the node (on page 31).
2. Disconnect all peripheral cables from the node.
3. Remove the node from the chassis (on page 32).



4. Place the node on a flat, level surface.
5. In a 2U node, remove the three-slot riser cage assembly ("Three-slot PCI riser cage assemblies" on page 53).
6. Remove the single-slot left PCI riser cage assembly:
  - o 1U node

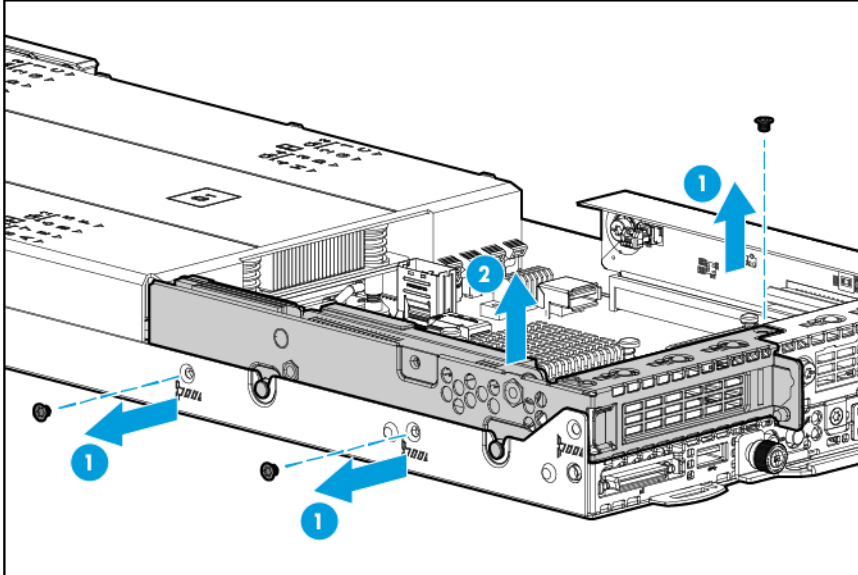

- o 2U node

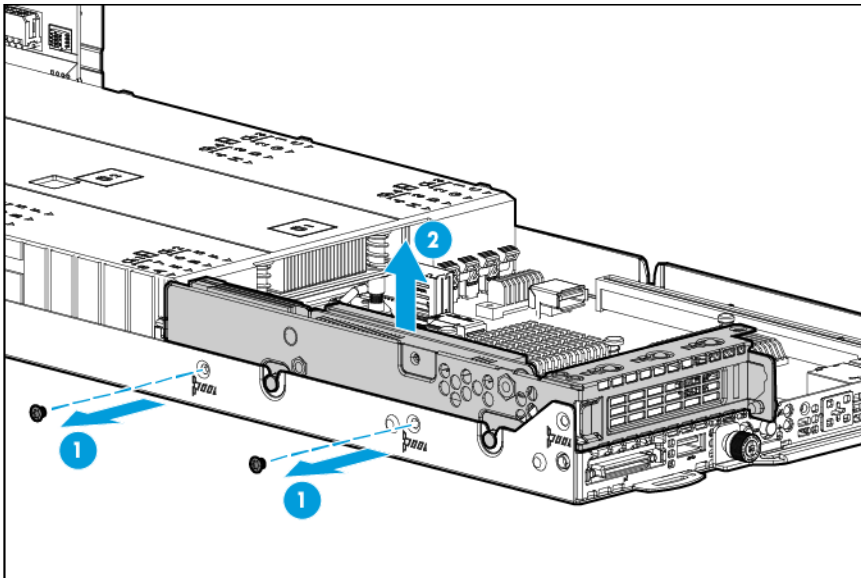

**CAUTION:** To prevent improper cooling and thermal damage, do not operate the node unless all PCI riser cages or rear I/O blanks are installed, and do not operate the node unless all PCI slots have either an expansion slot cover or an expansion board installed.

## Single-slot 1U node right PCI riser cage assembly

To remove the component:

1. Power down the node (on page 31).
2. Disconnect all peripheral cables from the node.
3. Remove the node from the chassis (on page 32).
4. Do one of the following:
  - a. Remove the 1U left rear I/O blank (on page 38).
  - b. Remove the single-slot left PCI riser cage assembly (on page 48).
5. Remove the single-slot 1U node right PCI riser cage assembly.

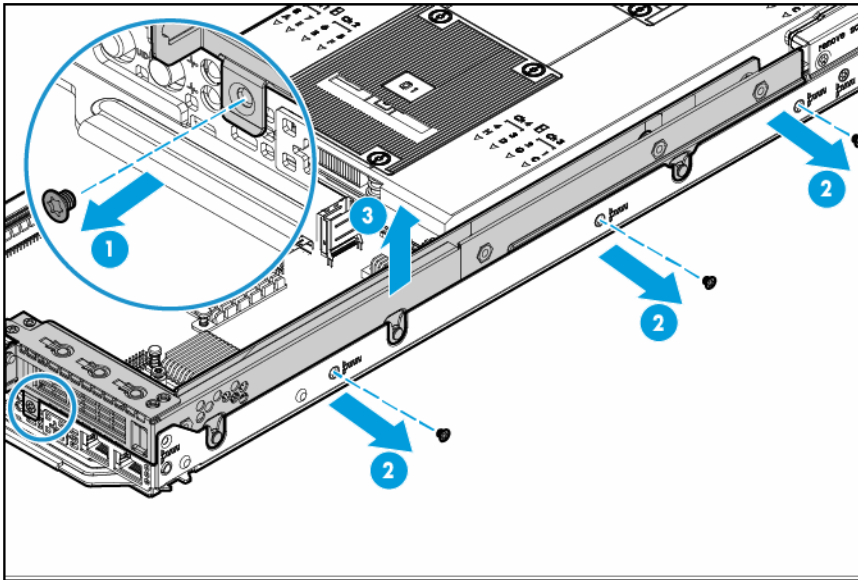

**CAUTION:** To prevent improper cooling and thermal damage, do not operate the node unless all PCI riser cages or rear I/O blanks are installed, and do not operate the node unless all PCI slots have either an expansion slot cover or an expansion board installed.

## FlexibleLOM 1U node riser cage assembly

To remove the component:

1. Power down the node (on page 31).
2. Disconnect all peripheral cables from the node.
3. Remove the node from the chassis (on page 32).
4. Do one of the following:
  - a. Remove the 1U left rear I/O blank (on page 38).
  - b. Remove the single-slot left PCI riser cage assembly (on page 48).

5. Remove the FlexibleLOM 1U node riser cage assembly.

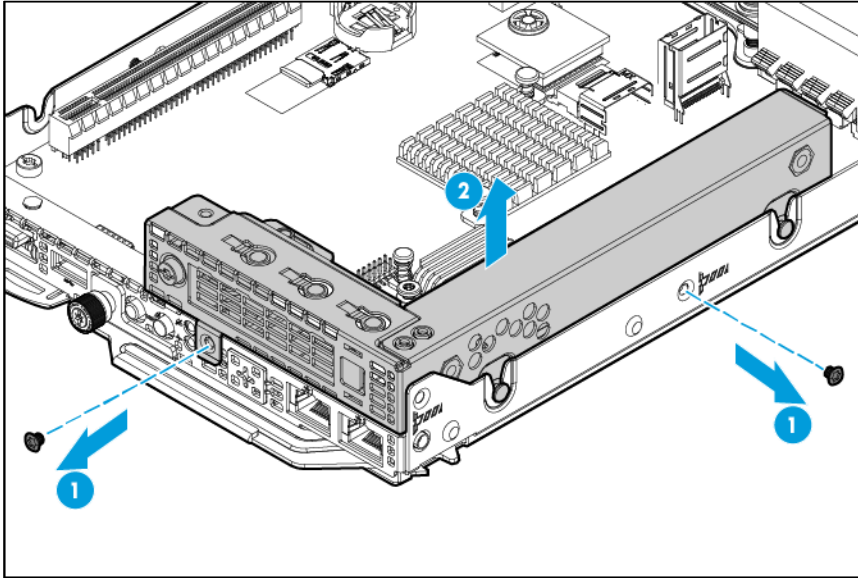

**CAUTION:** To prevent improper cooling and thermal damage, do not operate the node unless all PCI riser cages or rear I/O blanks are installed, and do not operate the node unless all PCI slots have either an expansion slot cover or an expansion board installed.

## Single-slot 2U node PCI riser cage assembly

To remove the component:

1. Power down the node (on page 31).
2. Disconnect all peripheral cables from the node.
3. Remove the node from the chassis (on page 32).
4. Place the node on a flat, level surface.
5. Remove the FlexibleLOM 2U node riser cage assembly (on page 52).

6. Remove the single-slot 2U node PCI riser cage assembly.

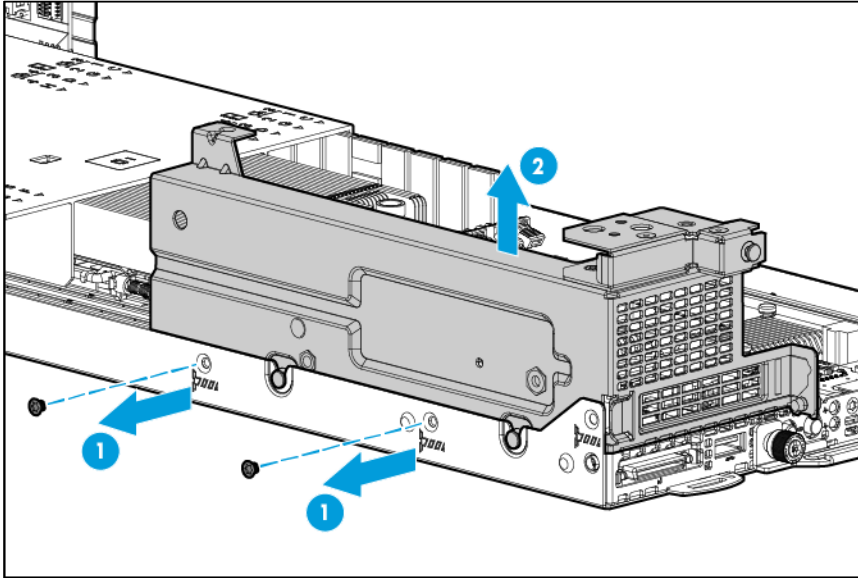

**CAUTION:** To prevent improper cooling and thermal damage, do not operate the node unless all PCI riser cages or rear I/O blanks are installed, and do not operate the node unless all PCI slots have either an expansion slot cover or an expansion board installed.

## FlexibleLOM 2U node riser cage assembly

To remove the component:

1. Power down the node (on page 31).
2. Disconnect all peripheral cables from the node.
3. Remove the node from the chassis (on page 32).
4. Place the node on a flat, level surface.
5. Remove the FlexibleLOM 2U node riser cage assembly.

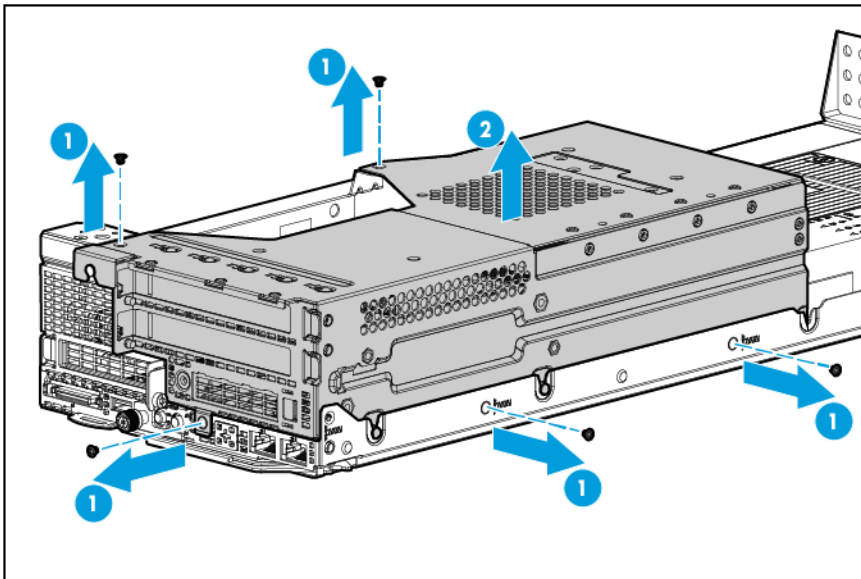

## Three-slot PCI riser cage assemblies

**NOTE:** The three-slot PCI riser cage assembly and the three-slot GPU-direct PCI riser cage assembly, share the same riser cage but have a different riser board. For more information on the riser board slot specifications, see "PCIe riser board slot definitions (on page 27)."

To remove the component:

1. Power down the node (on page 31).
2. Disconnect all peripheral cables from the node.
3. Remove the node from the chassis (on page 32).
4. Place the node on a flat, level surface.
5. Remove the three-slot riser cage assembly.

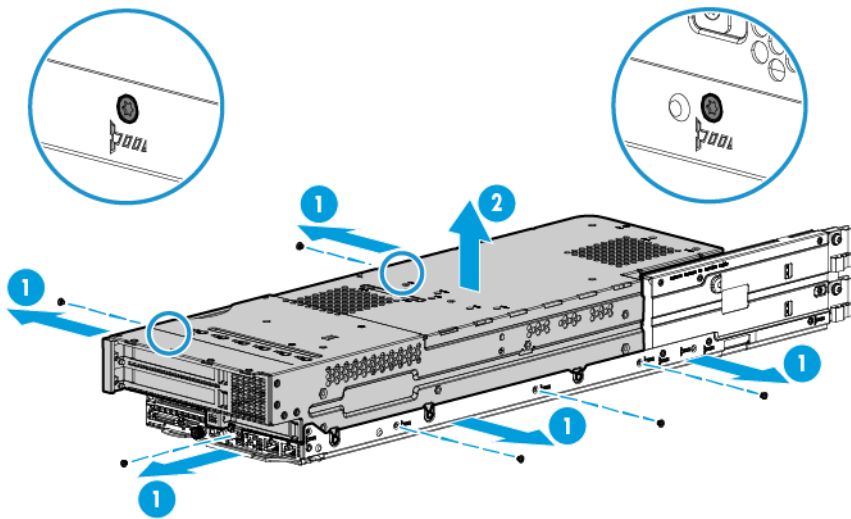

**CAUTION:** To prevent improper cooling and thermal damage, do not operate the node unless all PCI riser cages or rear I/O blanks are installed, and do not operate the node unless all PCI slots have either an expansion slot cover or an expansion board installed.

---

# Setup

## Installation overview

To set up and install the HP Apollo 2000 System:

1. Set up and install the rack. For more information, see the documentation that ships with the rack.
2. Prepare the chassis ("[Preparing the chassis](#)" on page 58).
3. Install any hardware options into the chassis and nodes ("[Hardware options installation](#)" on page 64).

---

**NOTE:** Install the chassis into the rack before installing drives, power supplies, the RCM module, or nodes.

---

4. Install the chassis into the rack ("[Installing the chassis into the rack](#)" on page 59).
5. Install all nodes, drives and power supplies ("[Chassis component installation](#)" on page 60).
6. Power up the chassis ("[Powering up the chassis](#)" on page 62).
7. Install an operating system ("[Installing the operating system](#)" on page 62).
8. Install the system software ("[Installing the system software](#)" on page 63).
9. Register the server ("[Registering the server](#)" on page 63).

## Optional services

Delivered by experienced, certified engineers, HP Care Pack services help you keep your servers up and running with support packages tailored specifically for HP ProLiant systems. HP Care Packs let you integrate both hardware and software support into a single package. A number of service level options are available to meet your needs.

HP Care Pack Services offer upgraded service levels to expand your standard product warranty with easy-to-buy, easy-to-use support packages that help you make the most of your server investments. Some of the Care Pack services are:

- Hardware support
  - 6-Hour Call-to-Repair
  - 4-Hour 24x7 Same Day
  - 4-Hour Same Business Day
- Software support
  - Microsoft®
  - Linux
  - HP ProLiant Essentials (HP SIM and RDP)
  - VMware
- Integrated hardware and software support
  - Critical Service

- Proactive 24
- Support Plus
- Support Plus 24
- Startup and implementation services for both hardware and software

For more information on HP Care Pack Services, see the HP website (<http://www.hp.com/services/carepack>).

## Optimum environment

When installing the server, select a location that meets the environmental standards described in this section.

### Space and airflow requirements

To allow for servicing and adequate airflow, observe the following space and airflow requirements when deciding where to install a rack:

- Leave a minimum clearance of 85.09 cm (33.5 in) in front of the rack.
- Leave a minimum clearance of 76.2 cm (30 in) behind the rack.
- Leave a minimum clearance of 121.9 cm (48 in) from the back of the rack to the back of another rack or row of racks.

HP nodes draw in cool air through the front door and expel warm air through the rear door. Therefore, the front and rear rack doors must be adequately ventilated to allow ambient room air to enter the cabinet, and the rear door must be adequately ventilated to allow the warm air to escape from the cabinet.

---

 **CAUTION:** To prevent improper cooling and damage to the equipment, do not block the ventilation openings.

---

When vertical space in the rack is not filled by a server or rack component, the gaps between the components cause changes in airflow through the rack and across the servers. Cover all gaps with blanking panels to maintain proper airflow.

---

 **CAUTION:** Always use blanking panels to fill empty vertical spaces in the rack. This arrangement ensures proper airflow. Using a rack without blanking panels results in improper cooling that can lead to thermal damage.

---

The 9000 and 10000 Series Racks provide proper server cooling from flow-through perforations in the front and rear doors that provide 64 percent open area for ventilation.

---

 **CAUTION:** When using a Compaq branded 7000 series rack, install the high airflow rack door insert (PN 327281-B21 for 42U rack, PN 157847-B21 for 22U rack) to provide proper front-to-back airflow and cooling.

---

---

 **CAUTION:** If a third-party rack is used, observe the following additional requirements to ensure adequate airflow and to prevent damage to the equipment:

- Front and rear doors—If the 42U rack includes closing front and rear doors, you must allow 5,350 sq cm (830 sq in) of holes evenly distributed from top to bottom to permit adequate airflow (equivalent to the required 64 percent open area for ventilation).
- Side—The clearance between the installed rack component and the side panels of the rack must be a minimum of 7 cm (2.75 in).

---

## Temperature requirements

To ensure continued safe and reliable equipment operation, install or position the system in a well-ventilated, climate-controlled environment.

The maximum recommended ambient operating temperature (TMRA) for most server products is 35°C (95°F). The temperature in the room where the rack is located must not exceed 35°C (95°F).

- 
-  **CAUTION:** To reduce the risk of damage to the equipment when installing third-party options:
- Do not permit optional equipment to impede airflow around the server or to increase the internal rack temperature beyond the maximum allowable limits.
  - Do not exceed the manufacturer's TMRA.
- 

## Power requirements

Installation of this equipment must comply with local and regional electrical regulations governing the installation of information technology equipment by licensed electricians. This equipment is designed to operate in installations covered by NFPA 70, 1999 Edition (National Electric Code) and NFPA-75, 1992 (code for Protection of Electronic Computer/Data Processing Equipment). For electrical power ratings on options, refer to the product rating label or the user documentation supplied with that option.

- 
-  **WARNING:** To reduce the risk of personal injury, fire, or damage to the equipment, do not overload the AC supply branch circuit that provides power to the rack. Consult the electrical authority having jurisdiction over wiring and installation requirements of your facility.
- 

-  **CAUTION:** Protect the server from power fluctuations and temporary interruptions with a regulating uninterruptible power supply. This device protects the hardware from damage caused by power surges and voltage spikes and keeps the system in operation during a power failure.
- 

When installing more than one server, you might need to use additional power distribution devices to safely provide power to all devices. Observe the following guidelines:

- Balance the server power load between available AC supply branch circuits.
- Do not allow the overall system AC current load to exceed 80% of the branch circuit AC current rating.
- Do not use common power outlet strips for this equipment.
- Provide a separate electrical circuit for the server.

For more information on the hot-plug power supply and calculators to determine server power consumption in various system configurations, see the HP Power Advisor website (<http://www.hp.com/go/hppoweradvisor>).

## Electrical grounding requirements





The server must be grounded properly for proper operation and safety. In the United States, you must install the equipment in accordance with NFPA 70, 1999 Edition (National Electric Code), Article 250, as well as any local and regional building codes. In Canada, you must install the equipment in accordance with Canadian Standards Association, CSA C22.1, Canadian Electrical Code. In all other countries, you must install the equipment in accordance with any regional or national electrical wiring codes, such as the International Electrotechnical Commission (IEC) Code 364, parts 1 through 7. Furthermore, you must be sure



that all power distribution devices used in the installation, such as branch wiring and receptacles, are listed or certified grounding-type devices.

Because of the high ground-leakage currents associated with multiple servers connected to the same power source, HP recommends the use of a PDU that is either permanently wired to the building's branch circuit or includes a nondetachable cord that is wired to an industrial-style plug. NEMA locking-style plugs or those complying with IEC 60309 are considered suitable for this purpose. Using common power outlet strips for the server is not recommended.

## Server warnings and cautions

- 
-  **WARNING:** This server is very heavy. To reduce the risk of personal injury or damage to the equipment:
- Observe local occupational health and safety requirements and guidelines for manual material handling.
  - Get help to lift and stabilize the product during installation or removal, especially when the product is not fastened to the rails. HP recommends that a minimum of two people are required for all rack server installations. A third person may be required to help align the server if the server is installed higher than chest level.
  - Use caution when installing the server or removing the server from the rack; it is unstable when not fastened to the rails.
- 
-  **WARNING:** To reduce the risk of personal injury from hot surfaces, allow the drives and the internal system components to cool before touching them.
- 
-  **WARNING:** To reduce the risk of personal injury, electric shock, or damage to the equipment, remove the power cord to remove power from the server. The front panel Power On/Standby button does not completely shut off system power. Portions of the power supply and some internal circuitry remain active until AC power is removed.
- 
-  **CAUTION:** Protect the server from power fluctuations and temporary interruptions with a regulating uninterruptible power supply. This device protects the hardware from damage caused by power surges and voltage spikes and keeps the system in operation during a power failure.
- 
-  **CAUTION:** Do not operate the server for long periods with the access panel open or removed. Operating the server in this manner results in improper airflow and improper cooling that can lead to thermal damage.
- 

## Rack warnings

- 
-  **WARNING:** To reduce the risk of personal injury or damage to the equipment, be sure that:
- The leveling jacks are extended to the floor.
  - The full weight of the rack rests on the leveling jacks.
  - The stabilizing feet are attached to the rack if it is a single-rack installation.
  - The racks are coupled together in multiple-rack installations.
  - Only one component is extended at a time. A rack may become unstable if more than one component is extended for any reason.
-

- 
- ⚠ WARNING:** To reduce the risk of personal injury or equipment damage when unloading a rack:
- At least two people are needed to safely unload the rack from the pallet. An empty 42U rack can weigh as much as 115 kg (253 lb), can stand more than 2.1 m (7 ft) tall, and might become unstable when being moved on its casters.
  - Never stand in front of the rack when it is rolling down the ramp from the pallet. Always handle the rack from both sides.
- 
- ⚠ WARNING:** To reduce the risk of personal injury or damage to the equipment, adequately stabilize the rack before extending a component outside the rack. Extend only one component at a time. A rack may become unstable if more than one component is extended.
- 
- ⚠ WARNING:** When installing a server in a telco rack, be sure that the rack frame is adequately secured at the top and bottom to the building structure.
- 

## Identifying the contents of the server shipping carton

Unpack the server shipping carton and locate the materials and documentation necessary for installing the server. All the rack mounting hardware necessary for installing the server into the rack is included with the rack or the server.

The contents of the server shipping carton include:

- Server
- Power cord
- Rack rail hook-and-loop strap
- Rack mounting hardware kit
- Printed setup documentation

In addition to the supplied items, you might need:

- T-25 Torx screwdriver (to loosen the shipping screws located inside the node quick-release latch rack ears)
- T-10/T-15 Torx screwdriver
- Flathead screwdriver (to remove the knockout on the dedicated iLO connector opening)
- Hardware options

## Preparing the chassis





Before installing the chassis into the rack, you must remove the nodes, the drives, and the power supplies. Because a fully populated chassis is heavy, removing these components facilitates moving and installing the chassis.

1. Remove the power supply (on page 33).
2. Remove the nodes ("[Remove the node from the chassis](#)" on page 32).
3. Remove all drives ("[Removing the drive](#)" on page 35).

# Installing hardware options



Install any hardware options before initializing the server. For options installation information, see the option documentation. For server-specific information, see "Hardware options installation (on page 64)."

## Installing the chassis into the rack

- 
-  **WARNING:** Always use at least two people to lift the chassis into the rack. If the chassis is being loaded into the rack above chest level, a third person must assist with aligning the chassis with the rails while the other two people support the weight of the chassis.
- 
-  **WARNING:** The chassis is very heavy. To reduce the risk of personal injury or damage to the equipment:
- Observe local occupational health and safety requirements and guidelines for manual material handling.
  - Remove all installed components from the chassis before installing or moving the chassis.
  - Use caution and get help to lift and stabilize the chassis during installation or removal, especially when the chassis is not fastened to the rack.
- 
-  **WARNING:** To avoid risk of personal injury or damage to the equipment, do not stack anything on top of rail-mounted equipment or use it as a work surface when extended from the rack.
- 
-  **CAUTION:** Always plan the rack installation so that the heaviest item is on the bottom of the rack. Install the heaviest item first, and continue to populate the rack from the bottom to the top.
- 

The chassis requires installation in a rack. To install the rack rails, see the *Quick Deploy Rail System Installation Instructions* that ship with the rack hardware kit.

You can install up to twenty-one chassis in a 42U, 1200 mm deep rack. If you are installing more than one chassis, install the first chassis in the bottom of the rack, and then install additional chassis by moving up the rack with each subsequent chassis. Plan the rack installation carefully, because changing the location of installed components might be difficult.

- 
-  **WARNING:** To reduce the risk of personal injury or damage to the equipment, be sure that:
- The rack is bolted to the floor using the concrete anchor kit.
  - The leveling feet extend to the floor.
  - The full weight of the rack rests on the leveling feet.
  - The racks are coupled together in multiple rack installations.
  - Only one component is extended at a time. If more than one component is extended, a rack might become unstable.
- 
-  **WARNING:** To reduce the risk of personal injury or equipment damage, be sure that the rack is adequately stabilized before installing the chassis.
- 
-  **CAUTION:** Be sure to keep the product parallel to the floor when installing the chassis. Tilting the product up or down could result in damage to the slides.
-

Install the chassis into the rack and tighten the thumbscrews.

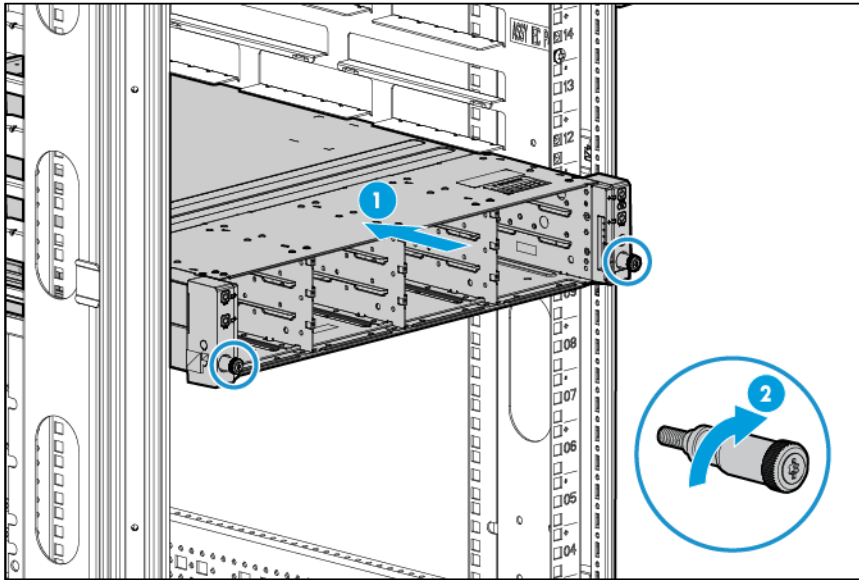

## Chassis component installation

### Installing a node into the chassis

- 1U node

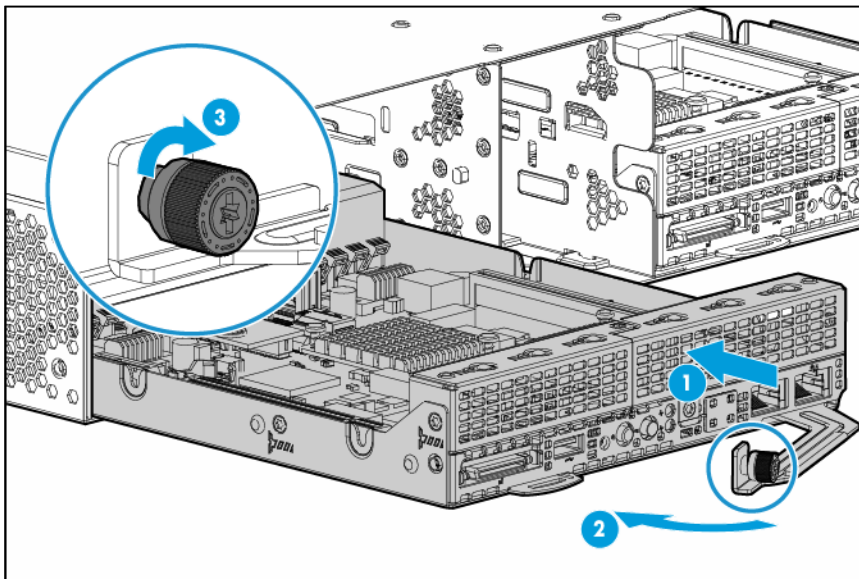

- 2U node

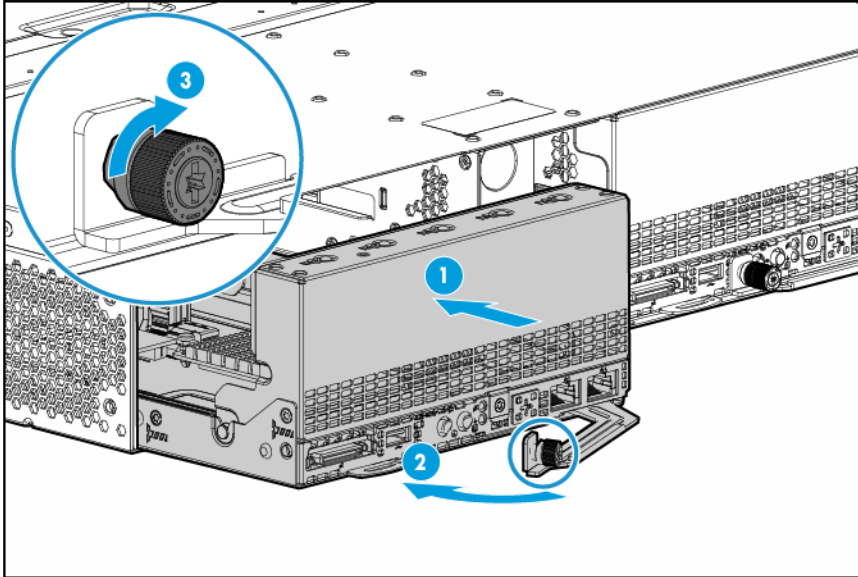

## Installing a drive

1. Remove the drive blank ("[Removing a drive blank](#)" on page 65).
2. Install the drives ("[Drive options](#)" on page 64).

## Installing the power supplies

**CAUTION:** Do not mix power supplies with different efficiency and wattage in the chassis. Install only one type of power supply in a single chassis.

1. If installing a second power supply, remove the power supply blank.
2. Slide the power supplies into the power supply bays until they click into place.

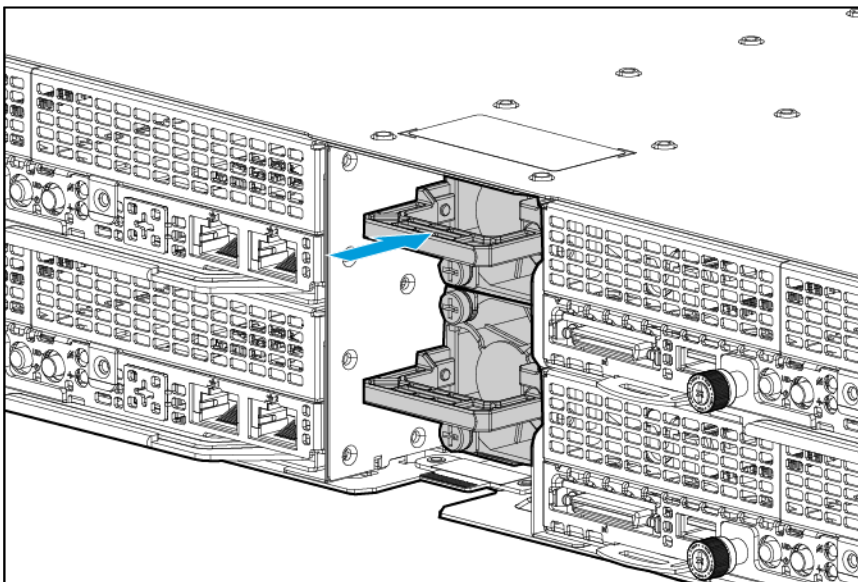

3. If needed, install an RCM module ("[Rack control management \(RCM\) module](#)" on page 67).

4. Connect all power cords and secure them with the strain release straps.

## Powering up the chassis

Connect the AC or DC power cables, depending on the power configuration.

When the circuit breakers are powered, the chassis and HP Advanced Power Manager have power. By default, each installed component also powers up. Examine the HP Advanced Power Manager for any errors which may prevent installed components from powering up.

## HP Advanced Power Manager (optional)

To install, configure, and access HP APM, see the *HP Advanced Power Manager User Guide* on the HP website (<http://www.hp.com/go/docs>).

## Powering on and selecting boot options in UEFI Boot Mode

On servers operating in UEFI Boot Mode, the boot controller and boot order are set automatically.

1. Press the Power On/Standby button.
2. During the initial boot:
  - o To modify the server configuration ROM default settings, press the **F9** key in the HP ProLiant POST screen to enter the UEFI System Utilities screen. By default, the System Utilities menus are in the English language.
  - o If you do not need to modify the server configuration and are ready to install the system software, press the **F10** key to access Intelligent Provisioning.

For more information on automatic configuration, see the UEFI documentation on the HP website (<http://www.hp.com/go/ProLiantUEFI/docs>).

## Installing the operating system

To operate properly, the node must have a supported operating system installed. For the latest information on operating system support, see the HP website (<http://www.hp.com/go/supportos>).



---

**IMPORTANT:** HP ProLiant XL servers do not support operating system installation with Intelligent Provisioning, but do support the maintenance features. For more information, see the Performing Maintenance section of the *HP Intelligent Provisioning User Guide* and online help.

---

To install an operating system on the node, use one of the following methods:

- Manual installation—Insert the operating system CD into the USB-attached DVD-ROM drive (user provided) and reboot the node. You must download the HP Service Pack for ProLiant from the SPP download site (<http://www.hp.com/go/spp/download>) and create SPP media so that you can install the drivers.
- Remote deployment installation—Use Insight Control server provisioning for an automated solution to remotely deploy an operating system.

For additional system software and firmware updates, download the HP Service Pack for ProLiant from the HP website (<http://www.hp.com/go/spp/download>). Software and firmware should be updated before using the node for the first time, unless any installed software or components require an older version.

For more information on using these installation methods, see the HP website (<http://www.hp.com/go/ilo>).

## Installing the system software

To access and configure Intelligent Provisioning on a single node:

1. Access Intelligent Provisioning by rebooting the server and pressing **F10**.
2. The first time you log into Intelligent Provisioning, follow the steps to set preferences and activate Intelligent Provisioning.
3. From the Home screen, click **Perform Maintenance**, and then click **Firmware Update**.
4. Ensure the latest drivers are available for installation. Select **Intelligent Provisioning Software** from the list of firmware, and click **Update**. If the check box is not selected, the latest drivers are already installed.

## Registering the server

To experience quicker service and more efficient support, register the product at the HP Product Registration website (<http://register.hp.com>).

# Hardware options installation

## Introduction

If more than one option is being installed, read the installation instructions for all the hardware options and identify similar steps to streamline the installation process.

**WARNING:** To reduce the risk of personal injury from hot surfaces, allow the drives and the internal system components to cool before touching them.

**CAUTION:** To prevent damage to electrical components, properly ground the server before beginning any installation procedure. Improper grounding can cause electrostatic discharge.

## Security bezel option

The security bezel helps prevent unauthorized physical access to the front panel components. Install the security bezel and then lock it with the key provided with the kit.

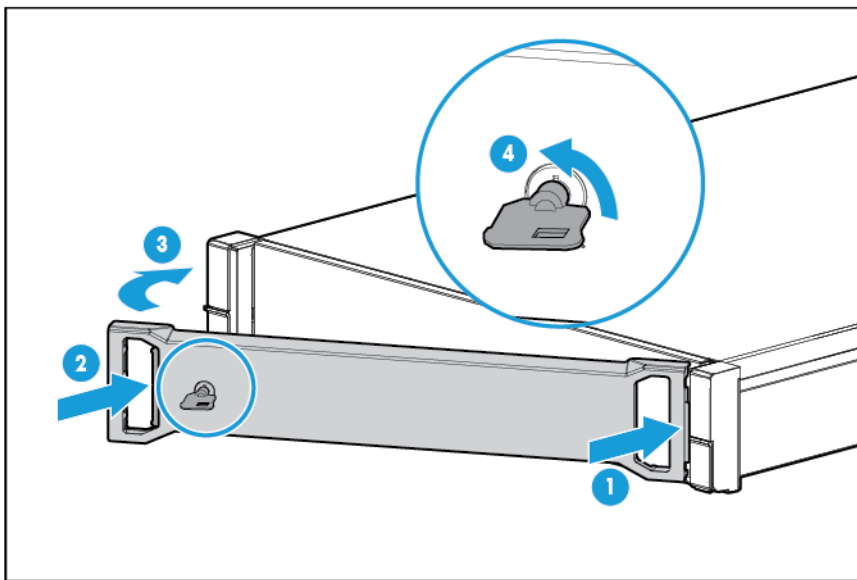

## Drive options

The embedded HP Dynamic Smart Array B140i Controller only supports SATA devices. For SAS drive installation, install an HP Host Bus Adapter or an HP Smart Array Controller board option.

For more information about product features, specifications, options, configurations, and compatibility, see the product QuickSpecs on the HP website (<http://www.hp.com/go/qs>).



## Removing a drive blank

1. If installed, remove the security bezel (on page 35).
2. Remove the drive blank.

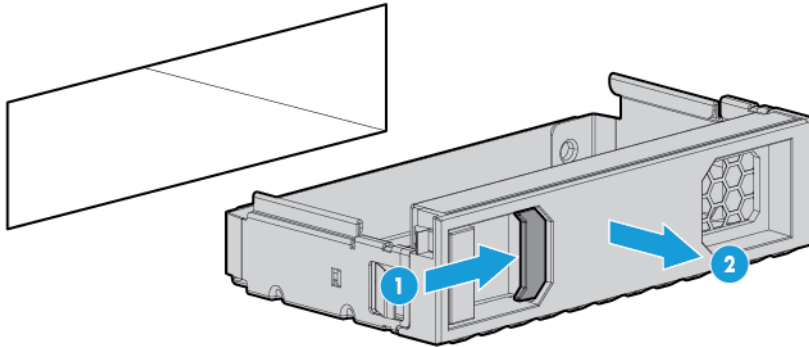

## Installing a hot-plug drive



**WARNING:** To reduce the risk of injury from electric shock, do not install more than one drive carrier at a time.

The chassis can support up to 12 drives in an LFF configuration and up to 24 drives in an SFF configuration.

To install the component:

1. If installed, remove the security bezel (on page 35).
2. Remove the drive blank ("Removing a drive blank" on page 65).
3. Prepare the drive.
  - o SFF HP SmartDrive

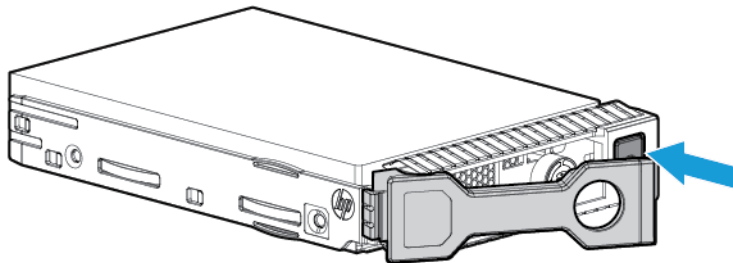

- Low-profile LFF hot-plug drive

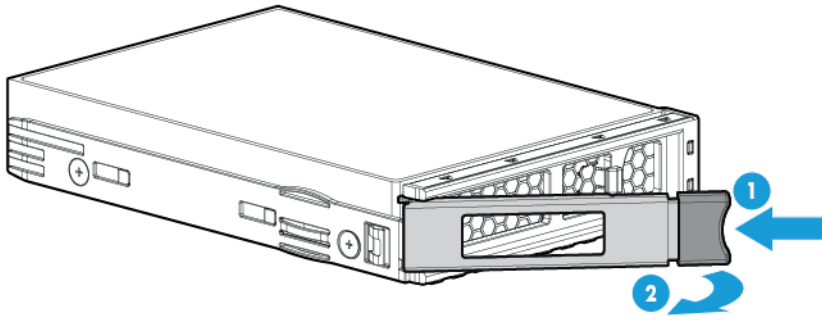

4. Install the drive:
  - SFF HP SmartDrive

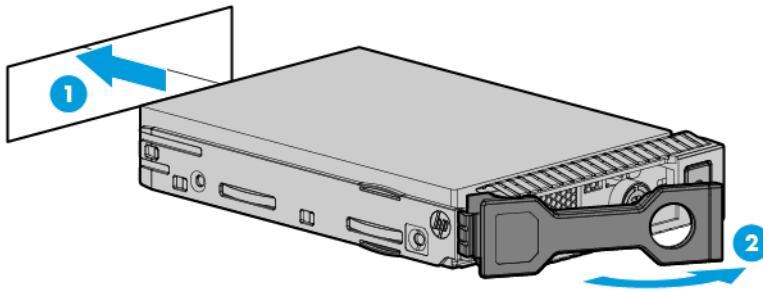

- Low-profile LFF hot-plug drive

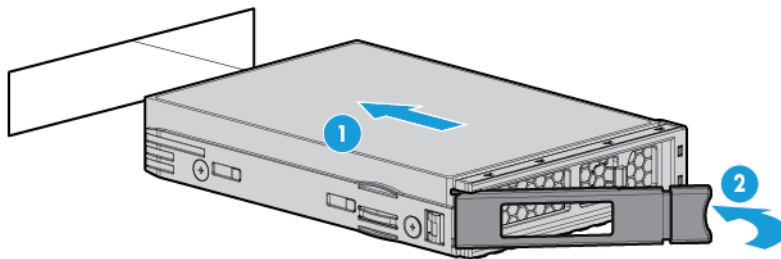

5. Determine the status of the drive from the drive LED definitions ("HP SmartDrive LED definitions" on page 22, "Hot-plug drive LED definitions" on page 22).
6. If removed, install the security bezel ("Security bezel option" on page 64).

To configure arrays, see the *HP Smart Storage Administrator User Guide* on the HP website (<http://www.hp.com/go/smartstorage/docs>).

# Node blank

For more information about product features, specifications, options, configurations, and compatibility, see the product QuickSpecs on the HP website (<http://www.hp.com/go/qs>).

- Install the node blank into the left side of the server chassis.

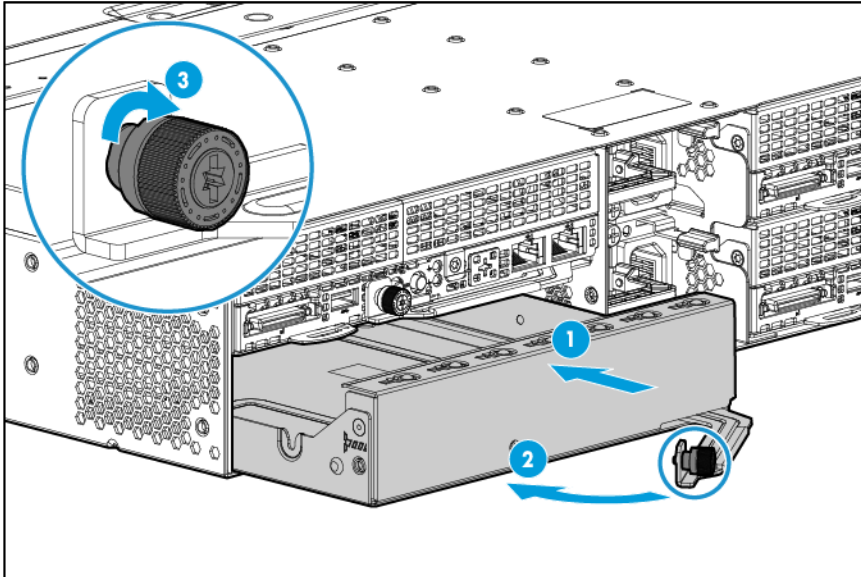

- Install the node blank into the right side of the server chassis.

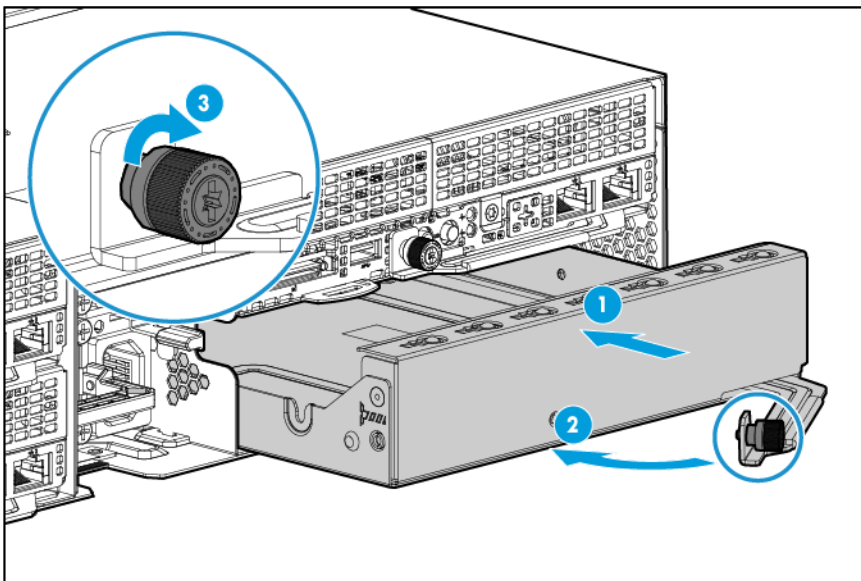

# Rack control management (RCM) module

For more information about product features, specifications, options, configurations, and compatibility, see the product QuickSpecs on the HP website (<http://www.hp.com/go/qs>).

To install the component:

1. Power down the nodes ("Power down the node" on page 31).

2. Disconnect each power cord from the power source.
3. Remove the power supply relief strap from the handle on the bottom power supply.
4. Install the rack control management module onto the bottom power supply.

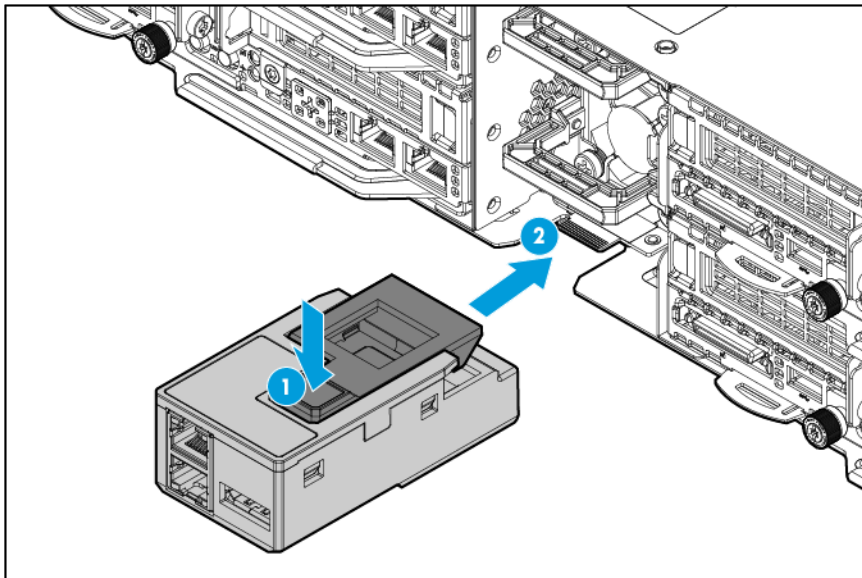

5. Reconnect all power:
  - a. Connect each power cord to the power source.
  - b. Connect the power cord to the chassis.
6. Power up the nodes (on page 31).



**IMPORTANT:** Use either the HP APM port or an iLO port to connect to a network. Having both ports connected at the same time results in a loopback condition.



**IMPORTANT:** Do not connect both iLO ports to the network at the same time. Only one iLO port can be connected to the network, while the other iLO port can be used only as a connection to a second enclosure. Having both ports connected at the same time results in a loopback condition.

7. If using the RCM module iLO ports to connect the chassis to a network, connect all cables to the RCM module and the network. Multiple chassis can be connected to the same network.

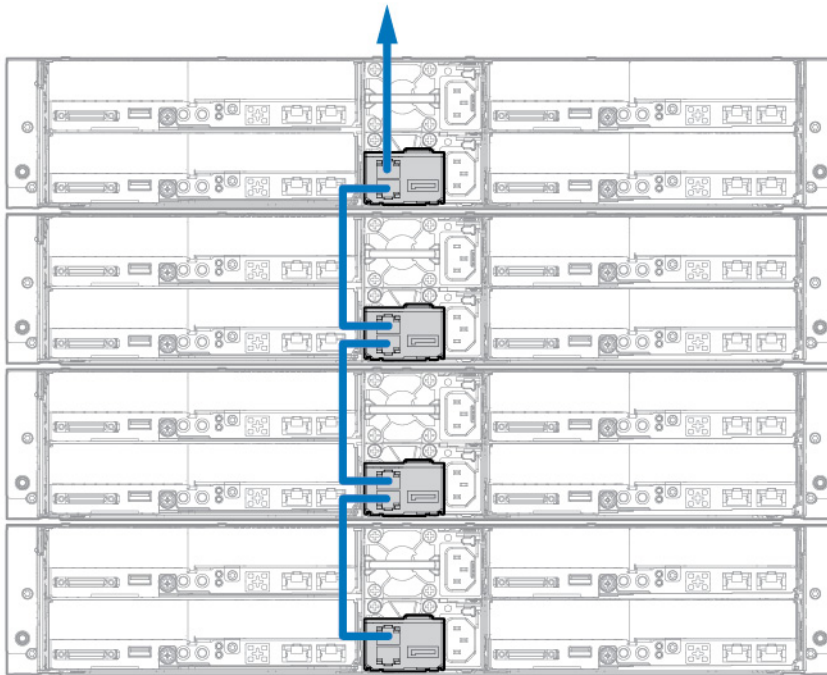

---

**NOTE:** Arrow indicates connection to the network.

---

8. If installing HP APM, see the *HP Advanced Power Manager User Guide* on the HP website (<http://www.hp.com/go/docs>).

## RCM 2.0 to 1.0 adapter cable

For more information about product features, specifications, options, configurations, and compatibility, see the product QuickSpecs on the HP website (<http://www.hp.com/go/qs>).

To install the component:

1. Power down the system. ("Power down the system" on page 31)
2. Disconnect each power cord from the power source.
3. Install the rack control management module ("Rack control management (RCM) module" on page 67).

4. Connect the RCM 2.0 to 1.0 adapter cable to the RCM module.

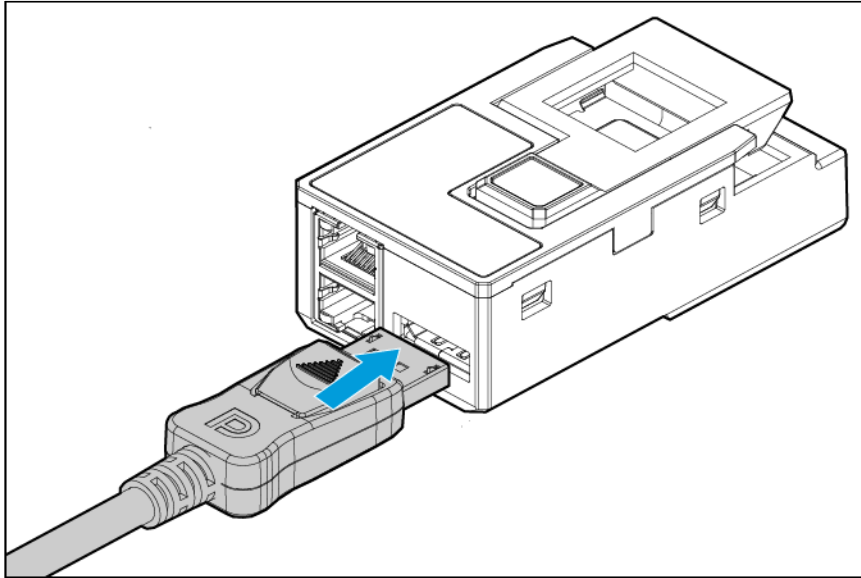

5. Reconnect all power:
  - a. Connect each power cord to the power source.
  - b. Connect the power cord to the chassis.
6. Power up the nodes (on page 31).
7. To install, configure, and access HP APM, see the *HP Advanced Power Manager User Guide* on the HP website (<http://www.hp.com/go/docs>).

## Redundant fan option

### Fan population guidelines

To provide sufficient airflow to the system if a fan fails, the server supports redundant fans.

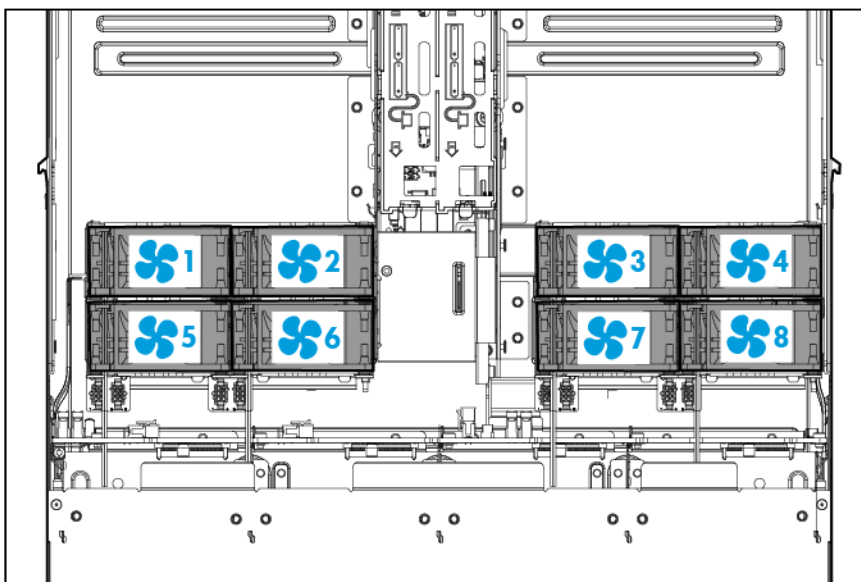

Configuration	Fan bay 1	Fan bay 2	Fan bay 3	Fan bay 4	Fan bay 5	Fan bay 6	Fan bay 7	Fan bay 8
Non-redundant	Fan	Fan	Fan	Fan	Empty	Empty	Empty	Empty
Redundant	Fan	Fan	Fan	Fan	Fan	Fan	Fan	Fan

- In a redundant fan mode:
  - If one fan fails, the system continues to operate without redundancy. This condition is indicated by a flashing amber Health LED.
  - If two fans fail, the system shuts down.
- The minimum fan requirement for this server to power on is four fans (fans 1, 2, 3, and 4).

## Installing the fan option

For more information about product features, specifications, options, configurations, and compatibility, see the product QuickSpecs on the HP website (<http://www.hp.com/go/qs>).

To install the component:

1. Power down the system (on page 31).
2. Disconnect all peripheral cables from the nodes and chassis.
3. Remove the node from the chassis (on page 32).
4. If installed, remove the security bezel (on page 35).
5. Remove all drives ("Removing the drive" on page 35).
6. If installed, remove the RCM module (on page 33).
7. Remove all power supplies ("Remove the power supply" on page 33).
8. Remove the chassis from the rack (on page 34).
9. Remove the access panel ("Remove the chassis access panel" on page 36).
10. Install the redundant fans in the left and right fan cages.

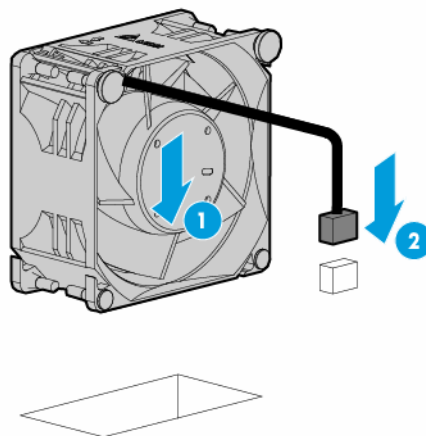

11. Connect the fan cables to the power connectors.



12. Install the access panel ("[Install the chassis access panel](#)" on page 37)
13. Install the chassis into the rack ("[Installing the chassis into the rack](#)" on page 59).
14. If removed, install the security bezel ("[Security bezel option](#)" on page 64).
15. Install all nodes, drives and power supplies ("[Chassis component installation](#)" on page 60).
16. Reconnect all power:
  - a. Connect each power cord to the power source.
  - b. Connect the power cord to the chassis.
17. Connect all peripheral cables to the nodes.
18. Power up the nodes (on page 31).

## Memory options



**IMPORTANT:** This node does not support mixing LRDIMMs or RDIMMs. Attempting to mix any combination of these DIMMs can cause the server to halt during BIOS initialization.

The memory subsystem in this node can support LRDIMMs and RDIMMs:

- RDIMMs offer address parity protection.
- LRDIMMs support higher densities than single- and dual-rank RDIMMs, and higher speeds than quad-rank RDIMMs. This support enables you to install more high capacity DIMMs, resulting in higher system capacities and higher bandwidth.

All types are referred to as DIMMs when the information applies to all types. When specified as LRDIMM or RDIMM, the information applies to that type only. All memory installed in the node must be the same type.

The server supports the following RDIMM and LRDIMM speeds:

- Single- and dual-rank PC4-2133 (DDR4-2133) RDIMMs and LRDIMMs operating at up to 2133 MT/s

### Speed and capacity



DIMM type	DIMM rank	DIMM capacity	Native speed (MT/s)
RDIMM	Single-rank	4 GB	2133
RDIMM	Single-rank	8 GB	2133
RDIMM	Dual-rank	8 GB	2133
RDIMM	Dual-rank	16 GB	2133
LRDIMM	Dual-rank	16 GB	2133
RDIMM	Dual-rank	32 GB	2133
LRDIMM	Quad-rank	32 GB	2133

#### Populated DIMM speed (MT/s)

DIMM type	DIMM rank	1 DIMM per channel	2 DIMMs per channel
RDIMM	Single-rank	2133	2133
RDIMM	Dual-rank	2133	2133
LRDIMM	Dual-rank	2133	2133
LRDIMM	Quad-rank	2133	2133

For more information about product features, specifications, options, configurations, and compatibility, see the product QuickSpecs on the HP website (<http://www.hp.com/go/qs>).

## HP SmartMemory

HP SmartMemory authenticates and unlocks certain features available only on HP Qualified memory and verifies whether installed memory has passed HP qualification and test processes. Qualified memory is performance-tuned for HP ProLiant and BladeSystem servers and provides future enhanced support through HP Active Health and manageability software.

## Memory subsystem architecture

The memory subsystem in this node is divided into channels. Each processor supports four channels, and each channel supports two DIMM slots, as shown in the following table.

Channel	Population order	Slot number
1	A	8
	E	7
2	B	6
	F	5
3	C	1
	G	2
4	D	3
	H	4

For the location of the slot numbers, see "DIMM slot locations (on page 19)."

This multi-channel architecture provides enhanced performance in Advanced ECC mode. This architecture also enables Online Spare Memory mode.

DIMM slots in this server are identified by number and by letter. Letters identify the population order. Slot numbers indicate the DIMM slot ID for spare replacement.

# Single-, dual-, and quad-rank DIMMs

To understand and configure memory protection modes properly, an understanding of single-, dual-, and quad-rank DIMMs is helpful. Some DIMM configuration requirements are based on these classifications.

A single-rank DIMM has one set of memory chips that is accessed while writing to or reading from the memory. A dual-rank DIMM is similar to having two single-rank DIMMs on the same module, with only one rank accessible at a time. A quad-rank DIMM is, effectively, two dual-rank DIMMs on the same module. Only one rank is accessible at a time. The node memory control subsystem selects the proper rank within the DIMM when writing to or reading from the DIMM.

Dual- and quad-rank DIMMs provide the greatest capacity with the existing memory technology. For example, if current DRAM technology supports 8-GB single-rank DIMMs, a dual-rank DIMM would be 16 GB, and a quad-rank DIMM would be 32 GB.

LRDIMMs are labeled as quad-rank DIMMs. There are four ranks of DRAM on the DIMM, but the LRDIMM buffer creates an abstraction that allows the DIMM to appear as a dual-rank DIMM to the system. The LRDIMM buffer isolates the electrical loading of the DRAM from the system to allow for faster operation. This allows higher memory operating speed compared to quad-rank RDIMMs.

## DIMM identification

To determine DIMM characteristics, use the label attached to the DIMM and the following illustration and table.

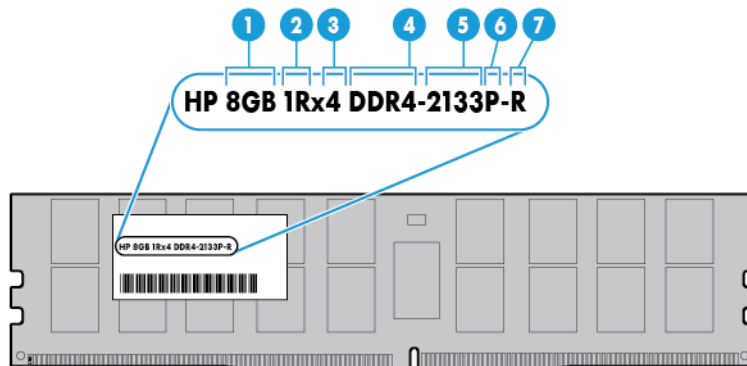

	Description	Definition
1	Capacity	4 GB 8 GB 16 GB 32 GB
2	Rank	1R = Single-rank 2R = Dual-rank 4R = Quad-rank
3	Data width	x4 = 4-bit x8 = 8-bit
4	Memory generation	DDR4

	Description	Definition
5	Maximum memory speed	2133 MT/s
6	CAS latency	P=15
7	DIMM type	R = RDIMM (registered) L = LRDIMM (load reduced)

For more information about product features, specifications, options, configurations, and compatibility, see the product QuickSpecs on the HP website (<http://www.hp.com/go/qs>).

## Memory configurations

To optimize node availability, the node supports the following AMP modes:

- **Advanced ECC**—Provides up to 4-bit error correction and enhanced performance over Lockstep mode. This mode is the default option for this node.
- **Online spare memory**—Provides protection against failing or degraded DIMMs. Certain memory is reserved as spare, and automatic failover to spare memory occurs when the system detects a DIMM that is degrading. This allows DIMMs that have a higher probability of receiving an uncorrectable memory error (which would result in system downtime) to be removed from operation.

Advanced Memory Protection options are configured in the BIOS/Platform Configuration (RBSU). If the requested AMP mode is not supported by the installed DIMM configuration, the node boots in Advanced ECC mode. For more information, see the *HP UEFI System Utilities User Guide for HP ProLiant Gen9 Servers* on the HP website (<http://www.hp.com/go/ProLiantUEFI/docs>).

### Maximum capacity

DIMM type	DIMM rank	One processor	Two processors
RDIMM	Single-rank (4 GB)	32 GB	64 GB
RDIMM	Single-rank (8 GB)	64GB	128 GB
RDIMM	Dual-rank (8 GB)	64 GB	128 GB
RDIMM	Dual-rank (16 GB)	128 GB	256 GB
LRDIMM	Dual-rank (16 GB)	128 GB	256 GB
RDIMM	Dual-rank (32 GB)	256 GB	512 GB
LRDIMM	Quad-rank (32 GB)	256 GB	512 GB

For the latest memory configuration information, see the QuickSpecs on the HP website (<http://www.hp.com/go/qs>).

## Advanced ECC memory configuration

Advanced ECC memory is the default memory protection mode for this node. Standard ECC can correct single-bit memory errors and detect multi-bit memory errors. When multi-bit errors are detected using Standard ECC, the error is signaled to the node and causes the node to halt.

Advanced ECC protects the node against some multi-bit memory errors. Advanced ECC can correct both single-bit memory errors and 4-bit memory errors if all failed bits are on the same DRAM device on the DIMM.

Advanced ECC provides additional protection over Standard ECC because it is possible to correct certain memory errors that would otherwise be uncorrected and result in a node failure. Using HP Advanced

Memory Error Detection technology, the node provides notification when a DIMM is degrading and has a higher probability of uncorrectable memory error.

## Online Spare memory configuration

Online spare memory provides protection against degraded DIMMs by reducing the likelihood of uncorrected memory errors. This protection is available without any operating system support.

Online spare memory protection dedicates one rank of each memory channel for use as spare memory. The remaining ranks are available for OS and application use. If correctable memory errors occur at a rate higher than a specific threshold on any of the non-spare ranks, the node automatically copies the memory contents of the degraded rank to the online spare rank. The node then deactivates the failing rank and automatically switches over to the online spare rank.

## General DIMM slot population guidelines

Observe the following guidelines for all AMP modes:

- Install DIMMs only if the corresponding processor is installed.
- When two processors are installed, balance the DIMMs across the two processors.
- White DIMM slots denote the first slot of a channel (Ch 1-A, Ch 2-B, Ch 3-C, Ch 4-D)
- Do not mix RDIMMs and LRDIMMs.
- When one processor is installed, install DIMMs in sequential alphabetic order: A, B, C, D, E, F, and so forth.
- When two processors are installed, install the DIMMs in sequential alphabetic order balanced between the two processors: P1-A, P2-A, P1-B, P2-B, P1-C, P2-C, and so forth.
- When single-rank, dual-rank, and quad-rank DIMMs are populated for two DIMMs per channel or three DIMMs per channel, always populate the higher number rank DIMM first (starting from the farthest slot). For example, first quad-rank DIMM, then dual-rank DIMM, and then lastly single-rank DIMM.
- DIMMs should be populated starting farthest from the processor on each channel.
- For DIMM spare replacement, install the DIMMs per slot number as instructed by the system software.

For more information about node memory, see the HP website (<http://www.hp.com/go/memory>).

DIMM speeds are supported as indicated in the following table.

Populated slots (per channel)	Rank	Speeds supported (MT/s)
1	Single-, dual-, or quad-rank	2133
2	Single- or dual-rank	2133

## Advanced ECC population guidelines

For Advanced ECC mode configurations, observe the following guidelines:

- Observe the general DIMM slot population guidelines.
- DIMMs may be installed individually.

## Online spare population guidelines

For Online Spare memory mode configurations, observe the following guidelines:

- Observe the general DIMM slot population guidelines.
- Each channel must have a valid online spare configuration.
- Each channel can have a different valid online spare configuration.
- Each populated channel must have a spare rank. A single dual-rank DIMM is not a valid configuration.

## Population order

For memory configurations with a single processor or multiple processors, DIMMs must be populated sequentially in alphabetical order (A through H).

After installing the DIMMs, use the BIOS/Platform Configuration (RBSU) in the UEFI System Utilities to configure supported AMP modes.

## Installing a DIMM

1. Power down the node (on page 31).
2. Disconnect all peripheral cables from the node.
3. Remove the node from the chassis (on page 32).
4. Place the node on a flat, level surface.
5. If installed in a 2U node, remove the FlexibleLOM 2U node riser cage assembly ("FlexibleLOM 2U node riser cage assembly" on page 52).
6. If installed in a 2U node, remove the three-slot PCI riser cage assembly ("Three-slot PCI riser cage assemblies" on page 53).
7. Remove the air baffle (on page 41).
8. Open the DIMM slot latches.
9. Install the DIMM.

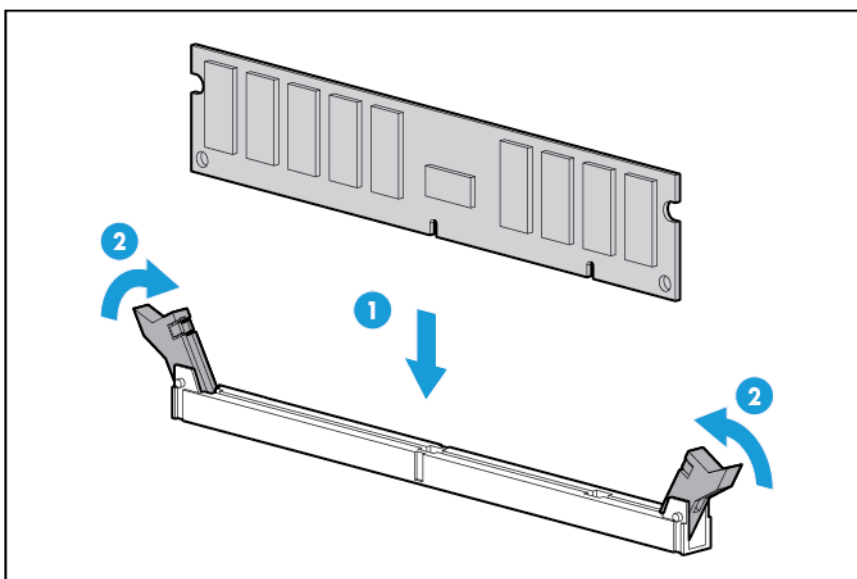

10. Install the air baffle (on page 42).

11. Install any removed PCI riser cage assemblies ("PCI riser cage assembly options" on page 84).
12. Install the node into the chassis ("Installing a node into the chassis" on page 60).
13. Connect all peripheral cables to the nodes.
14. Power up the node ("Power up the nodes" on page 31).

## Storage cable options

### B140i 1U node SATA cable

For more information about product features, specifications, options, configurations, and compatibility, see the product QuickSpecs on the HP website (<http://www.hp.com/go/qs>).

To install the component:

1. Power down the node (on page 31).
2. Disconnect all peripheral cables from the node.
3. Remove the server node from the chassis ("Remove the node from the chassis" on page 32).
4. Place the node on a flat, level surface.
5. Remove the bayonet board assembly from the node ("Remove the bayonet board assembly" on page 43).
6. Remove the bayonet board bracket from the bayonet board ("Remove the bayonet board bracket" on page 46).
7. Connect the SATA cable to the system board and bayonet board.

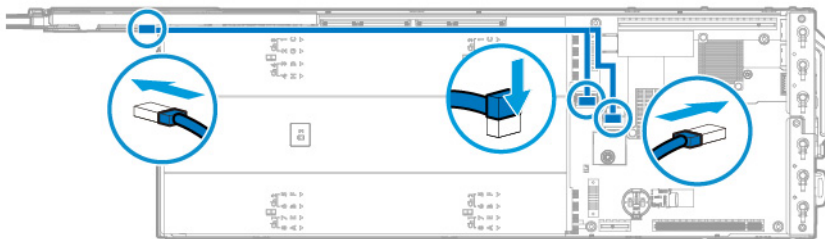

8. Install the bayonet board bracket onto the bayonet board ("Install the bayonet board bracket" on page 47).
9. Route and secure the cable under the thin plastic covers.
10. Install the bayonet board assembly into the node ("Install the bayonet board assembly" on page 44)..
11. Install the node into the chassis ("Installing a node into the chassis" on page 60).
12. Connect all peripheral cables to the nodes.
13. Power up the node ("Power up the nodes" on page 31).

## B140i 2U node SATA cable

For more information about product features, specifications, options, configurations, and compatibility, see the product QuickSpecs on the HP website (<http://www.hp.com/go/qs>).

To install the component:

1. Power down the node (on page 31).
2. Disconnect all peripheral cables from the node.
3. Remove the server node from the chassis ("Remove the node from the chassis" on page 32).
4. Place the node on a flat, level surface.
5. If installed, remove the FlexibleLOM 2U node riser cage assembly ("FlexibleLOM 2U node riser cage assembly" on page 52).
6. If installed, remove the three-slot PCI riser cage assembly ("Three-slot PCI riser cage assemblies" on page 53).
7. If a graphic card/ coprocessor power cable is installed, disconnect it from the bayonet board.
8. Remove the bayonet board assembly from the node ("Remove the bayonet board assembly" on page 43).
9. Remove the bayonet board bracket from the bayonet board ("Remove the bayonet board bracket" on page 46).
10. Connect the SATA cable to the system board and bayonet board.

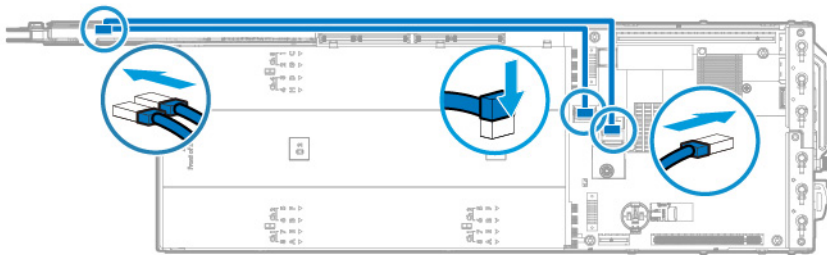

11. Route the cable under the padding on the 2U bayonet board and install the bayonet board bracket onto the bayonet board ("Install the bayonet board bracket" on page 47).
12. Route and secure the cable under the thin plastic covers.
13. Install the bayonet board assembly into the node ("Install the bayonet board assembly" on page 44).
14. If removed, connect the graphic card/ coprocessor cable to the bayonet board.
15. Install any removed PCI riser cage assemblies ("PCI riser cage assembly options" on page 84).
16. Install the node into the chassis ("Installing a node into the chassis" on page 60).
17. Connect all peripheral cables to the nodes.
18. Power up the node ("Power up the nodes" on page 31).

# Mini-SAS H240 1U node cable option

In a 1U node, the HP H240 host bus adapter can only be installed in the single-slot left PCI riser cage assembly.

For more information about product features, specifications, options, configurations, and compatibility, see the product QuickSpecs on the HP website (<http://www.hp.com/go/qs>).

To install the component:

1. Power down the node (on page 31).
2. Disconnect all peripheral cables from the node.
3. Remove the server node from the chassis ("Remove the node from the chassis" on page 32).
4. Place the node on a flat, level surface.
5. Do one of the following:
  - o Remove the 1U left rear I/O blank (on page 38).
  - o Remove the single-slot left PCI riser cage assembly (on page 48).
6. If a B140i SATA cable is installed, disconnect it from the connectors on the system board.
7. Remove the bayonet board assembly from the node ("Remove the bayonet board assembly" on page 43).
8. Remove the bayonet board bracket from the bayonet board ("Remove the bayonet board bracket" on page 46).
9. If installed, disconnect and remove the B140i 1U node SATA cable.
10. Remove the PCI slot blank.
11. Install the host bus adapter into the riser cage assembly and secure it with one T-10 screw.
12. Connect the split ends of the Mini-SAS Y-cable to the host bus adapter.
13. Connect the common end of the Mini-SAS Y-cable to the bayonet board.

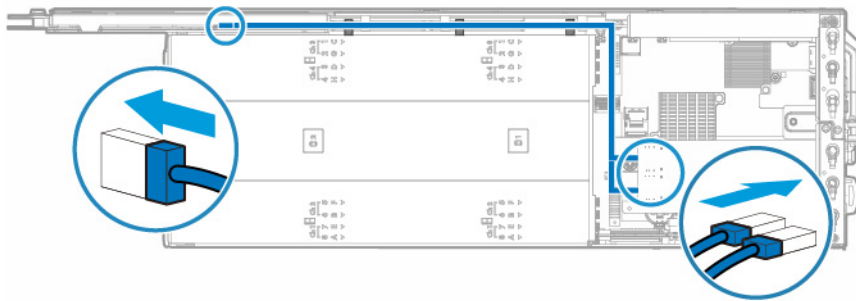

14. Install the bayonet board bracket onto the bayonet board ("Install the bayonet board bracket" on page 47).
15. Route and secure the cable under the thin plastic covers.
16. Install the bayonet board assembly into the node ("Install the bayonet board assembly" on page 44).
17. Install the single-slot left PCI riser cage assembly ("Single-slot left PCI riser cage assembly option" on page 85).
18. Install the node into the chassis ("Installing a node into the chassis" on page 60).



19. Connect all peripheral cables to the nodes.
20. Power up the node ("Power up the nodes" on page 31).

## Mini-SAS H240 2U node cable option

In a 2U node, the HP H240 host bus adapter can only be installed in the single-slot left PCI riser cage assembly or the single-slot 2U node PCI riser cage assembly.

For more information about product features, specifications, options, configurations, and compatibility, see the product QuickSpecs on the HP website (<http://www.hp.com/go/qs>).

To install the component:

1. Power down the node (on page 31).
2. Disconnect all peripheral cables from the node.
3. Remove the server node from the chassis ("Remove the node from the chassis" on page 32).
4. Place the node on a flat, level surface.
5. Do one of the following:
  - o Remove the 2U rear I/O blank (on page 40).
  - o Remove the single-slot 2U node PCI riser cage assembly (on page 51).
  - o Remove the single-slot left PCI riser cage assembly (on page 48).
6. If a B140i SATA cable is installed, disconnect it from the connectors on the system board.
7. Remove the bayonet board assembly from the node ("Remove the bayonet board assembly" on page 43).
8. Remove the bayonet board bracket from the bayonet board ("Remove the bayonet board bracket" on page 46).
9. If installed, disconnect and remove the B140i 2U node SATA cable.
10. Remove riser slot blank from riser cage.
11. Install the host bus adapter into the riser cage assembly and secure it with one T-10 screw.
12. Connect the Mini-SAS cable to the host bus adapter.
13. Connect the opposite ends of the cable assembly to the bayonet board.



14. Route the cable under the padding on the 2U bayonet board and install the bayonet board bracket onto the bayonet board ("Install the bayonet board bracket" on page 47).
15. Route and secure the cable under the thin plastic covers.
16. Install the bayonet board assembly into the node ("Install the bayonet board assembly" on page 44).

17. Install the PCI riser cage assemblies ("PCI riser cage assembly options" on page 84).
18. Install the node into the chassis ("Installing a node into the chassis" on page 60).
19. Connect all peripheral cables to the nodes.
20. Power up the node ("Power up the nodes" on page 31).

## Mini-SAS P440/P840 cable option

In a 1U node, the HP P440 Smart Array controller must be installed in the single-slot left PCI riser cage assembly.

To install an HP P840 Smart Array controller in a 2U node, two P440/P840 Mini-SAS cable options are required. The HP P840 Smart Array controller can only be installed in slot 2 of FlexibleLOM 2U node riser cage assembly or slot 3 of a three-slot PCI riser cage assembly. For more information on the riser board slot specifications, see "PCIe riser board slot definitions (on page 27)."

For more information about product features, specifications, options, configurations, and compatibility, see the product QuickSpecs on the HP website (<http://www.hp.com/go/qs>).

To install the component:

1. Power down the node (on page 31).
2. Disconnect all peripheral cables from the node.
3. Remove the server node from the chassis ("Remove the node from the chassis" on page 32).
4. Place the node on a flat, level surface.
5. If installing an HP P440 Smart Array controller, do one of the following:
  - o Remove the 1U left rear I/O blank (on page 38).
  - o Remove the single-slot left PCI riser cage assembly (on page 48).
6. If installing a HP P840 Smart Array controller, do one of the following:
  - o Remove the 2U rear I/O blank (on page 40).
  - o Remove the FlexibleLOM 2U node riser cage assembly (on page 52).
  - o Remove the three-slot PCI riser cage assembly ("Three-slot PCI riser cage assemblies" on page 53).
7. If a B140i SATA cable is installed, disconnect it from the connectors on the system board.
8. Remove the bayonet board assembly from the node ("Remove the bayonet board assembly" on page 43).
9. Remove the bayonet board bracket from the bayonet board ("Remove the bayonet board bracket" on page 46).
10. If installed, disconnect and remove the B140i 1U node SATA cable or the B140i 2U node SATA cable.
11. Remove the PCI slot blank.
12. Install the HP P440 Smart array controller or HP P840 Smart Array controller into the riser cage assembly and secure it with one T-10 screw ("Controller options" on page 96).

13. Connect the Mini-SAS cable to the Smart Storage controller and the bayonet board.



HP P840 Smart Array controller in a 2U node

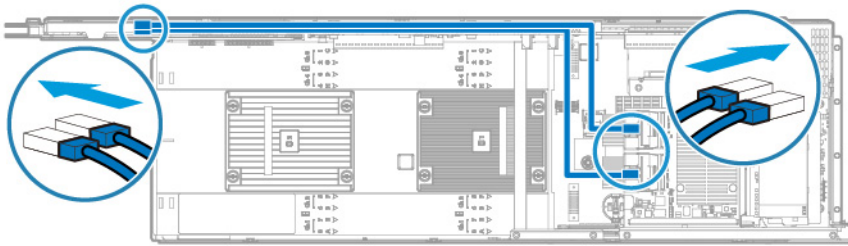

14. In a 1U node, do the following:
  - a. Install the bayonet board bracket onto the bayonet board ("Install the bayonet board bracket" on page 47).
  - b. Route and secure the cable under the thin plastic covers.
15. In a 2U node, do the following:
  - a. Route the cables under the padding on the 2U bayonet board and install the bayonet board bracket onto the bayonet board ("Install the bayonet board bracket" on page 47).
  - b. Route and secure the cables under the thin plastic covers.
16. Install the bayonet board assembly into the node ("Install the bayonet board assembly" on page 44).
17. Install the PCI riser cage assembly. ("PCI riser cage assembly options" on page 84)
18. Install the node into the chassis ("Installing a node into the chassis" on page 60).
19. Connect all peripheral cables to the node.
20. Power up the node ("Power up the nodes" on page 31).

## Mini-SAS P440 2U node cable option

In a 2U node, the HP P440 Smart Array controller can only be installed in the single-slot left PCI riser cage assembly or the single-slot 2U node PCI riser cage assembly.

For more information about product features, specifications, options, configurations, and compatibility, see the product QuickSpecs on the HP website (<http://www.hp.com/go/qs>).

To install the component:

1. Power down the node (on page 31).
2. Disconnect all peripheral cables from the node.
3. Remove the server node from the chassis ("[Remove the node from the chassis](#)" on page 32).
4. Place the node on a flat, level surface.
5. Do one of the following:
  - o Remove the 2U rear I/O blank (on page 40).
  - o Remove the FlexibleLOM 2U node riser cage assembly (on page 52).
  - o Remove the three-slot PCI riser cage assembly ("[Three-slot PCI riser cage assemblies](#)" on page 53).
6. Remove the bayonet board assembly from the node ("[Remove the bayonet board assembly](#)" on page 43).
7. Remove the bayonet board bracket from the bayonet board ("[Remove the bayonet board bracket](#)" on page 46).
8. If installed, disconnect and remove the B140i 2U node SATA cable.
9. Remove the PCI slot blank.
10. Install the HP P440 Smart Array controller into the riser cage assembly and secure it with one T-10 screw ("[Controller options](#)" on page 96).
11. Connect the Mini-SAS cable to the Smart Storage controller and the bayonet board.



12. Route the cable under the padding on the 2U bayonet board and install the bayonet board bracket onto the bayonet board ("[Install the bayonet board bracket](#)" on page 47).
13. Route and secure the cable under the thin plastic covers.
14. Install the bayonet board assembly into the node ("[Install the bayonet board assembly](#)" on page 44).
15. Install the PCI riser cage assembly.
16. Install the node into the chassis ("[Installing a node into the chassis](#)" on page 60).
17. Connect all peripheral cables to the nodes.
18. Power up the node ("[Power up the nodes](#)" on page 31).

## PCI riser cage assembly options

Each node supports two PCI riser cage assembly options. A second processor is required to support installation of the single-slot 1U node right PCI riser cage assembly or a three-slot PCI riser cage assembly. For more information on the riser board slot specifications, see PCIe riser board slot definitions (on page 27).

In a 2U node, a three-slot PCI riser cage assembly must be installed with the single-slot left PCI riser cage assembly. The FlexibleLOM 2U riser cage assembly must be installed with the single-slot 2U node PCI riser cage assembly.

For more information about product features, specifications, options, configurations, and compatibility, see the product QuickSpecs on the HP website (<http://www.hp.com/go/qs>).

## Single-slot left PCI riser cage assembly option

To install the component:

1. Power down the node (on page 31).
2. Disconnect all peripheral cables from the node.
3. Remove the server node from the chassis ("Remove the node from the chassis" on page 32).
4. Place the node on a flat, level surface.
5. Do one of the following:
  - o Remove the 1U left rear I/O blank (on page 38).
  - o Remove the 2U rear I/O blank (on page 40).
6. If you are installing an expansion board, remove the PCI blank.

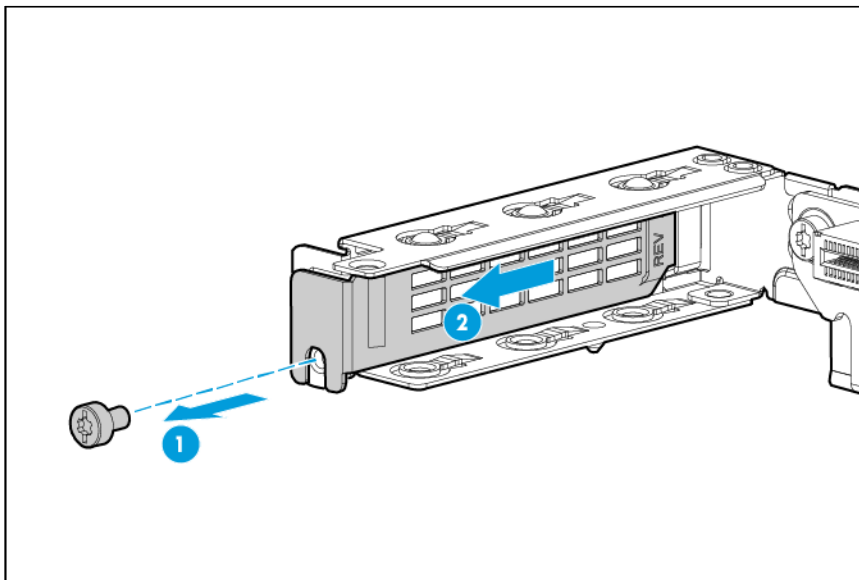

7. Install any optional expansion boards.
8. Connect all necessary internal cabling to the expansion board. For more information on these cabling requirements, see the documentation that ships with the option.

9. In a 1U node, install the single-slot left PCI riser cage assembly and then secure it with three T-10 screws.

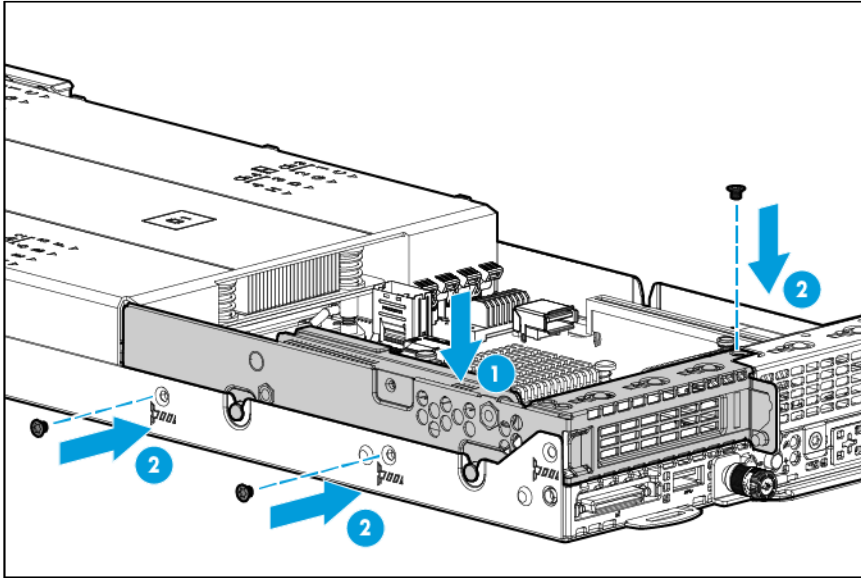

10. In a 2U node, do the following:

- a. Install the single-slot left PCI riser cage assembly and then secure it with two T-10 screws.

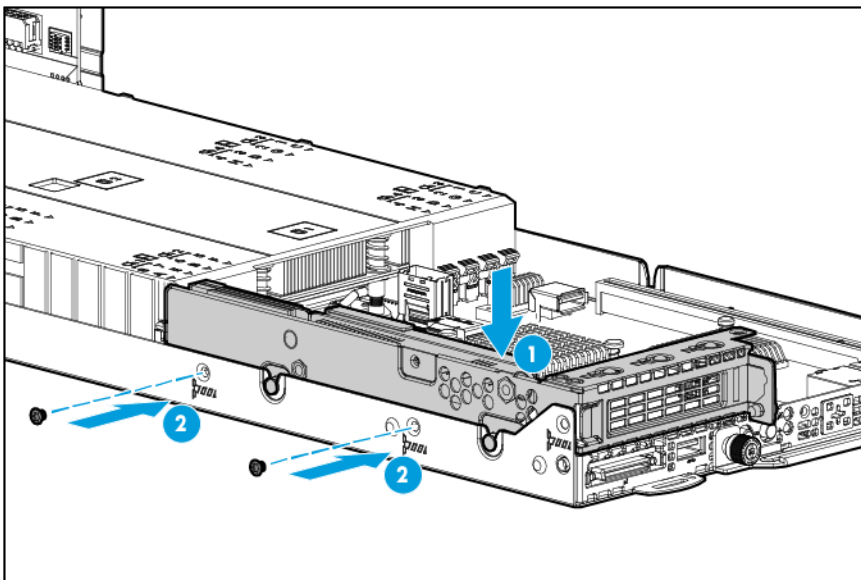

- b. Install the three-slot riser cage assembly ("[Three-slot PCI riser cage assembly options](#)" on page 93).



**IMPORTANT:** If the PCIe riser cage assembly is not seated properly, then the server does not power up.



**CAUTION:** To prevent improper cooling and thermal damage, do not operate the node unless all PCI riser cages or rear I/O blanks are installed, and do not operate the node unless all PCI slots have either an expansion slot cover or an expansion board installed.

11. Install the node into the chassis ("[Installing a node into the chassis](#)" on page 60).
12. Connect all peripheral cables to the nodes.
13. Power up the node ("[Power up the nodes](#)" on page 31).

## Single-slot 1U node right PCI riser cage assembly option

To install the component:

1. Power down the node (on page 31).
2. Disconnect all peripheral cables from the node.
3. Remove the server node from the chassis ("Remove the node from the chassis" on page 32).
4. Place the node on a flat, level surface.
5. Do one of the following:
  - o Remove the 1U left rear I/O blank (on page 38).
  - o Remove the single-slot left PCI riser cage assembly (on page 48).
6. Remove the 1U right rear I/O blank (on page 39).
7. If you are installing an expansion board, remove the PCI blank.

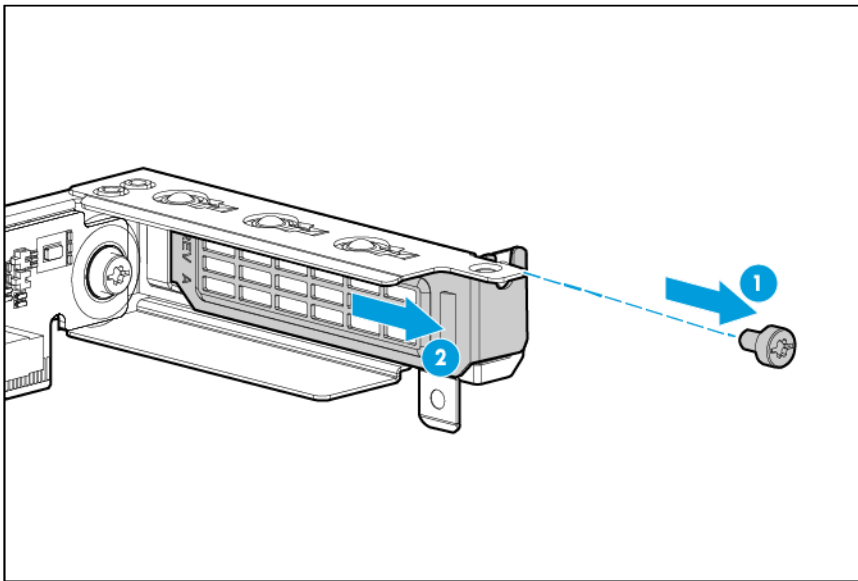

8. Install any optional expansion boards into the PCI riser cage assembly.
9. Connect all necessary internal cabling to the expansion board. For more information on these cabling requirements, see the documentation that ships with the option.

10. Install the PCI riser cage assembly.

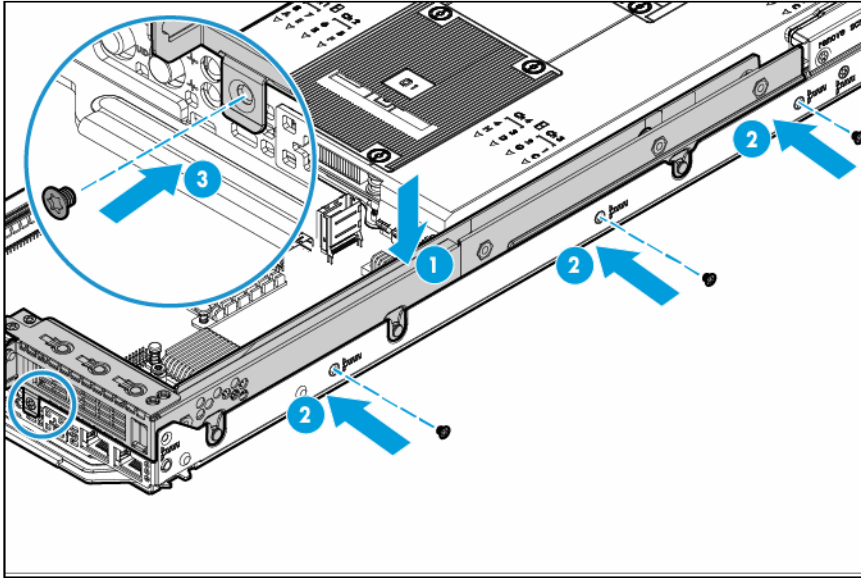

11. Do one of the following:

- Install the 1U left rear I/O blank (on page 38).
- Install the single-slot left PCI riser cage assembly ("[Single-slot left PCI riser cage assembly option](#)" on page 85).



**CAUTION:** To prevent improper cooling and thermal damage, do not operate the node unless all PCI riser cages or rear I/O blanks are installed, and do not operate the node unless all PCI slots have either an expansion slot cover or an expansion board installed.



**IMPORTANT:** If the PCIe riser cage assembly is not seated properly, then the server does not power up.

12. Install the node into the chassis ("[Installing a node into the chassis](#)" on page 60).
13. Connect all peripheral cables to the nodes.
14. Power up the node ("[Power up the nodes](#)" on page 31).

## Single-slot 2U node PCI riser cage assembly option

To install the component:

1. Power down the node (on page 31).
2. Disconnect all peripheral cables from the node.
3. Remove the server node from the chassis ("[Remove the node from the chassis](#)" on page 32).
4. Place the node on a flat, level surface.
5. Remove the 2U rear I/O blank (on page 40).



6. If you are installing an expansion board, remove the PCI blank.

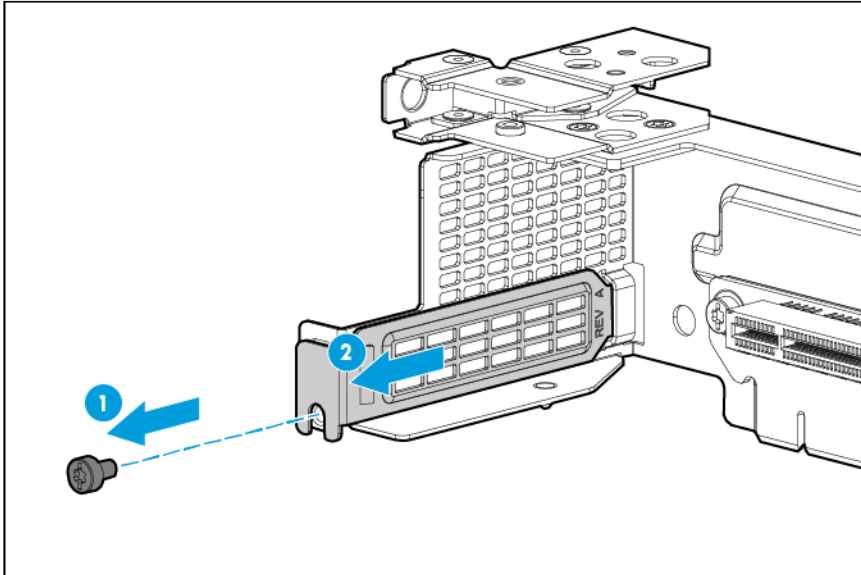

7. Install any optional expansion boards.
8. Connect all necessary internal cabling to the expansion board. For more information on these cabling requirements, see the documentation that ships with the option.
9. Do the following:
  - a. Install the single-slot 2U node PCI riser cage assembly and secure it with two T-10 screws.
  - b. Install the FlexibleLOM 2U node riser cage assembly and secure it with five T-10 screws.

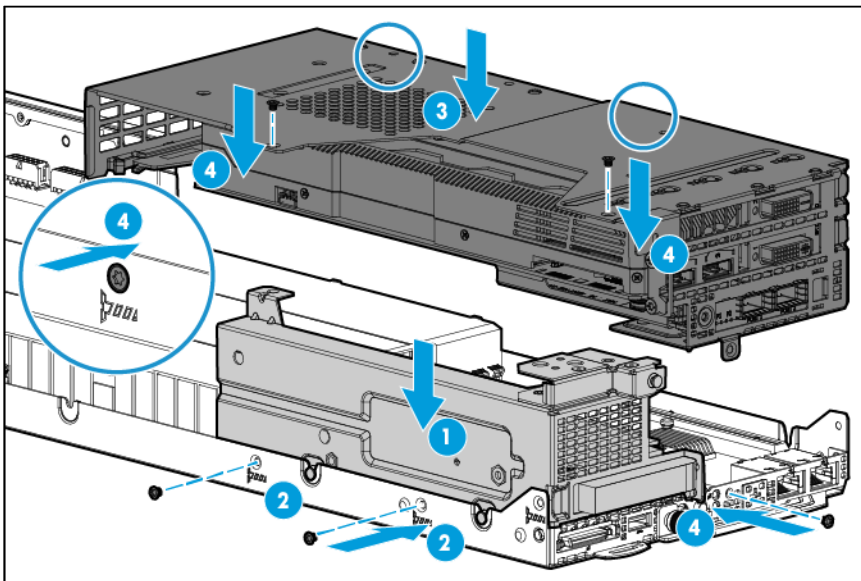

**CAUTION:** To prevent improper cooling and thermal damage, do not operate the node unless all PCI riser cages or rear I/O blanks are installed, and do not operate the node unless all PCI slots have either an expansion slot cover or an expansion board installed.



**IMPORTANT:** If the PCIe riser cage assembly is not seated properly, then the server does not power up.

10. Install the node into the chassis ("[Installing a node into the chassis](#)" on page 60).
11. Connect all peripheral cables to the nodes.
12. Power up the node ("[Power up the nodes](#)" on page 31).

## FlexibleLOM 1U node riser cage assembly option

To install the component:

1. Power down the node (on page 31).
2. Disconnect all peripheral cables from the node.
3. Remove the server node from the chassis ("[Remove the node from the chassis](#)" on page 32).
4. Place the node on a flat, level surface.
5. Do one of the following:
  - o Remove the 1U left rear I/O blank (on page 38).
  - o Remove the single-slot left PCI riser cage assembly (on page 48).
6. Remove the 1U right rear I/O blank (on page 39).
7. Remove the PCI blank.

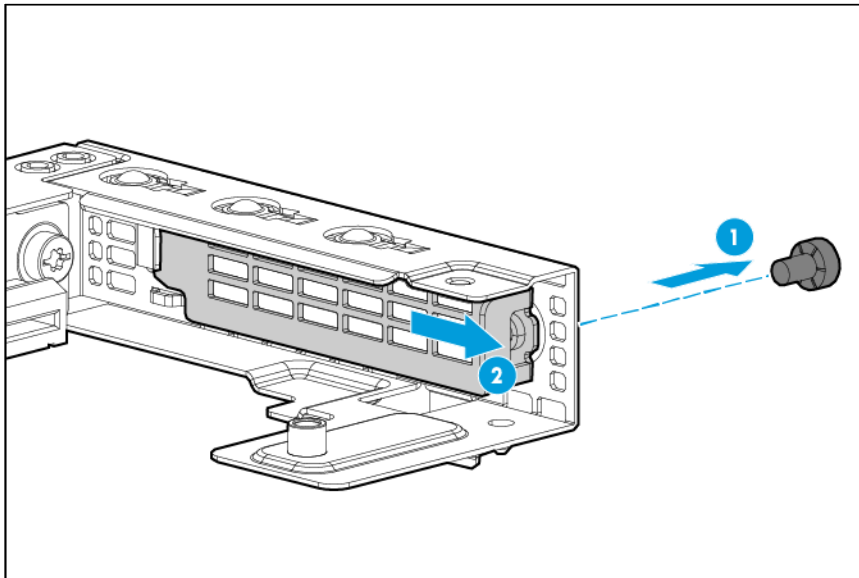

8. Install the FlexibleLOM adapter.

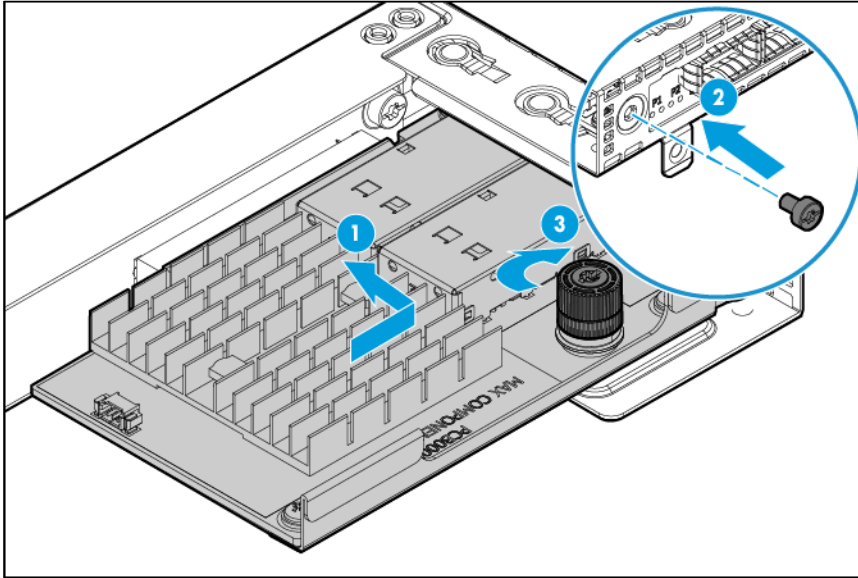

9. Install the FlexibleLOM riser cage assembly.

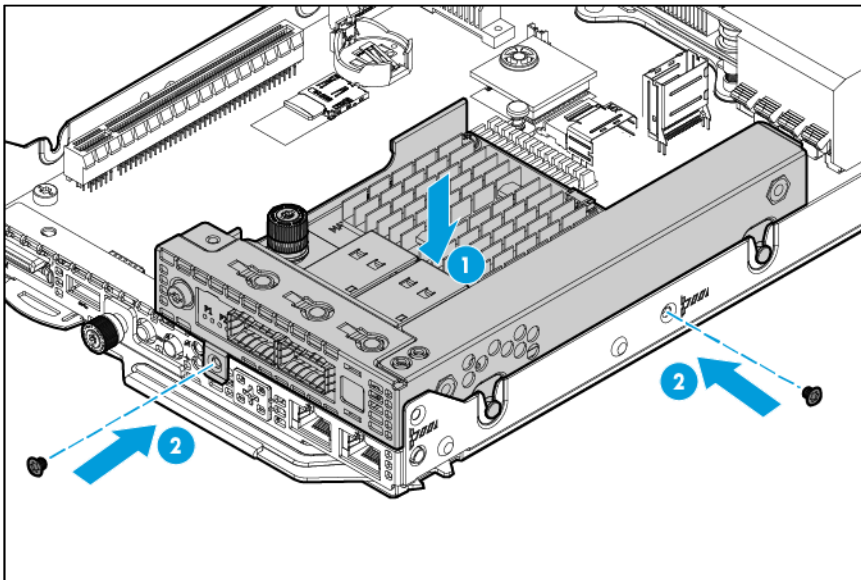

10. Do one of the following:

- Install the 1U left rear I/O blank (on page 38).
- Install the single-slot left PCI riser cage assembly ("[Single-slot left PCI riser cage assembly option](#)" on page 85).



**CAUTION:** To prevent improper cooling and thermal damage, do not operate the node unless all PCI riser cages or rear I/O blanks are installed, and do not operate the node unless all PCI slots have either an expansion slot cover or an expansion board installed.



**IMPORTANT:** If the PCIe riser cage assembly is not seated properly, then the server does not power up.

11. Install the node into the chassis ("[Installing a node into the chassis](#)" on page 60).

12. Connect all peripheral cables to the nodes.
13. Power up the node ("Power up the nodes" on page 31).

## FlexibleLOM 2U node riser cage assembly option

To install the component:

1. Power down the node (on page 31).
2. Disconnect all peripheral cables from the node.
3. Remove the server node from the chassis ("Remove the node from the chassis" on page 32).
4. Place the node on a flat, level surface.
5. Remove 2U rear I/O blank ("Remove the 2U rear I/O blank" on page 40).
6. Remove the PCI blank.

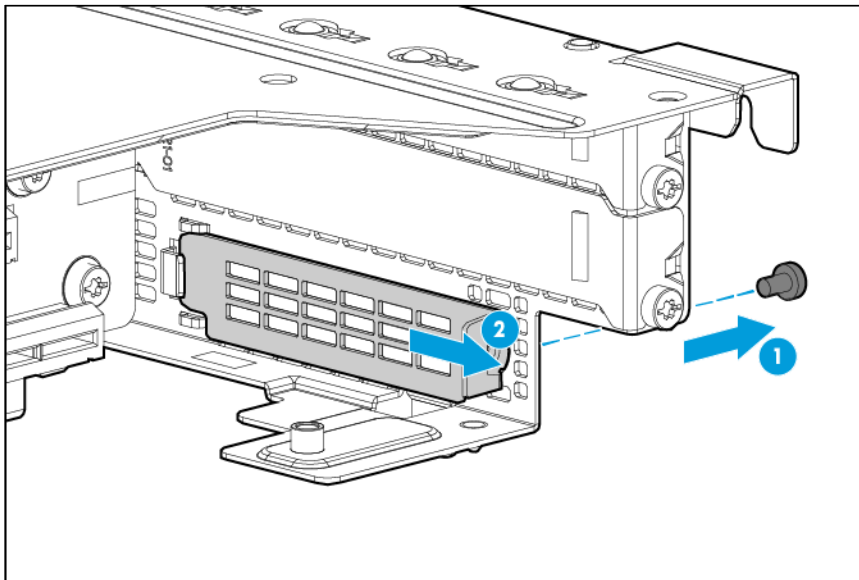

7. Install the FlexibleLOM adapter.

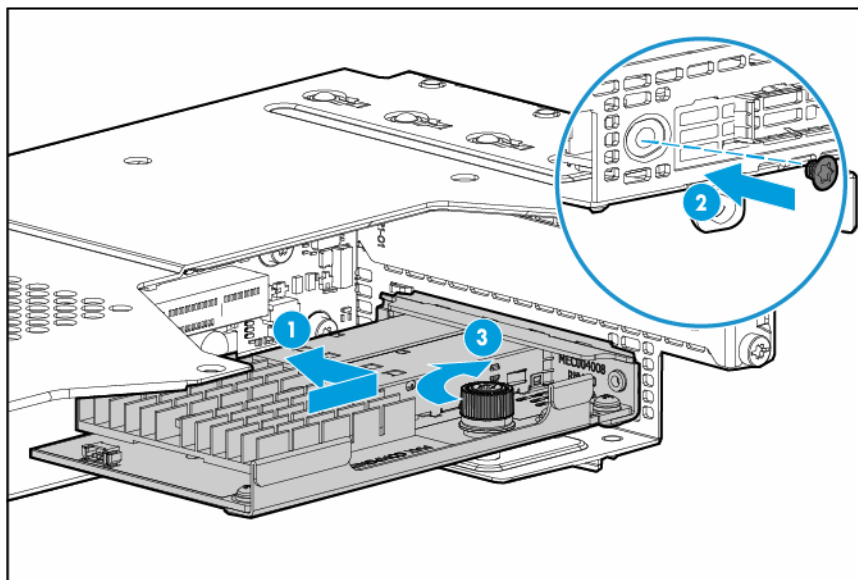

8. Do the following:
  - a. Install the single-slot 2U node PCI riser cage assembly and secure it with two T-10 screws.
  - b. Install the FlexibleLOM 2U node riser cage assembly and secure it with five T-10 screws.

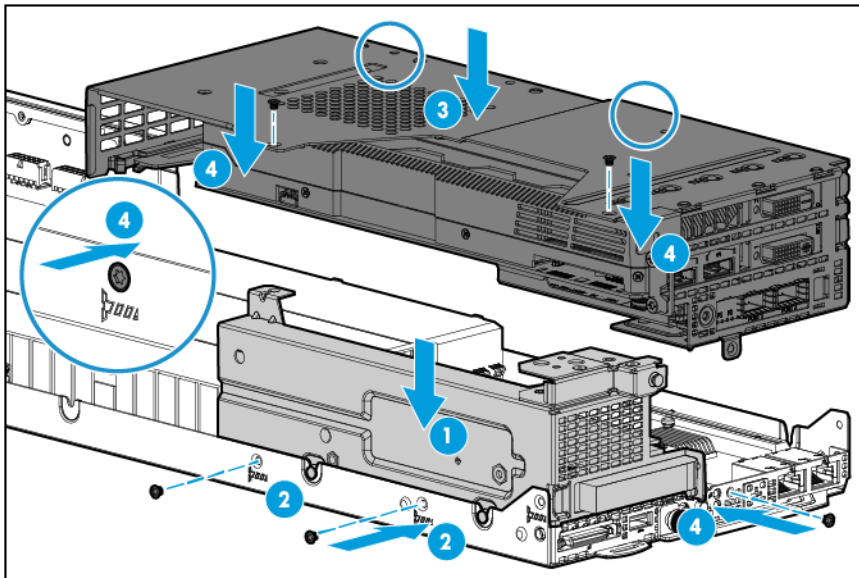

**CAUTION:** To prevent improper cooling and thermal damage, do not operate the node unless all PCI riser cages or rear I/O blanks are installed, and do not operate the node unless all PCI slots have either an expansion slot cover or an expansion board installed.

**IMPORTANT:** If the PCIe riser cage assembly is not seated properly, then the server does not power up.

9. Install the node into the chassis ("Installing a node into the chassis" on page 60).
10. Connect all peripheral cables to the nodes.
11. Power up the node ("Power up the nodes" on page 31).

## Three-slot PCI riser cage assembly options

**NOTE:** The three-slot PCI riser cage assembly and the three-slot GPU-direct PCI riser cage assembly, share the same riser cage but have a different riser board. For more information on the riser board slot specifications, see "PCIe riser board slot definitions (on page 27)."

To install the component:

1. Power down the node (on page 31).
2. Disconnect all peripheral cables from the node.
3. Remove the server node from the chassis ("Remove the node from the chassis" on page 32).
4. Place the node on a flat, level surface.
5. Remove the 2U rear I/O blank (on page 40).

6. Install the single-slot left PCI riser cage assembly and then secure it with two T-10 screws.

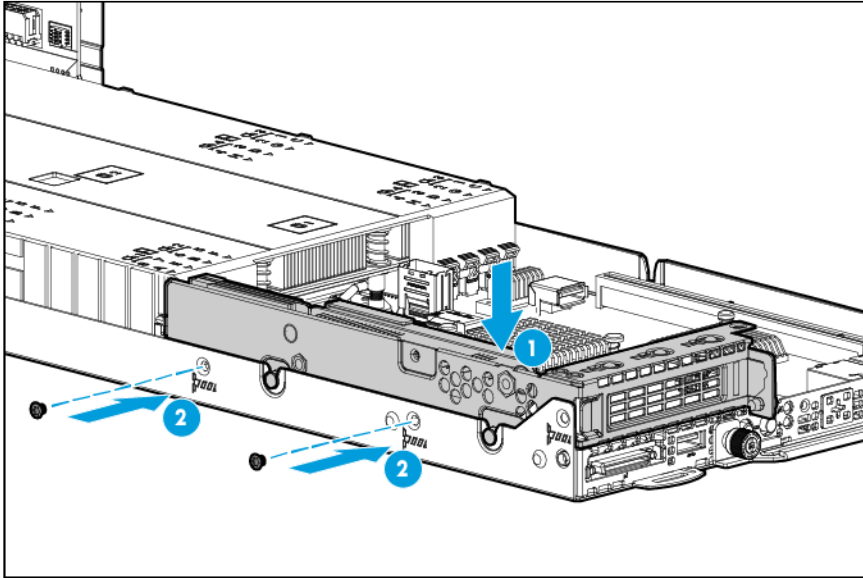

7. If installing an expansion board, do the following:

- a. Remove the riser cage bracket.

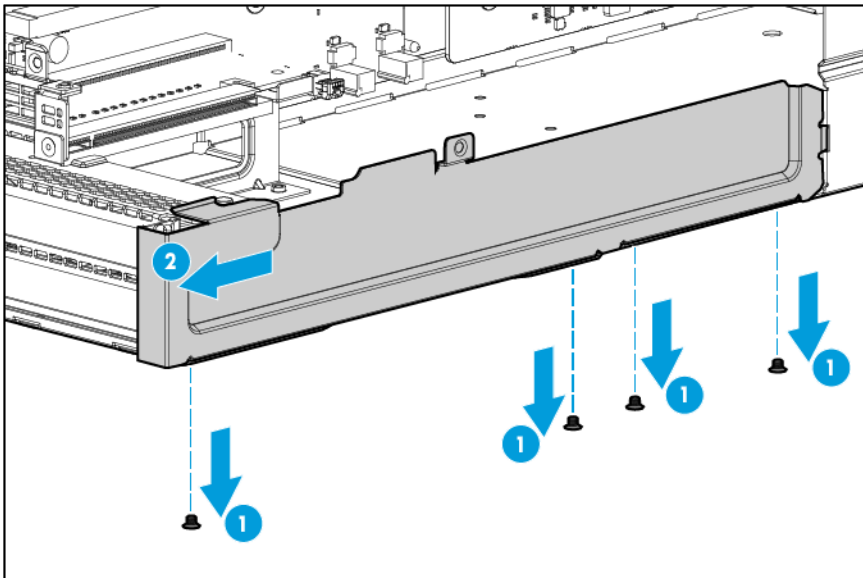

- b. Select the appropriate PCIe slot and remove any PCI blanks.

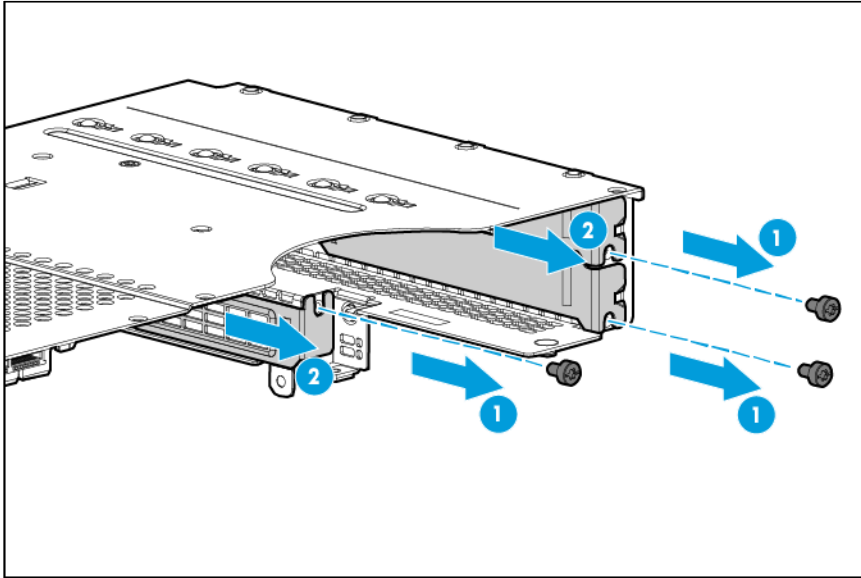

8. Install any optional expansion boards.
9. Connect all necessary internal cables to the expansion board. For more information on these cabling requirements, see the documentation that ships with the option.
10. Install the riser cage bracket.

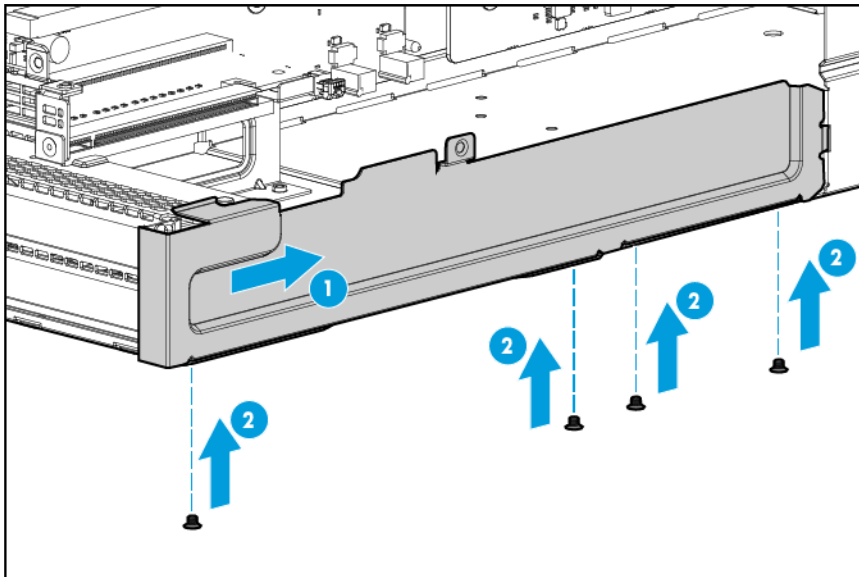

11. Install the three-slot riser cage assembly and then secure it with six T-10 screws.

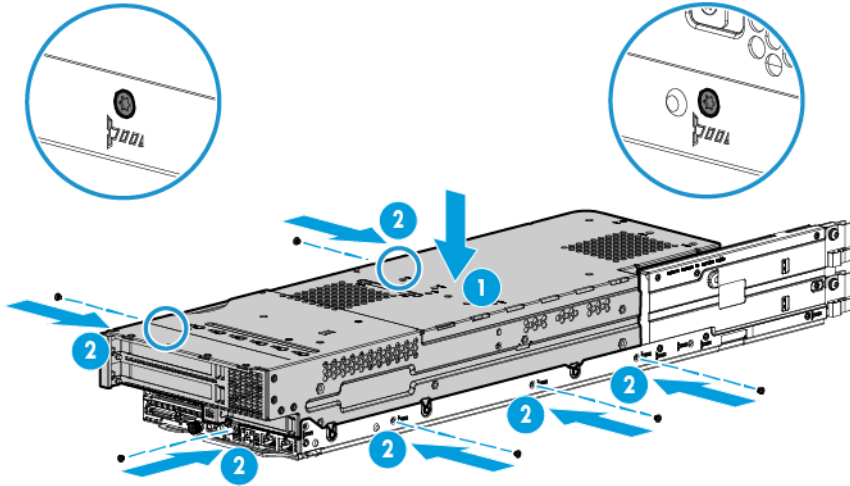

**CAUTION:** To prevent improper cooling and thermal damage, do not operate the node unless all PCI riser cages or rear I/O blanks are installed, and do not operate the node unless all PCI slots have either an expansion slot cover or an expansion board installed.



**IMPORTANT:** If the PCIe riser cage assembly is not seated properly, then the server does not power up.

12. Install the node into the chassis ("Installing a node into the chassis" on page 60).
13. Connect all peripheral cables to the nodes.
14. Power up the node ("Power up the nodes" on page 31).

## Controller options

The node ships with an embedded HP Dynamic Smart Array B140i Controller. For more information about the controller and its features, see the *HP Dynamic Smart Array B140i RAID Controller User Guide* on the HP website (<http://www.hp.com/go/smartstorage/docs>).

Upgrade options exist for an integrated array controller. For a list of supported options, see the product QuickSpecs on the HP website (<http://www.hp.com/go/qs>).

To configure arrays, see the *HP Smart Storage Administrator User Guide* on the HP website (<http://www.hp.com/go/smartstorage/docs>).

The node supports FBWC. FBWC consists of a cache module and an HP Smart Storage Battery Pack. The DDR cache module buffers and stores data being written by an integrated Gen9 P-series Smart Array Controller.



**CAUTION:** The cache module connector does not use the industry-standard DDR3 mini-DIMMs. Do not use the controller with cache modules designed for other controller models, because the controller can malfunction and you can lose data. Also, do not transfer this cache module to an unsupported controller model, because you can lose data.



- 
- △ **CAUTION:** To prevent a node malfunction or damage to the equipment, do not add or remove the battery pack while an array capacity expansion, RAID level migration, or stripe size migration is in progress.
- 
- △ **CAUTION:** After the node is powered down, wait for 30 seconds, and then check the amber LED before unplugging the cable from the cache module. If the amber LED flashes after 30 seconds, do not remove the cable from the cache module. The cache module is backing up data. Data will be lost if the cable is detached when the amber LED is still flashing.
- 

## Storage controller installation guidelines

To maintain optimal thermal conditions and efficiency, HP recommends the following guidelines:

- Install one storage controller per node.
- Install the HP H240 host bus adapter in the single-slot left PCI riser cage assembly or the single-slot 2U node PCI riser cage assembly.
- Install the HP P440 Smart Array controller in the single-slot left PCI riser cage assembly or the single-slot 2U node PCI riser cage assembly.
- Install the HP P840 Smart Array controller in slot 2 of the FlexibleLOM 2U node riser cage assembly or slot 3 of a three-slot PCI riser cage assembly.

For more information about product features, specifications, options, configurations, and compatibility, see the product QuickSpecs on the HP website (<http://www.hp.com/go/qs>).

## Installing the storage controller and FBWC module options

To install the component:

1. Power down the node (on page 31).
2. Disconnect all peripheral cables from the node.
3. Remove the node from the chassis (on page 32).
4. Place the node on a flat, level surface.
5. Open the latch on the controller.

6. Connect the cache module backup power cable to the module.

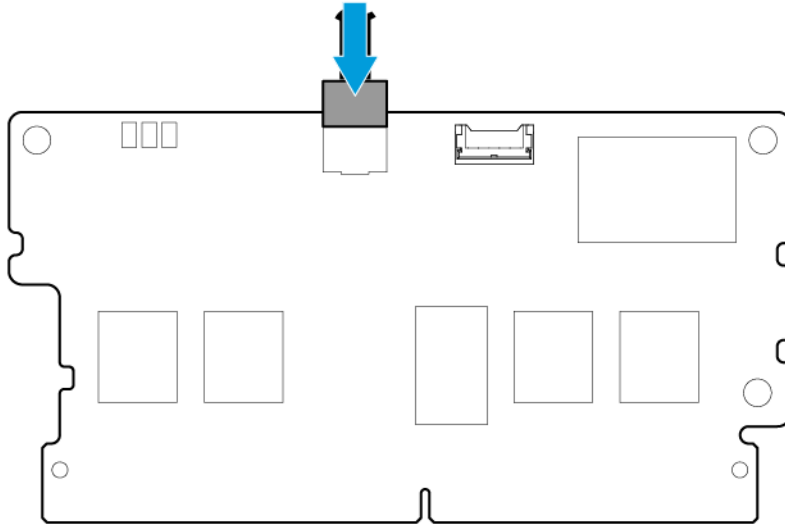

7. Install the cache module on the storage controller.

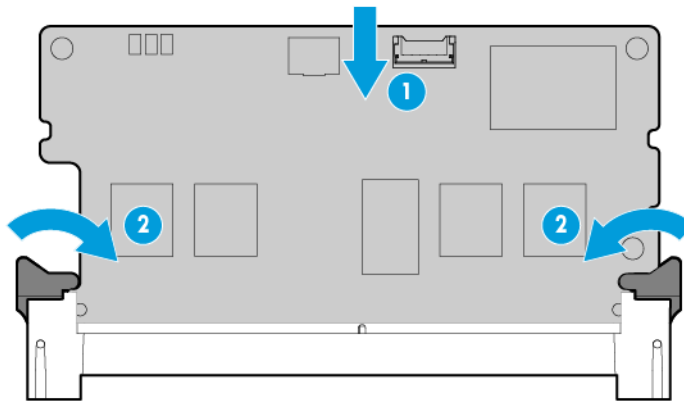

8. Remove the PCI riser cage ("[Remove the PCI riser cage assembly](#)" on page 48).
9. Select the appropriate PCIe slot and remove any PCI blanks.
10. If you installed a cache module on the storage controller, connect the cache module backup power cable to the riser board ("[FBWC module cabling](#)" on page 140).
11. Install the storage controller into the riser cage assembly and secure it to the riser cage with one T-10 screw.
12. Connect all necessary internal cables to the storage controller. For internal drive cabling information, see "[Storage cabling](#)" (on page 137)."
13. Install the PCI riser cage ("[PCI riser cage assembly options](#)" on page 84).
14. Install the node into the chassis ("[Installing a node into the chassis](#)" on page 60).
15. Connect all peripheral cables to the nodes.
16. Power up the node ("[Power up the nodes](#)" on page 31).

For more information about the integrated storage controller and its features, select the relevant user documentation on the HP website (<http://www.hp.com/go/smartstorage/docs>).

To configure arrays, see the *HP Smart Storage Administrator User Guide* on the HP website (<http://www.hp.com/go/smartstorage/docs>).

## Installing the HP Smart Storage Battery

To install the component:

1. Power down the system (on page 31).
2. Disconnect all peripheral cables from the nodes and chassis.
3. Remove all nodes from the chassis ("Remove the node from the chassis" on page 32).
4. If installed, remove the security bezel (on page 35).
5. Remove all drives ("Removing the drive" on page 35).
6. If installed, remove the RCM module (on page 33).
7. Remove all power supplies ("Remove the power supply" on page 33).
8. Remove the chassis from the rack (on page 34).
9. Remove the access panel ("Remove the chassis access panel" on page 36).
10. Remove the HP Smart Storage Battery holder.

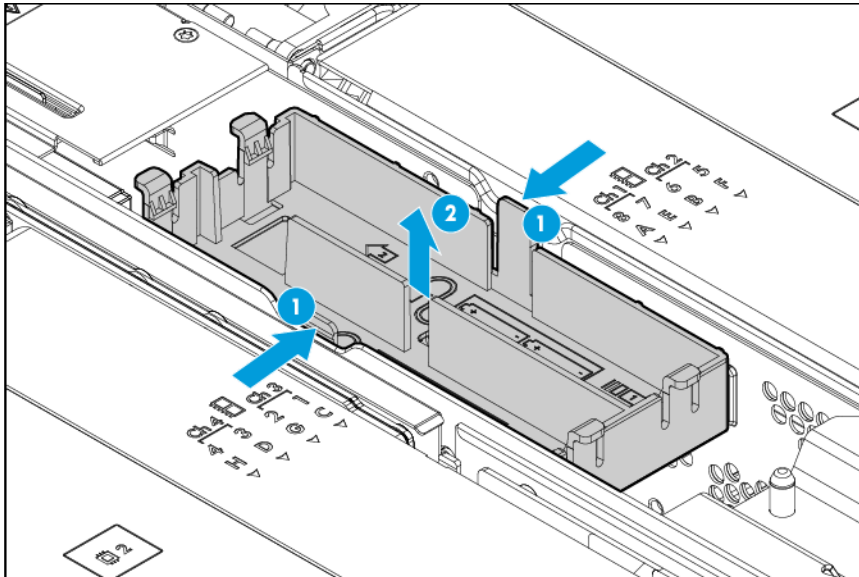

11. Route the cable through holder and install the HP Smart Storage Battery.

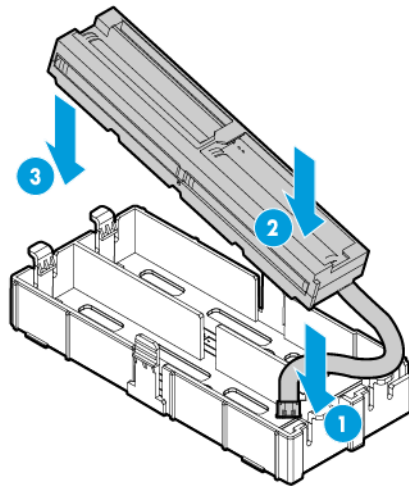

12. Connect the HP Smart Storage Battery cable to power distribution board.
13. Install the HP Smart Storage Battery holder into the chassis.

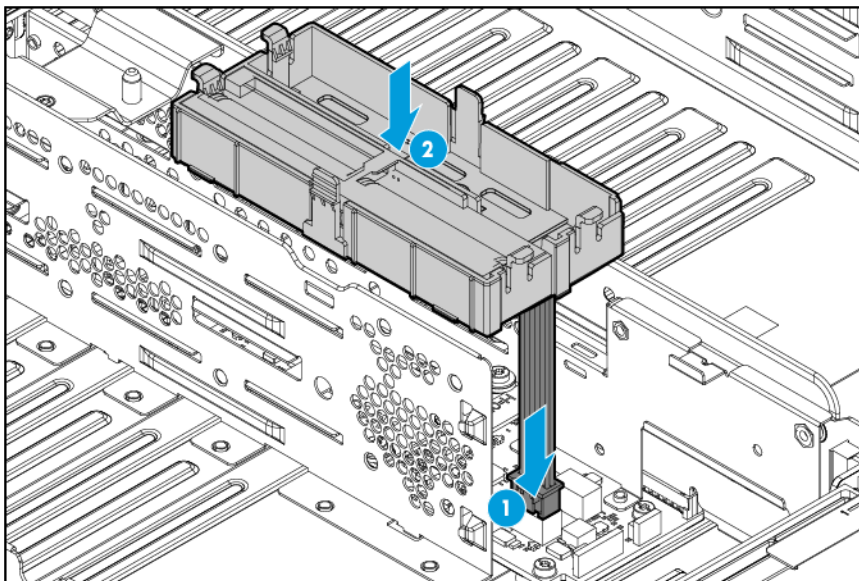

14. Install the access panel ("[Install the chassis access panel](#)" on page 37).
15. Install the chassis into the rack ("[Installing the chassis into the rack](#)" on page 59).
16. Install all nodes, drives and power supplies ("[Chassis component installation](#)" on page 60).
17. If removed, install the security bezel ("[Security bezel option](#)" on page 64).
18. If removed, install the RCM module ("[Rack control management \(RCM\) module](#)" on page 67).
19. Connect all peripheral cables to the nodes and chassis.
20. Power up the nodes (on page 31).

# Graphic card options

## Graphic card/coprocessor power setting switch

Before installing a graphic card/coprocessor option, set the graphic card/coprocessor power setting switch to the correct settings based on the power consumption of the graphic card/coprocessor. The switch is located on the 2U bayonet board.

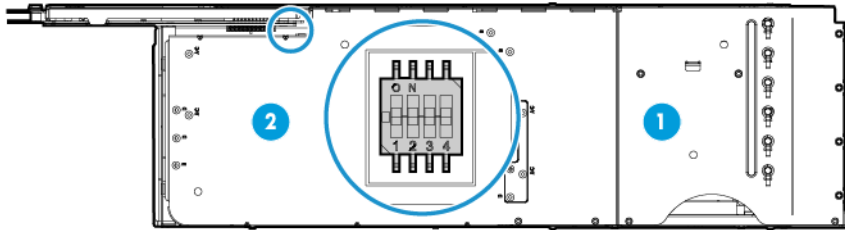

- Switches 1 and 2 correspond to graphic card 1/coprocessor 1
- Switches 3 and 4 correspond to graphic card 2/coprocessor 2

Item	Switch	150W	225W/ 235W	300W	No graphic card/ coprocessor installed (default)
1 - First graphic card/ coprocessor	1	OFF	ON	ON	OFF
	2	ON	OFF	ON	OFF
2 - Second graphic card/ coprocessor	3	OFF	ON	ON	OFF
	4	ON	OFF	ON	OFF

## Single graphic card/ coprocessor power cable option

This power cable is for use in the FlexibleLOM 2U node riser cage assembly only.

For more information about product features, specifications, options, configurations, and compatibility, see the product QuickSpecs on the HP website (<http://www.hp.com/go/qs>).

To install the component:

1. Power down the node (on page 31).
2. Disconnect all peripheral cables from the node.
3. Remove the server node from the chassis ("Remove the node from the chassis" on page 32).
4. Place the node on a flat, level surface.
5. Remove the FlexibleLOM 2U node riser cage assembly (on page 52).
6. Set the graphic card power setting switch to the correct settings based on the power consumption of the graphic card. ("Graphic card/coprocessor power setting switch" on page 101)  
For more information, see the documentation that ships with the graphic card option.
7. If installing a half-height graphic card, remove the middle PCI blank only.

8. If installing a full-height graphic card, remove the middle and top PCI blanks.

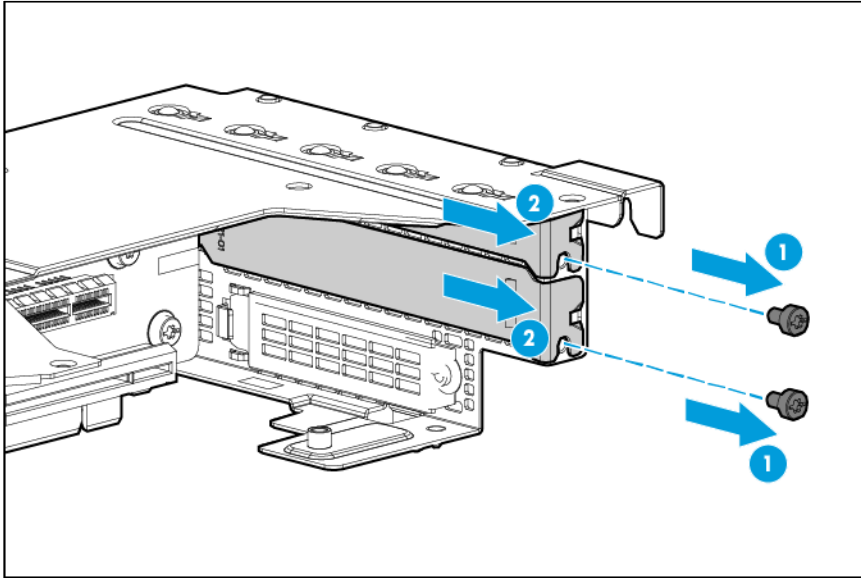

9. Connect the power cable to the connector on the riser board.

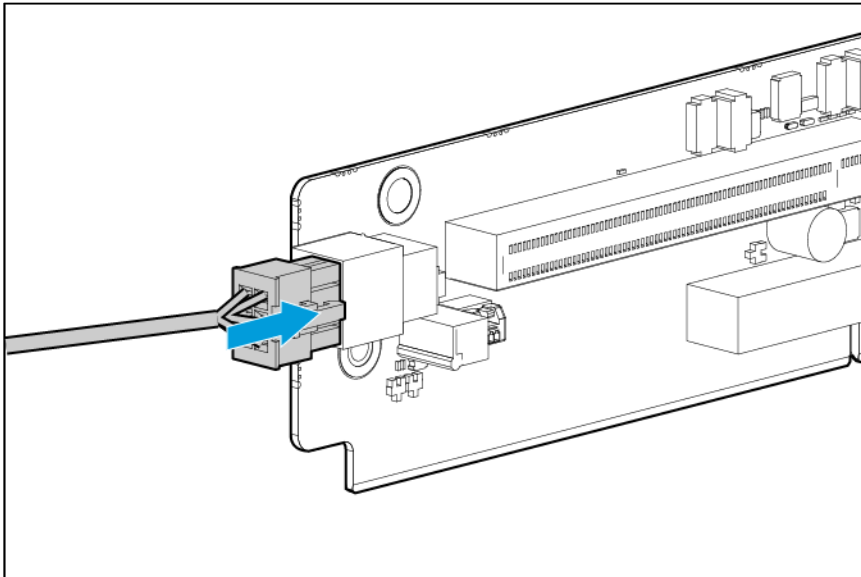

10. Install the graphic card into the PCI riser cage assembly.

11. If installing an NVIDIA Tesla K40 GPU, connect the 2-pin graphic card adapter cable to the graphic card and the riser board.

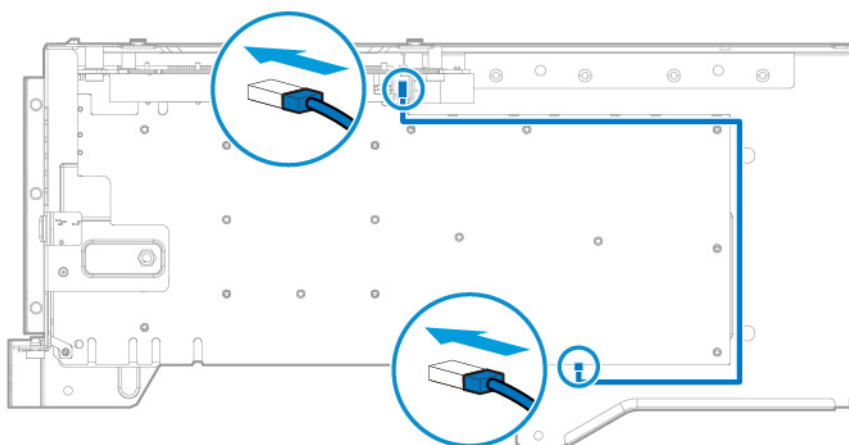

12. Connect the power cable to the graphic card.
13. Install the FlexibleLOM 2U node riser cage assembly and then secure it with five T-10 screws.
14. Connect the power cable to the bayonet board.

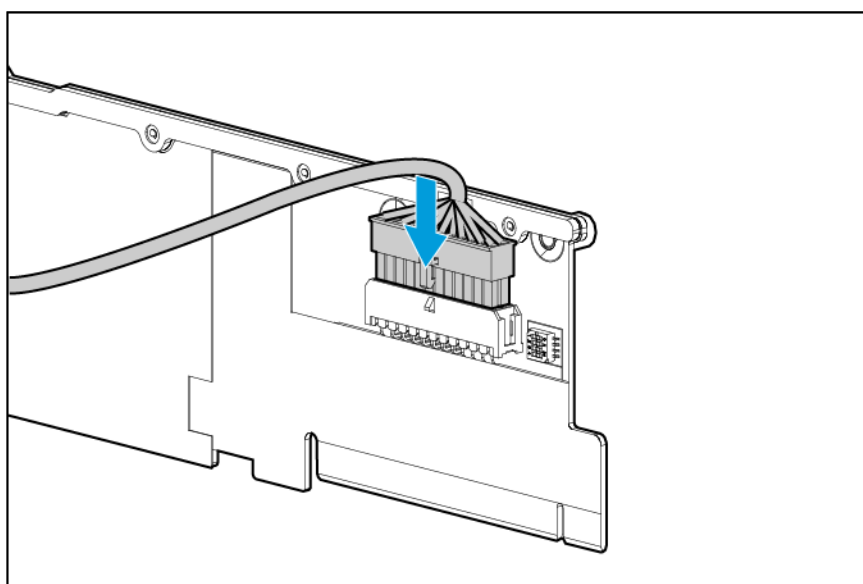

15. Install the node into the chassis ("[Installing a node into the chassis](#)" on page 60).
16. Connect all peripheral cables to the nodes.
17. Power up the node ("[Power up the nodes](#)" on page 31).

## Dual graphic card/ coprocessor power cable option

This power cable is for use in the three-slot PCI riser cage assembly and three-slot GPU-direct PCI riser cage assembly.

For more information about product features, specifications, options, configurations, and compatibility, see the product QuickSpecs on the HP website (<http://www.hp.com/go/qs>).

To install the component:

1. Power down the node (on page 31).
2. Disconnect all peripheral cables from the node.
3. Remove the server node from the chassis ("Remove the node from the chassis" on page 32).
4. Place the node on a flat, level surface.
5. Remove the three-slot PCI riser cage assembly ("Three-slot PCI riser cage assemblies" on page 53).
6. Set the graphic card power setting switch to the correct settings based on the power consumption of the graphic card.

For more information, see the documentation that ships with the graphic card option.

7. Remove the riser cage bracket.

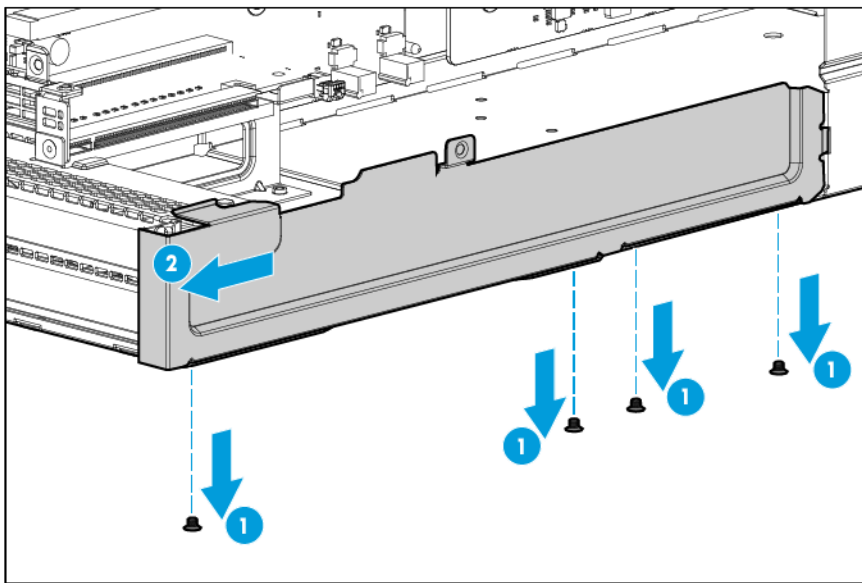

8. If installing a half-height graphic card, remove the middle PCI blank only.



9. If installing a full-height graphic card, remove the middle and top PCI blanks.

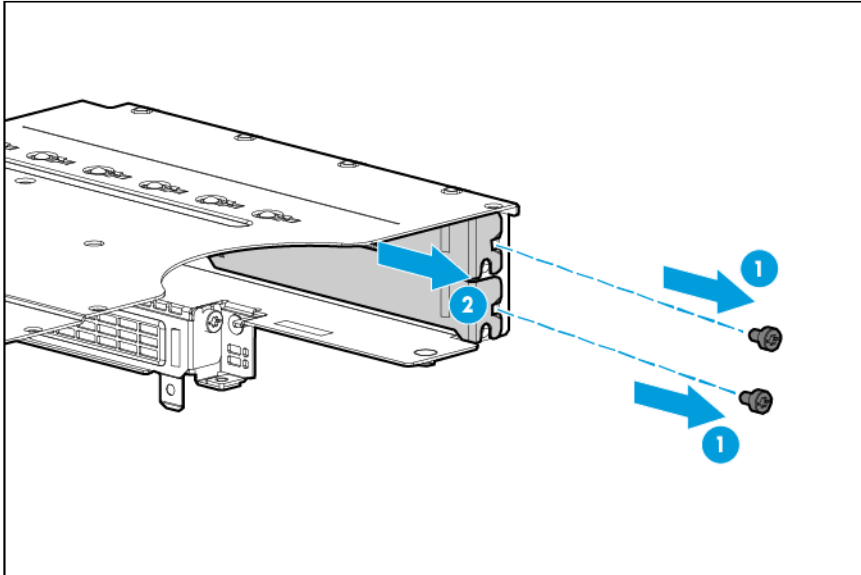

10. Turn the riser cage assembly over and lay it along the right side of the node.
11. Connect the power cable to the first graphic card.
12. Install the first graphic card in the front of the riser cage assembly.
13. Install the second graphic card into the rear of the riser cage assembly.
14. Connect the power cable to the second graphic card.
15. If installing two NVIDIA Tesla K40 GPUs, connect the 2-pin graphic card adapter cables to the graphic cards and the riser board.

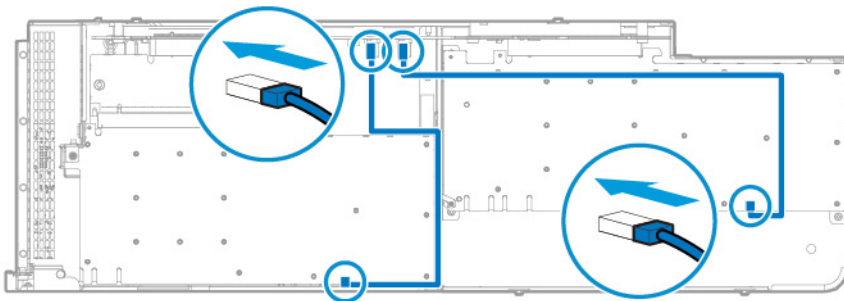

16. Connect the power cable to the bayonet board.

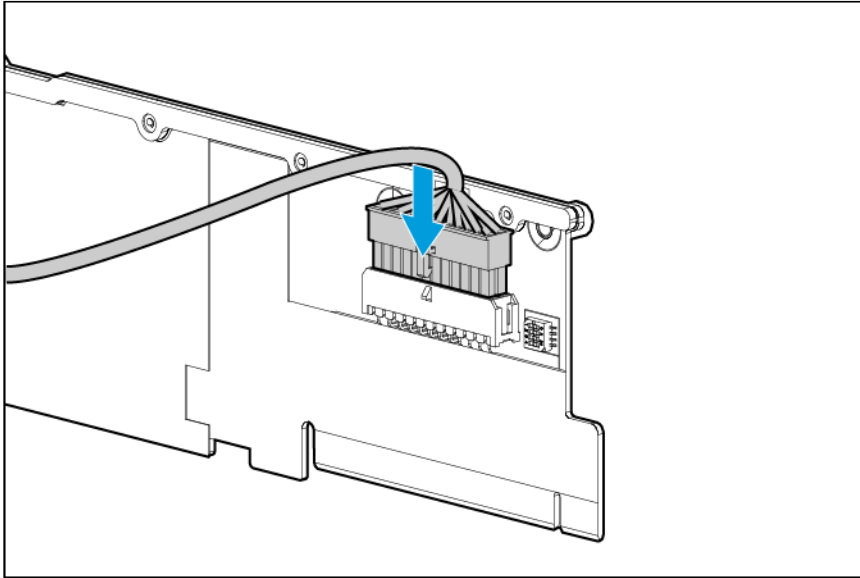

17. Install the riser cage blank.

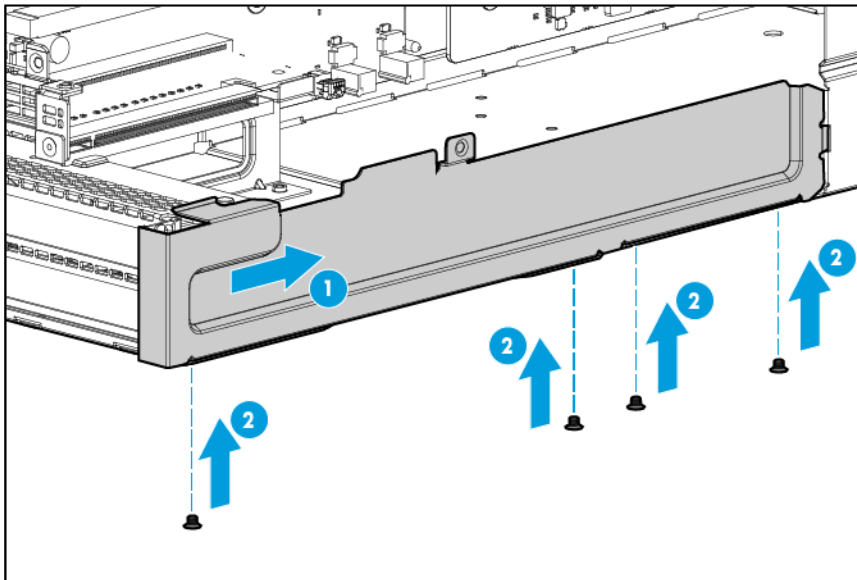

18. Install the three-slot riser cage assembly and then secure it with six T-10 screws ("[Three-slot PCI riser cage assembly options](#)" on page 93).
19. Install the node into the chassis ("[Installing a node into the chassis](#)" on page 60).
20. Connect all peripheral cables to the nodes.
21. Power up the node ("[Power up the nodes](#)" on page 31).

## NVIDIA Tesla K40 12GB Module Enablement Kit

The enablement kit is for the following configurations:

- Installing one K40 12GB module in the FlexibleLOM 2U node PCI riser cage assembly (on page [107](#))

- Installing two K40 12GB modules in a three-slot PCI riser cage assembly or three-slot GPU-direct PCI riser cage assembly (on page 110)

## Installing one K40 12GB module in the FlexibleLOM 2U node PCI riser cage assembly

For more information about product features, specifications, options, configurations, and compatibility, see the product QuickSpecs on the HP website (<http://www.hp.com/go/qs>).

To install the component:

1. Power down the node (on page 31).
2. Disconnect all peripheral cables from the node.
3. Remove the server node from the chassis ("Remove the node from the chassis" on page 32).
4. Place the node on a flat, level surface.
5. Remove the FlexibleLOM 2U node PCI riser cage assembly ("FlexibleLOM 2U node riser cage assembly" on page 52).
6. Set the graphic card/coprocessor power setting switch to the correct settings (225W/235W) based on the power consumption of the graphic card/coprocessor ("Graphic card/coprocessor power setting switch" on page 101).

For more information, see the documentation that ships with the graphic card/coprocessor option.

7. Remove the two top PCI blanks from the riser cage assembly.

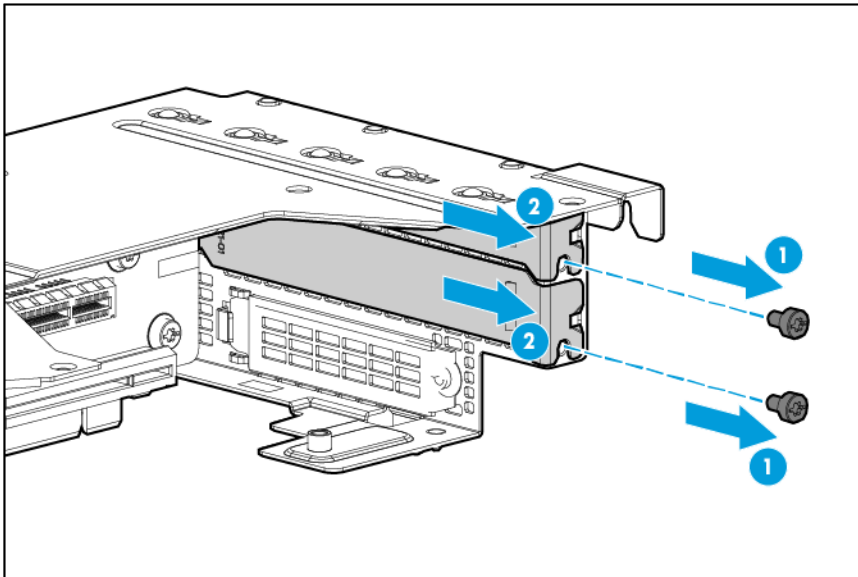

8. Connect the single graphic card/coprocessor power cable to the connector on the riser board.

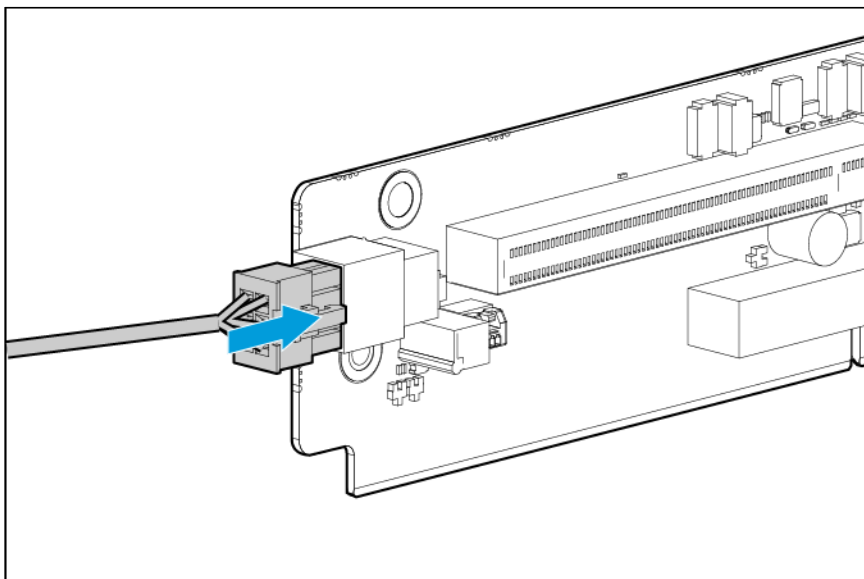

9. Install the graphic card into the PCI riser cage assembly.

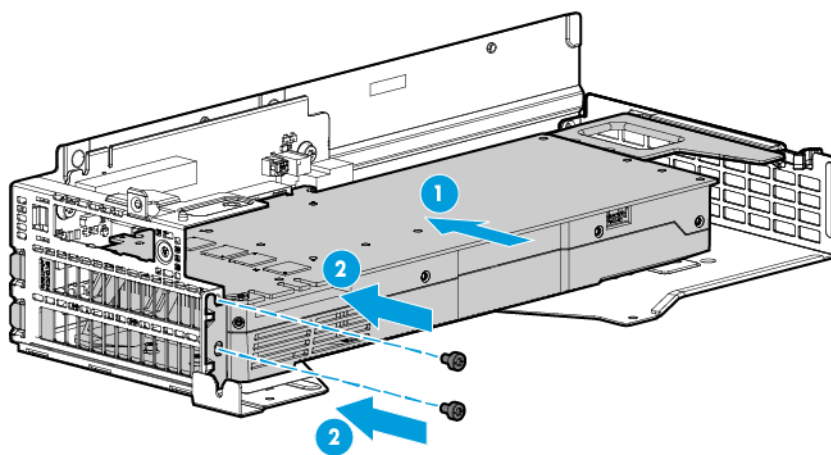

10. Connect the power cable to the graphic card.

11. Connect the 2-pin graphic card adapter cable.

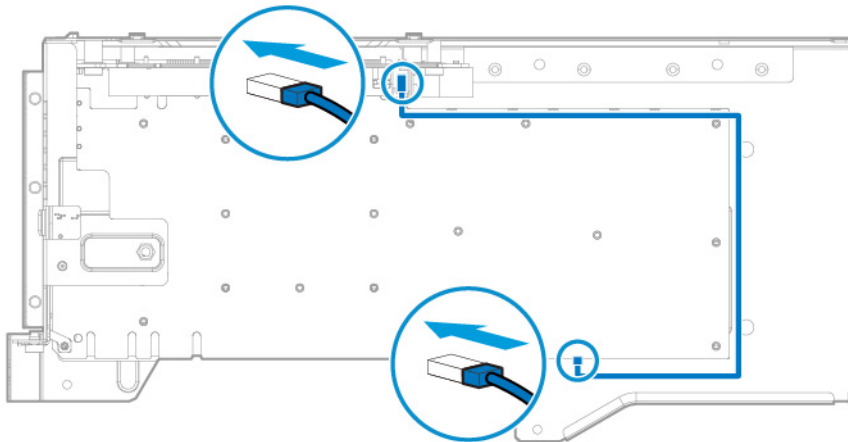

12. Install the FlexibleLOM 2U node riser cage assembly and then secure it with five T-10 screws.

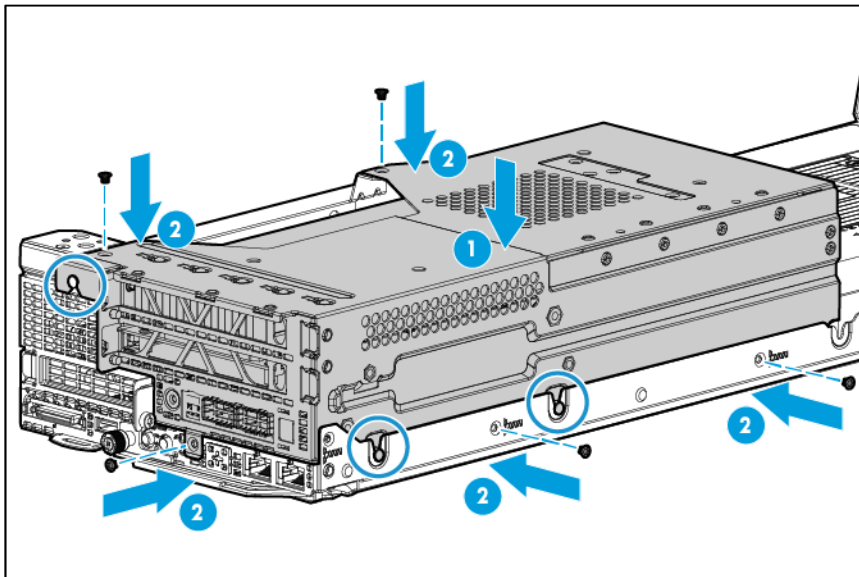

13. Connect the power cable to the bayonet board.

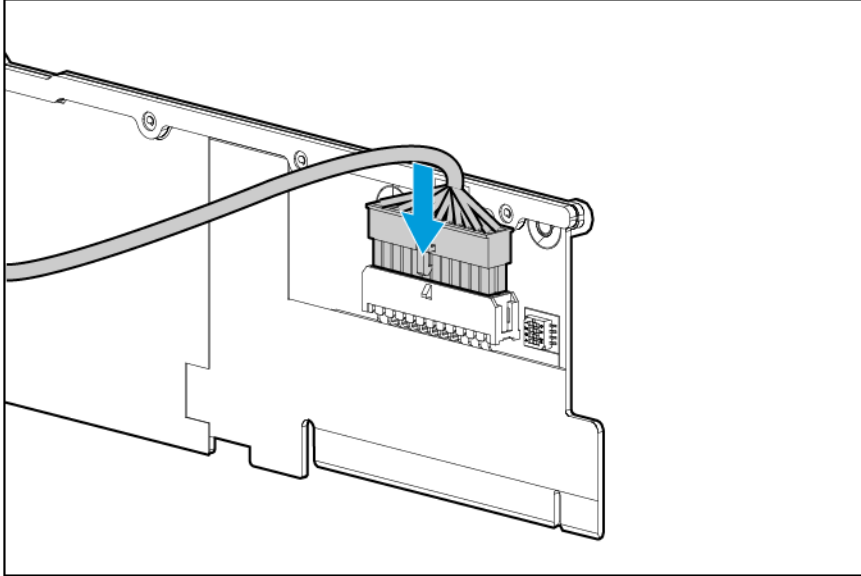

14. Install the node into the chassis ("Installing a node into the chassis" on page 60).
15. Connect all peripheral cables to the nodes.
16. Power up the node ("Power up the nodes" on page 31).

## Installing two K40 12GB modules in a three-slot PCI riser cage assembly or three-slot GPU-direct PCI riser cage assembly

For more information about product features, specifications, options, configurations, and compatibility, see the product QuickSpecs on the HP website (<http://www.hp.com/go/qs>).

To install the component:

1. Power down the node (on page 31).
2. Disconnect all peripheral cables from the node.
3. Remove the server node from the chassis ("Remove the node from the chassis" on page 32).
4. Place the node on a flat, level surface.
5. Remove the three-slot PCI riser cage assembly ("Three-slot PCI riser cage assemblies" on page 53).
6. Set the graphic card/coprocessor power setting switch to the correct settings (225W/235W) based on the power consumption of the graphic card/coprocessor.

For more information, see the documentation that ships with the graphic card/coprocessor option.

7. Remove the riser cage bracket.

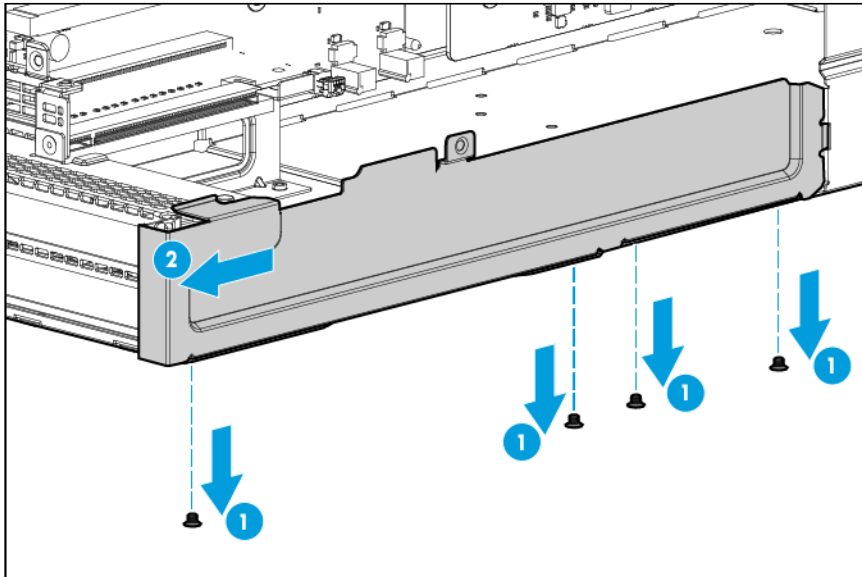

8. Remove the two top PCI blanks from the riser cage assembly.

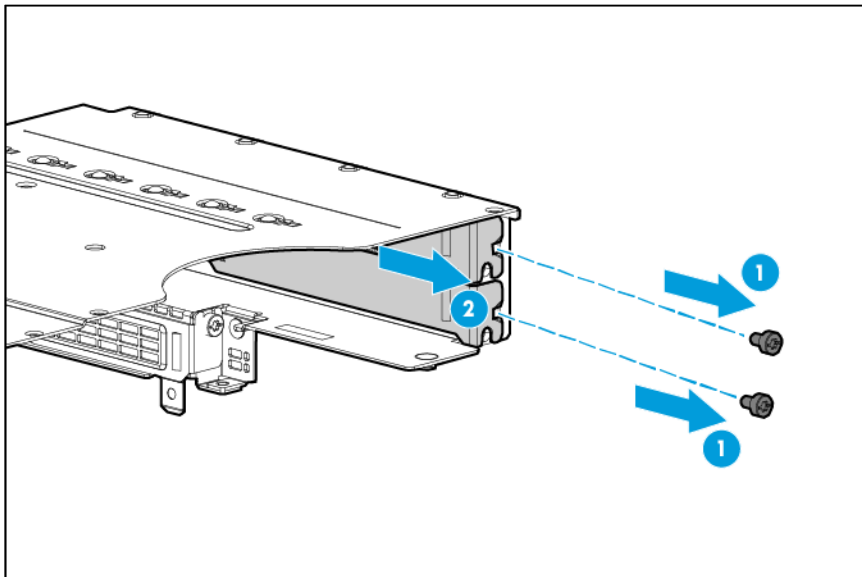

9. Turn the riser cage assembly over and lay it along the right side of the node.
10. Remove the existing rear support brackets from the first and second graphic cards.

11. Install the rear support bracket onto the first graphic card.

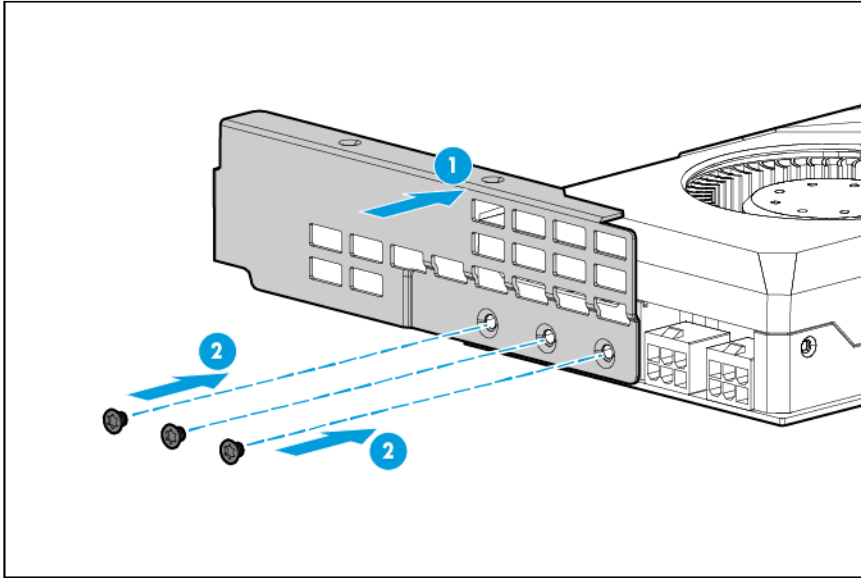

12. Install the first graphic card into the front of the PCI riser cage assembly.

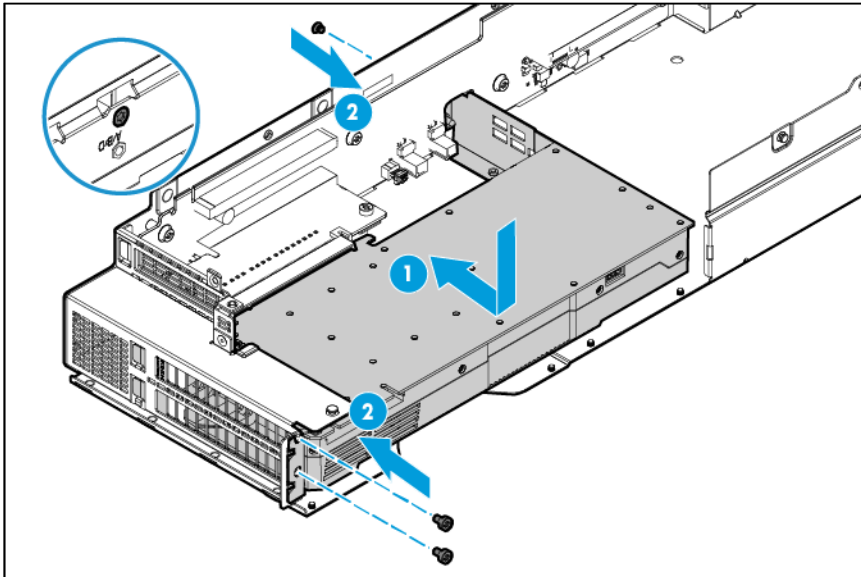

13. Connect the power cable to the first graphic card.
14. Remove the existing front I/O bracket from the second graphic card.
15. Install the rear and front support brackets onto the second graphic card:
  - a. Secure the rear support bracket with three T-10 screws.



- b. Secure the front support bracket with three M2.5 screws.

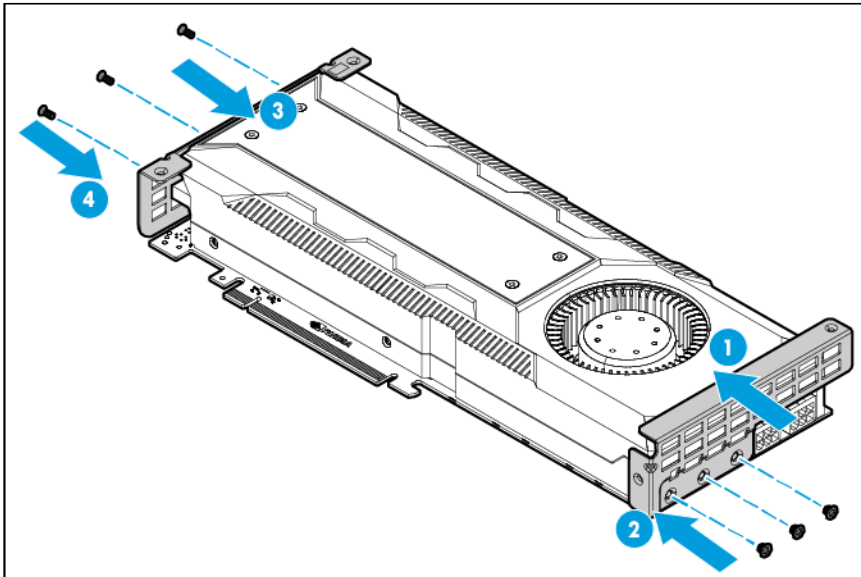

- 16. Install the second graphic card.

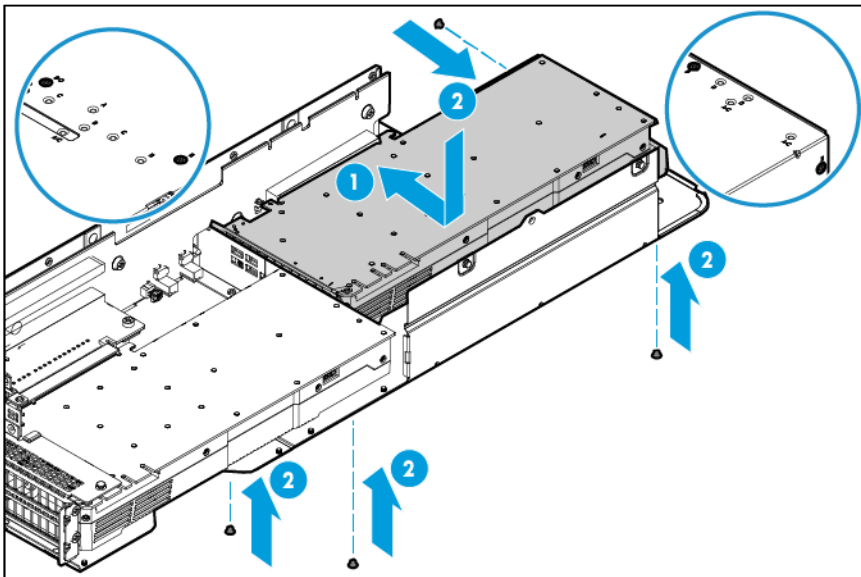

- 17. Connect the dual graphic card/coprocessor power cable to the graphic cards.
- 18. Connect the 2-pin graphic card adapter cables to the graphic cards and the riser board.

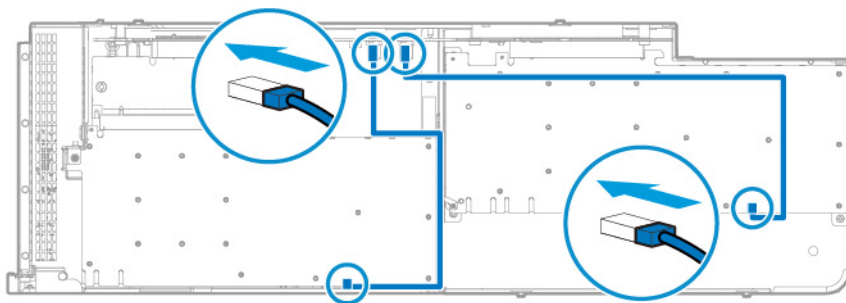

19. Install the riser cage bracket.

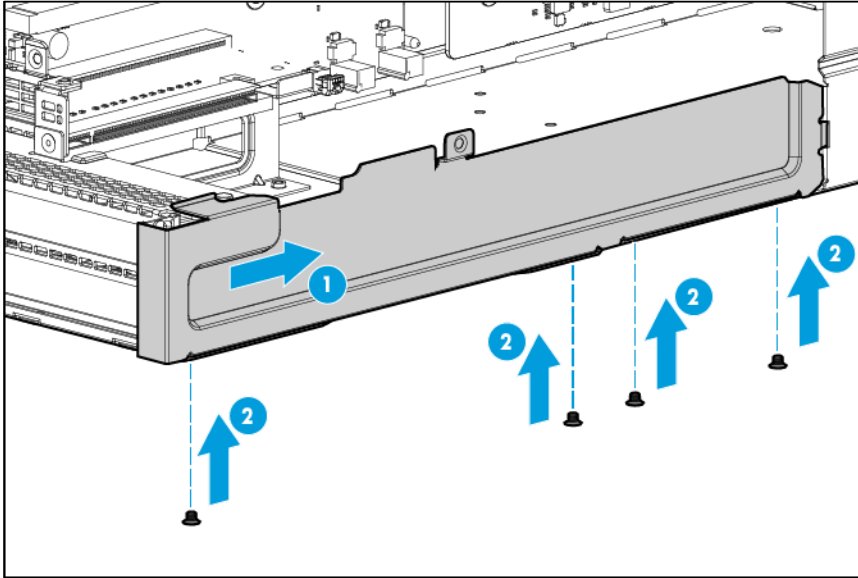

20. Connect the power cable to the bayonet board.

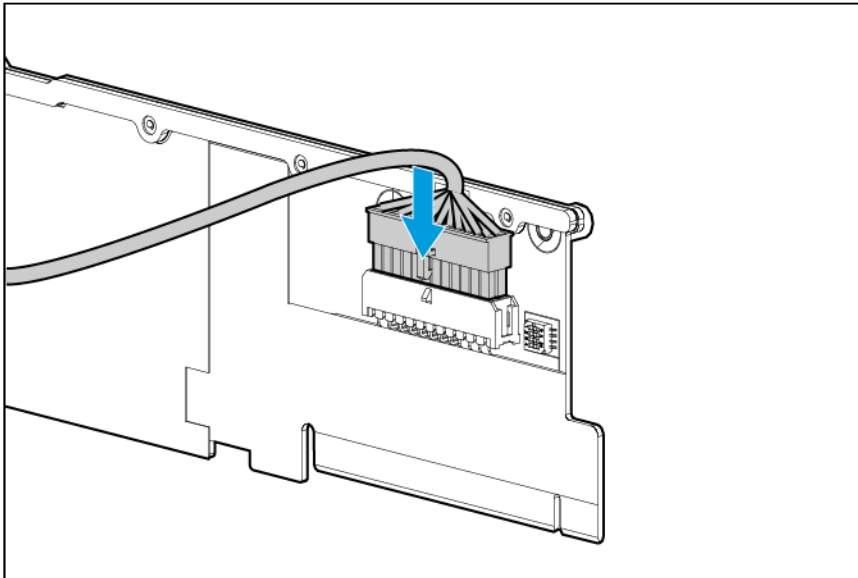

21. Install the three-slot riser cage assembly and then secure it with six T-10 screws ("[Three-slot PCI riser cage assembly options](#)" on page 93).
22. Install the node into the chassis ("[Installing a node into the chassis](#)" on page 60).
23. Connect all peripheral cables to the nodes.
24. Power up the node ("[Power up the nodes](#)" on page 31).

## Intel Coprocessor Enablement Kit

The enablement kit is for the following configurations:

- Installing one Intel coprocessor in the FlexibleLOM 2U node PCI riser cage assembly (on page 115)

- Installing two Intel coprocessors in a three-slot PCI riser cage assembly or a three-slot GPU-direct PCI riser cage assembly ("Installing two Intel coprocessors in a three-slot PCI riser cage assembly" on page 117)

## Installing one Intel coprocessor in the FlexibleLOM 2U node PCI riser cage assembly

For more information about product features, specifications, options, configurations, and compatibility, see the product QuickSpecs on the HP website (<http://www.hp.com/go/qs>).

To install the component:

1. Power down the node (on page 31).
2. Disconnect all peripheral cables from the node.
3. Remove the server node from the chassis ("Remove the node from the chassis" on page 32).
4. Place the node on a flat, level surface.
5. Remove the FlexibleLOM 2U node PCI riser cage assembly ("FlexibleLOM 2U node riser cage assembly" on page 52).
6. Set the graphic card/coprocessor power setting switch to the correct settings based on the power consumption of the coprocessor.

For more information, see the documentation that ships with the coprocessor option.

7. Remove the two top PCI blanks from the riser cage assembly.

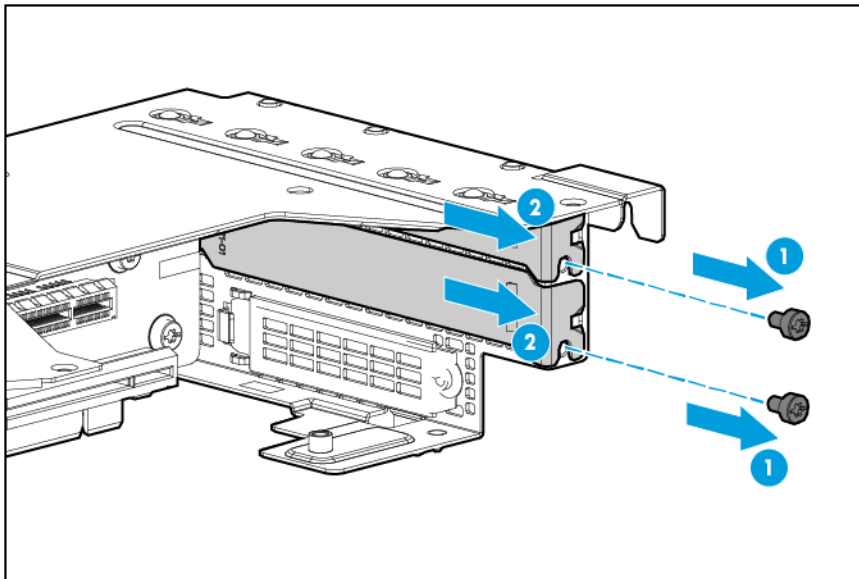

8. Connect the single graphic card power cable to the connector on the riser board.

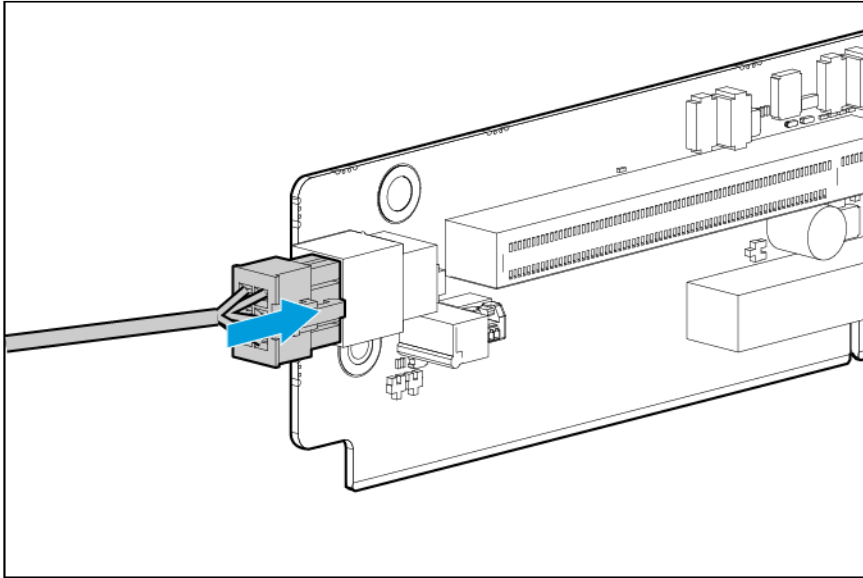

9. Connect the power cable to the coprocessor.
10. Install the coprocessor into the PCI riser cage assembly.

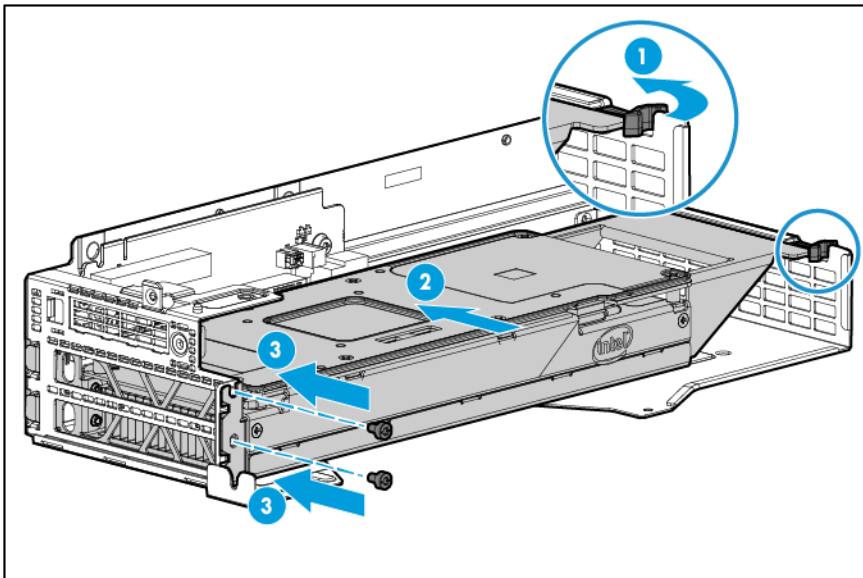

11. Install the FlexibleLOM 2U node riser cage assembly and then secure it with five T-10 screws ("FlexibleLOM 2U node riser cage assembly option" on page 92).

12. Connect the power cable to the bayonet board.

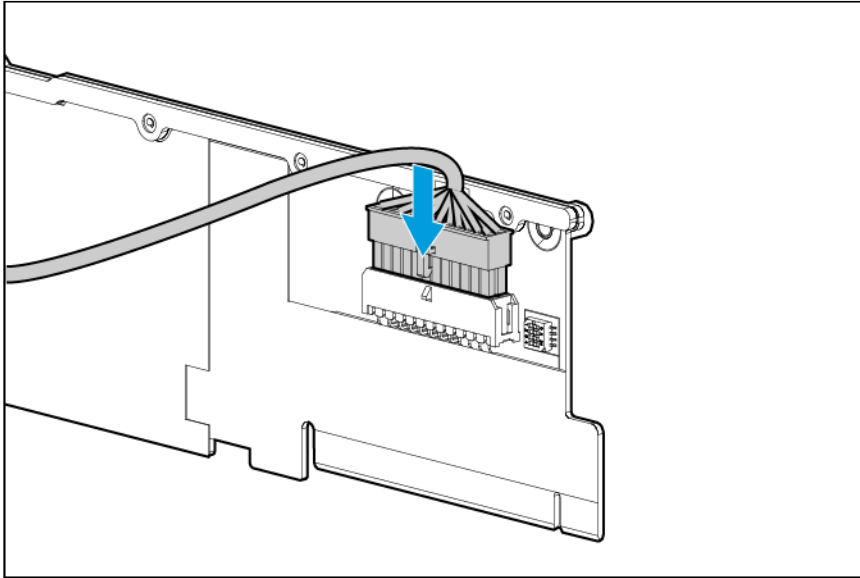

13. Install the node into the chassis ("Installing a node into the chassis" on page 60).
14. Connect all peripheral cables to the nodes.
15. Power up the node ("Power up the nodes" on page 31).

## Installing two Intel coprocessors in a three-slot PCI riser cage assembly

For more information about product features, specifications, options, configurations, and compatibility, see the product QuickSpecs on the HP website (<http://www.hp.com/go/qs>).

To install the component:

1. Power down the node (on page 31).
2. Disconnect all peripheral cables from the node.
3. Remove the server node from the chassis ("Remove the node from the chassis" on page 32).
4. Place the node on a flat, level surface.
5. Remove the three-slot PCI riser cage assembly ("Three-slot PCI riser cage assemblies" on page 53).
6. Set the graphic card/coprocessor power setting switch to the correct settings based on the power consumption of the coprocessor.

For more information, see the documentation that ships with the graphic card option.

7. Remove the riser cage bracket.

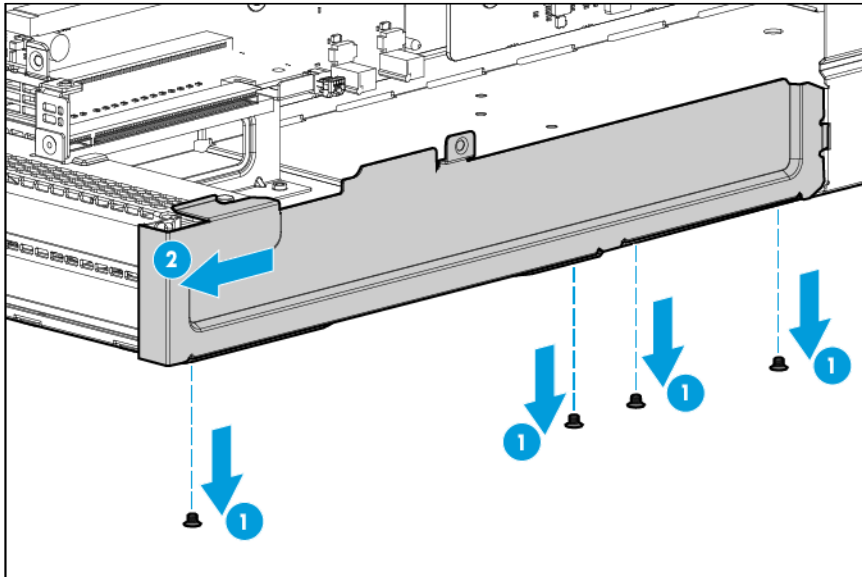

8. Remove the two top PCI blanks from the riser cage assembly.

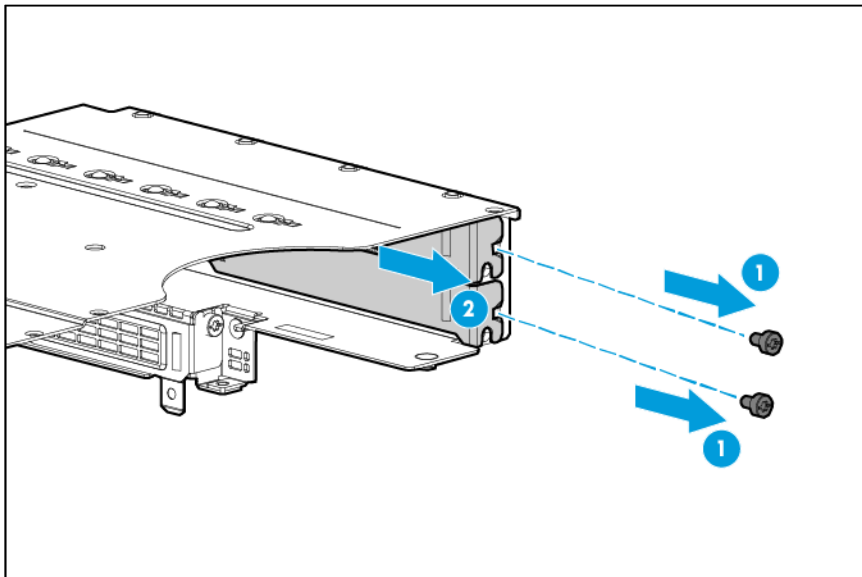

9. Turn the riser cage assembly over and lay it along the right side of the node.
10. Remove the existing rear support brackets from the first and second coprocessors.

11. Install one support bracket onto the rear of the first coprocessor.

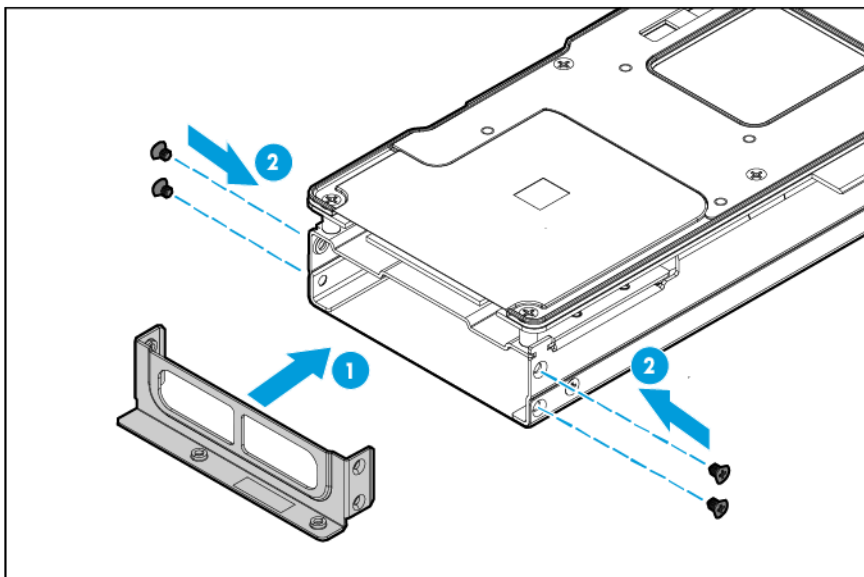

12. Install the first coprocessor into the front of the PCI riser cage assembly.

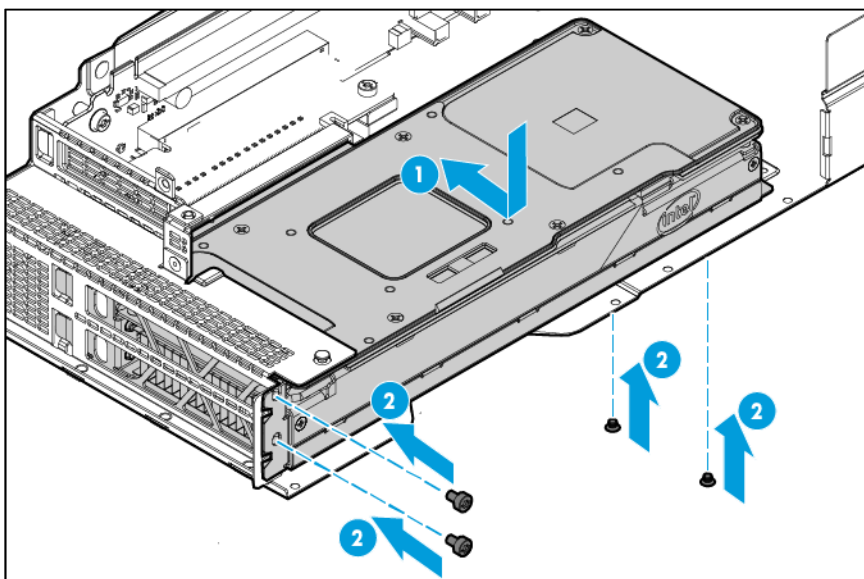

13. Connect the dual graphic card/coprocessor power cable to the first coprocessor.

14. Remove the existing front I/O bracket from the second coprocessor.

15. Install two support brackets onto the second coprocessor.

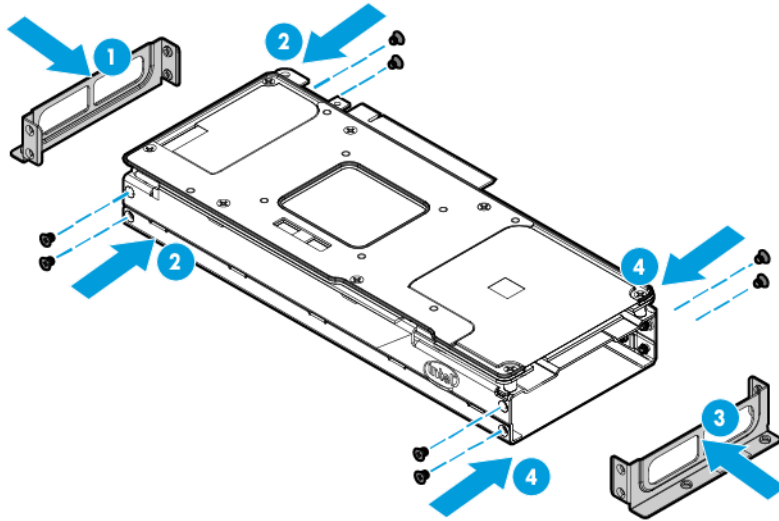

16. Install the second coprocessor into the PCI riser cage assembly.

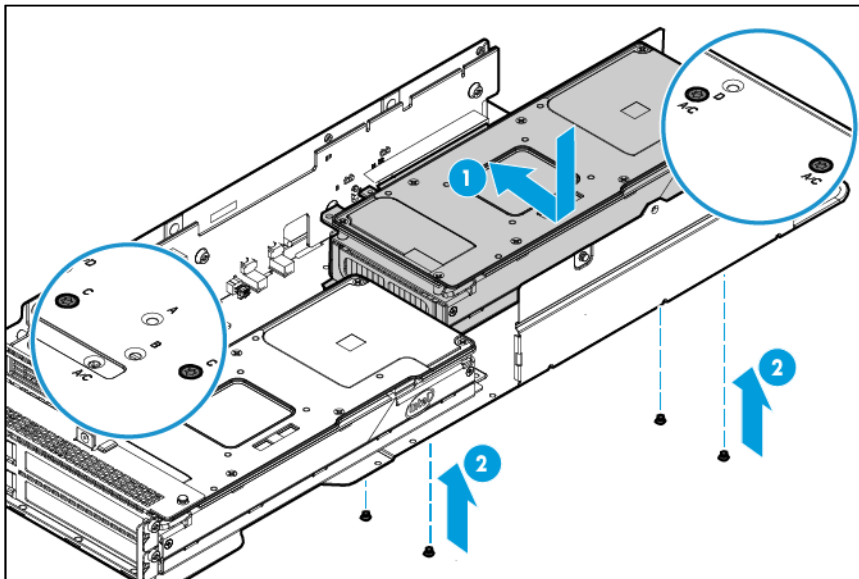

17. Connect the dual graphic card power cable to the second coprocessor.



18. Install the riser cage bracket.

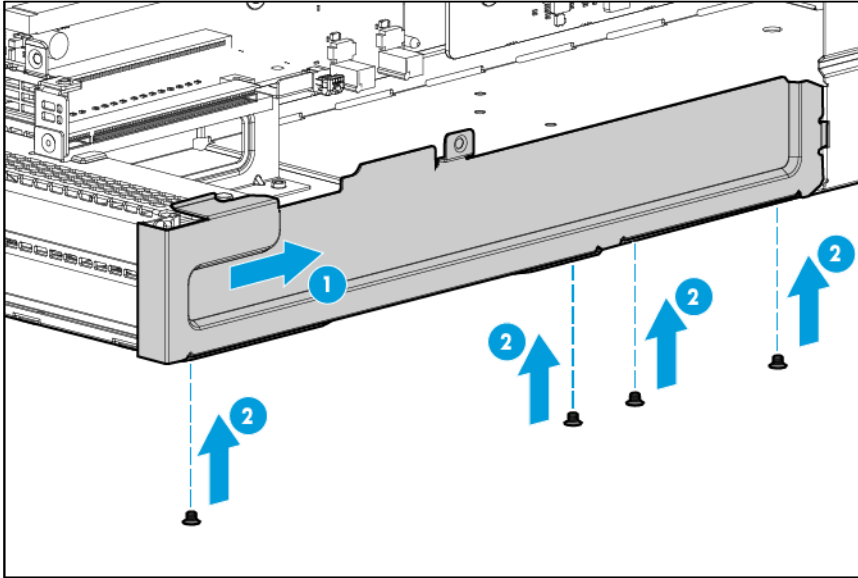

19. Connect the power cable to the bayonet board.

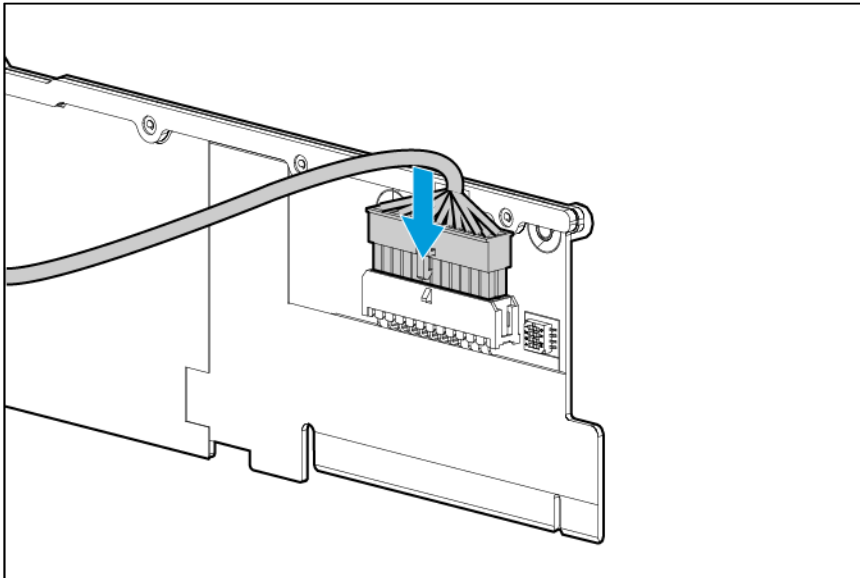

20. Install the three-slot riser cage assembly and then secure it with six T-10 screws ("[Three-slot PCI riser cage assembly options](#)" on page 93).
21. Install the node into the chassis ("[Installing a node into the chassis](#)" on page 60).
22. Connect all peripheral cables to the nodes.
23. Power up the node ("[Power up the nodes](#)" on page 31).

## M.2 SATA SSD enablement board

The M.2 SATA SSD enablement board can only be installed on the single-slot left PCI riser cage assembly and the single-slot 2U node PCI riser cage assembly.

For more information about product features, specifications, options, configurations, and compatibility, see the product QuickSpecs on the HP website (<http://www.hp.com/go/qs>).

To install the component:

1. Power down the node (on page 31).
2. Disconnect all peripheral cables from the node.
3. Remove the node from the chassis (on page 32).
4. Place the node on a flat, level surface.
5. Do one of the following:
  - a. Remove the single-slot left PCI riser cage assembly (on page 48).
  - b. Remove the single-slot 2U node PCI riser cage assembly (on page 51).
6. If installed, remove the storage controller.
7. Install the enablement board on the PCI riser cage assembly, and then secure it with a T-15 screw.
  - o Single-slot left PCI riser cage assembly

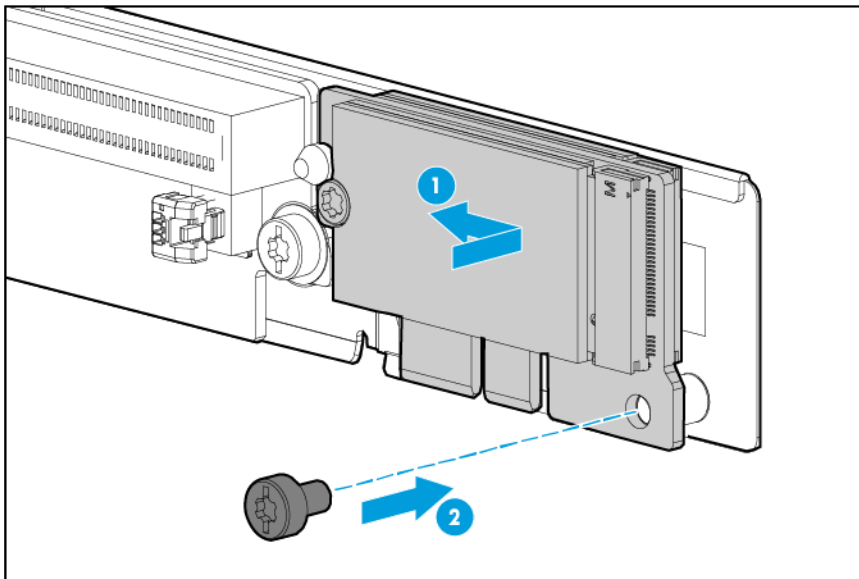

- Single-slot 2U node PCI riser cage assembly

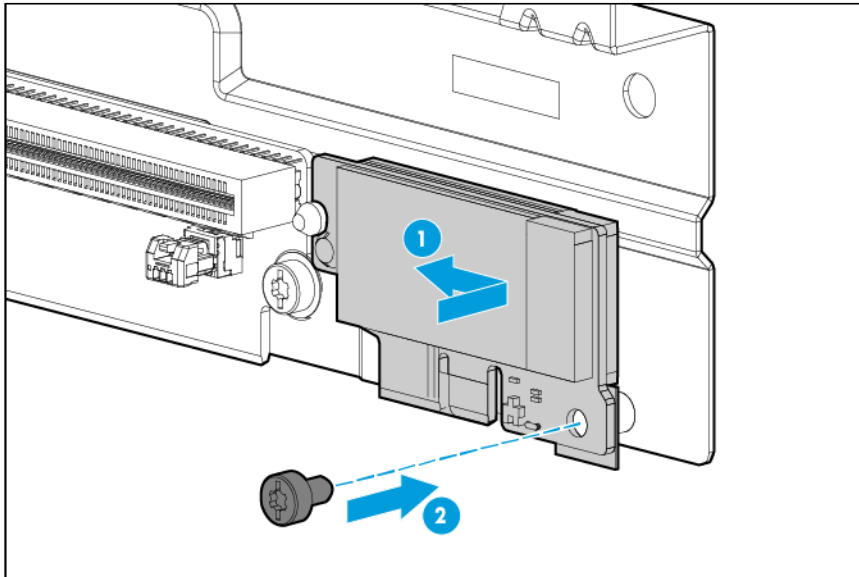

8. If removed, install the storage controller.
9. Install any removed PCI riser cage assemblies ("PCI riser cage assembly options" on page 84).
10. Install the node into the chassis ("Installing a node into the chassis" on page 60).
11. Connect all peripheral cables to the nodes.
12. Power up the node ("Power up the nodes" on page 31).

## Processor and heatsink

For more information about product features, specifications, options, configurations, and compatibility, see the product QuickSpecs on the HP website (<http://www.hp.com/go/qs>).

To install the component:

1. Power down the node (on page 31).
2. Disconnect all peripheral cables from the node.
3. Remove the server node from the chassis ("Remove the node from the chassis" on page 32).
4. Place the node on a flat, level surface.

---

**⚠ WARNING:** To reduce the risk of personal injury from hot surfaces, allow the drives and the internal system components to cool before touching them.

---

**⚠ CAUTION:** To avoid damage to the processor and system board, only authorized personnel should attempt to replace or install the processor in this node.

---

**⚠ CAUTION:** To prevent possible node malfunction and damage to the equipment, multiprocessor configurations must contain processors with the same part number.

---

**⚠ CAUTION:** The heatsink thermal interface media is not reusable and must be replaced if the heatsink is removed from the processor after it has been installed.

---



**IMPORTANT:** Processor socket 1 must be populated at all times or the node does not function.

5. If installed in a 2U node, remove the FlexibleLOM 2U node riser cage assembly ("FlexibleLOM 2U node riser cage assembly" on page 52).
6. If installed in a 2U node, remove the three-slot PCI riser cage assembly ("Three-slot PCI riser cage assemblies" on page 53).
7. Remove the air baffle (on page 41).
8. Open each of the processor locking levers in the order indicated in the following illustration, and then open the processor retaining bracket.

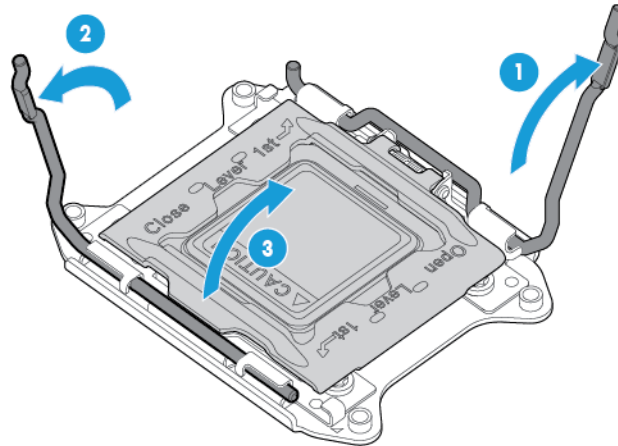

9. Remove the clear processor socket cover. Retain the processor socket cover for future use.

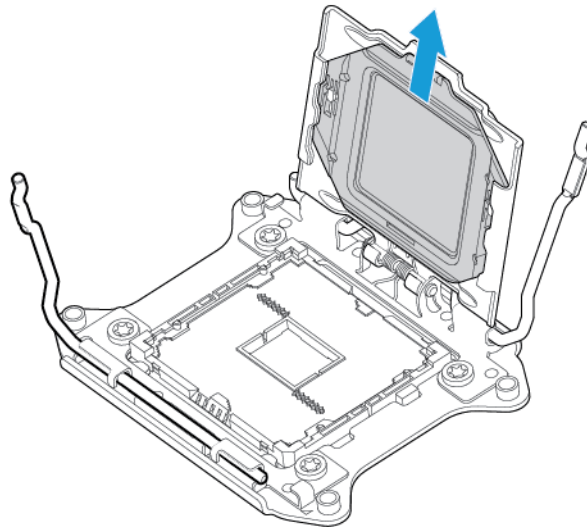

**CAUTION:** THE PINS ON THE SYSTEM BOARD ARE VERY FRAGILE AND EASILY DAMAGED. To avoid damage to the system board, do not touch the processor or the processor socket contacts.

10. Install the processor. Verify that the processor is fully seated in the processor retaining bracket by visually inspecting the processor installation guides on either side of the processor. **THE PINS ON THE SYSTEM BOARD ARE VERY FRAGILE AND EASILY DAMAGED.**

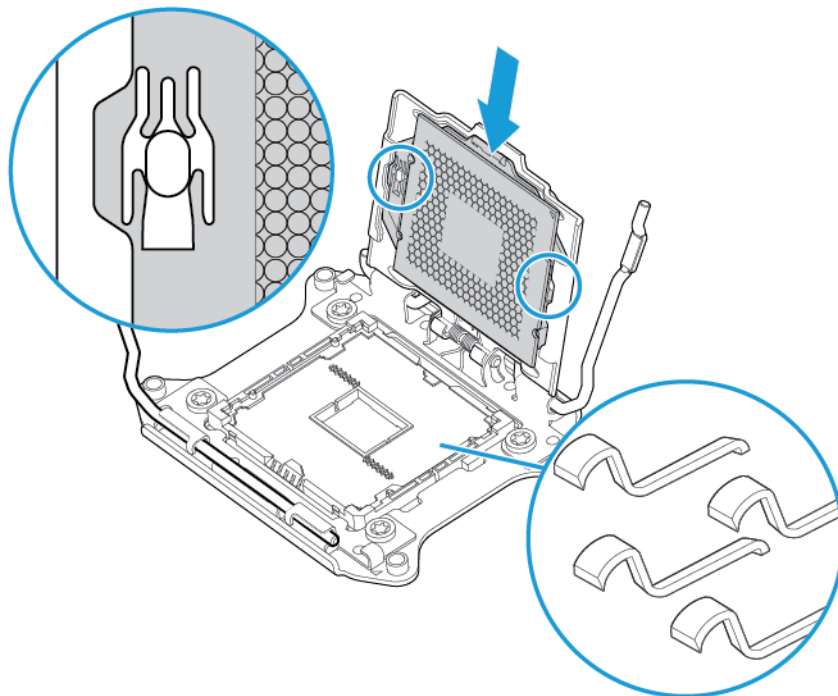

11. Close the processor retaining bracket. When the processor is installed properly inside the processor retaining bracket, the processor retaining bracket clears the flange on the front of the socket.

- 
- △ **CAUTION:** Do not press down on the processor. Pressing down on the processor may cause damage to the processor socket and the system board. Press only in the area indicated on the processor retaining bracket.
- 
- △ **CAUTION:** Close and hold down the processor cover socket while closing the processor locking levers. The levers should close without resistance. Forcing the levers closed can damage the processor and socket, requiring system board replacement.
-

12. Press and hold the processor retaining bracket in place, and then close each processor locking lever. Press only in the area indicated on the processor retaining bracket.

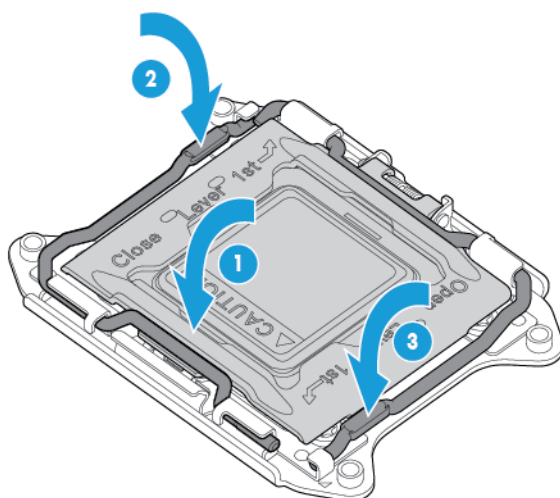

---

**CAUTION:** Always use a new heatsink when replacing processors. Failure to use new components can cause damage to the processor.

---

13. Remove the thermal interface protective cover from the heatsink.

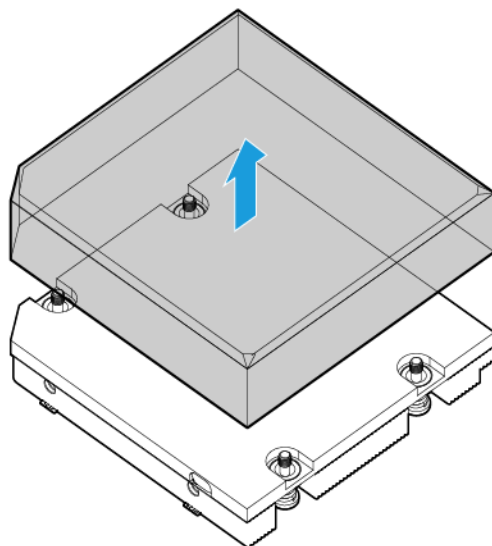

---

**CAUTION:** Heatsink retaining screws should be tightened or loosened in diagonally opposite pairs (in an "X" pattern). Do not overtighten the screws as this can damage the board, connectors, or screws. Use the wrench supplied with the system to reduce the possibility of overtightening the screws.

---

14. Install the heatsink:
  - a. Position the heatsink on the processor backplate.
  - b. Tighten one pair of diagonally opposite screws halfway, and then tighten the other pair of screws.

- c. Finish the installation by completely tightening the screws in the same sequence.

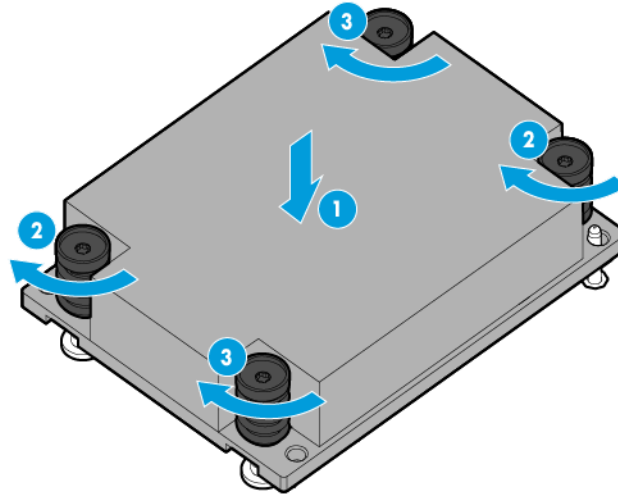

15. Install the air baffle (on page 42).
16. Install any removed PCI riser cage assemblies ("PCI riser cage assembly options" on page 84).
17. Install the node into the chassis ("Installing a node into the chassis" on page 60).
18. Connect all peripheral cables to the nodes.
19. Power up the node ("Power up the nodes" on page 31).

## Dedicated iLO management port module option

For more information about product features, specifications, options, configurations, and compatibility, see the product QuickSpecs on the HP website (<http://www.hp.com/go/qs>).

To install the component:

1. Power down the node (on page 31).
2. Disconnect all peripheral cables from the node.
3. Remove the server node from the chassis ("Remove the node from the chassis" on page 32).
4. Place the node on a flat, level surface.
5. Remove any installed PCI riser cage assemblies ("Remove the PCI riser cage assembly" on page 48).
6. Remove all rear I/O blanks:
  - o Remove the 1U left rear I/O blank (on page 38).
  - o Remove the 1U right rear I/O blank (on page 39).
  - o Remove the 2U rear I/O blank (on page 40).
7. Remove the knockout.

- a. Insert a flat screwdriver into the knockout.
- b. Twist and pull to remove the knockout from the node.

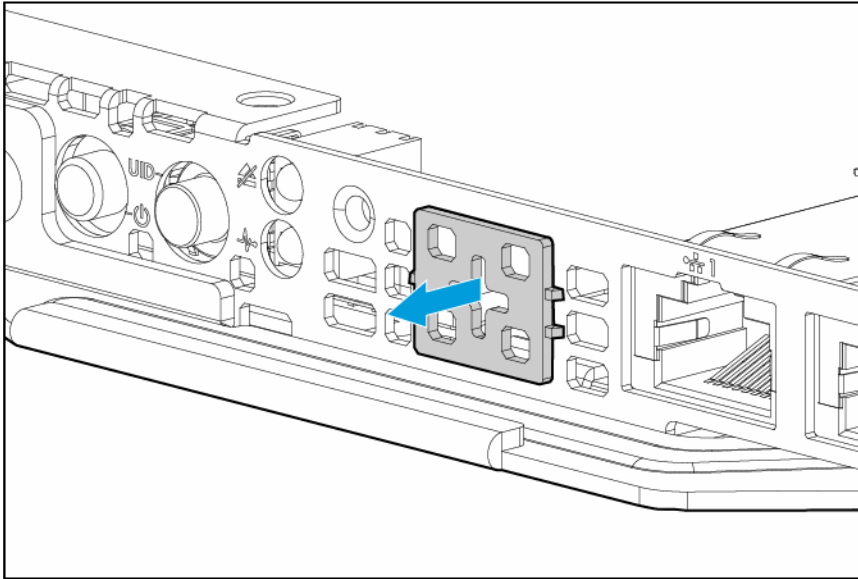

8. Install the dedicated iLO management port card into the node.

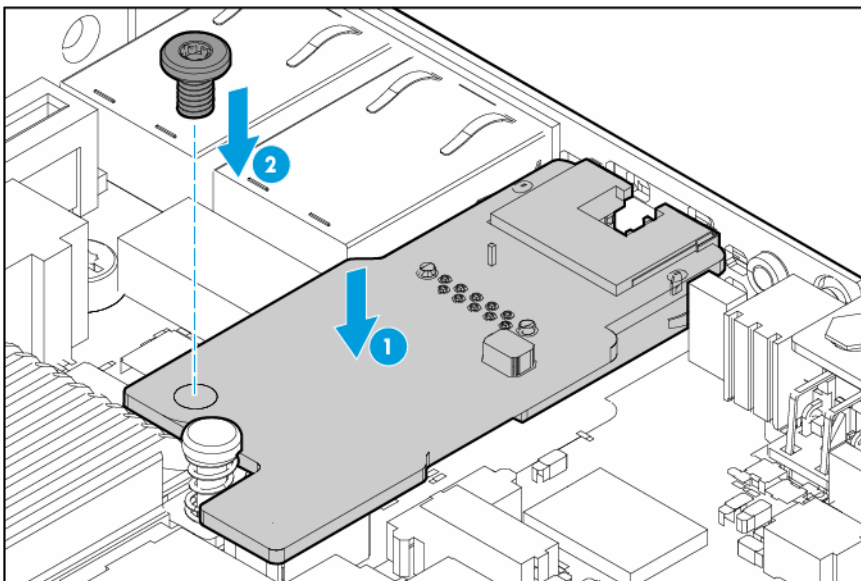

9. If removed, install all rear I/O blanks:
  - o Install the 1U left rear I/O blank (on page 38)
  - o Install the 1U right rear I/O blank (on page 40)
  - o Install the 2U rear I/O blank ("Install the 2U node rear I/O blank" on page 41)
10. Install any removed PCI riser cage assemblies ("PCI riser cage assembly options" on page 84).
11. Install the node into the chassis.
12. Connect all peripheral cables to the nodes.
13. Power up the node ("Power up the nodes" on page 31).



# Enabling the dedicated iLO management module

To enable the dedicated iLO management module:

1. During the server startup sequence after installing the module, press **F9** in the POST screen.  
The System Utilities screen appears.
2. Select **System Configuration | iLO 4 Configuration Utility**.  
The iLO 4 Configuration Utility screen appears.
3. Select **Network Options**, and then press **Enter**.  
The Network Options screen appears.
4. Set the **Network Interface Adapter** field to **ON**, and then press **Enter**.
5. Press **F10** to save your changes.  
A message prompt to confirm the iLO settings reset appears.
6. Press **Enter** to reboot the iLO settings.
7. Press **Esc** until the main menu is displayed.
8. Select **Reboot the System** to exit the utility and resume the boot process.  
The IP address of the enabled dedicated iLO connector appears on the POST screen on the subsequent boot-up. Access the Network Options screen again to view this IP address for later reference.

## HP Trusted Platform Module option

For more information about product features, specifications, options, configurations, and compatibility, see the product QuickSpecs on the HP website (<http://www.hp.com/go/qs>).

Use these instructions to install and enable a TPM on a supported node. This procedure includes three sections:

1. Installing the Trusted Platform Module board (on page 130).
2. Retaining the recovery key/password (on page 131).
3. Enabling the Trusted Platform Module (on page 131).  
Enabling the TPM requires accessing BIOS/Platform Configuration (RBSU) in HP UEFI System Utilities (on page 149).

TPM installation requires the use of drive encryption technology, such as the Microsoft Windows BitLocker Drive Encryption feature. For more information on BitLocker, see the Microsoft website (<http://www.microsoft.com>).



**CAUTION:** Always observe the guidelines in this document. Failure to follow these guidelines can cause hardware damage or halt data access.

When installing or replacing a TPM, observe the following guidelines:

- Do not remove an installed TPM. Once installed, the TPM becomes a permanent part of the system board.
- When installing or replacing hardware, HP service providers cannot enable the TPM or the encryption technology. For security reasons, only the customer can enable these features.
- When returning a system board for service replacement, do not remove the TPM from the system board. When requested, HP Service provides a TPM with the spare system board.

- Any attempt to remove an installed TPM from the system board breaks or disfigures the TPM security rivet. Upon locating a broken or disfigured rivet on an installed TPM, administrators should consider the system compromised and take appropriate measures to ensure the integrity of the system data.
- When using BitLocker, always retain the recovery key/password. The recovery key/password is required to enter Recovery Mode after BitLocker detects a possible compromise of system integrity.
- HP is not liable for blocked data access caused by improper TPM use. For operating instructions, see the encryption technology feature documentation provided by the operating system.

## Installing the Trusted Platform Module board

**⚠ WARNING:** To reduce the risk of personal injury from hot surfaces, allow the drives and the internal system components to cool before touching them.

1. Power down the node (on page 31).
2. Disconnect all peripheral cables from the node.
3. Remove the node from the chassis (on page 32).
4. Place the node on a flat, level surface.
5. Remove any installed PCI riser cage assemblies ("[Remove the PCI riser cage assembly](#)" on page 48).

**⚠ CAUTION:** Any attempt to remove an installed TPM from the system board breaks or disfigures the TPM security rivet. Upon locating a broken or disfigured rivet on an installed TPM, administrators should consider the system compromised and take appropriate measures to ensure the integrity of the system data.

6. Install the TPM board. Press down on the connector to seat the board ("[System board components](#)" on page 16).

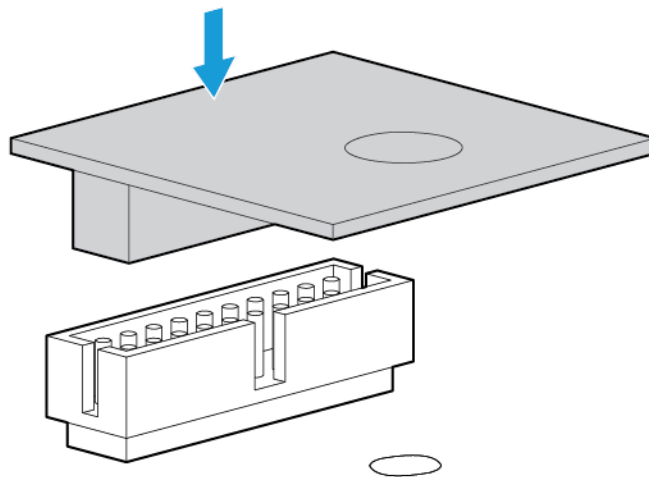

7. Install the TPM security rivet by pressing the rivet firmly into the system board.

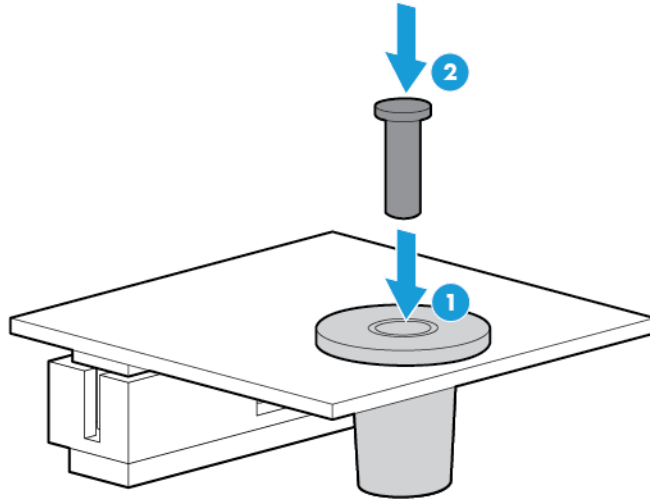

8. Install any removed PCI riser cage assemblies ("[PCI riser cage assembly options](#)" on page 84).
9. Install the node into the chassis.
10. Connect all peripheral cables to the nodes.
11. Power up the node ("[Power up the nodes](#)" on page 31).

## Retaining the recovery key/password

The recovery key/password is generated during BitLocker setup, and can be saved and printed after BitLocker is enabled. When using BitLocker, always retain the recovery key/password. The recovery key/password is required to enter Recovery Mode after BitLocker detects a possible compromise of system integrity.

To help ensure maximum security, observe the following guidelines when retaining the recovery key/password:

- Always store the recovery key/password in multiple locations.
- Always store copies of the recovery key/password away from the node.
- Do not save the recovery key/password on the encrypted hard drive.

## Enabling the Trusted Platform Module

1. During the node startup sequence, press the **F9** key to access System Utilities.
2. From the System Utilities screen, select **System Configuration > BIOS/Platform Configuration (RBSU) > Server Security**.
3. Select **Trusted Platform Module Options** and press the **Enter** key.
4. Select **Enabled** to enable the TPM and BIOS secure startup. The TPM is fully functional in this mode.
5. Press the **F10** key to save your selection.
6. When prompted to save the change in System Utilities, press the **Y** key.
7. Press the **ESC** key to exit System Utilities. Then, press the **Enter** key when prompted to reboot the node.

The node then reboots a second time without user input. During this reboot, the TPM setting becomes effective.

You can now enable TPM functionality in the OS, such as Microsoft Windows BitLocker or measured boot.



**CAUTION:** When a TPM is installed and enabled on the node, data access is locked if you fail to follow the proper procedures for updating the system or option firmware, replacing the system board, replacing a hard drive, or modifying OS application TPM settings.

For more information on firmware updates and hardware procedures, see the *HP Trusted Platform Module Best Practices White Paper* on the HP website (<http://www.hp.com/support>).

For more information on adjusting TPM usage in BitLocker, see the Microsoft website (<http://technet.microsoft.com/en-us/library/cc732774.aspx>).

---

# Cabling

## Chassis cabling

### Front I/O cabling

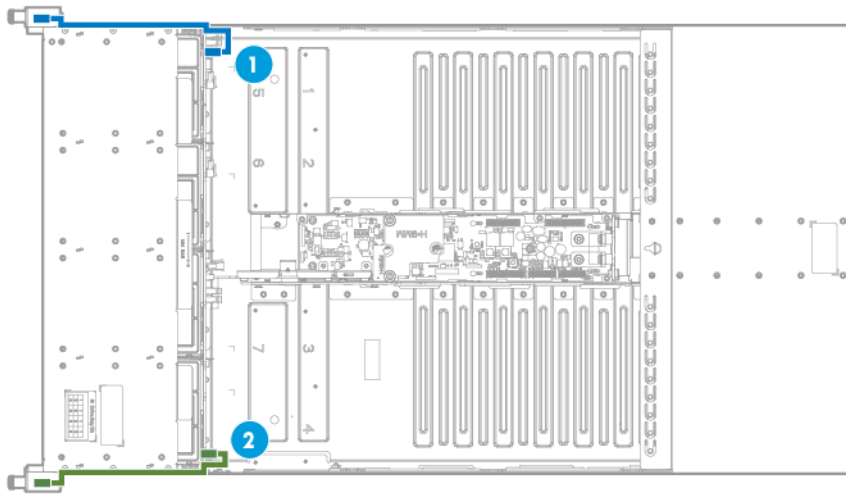

Item	Description
1	Left front I/O cable
2	Right front I/O cable

# Drive backplane power cabling

## HP Apollo r2600 Chassis

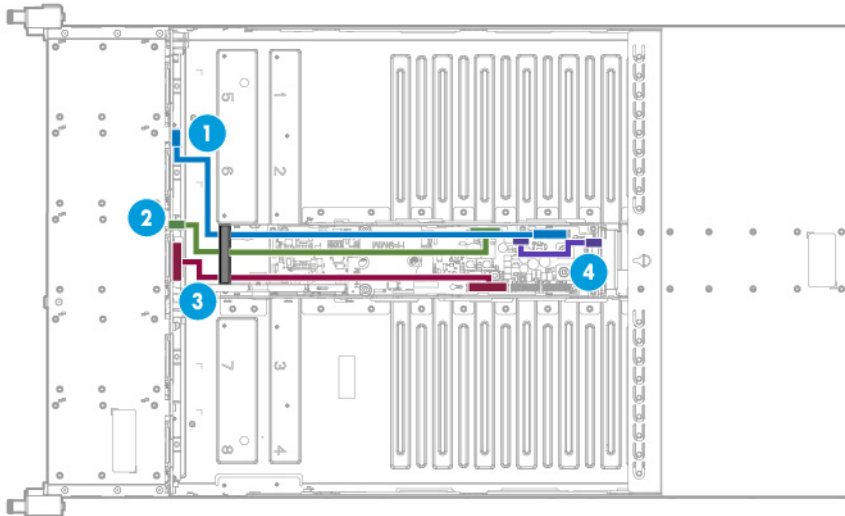

Item	Description
1	Power cable for Node 1 and Node 2
2	Power cable for drives
3	Power cable for Node 3 and Node 4
4	PDB pass-through cable

## HP Apollo r2200 Chassis

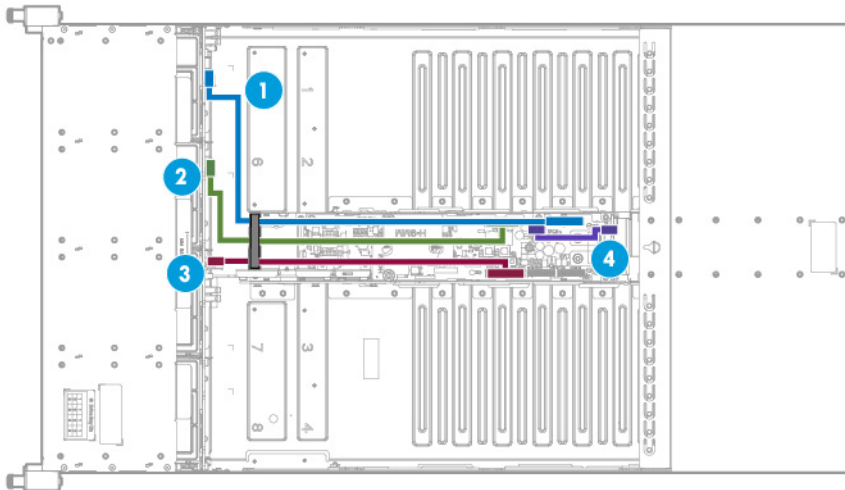

Item	Description
1	Power cable for Node 1 and Node 2

Item	Description
2	Power cable for drives
3	Power cable for Node 3 and Node 4
4	PDB pass-through cable

### RCM 2.0 cabling

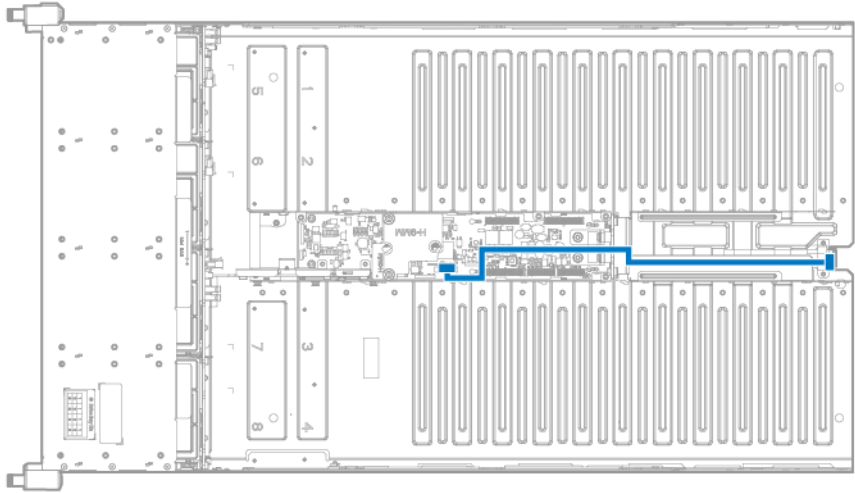

### Fan power cabling

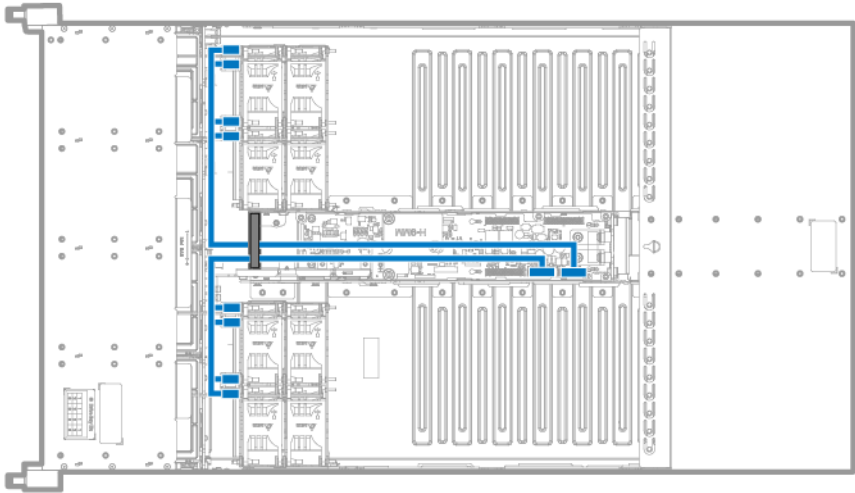

# Fan cabling

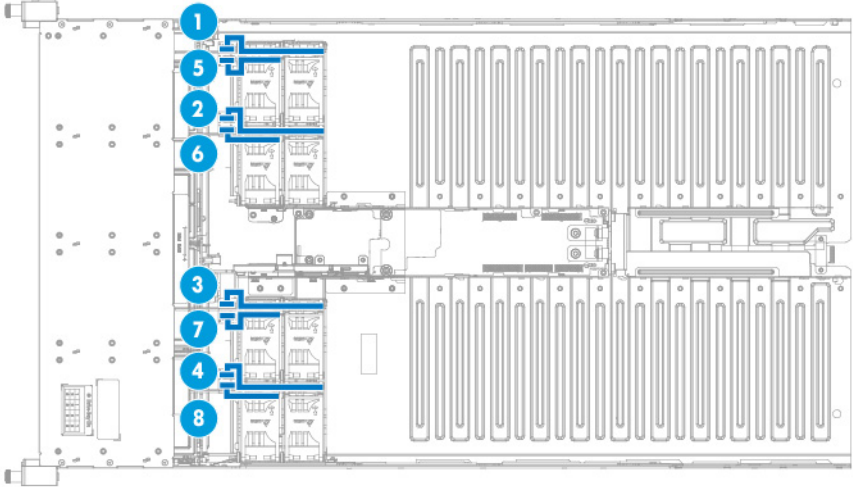

Item	Description
1	Fan 1 cable
2	Fan 2 cable
3	Fan 3 cable
4	Fan 4 cable
5	Fan 5 cable
6	Fan 6 cable
7	Fan 7 cable
8	Fan 8 cable

# HP Smart Storage Battery cabling

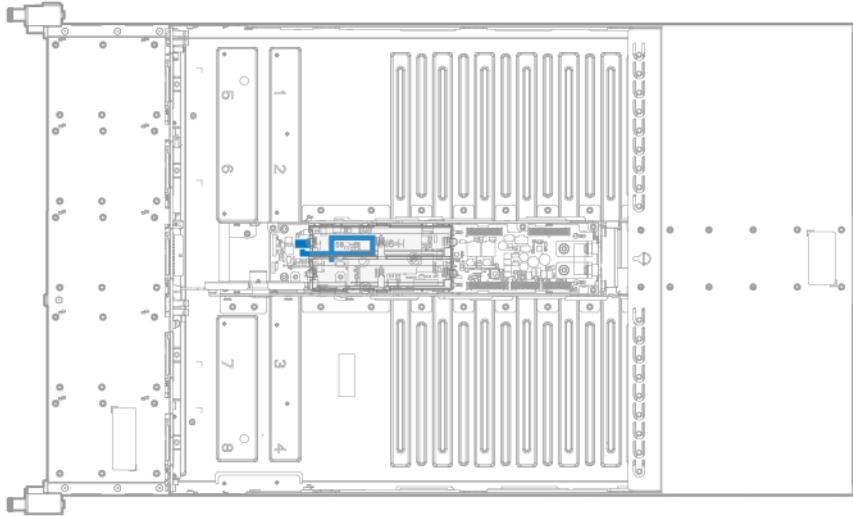



# Node cabling

## Storage cabling

### B140i 1U node SATA cabling

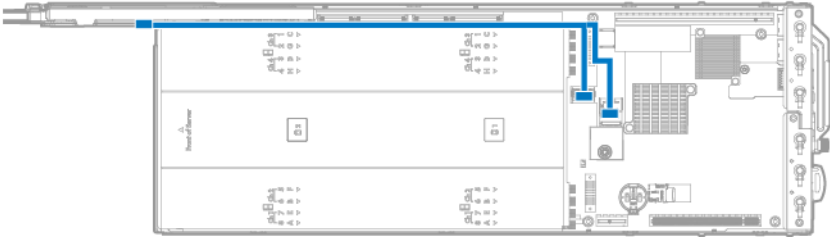

### B140i 2U node SATA cabling

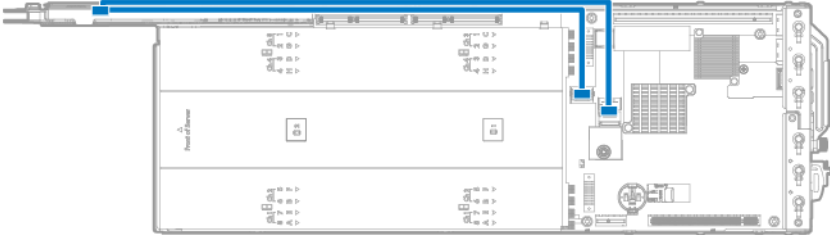

### Mini-SAS H240 1U node cabling



### Mini-SAS H240 2U node cabling



### Mini-SAS P440 2U node cabling



### Mini-SAS P440/P840 cabling

HP P440 Smart Array controller installed in a 1U node



HP P840 Smart Array controller installed in a 2U node



## Graphic card/ coprocessor cabling

**NOTE:** Graphic card/ coprocessor cabling may vary slightly depending on the type of graphic/ coprocessor installed.

### Single graphic card/ coprocessor power cabling

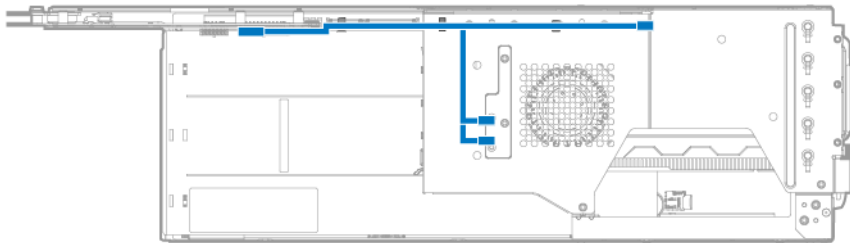

### Dual graphic card/ coprocessor power cabling

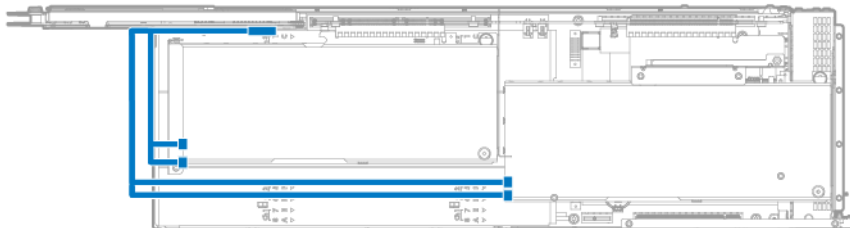

## 2-pin graphic card adapter cabling (for NVIDIA K40 GPUs only)

FlexibleLOM 2U node riser cage assembly

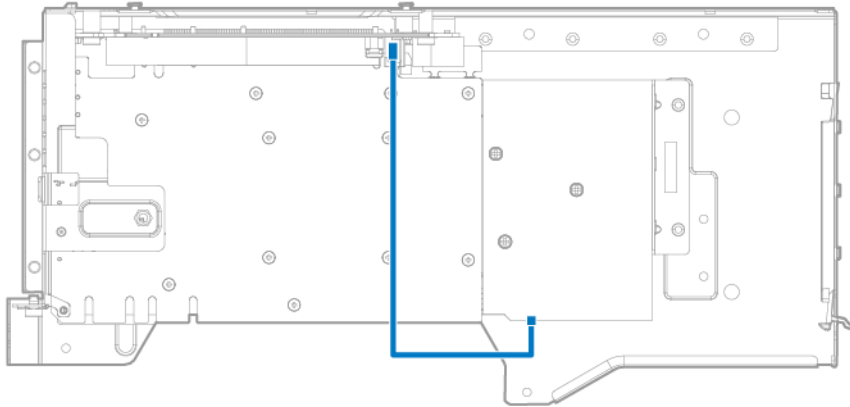

Three-slot PCI riser cage assembly and three-slot GPU-direct PCI riser cage assembly

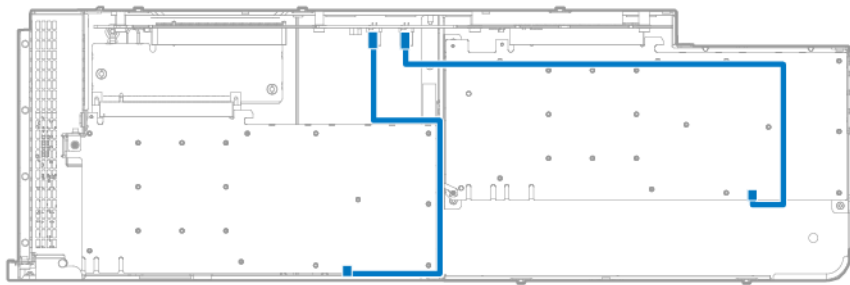

## FBWC module cabling

The FBWC solution is a separately purchased option. This node only supports FBWC module installation when an HP Smart Array P-Series controller is installed.

Depending on the controller option installed, the actual storage controller connectors might look different from what is shown in this section.

HP P440 Smart Array controller in a single-slot left PCI riser cage assembly

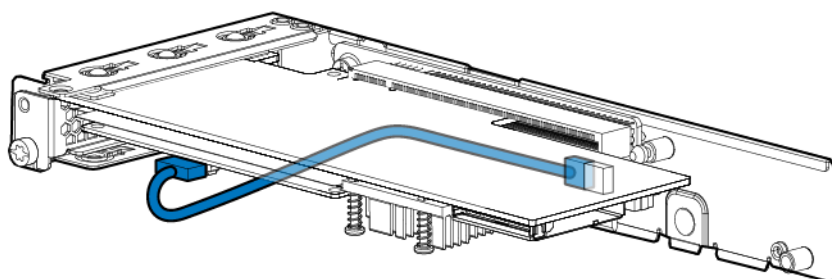

HP P440 Smart Array controller in a single-slot 2U node PCI riser cage assembly

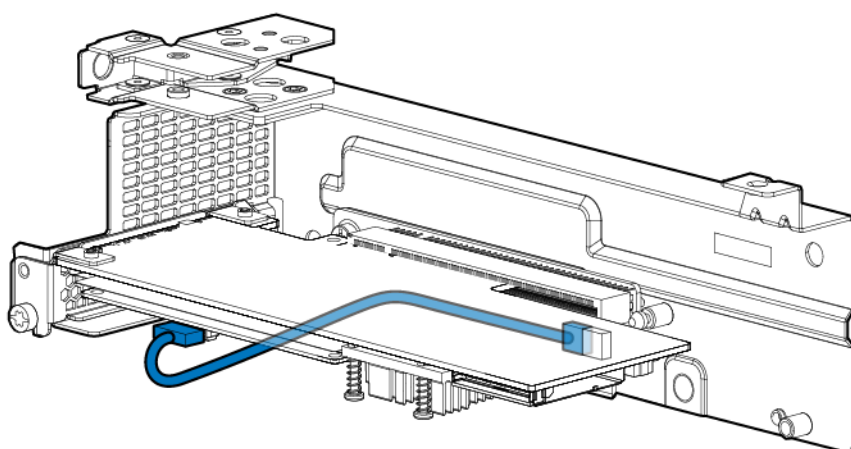

HP P840 Smart Array controller in a FlexibleLOM 2U node riser cage assembly

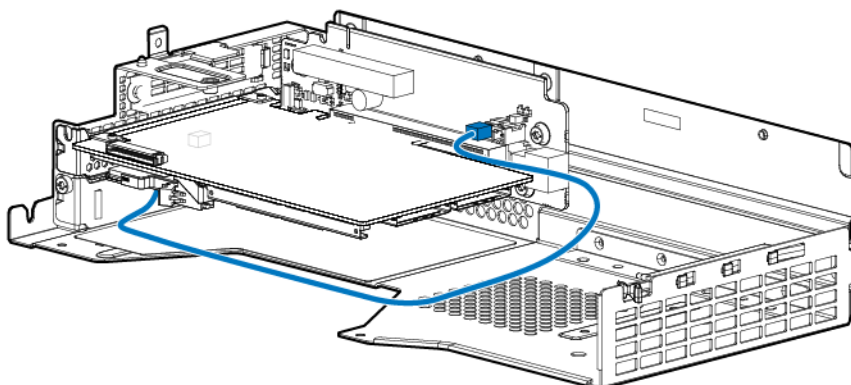

HP P840 Smart Array controller in a three-slot PCI riser cage assembly

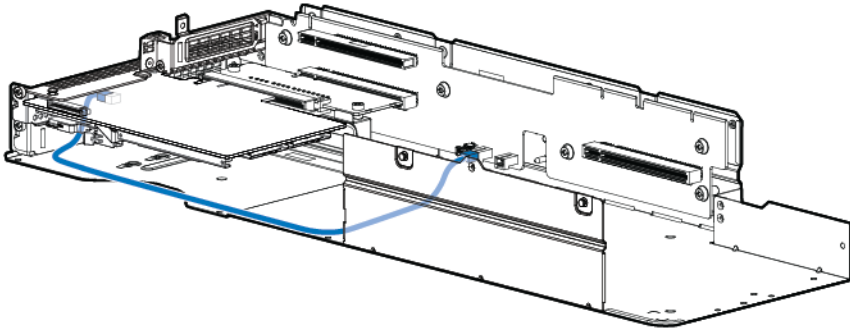

HP P840 Smart Array controller in a three-slot GPU-direct PCI riser cage assembly

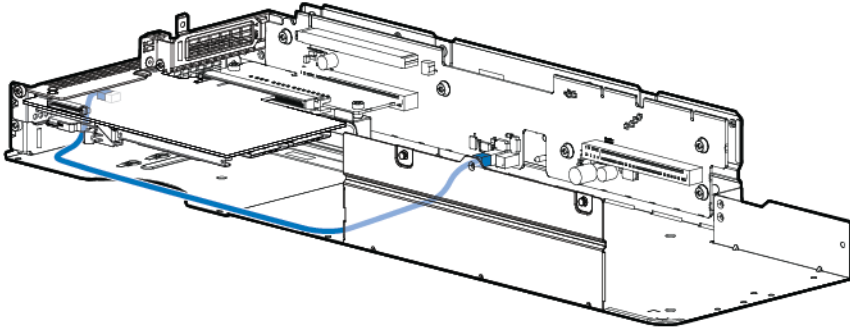

---

# Software and configuration utilities

## Server mode

The software and configuration utilities presented in this section operate in online mode, offline mode, or in both modes.

Software or configuration utility	Server mode
HP iLO (on page 143)	Online and Offline
Active Health System (on page 144)	Online and Offline
HP RESTful API support for HP iLO (on page 145)	Online and Offline
Integrated Management Log (on page 145)	Online and Offline
HP Insight Remote Support (on page 146)	Online
HP Insight Online (on page 146)	Online
Intelligent Provisioning (on page 146)	Offline
HP Insight Diagnostics (on page 147)	Online and Offline
Erase Utility (on page 147)	Offline
Scripting Toolkit for Windows and Linux (on page 148)	Online
HP Service Pack for ProLiant (on page 148)	Online and Offline
HP Smart Update Manager (on page 148)	Online and Offline
HP UEFI System Utilities (on page 149)	Offline
HP Smart Storage Administrator (on page 152)	Online and Offline
FWUPDATE utility (on page 154)	Offline

## Product QuickSpecs

For more information about product features, specifications, options, configurations, and compatibility, see the product QuickSpecs on the HP website (<http://www.hp.com/go/qs>).

## HP iLO

The iLO subsystem is a standard component of HP ProLiant servers that simplifies initial node setup, server health monitoring, power and thermal optimization, and remote server administration. The iLO subsystem includes an intelligent microprocessor, secure memory, and a dedicated network interface. This design makes iLO independent of the host server and its operating system.

iLO enables and manages the Active Health System (on page 144) and also features Agentless Management. All key internal subsystems are monitored by iLO. If enabled, SNMP alerts are sent directly by iLO regardless of the host operating system or even if no host operating system is installed.

Embedded remote support software is available on HP ProLiant Gen8 and later servers with iLO 4, regardless of the operating system software and without installing OS agents on the server.

Using iLO, you can do the following:

- Access a high-performance and secure Integrated Remote Console to the server from anywhere in the world if you have a network connection to the server.
- Use the shared .NET Integrated Remote Console to collaborate with up to four server administrators.
- Remotely mount high-performance Virtual Media devices to the node.
- Securely and remotely control the power state of the managed node.
- Implement true Agentless Management with SNMP alerts from HP iLO, regardless of the state of the host server.
- Download the Active Health System log.
- Register for HP Insight Remote Support.
- Use iLO Federation to manage multiple servers from one system running the iLO web interface.
- Use Virtual Power and Virtual Media from the GUI, the CLI, or the iLO scripting toolkit for many tasks, including the automation of deployment and provisioning.
- Control iLO by using a remote management tool.

For more information about iLO features, see the iLO documentation on the HP website (<http://www.hp.com/go/ilo/docs>).

The HP iLO 4 hardware and firmware features and functionality, such as NAND size and embedded user partition, vary depending on the node model. For a complete list of supported features and functionality, see the HP iLO 4 QuickSpecs on the HP website ([http://h18000.www1.hp.com/products/quickspecs/14276\\_div/14276\\_div.pdf](http://h18000.www1.hp.com/products/quickspecs/14276_div/14276_div.pdf)).

## Active Health System

HP Active Health System provides the following features:

- Combined diagnostics tools/scanners
- Always on, continuous monitoring for increased stability and shorter downtimes
- Rich configuration history
- Health and service alerts
- Easy export and upload to Service and Support

The HP Active Health System monitors and records changes in the server hardware and system configuration. The Active Health System assists in diagnosing problems and delivering rapid resolution if server failures occur.

The Active Health System collects the following types of data:

- Server model
- Serial number
- Processor model and speed
- Storage capacity and speed
- Memory capacity and speed
- Firmware/BIOS



HP Active Health System does not collect information about Active Health System users' operations, finances, customers, employees, partners, or data center, such as IP addresses, host names, user names, and passwords. HP Active Health System does not parse or change operating system data from third-party error event log activities, such as content created or passed through by the operating system.

The data that is collected is managed according to the HP Data Privacy policy. For more information see the HP website (<http://www.hp.com/go/privacy>).

The Active Health System, in conjunction with the system monitoring provided by Agentless Management or SNMP Pass-thru, provides continuous monitoring of hardware and configuration changes, system status, and service alerts for various server components.

The Agentless Management Service is available in the SPP, which can be downloaded from the HP website (<http://www.hp.com/go/spp/download>). The Active Health System log can be downloaded manually from iLO or HP Intelligent Provisioning and sent to HP.

For more information, see the following documents:

- *HP iLO User Guide* on the HP website (<http://www.hp.com/go/ilo/docs>)
- *HP Intelligent Provisioning User Guide* on the HP website (<http://www.hp.com/go/intelligentprovisioning/docs>)

## HP RESTful API support for HP iLO

HP iLO 4 firmware version 2.00 and later includes the HP RESTful API. The HP RESTful API is a management interface that server management tools can use to perform configuration, inventory, and monitoring of an HP ProLiant server via iLO. A REST client sends HTTPS operations to the iLO web server to GET and PATCH JSON-formatted data, and to configure supported iLO and server settings, such as the UEFI BIOS settings.

HP iLO 4 supports the HP RESTful API with HP ProLiant Gen8 and later servers. For more information about the HP RESTful API, see the HP website (<http://www.hp.com/support/restfulinterface/docs>).

## Integrated Management Log

The IML records hundreds of events and stores them in an easy-to-view form. The IML timestamps each event with 1-minute granularity.

You can view recorded events in the IML in several ways, including the following:

- From within HP SIM
- From within HP UEFI System Utilities (on page [149](#))
- From within the Embedded UEFI shell (on page [151](#))
- From within operating system-specific IML viewers:
  - For Windows: IML Viewer
  - For Linux: IML Viewer Application
- From within the iLO web interface
- From within HP Insight Diagnostics (on page [147](#))

## HP Insight Remote Support

HP strongly recommends that you register your device for remote support to enable enhanced delivery of your HP Warranty, HP Care Pack Service, or HP contractual support agreement. HP Insight Remote Support supplements your monitoring continuously to ensure maximum system availability by providing intelligent event diagnosis, and automatic, secure submission of hardware event notifications to HP, which will initiate a fast and accurate resolution, based on your product's service level. Notifications can be sent to your authorized HP Channel Partner for onsite service, if configured and available in your country.

For more information, see *HP Insight Remote Support and Insight Online Setup Guide for ProLiant Servers and BladeSystem c-Class Enclosures* on the HP website (<http://www.hp.com/go/insightremotesupport/docs>). HP Insight Remote Support is available as part of HP Warranty, HP Care Pack Service, or HP contractual support agreement.

### HP Insight Remote Support central connect

When you use the embedded Remote Support functionality with HP ProLiant Gen8 and later server models and HP BladeSystem c-Class enclosures, you can register a node or chassis to communicate to HP through an HP Insight Remote Support centralized Hosting Device in your local environment. All configuration and service event information is routed through the Hosting Device. This information can be viewed by using the local HP Insight Remote Support user interface or the web-based view in HP Insight Online.

For more information, see *HP Insight Remote Support Release Notes* on the HP website (<http://www.hp.com/go/insightremotesupport/docs>).

### HP Insight Online direct connect

When you use the embedded Remote Support functionality with HP ProLiant Gen8 and later server models and HP BladeSystem c-Class enclosures, you can register a node or chassis to communicate directly to HP Insight Online without the need to set up an HP Insight Remote Support centralized Hosting Device in your local environment. HP Insight Online will be your primary interface for remote support information.

For more information, see the product documentation on the HP website (<http://www.hp.com/go/insightremotesupport/docs>).

### HP Insight Online

HP Insight Online is a capability of the HP Support Center portal. Combined with HP Insight Remote Support central connect or HP Insight Online direct connect, it automatically aggregates device health, asset, and support information with contract and warranty information, and then secures it in a single, personalized dashboard that is viewable from anywhere at any time. The dashboard organizes your IT and service data to help you understand and respond to that information more quickly. With specific authorization from you, an authorized HP Channel Partner can also view your IT environment remotely using HP Insight Online.

For more information about using HP Insight Online, see the *HP Insight Online User's Guide* on the HP website (<http://www.hp.com/go/insightremotesupport/docs>).

## Intelligent Provisioning

Intelligent Provisioning is a single-server deployment tool embedded in HP ProLiant Gen8 and later servers that simplifies HP ProLiant server setup, providing a reliable and consistent way to deploy HP ProLiant server configurations:

- Intelligent Provisioning assists with the OS installation process by preparing the system for installing "off-the-shelf" and HP branded versions of operating system software and integrating optimized HP ProLiant server support software.
- Intelligent Provisioning provides maintenance-related tasks using the Perform Maintenance window.
- Intelligent Provisioning provides installation help for Microsoft Windows, Red Hat and SUSE Linux, and VMware operating systems. For specific OS support, see the *HP Intelligent Provisioning Release Notes* on the HP website (<http://www.hp.com/go/intelligentprovisioning/docs>).

For more information about Intelligent Provisioning software, see the HP website (<http://www.hp.com/go/intelligentprovisioning>). For Intelligent Provisioning recovery media downloads, see the Resources tab on the HP website (<http://www.hp.com/go/ilo>). For consolidated drive and firmware update packages, see the HP Smart Update: Server Firmware and Driver Updates page on the HP website (<http://www.hp.com/go/SmartUpdate>).

## HP Insight Diagnostics

HP Insight Diagnostics is a proactive node management tool, available in both offline and online versions, that provides diagnostics and troubleshooting capabilities to assist IT administrators who verify node installations, troubleshoot problems, and perform repair validation.

HP Insight Diagnostics Offline Edition performs various in-depth system and component testing while the OS is not running. To run this utility, boot the node using Intelligent Provisioning (on page 146).

HP Insight Diagnostics Online Edition is a web-based application that captures system configuration and other related data needed for effective node management. Available in Microsoft Windows and Linux versions, the utility helps to ensure proper system operation.

For more information or to download the utility, see the HP website (<http://www.hp.com/servers/diags>). HP Insight Diagnostics Online Edition is also available in the SPP ("HP Service Pack for ProLiant" on page 148).

### HP Insight Diagnostics survey functionality

HP Insight Diagnostics (on page 147) provides survey functionality that gathers critical hardware and software information on ProLiant nodes.

This functionality supports operating systems that are supported by the node. For operating systems supported by the node, see the HP website (<http://www.hp.com/go/supportos>).

If a significant change occurs between data-gathering intervals, the survey function marks the previous information and overwrites the survey data files to reflect the latest changes in the configuration.

Survey functionality is installed with every Intelligent Provisioning-assisted HP Insight Diagnostics installation, or it can be installed through the SPP ("HP Service Pack for ProLiant" on page 148).

## Erase Utility



**CAUTION:** Perform a backup before running the Erase Utility. The utility sets the system to its original factory state, deletes the current hardware configuration information, including array setup and disk partitioning, and erases all connected hard drives completely. Before using this utility, see the instructions in the *HP Intelligent Provisioning User Guide*.

Use the Erase Utility to erase drives and Active Health System logs, and to reset UEFI System Utilities settings. Run the Erase Utility if you must erase the system for the following reasons:

- You want to install a new operating system on a node with an existing operating system.
- You encounter an error when completing the steps of a factory-installed operating system installation.

To access the Erase Utility, click the Perform Maintenance icon from the Intelligent Provisioning home screen, and then select **Erase**.

For more information about the Erase Utility, see the *HP Intelligent Provisioning User Guide* on the HP website (<http://www.hp.com/go/intelligentprovisioning/docs>).

## Scripting Toolkit for Windows and Linux

The Scripting Toolkit for Windows and Linux is a server deployment product that delivers an unattended automated installation for high-volume server deployments. The Scripting Toolkit is designed to support ProLiant BL, ML, DL, SL, and XL servers. The toolkit includes a modular set of utilities and important documentation that describes how to apply these tools to build an automated server deployment process.

The Scripting Toolkit provides a flexible way to create standard server configuration scripts. These scripts are used to automate many of the manual steps in the server configuration process. This automated server configuration process cuts time from each deployment, making it possible to scale rapid, high-volume server deployments.

For more information, and to download the Scripting Toolkit, see the HP website (<http://www.hp.com/go/ProLiant/STK>).

## HP Service Pack for ProLiant

SPP is a comprehensive systems software (drivers and firmware) solution delivered as a single package with major server releases. This solution uses HP SUM as the deployment tool and is tested on all supported HP ProLiant servers including HP ProLiant Gen8 and later servers.

SPP can be used in an online mode on a Windows or Linux hosted operating system, or in an offline mode where the server is booted to an operating system included on the ISO file so that the server can be updated automatically with no user interaction or updated in interactive mode.

For more information or to download SPP, see one of the following pages on the HP website:

- HP Service Pack for ProLiant download page (<http://www.hp.com/go/spp>)
- HP Smart Update: Server Firmware and Driver Updates page (<http://www.hp.com/go/SmartUpdate>)

## HP Smart Update Manager

HP SUM is a product used to install and update firmware, drivers, and systems software on HP ProLiant servers. HP SUM provides a GUI and a command-line scriptable interface for deployment of systems software for single or one-to-many HP ProLiant servers and network-based targets, such as iLOs, OAs, and VC Ethernet and Fibre Channel modules.

For more information about HP SUM, see the product page on the HP website (<http://www.hp.com/go/hpsum>).

To download HP SUM, see the HP website (<http://www.hp.com/go/hpsum/download>).

To access the *HP Smart Update Manager User Guide*, see the HP SUM Information Library (<http://www.hp.com/go/hpsum/documentation>).

# HP UEFI System Utilities

The HP UEFI System Utilities is embedded in the system ROM. The UEFI System Utilities enable you to perform a wide range of configuration activities, including:

- Configuring system devices and installed options
- Enabling and disabling system features
- Displaying system information
- Selecting the primary boot controller
- Configuring memory options
- Selecting a language
- Launching other pre-boot environments such as the Embedded UEFI Shell and Intelligent Provisioning

For more information on the HP UEFI System Utilities, see the *HP UEFI System Utilities User Guide for HP ProLiant Gen9 Servers* on the HP website (<http://www.hp.com/go/ProLiantUEFI/docs>).

Scan the QR code located at the bottom of the screen to access mobile-ready online help for the UEFI System Utilities and UEFI Shell. For on-screen help, press **F1**.

## Using HP UEFI System Utilities

To use the System Utilities, use the following keys.

Action	Key
Access System Utilities	F9 during server POST
Navigate menus	Up and Down arrows
Select items	Enter
Save selections	F10
Access Help for a highlighted configuration option*	F1

\*Scan the QR code on the screen to access online help for the UEFI System Utilities and UEFI Shell.

Default configuration settings are applied to the server at one of the following times:

- Upon the first system power-up
- After defaults have been restored

Default configuration settings are sufficient for typical server operations; however, you can modify configuration settings as needed. The system prompts you for access to the System Utilities each time the system is powered up.

## Flexible boot control

This feature enables you to do the following:

- Add Boot Options
  - Browse all FAT16 and FAT32 file systems.
  - Select an X64 UEFI application with an .EFI extension to add as a new UEFI boot option, such as an OS boot loader or other UEFI application.

The new boot option is appended to the boot order list. When you select a file, you are prompted to enter the boot option description (which is then displayed in the Boot menu), as well as any optional data to be passed to an .EFI application.

- **Boot to System Utilities**  
After pre-POST, the boot options screen appears. During this time, you can access the System Utilities by pressing the **F9** key.
- **Choose between supported modes: Legacy BIOS Boot Mode or UEFI Boot Mode**



**IMPORTANT:** If the default boot mode settings are different than the user defined settings, the system may not boot the OS installation if the defaults are restored. To avoid this issue, use the User Defined Defaults feature in UEFI System Utilities to override the factory default settings.

For more information, see the *HP UEFI System Utilities User Guide for HP ProLiant Gen9 Servers* on the HP website (<http://www.hp.com/go/ProLiantUEFI/docs>).

## Restoring and customizing configuration settings

You can reset all configuration settings to the factory default settings, or you can restore system default configuration settings, which are used instead of the factory default settings.

You can also configure default settings as necessary, and then save the configuration as the custom default configuration. When the system loads the default settings, it uses the custom default settings instead of the factory defaults.

## Secure Boot configuration

Secure Boot is integrated in the UEFI specification on which the HP implementation of UEFI is based. Secure Boot is completely implemented in the BIOS and does not require special hardware. It ensures that each component launched during the boot process is digitally signed and that the signature is validated against a set of trusted certificates embedded in the UEFI BIOS. Secure Boot validates the software identity of the following components in the boot process:

- UEFI drivers loaded from PCIe cards
- UEFI drivers loaded from mass storage devices
- Pre-boot UEFI shell applications
- OS UEFI boot loaders

Once enabled, only firmware components and operating systems with boot loaders that have an appropriate digital signature can execute during the boot process. Only operating systems that support Secure Boot and have an EFI boot loader signed with one of the authorized keys can boot when Secure Boot is enabled. For more information about supported operating systems, see the *HP UEFI System Utilities and Shell Release Notes* on the HP website (<http://www.hp.com/go/ProLiantUEFI/docs>).

A physically present user can customize the certificates embedded in the UEFI BIOS by adding/removing their own certificates.

## Embedded UEFI shell

The system BIOS in all HP ProLiant Gen9 servers includes an Embedded UEFI Shell in the ROM. The UEFI Shell environment provides an API, a command line prompt, and a set of CLIs that allow scripting, file manipulation, and system information. These features enhance the capabilities of the UEFI System Utilities.

For more information, see the following documents:

- *HP UEFI Shell User Guide for HP ProLiant Gen9 Servers* on the HP website (<http://www.hp.com/go/ProLiantUEFI/docs>)
- *UEFI Shell Specification* on the UEFI website (<http://www.uefi.org/specifications>)

## Embedded Diagnostics option

The system BIOS in all HP ProLiant Gen9 servers includes an Embedded Diagnostics option in the ROM. The Embedded Diagnostics option can run comprehensive diagnostics of the server hardware, including processors, memory, drives, and other server components.

For more information on the Embedded Diagnostics option, see the *HP UEFI System Utilities User Guide for HP ProLiant Gen9 Servers* on the HP website (<http://www.hp.com/go/ProLiantUEFI/docs>).

## HP RESTful API support for UEFI

HP ProLiant Gen9 servers include support for a UEFI compliant System BIOS, along with UEFI System Utilities and Embedded UEFI Shell pre-boot environments. HP ProLiant Gen9 servers also support configuring the UEFI BIOS settings using the HP RESTful API, a management interface that server management tools can use to perform configuration, inventory, and monitoring of an HP ProLiant server. A REST client uses HTTPS operations to configure supported server settings, such as UEFI BIOS settings.

For more information about the HP RESTful API and the HP RESTful Interface Tool, see the HP website (<http://www.hp.com/support/restfulinterface/docs>).

## Re-entering the server serial number and product ID

After you replace the system board, you must re-enter the node serial number and the product ID.

1. During the node startup sequence, press the **F9** key to access UEFI System Utilities.
2. Select the **System Configuration > BIOS/Platform Configuration (RBSU) > Advanced Options > Advanced System ROM Options > Serial Number**, and then press the **Enter** key.
3. Enter the serial number and press the **Enter** key. The following message appears:  
The serial number should only be modified by qualified service personnel. This value should always match the serial number located on the chassis.
4. Press the **Enter** key to clear the warning.
5. Enter the serial number and press the **Enter** key.
6. Select **Product ID**. The following warning appears:  
Warning: The Product ID should ONLY be modified by qualified service personnel. This value should always match the Product ID located on the chassis.
7. Enter the product ID and press the **Enter** key.
8. Press the **F10** key to confirm exiting System Utilities. The node automatically reboots.

# Utilities and features

## HP Smart Storage Administrator

HP SSA is a configuration and management tool for HP Smart Array controllers. Starting with HP ProLiant Gen8 servers, HP SSA replaces ACU with an enhanced GUI and additional configuration features.

HP SSA exists in three interface formats: the HP SSA GUI, the HP SSA CLI, and HP SSA Scripting. Although all formats provide support for configuration tasks, some of the advanced tasks are available in only one format.

Some HP SSA features include the following:

- Supports online array capacity expansion, logical drive extension, assignment of online spares, and RAID or stripe size migration
- Suggests the optimal configuration for an unconfigured system
- Provides diagnostic and SmartSSD Wear Gauge functionality on the Diagnostics tab
- For supported controllers, provides access to additional features.

For more information about HP SSA, see the HP website (<http://www.hp.com/go/hpssa>).

## Automatic Server Recovery

ASR is a feature that causes the system to restart when a catastrophic operating system error occurs, such as a blue screen, ABEND, or panic. A system fail-safe timer, the ASR timer, starts when the System Management driver, also known as the Health Driver, is loaded. When the operating system is functioning properly, the system periodically resets the timer. However, when the operating system fails, the timer expires and restarts the server.

ASR increases server availability by restarting the server within a specified time after a system hang. You can disable ASR from the System Management Homepage or through UEFI System Utilities.

## USB support

HP nodes support both USB 2.0 ports and USB 3.0 ports. Both types of ports support installing all types of USB devices (USB 1.0, USB 2.0, and USB 3.0), but may run at lower speeds in specific situations:

- USB 3.0 capable devices operate at USB 2.0 speeds when installed in a USB 2.0 port.
- When the node is configured for UEFI Boot Mode, HP provides legacy USB support in the pre-boot environment prior to the operating system loading for USB 1.0, USB 2.0, and USB 3.0 speeds.
- When the node is configured for Legacy BIOS Boot Mode, HP provides legacy USB support in the pre-boot environment prior to the operating system loading for USB 1.0 and USB 2.0 speeds. While USB 3.0 ports can be used with all devices in Legacy BIOS Boot Mode, they are not available at USB 3.0 speeds in the pre-boot environment. Standard USB support (USB support from within the operating system) is provided by the OS through the appropriate USB device drivers. Support for USB 3.0 varies by operating system.

For maximum compatibility of USB 3.0 devices with all operating systems, HP provides a configuration setting for USB 3.0 Mode. Auto is the default setting. This setting impacts USB 3.0 devices when connected to USB 3.0 ports in the following manner:



- **Auto (default)**—If configured in Auto Mode, USB 3.0 capable devices operate at USB 2.0 speeds in the pre-boot environment and during boot. When a USB 3.0 capable OS USB driver loads, USB 3.0 devices transition to USB 3.0 speeds. This mode provides compatibility with operating systems that do not support USB 3.0 while still allowing USB 3.0 devices to operate at USB 3.0 speeds with state-of-the-art operating systems.
- **Enabled**—If Enabled, USB 3.0 capable devices operate at USB 3.0 speeds at all times (including the pre-boot environment) when in UEFI Boot Mode. This mode should not be used with operating systems that do not support USB 3.0. If operating in Legacy Boot BIOS Mode, the USB 3.0 ports cannot function in the pre-boot environment and are not bootable.
- **Disabled**—If configured for Disabled, USB 3.0 capable devices function at USB 2.0 speeds at all times.

The pre-OS behavior of the USB ports is configurable in System Utilities, so that the user can change the default operation of the USB ports. For more information, see the *HP UEFI System Utilities User Guide for HP ProLiant Gen9 Servers* on the HP website (<http://www.hp.com/go/ProLiantUEFI/docs>).

## External USB functionality

HP provides external USB support to enable local connection of USB devices for node administration, configuration, and diagnostic procedures.

For additional security, external USB functionality can be disabled through USB options in UEFI System Utilities.

## Redundant ROM support

The node enables you to upgrade or configure the ROM safely with redundant ROM support. The node has a single ROM that acts as two separate ROM images. In the standard implementation, one side of the ROM contains the current ROM program version, while the other side of the ROM contains a backup version.

---

**NOTE:** The server ships with the same version programmed on each side of the ROM.

---

## Safety and security benefits

When you flash the system ROM, ROMPaq writes over the backup ROM and saves the current ROM as a backup, enabling you to switch easily to the alternate ROM version if the new ROM becomes corrupted for any reason. This feature protects the existing ROM version, even if you experience a power failure while flashing the ROM.

## Keeping the system current

### Access to HP Support Materials

Access to some updates for HP ProLiant Servers may require product entitlement when accessed through the HP Support Center support portal. HP recommends that you have an HP Passport set up with relevant entitlements. For more information, see the HP website (<http://h20564.www2.hp.com/portal/site/hpsc/public/kb/docDisplay/?docId=c03859703>).

# Updating firmware or System ROM

Multiple methods exist to update the firmware or System ROM:

- HP Service Pack for ProLiant (on page 148)
- FWUPDATE utility (on page 154)
- FWUpdate command from within the Embedded UEFI shell (on page 154)
- Firmware Update application in System Utilities (on page 155)
- Online Flash components (on page 155)

Product entitlement is required to perform updates. For more information, see "Access to HP Support Materials (on page 153)."

## FWUPDATE utility

The FWUPDATE utility enables you to upgrade the system firmware (BIOS).

To use the utility to upgrade the firmware:

1. Download the FWUPDATE flash component from the HP website (<http://www.hp.com/go/hpsc>).
2. Save the FWUPDATE flash components to a USB key.
3. Set the boot order so the USB key will boot first using one of the following options:
  - Configure the boot order so the USB key is the first bootable device.
  - Press **F11** (Boot Menu) when prompted during system boot to access the **One-Time Boot Menu**. This menu allows you to select the boot device for a specific boot and does not modify the boot order configuration settings.
4. Insert the USB key into an available USB port.
5. Boot the system.

The FWUPDATE utility checks the system and provides a choice (if more than one exists) of available firmware revisions.

To download the flash components, see the HP website (<http://www.hp.com/go/hpsc>).

For more information about the One-Time Boot Menu, see the *HP UEFI System Utilities User Guide for HP ProLiant Gen9 Servers* on the HP website (<http://www.hp.com/go/ProLiantUEFI/docs>).

## FWUpdate command from within the Embedded UEFI Shell

For systems configured in either boot mode, update the firmware:

1. Access the System ROM Flash Binary component for your node from the HP Support Center (<http://www.hp.com/go/hpsc>). When searching for the component, always select **OS Independent** to locate the binary file.
2. Copy the binary file to a USB media or iLO virtual media.
3. Attach the media to the node.
4. Boot to Embedded Shell.
5. To obtain the assigned file system volume for the USB key, enter `Map -r`. For more information about accessing a file system from the shell, see the *HP UEFI Shell User Guide for HP ProLiant Gen9 Servers* on the HP website (<http://www.hp.com/go/ProLiantUEFI/docs>).

6. Change to the file system that contains the System ROM Flash Binary component for your node. Enter one of the fsx file systems available, such as fs0 or fs1, and press **Enter**.
7. Use the cd command to change from the current directory to the directory that contains the binary file.
8. Enter `fwupdate -d BIOS -f <filename>` to flash the system ROM.  
For help on the FWUPDATE command, enter the command:  
`help fwupdate -b`
9. Reboot the node. A reboot is required after the firmware update for the updates to take effect and for hardware stability to be maintained.

For more information about the commands used in this procedure, see the *HP UEFI Shell User Guide for HP ProLiant Gen9 Servers* on the HP website (<http://www.hp.com/go/ProLiantUEFI/docs>).

## Firmware Update application in System Utilities

For systems configured in either boot mode, update the firmware:

1. Access the System ROM Flash Binary component for your node from the HP Support Center (<http://www.hp.com/go/hpsc>). When searching for the component, always select **OS Independent** to find the component.
2. Copy the binary file to a USB media or iLO virtual media.
3. Attach the media to the node.
4. During POST, press **F9** to enter System Utilities.
5. Select **Embedded Applications** → **Firmware Update** → **System ROM** → **Select Firmware File**.
6. Select the device containing the flash file.
7. Select the flash file. This step may take a few moments to complete.
8. Select **Start firmware update** and allow the process to complete.
9. Reboot the node. A reboot is required after the firmware update for the updates to take effect and for hardware stability to be maintained.

## Online Flash components

This component provides updated system firmware that can be installed directly on supported Operating Systems. Additionally, when used in conjunction with HP SUM ("HP Smart Update Manager" on page 148), this Smart Component allows the user to update firmware on remote servers from a central location. This remote deployment capability eliminates the need for the user to be physically present at the server to perform a firmware update.

## Drivers



---

**IMPORTANT:** Always perform a backup before installing or updating device drivers.

---

The node includes new hardware that may not have driver support on all OS installation media.

If you are installing an Intelligent Provisioning-supported OS, use Intelligent Provisioning (on page 146) and its Configure and Install feature to install the OS and latest supported drivers.

If you do not use Intelligent Provisioning to install an OS, drivers for some of the new hardware are required. These drivers, as well as other option drivers, ROM images, and value-add software can be downloaded as part of an SPP.

If you are installing drivers from SPP, be sure that you are using the latest SPP version that your node supports. To verify that your node is using the latest supported version and for more information about SPP, see the HP website (<http://www.hp.com/go/spp/download>).

To locate the drivers for a particular server, go to the HP website (<http://www.hp.com/go/hpsc>) and click on **Drivers, Software & Firmware**. Then, enter your product name in the **Find an HP product** field and click **Go**.

## Software and firmware

Software and firmware should be updated before using the server for the first time, unless any installed software or components require an older version.

For system software and firmware updates, use one of the following sources:

- Download the SPP ("HP Service Pack for ProLiant" on page 148) from the HP Service Pack for ProLiant download page (<http://www.hp.com/go/spp>).
- Download individual drivers, firmware, or other systems software components from the node product page in the HP Support Center (<http://www.hp.com/go/hpsc>).

## Operating System Version Support

For information about specific versions of a supported operating system, refer to the operating system support matrix (<http://www.hp.com/go/supportos>).

## Version control

The VCRM and VCA are web-enabled Insight Management Agents tools that HP SIM uses to schedule software update tasks to the entire enterprise.

- VCRM manages the repository for SPP. Administrators can view the SPP contents or configure VCRM to automatically update the repository with internet downloads of the latest software and firmware from HP.
- VCA compares installed software versions on the node with updates available in the VCRM managed repository. Administrators configure VCA to point to a repository managed by VCRM.

For more information about version control tools, see the *HP Systems Insight Manager User Guide*, the *HP Version Control Agent User Guide*, and the *HP Version Control Repository Manager User Guide* on the HP website (<http://www.hp.com/go/enterprise/docs>).

1. Select **HP Insight Management** from the available options in Products and Solutions.
2. Select **HP Version Control** from the available options in HP Insight Management.
3. Download the latest document.

## HP operating systems and virtualization software support for ProLiant servers

For information about specific versions of a supported operating system, see the HP website (<http://www.hp.com/go/ossupport>).

## HP Technology Service Portfolio

Connect to HP for assistance on the journey to the new style of IT. HP Technology Services delivers confidence and reduces risk to help you realize agility and stability in your IT infrastructure.

Utilize our consulting expertise in the areas of private or hybrid cloud computing, big data and mobility requirements, improving data center infrastructure and better use of today's server, storage and networking technology. For more information, see the HP website (<http://www.hp.com/services/consulting>).

Our support portfolio covers services for HP server, storage and networking hardware and software plus the leading industry standard operating systems. Let us work proactively with you to prevent problems. Our flexible choices of hardware and software support coverage windows and response times help resolve problems faster, reduce unplanned outages and free your staff for more important tasks. For more information, see the HP website (<http://www.hp.com/services/support>).

Tap into our knowledge, expertise, innovation and world-class services to achieve better results. Access and apply technology in new ways to optimize your operations and you'll be positioned for success.

## Change control and proactive notification

HP offers Change Control and Proactive Notification to notify customers 30 to 60 days in advance of upcoming hardware and software changes on HP commercial products.

For more information, refer to the HP website (<http://www.hp.com/go/pcn>).

# System battery

If the node no longer automatically displays the correct date and time, then replace the battery that provides power to the real-time clock. Under normal use, battery life is 5 to 10 years.



**WARNING:** The computer contains an internal lithium manganese dioxide, a vanadium pentoxide, or an alkaline battery pack. A risk of fire and burns exists if the battery pack is not properly handled. To reduce the risk of personal injury:

- Do not attempt to recharge the battery.
- Do not expose the battery to temperatures higher than 60°C (140°F).
- Do not disassemble, crush, puncture, short external contacts, or dispose of in fire or water.
- Replace only with the spare designated for this product.

To remove the component:

1. Power down the node (on page 31).
2. Disconnect all peripheral cables from the node.
3. Remove the node from the chassis (on page 32).
4. Place the node on a flat, level surface.
5. Remove any installed PCI riser cage assemblies ("Remove the PCI riser cage assembly" on page 48).
6. Locate the battery on the system board ("System board components" on page 16).
7. If the system battery is secured by a metal tab, do the following:
  - a. Use your finger or a small flat-bladed, nonconductive tool to press the metal tab. This will partially release the battery from the socket.
  - b. Remove the battery.

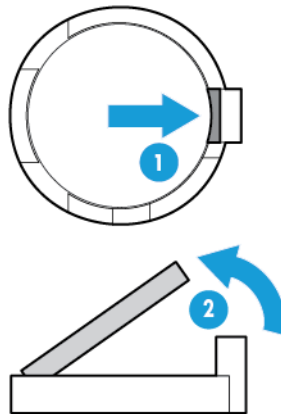

**IMPORTANT:** Replacing the system board battery resets the system ROM to its default configuration. After replacing the battery, reconfigure the system through RBSU.

To replace the component, reverse the removal procedure.

For more information about battery replacement or proper disposal, contact an authorized reseller or an authorized service provider.

---

# Troubleshooting

## Troubleshooting resources

The *HP ProLiant Gen9 Troubleshooting Guide, Volume I: Troubleshooting* provides procedures for resolving common problems and comprehensive courses of action for fault isolation and identification, issue resolution, and software maintenance on ProLiant servers and server blades. To view the guide, select a language:

- English ([http://www.hp.com/support/Gen9\\_TSG\\_en](http://www.hp.com/support/Gen9_TSG_en))
- French ([http://www.hp.com/support/Gen9\\_TSG\\_fr](http://www.hp.com/support/Gen9_TSG_fr))
- Spanish ([http://www.hp.com/support/Gen9\\_TSG\\_es](http://www.hp.com/support/Gen9_TSG_es))
- German ([http://www.hp.com/support/Gen9\\_TSG\\_de](http://www.hp.com/support/Gen9_TSG_de))
- Japanese ([http://www.hp.com/support/Gen9\\_TSG\\_ja](http://www.hp.com/support/Gen9_TSG_ja))
- Simplified Chinese ([http://www.hp.com/support/Gen9\\_TSG\\_zh\\_cn](http://www.hp.com/support/Gen9_TSG_zh_cn))

The *HP ProLiant Gen9 Troubleshooting Guide, Volume II: Error Messages* provides a list of error messages and information to assist with interpreting and resolving error messages on ProLiant servers and server blades. To view the guide, select a language:

- English ([http://www.hp.com/support/Gen9\\_EMG\\_en](http://www.hp.com/support/Gen9_EMG_en))
- French ([http://www.hp.com/support/Gen9\\_EMG\\_fr](http://www.hp.com/support/Gen9_EMG_fr))
- Spanish ([http://www.hp.com/support/Gen9\\_EMG\\_es](http://www.hp.com/support/Gen9_EMG_es))
- German ([http://www.hp.com/support/Gen9\\_EMG\\_de](http://www.hp.com/support/Gen9_EMG_de))
- Japanese ([http://www.hp.com/support/Gen9\\_EMG\\_ja](http://www.hp.com/support/Gen9_EMG_ja))
- Simplified Chinese ([http://www.hp.com/support/Gen9\\_EMG\\_zh\\_cn](http://www.hp.com/support/Gen9_EMG_zh_cn))



---

# Regulatory information

## Safety and regulatory compliance

For safety, environmental, and regulatory information, see *Safety and Compliance Information for Server, Storage, Power, Networking, and Rack Products*, available at the HP website (<http://www.hp.com/support/Safety-Compliance-EnterpriseProducts>).

## Belarus Kazakhstan Russia marking



### Manufacturer

Hewlett-Packard Company, Address: 3000 Hanover Street, Palo Alto, California 94304, U.S.

### Local representative information (Russian)

- HP Russia  
ЗАО «Хьюлетт-Паккард А.О.», 125171, Россия, г. Москва, Ленинградское шоссе, 16А, стр.3, тел./факс: +7 (495) 797 35 00, +7 (495) 287 89 05
- HP Belarus  
ИООО «Хьюлетт-Паккард Бел», 220030, Беларусь, г. Минск, ул. Интернациональная, 36-1, офис 722-723, тел.: +375 (17) 392 28 18, факс: +375 (17) 392 28 21
- HP Kazakhstan  
ТОО «Хьюлетт-Паккард (К)», 050040, Казахстан, г. Алматы, Бостандықский район, ул. Тимирязева, 28В, 1 этаж, тел./факс: +7 (727) 355 35 50, +7 (727) 355 35 51

### Local representative information (Kazakh)

ЖШС «Хьюлетт-Паккард (К)», Қазақстан, Алматы қ., Бостандық ауданы, Тимирязев к-сі, 28В, тел./факс: +7 (727) 355 35 50, +7 (727) 355 35 51

### Manufacturing date

The manufacturing date is defined by the serial number (HP serial number format for this product):

CCSYWWZZZZ

Valid date formats include the following:

- YWW, where Y indicates the year counting from within each new decade, with 2000 as the starting point. For example, 238: 2 for 2002 and 38 for the week of September 9. In addition, 2010 is indicated by 0, 2011 by 1, 2012 by 2, 2013 by 3, and so forth.
- YYWW, where YY indicates the year, using a base year of 2000. For example, 0238: 02 for 2002 and 38 for the week of September 9.

## Turkey RoHS material content declaration

Türkiye Cumhuriyeti: EEE Yönetmeliğine Uygundur

## Ukraine RoHS material content declaration

Обладнання відповідає вимогам Технічного регламенту щодо обмеження використання деяких небезпечних речовин в електричному та електронному обладнанні, затвердженого постановою Кабінету Міністрів України від 3 грудня 2008 № 1057

## Warranty information

HP ProLiant and X86 Servers and Options (<http://www.hp.com/support/ProLiantServers-Warranties>)

HP Enterprise Servers (<http://www.hp.com/support/EnterpriseServers-Warranties>)

HP Storage Products (<http://www.hp.com/support/Storage-Warranties>)

HP Networking Products (<http://www.hp.com/support/Networking-Warranties>)

---

# Electrostatic discharge

## Preventing electrostatic discharge

To prevent damaging the system, be aware of the precautions you need to follow when setting up the system or handling parts. A discharge of static electricity from a finger or other conductor may damage system boards or other static-sensitive devices. This type of damage may reduce the life expectancy of the device.

To prevent electrostatic damage:

- Avoid hand contact by transporting and storing products in static-safe containers.
- Keep electrostatic-sensitive parts in their containers until they arrive at static-free workstations.
- Place parts on a grounded surface before removing them from their containers.
- Avoid touching pins, leads, or circuitry.
- Always be properly grounded when touching a static-sensitive component or assembly.

## Grounding methods to prevent electrostatic discharge

Several methods are used for grounding. Use one or more of the following methods when handling or installing electrostatic-sensitive parts:

- Use a wrist strap connected by a ground cord to a grounded workstation or computer chassis. Wrist straps are flexible straps with a minimum of 1 megohm  $\pm 10$  percent resistance in the ground cords. To provide proper ground, wear the strap snug against the skin.
- Use heel straps, toe straps, or boot straps at standing workstations. Wear the straps on both feet when standing on conductive floors or dissipating floor mats.
- Use conductive field service tools.
- Use a portable field service kit with a folding static-dissipating work mat.

If you do not have any of the suggested equipment for proper grounding, have an authorized reseller install the part.

For more information on static electricity or assistance with product installation, contact an authorized reseller.

# Specifications

## Environmental specifications

Specification	Value
<b>Temperature range*</b>	—
Operating	10°C to 35°C (50°F to 95°F)
Nonoperating	-30°C to 60°C (-22°F to 140°F)
<b>Relative humidity (noncondensing)</b>	—
Operating	Minimum to be the higher (more moisture) of -12°C (10.4°F) dew point or 8% relative humidity Maximum to be 24°C (75.2°F) dew point or 90% relative humidity
Nonoperating	5% to 95% 38.7°C (101.7°F), maximum wet bulb temperature

\* All temperature ratings shown are for sea level. An altitude derating of 1.0°C per 304.8 m (1.8°F per 1000 ft) to 3048 m (10,000 ft) is applicable. No direct sunlight allowed. Maximum rate of change is 20°C per hour (36°F per hour). The upper limit and rate of change might be limited by the type and number of options installed.

For certain approved hardware configurations, the supported system inlet temperature range is extended:

- 5°C to 10°C (41°F to 50°F) and 35°C to 40°C (95°F to 104°F) at sea level with an altitude derating of 1.0°C per every 175 m (1.8°F per every 574 ft) above 900 m (2953 ft) to a maximum of 3048 m (10,000 ft).
- 40°C to 45°C (104°F to 113°F) at sea level with an altitude derating of 1.0°C per every 125 m (1.8°F per every 410 ft) above 900 m (2953 ft) to a maximum of 3048 m (10,000 ft).

The approved hardware configurations for this system are listed on the HP website (<http://www.hp.com/servers/ASHRAE>).

## Mechanical specifications

### HP Apollo r2200 Chassis (12 LFF)

Specifications	Value
<b>Dimensions</b>	
Height	8.73 cm (3.44 in)
Depth	86.33 cm (33.40 in)
Width	44.80 cm (17.64 in)
<b>Weight (with nodes removed)</b>	

Specifications	Value
Weight (maximum)	25.37 kg (55.94 lb)
Weight (minimum)	11.94 kg (26.37 lb)

#### HP Apollo r2600 Chassis (24 SFF)

Specifications	Value
<b>Dimensions</b>	
Height	8.73 cm (3.44 in)
Depth	82.27 cm (32.40 in)
Width	44.80 cm (17.64 in)
<b>Weight (with nodes removed)</b>	
Weight (maximum)	23.45 kg (51.70 lb)
Weight (minimum)	9.86 kg (21.74 lb)

#### HP ProLiant XL170r Gen9 Server Node (1U)

Specifications	Value
<b>Dimensions</b>	
Height	4.13 cm (1.63 in)
Depth	64.15 cm (25.26 in)
Width	17.95 cm (7.07 in)
<b>Weight</b>	
Weight (maximum)	1.73 kg (3.82)
Weight (minimum)	1.67 kg (3.69 lb)

#### HP ProLiant XL190r Gen9 Server Node (2U)

Specifications	Value
<b>Dimensions</b>	
Height	8.36 cm (3.30 in)
Depth	69.15 cm (27.23 in)
Width	17.95 cm (7.07 in)
<b>Weight</b>	
Weight (maximum)	6.47 kg (14.27)
Weight (minimum)	4.73 kg (10.43 lb)

## Power supply specifications

Depending on installed options, the node is configured with one of the following power supplies:

- HP 800W Flex Slot Titanium Hot Plug Power Supply Kit – 96% efficiency
- HP 800W Flex Slot Platinum Hot Plug Power Supply Kit – 94% efficiency
- HP 800W Flex Slot Universal Hot Plug Power Supply Kit – 94% efficiency
- HP 800W Flex Slot -48VDC Hot Plug Power Supply Kit – 94% efficiency

- HP 1400W Flex Slot Platinum Plus Hot Plug Power Supply Kit – 94% efficiency

For detailed power supply specifications, see the QuickSpecs on the HP website ([http://h18000.www1.hp.com/products/quickspecs/14209\\_div/14209\\_div.html](http://h18000.www1.hp.com/products/quickspecs/14209_div/14209_div.html)).

## Hot-plug power supply calculations

For hot-plug power supply specifications and calculators to determine electrical and heat loading for the server, see the HP website (<http://www.hp.com/go/hppoweradvisor>).

---

# Support and other resources

## Before you contact HP

Be sure to have the following information available before you call HP:

- Active Health System log (HP ProLiant Gen8 or later products)  
Download and have available an Active Health System log for 7 days before the failure was detected. For more information, see the *HP iLO 4 User Guide* or *HP Intelligent Provisioning User Guide* on the HP website (<http://www.hp.com/go/ilo/docs>).
- Onboard Administrator SHOW ALL report (for HP BladeSystem products only)  
For more information on obtaining the Onboard Administrator SHOW ALL report, see the HP website (<http://www.hp.com/go/OAlog>).
- Technical support registration number (if applicable)
- Product serial number
- Product model name and number
- Product identification number
- Applicable error messages
- Add-on boards or hardware
- Third-party hardware or software
- Operating system type and revision level

## HP contact information

For United States and worldwide contact information, see the Contact HP website (<http://www.hp.com/go/assistance>).

In the United States:

- To contact HP by phone, call 1-800-334-5144. For continuous quality improvement, calls may be recorded or monitored.
- If you have purchased a Care Pack (service upgrade), see the Support & Drivers website (<http://www8.hp.com/us/en/support-drivers.html>). If the problem cannot be resolved at the website, call 1-800-633-3600. For more information about Care Packs, see the HP website (<http://pro-aq-sama.houston.hp.com/services/cache/10950-0-0-225-121.html>).

---

# Acronyms and abbreviations

## ABEND

abnormal end

## ACU

Array Configuration Utility

## ADM

Advanced Data Mirroring

## AMP

Advanced Memory Protection

## ASHRAE

American Society of Heating, Refrigerating and Air-Conditioning Engineers

## ASR

Automatic Server Recovery

## CSA

Canadian Standards Association

## CSR

Customer Self Repair

## DDR

double data rate

## DPC

DIMMs per channel

## EAC

EuroAsian Economic Commission

## FBWC

flash-backed write cache



## GPU

graphics processing unit

## HP APM

HP Advanced Power Manager

## HP SIM

HP Systems Insight Manager

## HP SSA

HP Smart Storage Administrator

## HP SUM

HP Smart Update Manager

## IEC

International Electrotechnical Commission

## iLO

Integrated Lights-Out

## IML

Integrated Management Log

## ISO

International Organization for Standardization

## LFF

large form factor

## LOM

LAN on Motherboard

## LRDIMM

load reduced dual in-line memory module

## NMI

nonmaskable interrupt

## NVRAM

nonvolatile memory

## OA

Onboard Administrator

## PCIe

Peripheral Component Interconnect Express

## PDU

power distribution unit

## POST

Power-On Self Test

## RBSU

ROM-Based Setup Utility

## RCM

Rack control management

## RDIMM

registered dual in-line memory module

## RDP

Remote Desktop Protocol

## RPS

redundant power supply

## SAS

serial attached SCSI

## SATA

serial ATA

## SFF

small form factor

## SIM

Systems Insight Manager

## SPP

HP Service Pack for ProLiant

## SUV

serial, USB, video

## TPM

Trusted Platform Module

## UEFI

Unified Extensible Firmware Interface

## UID

unit identification

## USB

universal serial bus

## VCA

Version Control Agent

## VCRM

Version Control Repository Manager

## VM

Virtual Machine

---

# Documentation feedback

HP is committed to providing documentation that meets your needs. To help us improve the documentation, send any errors, suggestions, or comments to Documentation Feedback (<mailto:docsfeedback@hp.com>). Include the document title and part number, version number, or the URL when submitting your feedback.

---

# Index

## A

- access panel 36
- Active Health System 143, 144
- ACU (Array Configuration Utility) 152
- Advanced ECC memory 75, 76
- Advanced ECC support 75
- airflow requirements 56
- Array Configuration Utility (ACU) 152
- ASR (Automatic Server Recovery) 152
- authorized reseller 163, 167
- Automatic Server Recovery (ASR) 152

## B

- battery replacement notice 161
- Belarus Kazakhstan Russia marking 161
- BIOS upgrade 143
- boot options 149, 151
- BSMI notice 161
- buttons 9
- buttons, front panel 9

## C

- Cable guard 133
- cables 133
- cabling 133
- cabling, front LED 133
- cache module 140
- Care Pack 54, 146, 157, 167
- cautions 163
- Change Control 149, 152, 157
- chassis components 9, 10, 11, 12, 16
- components 9
- components, identification 9, 10, 11, 12, 13, 14, 16, 19, 27
- configuration of system 143
- connectors 9
- contacting HP 167
- crash dump analysis 18
- customer self repair (CSR) 167

## D

- diagnosing problems 160
- diagnostic tools 143, 147, 151, 152
- diagnostics utility 147
- DIMM installation guidelines 74
- DIMM slot locations 19
- DIMMs, single- dual-, and quad-rank 74
- documentation 172
- documentation feedback 172
- drive numbering 19
- drivers 155

## E

- electrical grounding requirements 56
- electrostatic discharge 163
- environmental requirements 55
- Erase Utility 143, 147

## F

- FBWC module 97
- firmware 153, 156
- front panel components 9
- front panel LEDs 10

## G

- grounding methods 163
- grounding requirements 56, 163

## H

- hardware options 64
- hardware options installation 64
- health driver 152
- heatsink 123
- HP Advanced Power Manager (HP APM) 62
- HP Care Pack Services 54, 157
- HP contact information 167
- HP iLO 143
- HP Insight Diagnostics 147
- HP Insight Online 143, 146
- HP Insight Remote Support software 146, 157

HP RESTful API 145, 151  
HP Service Pack for ProLiant 143, 147, 148  
HP Smart Storage Battery 99  
HP Smart Update Manager overview 143, 148  
HP SSA (HP Smart Storage Administrator) 143, 152

## I

iLO (Integrated Lights-Out) 143, 144, 145  
IML (Integrated Management Log) 143, 145  
Insight Diagnostics 147, 153  
installation services 54  
installation, server options 64  
installing hardware 64  
installing operating system 62  
Integrated Lights-Out (iLO) 143, 145  
Integrated Management Log (IML) 145  
Intelligent Provisioning 63, 143, 146, 147, 149  
internal USB connector 152

## L

LEDs, drive 22  
LEDs, power supply 16  
LEDs, troubleshooting 160

## M

M.2 SATA SSD enablement board 121  
memory 74, 76  
memory configurations 76  
memory subsystem architecture 74  
memory, Advanced ECC 75  
memory, configuring 75, 76  
memory, online spare 76

## N

NIC connectors 13  
NMI functionality 18  
NMI header 18

## O

online spare memory 76, 77  
operating system installation 157  
operating systems 156, 157  
operations 31  
optimum environment 55  
options installation 64

## P

PCI riser cage 84  
phone numbers 167  
population guidelines, Advanced ECC 76  
power requirements 56, 166  
power supply 166  
powering down 31  
processor 123  
Product ID 151

## Q

QuickSpecs 143

## R

Rack Control Management (RCM) module 67  
rack installation 54  
rack warnings 57  
rear panel components 11, 13  
rear panel LEDs 12, 14  
redundant ROM 153  
registering the server 63  
regulatory compliance notices 161  
removing node from chassis 32  
requirements, power 56, 166  
requirements, temperature 56  
ROM-Based Setup Utility (RBSU) 149  
ROMPaq utility 153

## S

safety considerations 153, 161, 163  
safety information 153, 161  
scripted installation 148  
scripting toolkit 143, 148  
security bezel, installing 64  
security bezel, removing 35  
serial number 151  
server features and options 64  
Smart Update Manager 143, 148  
software 63, 156, 157  
specifications, environmental 164  
support 167  
support and other resources 167  
supported operating systems 156, 157  
system battery 161, 163  
system board components 16  
System Erase Utility 147

## **T**

- technical support 157, 167
- telephone numbers 167
- temperature requirements 56, 164
- TPM (Trusted Platform Module) 129, 131
- troubleshooting 160
- troubleshooting resources 160
- Trusted Platform Module (TPM) 129, 131

## **U**

- updating the system ROM 153, 154, 155
- USB support 152
- utilities 143, 149, 152
- utilities, deployment 143, 148

## **V**

- ventilation 55
- Virtualization option 157

## **W**

- warnings 57

## Free Manuals Download Website

<http://myh66.com>

<http://usermanuals.us>

<http://www.somanuals.com>

<http://www.4manuals.cc>

<http://www.manual-lib.com>

<http://www.404manual.com>

<http://www.luxmanual.com>

<http://aubethermostatmanual.com>

Golf course search by state

<http://golfingnear.com>

Email search by domain

<http://emailbydomain.com>

Auto manuals search

<http://auto.somanuals.com>

TV manuals search

<http://tv.somanuals.com>