



**OWNER'S MANUAL
& INSTALLATION
INSTRUCTIONS**

SunSetter

**VISTA[®] *and*
Motorized Awnings**

WARNING:

Failure to follow these
instructions could result in
PERSONAL INJURY!

Congratulations! You have just purchased America's # 1 Retractable Awning. The SunSetter lateral arm awning will provide you and your family with many years of enjoyment on your deck or patio.

Before you begin installation, take a moment to familiarize yourself with the awning and your Owner's Manual. Please check to insure all of the parts listed on page 4 have been included with your awning and that you have the correct size, color and model awning.

Installation of your Awning

Note: Your awning has been shipped to you fully assembled but, it is important to follow this instruction manual to securely fasten the mounting brackets to your home and install the awning. Please read these instructions completely before installing your SunSetter awning.

Left and Right references are as you are facing the house. You have been provided with the proper fasteners for mounting to your wall surface either wood lag screws or masonry bolts.

For the greatest enjoyment of your lateral arm awning, please mount as high on your wall as possible, with a recommended mounting height of 9'. If your awning is a motorized model, your electrical cord will allow you 12' to reach your GFI outlet and you will find your remote attached to the cord. If you will be installing a protective cover, do so after Step 15 on page 9. If you are installing on a soffit, see Appendix C on page 16.

Operation of your Awning

Your SunSetter Awning, once installed, has the ability to be opened partially or to its full projection to suit your deck or patio design. The pitch of your awning may be easily adjusted, up or down, from the factory setting based upon your actual mounting height. Please see Appendix A on page 13, if you would like to make this adjustment.

Please retain your Owner's Manual and Installation Instructions for future reference regarding operation, care and maintenance, troubleshooting, customer service and warranty information.

Customer Support

Our technical experts are available from 8am - 10pm EST daily via email at contactus@sunsetter.com or call us at 800-670-7071 should you require assistance. We also invite you to visit the Owner's Corner at www.sunsetter.com/ownerscorner for additional information on your awning and other products.

We know that you will be delighted with your SunSetter awning and will experience many years of added enjoyment on your deck or patio.

Awning Installation Instructions

WARNING: Failure to follow these instructions could result in PERSONAL INJURY!

WARNING: Do not remove the plastic safety sleeves from the lateral arms until instructed to do so.

Before Starting

1. Before beginning, please familiarize yourself with the components of the awning as shown in Figure 1, and the supplied fasteners/parts shown on pages 4 & 5. Find the mounting brackets (wall or soffit) in the package (they are separated from the awning itself). **If you are mounting your awning on a soffit, please go to Appendix C on page 16 for this type of installation.**

Note: This figure shows awning with motor installed on the right as you face the house.

Note: Number of brackets supplied with awning will vary depending on awning size, see page 3.

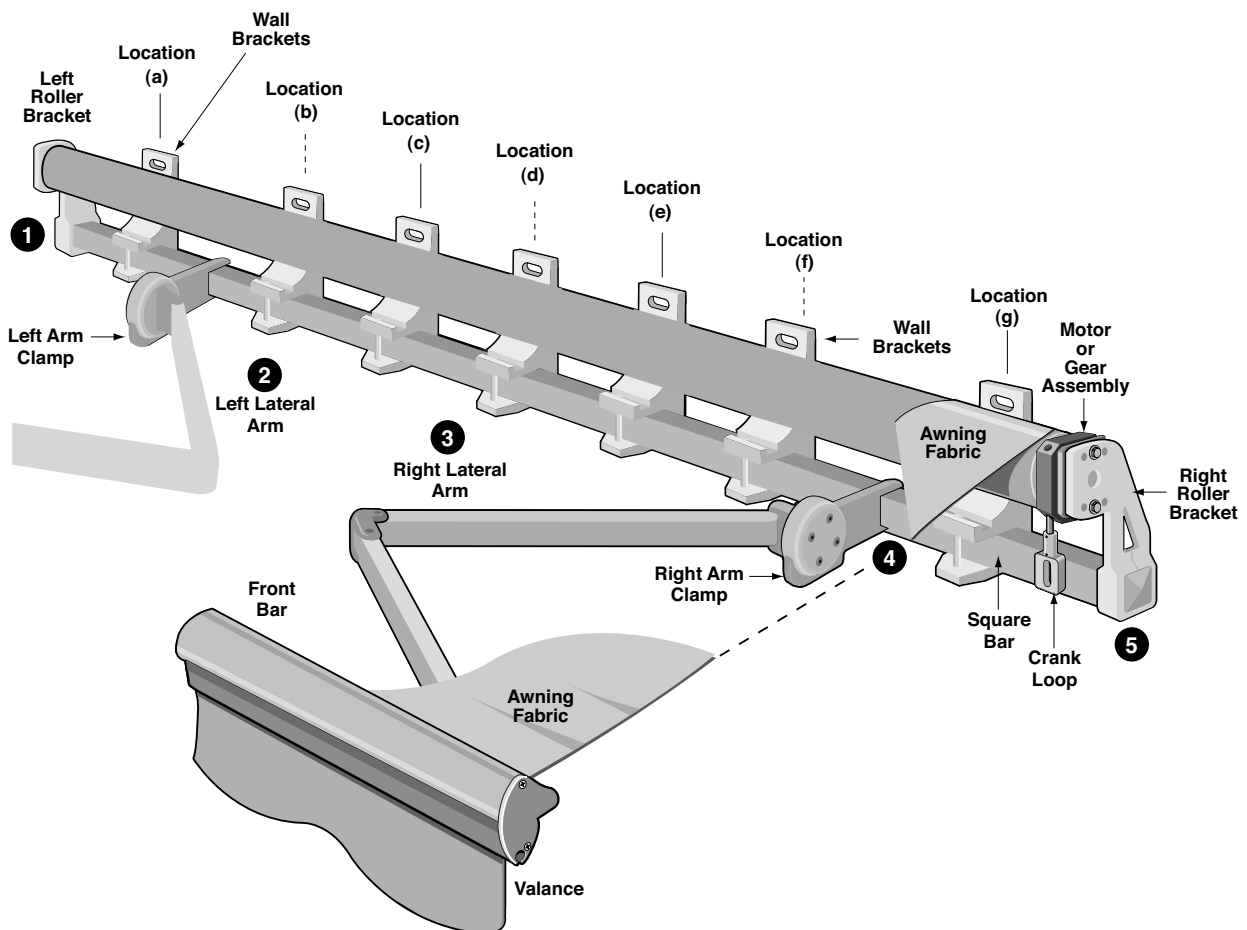

Figure 1

Figure 1a
Bracket locations for 10'-13' wide awnings.

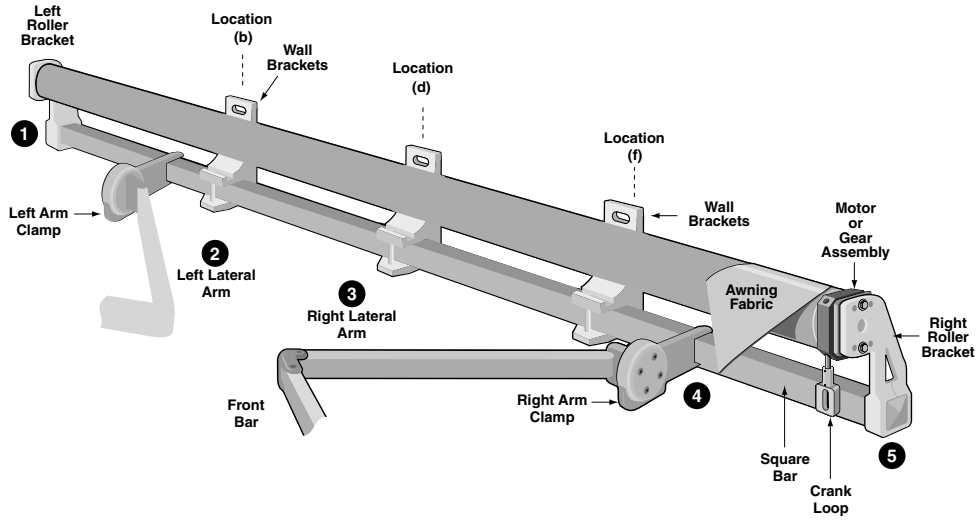

Figure 1b
Bracket locations for 14'-16' wide awnings.

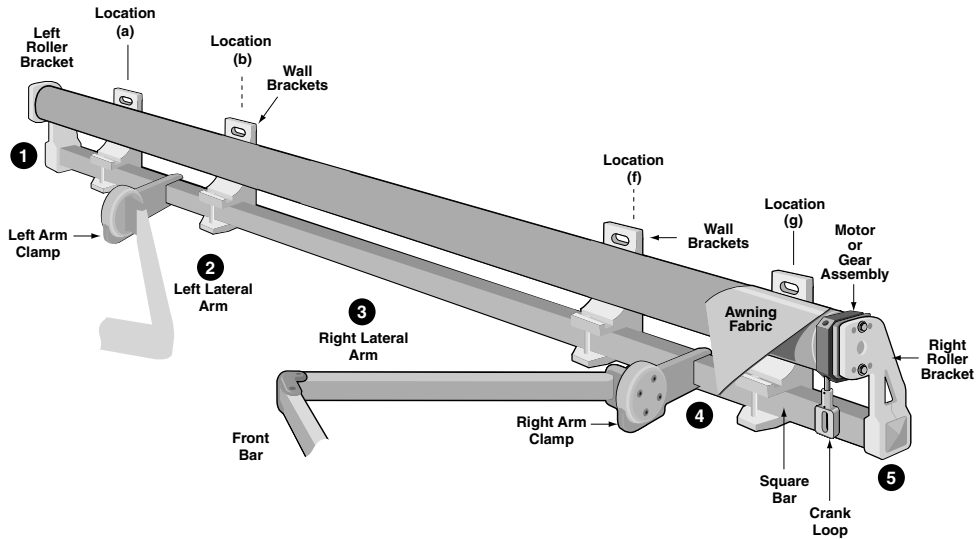
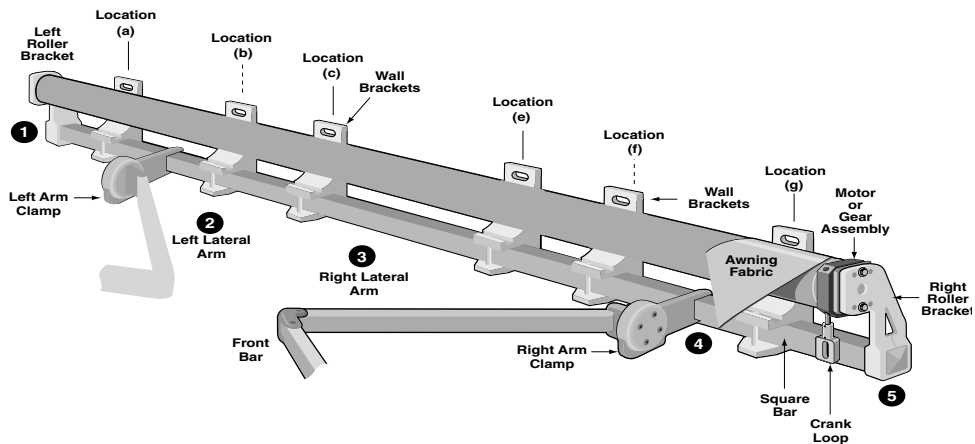
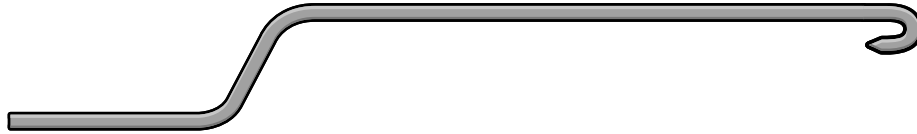

Figure 1c
Bracket locations for 17' & 18' wide awnings.



Supplied Fasteners / Parts List



Crank Wand
Qty 1

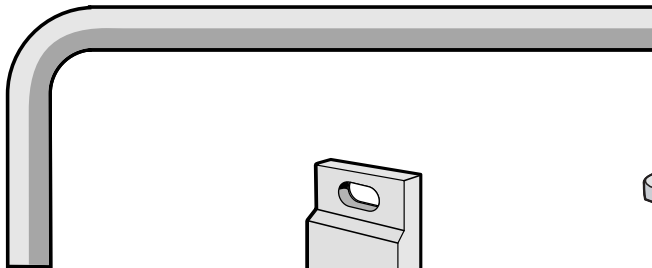

6 mm Allen Wrench
Qty 1

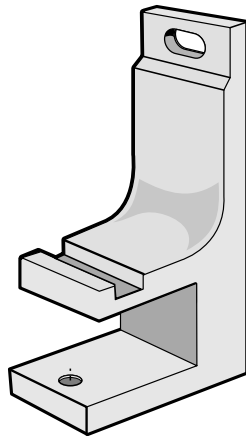

Wall Bracket
10' - 13' : Qty 3
14' - 16' : Qty 4
17' - 18' : Qty 6

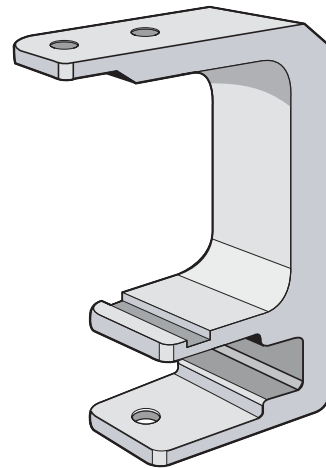

Soffit Bracket
10' - 13' : Qty 3
14' - 16' : Qty 4
17' - 18' : Qty 6

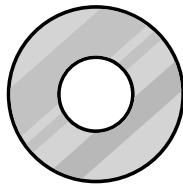

3/8" Flat Washer
(12' & 13' : Qty 6 ~ 14', 15' & 16' : Qty 8
17' & 18' : Qty 12)

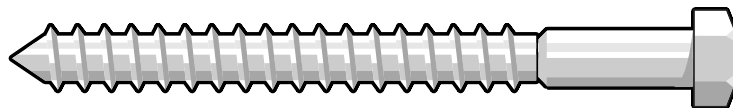

3/8" x 4" Lag Screw
(12' & 13' : Qty 6 ~ 14', 15' & 16' : Qty 8
17' & 18' : Qty 12)

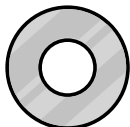

5/16" Flat Washer



5/16" Retaining Nut



5/16" x 2-3/4" Retaining Hex Bolt

(10' - 13' : Qty 3 ~ 14' - 16' : Qty 4 ~ 17' - 18' : Qty 6)

Additional Parts List - Motorized Models Only

Motor Installed
on Left Side

Motor Installed
on Right Side

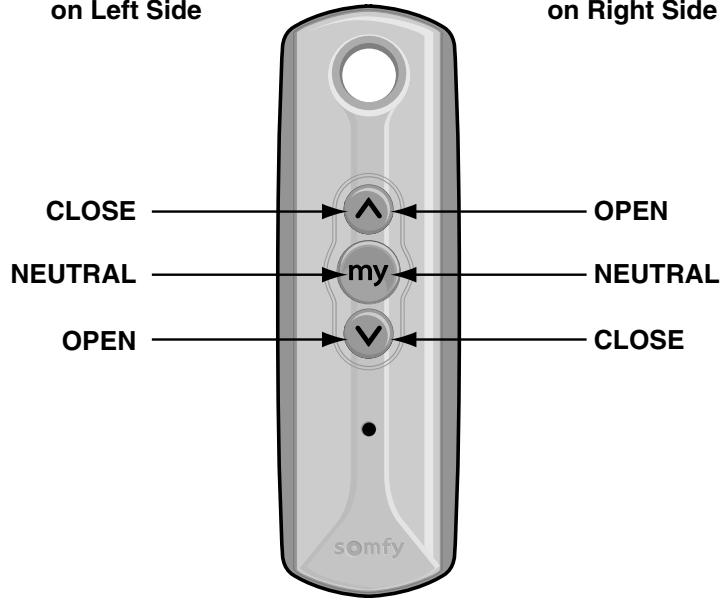

Remote Transmitter
Qty 1

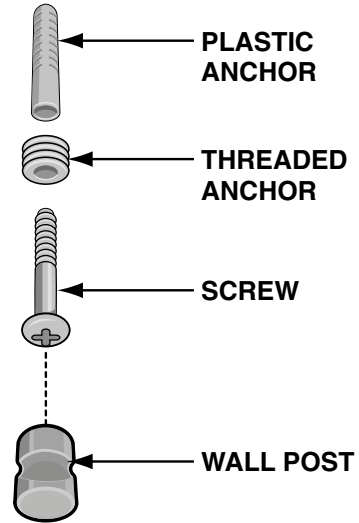

Wall Mount for
Remote Transmitter
Qty 1

Note: Remote Transmitter is packaged in a clear bubble pack and taped to the Motor Power Cord.

Optional Parts List - Masonry, Brick or Concrete Installations



3/8" x 6" Masonry Drill Bit
(For Masonry Walls)
Qty 1

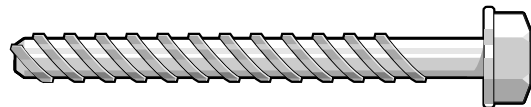

3/8" x 4" Masonry Bolt
(For Masonry Walls)
(10' - 13' : Qty 6 ~ 14', 15' & 16' : Qty 8 ~ 17' & 18' : Qty 12)

Tools Required

In your package you will find the following tools: 6mm Allen wrench.

For any type of wall construction you will need an assistant, measuring tape, two step-ladders, 9/16" socket, chalk line (or string), Phillips screwdriver, pencil, level, electric drill and a 1/2" or 13mm wrench and a stud finder.

If you have a wood frame construction with wood, vinyl, stucco or aluminum siding, you will need in addition to the above: 1/8" and 1/4" drill bits.

If you have masonry construction or brick walls, you will need a 1/4" masonry drill bit.

Mounting Height

The mounting height is defined as one inch above the highest part of the wall bracket from the deck/patio floor – see figure 2.

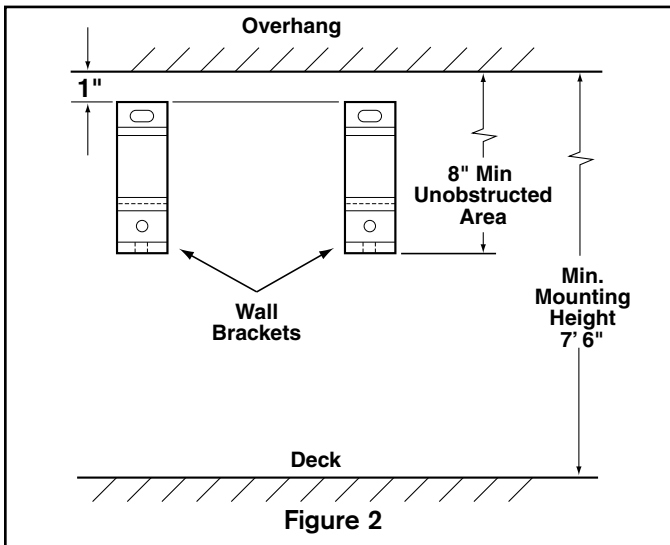

Your awning's pitch (angle) is pre-set at the factory with a drop of 29 inches from the top of the wall brackets to the lowest point at the front bar of the awning. For example: If you mount the awning on the wall at 9 ft. from the deck/patio, the lowest point at the front bar of the awning at full projection will be 6 foot 6 inches – see figure 3. The awning pitch (angle) can be adjusted after installing the awning.

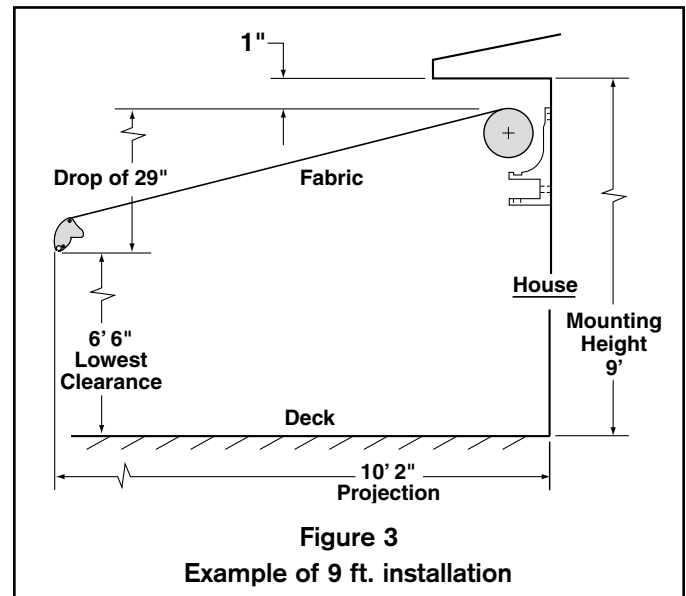

Note: When making the decision on the mounting height, remember that the awning requires 8 inches of unobstructed area along the whole length of the awning to fit the mounting brackets on your wall – see figure 2.

To assure head clearance at the front of the awning, we recommend to install the awning above 7 foot 6 inches from the deck/patio, with an optimal mounting height of 9 foot or above.

With the above in mind, decide on the mounting height for your application. If you need help, call our toll-free hot line at 1-800-670-7071.

2. Measure up from the deck/patio floor on one side and make a mark at your desired mounting height (must be at least 7' 6"). Make a second mark 8 inches below the first mark. The space between these marks must be clear of obstructions, (light fixtures, etc) all along the length of the wall. Using a chalk line or a string, snap a level line on the lower mark for the length of the awning. The bottom of the wall brackets will rest on this lower line.

NOTE: For ease of mounting the awning into the brackets, it is very important that the line will be straight and level.

Locating the brackets

CAUTION: PROPER LOCATION OF THE BRACKETS IS THE MOST IMPORTANT ASPECT OF THE AWNING MOUNTING. IT IS CRITICAL THAT YOU FASTEN THE MOUNTING BRACKETS TO STUDS, JOISTS, HEADERS OR OTHER MAJOR STRUCTURAL MEMBERS.

Even a moderate wind exerts great force on the awning and mounting brackets. This is why it is most important that all the brackets will be fastened properly and securely. Proper location will also make it easier to insert the pre-assembled awning into the supporting brackets.

WARNING: FAILURE TO SECURELY FASTEN THE BRACKETS TO THE WALL COULD RESULT IN THE COLLAPSE OF THE AWNING AND CAUSE PERSONAL INJURY.

NOTE: Mount brackets only in the locations recommended for your awning size. (See Fig. 1 on page 3)

NOTE: You will need to use all brackets supplied for secure mounting.

For 10 ft to 13 ft wide awnings, we recommend to install three brackets supplied at the locations (b) (d) and (f). (See Fig.1a) For 14 ft, 15 ft and 16 ft wide awnings, we recommend to install four brackets supplied at the locations (a) (b) (f) and (g) (See Fig. 1b). For 17 ft and 18 ft wide awnings, use six brackets supplied at locations (a) (b) (c) (e) (f) and (g). See Fig. 1c.

Location (a) -- Between the left end of the awning and the left arm, on the stud nearest to the left end.

Location (b) -- Between the two arms, on the nearest stud to the left arm.

Location (c) -- On the nearest stud midway between the middle point of the awning and the left arm.

Location (d) -- The nearest stud to the middle point of the awning. (Size 10' - 13' only)

Location (e) -- On the nearest stud midway between the middle point of the awning and the right arm.

Location (f) -- Between the two arms, on the nearest stud to the right arm.

Location (g) -- Between the right end of the awning and the right arm, on the stud nearest to the right end.

For wall mount on wood frame walls, continue with step 3.

For wall mount on masonry, brick or concrete walls, proceed to step 9.

Installing the brackets on wood frame walls w/wood, vinyl, stucco or aluminum siding

3. On the chalk line you have marked on the house, mark the left and the right ends of the awning (points 1 and 5 in figure 1). With the exception of the 10' awning, which measures 123" left to right, all other awnings measure exactly like their defined size. (For example, a 12ft awning measures 144" from left to right). Using the chart below, mark on the chalk line the middle point and the points where the left and right arm clamps will be located (points 2, 3 and 4 in figure 1 respectively).

Note: The brackets cannot be installed in the area where the arm clamps are located.

Size	Left arm Clamp	Middle point	Right arm Clamp
10ft	1-1/4" from left end	61"	1-1/4" from right end
11ft	7" from left end	66"	7" from right end
12ft	8" from left end	72"	8" from right end
13ft	14" from left end	78"	14" from right end
14ft	20" from left end	84"	20" from right end
15ft	26" from left end	90"	26" from right end
16ft	32" from left end	96"	32" from right end
17ft	38" from left end	102"	38" from right end
18ft	44" from left end	108"	44" from right end

4. YOU MUST NOW LOCATE THE STUDS, JOISTS OR HEADERS IN THE AREA IN WHICH THE BRACKETS MUST BE INSTALLED AS EXPLAINED EARLIER IN "LOCATING THE BRACKETS". If your awning is going on a wall that has a window or a door use these steps to locate the studs inside your home and transfer those measurements to the outside. Get a roll of duct tape or a similar tape. From inside your home on the wall that your awning will be installed on place a piece (about 6" strip) of the duct tape vertically on the window pane. Now using a stud finder (be sure to read the stud finder instructions before usage) locate a stud on the same inside wall, and mark the center of the stud. Measure from the tape or door to the center of the stud, and write the measurement down. Continue to locate the additional studs and record those measurements. On the outside wall, using the inside measurements, measure from the tape or door to the location of the center of the studs. Mark the center of each stud on which a bracket will be installed with a 7" vertical line.

Note: For an attractive finished appearance, you can use wood spacers or shims underneath each bracket to make a flat surface - see figure 4. Shims are not supplied with your awning.

Installing the brackets on masonry, brick or concrete walls

WARNING: SOME BRICK WALLS MIGHT NOT BE STRONG ENOUGH TO SAFELY SUPPORT AN AWNING. WE SUGGEST TO CONSULT A LOCAL HANDYMAN OR CONTRACTOR FOR PROPER MOUNTING. WARNING: FAILURE TO SECURELY FASTEN THE BRACKETS TO THE WALL OR FAILURE OF THE WALL TO SUPPORT AN AWNING COULD RESULT IN THE COLLAPSE OF THE AWNING AND CAUSE PERSONAL INJURY.

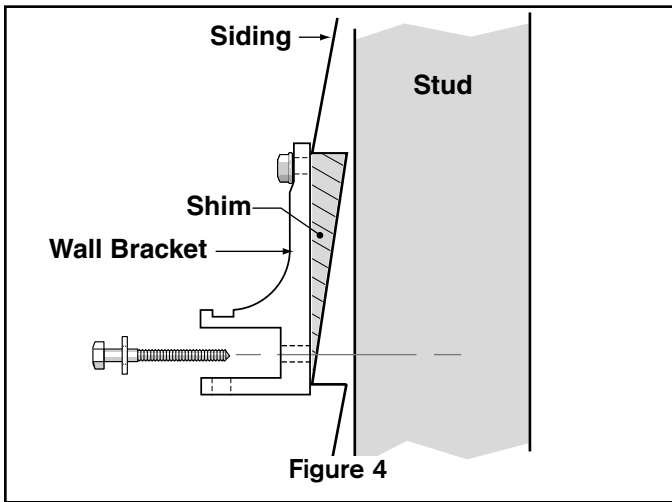

Figure 4

5. Position the bracket on the wall (or on the shim), centered over the vertical line, with the bottom of the bracket even with the lower horizontal chalk line. Using a level, plumb the bracket vertically, then mark the top and bottom holes-- see figure 5.

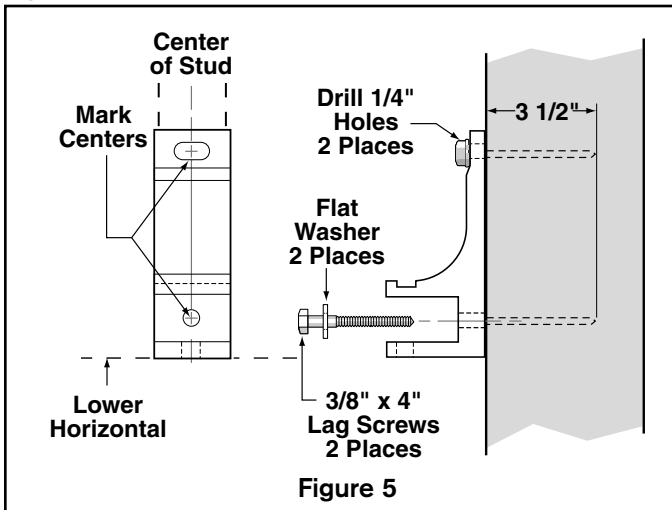

Figure 5

6. Remove the bracket and drill the top hole through the siding block and about 3 1/2" into the stud or joist, using a 1/4" drill bit. This will prevent the framing from splitting while installing the lag screws. Make sure the bottom hole is plumbed with the top hole, then drill the bottom hole.

7. Using a 9/16" socket, install the bracket with the two 3/8" x 4" long lag screws. Use the flat washer provided under the head of the screw. While tightening the lag screws, keep the bracket plumb (use level if needed). Do not overtighten the lag screws; doing so may split the wood framing or weaken the screw -- see figure 5.

8. Repeat for all brackets.

Proceed to step 15.

9. On the chalk line you have marked on the house, mark the left and the right ends of the awning. With the exception of the 10' awning, which measures 123" left to right, all other awnings measure exactly like their defined size. (For example, a 12ft awning measures 144" from left to right). Using the following chart, mark on the wall the location of the brackets and draw a 7" vertical line at each location.

Size	Loc.(a)	Loc.(b)	Loc.(c)	Loc.(d)	Loc.(e)	Loc.(f)	Loc.(g)
10ft	N/A	5" from end	N/A	61"	N/A	5" from end	N/A
11ft	N/A	10" from end	N/A	66"	N/A	10" from end	N/A
12ft	N/A	14" from end	N/A	72"	N/A	14" from end	N/A
13ft	N/A	20" from end	N/A	78"	N/A	20" from end	N/A
14ft	5" from end	26" from end	N/A	N/A	N/A	26" from end	5" from end
15ft	5" from end	32" from end	N/A	N/A	N/A	32" from end	5" from end
16ft	5" from end	38" from end	N/A	N/A	N/A	38" from end	5" from end
17ft	5" from end	44" from end	70" from end	N/A	70" from end	44" from end	5" from end
18ft	5" from end	50" from end	76" from end	N/A	76" from end	50" from end	5" from end

10. Position the bracket on the wall, centered over the vertical line, with the bottom of the bracket even with the lower horizontal chalk line. Using a level, plumb the bracket vertically, then mark the two holes -- see figure 7.

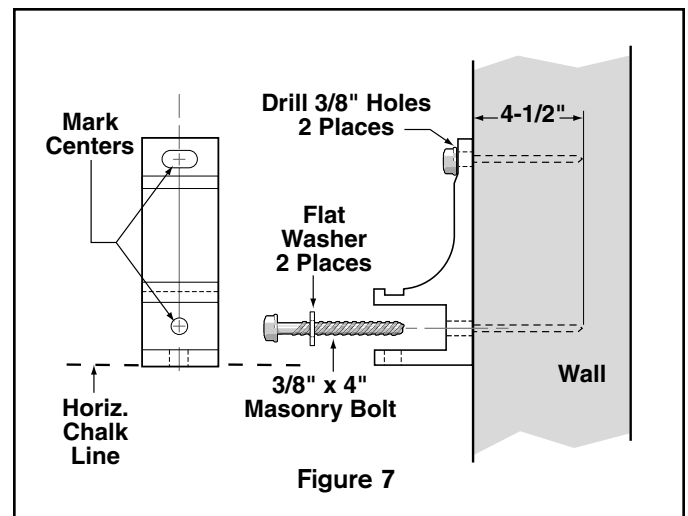
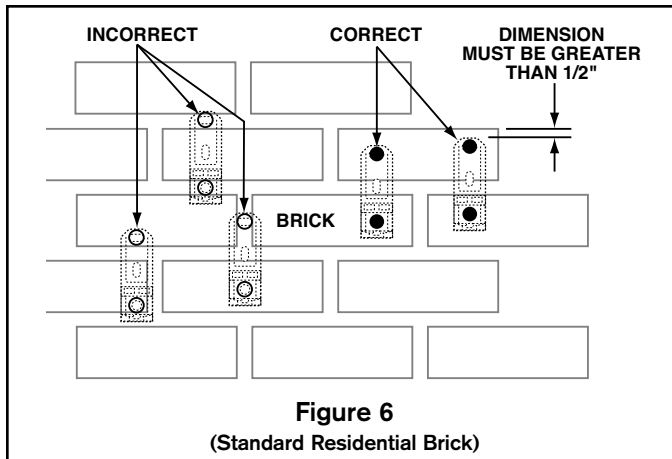

Figure 7

Securing the awning into the brackets

CAUTION: The masonry fasteners that are supplied with this awning ARE NOT designed for use in the joint between two bricks. They are ONLY to be installed within the main body of a brick, not within 1/2" of an outer edge of the brick (see figure 6). The fasteners are also not suitable for hollow cinder-block type construction or wall surfaces that have deteriorated. Consult a local hardware store for fasteners that fit this type of application. Do not use the supplied masonry fasteners on a Stucco wall.



11. Remove the bracket and drill a 1/4" pilot hole using a masonry drill bit, about 3" deep for the top hole. Make sure the bottom hole is plumbed with the top hole, then drill the bottom hole.

12. Using the 3/8" masonry bit supplied, drill both holes 4-1/2" deep. Do not allow the holes to become tapered or oversized while drilling to this final size. **CAUTION:** You must drill these holes in the two specified steps. If you do not follow these steps, the size of the hole can become too large and the bolts will not hold properly.

13. Place a flat washer under the head of the masonry bolt and screw the bolt into the hole using a 9/16" socket - see figure 7. Repeat for other bolt. While tightening the bolts, make sure to keep the bracket plumb (use a level if needed). Do not overtighten the bolts.

WARNING: YOU MUST BE SURE THE MASONRY BOLTS ARE TIGHT IN THE HOLES. IF NOT, REMOVE THEM AND CONSULT A LOCAL HARDWARE STORE FOR FASTENERS THAT FIT YOUR APPLICATION.

14. Repeat for all brackets.

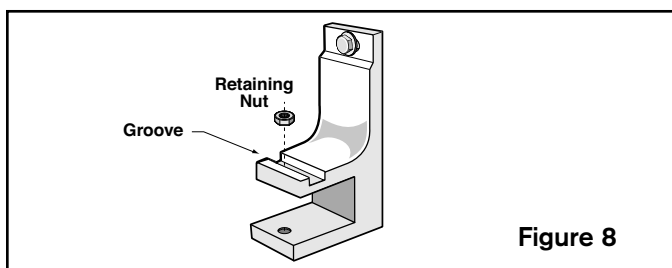

15. Carefully remove all packaging material from the awning. **DO NOT REMOVE THE PLASTIC SAFETY SLEEVES FROM THE ARMS.** -see Figure 10.

Note: If you ordered the Awning Protective cover, it is easier to install the fasteners for the cover before securing the awning into the brackets. Please follow the instructions included with the protective cover and then resume with step 16.

16. Separate the wand from the awning.

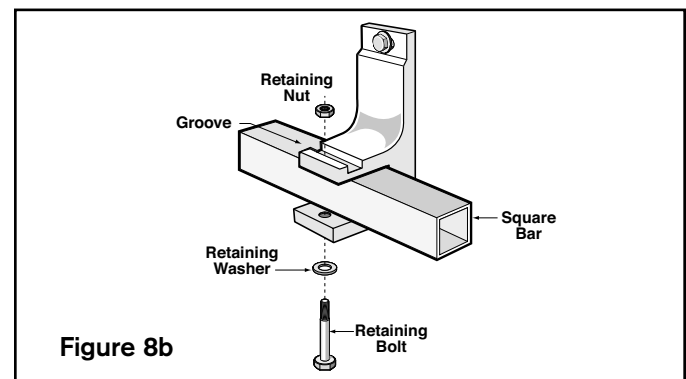
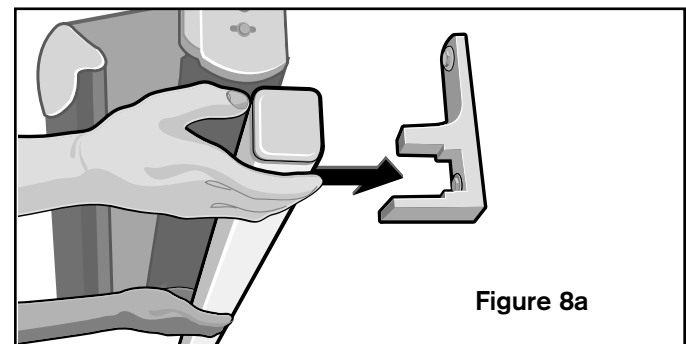

17. **All Models** - Insert the retaining nut into the special groove in each bracket -- see figure 8.

18. With proper help, lift the awning (**with fabric/roller bar above the square bar**) into the brackets and position so the ends line up with end points marked on the wall - see fig. 8a. Use the following weight chart to decide how much help you need.

Size	Weight Vista	Weight Motorized
10ft	78 lbs	84 lbs
11ft	83 lbs	89 lbs
12ft	90 lbs	96 lbs
13ft	95 lbs	101 lbs
14ft	100 lbs	106 lbs
15ft	105 lbs	111 lbs
16ft	110 lbs	116 lbs
17ft	115 lbs	121 lbs
18ft	120 lbs	126 lbs

19. Push the square bar into the brackets and secure with a retaining bolt in each bracket. Be sure to insert the bolt from the bottom of the bracket up. You might need to apply pressure on the square bar to permit insertion-- see Figure 8b.

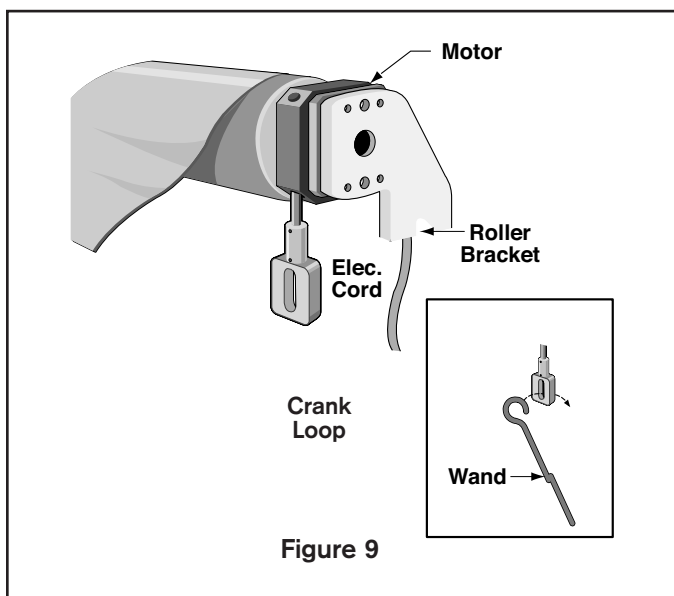

Figure 9

CAUTION: Do not permit the hand-held remote transmitter to get wet as this can affect its proper operation. It is recommended to install the wall holder inside the house.

Note: During an electrical outage, you can open or close your awning using the crank wand supplied. Just insert the wand into the crank loop and turn – see figure 9.

Test for Proper Operation

Note: The open and close stop limits on the awning motor were set and tested at the factory prior to shipment.

On occasion, these limits will lose the factory setting during shipping.

Test the operation of your awning by using the open and close buttons on your remote control. The awning should open to its full projection and the arms will still be bent but locked at the elbow (**this is normal**). The awning should close to about 1/2" inch between the Front Bar and the round side of the Arm Clamp (see figures 14a and 15 in Appendix B of your installation manual).

Checking Your Awning for Proper Operation.

NOTE: For Motorized Awnings - Do not plug the power cord into the outdoor outlet yet.

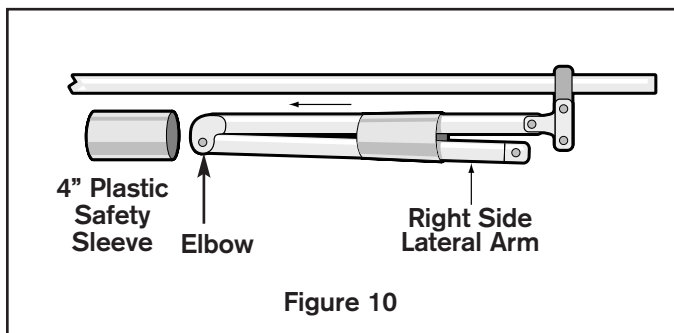

Figure 10

20. Remove the plastic safety sleeves from the arms - see figure 10.

Motorized Awnings continue with step 21.

For Vista Awnings proceed to step 23.

21. Plug the electric cord into your outdoor ground fault receptacle.

22. We've also supplied a wall holder for the remote transmitter - see figure on page 5. Simply position the wall post at the desired location, mark the hole location and secure with the supplied hardware, if needed.

If your awning fails to open to its full projection or does not appear to open and close properly, please follow the steps in Appendix B to restore the Open/Close Stop Limits.

Are you happy with the height and level of the Front Bar? If yes, Great! Your installation is now complete. Enjoy your new SunSetter awning.

23. Using the crank wand, open your awning to its full projection. The arms will still be bent but locked at the elbow. **This is normal.** They will never straighten out completely. Are you happy with the height and level of the front bar? If yes, Great!! Enjoy your new SunSetter awning.

If No, and you would like to change the pitch (angle) of your awning- refer to Appendix A on page 13.

GENERAL CARE AND MAINTENANCE OF YOUR SUNSETTER AWNING

CAUTION: Prior to operating the awning, be sure that no objects or persons can come in contact with it as it opens and closes. Keep children away from any moving parts of the awning as it operates.

CAUTION: Never attempt to hang items from any part of the awning, except those accessories that are supplied by the manufacturer.

WARNING: NEVER ATTEMPT TO REPAIR OR DISASSEMBLE ANY PART OF THE AWNING WITHOUT FOLLOWING REPLACEMENT PART PROCEDURES SUPPLIED BY THE MANUFACTURER. TRYING TO DO SO WITHOUT PROPER INSTRUCTIONS COULD RESULT IN PERSONAL INJURY.

CAUTION: Damage to the awning fabric, arms and mechanism caused by water pooling or windy conditions are not covered by the manufacturer's warranty. **Always retract your awning during periods of heavy rain and snow. Never leave your awning extended out and unattended when there are heavy winds.**

WARNING: RAIN WATER POOLING ON THE FABRIC COULD RESULT IN THE COLLAPSE OF THE AWNING AND CAUSE PERSONAL INJURY. YOU MUST ROLL-UP YOUR AWNING WHEN WATER STARTS POOLING ON THE FABRIC.

NOTE: It is normal for the fabric to form waves or wrinkles at the hemmed edges as the awning rolls up. This is because the fabric layer is double only along the edges. It is also possible for the awning fabric to slightly sag as a result of its own weight, this is normal.

PROTECTING THE SUNSETTER FABRIC FROM MILDEW

If it is necessary to roll the awning up wet, be sure to extend it out to dry when the weather is better. While the awning fabric itself won't mildew, mildew can form on the dust and dirt allowed to accumulate on the fabric. If the fabric is rolled up and stored when wet, the moisture will promote the formation of mildew. Do not use caustic cleaners.

CLEANING THE FABRIC

Cleaning the awning regularly will extend the life of the fabric and prevent the formation of mildew. Call 1-800-670-7071 to order a SunSetter Cleaning and Maintenance kit.

PROTECTING THE SUNSETTER FRAME

Your SunSetter awning contains extruded and die-cast aluminum components. These aluminum parts are powder-coated for long-lasting beauty.

(We have included a bottle of color-matched touch-up paint with your awning in the event that some area of the painted surface gets scratched during installation. Please use it as needed.)

LUBRICATION

Once a year, you may wish to lubricate the gray plastic bushing on the roller bar on the side opposite of the motor or gear crank unit. During extended use, dust may accumulate on this moving part and may cause a minor squeak as the awning opens or closes. Any type of light lubricant will eliminate this type of noise. You may also wish to lubricate the pivot point of the lateral arm elbows. - see figure 10

CAUTION: NEVER USE A BARBEQUE GRILL (Figure 11a), ANY TYPE OF PATIO HEATER (Figure 11b) OR FIREPLACE (Figure 11c) UNDER YOUR SUNSETTER AWNING.

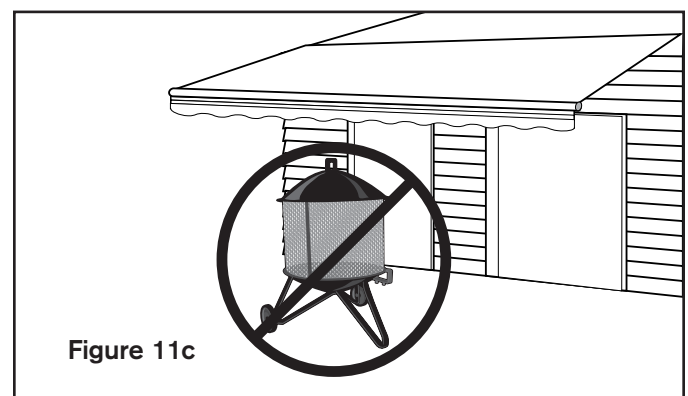
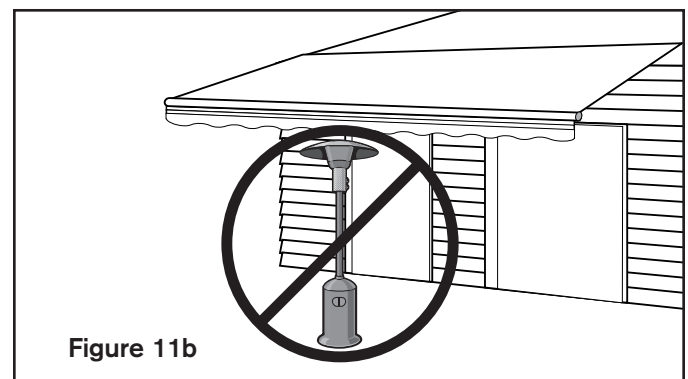
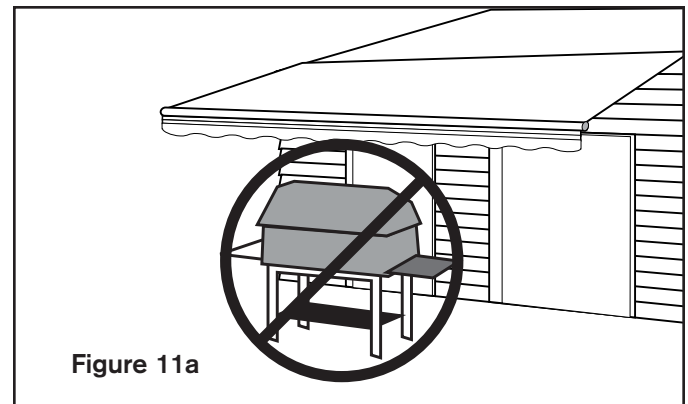

CARE AND MAINTENANCE OF YOUR ELECTRIC MOTOR AND REMOTE

WARNING: ANY PERMANENT WIRING OF THE AWNING MUST BE PERFORMED BY A LICENSED ELECTRICIAN PER YOUR LOCAL ELECTRICAL CODES. ANY TYPE OF MODIFICATION TO THE ELECTRIC MOTOR OR ITS WIRING WILL VOID THE WARRANTY ON THIS PRODUCT.

THE OUTDOOR ELECTRIC MOTOR

The motor is supplied by Somfy Systems Inc., the recognized world leader in specialized electric tubular motors for awnings and sunshades. This 110-volt motor is UL (Underwriters Laboratories) and CSA (Canadian Standards Association) approved. This Somfy motor features the manual override option that allows you the safety and convenience of manual operation during electrical failures.

The electric motor is equipped with an automatic overheat protection shutoff system. If you run your awning several times continuously, the motor will stop its operation. It will resume normal operation after several minutes of cooling down.

PROTECTING THE ELECTRIC MOTOR FROM WATER DAMAGE

To prevent water from entering the head of the motor, it is recommended that a drip loop be formed as shown in figure 11d. Notice that the bottom of the loop is lower than the cord's entry point to the motor. Rain water gaining access into the roller bar could damage the internal components of the motor. We strongly recommend that you call 1-800-670-7071 and purchase the SunSetterAwning Cover.

Installing the SunSetter Cover over your awning will reduce the risk of water damage to the motor.

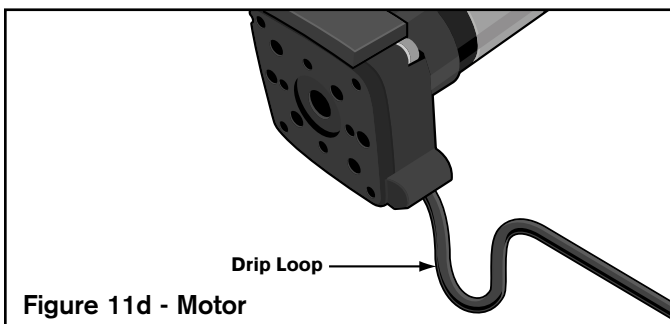

PROTECTING THE GFI ELECTRICAL OUTLET FROM WATER DAMAGE WHEN MOTOR POWER CORD IS PLUGGED IN

To prevent water from entering the outlet it is recommended that a drip loop be formed at the end of the power cord as shown in figure 11e. Additionally, it is recommended that an "In-Use Weatherproof Cover" is installed over the outlet, covers are available at most local hardware stores.

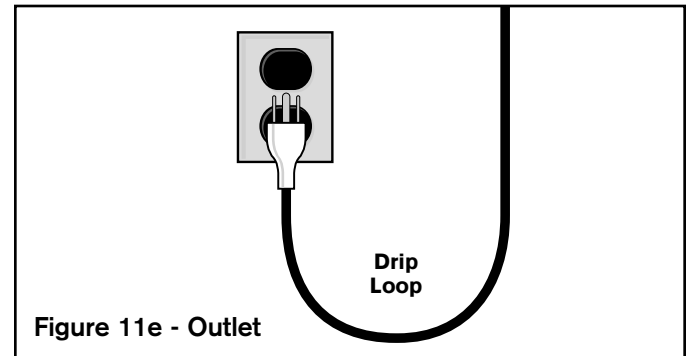

PREPARING YOUR AWNING FOR THE WINTER

Unplugging the motor power cord from your wall outlet and covering the socket may prevent rain and moisture from entering the outlet which could interfere with proper motor function in the Spring. Before rolling up your awning for the last time of the season, it may be beneficial to ensure the fabric is clean and dry which will prevent mildew from forming over the winter. To aid in Winter protection we strongly recommend the use of a SunSetter Awning Cover. If you do not have a cover and would like to order one, please call 1-800-670-7071. Installing the SunSetter Cover will keep your awning clean and ready for use on the first day of Spring.

CHANGING THE BATTERY ON YOUR REMOTE TRANSMITTER

Please note that you might have to replace the battery after 3 years, or if the remote transmitter stops working. You should find this type of battery (3V Lithium CR2430), in any local hardware store. To replace the battery, simply remove the small Phillips screw on the back of the remote transmitter, remove the back cover, replace the old battery and reinstall the back cover and Phillips screw. Be sure to note the orientation of the old battery as you remove it.

ENJOY YOUR SUNSETTER AWNING

APPENDIX A - CHANGING THE PITCH

There is one final adjustment you might need to make: Setting the pitch or angle of your awning.

Fully open the awning. Are you happy with the height and level of the front bar? If so, great! **You are done with the installation. Relax, and enjoy your awning.**

If not, you can adjust the pitch or angle of each arm separately.

1. Fully open the awning using your crank wand or remote transmitter as applicable. On motorized awnings, unplug the power cord from the outlet after opening the awning.

2. Have your helper slightly lift the front bar to take the weight off the arm. Then, use the supplied 6mm Allen wrench to loosen approximately 1/2 turn, but not remove, the three allen cap bolts on the side of the arm clamp -- see figure 12

Note: If you have a 10' awning, you may need to temporarily remove the override crank from the motor or the crank loop from the gear unit to allow easy access to the 3 Allen cap bolts. Simply reinstall the override crank or crank loop when you are done.

WARNING: RAISING THE FRONT BAR WILL REDUCE THE PITCH (ANGLE) OF THE FABRIC THUS INCREASING THE RISK OF RAIN WATER POOLING ON THE FABRIC. TO PREVENT THE AWNING FROM COLLAPSING DUE TO RAIN WATER LOAD, YOU MUST RETRACT THE AWNING WHEN UNATTENDED. FAILURE TO DO SO COULD RESULT IN PERSONAL INJURY.

To raise the front bar, continue with step 3.
To lower the front bar, proceed to step 7.

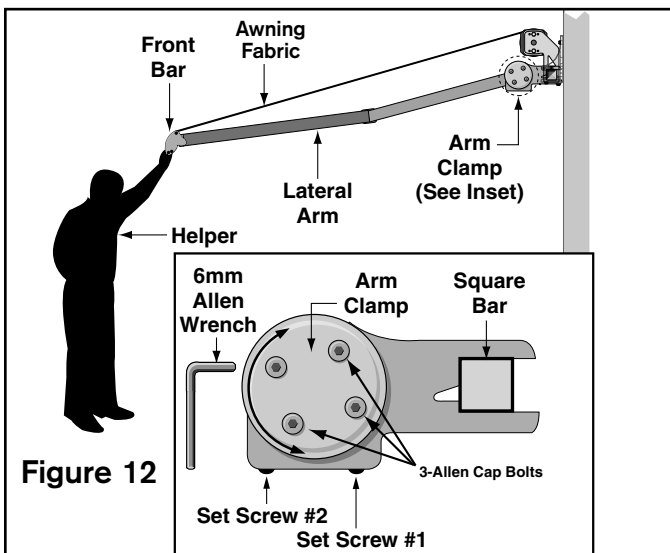

To Raise the Front Bar

3. Look at the bottom of the arm clamp. You will see two allen set screws (set screw #1 and set screw #2 on figure 12). To raise the front bar of the awning, first loosen the allen set screw closest to the square bar (set screw #1 on figure 12) by turning it counterclockwise.

4. Have your helper lift the arm to the desired height, then, rotate clockwise the Allen set screw farthest away from the square bar (set screw #2 on figure 12). Have your helper release the front bar to see if it reached the desired height. If you have gone too far, simply turn set screw #2 counterclockwise to lower the front bar. If the front bar is still not high enough, continue turning the set screw clockwise.

5. Once you have set the arm at the desired height, secure set screw #1 all the way in. Adjust the other arm the same way. **Make sure that the front bar is level.**

6. Tighten the three allen cap bolts on the side of each arm clamp.

Note: Depending on adjustments, the Open/Close position stops may need to be adjusted to correct any sagging that may occur to the fabric. Follow the procedures in Appendix B for your motor application.

You are now done with the installation. If you purchased a motorized awning plug the power cord into the outlet and enjoy your awning.

To Lower the Front Bar

7. Look at the bottom of the arm clamp. You will see two allen set screws (set screw #1 and set screw #2 on figure 12). To lower the front bar of the awning, loosen the allen set screw farthest away from the square bar (set screw #2 on figure 12), by turning it counterclockwise, until you reach the desired height. If you have gone too far, simply turn set screw #2 clockwise to raise the front bar (you might want your helper to lift the front bar a little to take off the weight from the set screw). If the front bar is still not low enough, continue turning the set screw counterclockwise.

8. Once you have reached the desired height, rotate clockwise the allen set screw closest to the square bar (set screw #1 on figure 12) until secured all the way in. Adjust the other arm the same way. **Make sure that the front bar is level.**

9. Tighten the three allen cap bolts on the side of each arm clamp.

Note: Depending on adjustments, the Open/Close position stops may need to be adjusted to correct any sagging that may occur to the fabric. Follow the procedures in Appendix B for your motor application.

You are now done with the installation. If you purchased a motorized awning plug the power cord into the outlet and enjoy your awning.

APPENDIX B

RESETTING THE LIMIT PUSH BUTTONS OF THE SUNSETTER MOTOR

IF THE MOTOR ON YOUR SUNSETTER AWNING IS MOUNTED ON THE RIGHT, AS YOU FACE THE HOUSE, COMPLETE STEPS 1 THRU 12. IF THE MOTOR ON YOUR SUNSETTER AWNING IS MOUNTED ON THE LEFT, AS YOU FACE THE HOUSE, COMPLETE STEPS 13 THRU 23 ON PAGE 15.

Awnings with Motors installed on the Right as you face the house

1. Press the Neutral/Middle button on the remote.
2. Unplug the power cord from the electrical outlet on the wall.
3. From a stepladder locate the limit push buttons on the motor. These push buttons will be on top of the motor housing under a black plastic protective cap – see Figure 13.
4. Grasp the black protective cap and lift it up. You will notice one yellow button and one white button inside a recessed area. These are the limit push buttons for the **OPEN** and **CLOSE** positions for the motorized awning.
5. Clear the Factory Settings by separately pressing both buttons (white and yellow) until they are both 'IN' or at their lowest point inside the recessed area of the motor housing –see figure 13. You should practice this a few times to understand this process.

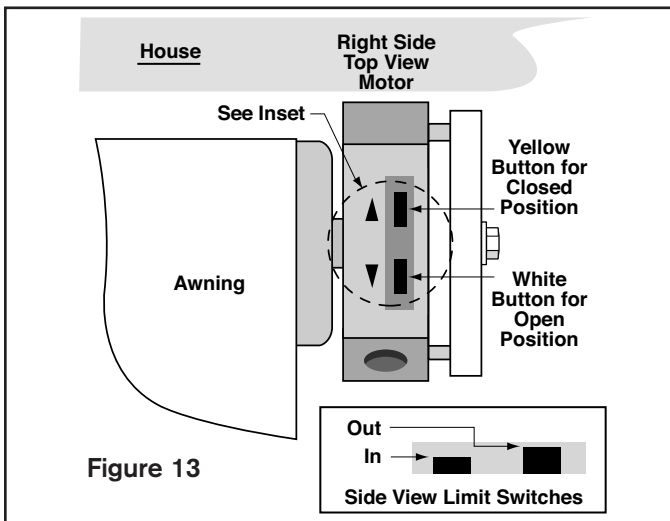

6. Manually crank the awning open to the point where both lateral arms 'lock' into the fully extended position. The fabric will also be at its tightest point.

NOTE: The fabric should be rolling over the top of the roller bar (figure 14a), not underneath (figure 14b). If the fabric is rolling from the bottom of the roller bar, continue unrolling the fabric until it rolls over the top of the roller bar. Then roll up the fabric until both lateral arms 'lock' and the fabric becomes tight.

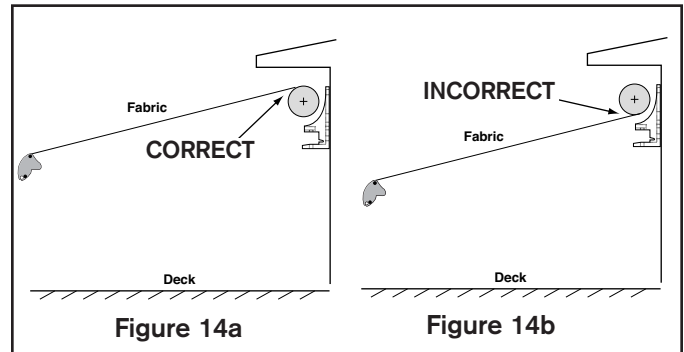

7. Depress the white button so that it is in the 'OUT' position (or closer to the top of the recessed area on the motor housing). Now the **OPEN** position stop is set.
8. Manually roll the awning up until it is almost completely closed. The area to watch is where the front bar almost touches the round side of the arm clamp – see figure 15. Leave about 1/2" gap between the front bar and the round side of the arm clamp.
9. Depress the yellow button so that it is in the 'OUT' position (or closer to the top of the recessed area on the motor housing). Now the **CLOSE** position stop is set.
10. Replace the black protective cap on the motor housing. Be careful that the cap will not accidentally depress one of the limit push buttons underneath.
11. Plug the power cord back into the electrical outlet on the wall.
12. Test the awning for proper operation.

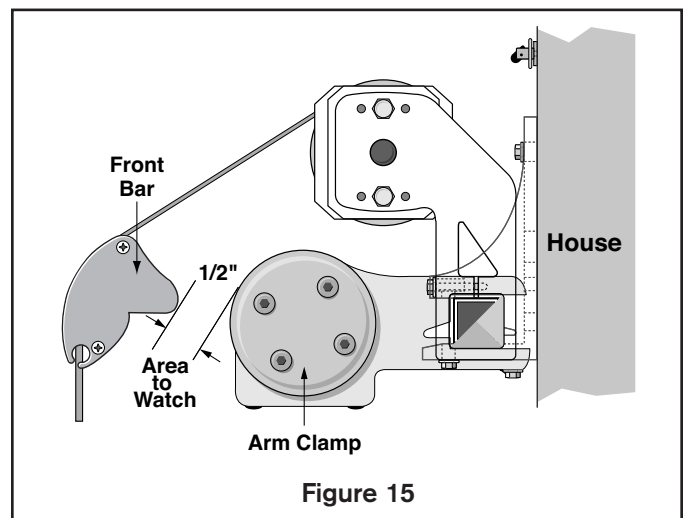

Awnings with Motors installed on the Left as you face the house

13. Press the Neutral/Middle button on the remote.

14. Unplug the power cord from the electrical outlet on the wall.

Note: Black protective cap for use with Right Motor Installations Only.

15. From a stepladder locate the limit push buttons on the motor. These push buttons will be on the underside of the motor housing. – see Figure 16.

16. You will notice one yellow button and one white button inside a recessed area. These are the limit push buttons for the **OPEN** and **CLOSE** positions for the motorized awning.

17. Clear the Factory Settings by separately pressing both buttons (white and yellow) until they are both 'IN' or at their lowest point inside the recessed area of the motor housing –see figure 16. You should practice this a few times to understand this process.

18. Manually crank the awning open to the point where both lateral arms 'lock' into the fully extended position. The fabric will also be at its tightest point.

NOTE: The fabric should be rolling over the top of the roller bar (figure 14a), not underneath (figure 14b). If the fabric is rolling from the bottom of the roller bar, continue unrolling the fabric until it rolls over the top of the roller bar. Then roll up the fabric until both lateral arms 'lock' and the fabric becomes tight.

19. Depress the yellow button so that it is in the 'OUT' position (or closer to the top of the recessed area on the motor housing). Now the **OPEN** position stop is set.

20. Manually roll the awning up until it is almost completely closed. The area to watch is where the front bar almost touches the round side of the arm clamp – see figure 17. Leave about 1/2" gap between the front bar and the round side of the arm clamp.

21. Depress the white button so that it is in the 'OUT' position (or closer to the top of the recessed area on the motor housing). Now the **CLOSE** position stop is set.

22. Plug the power cord back into the electrical outlet on the wall.

23. Test the awning for proper operation.

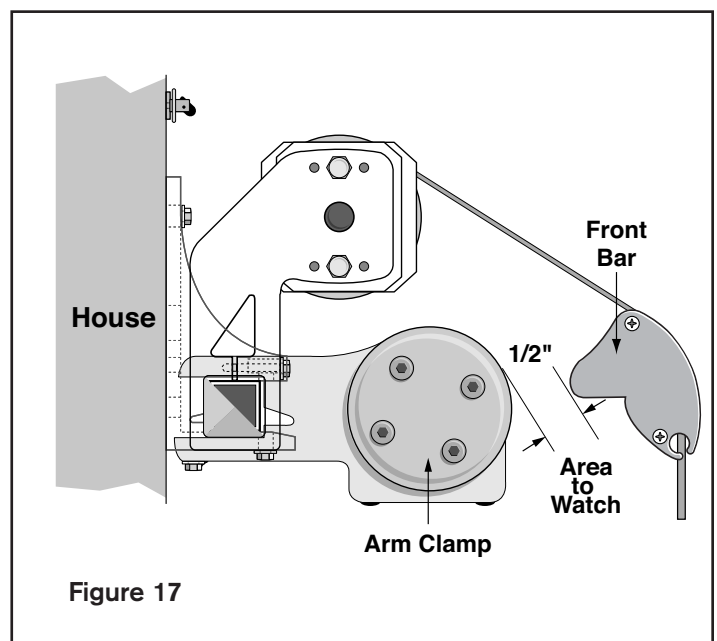
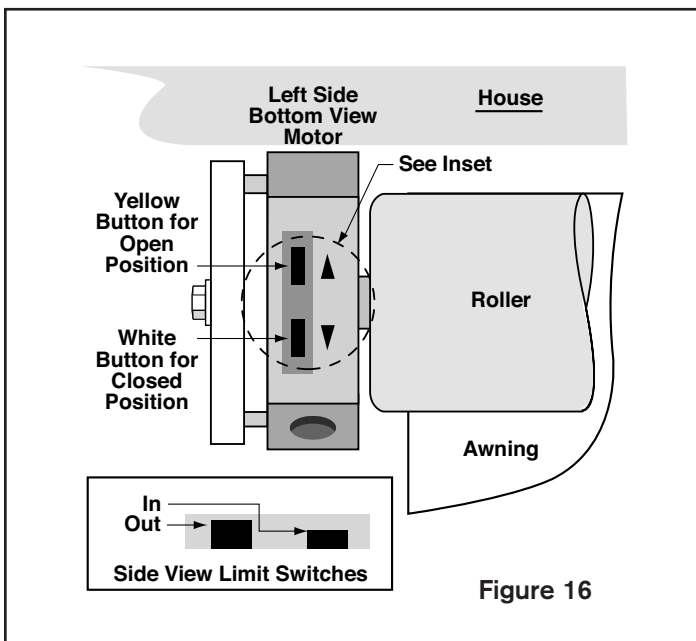

APPENDIX C - Soffit Mount

WARNING: Do not remove the plastic safety sleeves from the lateral arms until instructed to do so.

Note: The following instructions are for installing to a level overhang or soffit. If installing to an angled overhang or rafters, it may be necessary to use Rafter Adapter Brackets. These brackets may be purchased separately and utilized as shown in Figure 18a. Please call Customer Service at 800-670-7071 to purchase the Rafter Adapter Brackets.

Before starting:

1. Before beginning, please familiarize yourself with the components of the awning as shown in Figure 18. Find the mounting brackets in the package (they are separated from the awning itself).

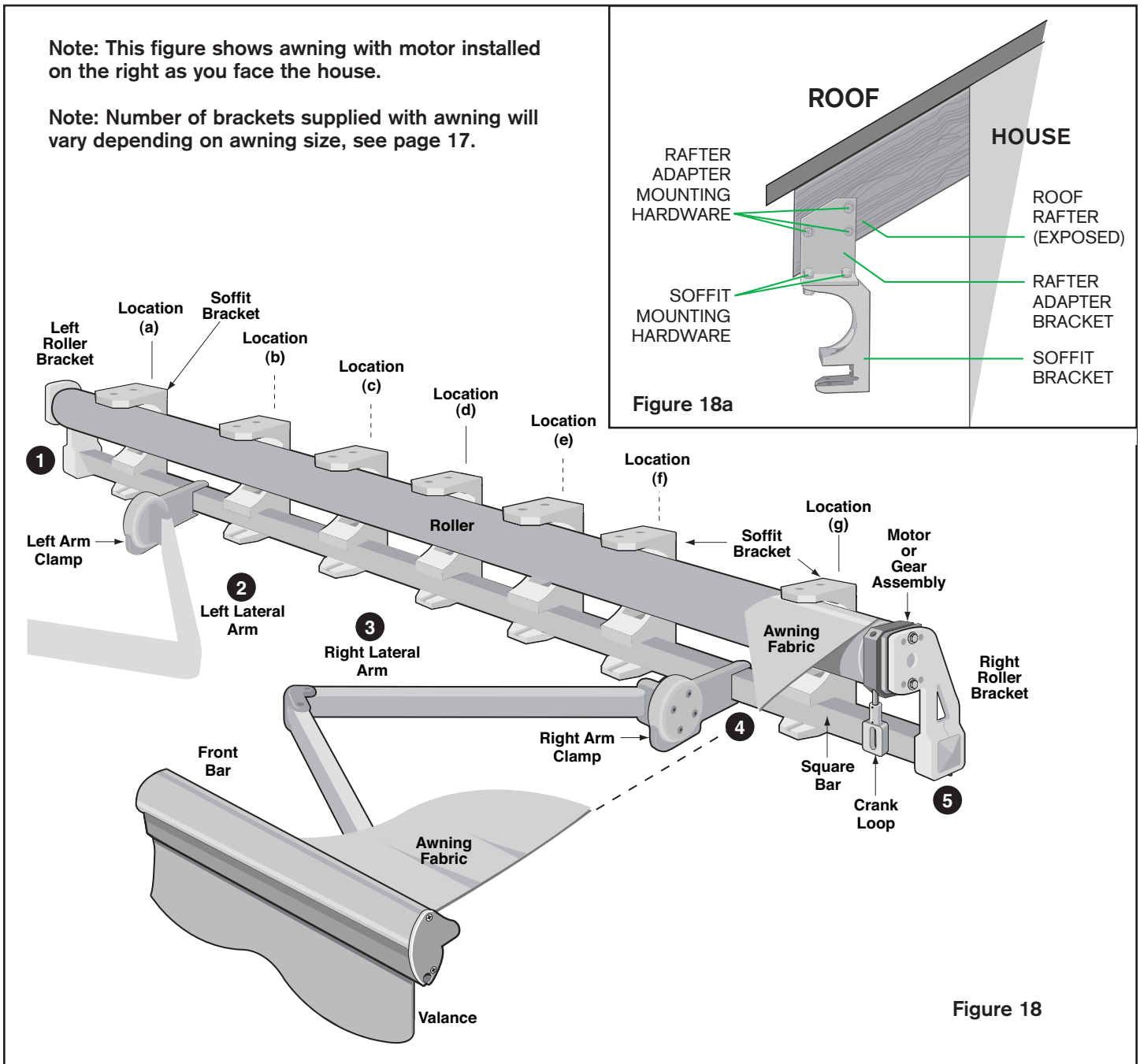

Figure 18b
Bracket locations for 10'-13' wide awnings.

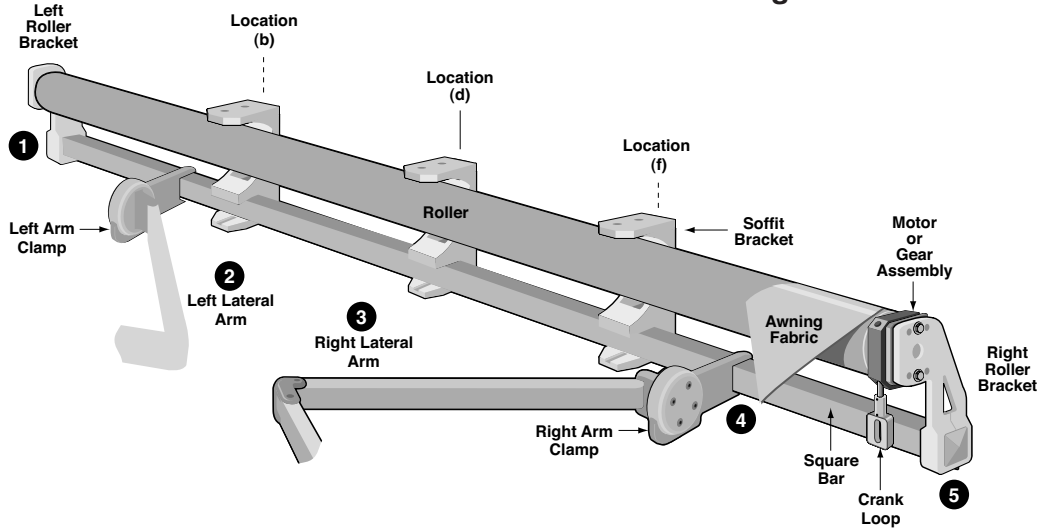

Figure 18c
Bracket locations for 14'-16' wide awnings.

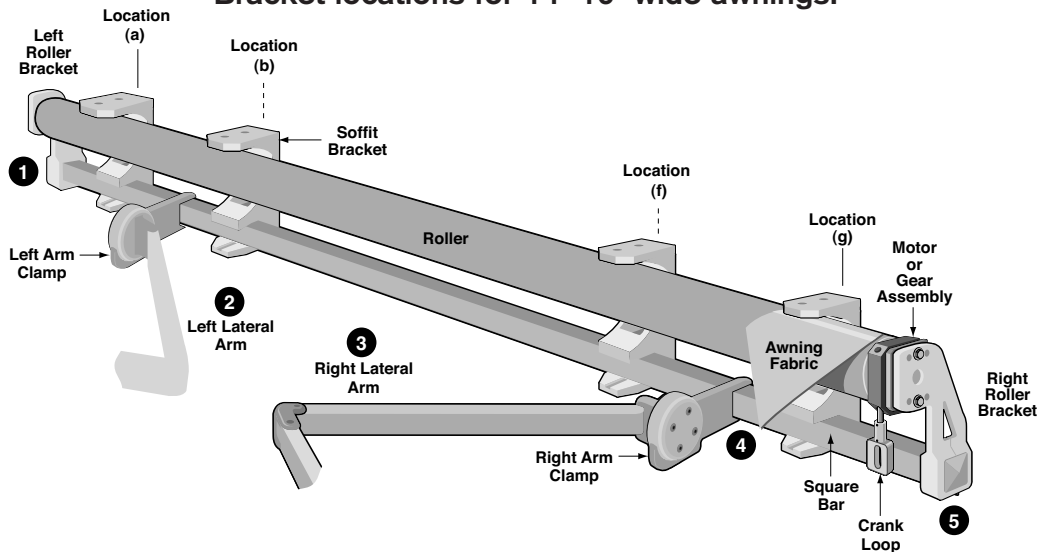
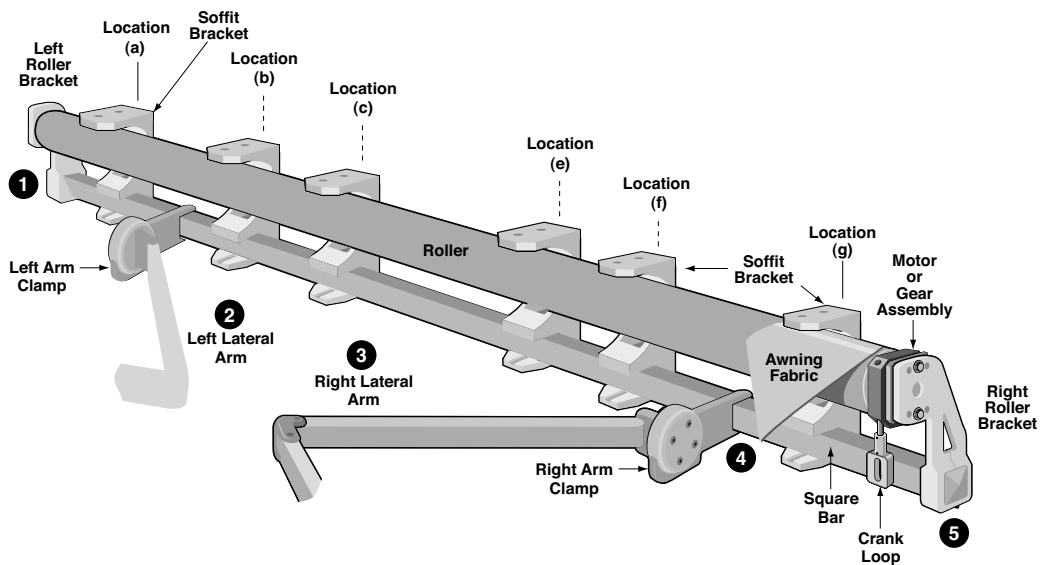

Figure 18d
Bracket locations for 17' & 18' wide awnings.



Tools Required

In your package you will find the following tools: a 6mm Allen wrench.

For installing the awning on the soffit, under the overhang, you will need an assistant, measuring tape, two step-ladders, 9/16" socket, chalk line (or string), Phillips screwdriver, pencil, a level, electric drill, 1/8" and 1/4" drill bits, 1/2" or 13mm wrench and a stud finder.

Mounting Line

2. Snap a horizontal straight line on the soffit, using the chalk line, the length of the awning. When you position your chalk line on the soffit, take into account that when retracted, the awning will project 10" from the chalk line -- see figure 19.

Note: For ease of mounting the awning to the brackets, it is very important that the line be straight.

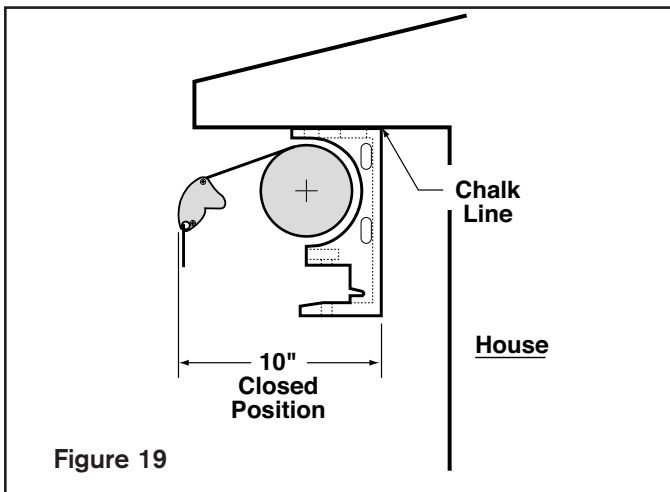

Figure 19

Locating the brackets

CAUTION: PROPER LOCATION OF THE BRACKETS IS THE MOST IMPORTANT ASPECT OF THE AWNING MOUNTING. IT IS CRITICAL THAT YOU FASTEN THE MOUNTING BRACKETS TO THE RAFTERS OR OTHER MAJOR STRUCTURAL MEMBERS.

Even a moderate wind exerts great force on the awning and mounting brackets. This is why it is most important that all the brackets will be fastened properly and securely. Proper location will also make it easier to insert the pre-assembled awning into the supporting brackets.

Note: Mount brackets only in the locations recommended for your size awning.

Note: You will need to use all brackets supplied for secure mounting.

For 10 ft thru 13 ft wide awnings, we recommend to install the three brackets supplied at the locations (b) (d) and (f) see Fig. 18b. For 14 ft, 15 ft and 16 ft wide awnings, we recommend to install four brackets supplied at the locations (a) (b) (f) and (g) see Fig. 18c. For 17 ft and 18 ft wide awnings, use six brackets supplied at locations (a) (b) (c) (e) (f) and (g) see Fig. 18d.

Location (a) – Between the left end of the awning and the left arm, on the rafter nearest to the left end.

Location (b) – Between the two arms, on the nearest rafter to the left arm.

Location (c) – On the nearest rafter midway between the middle point of the awning and the left arm.

Location (d) – The nearest rafter to the middle point of the awning. (Size 10' - 13' only)

Location (e) – On the nearest rafter midway between the middle point of the awning and the right arm.

Location (f) -- Between the two arms, on the nearest rafter to the right arm.

Location (g) – Between the right end of the awning and the right arm, on the rafter nearest to the right end.

Mounting the Brackets into the Soffit

3. On the chalk line you have marked on the soffit, mark the left and the right ends of the awning (points 1 & 5 in fig 18). With the exception of the 10' awning, which measures 123" left to right, all other awnings measure exactly like their defined size. (For example, a 12ft awning measures 144" from left to right). Using the chart below, mark on the chalk line the middle point and the points where the left and right arm clamps will be (points 2,3 & 4 in figure 18 respectively).

Note: The brackets cannot be installed in the area where the Arm Clamps are located.

Size	Left arm Clamp	Middle-Point	Right arm Clamp
10ft	1-1/4" from left end	61"	1-1/4" from right end
11ft	7" from left end	66"	7" from right end
12ft	8" from left end	72"	8" from right end
13ft	14" from left end	78"	14" from right end
14ft	20" from left end	84"	20" from right end
15ft	26" from left end	90"	26" from right end
16ft	32" from left end	96"	32" from right end
17ft	38" from left end	102"	38" from right end
18ft	44" from left end	108"	44" from right end

4. YOU MUST NOW LOCATE THE RAFTERS IN THE AREA IN WHICH THE BRACKET MUST BE INSTALLED AS EXPLAINED EARLIER IN "LOCATING THE BRACKETS". To find the rafters, use a stud finder. **Be sure to read the stud finder instructions before usage.** Mark the center of each rafter, on which a bracket will be installed with a 7" long line.

5. Position the bracket against the soffit, centered over the vertical line, with the back of the bracket even with the horizontal chalk line, (see Figure 19), and mark the two holes -- see figure 20.

6. Drill 1/4" pilot holes about 3-1/2" into the rafter. This will prevent the framing from splitting while installing the lag screws.

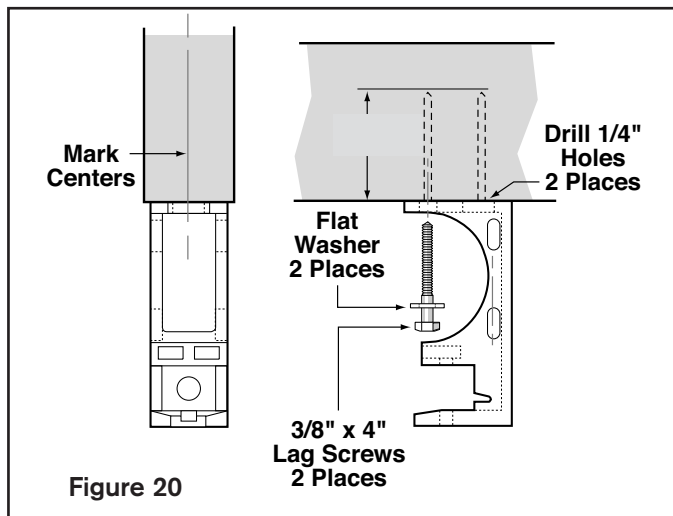

7. Using a 9/16" socket, install the bracket with the 3/8" x 4" long lag screws. Use the flat washer provided under the head of the screw. Make sure not to overtighten the lag screws; doing so may split the wood framing or weaken the screw -- see figure 20.

8. Repeat for all brackets.

WARNING: FAILURE TO SECURELY FASTEN THE BRACKETS TO THE SOFFIT OR FAILURE OF THE STRUCTURAL MEMBER TO SUPPORT AN AWNING COULD RESULT IN THE COLLAPSE OF THE AWNING AND CAUSE PERSONAL INJURY.

Note: If the protective cover was purchased together with your awning proceed to step 9. If not, proceed to step 17 on page 20 to continue with the installation of your awning.

Protective Cover - Soffit

9. Locate the supplied fasteners and screws used to secure the protective cover to the soffit-- see figure 22.

Note: We recommend installing the fasteners for the protective cover one at a time, beginning with the one to the far right. Once the first is installed, you will use the actual protective cover as the template for the grommet spacing between all holes.

10. Make a mark 1" in front of the bracket--see Figure 21.

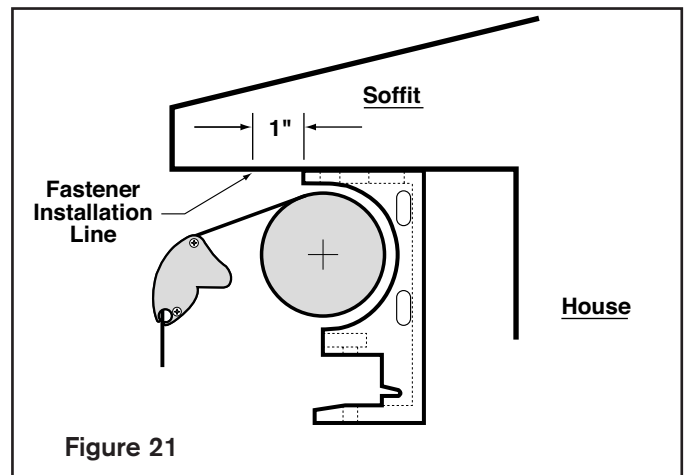

11. On the mark, snap a chalk level line along the entire length of the awning. On the chalk line, mark the location of the right end of the awning. Along the chalk line you just made, measure 1" further to the right of the awning end point and make a mark. This is the location of the first fastener on the right for the protective cover--see Figure 22.

12. Place one fastener on the mark. Orient the fastener so that the hook opening is facing in towards the house -- see figure 22.

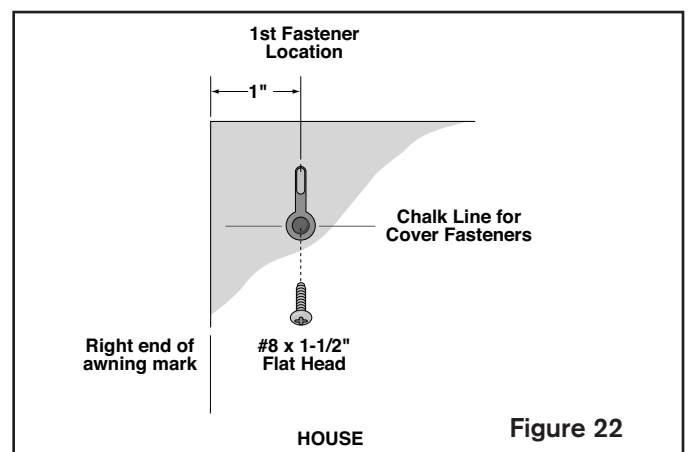

13. Using a 1/8" drill bit, drill a pilot hole approximately 1" deep. Secure the fastener with a #8 x 1-1/2" Phillips screw supplied.

14. Remove the cover from its packaging. Orient the cover so that the sewn hem is facing the house - see Figure 23. Place the first grommet of the protective cover on the first installed fastener.

15. Extend the cover to the left and keep it taut. Then mark the center of the next grommet hole centered on the chalk line.

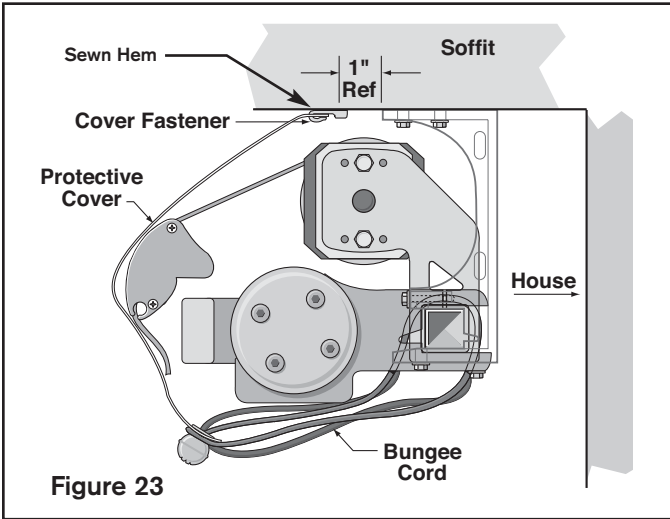

16. Repeat the previous steps for the remaining fasteners.

Note: The ends of the protective cover are designed to extend approximately 1-1/2" beyond the overall width of the awning.

Securing the Awning into the Brackets

17. Carefully remove all packaging from the awning. **DO NOT REMOVE THE PLASTIC SAFETY SLEEVES FROM THE ARMS** - see figure 10.

18. Separate the wand from the awning.

19. **All Models** - Insert a retaining nut into the special groove in each bracket - see figure 24.

20. With proper help, lift the awning (with fabric Roller Bar above the Square Bar) into the brackets and position so the ends line up with end points marked on the wall - see figure 25. Use the following weight chart to decide how much help you need.

Size	Weight Vista	Weight Motorized
10ft	78 lbs	84 lbs
11ft	83 lbs	89 lbs
12ft	90 lbs	96 lbs
13ft	95 lbs	101 lbs
14ft	100 lbs	106 lbs
15ft	105 lbs	111 lbs
16ft	110 lbs	116 lbs
17ft	115 lbs	121 lbs
18ft	120 lbs	126 lbs

21. Push the square bar into the brackets and secure with one retaining bolt in each bracket. Be sure to insert the bolt from the bottom of the bracket up. You might need to apply pressure on the square bar to permit insertion - see figure 24.

Return to "Checking your Awning for Proper Operation" [page 10](#) to complete the installation of your awning.

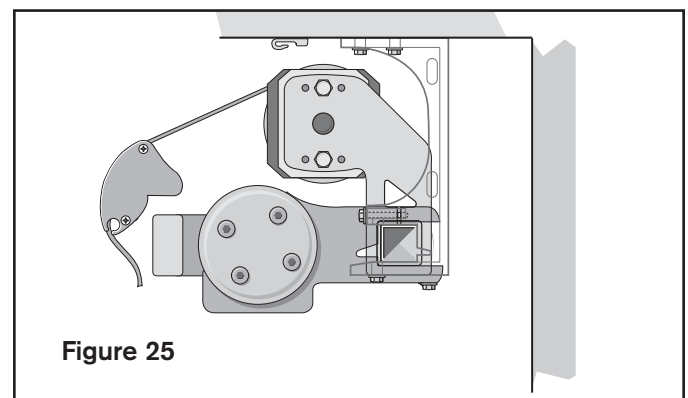
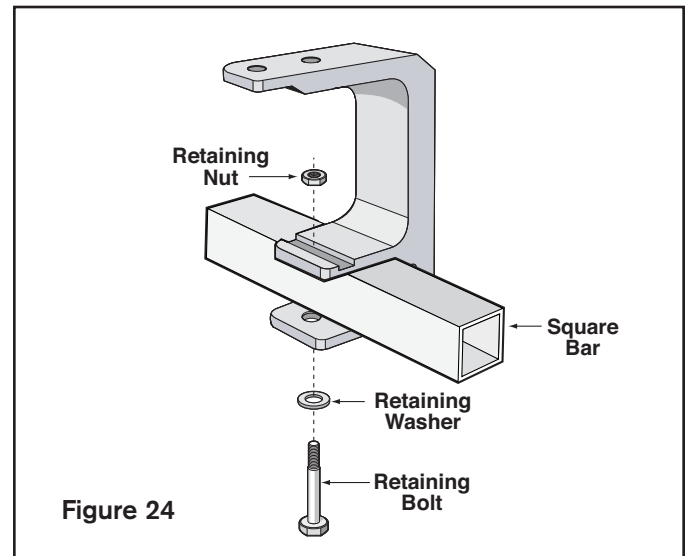

OFF SEASON STORAGE ONLY:

Use the supplied bungee cords to secure cover in place - see Figure 23. Slide the loop end of the bungee through the bottom grommets from the outside of the cover, pull the cord over and around the square bar and place over the ball that secures the cord.

Remove bungee cords before using your awning.

APPENDIX D

Resetting the Remote Transmitter

This procedure describes the actions needed to reset the Remote Transmitter **that was supplied with your Motorized awning**. This procedure should only be performed if the Remote Transmitter does not operate the Motorized awning. Please review the steps below to familiarize yourself with the procedure before attempting to complete them.

- Verify that the red light on the remote transmitter comes on when you press and hold the button. If the red light does not come on at all or blinks for less than 5 seconds, you will need to replace the battery (see Care and Maintenance section on page 12).
- Press the NEUTRAL (middle) button on the transmitter.
- Unplug the power cord from the wall.
- Insert the wand into the Override crank on the motor and manually open the awning approximately 3 feet but do not completely open.
- Plug the power cord back into the wall and make sure that there is electricity available. Let the awning sit **for one minute**, undisturbed, without pressing a button on the remote transmitter or unplugging the cord from the wall.
- Unplug the power cord from the wall for 2 seconds.
- Plug the power cord back in for 10 seconds.
- Unplug the power cord for 2 seconds.
- Plug the power cord back in and leave it plugged in.

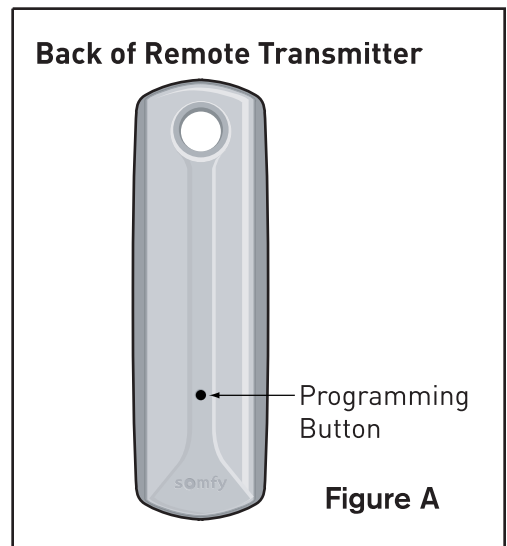

NOTE: The motor may rotate approximately 2 feet in one direction and stop.

When the motor stops, press and hold the programming button on the back of the Remote Transmitter (see figure A) for 5 seconds until the motor 'jogs', then release. (A 'jog' is a short back and forth movement of the motor).

Activate the transmitter by pressing the OPEN and CLOSE buttons at the same time, the motor will jog.

Press the programming button on the back of the Remote Transmitter until the motor jogs and release.

NOTE: If the motor does not operate, you will have to clear the OPEN/CLOSE stop settings on the motor. Please complete **ONLY** steps 1 thru 5 of Appendix B (page 14) if your motor is on the right side, or steps 13 thru 17 of Appendix B (page 15) if your motor is on the left side. After clearing the OPEN/CLOSE stop settings, verify if the transmitter operates the awning. If not, return to this page and repeat the procedure listed above.

Your Remote Transmitter is now reset to operate your Motorized awning. Test the awning for proper operation. If you cleared the OPEN/CLOSE stop settings on the motor, go to Appendix B on page 14 to reset them.

Add/Delete a Control Device (Transmitter, Remote Wall Switch, Wind Sensor)

To **ADD** an additional Control Device (not the one that was supplied with the awning):

- Press the programming button on the back of the transmitter that was supplied with the awning until the motor 'jogs'- see Figure A.
- On the additional Control Device, press the programming button until the motor 'jogs', then release.

If you wish to **DELETE** a control device, simply repeat the 2 steps listed above.

TROUBLESHOOTING

Problem with Installation	Solution
Stud finder is not locating a stud on my exterior wall	You may need to locate a stud on the inside wall and transfer the location to the outside wall. Make sure to measure from a common point (window/door frame, etc).
Can I "hard-wire" a switch into my home?	SunSetter cannot be responsible for any changes in the electrical configuration of the motorized awning. Have your electrician contact Somfy (the motor manufacturer) directly via their website, www.somfysystems.com . Hardwiring will void the warranty on the motor and on other awning electrical components. (Remote, cable, etc).
How low can the pitch be set?	As low as a 45 degree angle.
Problem with Appearance	Solution
Fabric wrinkles when the awning is opened/closed	The awning fabric has a hem along both ends of the material; some wrinkling is a characteristic of the extra thickness along either edge. This wrinkling may be more noticeable when retracted and after prolonged periods when the awning is not used. This condition is normal. Leaving the awning open in warm weather should minimize the wrinkling over a period of time.
Lateral arms (elbows) are not even when awning is retracted	<ul style="list-style-type: none"> • Each lateral arm is supported individually to the square bar. Therefore, it is normal that when the awning is closed, the arms may not necessarily be even with each other when viewed from the front or underside of the awning. • Insure that fabric is evenly centered on Roller bar and Front Bar. This will assist the lateral arm in closing more evenly.
The roller bar and fabric appear to bounce when opening and closing the awning.	The roller bar that holds the fabric is supported only at the extreme ends and it bows toward the center. As the Roller Bar rotates, it may move up and down toward the center. This is a natural tendency of the bar and may be more noticeable with larger sized awnings.
My fabric is rubbing against the arm clamps when it is opening/closing	<ul style="list-style-type: none"> • The fabric should not come in contact with the hardware when it is opening or closing. Check and make sure the fabric is rolling over the top of the roller bar. (see Appendix B, figure 14a and 14b). • Check the setting of open stop. It should be set when both arms are fully extended and in the "locked" position arms. (see Resetting limit push buttons, Appendix B)

TROUBLESHOOTING - Continued

Problem with Motor or Gear	Solution
When opening or closing the VISTA awning the drive unit binds, skips or spins freely.	The drive unit gears may have been stripped or damaged during operation. Please call Customer Service for possible replacement.
After installing, the awning will not function	<ul style="list-style-type: none"> • Is there power to the receptacle? • Verify that the red light is on the remote transmitter comes on when you press and hold a button • If red light does not come on, remove battery and reinsert in slot and try pushing button again, If no light - see changing battery on page 12. • You may need to reprogram the remote transmitter – see Appendix D • You may need to reset the OPEN/CLOSE limit push buttons on the motor – See Appendix B
The red light on the remote transmitter does not come on when I press and hold the button	<ul style="list-style-type: none"> • Remove the battery and reinsert in slot and try pushing button again, if no light replace battery. • Replace the battery (CR2430) following the instructions on page 12
Awning rolls out but will not retract	Reset the OPEN/CLOSE limit push buttons using the installation instruction manual – see Appendix B
Awning retracts but will not roll out	Reset the OPEN/CLOSE limit push buttons using the installation instruction manual – see Appendix B
Awning rolls out and keeps going and fabric starts to sag	Reset the OPEN/CLOSE limit push buttons using the installation instruction manual – see Appendix B
Awning will not open or retract using the Manual Override Crank	The remote must be in the NEUTRAL position in order for the manual override to operate correctly when using the crank. If necessary, you can also unplug the cord from the electrical receptacle.
Remote transmitter, can I use more than one	Yes, you can purchase an additional transmitter from SunSetter Products and follow the installation instruction manual – Appendix D, to set the additional transmitter
After opening and closing the awning several times, the motor suddenly stopped working and will not close or open the rest of the way	<p>The overtemperature sensor has temporarily shutoff the motor. The motor will resume normal operation after about 15 minutes of cooling down.</p> <p>Note: If the awning is in the closed position and ambient temperature is elevated, it might take a little longer.</p>
When operating my awning the GFI on the outlet keeps tripping and interrupting the power supply to the awning	<ul style="list-style-type: none"> • First test the GFI by plugging in another appliance (such as a hairdryer) to insure outlet is working properly, if OK. • Test awning by getting power from other outlet inside the house using an extension cord, if OK. • There may be moisture in the motor housing causing the GFI to trip, please allow motor to dry over 2-3 sunny days. Motor is designed to operate if it gets wet and dries out. • Installing the SunSetter cover over your awning will reduce the risk of rain-water affecting the operation of the motor.

HOW TO DRAIN RAIN WATER FROM THE AWNING FABRIC

WARNING: THE SUNSETTER AWNING IS NOT DESIGNED TO HOLD THE WEIGHT OF RAINWATER POOLING ON THE FABRIC. ACCUMULATION OF RAINWATER ON THE FABRIC COULD COLLAPSE THE AWNING AND CAUSE SERIOUS INJURY!

If, for any reason, rainwater accumulated on the fabric, follow the instructions below to remove the water. You will need a helper for this procedure.

WARNING: NEVER WALK UNDER AN AWNING WITH WATER ACCUMULATED ON THE FABRIC! THERE COULD BE A TREMENDOUS AMOUNT OF WEIGHT ON THE AWNING AND THE FRAME COULD COLLAPSE AT ANY MOMENT AND CAUSE SERIOUS INJURY!

1. Connect a common garden hose to your outside water faucet.
2. While standing in front of the awning (BUT NOT UNDER THE AWNING), visually observe where is the deepest point of the water pooling on the fabric.
3. Hold the open end of the garden hose about head high. DO NOT ALLOW ANY WATER TO RUN ONTO THE FABRIC.
4. Have a helper turn the water faucet on. Let water run ONTO THE GROUND until there is a solid stream of water.
5. Continue to hold the end of the hose head high and have your helper turn the water OFF. Leave the hose connected to the faucet.
6. Place the end of the hose over the front of the awning and let the open end of the hose slide into the deepest point of the water pool. DO NOT GO UNDER THE AWNING!
7. While the open end of the hose is UNDER THE SURFACE OF THE WATER, have your helper disconnect the water hose from the faucet and lay it on the ground.
8. The siphon caused by the water running out of the hose will drain the water from your awning. Let the water continue to drain until the flow of the water through the hose stops.
9. While keeping the end of the hose submerged, move it around on the fabric to keep it under the surface of the water to fully drain the water from the fabric.
10. When the drain stops, make sure most of the water was drained. If not, repeat the process until most of the water is drained off of the fabric.
11. Close the awning and let the rest of the water run off totally from the fabric.
12. Inspect your awning for damaged parts, and check for normal operation.

5-Year Limited Warranty – Awning and Accessories VISTA and Motorized Models Only

A. WHO GIVES THIS WARRANTY?

SunSetter Products, 184 Charles Street, Malden, MA 02148.

B. WHO IS ENTITLED TO THIS WARRANTY?

This Warranty applies only to the original purchaser who paid for the product and may not be assigned or transferred to subsequent owners. This Warranty applies only to products purchased and installed in the US.

C. WHAT ARE THE RESPONSIBILITIES OF SUNSETTER PRODUCTS UNDER THIS WARRANTY?

Subject to the terms and conditions set forth herein, SunSetter Products will furnish replacements for parts found by SunSetter Products to be defective in design, manufacture or assembly, under each specific component or product warranty as set forth below.

D. WHAT ARE THE RESPONSIBILITIES OF THE ORIGINAL PURCHASER UNDER THE WARRANTY?

1. Before any claims may be made under this Warranty, the original purchaser must have paid in full for the product covered under the Warranty, according to the terms and conditions of the pay-plan defined in the original order. **IF THE PURCHASER HAS FAILED TO MAKE FULL PAYMENTS ACCORDING TO THE SPECIFIC PAY PLAN FOR THE PRODUCT, THIS WARRANTY SHALL BE NULLIFIED AND SUNSETTER PRODUCTS SHALL BE RELIEVED FROM ANY RESPONSIBILITY OR LIABILITY UNDER THIS WARRANTY.** The purchaser agrees and acknowledges that this Warranty agreement constitutes an executory contract.

2. The purchaser must use care in installation, maintenance, operation, use, and storage of the product in accordance with the instructions contained in the owner's manual. **ANY FAILURE TO INSTALL, MAINTAIN, OPERATE, USE AND STORE THE PRODUCT IN ACCORDANCE WITH THE INSTRUCTIONS CONTAINED IN THE OWNER'S MANUAL WILL NULLIFY THIS WARRANTY AND RELIEVE SUNSETTER PRODUCTS FROM ANY RESPONSIBILITY OR LIABILITY UNDER THIS WARRANTY.**

3. Promptly notify SunSetter Products of any claims.

4. The purchaser may be required to provide a photograph of any defective parts. The purchaser may also be required to pay a deposit until the defective parts are returned to SunSetter Products for inspection. The purchaser must obtain a return authorization form from SunSetter Products' customer service department prior to the return of any merchandise and after having received such authorization, return the part or product, freight prepaid, to SunSetter Products.

E. WHAT IS COVERED UNDER THIS WARRANTY?

1. The following components of the SunSetter Lateral Arm Awning and its accessories (defined as accessories attached to the awning) are covered under this Warranty, subject to the limitations set forth below. These components have a five (5) year limited (prorated) warranty, against manufacturer's defects as outlined below:

(a) Should the purchaser promptly notify SunSetter Products of such defects within one year (12 months) from the date of the original purchase, the defective component will be replaced at no charge.

(b) After one year but within five years (60 months) from the date of the original purchase, a defective component will be replaced upon the purchaser's payment of 1/60th of the full retail cost of the component for each month of use prior to the claim.

2. Covered Components:

STRUCTURAL SUPPORTS, which include the lateral arms, the square bar, the front bar and all other attached supports are warranted not to fail for five (5) years provided that the components are not subjected to excessive winds or water pooling on the fabric.

ROLLER BAR is warranted for five (5) years against any and all damage including cracking and permanent bowing that would affect the performance of the awning, provided that the awning is not subjected to excessive winds or water pooling on the fabric.

FABRIC is warranted for five (5) years against:

(a) Excessive fading under normal conditions if maintained, operated, used, and stored in accordance with the instructions contained in the owner's manual.

(b) Mildew on the fabric. Mildew will not form on the fabric itself, but may form on dirt and dust that have not been removed from it. Please see maintenance instructions for proper cleaning-outlined in owner's manual.

(c) Excessive cracking or peeling under normal conditions if maintained, operated, used, and stored in accordance with the instructions contained in the owner's manual, and provided that the awning is not subjected to excessive winds or water pooling on the fabric.

GEAR MECHANISM (VISTA Model only) is warranted for five (5) years not to fail under normal conditions if maintained, operated, used, and stored in accordance with the instructions contained in the owner's manual.

ELECTRIC MOTOR (Motorized Models only) is warranted for five (5) years not to fail under normal conditions if maintained, operated, used, and stored in accordance with the instructions contained in the owner's manual.

AWNING ACCESSORIES (defined as accessories attached to the awning) are warranted for five (5) years not to fail under normal conditions if maintained, operated, used, and stored in accordance with the instructions contained in the owner's manual.

F. WHAT IS NOT COVERED UNDER THIS WARRANTY?

1. The SunSetter awnings are not designed to be used for carports and are not designed to be installed on moving vehicles. Any damage that results from the Purchaser's use of SunSetter awnings for carports or on moving vehicles is not covered by this warranty.

2. Any failure or damage of the components that results from any intentional or negligent actions by the purchaser or by any other person is not covered by this Warranty.

5-Year Limited Warranty – Awning and Accessories VISTA and Motorized Models Only (continued)

3. It is the responsibility of the purchaser to securely fasten the awning to studs, joists, headers or other structural members. Any failure or damage that results from the awning falling from its installed position is not covered by this Warranty.
4. Labor charges connected with installation of replacement parts are not covered by this Warranty.
5. Freight expenses to and from SunSetter Products in shipping damaged or replacement parts are not covered by this Warranty and must be paid by the purchaser.
6. Stretching of fabric or damage to any structural component caused by wind or water pooling on the fabric or any other weather are not covered by this Warranty.
7. Any modification or addition to the awning structure and support system or to the electric motor or its wiring will nullify this Warranty and relieve SunSetter Products from any responsibility or liability under this Warranty.

G. GENERAL PROVISIONS AND LIMITATIONS

1. **THE WARRANTY GRANTED HEREIN IS THE EXCLUSIVE REMEDY FOR THE PURCHASER. SUNSETTER PRODUCTS MAKES NO OTHER WARRANTIES TO THE PURCHASER, EXPRESS, STATUTORY, IMPLIED OR OTHERWISE AND ALL IMPLIED WARRANTIES, INCLUDING WITHOUT LIMITATIONS, IMPLIED WARRANTIES OF MERCHANTABILITY AND FITNESS FOR A PARTICULAR PURPOSE, ARE HEREBY DISCLAIMED.**
2. **TO THE EXTENT PERMITTED BY LAW, SUNSETTER PRODUCTS SHALL HAVE NO LIABILITY TO THE PURCHASER OR ANY OTHER PERSON FOR INCIDENTAL, SPECIAL, CONSEQUENTIAL, INDIRECT OR SIMILAR DAMAGES OF ANY KIND OR NATURE WHATSOEVER, WHETHER ARISING OUT OF BREACH OF WARRANTY OR OTHER BREACH OF CONTRACT, NEGLIGENCE OR OTHER TORT, OR OTHERWISE, EVEN IF SUNSETTER PRODUCTS SHALL HAVE BEEN ADVISED OF THE POSSIBILITY OR LIKELIHOOD OF SUCH POTENTIAL LOSS OR DAMAGE. IN NO EVENT SHALL SUNSETTER PRODUCTS BE LIABLE FOR LOSS OF PROFITS AND/OR WAGES.**
3. Some states do not allow limitations on how long an implied warranty lasts, or do not allow the exclusion or limitation of incidental or consequential damages, so the above limitations may not apply to you.
4. This warranty gives you specific rights and you may have other rights which vary from state to state.

Free Manuals Download Website

<http://myh66.com>

<http://usermanuals.us>

<http://www.somanuals.com>

<http://www.4manuals.cc>

<http://www.manual-lib.com>

<http://www.404manual.com>

<http://www.luxmanual.com>

<http://aubethermostatmanual.com>

Golf course search by state

<http://golfingnear.com>

Email search by domain

<http://emailbydomain.com>

Auto manuals search

<http://auto.somanuals.com>

TV manuals search

<http://tv.somanuals.com>