



HP 5900 and HP FlexFabric 5700 switches meet the requirement of FIPS security level 2.

Components of the opacity shield kit



Opacity shield
(1 in total)



M3 hex bolt
(3 in total)



M3 countersunk-head
screw (3 in total)

Tamper evidence label

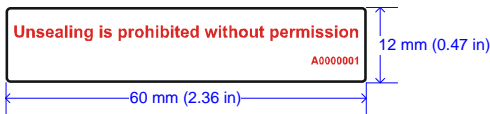

Tamper evidence labels do not come with the FIPS opacity shield kit. You must order them from HP by using the product code JG585A (30 count) or JG586A (100 count).

Applicable products

- HP 5900AF-48G-4XG-2QSFP+ Switch (JG510A)
- HP 5900AF-48G-4XG-2QSFP+ TAA-compliant Switch (JH038A)
- HP FlexFabric 5700-48G-4XG-2QSFP+ Switch (JG894A)
- HP FlexFabric 5700-48G-4XG-2QSFP+ TAA-compliant Switch (JG895A)

Preparing for installation

- The installation procedures must be performed by qualified personnel.
- Before installation, read the compliance and safety manual for the compatible device of the FIPS opacity shield kit.
- Wear an ESD wrist strap, and make sure the wrist strap makes good skin contact and is reliably grounded.

- Make sure the operating temperature is not higher than 40°C (104°F).
- Ensure enough clearance for installation.
- Face the front of the chassis to locate the installation positions (left and right).
- If the device has been mounted in a rack, remove it from the rack.

Installing the opacity shield

Only use the screws and hex bolts that are supplied in the opacity shield kit to secure the opacity shield.

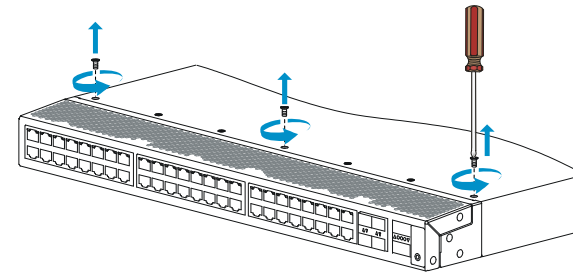

Remove the three screws from the top of the chassis.

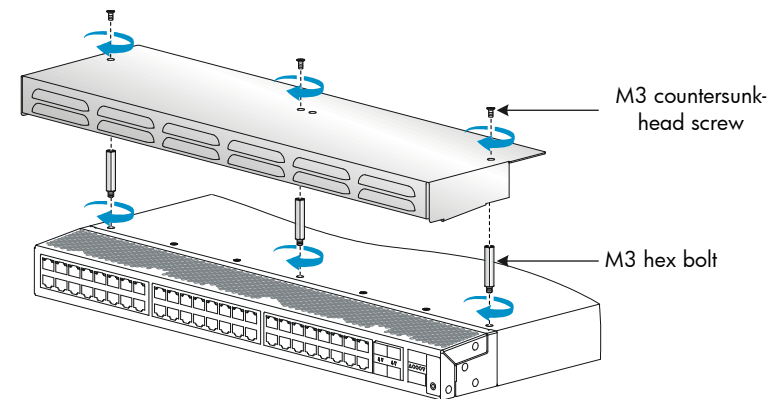

Attach the opacity shield to the top of the chassis.

Applying tamper evidence labels

- ⚠ Apply tamper evidence labels to all field replacement units (such as the FIPS enclosure, power supplies, and fan trays), USB ports, and any screw on an opacity shield.
- If the device is to be installed in a rack, HP recommends that you apply tamper evidence labels before installing the device in the rack.
- Before applying tamper evidence labels, use alcohol-based cleaning pads to clean the chassis. Allow the cleaned area to air dry for 5 minutes.
- Make sure the chassis temperature is above 10°C (50°F).

💬 The tamper evidence labels in these figures are for illustration only.

Applying tamper evidence labels (chassis front view)

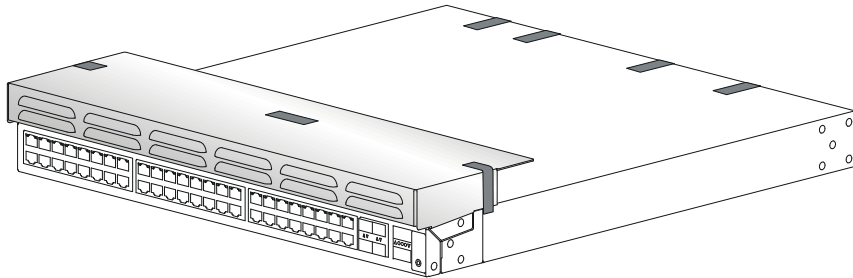

Applying tamper evidence labels (chassis rear view)

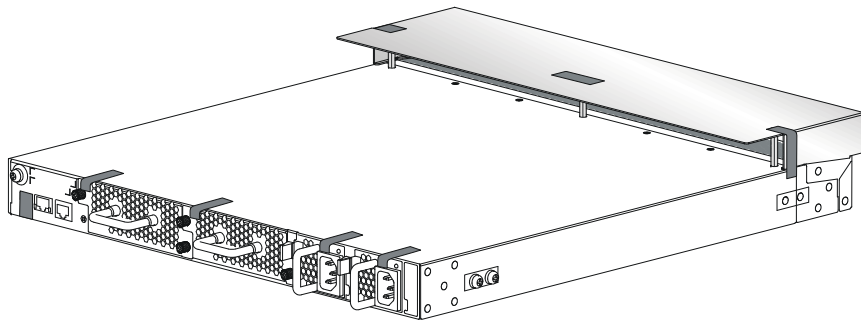

Documentation

To find related documents, browse to the Manuals page of the HP Business Support Center website:

<http://www.hp.com/support/manuals>



5998-6342

Free Manuals Download Website

<http://myh66.com>

<http://usermanuals.us>

<http://www.somanuals.com>

<http://www.4manuals.cc>

<http://www.manual-lib.com>

<http://www.404manual.com>

<http://www.luxmanual.com>

<http://aubethermostatmanual.com>

Golf course search by state

<http://golfingnear.com>

Email search by domain

<http://emailbydomain.com>

Auto manuals search

<http://auto.somanuals.com>

TV manuals search

<http://tv.somanuals.com>