

# HP ProLiant DL120 Gen9 Server User Guide

## Abstract

This document is for the person who installs, administers, and troubleshoots servers and storage systems. HP assumes you are qualified in the servicing of computer equipment and trained in recognizing hazards in products with hazardous energy levels.



Part Number: 781878-001a  
December 2014  
Edition: 2

© Copyright 2014 Hewlett-Packard Development Company, L.P.

The information contained herein is subject to change without notice. The only warranties for HP products and services are set forth in the express warranty statements accompanying such products and services. Nothing herein should be construed as constituting an additional warranty. HP shall not be liable for technical or editorial errors or omissions contained herein.

Linux® is the registered trademark of Linus Torvalds in the U.S. and other countries.

Microsoft®, Windows®, and Windows Server® are U.S. registered trademarks of the Microsoft group of companies.

microSD® is a trademark or a registered trademark of SD-3C in the United States, other countries or both.

Red Hat® is a registered trademark of Red Hat, Inc. in the United States and other countries.

VMware® is a registered trademark or trademark of VMware, Inc. in the United States and/or other jurisdictions.

---

# Contents

Component identification .....	7
Front panel components .....	7
Front panel LEDs and buttons .....	8
Power fault LEDs .....	9
Rear panel components .....	10
Rear panel LEDs .....	10
PCIe riser board slot definitions .....	11
System board components .....	12
DIMM slot locations .....	13
System maintenance switch .....	13
NMI functionality .....	14
Drive numbering .....	14
Hot-plug drive LED definitions .....	14
Fan locations .....	16
Operations .....	17
Power up the server .....	17
Power down the server .....	17
Extend the server from the rack .....	17
Remove the server from the rack .....	18
Remove the security bezel (optional) .....	18
Remove the access panel .....	19
Install the access panel .....	20
Remove the air baffle .....	20
Install the air baffle .....	21
Remove the PCI riser cage .....	22
Install the PCI riser cage .....	23
Setup .....	26
Optional installation services .....	26
Optimum environment .....	26
Space and airflow requirements .....	26
Temperature requirements .....	27
Power requirements .....	28
Electrical grounding requirements .....	28
Server warnings and cautions .....	28
Rack warnings .....	29
Identifying the contents of the server shipping carton .....	30
Installing hardware options .....	30
Installing the server into the rack .....	30
Installing the rack rail hook-and-loop strap .....	34
Powering on and selecting boot options .....	34
Installing the operating system .....	35
Registering the server .....	36
Hardware options installation .....	37
Introduction .....	37

Security bezel option .....	37
Drive options .....	37
Drive installation guidelines .....	38
Installing a non-hot-plug drive.....	38
Installing a hot-plug drive.....	40
Drive cable options.....	41
Mini-SAS cable options .....	41
Controller options.....	44
Installing a storage controller and FBWC module .....	44
Installing the battery pack .....	46
Optical drive option .....	47
Redundant fan option .....	50
Fan population guidelines.....	51
Installing a hot-swap fan module.....	51
Memory options .....	53
HP SmartMemory .....	53
Single-, dual-, and quad-rank DIMMs .....	54
DIMM identification .....	55
Memory configurations.....	55
General DIMM slot population guidelines.....	56
Installing a DIMM .....	57
FlexibleLOM option .....	58
PCIe x8 Full-height riser option .....	61
Expansion board options.....	63
Redundant power supply option .....	66
GPU enablement option .....	68
HP Trusted Platform Module option .....	71
Installing the Trusted Platform Module board .....	71
Retaining the recovery key/password .....	73
Enabling the Trusted Platform Module.....	73
<b>Cabling .....</b>	<b>75</b>
Cabling overview .....	75
Storage cabling .....	75
Four-bay LFF non-hot-plug drive cabling .....	75
Four-bay LFF hot-plug drive cabling .....	76
Eight-bay SFF hot-plug drive cabling .....	78
FBWC cabling.....	79
HP Smart Storage battery cabling.....	81
HP Power supply cabling.....	81
Optical drive cabling.....	82
Front I/O cabling.....	83
GPU cabling.....	84
<b>Software and configuration utilities .....</b>	<b>85</b>
Server mode .....	85
Product QuickSpecs.....	85
HP iLO.....	85
Active Health System.....	86
HP RESTful API support for HP iLO .....	87
Integrated Management Log .....	87
HP Insight Remote Support.....	88
Intelligent Provisioning .....	88
HP Insight Diagnostics .....	89

Erase Utility .....	89
Scripting Toolkit for Windows and Linux.....	90
HP Service Pack for ProLiant .....	90
HP Smart Update Manager.....	90
HP UEFI System Utilities.....	91
Using HP UEFI System Utilities .....	91
Flexible boot control .....	91
Restoring and customizing configuration settings .....	92
Secure Boot configuration.....	92
Embedded UEFI shell .....	93
Embedded Diagnostics option.....	93
HP RESTful API support for UEFI.....	93
Re-entering the server serial number and product ID.....	93
Utilities and features .....	94
HP Smart Storage Administrator .....	94
Automatic Server Recovery .....	94
USB support.....	94
Redundant ROM support .....	95
Keeping the system current .....	95
Access to HP Support Materials.....	95
Updating firmware or System ROM .....	96
Drivers .....	97
Software and firmware.....	98
Operating System Version Support .....	98
Version control.....	98
HP operating systems and virtualization software support for ProLiant servers.....	99
HP Technology Service Portfolio .....	99
Change control and proactive notification .....	99
<b>Troubleshooting .....</b>	<b>100</b>
Troubleshooting resources .....	100
<b>System battery replacement.....</b>	<b>101</b>
<b>Regulatory information .....</b>	<b>103</b>
Safety and regulatory compliance .....	103
Belarus Kazakhstan Russia marking .....	103
Turkey RoHS material content declaration.....	104
Ukraine RoHS material content declaration.....	104
Warranty information .....	104
<b>Electrostatic discharge.....</b>	<b>105</b>
Preventing electrostatic discharge .....	105
Grounding methods to prevent electrostatic discharge.....	105
<b>Specifications.....</b>	<b>106</b>
Environmental specifications .....	106
Mechanical specifications .....	106
Power supply specifications .....	107
Hot-plug power supply calculations.....	107
<b>Support and other resources .....</b>	<b>108</b>
Before you contact HP.....	108
HP contact information.....	108
Customer Self Repair .....	108

Acronyms and abbreviations.....	116
Documentation feedback .....	121
Index.....	122

# Component identification

## Front panel components

- Four LFF drive model

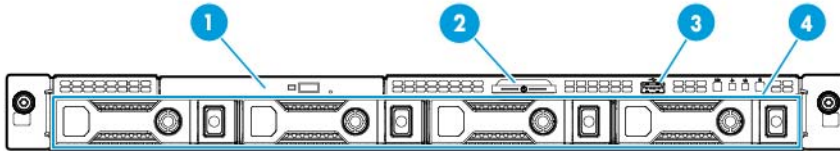

Item	Description
1	Optical drive (optional)
2	Serial label pull tab*
3	USB 2.0 connector
4	LFF drives

\*The serial number/iLO information pull tab is double-sided. The top side shows the server serial number and the customer asset tag label. The reverse side shows the default iLO account information and QR code linking to product documentation resources. The serial number/iLO information is also printed on labels attached to the chassis.

- Eight SFF drive model

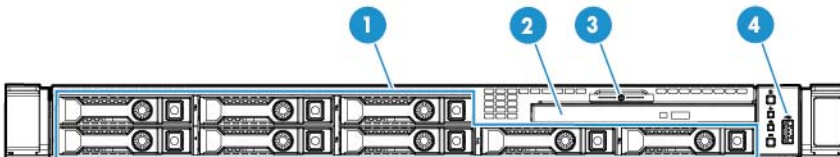

Item	Description
1	SFF drives
2	Optical drive (optional)
3	Serial label pull tab*
4	USB 2.0 connector

\*The serial number/iLO information pull tab is double-sided. The top side shows the server serial number and the customer asset tag label. The reverse side shows the default iLO account information and QR code linking to product documentation resources. The serial number/iLO information is also printed on labels attached to the chassis.

# Front panel LEDs and buttons

- Four LFF drive model

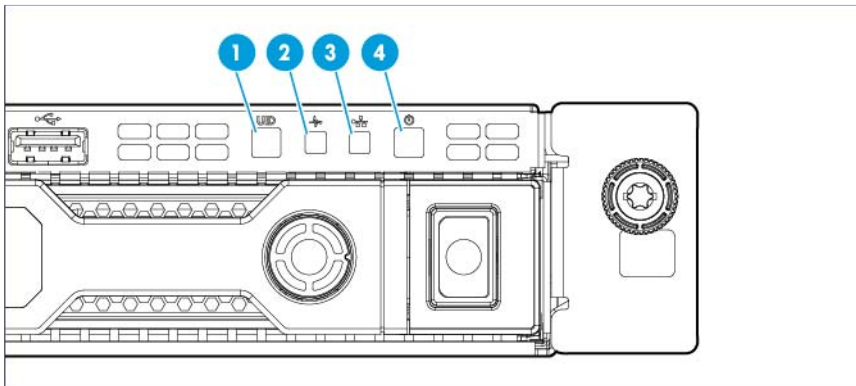

Item	Description	Status
1	UID button/LED*	Solid blue = Activated Flashing blue: <ul style="list-style-type: none"> <li>• 1 Hz/cycle per sec = Remote management or firmware upgrade in progress</li> <li>• 4 Hz/cycle per sec = iLO manual reboot sequence initiated</li> <li>• 8 Hz/cycle per sec = iLO manual reboot sequence in progress</li> </ul> Off = Deactivated
2	Health LED*	Solid green = Normal Flashing green (1 Hz/cycle per sec) = iLO is rebooting. Flashing amber = System degraded** Flashing red (1 Hz/cycle per sec) = System critical**
3	NIC status LED*	Solid green = Link to network Flashing green (1 Hz/cycle per sec) = Network active Off = No network activity
4	Power On/Standby button and system power LED*	Solid green = System on Flashing green (1 Hz/cycle per sec) = Performing power on sequence Solid amber = System in standby Off = No power present†

\*When all four LEDs described in this table flash simultaneously, a power fault has occurred. For more information, see "Power fault LEDs (on page 9)."

\*\*If the health LED indicates a degraded or critical state, review the system IML or use iLO to review the system health status.

†Facility power is not present, power cord is not attached, no power supplies are installed, power supply failure has occurred, or the power button cable is disconnected.



- Eight SFF drive model

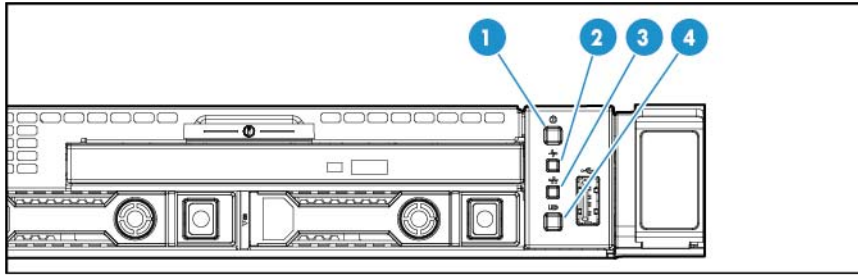

Item	Description	Status
1	Power On/Standby button and system power LED*	Solid green = System on Flashing green (1 Hz/cycle per sec) = Performing power on sequence Solid amber = System in standby Off = No power present
2	Health LED*	Solid green = Normal Flashing green (1 Hz/cycle per sec) = iLO is rebooting. Flashing amber = System degraded** Flashing red (1 Hz/cycle per sec) = System critical**
3	NIC status LED*	Solid green = Link to network Flashing green (1 Hz/cycle per sec) = Network active Off = No network activity
4	UID button/LED*	Solid blue = Activated Flashing blue: <ul style="list-style-type: none"> <li>• 1 Hz/cycle per sec = Remote management or firmware upgrade in progress</li> <li>• 4 Hz/cycle per sec = iLO manual reboot sequence initiated</li> <li>• 8 Hz/cycle per sec = iLO manual reboot sequence in progress</li> </ul> Off = Deactivated

\*When all four LEDs described in this table flash simultaneously, a power fault has occurred. For more information, see "Power fault LEDs (on page 9)."

\*\*If the health LED indicates a degraded or critical state, review the system IML or use iLO to review the system health status.

†Facility power is not present, power cord is not attached, no power supplies are installed, power supply failure has occurred, or the power button cable is disconnected.

## Power fault LEDs

The following table provides a list of power fault LEDs, and the subsystems that are affected. Not all power faults are used by all servers.

Subsystem	LED behavior
System board	1 flash
Processor	2 flashes
Memory	3 flashes
Riser board PCIe slots	4 flashes
FlexibleLOM	5 flashes
Removable HP Flexible Smart Array controller/Smart SAS HBA controller	6 flashes

Subsystem	LED behavior
System board PCIe slots	7 flashes
Power backplane or storage backplane	8 flashes
Power supply	9 flashes

## Rear panel components

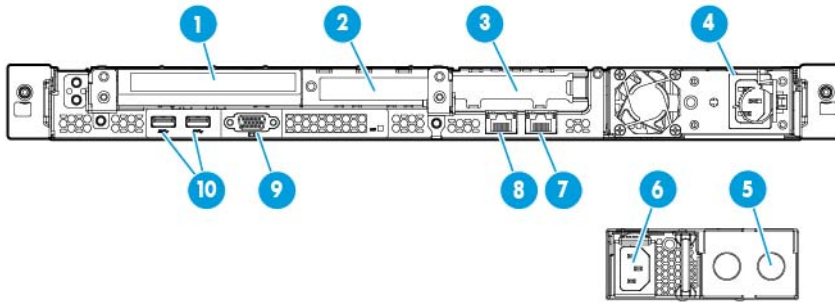

Item	Description
1	Slot 3 PCIe3 x8 (8, 4, 1)*
2	Slot 2 PCIe3 x8 (8, 4, 1)
3	Slot 1 PCIe3 x16 (16, 8, 4, 1)
4	Non-hot-plug power supply
5	Power supply blank (bay 2 of optional redundant power supply module)
6	Hot-plug power supply (bay 1 of optional redundant power supply module)
7	NIC connector 2
8	NIC connector 1/iLO connector
9	Video connector
10	USB 3.0 connectors

\* Slot 3 supports PCIe x16 (16, 8, 4, 1) if the GPU riser cage is installed.

## Rear panel LEDs

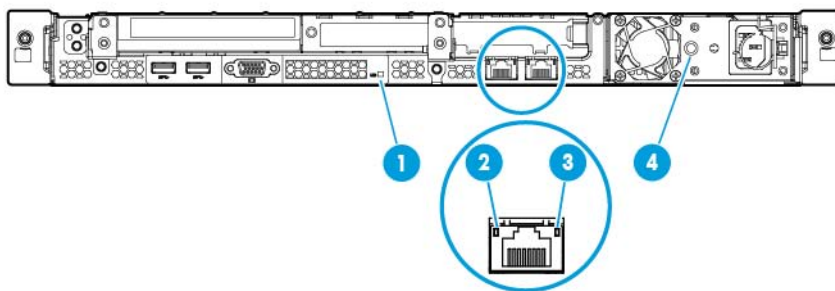

Item	Description	Status
1	UID LED	Solid blue = Activated Flashing blue: <ul style="list-style-type: none"> <li>• 1 Hz/cycle per sec = Remote management or firmware upgrade in progress</li> <li>• 4 Hz/cycle per sec = iLO manual reboot sequence initiated</li> <li>• 8 Hz/cycle per sec = iLO manual reboot sequence in progress</li> </ul> Off = Deactivated
2	NIC link LED	Green = Network link Off = No network link
3	NIC activity LED	Solid green = Link to network Flashing green = Network active Off = No network activity
4	Power supply LED	Solid green = Normal Off = One or more of the following conditions exists: <ul style="list-style-type: none"> <li>• Power is unavailable</li> <li>• Power supply failed</li> <li>• Power supply is in standby mode</li> <li>• Power supply error</li> </ul>

## PCIe riser board slot definitions

Slot number	Type	Length	Height	Connector link width	Negotiable link width
1	PCIe3	Half	Half	x16	x16
2	PCIe3	Half	Half	x8	x8
3*	PCIe3	Half	Full	x8	x8

\* Slot 3 can also support a full-height/full-length x16 GPU or a FlexibleLOM riser. When a x16 riser is installed, slot 2 is not available.

# System board components

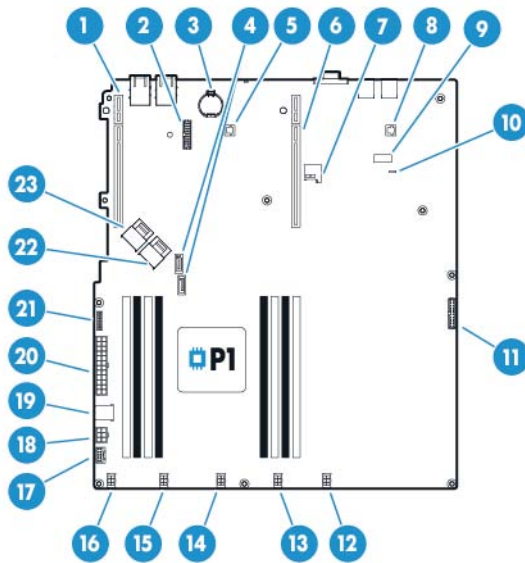

Item	Description
1	Primary PCIe riser board connector*
2	TPM connector
3	System battery
4	SATA connector
5	Storage backup power connector for PCIe slots 1-2*
6	Secondary PCIe riser slot*
7	MicroSD slot
8	Storage backup power connector for PCIe slot 3*
9	System maintenance switch
10	NMI header
11	Front I/O connector
12	Fan connector 5
13	Fan connector 4
14	Fan connector 3
15	Fan connector 2
16	Fan connector 1
17	HP Smart Storage Battery connector
18	6-pin drive backplane power connector
19	Internal USB 3.0
20	24-pin power connector
21	16 pin RPS connector
22	Mini-SAS connector 1
23	Mini-SAS connector 2

\* For more information on the riser board slots supported by the onboard PCIe riser connectors, see "PCIe riser board slot definitions (on page 11)."

## DIMM slot locations

DIMM slots are numbered sequentially (1 through 8). The supported AMP modes use the letter assignments for population guidelines.

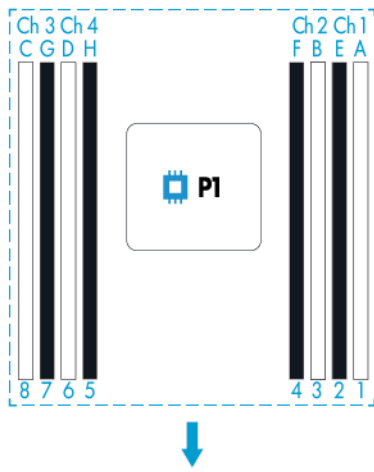

The arrow points to the front of the server.

## System maintenance switch

Position	Default	Function
S1	Off	Off = iLO 4 security is enabled. On = iLO 4 security is disabled.
S2	Off	Off = System configuration can be changed. On = System configuration is locked.
S3	Off	Reserved
S4	Off	Reserved
S5	Off	Off = Power-on password is enabled. On = Power-on password is disabled.
S6	Off	Off = No function On = ROM reads system configuration as invalid.
S7	Off	Off = Set default boot mode to UEFI. On = Set default boot mode to legacy.
S8	—	Reserved
S9	—	Reserved
S10	—	Reserved
S11	—	Reserved
S12	—	Reserved

To access the redundant ROM, set S1, S5, and S6 to on.

When the system maintenance switch position 6 is set to the On position, the system is prepared to erase all system configuration settings from both CMOS and NVRAM.



**CAUTION:** Clearing CMOS and/or NVRAM deletes configuration information. Be sure to properly configure the server or data loss could occur.



**IMPORTANT:** Before using the S7 switch to change to Legacy BIOS Boot Mode, be sure the HP Dynamic Smart Array B140i Controller is disabled. Do not use the B140i controller when the server is in Legacy BIOS Boot Mode.

## NMI functionality

An NMI crash dump creates a crash dump log before resetting a system which is not responding.

Crash dump log analysis is an essential part of diagnosing reliability problems, such as failures of operating systems, device drivers, and applications. Many crashes freeze a system, and the only available action for administrators is to restart the system. Resetting the system erases any information which could support problem analysis, but the NMI feature preserves that information by performing a memory dump before a system reset.

To force the system to invoke the NMI handler and generate a crash dump log, do one of the following:

- Use the iLO Virtual NMI feature.
- Short the NMI header.

For more information, see the HP website (<http://www.hp.com/support/NMI>).

## Drive numbering

- Four-bay LFF drive model

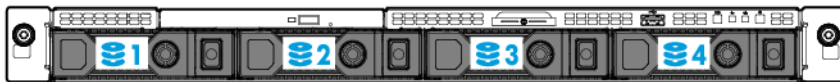

- Eight-bay SFF drive model



## Hot-plug drive LED definitions

Identify an HP SmartDrive by its carrier, shown in the following illustration.

When a drive is configured as a part of an array and connected to a powered-up controller, the drive LEDs indicate the condition of the drive.

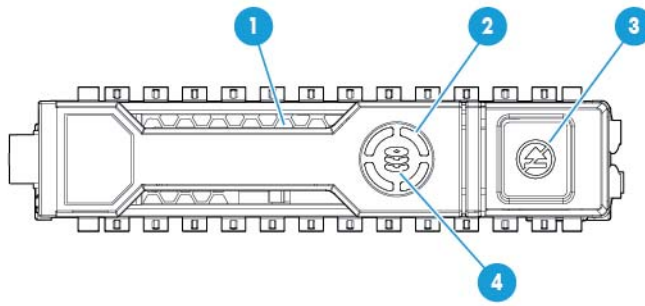

Item	LED	Status	Definition
1	Locate	Solid blue	The drive is being identified by a host application.
		Flashing blue	The drive carrier firmware is being updated or requires an update.
2	Activity ring	Rotating green	Drive activity
		Off	No drive activity
3	Do not remove	Solid white	Do not remove the drive. Removing the drive causes one or more of the logical drives to fail.
		Off	Removing the drive does not cause a logical drive to fail.
4	Drive status	Solid green	The drive is a member of one or more logical drives.
		Flashing green	The drive is rebuilding or performing a RAID migration, strip size migration, capacity expansion, or logical drive extension, or is erasing.
		Flashing amber/green	The drive is a member of one or more logical drives and predicts the drive will fail.
		Flashing amber	The drive is not configured and predicts the drive will fail.
		Solid amber	The drive has failed.
		Off	The drive is not configured by a RAID controller.

# Fan locations

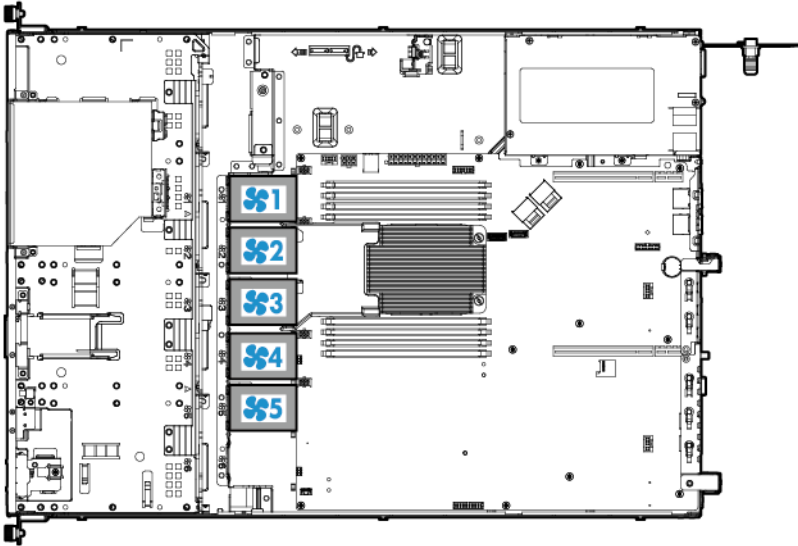



---

# Operations

## Power up the server

1. Connect each power cord to the server.
2. Connect each power cord to the power source.
3. Press the Power On/Standby button.

The server exits standby mode and applies full power to the system. The system power LED changes from amber to green.

## Power down the server

Before powering down the server for any upgrade or maintenance procedures, perform a backup of critical server data and programs.



---

**WARNING:** To reduce the risk of personal injury, electric shock, or damage to the equipment, disconnect the power cord to remove power from the server. The front panel Power On/Standby button does not completely shut off system power. Portions of the power supply and some internal circuitry remain active until the power cord is disconnected.

---



---

**IMPORTANT:** When the server is in standby mode, auxiliary power is still being provided to the system.

---

To power down the server, use one of the following methods:

- Press and release the Power On/Standby button.  
This method initiates a controlled shutdown of applications and the OS before the server enters standby mode.
- Press and hold the Power On/Standby button for more than 4 seconds to force the server to enter standby mode.  
This method forces the server to enter standby mode without properly exiting applications and the OS. If an application stops responding, you can use this method to force a shutdown.
- Use a virtual power button selection through iLO 4.  
This method initiates a controlled remote shutdown of applications and the OS before the server enters standby mode.

Before proceeding, verify the server is in standby mode by observing that the system power LED is amber.

## Extend the server from the rack

To extend the server from an HP, Compaq-branded, Telco, or third-party rack:



---

**WARNING:** To reduce the risk of personal injury or equipment damage, be sure that the rack is adequately stabilized before extending a component from the rack.

---



---

**WARNING:** To reduce the risk of personal injury, be careful when pressing the server rail-release latches and sliding the server into the rack. The sliding rails could pinch your fingers.

---

1. Do one of the following:
  - In a server that uses thumbscrew rack ears, loosen the captive thumbscrews that secure the server faceplate to the front of the rack, and then slide the server out of the rack.
  - In a server that uses quick-release latch rack ears:
    - i. Open the latches on both sides of the server.
    - ii. If necessary, use a T-25 Torx screwdriver to loosen the shipping screws.
    - iii. Slide the server out of the rack.
2. After performing the installation or maintenance procedure, slide the server back into the rack, and then press the server firmly into the rack to secure it in place.
3. Do one of the following:
  - In a server that uses thumbscrew rack ears, tighten the captive thumbscrews,
  - In a server that uses quick-release latch rack ears, if necessary, tighten the shipping screws.

## Remove the server from the rack



---

**WARNING:** This server is very heavy. To reduce the risk of personal injury or damage to the equipment:

- Observe local occupational health and safety requirements and guidelines for manual material handling.
  - Get help to lift and stabilize the product during installation or removal, especially when the product is not fastened to the rails. HP recommends that a minimum of two people are required for all rack server installations. A third person may be required to help align the server if the server is installed higher than chest level.
  - Use caution when installing the server in or removing the server from the rack; it is unstable when not fastened to the rails.
- 

To remove the server from an HP, Compaq-branded, Telco, or a third-party rack:

1. Power down the server (on page 17).
2. Extend the server on the rack rails until the server rail-release latches engage.
3. Disconnect all peripheral cables from the server.
4. Disconnect each power cord from the server.
5. Remove the server from the rack.

For instructions on how to extend or remove the server from the rack, see the documentation that ships with the rack rail system.

6. Place the server on a sturdy, level surface.

## Remove the security bezel (optional)

The security bezel is only supported in servers using the quick-release latch rack ears.

To access the front panel components, unlock and then remove the security bezel.

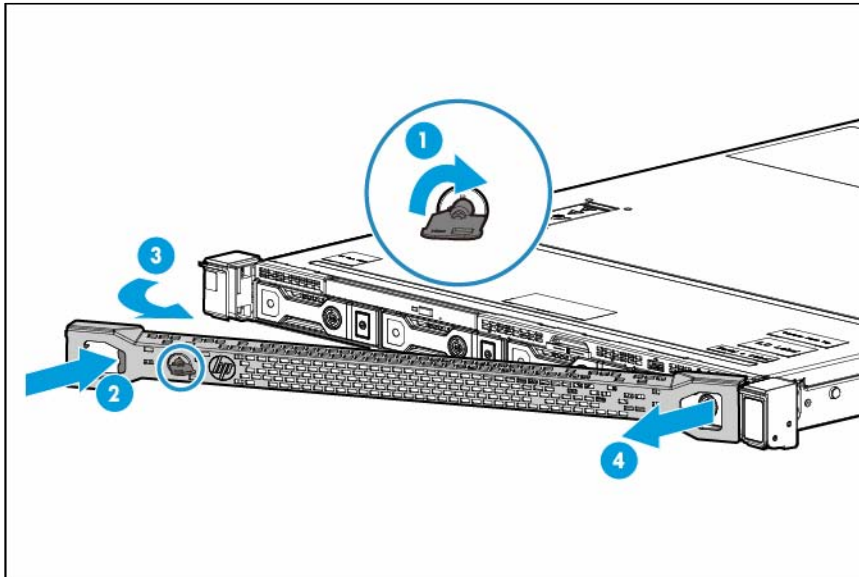

## Remove the access panel

**⚠ WARNING:** To reduce the risk of personal injury from hot surfaces, allow the drives and the internal system components to cool before touching them.

**⚠ CAUTION:** Do not operate the server for long periods with the access panel open or removed. Operating the server in this manner results in improper airflow and improper cooling that can lead to thermal damage.

1. Power down the server (on page 17).
2. Remove all power:
  - a. Disconnect each power cord from the power source.
  - b. Disconnect each power cord from the server.
3. Do one of the following:
  - Extend the server from the rack (on page 17).
  - Remove the server from the rack (on page 18).
4. Open the access panel latch, slide the access panel to the rear of the chassis, and then remove the access panel.

If the access panel latch is locked, use a T-15 Torx screwdriver to unlock the latch.

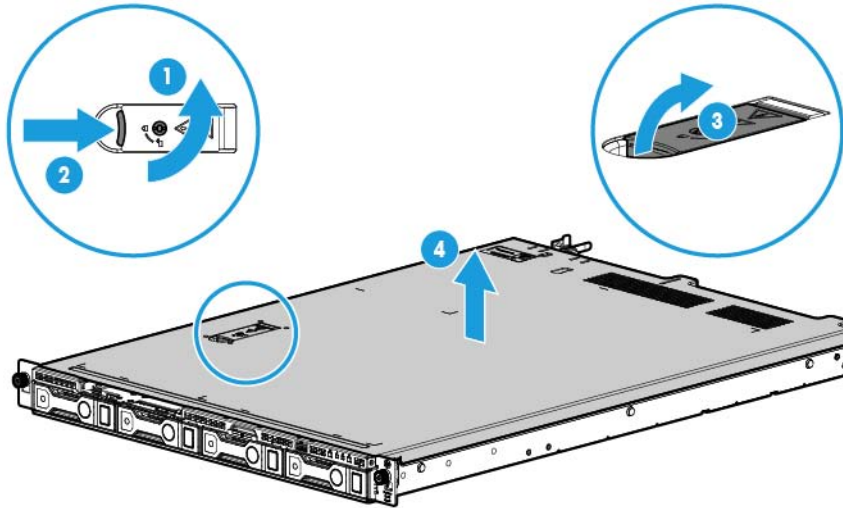

## Install the access panel

1. Place the access panel on top of the server with the access panel latch open. Allow the panel to extend past the rear of the server by approximately 1.25 cm (0.5 inch).
2. Close the access panel latch. The access panel slides to a closed position.
3. Use a T-15 Torx screwdriver to tighten the access panel latch screw.

## Remove the air baffle

**CAUTION:** For proper cooling, do not operate the server without the access panel, baffles, expansion slot covers, or blanks installed. If the server supports hot-plug components, minimize the amount of time the access panel is open.

To remove the component:

1. Power down the server (on page 17).
2. If you are performing a non-hot-plug procedure, remove all power:
  - a. Disconnect each power cord from the power source.
  - b. Disconnect each power cord from the server.
3. Do one of the following:
  - o Extend the server from the rack (on page 17).
  - o Remove the server from the rack (on page 18).
4. Remove the access panel (on page 19).

5. Remove the air baffle.

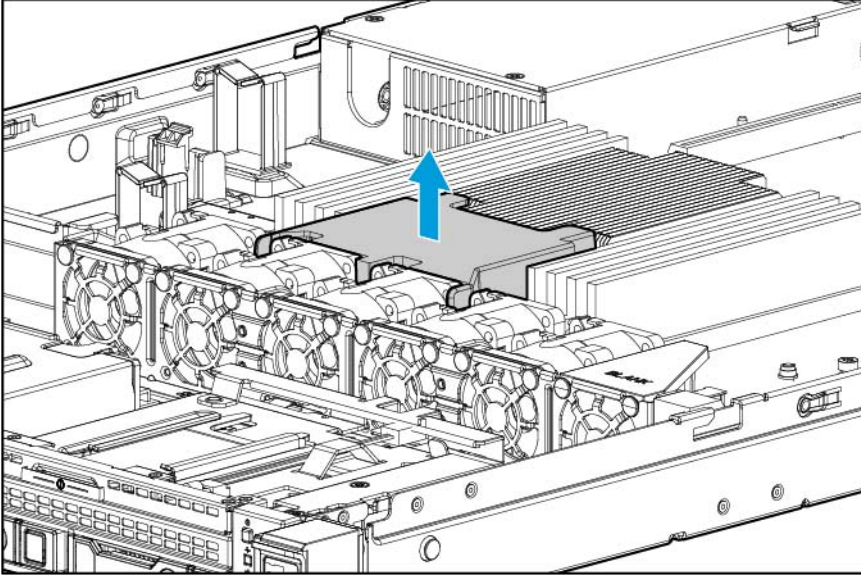

## Install the air baffle

- △ CAUTION:** For proper cooling, do not operate the server without the access panel, baffles, expansion slot covers, or blanks installed. If the server supports hot-plug components, minimize the amount of time the access panel is open.

To install the component:

1. Install the air baffle.

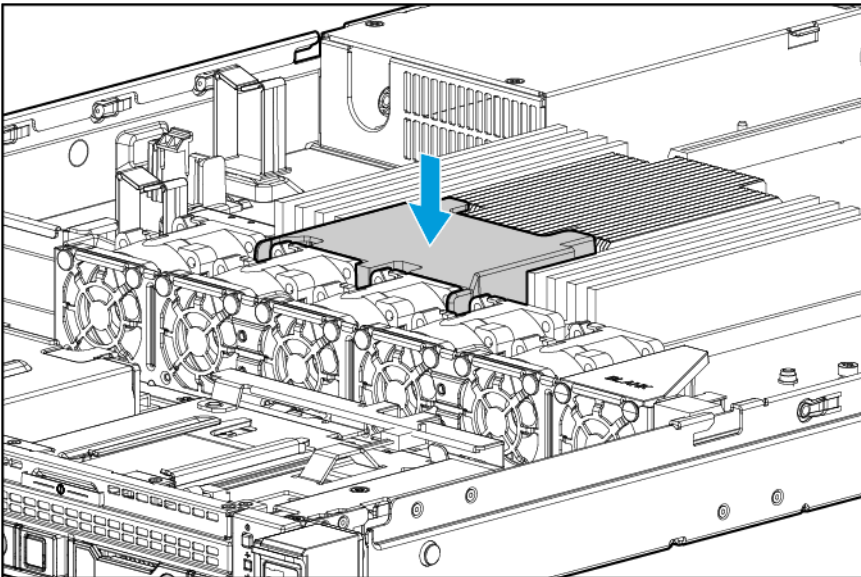

2. Install the access panel (on page 20).
3. Do one of the following:
  - Slide the server into the rack.
  - Install the server into the rack ("Installing the server into the rack" on page 30).

4. Power up the server (on page 17).

## Remove the PCI riser cage

**⚠ CAUTION:** To prevent damage to the server or expansion boards, power down the server, and disconnect all power cords before removing or installing the PCI riser cage.

1. Power down the server (on page 17).
2. Remove all power:
  - a. Disconnect each power cord from the power source.
  - b. Disconnect each power cord from the server.
3. Do one of the following:
  - o Extend the server from the rack (on page 17).
  - o Remove the server from the rack (on page 18).
4. Remove the access panel (on page 19).
5. Disconnect all cables connected to existing expansion boards.
6. Remove the secondary PCI riser cage or PCI blank.
7. Remove any expansion boards installed in the primary riser cage.

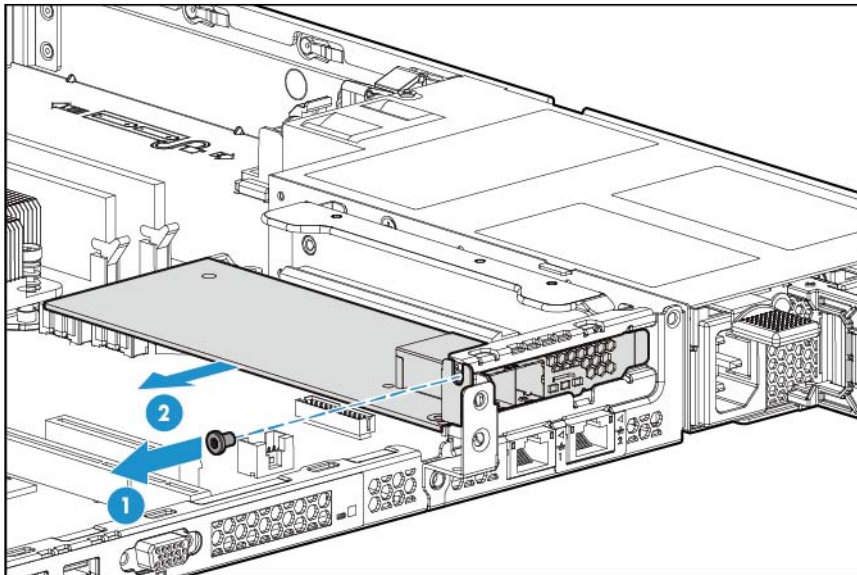

8. Remove the PCI riser cage.

- Primary PCI riser cage

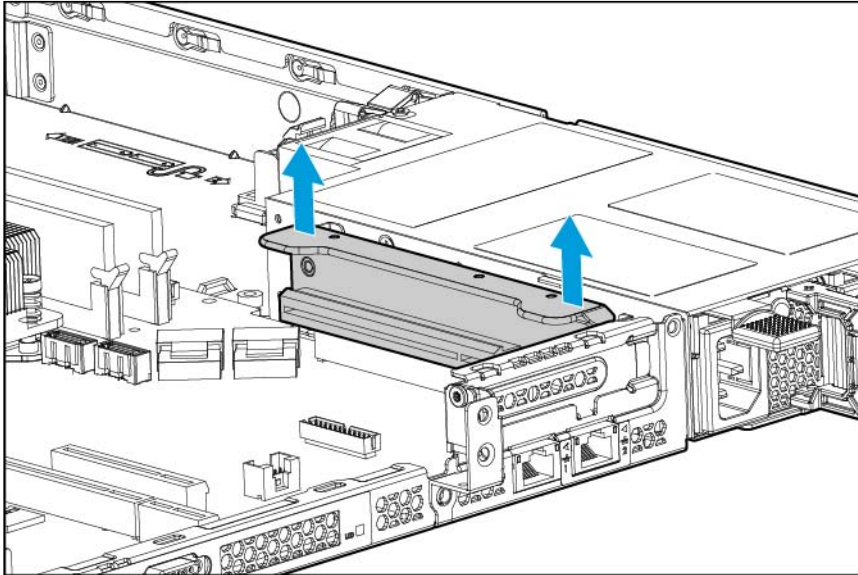

- Secondary PCI riser cage

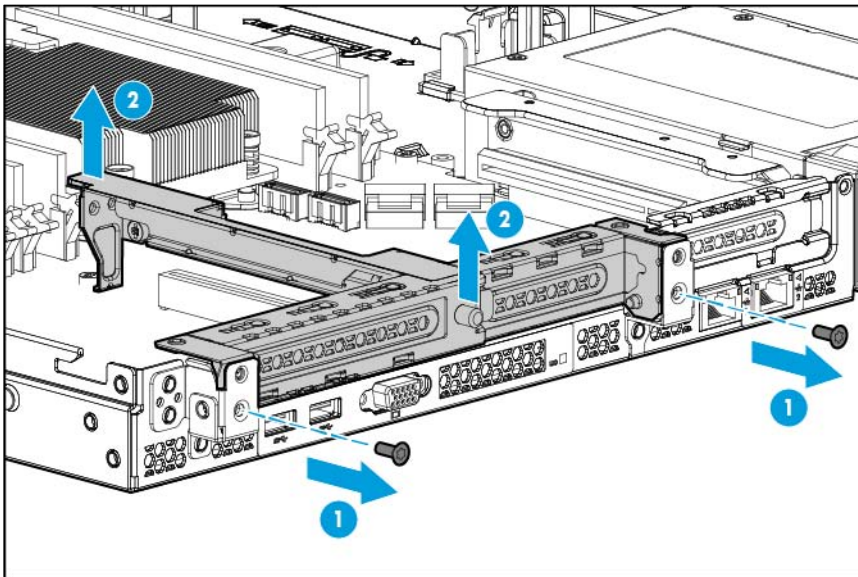

Retain the cage and screws for future use.

## Install the PCI riser cage

△ **CAUTION:** To prevent damage to the server or expansion boards, power down the server, and disconnect all power cords before removing or installing the PCI riser cage.

To install the component:

1. Align the PCI riser board with the corresponding connectors on the system board, and then press down the PCI riser cage.

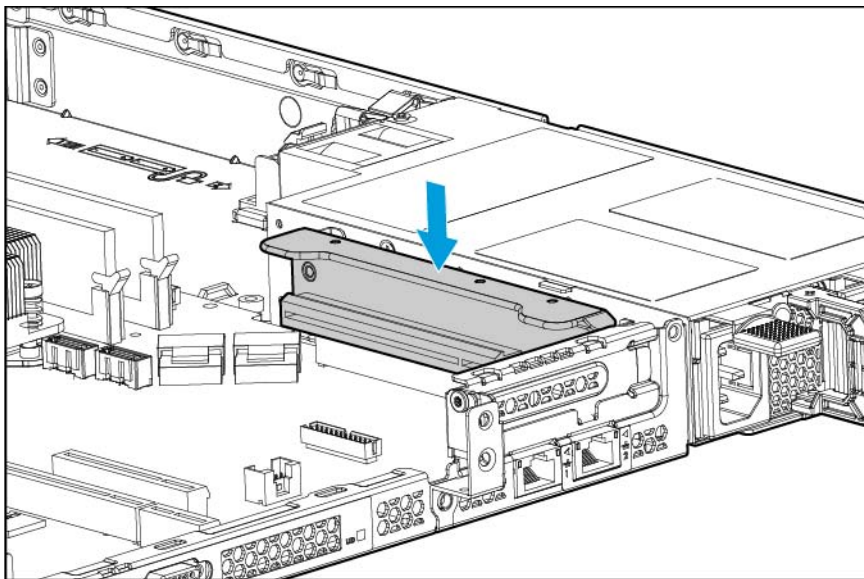

2. If installing the secondary PCI riser cage, remove the PCI blank.

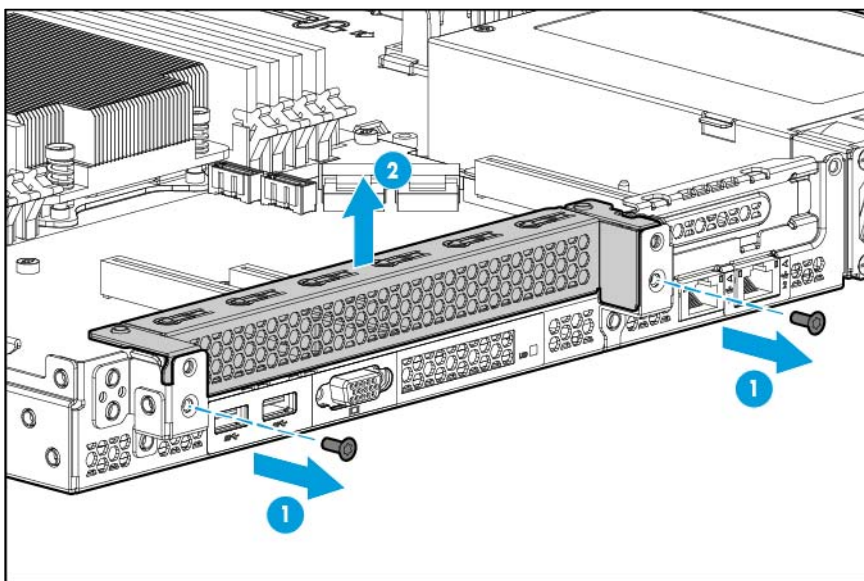

Retain the blank and screws for future use.

3. Align the PCI riser board with the corresponding connectors on the system board, and then press down the PCI riser cage.



4. Tighten the two screws to secure the cage.

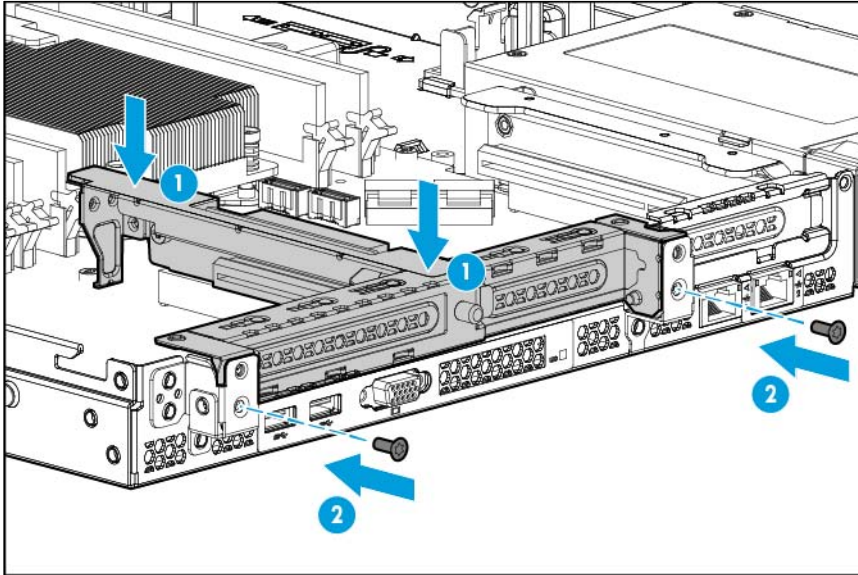

5. Install the access panel (on page 20).
6. Do one of the following:
  - o Slide the server into the rack.
  - o Install the server into the rack ("Installing the server into the rack" on page 30).
7. Power up the server (on page 17).

---

# Setup

## Optional installation services

Delivered by experienced, certified engineers, HP Care Pack services help you keep your servers up and running with support packages tailored specifically for HP ProLiant systems. HP Care Packs let you integrate both hardware and software support into a single package. A number of service level options are available to meet your needs.

HP Care Pack Services offer upgraded service levels to expand your standard product warranty with easy-to-buy, easy-to-use support packages that help you make the most of your server investments. Some of the Care Pack services are:

- Hardware support
  - 6-Hour Call-to-Repair
  - 4-Hour 24x7 Same Day
  - 4-Hour Same Business Day
- Software support
  - Microsoft®
  - Linux
  - HP ProLiant Essentials (HP SIM and RDP)
  - VMware
- Integrated hardware and software support
  - Critical Service
  - Proactive 24
  - Support Plus
  - Support Plus 24
- Startup and implementation services for both hardware and software

For more information on HP Care Pack Services, see the HP website (<http://www.hp.com/services/carepack>).

## Optimum environment

When installing the server in a rack, select a location that meets the environmental standards described in this section.

## Space and airflow requirements

To allow for servicing and adequate airflow, observe the following space and airflow requirements when deciding where to install a rack:

- Leave a minimum clearance of 63.5 cm (25 inches) in front of the rack.
- Leave a minimum clearance of 76.2 cm (30 inches) behind the rack.
- Leave a minimum clearance of 121.9 cm (48 inches) from the back of the rack to the back of another rack or row of racks.

HP servers draw in cool air through the front and expel warm air through the rear. Therefore, the front and rear rack doors must be adequately ventilated to allow ambient room air to enter the cabinet, and the rear door must be adequately ventilated to allow the warm air to escape from the cabinet.

---

 **CAUTION:** To prevent improper cooling and damage to the equipment, do not block the ventilation openings.

---

When vertical space in the rack is not filled by a server or rack component, the gaps between the components might cause changes in airflow through the rack and across the servers. To maintain airflow cover all gaps with blanking panels.

---

 **CAUTION:** Always use blanking panels to fill empty vertical spaces in the rack. This arrangement ensures proper airflow. Using a rack without blanking panels results in improper cooling that can lead to thermal damage.

---

The 9000 and 10000 series racks provide proper server cooling from flow-through perforations in the front and rear doors that provide 64% open area for ventilation.

---

 **CAUTION:** When using a Compaq branded 7000 series rack, install the high airflow rack door insert (PN 327281-B21 for 42U rack, PN 157847-B21 for 22U rack) to provide proper front-to-back airflow and cooling.

---

---

 **CAUTION:** If a third-party rack is used, observe the following additional requirements to ensure adequate airflow and to prevent damage to the equipment:

- Front and rear doors—If the 42U rack includes closing front and rear doors, you must allow 5,350 sq cm (830 sq in) of holes evenly distributed from top to bottom to permit adequate airflow (equivalent to the required 64 percent open area for ventilation).
  - Side—The clearance between the installed rack component and the side panels of the rack must be a minimum of 7 cm (2.75 in).
- 

## Temperature requirements

To ensure continued safe and reliable equipment operation, install or position the system in a well-ventilated, climate-controlled environment.

The maximum recommended ambient operating temperature (TMRA) for most server products is 35°C (95°F). The temperature in the room where the rack is located must not exceed 35°C (95°F).

---

 **CAUTION:** To reduce the risk of damage to the equipment when installing third-party options:

- Do not permit optional equipment to impede airflow around the server or to increase the internal rack temperature beyond the maximum allowable limits.
- Do not exceed the manufacturer's TMRA.

---

## Power requirements

Installation of this equipment must comply with local and regional electrical regulations governing the installation of information technology equipment by licensed electricians. This equipment is designed to operate in installations covered by NFPA 70, 1999 Edition (National Electric Code) and NFPA-75, 1992 (code for Protection of Electronic Computer/Data Processing Equipment). For electrical power ratings on options, refer to the product rating label or the user documentation supplied with that option.



**WARNING:** To reduce the risk of personal injury, fire, or damage to the equipment, do not overload the AC supply branch circuit that provides power to the rack. Consult the electrical authority having jurisdiction over wiring and installation requirements of your facility.



**CAUTION:** Protect the server from power fluctuations and temporary interruptions with a regulating uninterruptible power supply. This device protects the hardware from damage caused by power surges and voltage spikes and keeps the system in operation during a power failure.

When installing more than one server, you might need to use additional power distribution devices to safely provide power to all devices. Observe the following guidelines:

- Balance the server power load between available AC supply branch circuits.
- Do not allow the overall system AC current load to exceed 80% of the branch circuit AC current rating.
- Do not use common power outlet strips for this equipment.
- Provide a separate electrical circuit for the server.

For more information on the hot-plug power supply and calculators to determine server power consumption in various system configurations, see the HP Power Advisor website (<http://www.hp.com/go/hppoweradvisor>).

## Electrical grounding requirements

The server must be grounded properly for proper operation and safety. In the United States, you must install the equipment in accordance with NFPA 70, 1999 Edition (National Electric Code), Article 250, as well as any local and regional building codes. In Canada, you must install the equipment in accordance with Canadian Standards Association, CSA C22.1, Canadian Electrical Code. In all other countries, you must install the equipment in accordance with any regional or national electrical wiring codes, such as the International Electrotechnical Commission (IEC) Code 364, parts 1 through 7. Furthermore, you must be sure that all power distribution devices used in the installation, such as branch wiring and receptacles, are listed or certified grounding-type devices.

Because of the high ground-leakage currents associated with multiple servers connected to the same power source, HP recommends the use of a PDU that is either permanently wired to the building's branch circuit or includes a nondetachable cord that is wired to an industrial-style plug. NEMA locking-style plugs or those complying with IEC 60309 are considered suitable for this purpose. Using common power outlet strips for the server is not recommended.

## Server warnings and cautions

- 
-  **WARNING:** This server is very heavy. To reduce the risk of personal injury or damage to the equipment:
- Observe local occupational health and safety requirements and guidelines for manual material handling.
  - Get help to lift and stabilize the product during installation or removal, especially when the product is not fastened to the rails. HP recommends that a minimum of two people are required for all rack server installations. A third person may be required to help align the server if the server is installed higher than chest level.
  - Use caution when installing the server in or removing the server from the rack; it is unstable when not fastened to the rails.
- 

-  **WARNING:** To reduce the risk of personal injury from hot surfaces, allow the drives and the internal system components to cool before touching them.
- 

-  **WARNING:** To reduce the risk of personal injury, electric shock, or damage to the equipment, remove the power cord to remove power from the server. The front panel Power On/Standby button does not completely shut off system power. Portions of the power supply and some internal circuitry remain active until AC/DC power is removed.
- 

-  **CAUTION:** Protect the server from power fluctuations and temporary interruptions with a regulating uninterruptible power supply. This device protects the hardware from damage caused by power surges and voltage spikes and keeps the system in operation during a power failure.
- 

-  **CAUTION:** Do not operate the server for long periods with the access panel open or removed. Operating the server in this manner results in improper airflow and improper cooling that can lead to thermal damage.
- 

## Rack warnings

- 
-  **WARNING:** To reduce the risk of personal injury or damage to the equipment, be sure that:
- The leveling jacks are extended to the floor.
  - The full weight of the rack rests on the leveling jacks.
  - The stabilizing feet are attached to the rack if it is a single-rack installation.
  - The racks are coupled together in multiple-rack installations.
  - Only one component is extended at a time. A rack may become unstable if more than one component is extended for any reason.
- 

-  **WARNING:** To reduce the risk of personal injury or equipment damage when unloading a rack:
- At least two people are needed to safely unload the rack from the pallet. An empty 42U rack can weigh as much as 115 kg (253 lb), can stand more than 2.1 m (7 ft) tall, and might become unstable when being moved on its casters.
  - Never stand in front of the rack when it is rolling down the ramp from the pallet. Always handle the rack from both sides.
- 

-  **WARNING:** To reduce the risk of personal injury or damage to the equipment, adequately stabilize the rack before extending a component outside the rack. Extend only one component at a time. A rack may become unstable if more than one component is extended.
-



---

**WARNING:** When installing a server in a telco rack, be sure that the rack frame is adequately secured at the top and bottom to the building structure.

---

## Identifying the contents of the server shipping carton

Unpack the server shipping carton and locate the materials and documentation necessary for installing the server. All the rack mounting hardware necessary for installing the server into the rack is included with the rack or the server.

The contents of the server shipping carton include:

- Server
- Power cord
- Rack rail hook-and-loop strap
- Printed setup documentation
- Rack mounting hardware kit and documentation (optional)

You need the following items for some procedures:

- T-25 Torx screwdriver (to loosen the shipping screws located inside the server quick-release latch rack ears)
- T-10/T-15 Torx screwdriver
- Hardware options
- Operating system or application software

## Installing hardware options

Install any hardware options before initializing the server. For options installation information, see the option documentation. For server-specific information, see "Hardware options installation (on page 37)."

## Installing the server into the rack

To install the server into a rack with square, round, or threaded holes, refer to the instructions that ship with the rack hardware kit.

If you are installing the server into a telco rack, order the appropriate option kit at the RackSolutions.com website (<http://www.racksolutions.com/hp>). Follow the server-specific instructions on the website to install the rack brackets.

- 
- ⚠ WARNING:** This server is very heavy. To reduce the risk of personal injury or damage to the equipment:
- Observe local occupational health and safety requirements and guidelines for manual material handling.
  - Get help to lift and stabilize the product during installation or removal, especially when the product is not fastened to the rails. HP recommends that a minimum of two people are required for all rack server installations. A third person may be required to help align the server if the server is installed higher than chest level.
  - Use caution when installing the server in or removing the server from the rack; it is unstable when not fastened to the rails.
- 
- ⚠ CAUTION:** Always plan the rack installation so that the heaviest item is on the bottom of the rack. Install the heaviest item first, and continue to populate the rack from the bottom to the top.
- 

To install the server in an HP, Compaq-branded, Telco, or a third-party rack:

1. Install the server and cable management arm option into the rack. See the documentation that ships with the Easy Install Rail Kit.
2. Connect peripheral devices to the server. For information on identifying connectors, see "Rear panel components (on page 10)."

- 
- ⚠ WARNING:** To reduce the risk of electric shock, fire, or damage to the equipment, do not plug telephone or telecommunications connectors into RJ-45 connectors.
- 

For a server using a non-hot-plug power supply:

3. To prevent the accidental disconnection of the power cord when sliding the rack into and from the rack, secure the power cord through the strain relief clip:
  - a. If the clip is positioned too near the power cord that it blocks the power cord plug connection, slide the clip backward.

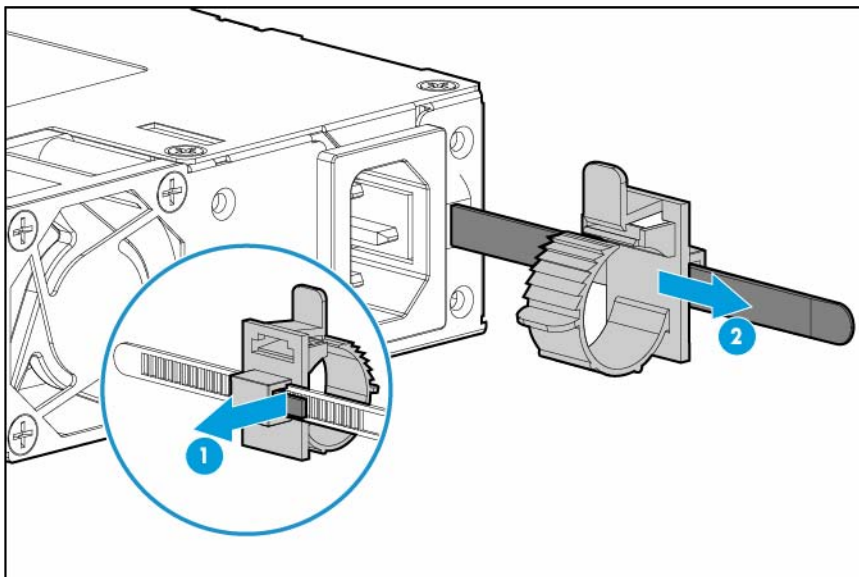

- b. Connect the power cord to the server.
- c. Press the top part of the clip, and then pull the clip open.

- d. Position the power cord inside the clip, and then close the clip.

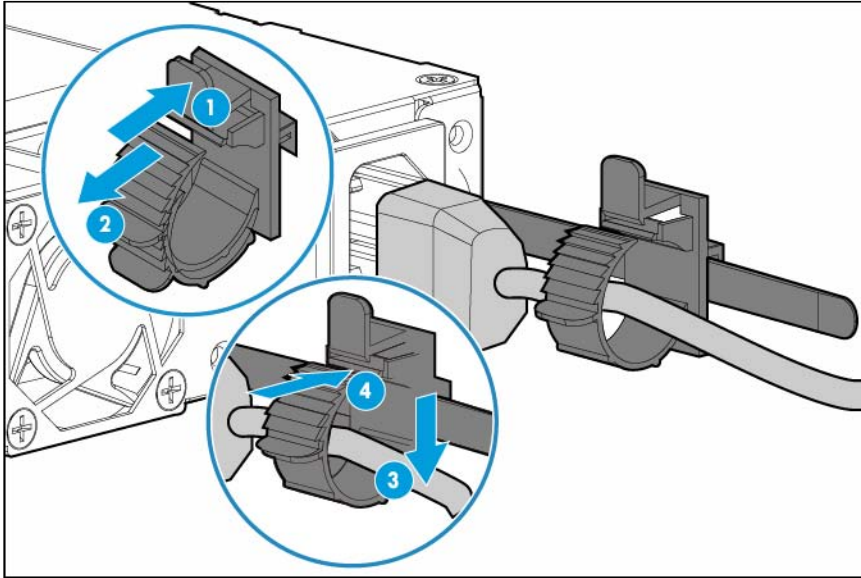

- e. Slide the clip forward until it is flush against the edge of the power cord plug.

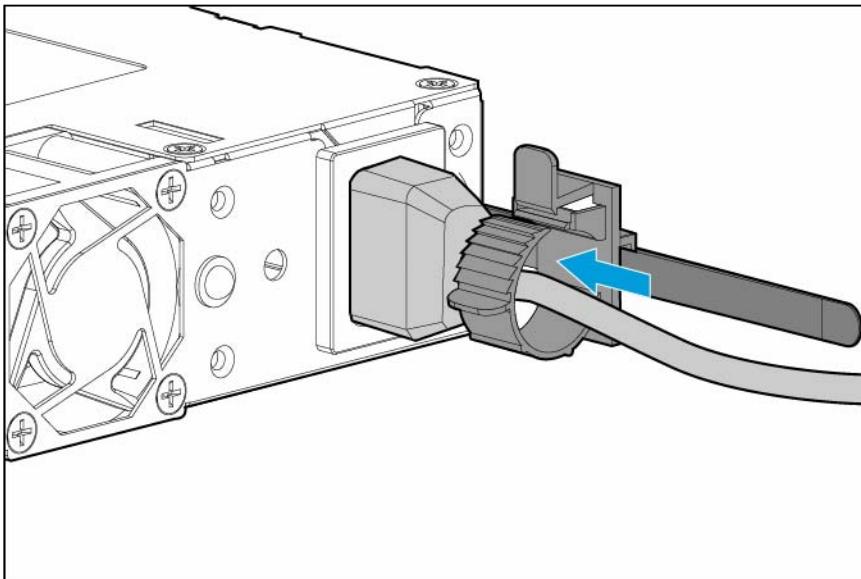

For a server using a hot-plug power supply:

4. To prevent accidental power cord disconnection when sliding the server in and out of the rack, secure the power cord in the hook-and-loop strap attached to the power input module handle:
- a. Unwrap the hook-and-loop strap from the power input module handle.

**CAUTION:** Avoid tight bend radii to prevent damaging the internal wires of a power cord or a server cable. Never bend power cords and server cables tight enough to cause a crease in the sheathing.



- b. Bend the plug end of the power cord in the position shown in the following image.

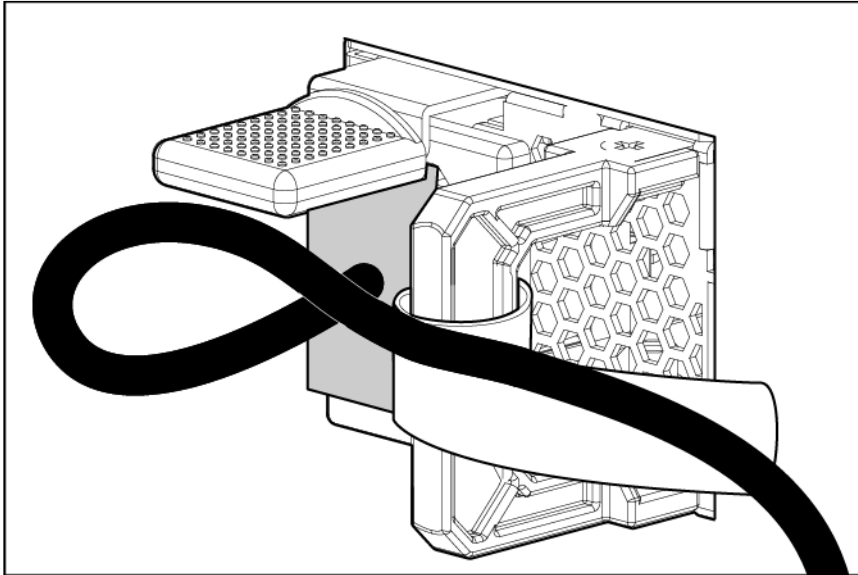

- c. Secure the power cord in the hook-and-loop strap as shown in the following image.

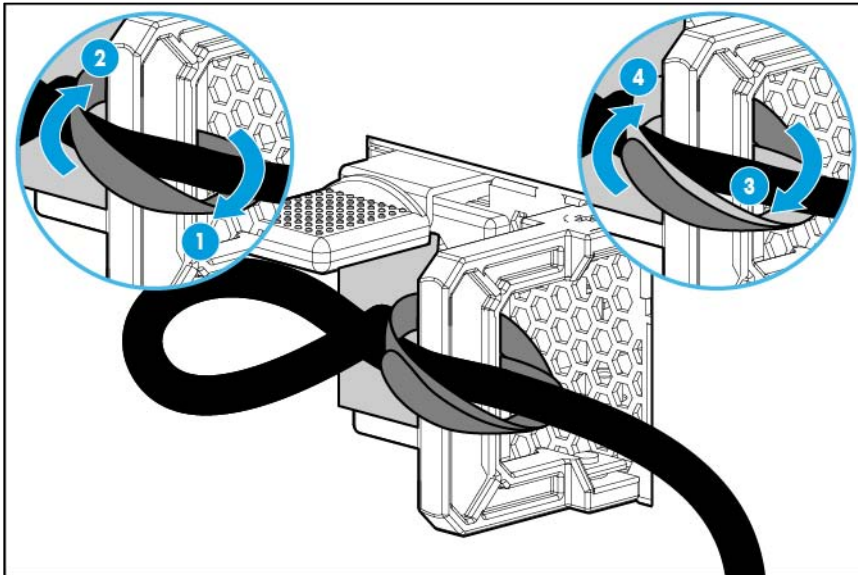

5. Employ best practices to route and manage the power cords and other cables in the server rear panel.



**IMPORTANT:** When using cable management arm components, be sure to leave enough slack in each of the cables to prevent damage to the cables when the server is extended from the rack.

6. Use the hook-and-loop strap included in the server shipping carton to secure the power cords and the other rear panel cables to the rack rail. For detailed instructions, see "Installing the rack rail hook-and-loop strap (on page 34)."
7. Connect the power cord to the power source.



**WARNING:** To reduce the risk of electric shock or damage to the equipment:

- Do not disable the power cord grounding plug. The grounding plug is an important safety feature.
- Plug the power cord into a grounded (earthed) electrical outlet that is easily accessible at all times.
- Unplug the power cord from the power supply to disconnect power to the equipment.
- Do not route the power cord where it can be walked on or pinched by items placed against it. Pay particular attention to the plug, electrical outlet, and the point where the cord extends from the server.

## Installing the rack rail hook-and-loop strap

The rack rail hook-and-loop strap can be installed on either the left or right rack rail. HP recommends installing it on the left rack rail for better cable management.

To install the rack rail hook-and-loop strap:

1. Install the server into the rack ("Installing the server into the rack" on page 30).
2. Install the rack rail hook-and-loop strap:
  - a. Hold the rear panel cables against the rack rail, and then wrap the strap around the rack rail.



**CAUTION:** To prevent thermal or mechanical obstruction on full-length servers installed in the rack, the extra length and buckle part of the strap must be facing the outside of the rack rail.

- b. Loop the end of the hook-and-loop strap through the buckle.

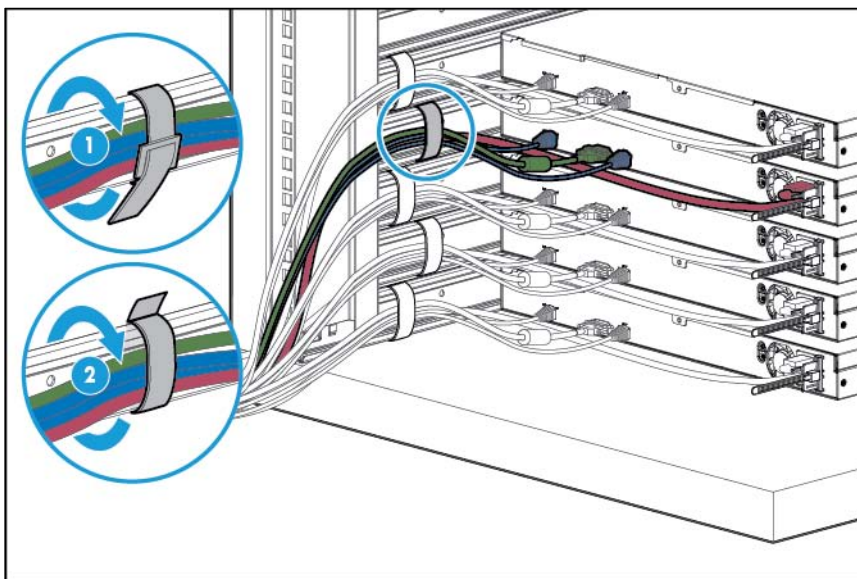

When multiple hook-and-loop straps are used in the same rack, stagger the strap location, so that the straps are adjacent to each other when viewed from top to bottom. This positioning will enable the rack rail to slide easily in and out of the rack.

## Powering on and selecting boot options

1. Connect the Ethernet cable.

2. Press the Power On/Standby button.
3. During the initial boot:
  - To modify the server configuration ROM default settings, press **F9** when prompted from the start up sequence to enter the HP UEFI System Utilities. By default, the HP UEFI System Utilities runs in the English language.
  - If you do not need to modify the server configuration and are ready to install the system software, press **F10** to access Intelligent Provisioning.

---

**NOTE:** If an HP Smart Array controller has been added or is embedded in the system, the controller defaults to a RAID configuration based on the size and number of drives installed. For more information on modifying the controller default settings, see the documentation in the HP website.

---

For more information on automatic configuration, see the *HP UEFI System Utilities User Guide for HP ProLiant Gen9 Servers* on the HP website (<http://www.hp.com/go/ProLiantUEFI/docs>).

## Installing the operating system

This HP ProLiant server does not ship with provisioning media. Everything needed to manage and install the system software and firmware is preloaded on the server.

To operate properly, the server must have a supported operating system. For the latest information on operating system support, see the HP website (<http://www.hp.com/go/supportos>).

To install an operating system on the server, use one of the following methods:

- Intelligent Provisioning—iLO contains Intelligent Provisioning for embedded deployment, updating, and provisioning capabilities. Intelligent Provisioning can configure the server and install an operating system.

To install an operating system on the server with Intelligent Provisioning (local or remote):

- a. Connect the Ethernet cable between the network connector on the server and a network jack.
  - b. Press the Power On/Standby button.
  - c. During server POST, press **F10**.
  - d. Complete the initial Preferences and Registration portion of Intelligent Provisioning (on page 88).
  - e. At the 1 Start screen, click **Configure and Install**.
  - f. To finish the installation, follow the onscreen prompts. An Internet connection is required to update the firmware and systems software.
- Remote deployment installation—To deploy an operating system remotely, use Insight Control Server Provisioning for an automated solution.

For additional system software and firmware updates, download the HP Service Pack for ProLiant from the HP website (<http://www.hp.com/go/spp/download>). Software and firmware must be updated before using the server for the first time, unless any installed software or components require an older version. For more information, see "Keeping the system current (on page 95)."

For more information on using these installation methods, see the HP website (<http://www.hp.com/go/ilo>).



# Registering the server

To experience quicker service and more efficient support, register the product at the HP Product Registration website (<http://register.hp.com>).

# Hardware options installation

## Introduction

If more than one option is being installed, read the installation instructions for all the hardware options and identify similar steps to streamline the installation process.

-  **WARNING:** To reduce the risk of personal injury from hot surfaces, allow the drives and the internal system components to cool before touching them.
-  **CAUTION:** To prevent damage to electrical components, properly ground the server before beginning any installation procedure. Improper grounding can cause electrostatic discharge.

## Security bezel option

The security bezel is only supported in servers using the quick-release latch rack ears.

Install the security bezel and then lock it with the key provided with the kit.

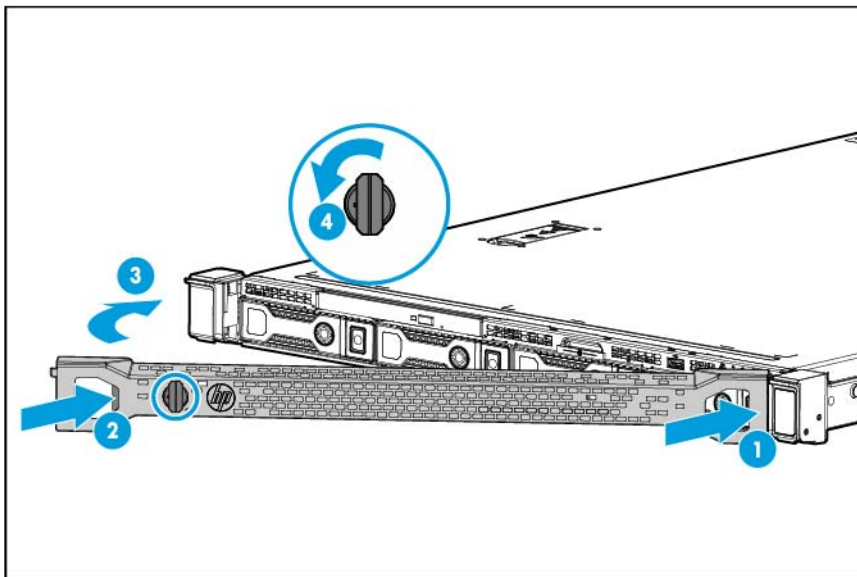

## Drive options

The server supports up to four LFF hot-plug or non hot-plug drives or up to 8 SFF hot-plug drives.

The embedded storage controller supports SATA devices.



---

**IMPORTANT:** The boot order settings, firmware versions, and any additional HP software, including the HP Smart Array SAS license key, are stored in the system board. Transfer this information to the new system board to ensure normal server operation when the system board is replaced.

---

For more information about product features, specifications, options, configurations, and compatibility, see the product QuickSpecs on the HP website (<http://www.hp.com/go/qs>).

## Drive installation guidelines

When adding drives to the server, observe the following general guidelines:

- The system automatically sets all device numbers.
- Populate drive bays, based on the drive numbering sequence. Start from the drive bay with the lowest device number.
- All drives grouped into the same drive array must meet the following criteria:
  - They must be either all SAS or all SATA.
  - They must be either all hard drives or all solid state drives.
  - For the most efficient use of drive space, the drives must have approximately the same capacity. Each configuration utility treats every physical drive in an array as if it has the same capacity as the smallest drive in the array. Any excess capacity of a particular drive cannot be used in the array and so is unavailable for data storage.

## Installing a non-hot-plug drive



---

**CAUTION:** To prevent improper cooling and thermal damage, do not operate the server unless all bays are populated with either a component or a blank.

---

To install the component:

1. Power down the server (on page 17).
2. Remove all power:
  - a. Disconnect each power cord from the power source.
  - b. Disconnect each power cord from the server.
3. If installed, remove the security bezel ("[Remove the security bezel \(optional\)](#)" on page 18).
4. Remove the drive carrier.

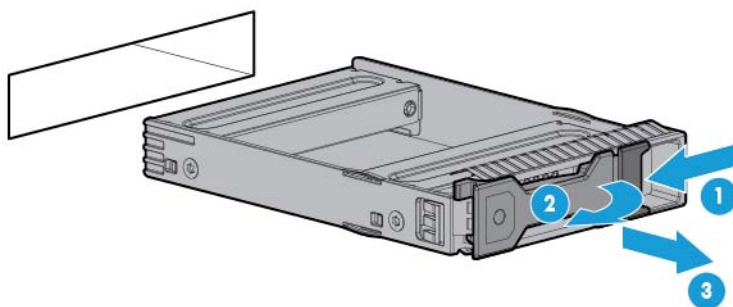

5. Remove the two metal brackets from the drive carrier.

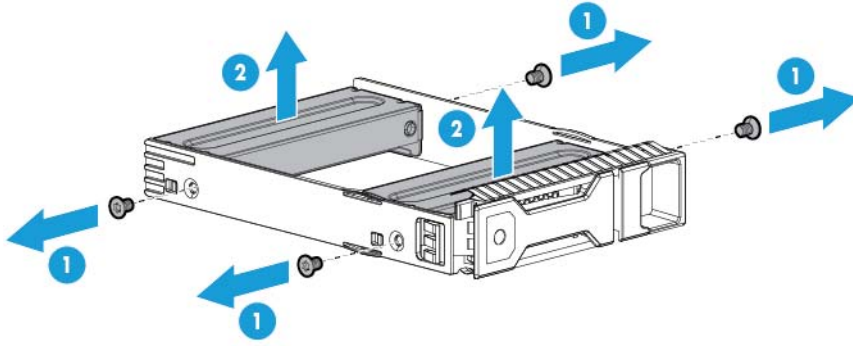

6. Install the drive in the carrier.

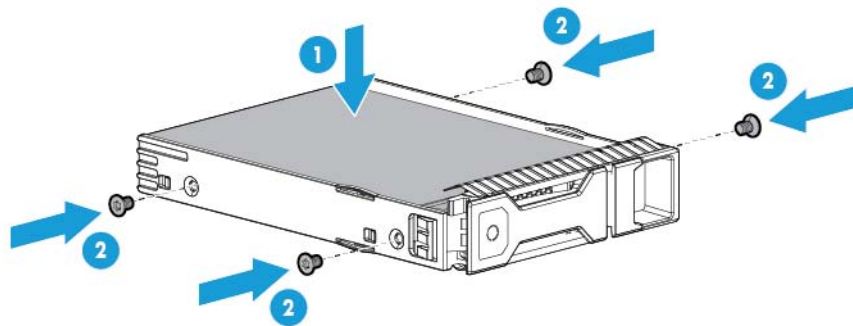

7. Install the drive.

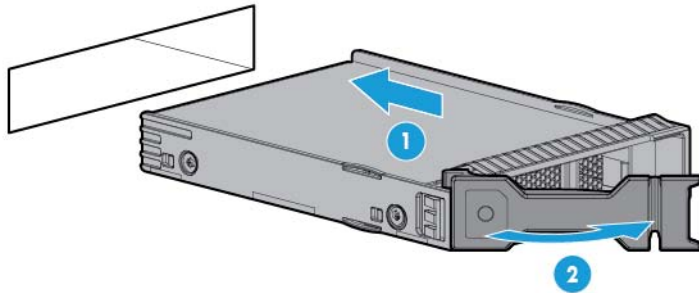

**CAUTION:** To prevent improper cooling and thermal damage, do not operate the server unless all bays are populated with either a component or a blank.

8. If removed, install the security bezel.
9. Connect each power cord to the server.
10. Connect each power cord to the power source.
11. Power up the server (on page 17).

To configure arrays, see the *HP Smart Storage Administrator User Guide* on the HP website (<http://www.hp.com/go/smartstorage/docs>).

# Installing a hot-plug drive

**CAUTION:** To prevent improper cooling and thermal damage, do not operate the server unless all bays are populated with either a component or a blank.

To install the component:

1. If installed, remove the security bezel ("[Remove the security bezel \(optional\)](#)" on page 18).
2. Remove the drive blank.

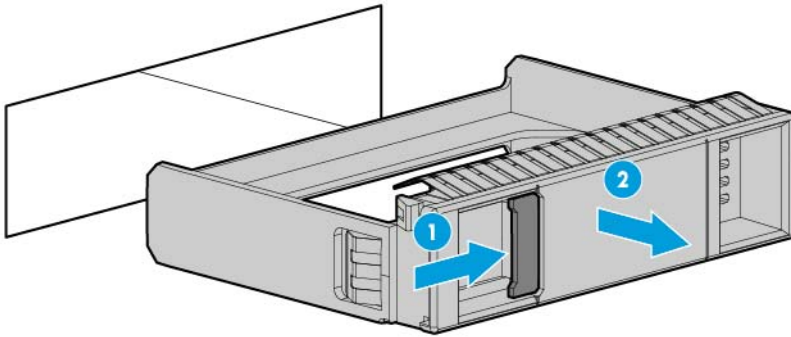

3. Prepare the drive.

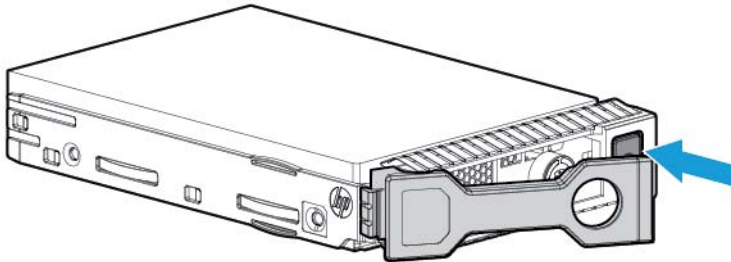

4. Install the drive.

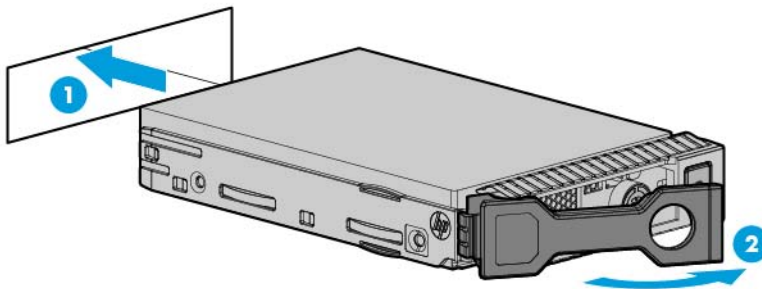

5. Determine the status of the drive from the drive LED definitions ("[Hot-plug drive LED definitions](#)" on page 14).
6. If removed, install the security bezel.



To configure arrays, see the *HP Smart Storage Administrator User Guide* on the HP website (<http://www.hp.com/go/smartstorage/docs>).

## Drive cable options

Use these drive cable options to install an HP Host Bus Adapter or an HP Smart Array Controller board option.

For more information about product features, specifications, options, configurations, and compatibility, see the product QuickSpecs on the HP website (<http://www.hp.com/go/qs>).

## Mini-SAS cable options

To connect the cable option:

1. Power down the server (on page 17).
2. Remove all power:
  - a. Disconnect each power cord from the power source.
  - b. Disconnect each power cord from the server.
3. Do one of the following:
  - o Extend the server from the rack (on page 17).
  - o Remove the server from the rack (on page 18).
4. Remove the access panel (on page 19).
5. Remove the secondary PCI riser cage ("Remove the PCI riser cage" on page 22).
6. Remove the baffle from the controller board.
7. Disconnect the existing Mini-SAS cables from the system board and the drive backplane.
8. If you intend to use a cache module and a HP Smart Storage Battery, install these options now. ("Controller options" on page 44)
9. Install the storage controller ("Expansion board options" on page 63).  
H240 and P440 boards can only be installed in slot 1.
10. Connect the common end of the Mini-SAS cable to the controller option.

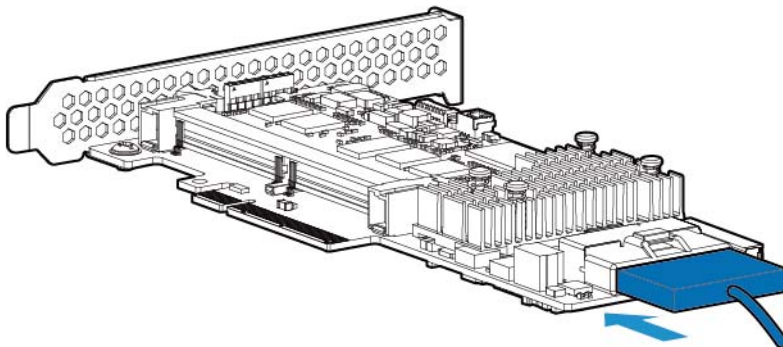

11. Install the secondary PCI riser cage.

12. Route the Mini-SAS cables alongside the system board and connect the connectors to the drive backplane.
- o H240 Host Bus Adapter to the 4 LFF drive backplane

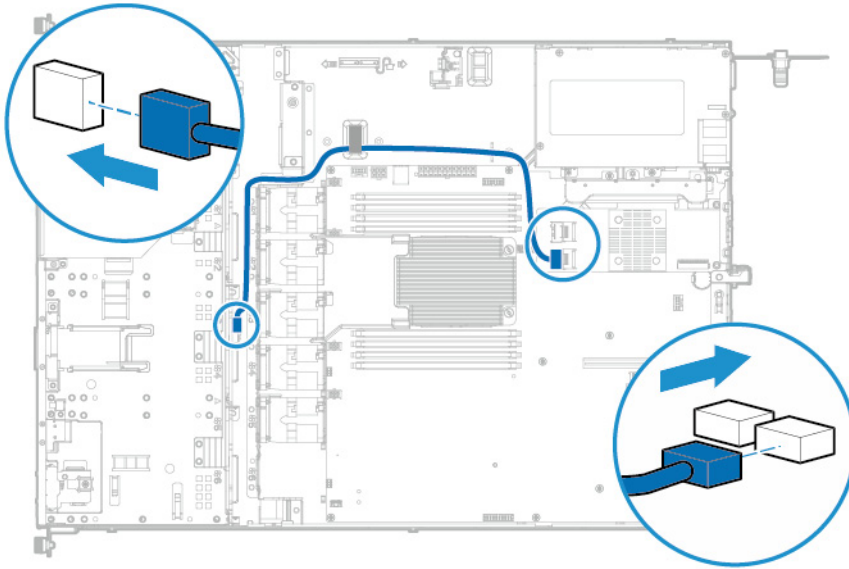

- o H240 Host Bus Adapter to the 8 SFF drive backplane

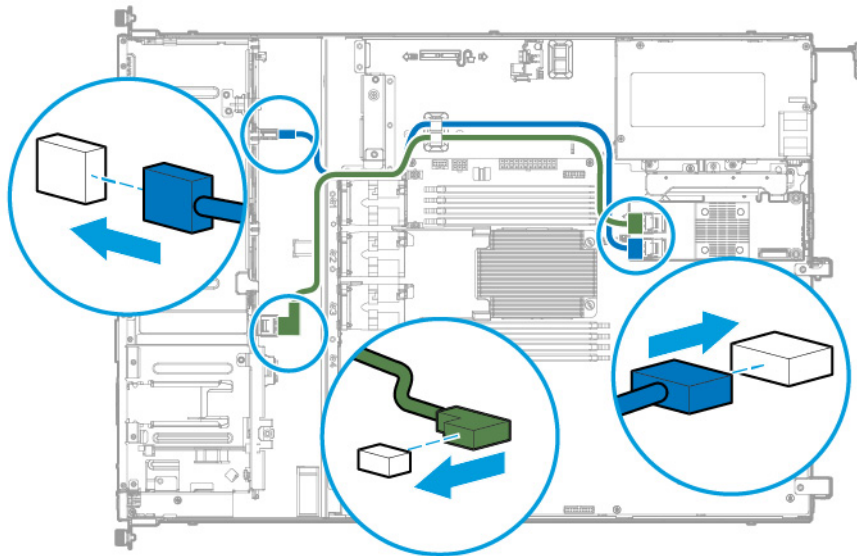

- P440 Smart Array Controller to the 4 LFF drive backplane

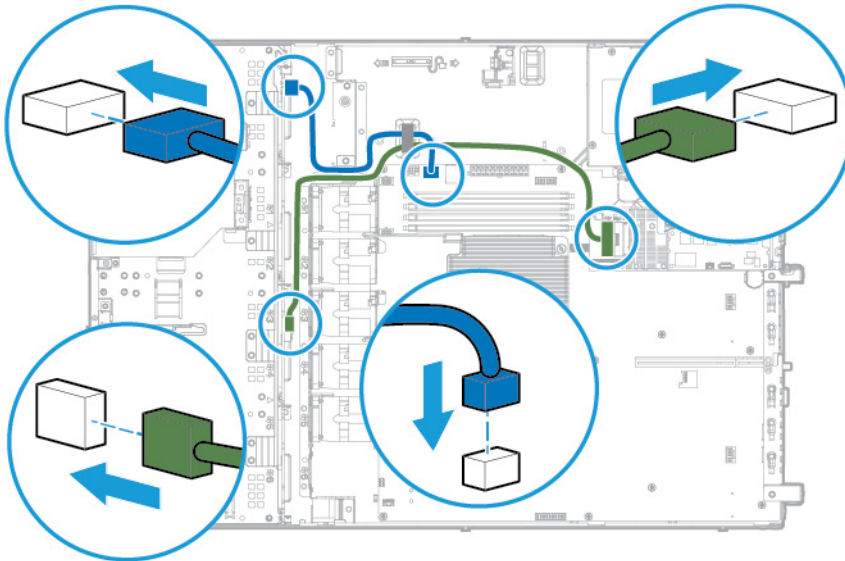

- P440 Smart Array Controller to the 8 SFF drive backplane

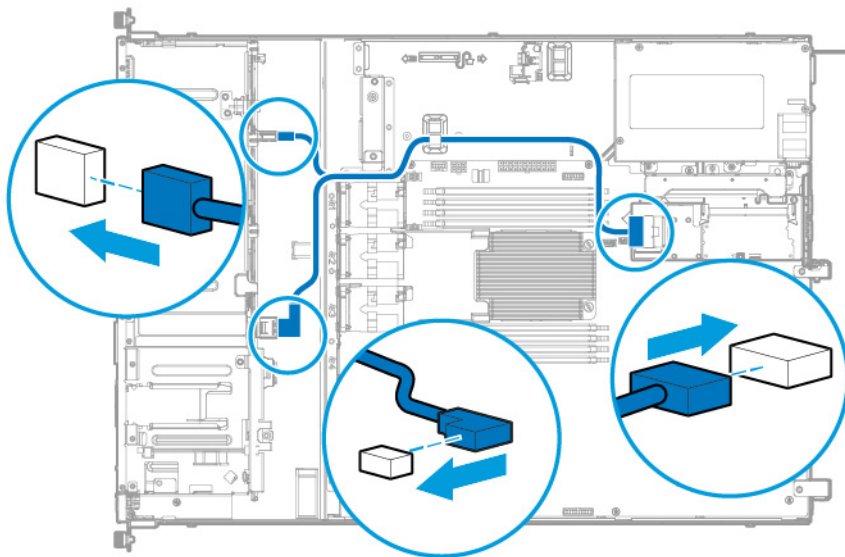

13. Connect the rest of the drive cables required in this drive configuration. For more information, see "Storage cabling (on page 75)."
14. Install the access panel (on page 20).
15. Install the server into the rack ("Installing the server into the rack" on page 30).
16. Power up the server (on page 17).

**CAUTION:** To prevent improper cooling and thermal damage, do not operate the server unless all bays are populated with either a component or a blank.

17. Install the drives ("Drive options" on page 37).

# Controller options

The server ships with an embedded HP Dynamic Smart Array B140i Controller. For more information about the controller and its features, see the *HP Dynamic Smart Array B140i RAID Controller User Guide* on the HP website (<http://www.hp.com/go/smartstorage/docs>).

Upgrade options exist for an integrated array controller. For a list of supported options, see the product QuickSpecs on the HP website (<http://www.hp.com/go/qs>).

To configure arrays, see the *HP Smart Storage Administrator User Guide* on the HP website (<http://www.hp.com/go/smartstorage/docs>).

The server supports FBWC. FBWC consists of a cache module and an HP Smart Storage Battery Pack. The DDR cache module buffers and stores data being written by an integrated Gen9 P-series Smart Array Controller.

This server supports the 96-W HP Smart Storage Battery Pack. This battery pack can support up to 24 devices. Devices in this context refer to the HP Smart Array Controller or NVDIMM associated with the cache module.

The battery pack might have a low charge when installed. If the battery does have low charge, a POST error message appears when the server is powered up, indicating that the battery pack is temporarily disabled. No action is necessary. The internal circuitry automatically recharges the batteries and enables the battery pack. When the system is powered on this process might take approximately 2 hours.

If a system power failure occurs, a fully charged battery pack provides power for up to 150 seconds. During that interval, the controller transfers the cached data from DDR memory to flash memory, where the data remains indefinitely or until a controller retrieves the data. The data protection and the time limit also apply if a power outage occurs. When power is restored to the system, an initialization process writes the preserved data to the storage drives.

- 
-  **CAUTION:** The cache module connector does not use the industry-standard DDR3 mini-DIMMs. Do not use the controller with cache modules designed for other controller models, because the controller can malfunction and you can lose data. Also, do not transfer this cache module to an unsupported controller model, because you can lose data.

---

  -  **CAUTION:** To prevent a server malfunction or damage to the equipment, do not add or remove the battery pack while an array capacity expansion, RAID level migration, or stripe size migration is in progress.

---

  -  **CAUTION:** After the server is powered down, wait for 30 seconds, and then check the amber LED before unplugging the cable from the cache module. If the amber LED flashes after 30 seconds, do not remove the cable from the cache module. The cache module is backing up data. Data will be lost if the cable is detached when the amber LED is still flashing.
- 

## Installing a storage controller and FBWC module

Install H240 and P440 cards in slot 1 of the primary PCI riser cage.

For more information about product features, specifications, options, configurations, and compatibility, see the product QuickSpecs on the HP website (<http://www.hp.com/go/qs>).

- 
-  **IMPORTANT:** For additional installation and configuration information, see the documentation that ships with the option.
-

To install the component:

1. Power down the server (on page 17).
2. Remove all power:
  - a. Disconnect each power cord from the power source.
  - b. Disconnect each power cord from the server.
3. Do one of the following:
  - o Extend the server from the rack (on page 17).
  - o Remove the server from the rack (on page 18).
4. Remove the access panel (on page 19).
5. Remove the secondary PCI riser cage. ("[Remove the PCI riser cage](#)" on page 22)

---

**CAUTION:** When connecting or disconnecting the cache module cable, the connectors on the cache module and cable are susceptible to damage. Avoid excessive force and use caution to avoid damage to these connectors.

---

6. If you intend to use an FBWC module, install the module on the storage controller. Depending on the controller model, the cable connector on the cache module might be facing up or down when the module is installed on the controller board.
  - a. Connect the cache module backup power cable to the module.

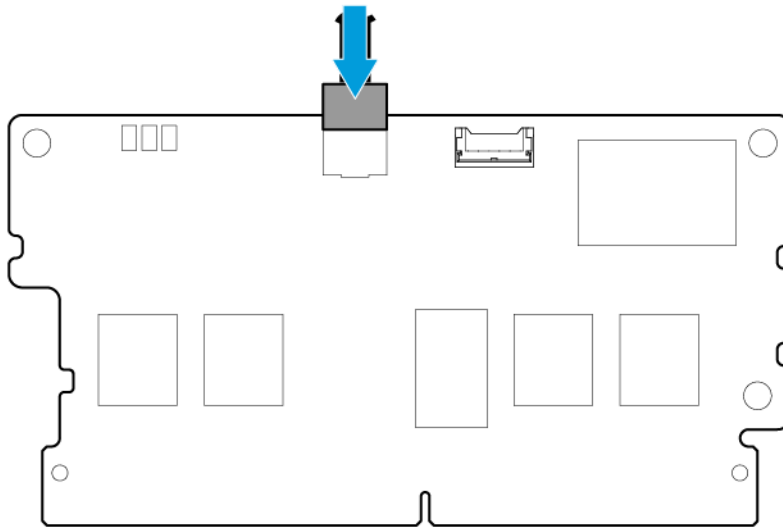

- b. Install the cache module on the storage controller.

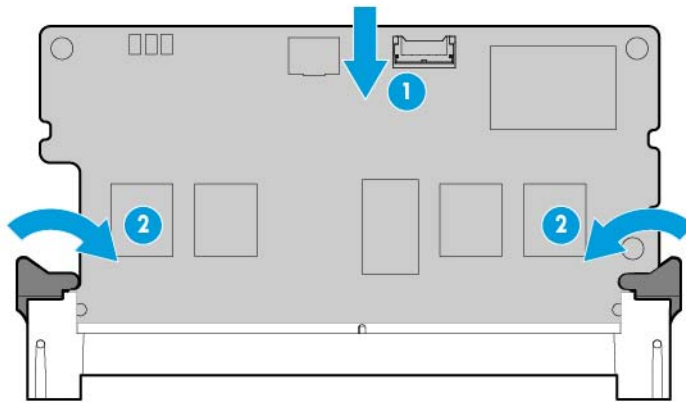

7. Install the storage controller.  
H240 and P440 cards can only be installed in slot 1 of the primary PCI riser cage.
8. If you installed a cache module on the storage controller, connect the cache module cable to the system board connector. For cache module cabling information, see "FBWC cabling (on page 79)".
9. Connect all necessary internal cables to the storage controller. For internal drive cabling information, see "Storage cabling (on page 75)."
10. If you are planning to install an HP Smart Storage Battery Pack, install it now ("Installing the battery pack" on page 46).
11. Install the secondary PCI riser cage. ("Install the PCI riser cage" on page 23)
12. Install the access panel (on page 20).
13. Do one of the following:
  - o Slide the server into the rack.
  - o Install the server into the rack ("Installing the server into the rack" on page 30).
14. Power up the server (on page 17).
15. If you are planning to install new drives, install them now ("Drive options" on page 37).

For more information about the integrated storage controller and its features, select the relevant user documentation on the HP website (<http://www.hp.com/go/smartstorage/docs>).

To configure arrays, see the *HP Smart Storage Administrator User Guide* on the HP website (<http://www.hp.com/go/smartstorage/docs>).

## Installing the battery pack

For more information about product features, specifications, options, configurations, and compatibility, see the product QuickSpecs on the HP website (<http://www.hp.com/go/qs>).

**CAUTION:** In systems that use external data storage, be sure that the server is the first unit to be powered down and the last to be powered back up. Taking this precaution ensures that the system does not erroneously mark the external drives as failed when the server is powered up.

To install the component:

1. Power down the server (on page 17).

2. Remove all power:
  - a. Disconnect each power cord from the power source.
  - b. Disconnect each power cord from the server.
3. Do one of the following:
  - o Extend the server from the rack (on page 17).
  - o Remove the server from the rack (on page 18).
4. Remove the access panel (on page 19).
5. Install the HP Smart Storage Battery:

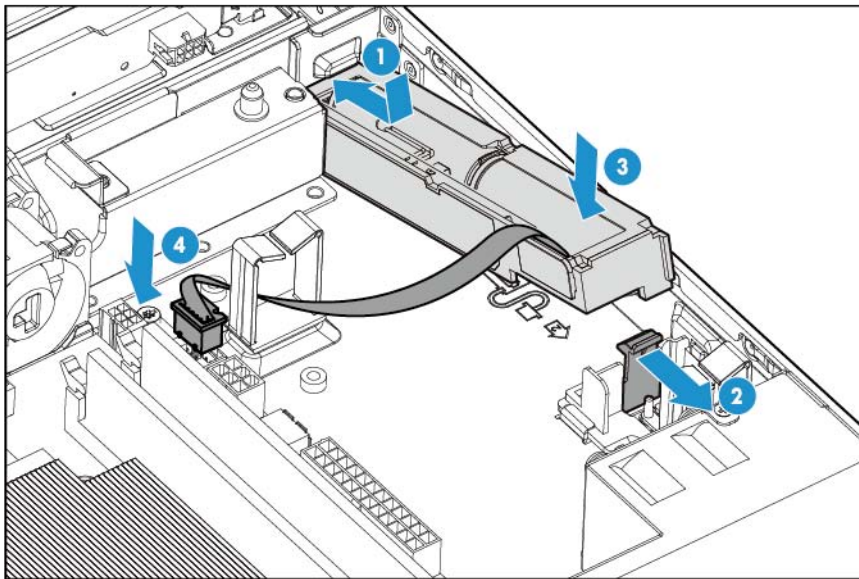

6. Install the access panel (on page 20).
7. Do one of the following:
  - o Slide the server into the rack.
  - o Install the server into the rack ("Installing the server into the rack" on page 30).
8. Power up the server (on page 17).

## Optical drive option

For more information about product features, specifications, options, configurations, and compatibility, see the product QuickSpecs on the HP website (<http://www.hp.com/go/qs>).

To install the component:

1. Power down the server (on page 17).
2. Remove all power:
  - a. Disconnect each power cord from the power source.
  - b. Disconnect each power cord from the server.
3. Do one of the following:
  - o Extend the server from the rack (on page 17).
  - o Remove the server from the rack (on page 18).

4. Remove the access panel (on page 19).
5. Remove the optical drive blank
  - o Four-bay LFF configuration

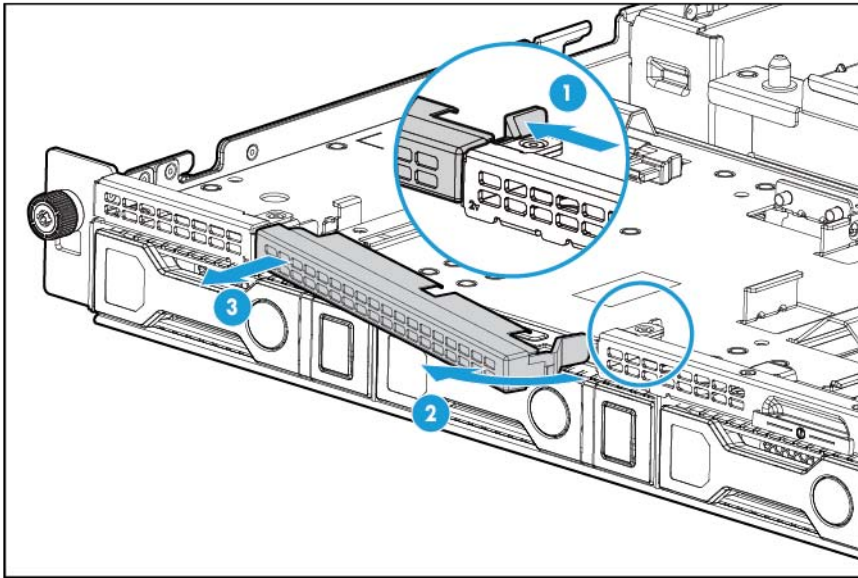

- o Eight-bay SFF configuration

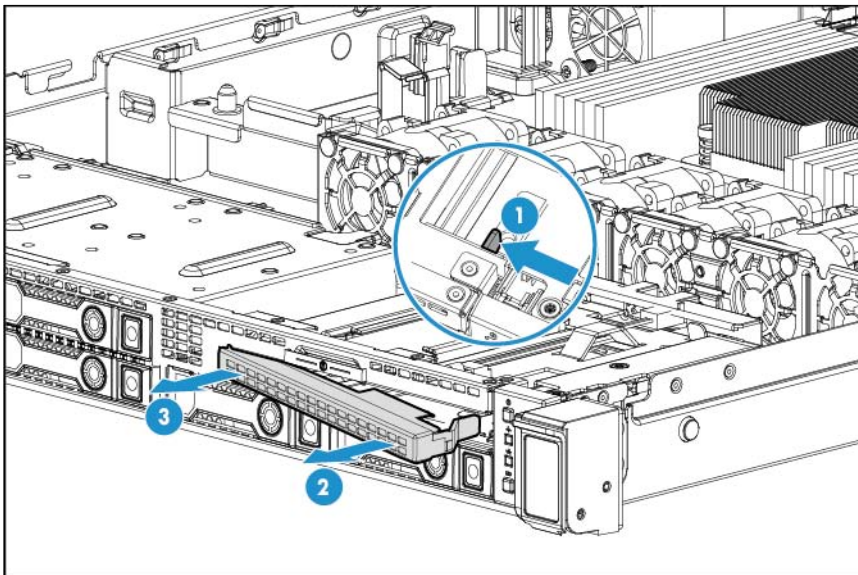

6. Install the optical drive into the bay.



- Four-bay LFF configuration

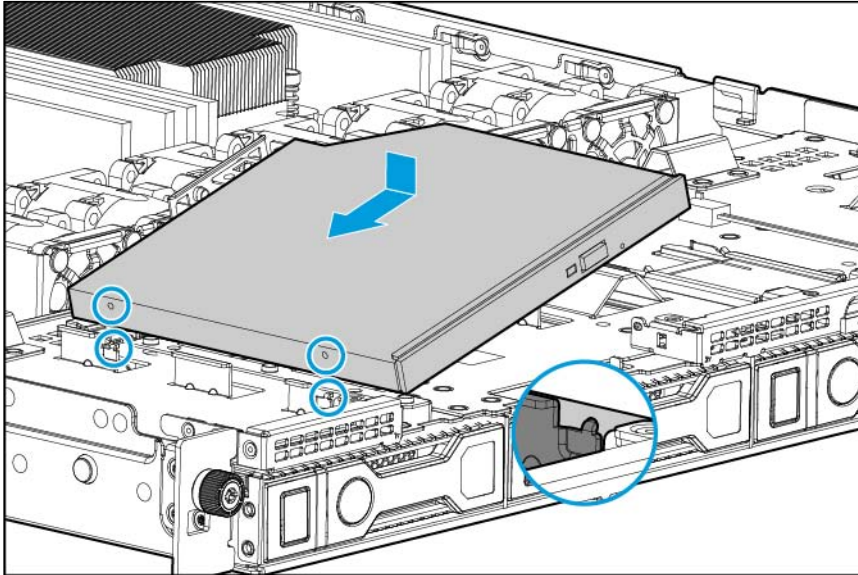

- Eight-bay SFF configuration

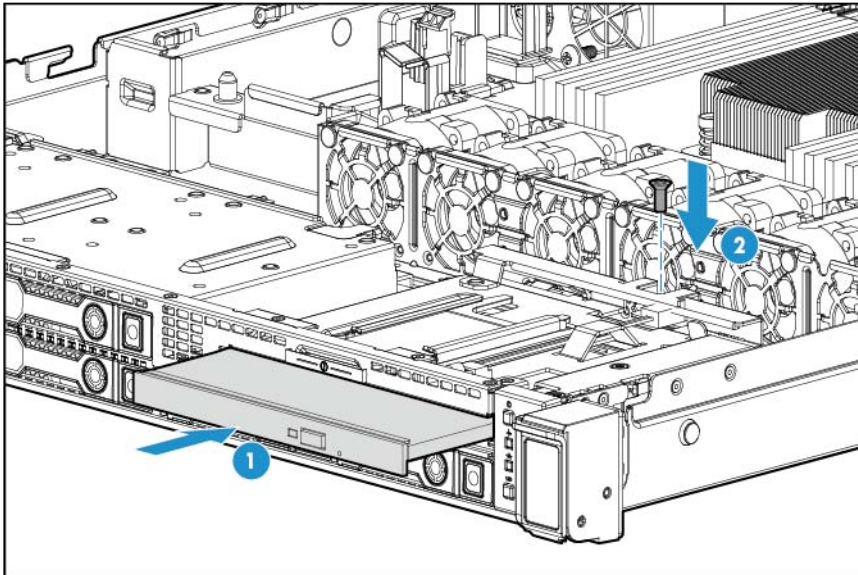

After sliding in the optical drive, be sure to secure the drive with the screw.

7. Connect the optical drive cable to the optical drive.
8. Route the optical drive cable through the cable clip and connect the cable to the system board SATA connector, and then connect the power cable to the system board power cable connector.

- Four-bay LFF configuration

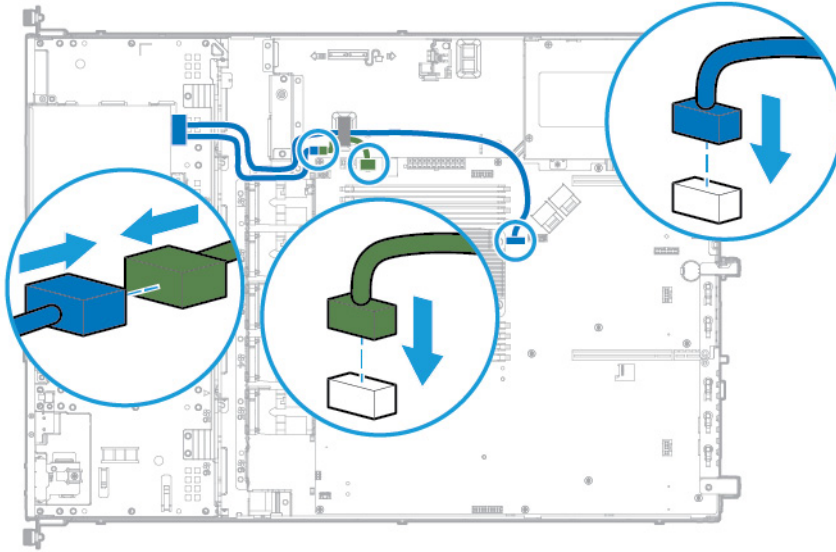

- Eight-bay SFF configuration

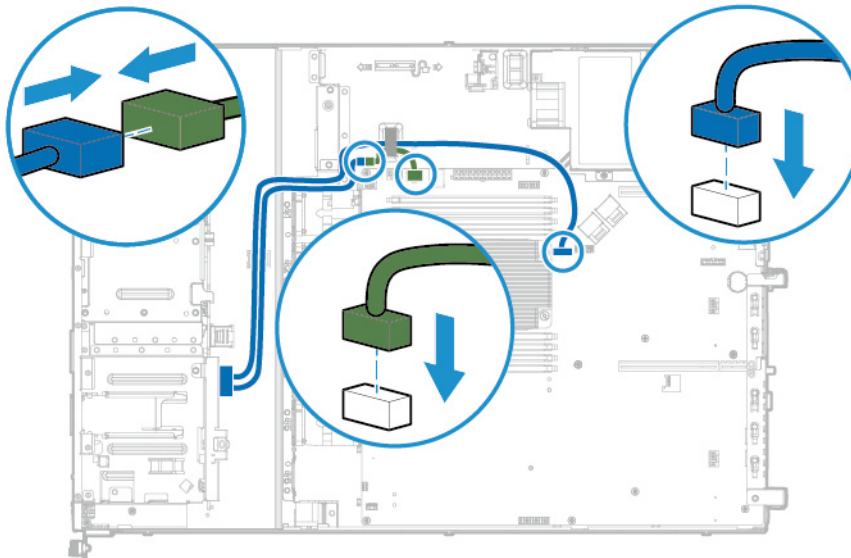

9. Install the access panel (on page 20).
10. Install the server into the rack ("[Installing the server into the rack](#)" on page 30).
11. Power up the server (on page 17).

## Redundant fan option

To provide sufficient airflow to the system if a fan rotor fails, the server supports redundant fans.

# Fan population guidelines

To provide sufficient airflow to the system if a fan fails, the server supports redundant fans.

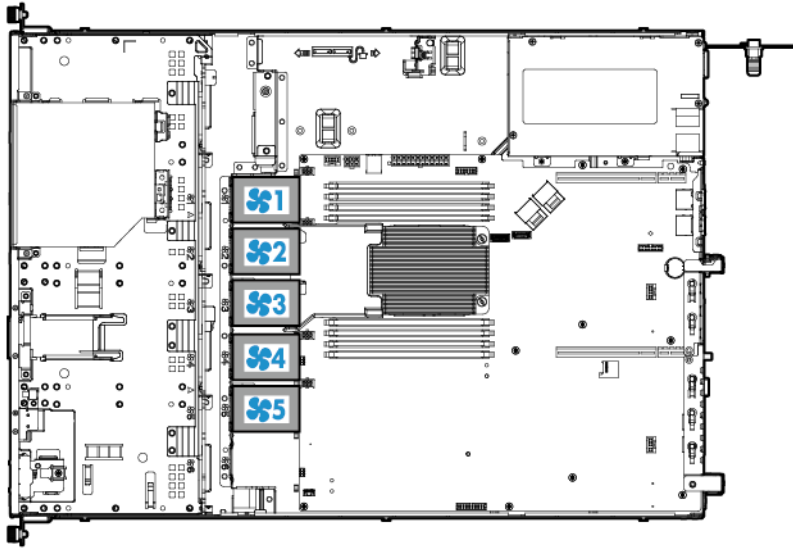

Configuration	Fan bay 1	Fan bay 2	Fan bay 3	Fan bay 4	Fan bay 5
Non-redundant	Fan	Fan	Blank	Fan	Blank
Redundant	Fan	Fan	Fan	Fan	Fan

- In the redundant fan mode:
  - If one fan rotor fails, the system continues to operate without redundancy. This condition is indicated by a flashing amber Health LED.
  - If two fan rotors fail, the system shuts down.
  - The minimum fan requirement to make this server bootable is three fans.

## Installing a hot-swap fan module

**⚠ WARNING:** To reduce the risk of personal injury from hot surfaces, allow the drives and the internal system components to cool before touching them.

To install the component:

1. Power down the server (on page 17).
2. Remove all power:
  - a. Disconnect each power cord from the power source.
  - b. Disconnect each power cord from the server.
3. Do one of the following:
  - Extend the server from the rack (on page 17).
  - Remove the server from the rack (on page 18).
4. Remove the access panel (on page 19).
5. Remove the air baffle (on page 20).

6. To determine which fan blanks need to be removed to install the additional fans, see "Fan population guidelines."
7. Remove the fan blank.

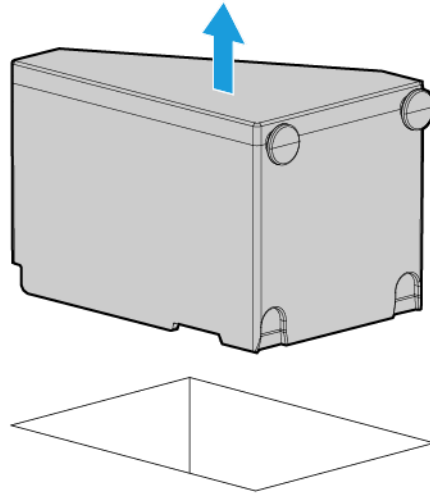

8. Install the fan.

**CAUTION:** The fan does not have a fan guard. Special attention is needed when removing or installing the fan to prevent finger injury.

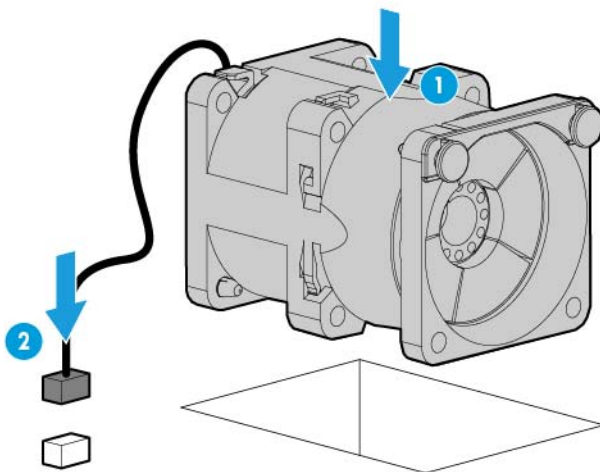

9. Connect the fan cable to the system board.

**CAUTION:** To prevent improper cooling and thermal damage, do not operate the server unless all bays are populated with either a component or a blank.

10. Install the air baffle (on page 21).
11. Install the access panel (on page 20).
12. Do one of the following:

- Slide the server into the rack.
  - Install the server into the rack ("[Installing the server into the rack](#)" on page 30).
13. Power up the server (on page 17).

## Memory options



**IMPORTANT:** This server does not support mixing LRDIMMs and RDIMMs. Attempting to mix any combination of these DIMMs can cause the server to halt during BIOS initialization.

The memory subsystem in this server can support LRDIMMs or RDIMMs:

- RDIMMs offer address parity protection.
- LRDIMMs support higher densities than single-rank and dual-rank RDIMMs. This support enables you to install more high capacity DIMMs, resulting in higher system capacities and higher bandwidth.

All types are referred to as DIMMs when the information applies to all types. When specified as LRDIMM or RDIMM, the information applies to that type only. All memory installed in the server must be of the same type.

The server supports the following DIMM speeds:

- Single-rank and dual-rank PC4-2133 (DDR4-2133) RDIMMs operating at up to 2133 MT/s
- Dual-rank and quad-rank PC4-2133 (DDR4-2133) LRDIMMs operating at up to 2133 MT/s

Depending on the processor model, the number of DIMMs installed, and whether LRDIMMs or RDIMMs are installed, the memory clock speed might be reduced to 1600 MT/s.

### Supported DIMM specifications

Type	Rank	Capacity	Native speed	Voltage
RDIMM	Single	4 GB	2133 MT/s	STD
RDIMM	Single	8 GB	2133 MT/s	STD
RDIMM	Dual	8 GB	2133 MT/s	STD
RDIMM	Dual	16 GB	2133 MT/s	STD
LRDIMM	Dual	16 GB	2133 MT/s	STD
LRDIMM	Quad	32 GB	2133 MT/s	STD

### Populated DIMM speed (MT/s)

Type	Rank	1 DIMM per channel
RDIMM	Single	2133 MT/s
RDIMM	Dual	2133 MT/s
LRDIMM	Dual	2133 MT/s
LRDIMM	Quad	2133 MT/s

## HP SmartMemory

HP SmartMemory authenticates and unlocks certain features available only on HP Qualified memory and verifies whether installed memory has passed HP qualification and test processes. Qualified memory is performance-tuned for HP ProLiant and BladeSystem servers and provides future enhanced support through HP Active Health and manageability software.

The memory subsystem in this server is divided into channels. The processor supports four channels, and each channel supports two DIMM slots.

Channel	Population order	Slot number
1	A	1
	E	2
2	B	3
	F	4
3	C	8
	G	7
4	D	6
	H	5

For the location of the slot numbers, see "DIMM slot locations (on page 13)."

DIMM slots in this server are identified by number and by letter. Letters identify the population order. Slot numbers indicate the DIMM slot ID for spare replacement.

## Single-, dual-, and quad-rank DIMMs

To understand and configure memory protection modes properly, an understanding of single-, dual-, and quad-rank DIMMs is helpful. Some DIMM configuration requirements are based on these classifications.

A single-rank DIMM has one set of memory chips that is accessed while writing to or reading from the memory. A dual-rank DIMM is similar to having two single-rank DIMMs on the same module, with only one rank accessible at a time. A quad-rank DIMM is, effectively, two dual-rank DIMMs on the same module. Only one rank is accessible at a time. The server memory control subsystem selects the proper rank within the DIMM when writing to or reading from the DIMM.

Dual- and quad-rank DIMMs provide the greatest capacity with the existing memory technology. For example, if current DRAM technology supports 8-GB single-rank DIMMs, a dual-rank DIMM would be 16 GB, and a quad-rank DIMM would be 32 GB.

LRDIMMs are labeled as quad-rank DIMMs. There are four ranks of DRAM on the DIMM, but the LRDIMM buffer creates an abstraction that allows the DIMM to appear as a dual-rank DIMM to the system. The LRDIMM buffer isolates the electrical loading of the DRAM from the system to allow for faster operation. This allows higher memory operating speed compared to quad-rank RDIMMs.

## DIMM identification

To determine DIMM characteristics, use the label attached to the DIMM and the following illustration and table.

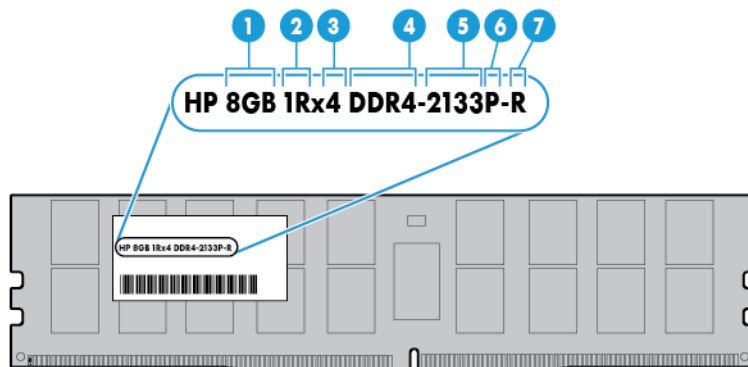

Item	Description	Definition
1	Capacity	8 GB 16 GB 32 GB
2	Rank	1R = Single-rank 2R = Dual-rank 4R = Quad-rank
3	Data width	x4 = 4-bit x8 = 8-bit
4	Memory generation	DDR4
5	Maximum memory speed	2133 MT/s
6	CAS latency	P=15
7	DIMM type	R = RDIMM (registered) L = LRDIMM (load reduced)

For more information about product features, specifications, options, configurations, and compatibility, see the product QuickSpecs on the HP website (<http://www.hp.com/go/qs>).

## Memory configurations

To optimize server availability, the server supports the following AMP modes:

- Advanced ECC—Provides up to 4-bit error correction and enhanced performance over Lockstep mode. This mode is the default option for this server.
- Online spare memory—Provides protection against failing or degraded DIMMs. Certain memory is reserved as spare, and automatic failover to spare memory occurs when the system detects a DIMM that is degrading. This allows DIMMs that have a higher probability of receiving an uncorrectable memory error (which would result in system downtime) to be removed from operation.

Advanced Memory Protection options are configured in the BIOS/Platform Configuration (RBSU). If the requested AMP mode is not supported by the installed DIMM configuration, the server boots in Advanced ECC mode. For more information, see the *HP UEFI System Utilities User Guide for HP ProLiant Gen9 Servers* on the HP website (<http://www.hp.com/go/ProLiantUEFI/docs>).

### Maximum capacity

DIMM type	DIMM rank	Total capacity
RDIMM	Single-rank (4 GB)	32 GB
RDIMM	Single-rank (8 GB)	64 GB
RDIMM	Dual-rank (16 GB)	128 GB
LRDIMM	Quad-rank (32 GB)	256 GB

For the latest memory configuration information, see the product QuickSpecs on the HP website (<http://www.hp.com/go/qs>).

## Advanced ECC memory configuration

Advanced ECC memory is the default memory protection mode for this server. Standard ECC can correct single-bit memory errors and detect multi-bit memory errors. When multi-bit errors are detected using Standard ECC, the error is signaled to the server and causes the server to halt.

Advanced ECC protects the server against some multi-bit memory errors. Advanced ECC can correct both single-bit memory errors and 4-bit memory errors if all failed bits are on the same DRAM device on the DIMM.

Advanced ECC provides additional protection over Standard ECC because it is possible to correct certain memory errors that would otherwise be uncorrected and result in a server failure. Using HP Advanced Memory Error Detection technology, the server provides notification when a DIMM is degrading and has a higher probability of uncorrectable memory error.

## Online Spare memory configuration

Online spare memory provides protection against degraded DIMMs by reducing the likelihood of uncorrected memory errors. This protection is available without any operating system support.

Online spare memory protection dedicates one rank of each memory channel for use as spare memory. The remaining ranks are available for OS and application use. If correctable memory errors occur at a rate higher than a specific threshold on any of the non-spare ranks, the server automatically copies the memory contents of the degraded rank to the online spare rank. The server then deactivates the failing rank and automatically switches over to the online spare rank.

## General DIMM slot population guidelines

Observe the following guidelines for all AMP modes:

- Do not mix LRDIMMs and RDIMMs.
- White DIMM slots denote the first slot of a channel (Ch 1-A, Ch 2-B, Ch 3-C, Ch 4-D).
- Install DIMMs in sequential alphabetic order: A, B, C, D, E, and so forth.
- When single-rank, dual-rank, and quad-rank DIMMs are populated for two DIMMs per channel, always populate the higher number rank DIMM first (starting from the farthest slot). For example, first quad-rank DIMM, then dual-rank DIMM, and then lastly single-rank DIMM.
- DIMMs should be populated starting farthest from the processor on each channel.



For more information about server memory, see the HP website (<http://www.hp.com/go/memory>).

The DIMM speeds supported in this server are listed in the following table:

Populated slots (per channel)	Rank	Speeds supported (MT/s)
1	Single, dual, or quad-rank	2133
2	Single, dual, or quad-rank	2133

## Advanced ECC population guidelines

For Advanced ECC mode configurations, observe the following guidelines:

- Observe the general DIMM slot population guidelines.
- DIMMs may be installed individually.

## Online spare population guidelines

For Online Spare memory mode configurations, observe the following guidelines:

- Observe the general DIMM slot population guidelines.
- Each channel must have a valid online spare configuration.
- Each channel can have a different valid online spare configuration.
- Each populated channel must have a spare rank. A single dual-rank DIMM is not a valid configuration.

## Installing a DIMM

1. Power down the server (on page 17).
2. Remove all power:
  - a. Disconnect each power cord from the power source.
  - b. Disconnect each power cord from the server.
3. Do one of the following:
  - o Extend the server from the rack (on page 17).
  - o Remove the server from the rack (on page 18).
4. Remove the access panel (on page 19).
5. Open the DIMM slot latches.

6. Install the DIMM.

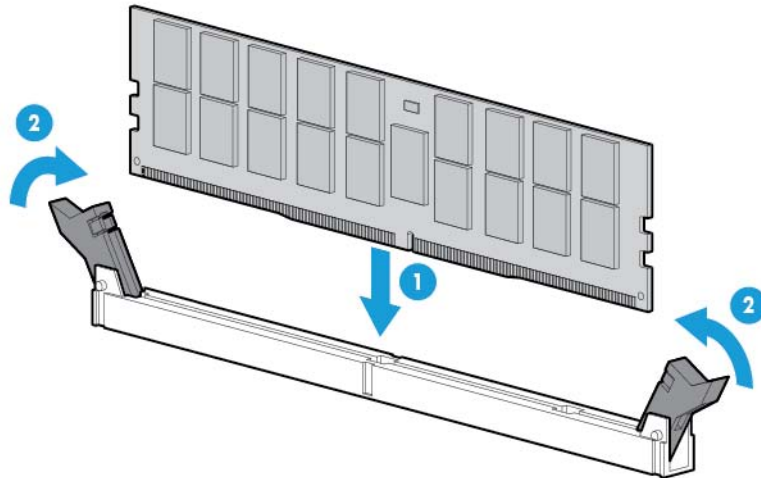

7. Install the access panel (on page 20).
8. Do one of the following:
  - o Slide the server into the rack.
  - o Install the server into the rack ("Installing the server into the rack" on page 30).
9. Power up the server (on page 17).

After installing the DIMMs, to configure memory protection mode, use RBSU.

## FlexibleLOM option

For more information about product features, specifications, options, configurations, and compatibility, see the product QuickSpecs on the HP website (<http://www.hp.com/go/qs>).

To install the component:

1. Power down the server (on page 17).
2. Remove all power:
  - a. Disconnect each power cord from the power source.
  - b. Disconnect each power cord from the server.
3. Do one of the following:
  - o Extend the server from the rack (on page 17).
  - o Remove the server from the rack (on page 18).
4. Remove the access panel (on page 19).
5. If necessary, disconnect any internal cables connected to the system board.

6. Remove the PCI riser cage.

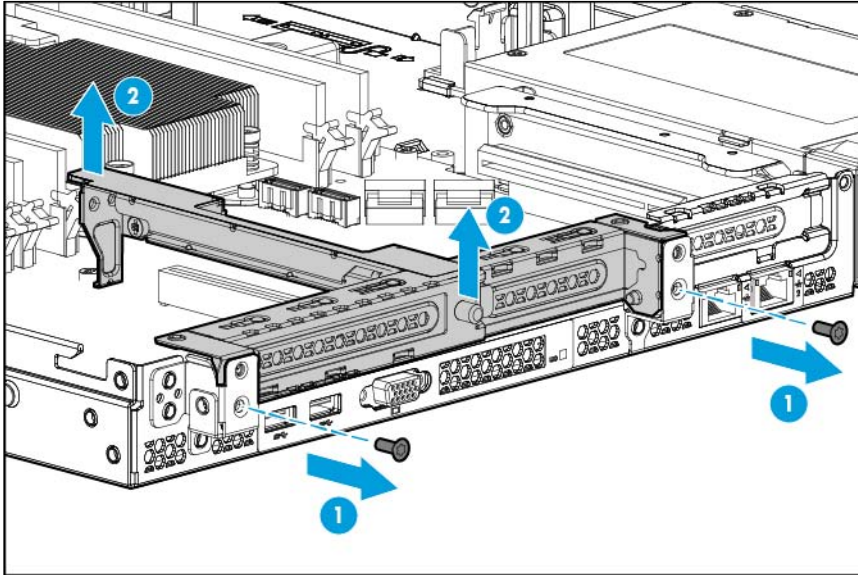

Retain the cage and screws for future use.

7. Remove the blank from the FlexibleLOM slot of the riser cage.

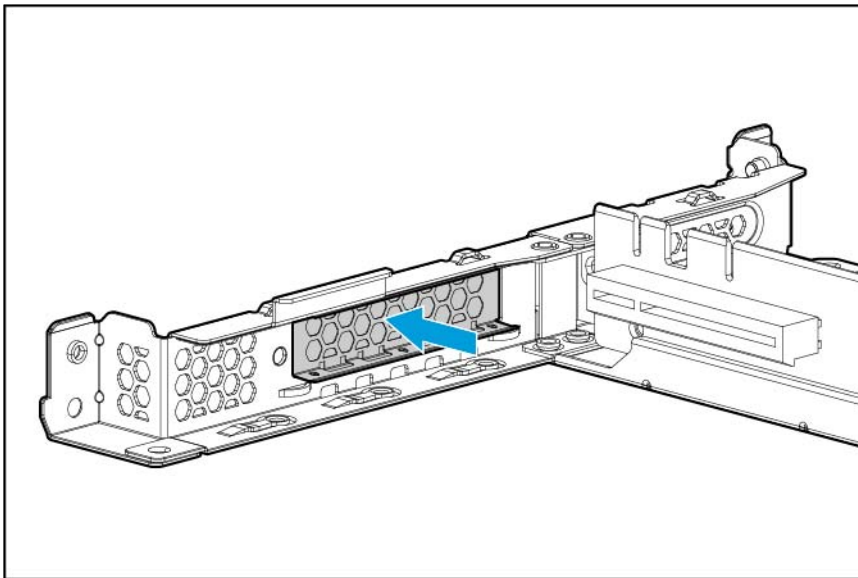

8. Install the component:
  - a. Firmly seat the FlexibleLOM into the slot.

- b. Tighten the T-15 screw to secure the component.

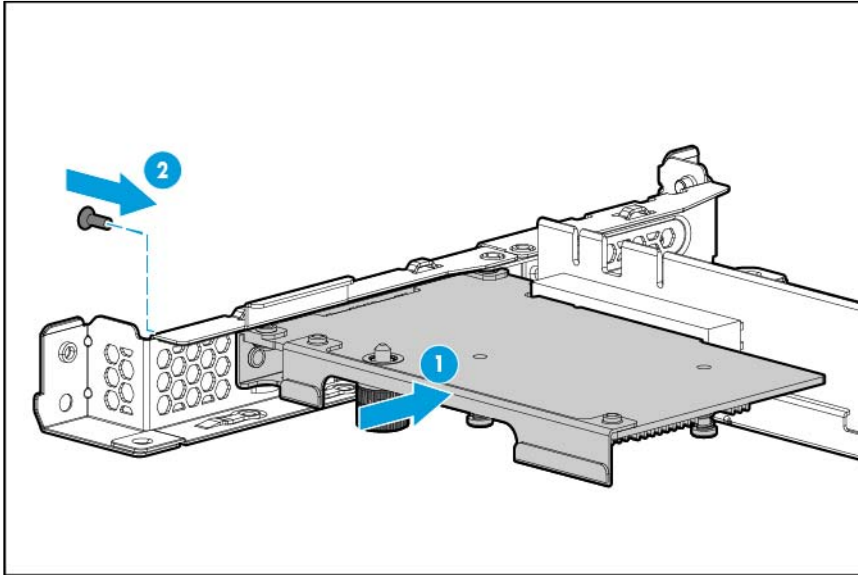

9. Align the PCI riser board with the corresponding connector on the system board, and then press down the riser cage.
10. Tighten the two screws to secure the assembly.

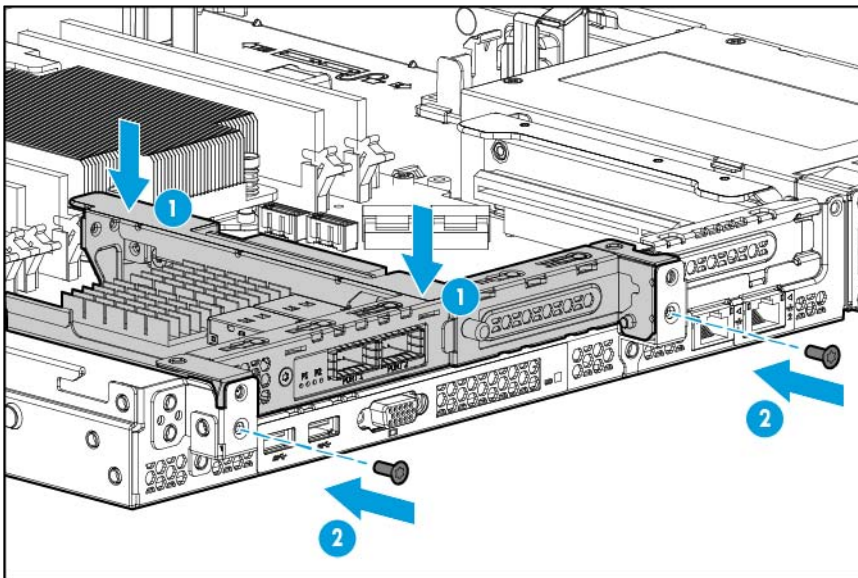

**CAUTION:** To prevent improper cooling and thermal damage, do not operate the server unless all PCI slots have either an expansion slot cover or an expansion board installed.

11. Install the access panel (on page 20).
12. Do one of the following:
- Slide the server into the rack.
  - Install the server into the rack ("Installing the server into the rack" on page 30).
13. Power up the server (on page 17).

# PCIe x8 Full-height riser option

**CAUTION:** To prevent improper cooling and thermal damage, do not operate the server unless all PCI slots have either an expansion slot cover or an expansion board installed.

For more information about product features, specifications, options, configurations, and compatibility, see the product QuickSpecs on the HP website (<http://www.hp.com/go/qs>).

To install the component:

1. Power down the server (on page 17).
2. Remove all power:
  - a. Disconnect each power cord from the power source.
  - b. Disconnect each power cord from the server.
3. Do one of the following:
  - o Extend the server from the rack (on page 17).
  - o Remove the server from the rack (on page 18).
4. Remove the access panel (on page 19).
5. Remove the PCI blank.

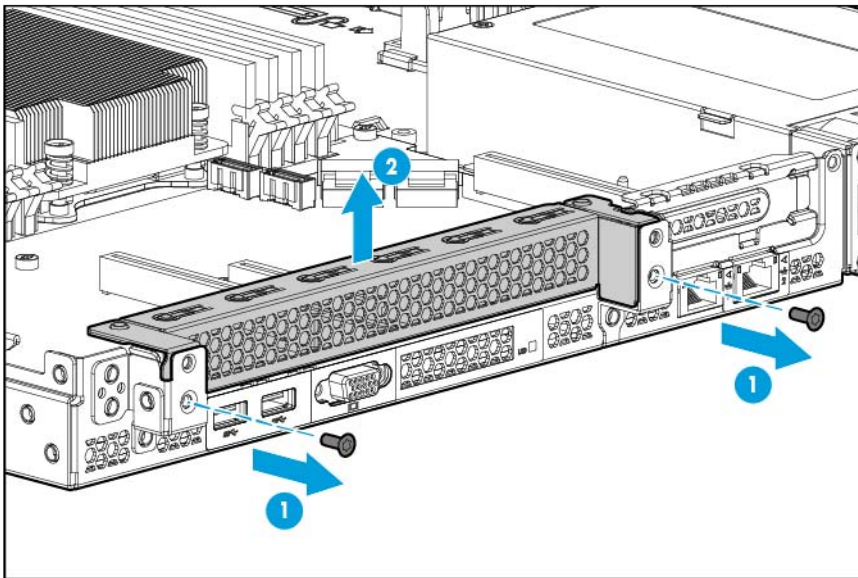

Retain the blank and screws for future use.

6. Remove the slot cover from the riser cage.

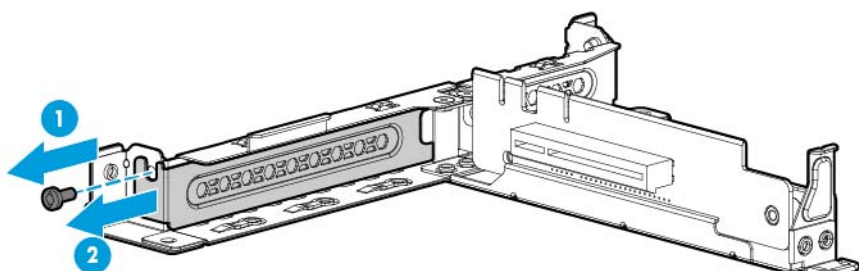

7. Install the expansion board.

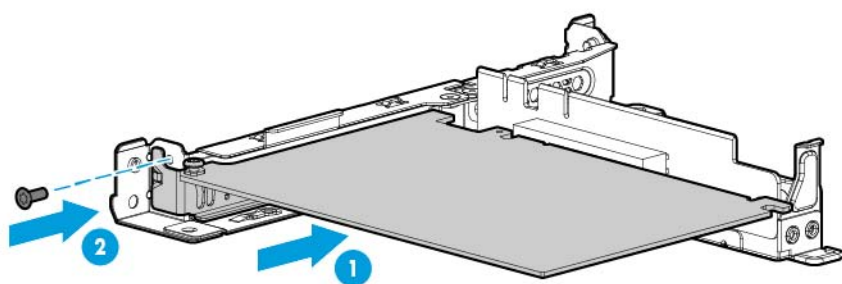

8. Align the PCI riser board with the corresponding connector on the system board, and then press down the riser cage.

9. Tighten the two screws to secure the cage.

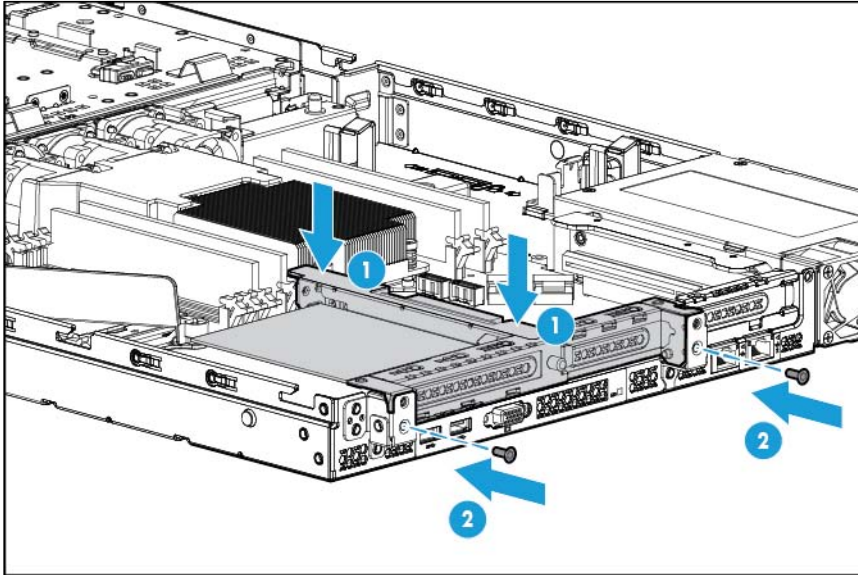

10. Install the access panel (on page 20).
11. Install the server into the rack ("Installing the server into the rack" on page 30).
12. Power up the server (on page 17).

## Expansion board options

The server has both full-height/half-length and low-profile expansion slots for controller option installation.

For more information about product features, specifications, options, configurations, and compatibility, see the product QuickSpecs on the HP website (<http://www.hp.com/go/qs>).

- 
- CAUTION:** To prevent damage to the server or expansion boards, power down the server, and disconnect all power cords before removing or installing the PCI riser cage.
- 
- CAUTION:** To prevent improper cooling and thermal damage, do not operate the server unless all expansion slots have either an expansion slot cover or an expansion board installed.
- 

To install the component:

1. Power down the server (on page 17).
2. Remove all power:
  - a. Disconnect each power cord from the power source.
  - b. Disconnect each power cord from the server.
3. Do one of the following:
  - o Extend the server from the rack (on page 17).
  - o Remove the server from the rack (on page 18).
4. Remove the access panel (on page 19).
5. Remove the secondary PCI riser cage. ("Remove the PCI riser cage" on page 22)
6. Identify the expansion slot compatible with the new option, and then remove the cover opposite that slot.

- Slot 1 (If a secondary PCI riser cage is installed, remove the secondary cage before removing the primary riser blank.)

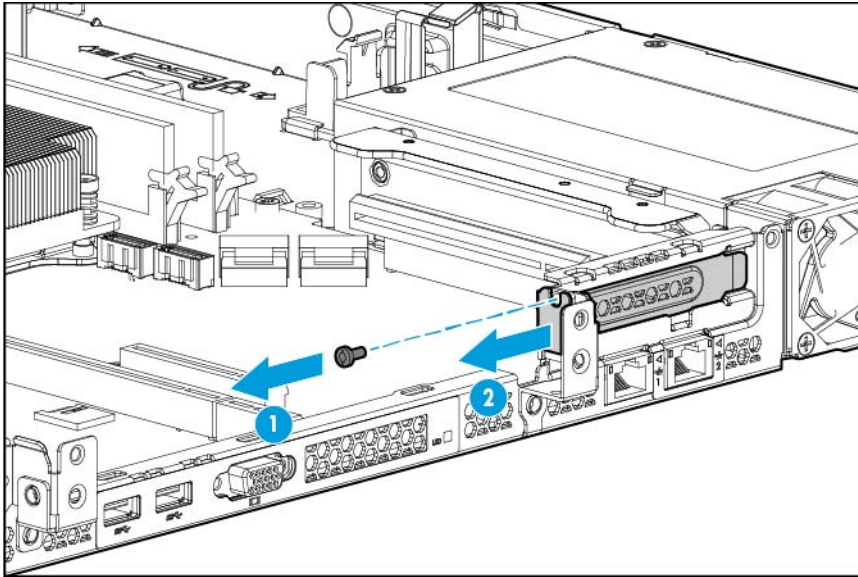

- Slot 2

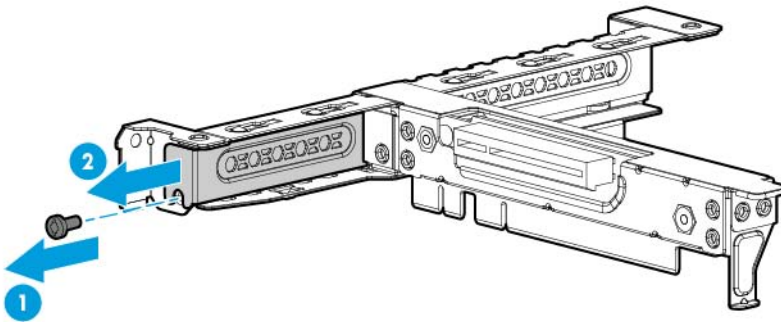

- Slot 3

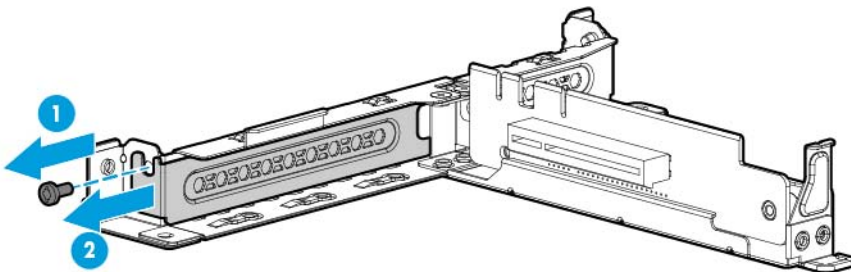

7. Install the expansion board.



- Slot 1 (If a secondary PCI riser cage is installed, remove the secondary cage before installing the expansion board into slot 1.)

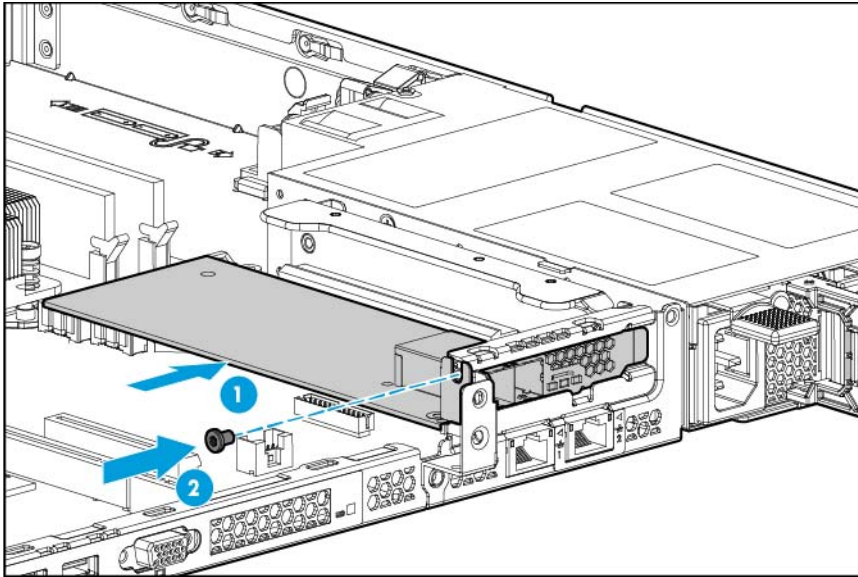

- Slot 2

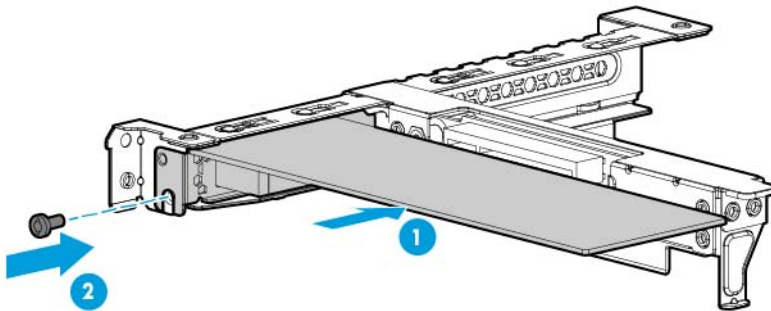

- Slot 3

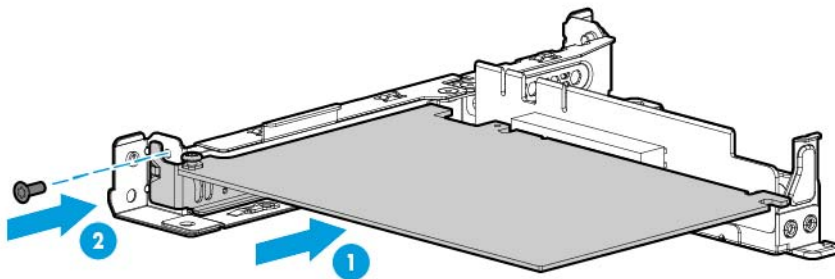

- Align the PCI riser board with the corresponding connector on the system board, and then press down the riser cage.
- Tighten the two screws to secure the cage.

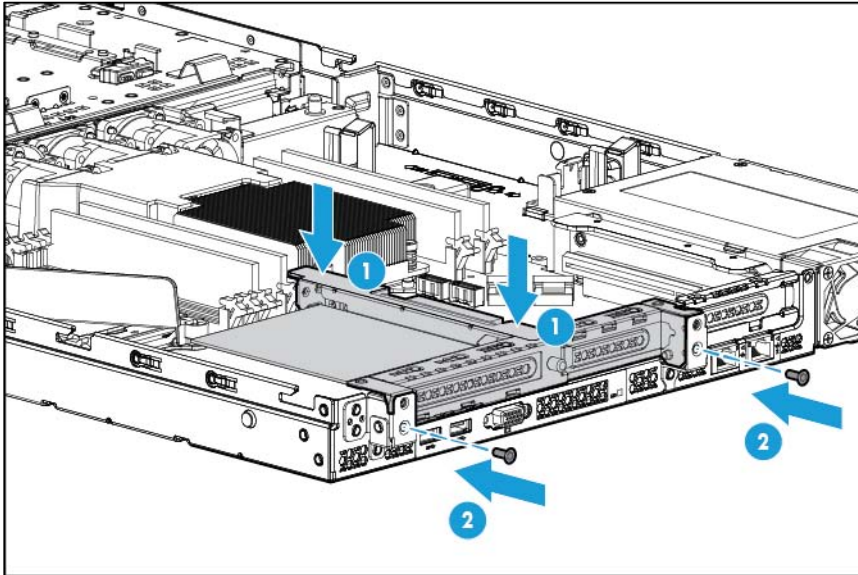

**IMPORTANT:** The server does not power up if the PCI riser cage is not seated properly.

- Install the access panel (on page 20).
- Install the server into the rack ("[Installing the server into the rack](#)" on page 30).
- Power up the server (on page 17).

## Redundant power supply option

Install the RPS backplane option to improve power efficiency and enable power redundancy. Power redundancy requires the installation of two power input modules. This module is not part of the RPS backplane option kit.

When this RPS backplane and a single power input module are installed in the server, you can install or remove a second power input module without powering down the server.

To install the component:

- Power down the server (on page 17).
- Remove all power:
  - Disconnect each power cord from the power source.
  - Disconnect each power cord from the server.
- Do one of the following:
  - Extend the server from the rack (on page 17).
  - Remove the server from the rack (on page 18).
- Remove the access panel (on page 19).
- Prepare the server for removal of the existing power supply:
  - Remove all server components that block access to the power supply cables and screws.

- b. Disconnect all server cables that block access to the power supply cables and screws.
  - c. Disconnect all power supply cables from the system board and drive cage.
6. Remove the existing power supply.

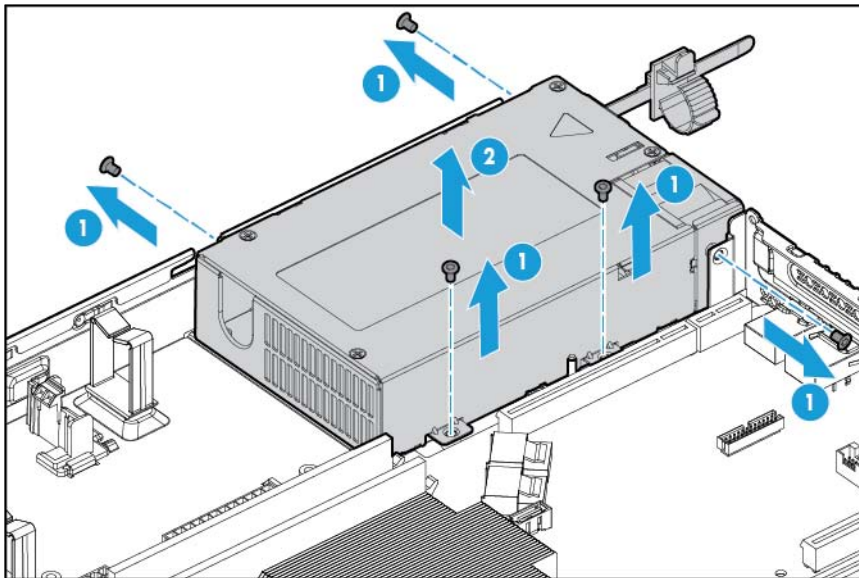

7. Remove all other components specifically associated with the removed power supply.
8. Install the RPS backplane:
- a. Install the RPS backplane into the server.

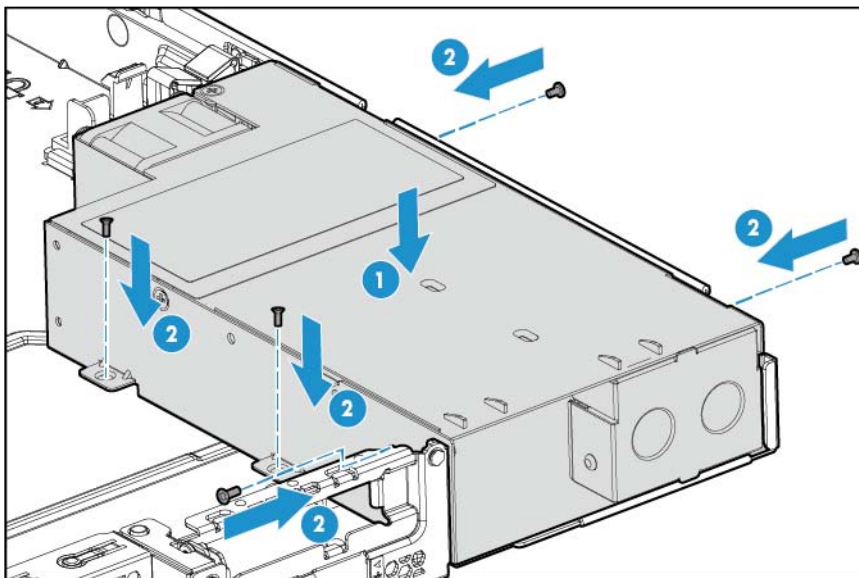

- b. Connect the RPS backplane cables to the system board. For information on cable routing, see "HP Power supply cabling (on page 81)".
9. Install a hot-plug power input module into the power supply bay 1.  
For more information on power supply bay locations, see "Rear panel components (on page 10)".
10. If you intend to enable power redundancy in the server, install a second power input module into power supply bay 2:

- a. Remove the power supply blank.

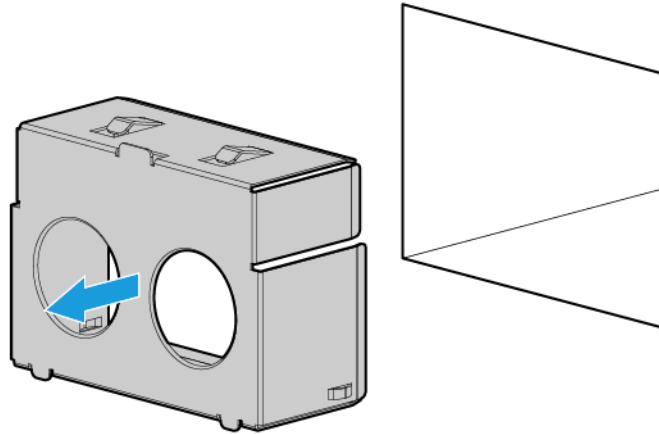

- b. Install a hot-plug power input module into power supply bay 2.

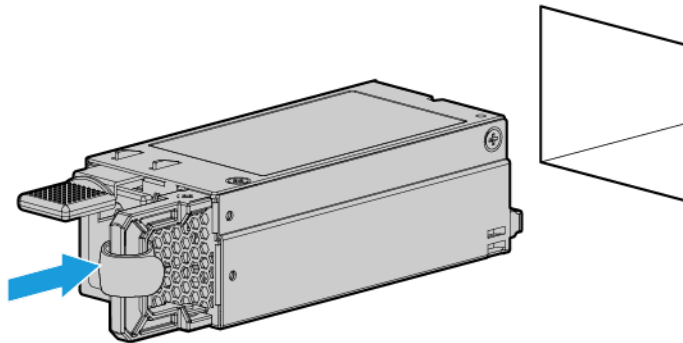

11. Reconnect all server cables that were disconnected to access the removed power supply.
12. Reinstall all server components that were removed to access the removed power supply.

**⚠ CAUTION:** To prevent improper cooling and thermal damage, do not operate the server unless all bays are populated with either a component or a blank.

13. Install the access panel (on page 20).
14. Do one of the following:
  - Slide the server into the rack.
  - Install the server into the rack ("Installing the server into the rack" on page 30).
15. Power up the server (on page 17).

## GPU enablement option

**⚠ CAUTION:** To prevent improper cooling and thermal damage, do not operate the server unless all PCI slots have either an expansion slot cover or an expansion board installed.

For more information about product features, specifications, options, configurations, and compatibility, see the product QuickSpecs on the HP website (<http://www.hp.com/go/qs>).

To install the component:

1. Power down the server (on page 17).
2. Remove all power:
  - a. Disconnect each power cord from the power source.
  - b. Disconnect each power cord from the server.
3. Do one of the following:
  - o Extend the server from the rack (on page 17).
  - o Remove the server from the rack (on page 18).
4. Remove the access panel (on page 19).
5. Remove the air baffle.

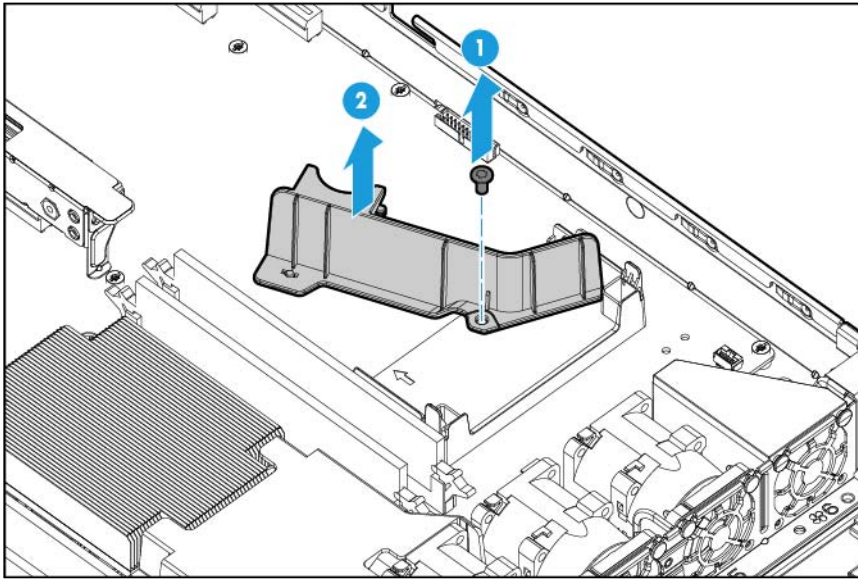

6. Remove the PCI blank or PCI cage, if installed.

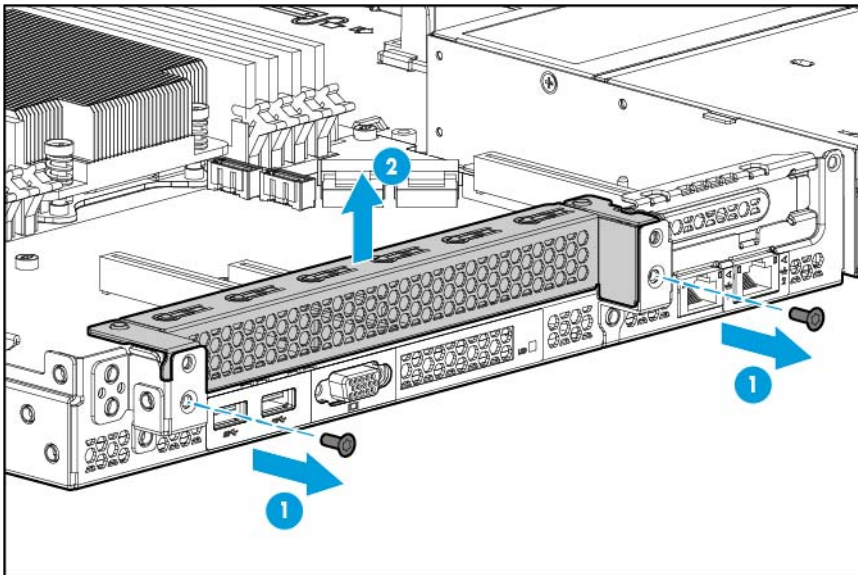

Retain the blank and screws for future use.

7. Remove the slot cover from the riser cage.

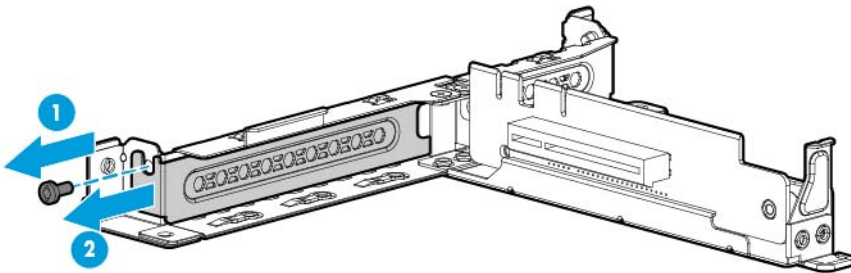

8. Install the GPU into the GPU riser slot.

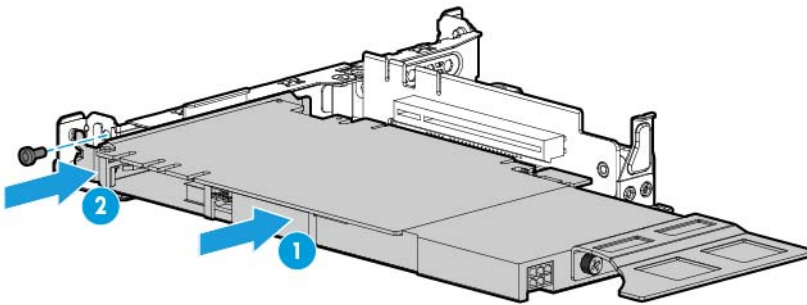

9. Align the PCI riser board with the corresponding connector on the system board, and then press down the riser cage.
10. Tighten the two screws to secure the cage.

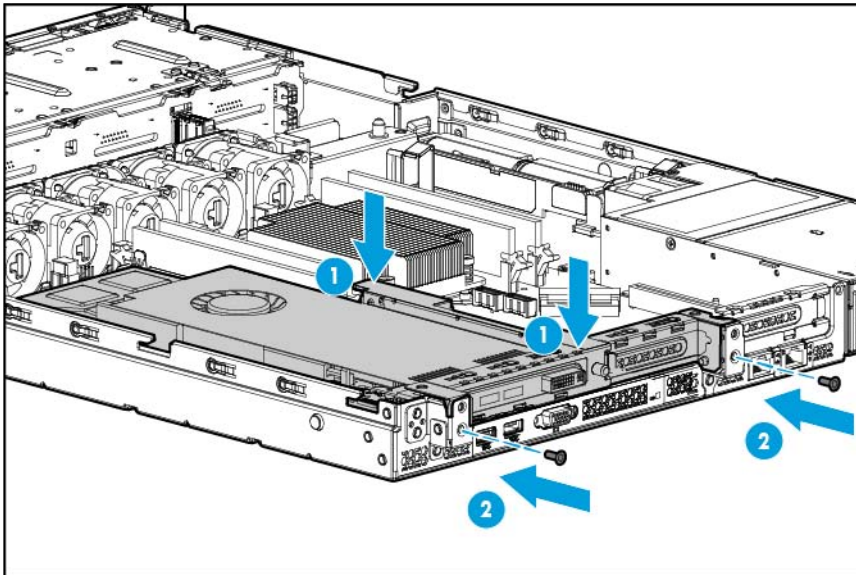

11. Route the power cable through the cable clips, and then connect the power cable to the GPU. For GPU cabling information, see "GPU cabling (on page 84)".  
The GPU can only be supported by the 900 W power supply.

12. Install the access panel (on page 20).
13. Do one of the following:
  - Slide the server into the rack.
  - Install the server into the rack ("Installing the server into the rack" on page 30).
14. Power up the server (on page 17).

## HP Trusted Platform Module option

For more information about product features, specifications, options, configurations, and compatibility, see the product QuickSpecs on the HP website (<http://www.hp.com/go/qs>).

Use these instructions to install and enable a TPM on a supported server. This procedure includes three sections:

1. Installing the Trusted Platform Module board.
2. Retaining the recovery key/password (on page 73).
3. Enabling the Trusted Platform Module (on page 73).

Enabling the TPM requires accessing BIOS/Platform Configuration (RBSU) in HP UEFI System Utilities (on page 91).

TPM installation requires the use of drive encryption technology, such as the Microsoft Windows BitLocker Drive Encryption feature. For more information on BitLocker, see the Microsoft website (<http://www.microsoft.com>).



**CAUTION:** Always observe the guidelines in this document. Failure to follow these guidelines can cause hardware damage or halt data access.

---

When installing or replacing a TPM, observe the following guidelines:

- Do not remove an installed TPM. Once installed, the TPM becomes a permanent part of the system board.
- When installing or replacing hardware, HP service providers cannot enable the TPM or the encryption technology. For security reasons, only the customer can enable these features.
- When returning a system board for service replacement, do not remove the TPM from the system board. When requested, HP Service provides a TPM with the spare system board.
- Any attempt to remove an installed TPM from the system board breaks or disfigures the TPM security rivet. Upon locating a broken or disfigured rivet on an installed TPM, administrators should consider the system compromised and take appropriate measures to ensure the integrity of the system data.
- When using BitLocker, always retain the recovery key/password. The recovery key/password is required to enter Recovery Mode after BitLocker detects a possible compromise of system integrity.
- HP is not liable for blocked data access caused by improper TPM use. For operating instructions, see the encryption technology feature documentation provided by the operating system.

## Installing the Trusted Platform Module board

---

**⚠ WARNING:** To reduce the risk of personal injury, electric shock, or damage to the equipment, remove the power cord to remove power from the server. The front panel Power On/Standby button does not completely shut off system power. Portions of the power supply and some internal circuitry remain active until AC power is removed.

---

**⚠ WARNING:** To reduce the risk of personal injury from hot surfaces, allow the drives and the internal system components to cool before touching them.

---

To install the component:

1. Power down the server (on page 17).
2. Remove all power:
  - a. Disconnect each power cord from the power source.
  - b. Disconnect each power cord from the server.
3. Do one of the following:
  - o Extend the server from the rack (on page 17).
  - o Remove the server from the rack (on page 18).
4. Remove the access panel (on page 19).
5. Remove the secondary PCI riser cage. ("[Remove the PCI riser cage](#)" on page 22)
6. If an expansion board is installed in slot 1, remove the board before installing the TPM.

---

**⚠ CAUTION:** Any attempt to remove an installed TPM from the system board breaks or disfigures the TPM security rivet. Upon locating a broken or disfigured rivet on an installed TPM, administrators should consider the system compromised and take appropriate measures to ensure the integrity of the system data.

---

7. Install the TPM board. Press down on the connector to seat the board.

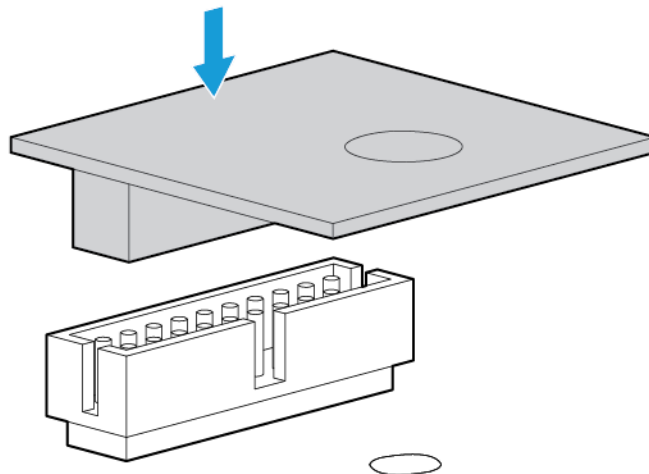



8. Install the TPM security rivet by pressing the rivet firmly into the system board.

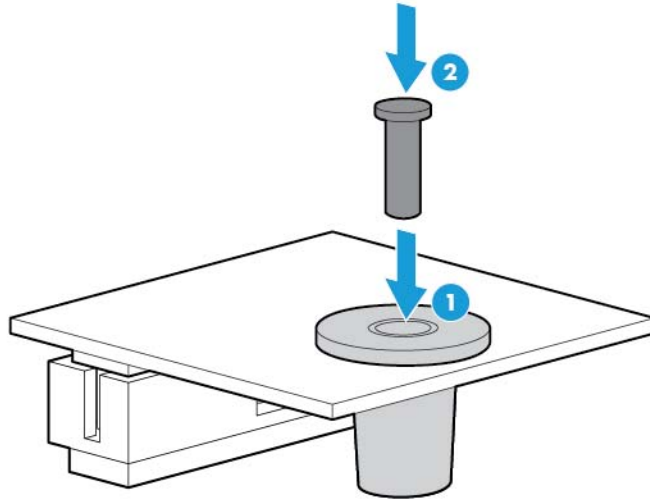

9. Install the secondary PCI riser cage. ("[Install the PCI riser cage](#)" on page 23)
10. Install the access panel (on page 20).
11. Do one of the following:
  - o Slide the server into the rack.
  - o Install the server into the rack ("[Installing the server into the rack](#)" on page 30).
12. Power up the server (on page 17).

## Retaining the recovery key/password

The recovery key/password is generated during BitLocker setup, and can be saved and printed after BitLocker is enabled. When using BitLocker, always retain the recovery key/password. The recovery key/password is required to enter Recovery Mode after BitLocker detects a possible compromise of system integrity.

To help ensure maximum security, observe the following guidelines when retaining the recovery key/password:

- Always store the recovery key/password in multiple locations.
- Always store copies of the recovery key/password away from the server.
- Do not save the recovery key/password on the encrypted hard drive.

## Enabling the Trusted Platform Module

1. During the server startup sequence, press the **F9** key to access System Utilities.
2. From the System Utilities screen, select **System Configuration > BIOS/Platform Configuration (RBSU) > Server Security**.
3. Select **Trusted Platform Module Options** and press the **Enter** key.
4. Select **Enabled** to enable the TPM and BIOS secure startup. The TPM is fully functional in this mode.
5. Press the **F10** key to save your selection.

6. When prompted to save the change in System Utilities, press the **Y** key.
7. Press the **ESC** key to exit System Utilities. Then, press the **Enter** key when prompted to reboot the server.

The server then reboots a second time without user input. During this reboot, the TPM setting becomes effective.

You can now enable TPM functionality in the OS, such as Microsoft Windows BitLocker or measured boot.



**CAUTION:** When a TPM is installed and enabled on the server, data access is locked if you fail to follow the proper procedures for updating the system or option firmware, replacing the system board, replacing a hard drive, or modifying OS application TPM settings.

For more information on firmware updates and hardware procedures, see the *HP Trusted Platform Module Best Practices White Paper* on the HP website (<http://www.hp.com/support>).

For more information on adjusting TPM usage in BitLocker, see the Microsoft website (<http://technet.microsoft.com/en-us/library/cc732774.aspx>).

# Cabling

## Cabling overview

This section provides guidelines that help you make informed decisions about cabling the server and hardware options to optimize performance.

For information on cabling peripheral components, refer to the white paper on high-density deployment at the HP website (<http://www.hp.com/products/servers/platforms>).

**CAUTION:** When routing cables, always be sure that the cables are not in a position where they can be pinched or crimped.

## Storage cabling

Depending on the controller option installed, the actual storage controller connectors might look different from what is shown in this section.

### Four-bay LFF non-hot-plug drive cabling

- Four-bay LFF non-hot-plug drive backplane connected to the system board

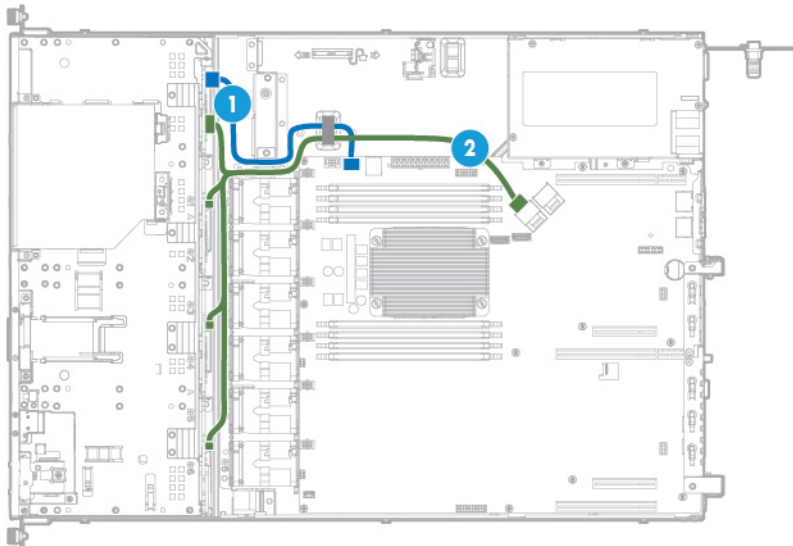

Item	Description
1	Drive power cable
2	Mini-SAS cable

- Four-bay LFF non-hot-plug drive backplane connected to the H240 host-bus adapter

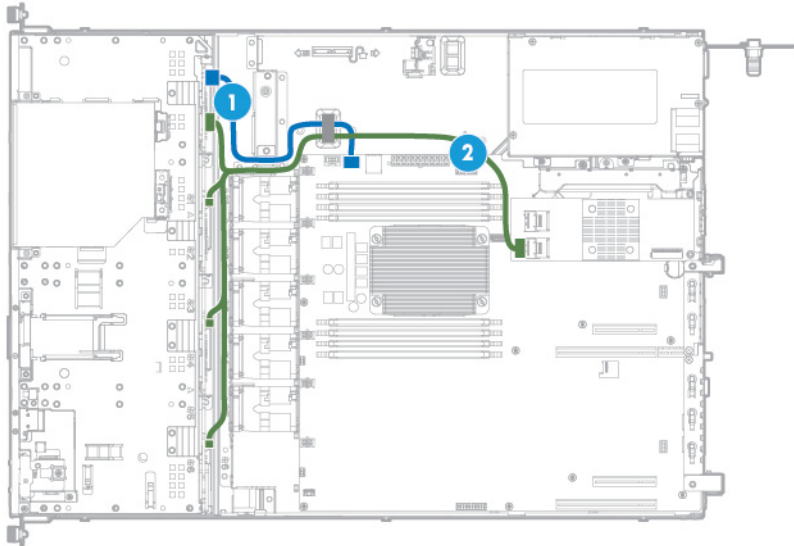

Item	Description
1	Drive power cable
2	Mini-SAS cable

## Four-bay LFF hot-plug drive cabling

- Four-bay LFF drive backplane connected to the system board

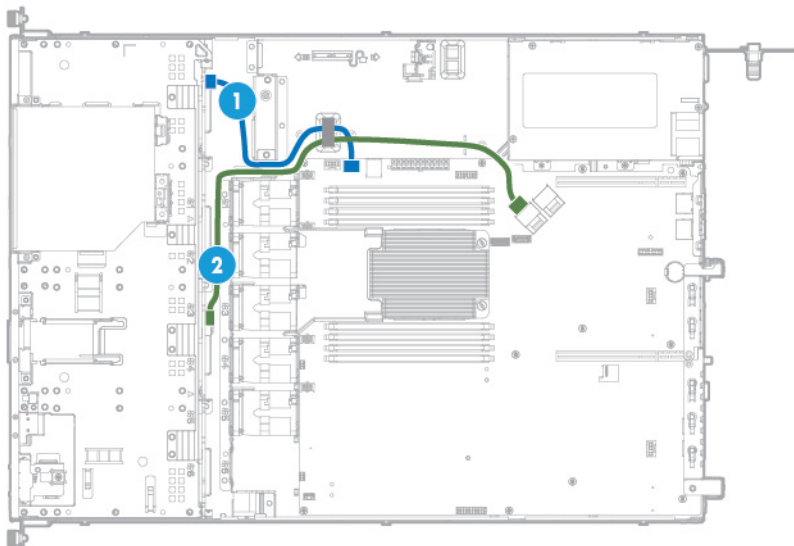

Item	Description
1	Drive power cable
2	Mini-SAS cable

- Four-bay LFF drive backplane connected to a P440 controller in the low-profile expansion slot

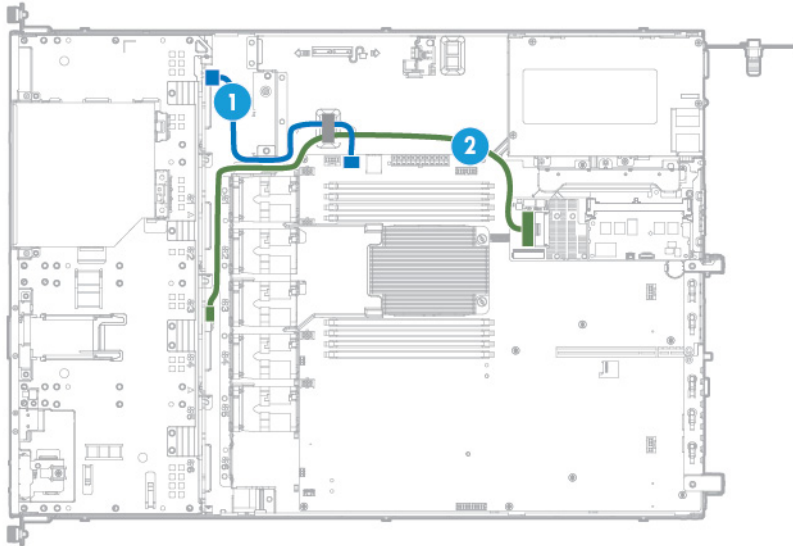

Item	Description
1	Drive power cable
2	Mini-SAS cable

- Four-bay LFF drive backplane connected to an H240 adapter in the low-profile expansion slot

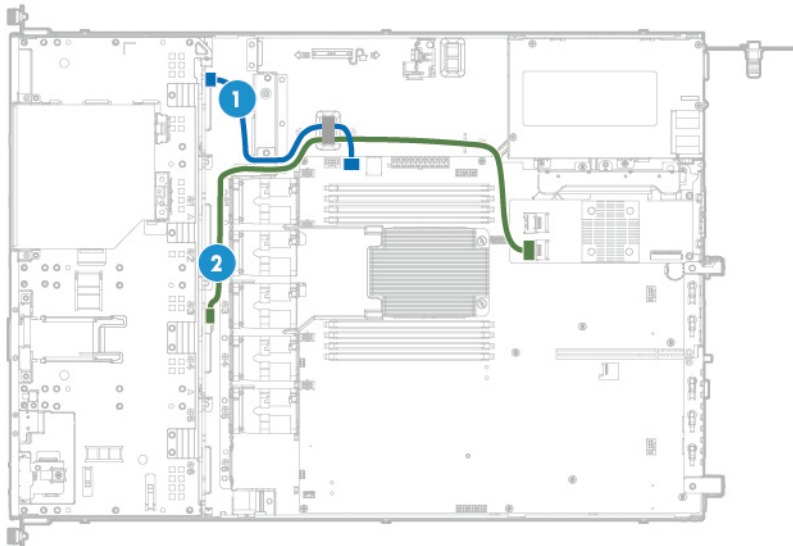

Item	Description
1	Drive power cable
2	Mini-SAS cable

# Eight-bay SFF hot-plug drive cabling

- Eight-bay SFF drive backplane connected to the system board

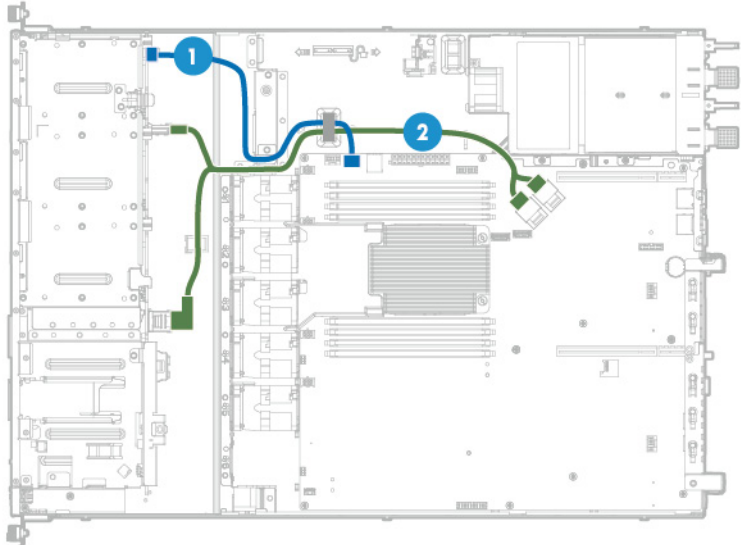

Item	Description
1	Drive power cable
2	Mini-SAS cable

- Eight-bay SFF drive backplane connected to a P440 controller in the low-profile expansion slot

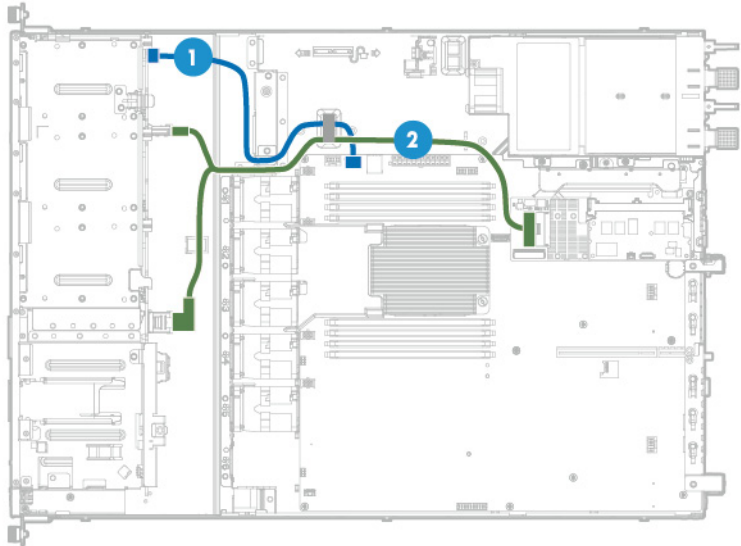

Item	Description
1	Drive power cable
2	Mini-SAS cable

- Eight-bay SFF drive backplane connected to an H240 adapter in the low-profile expansion slot

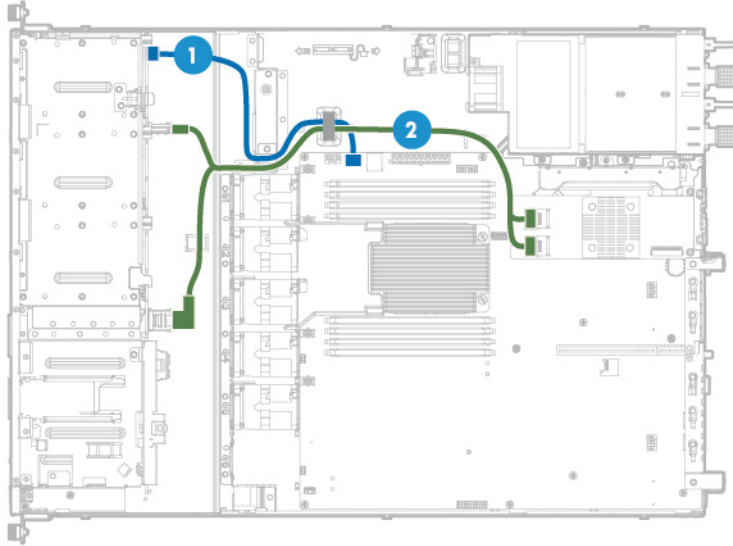

Item	Description
1	Drive power cable
2	Mini-SAS cable

## FBWC cabling

Depending on the controller option installed, the actual storage controller connectors might look different from what is shown in this section.

- FBWC module cabling for storage controller installed in PCIe slot 1

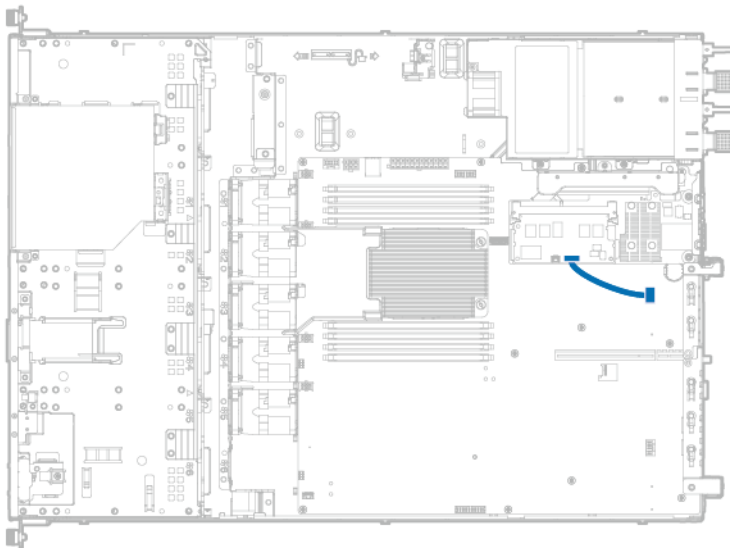

- FBWC module cabling for storage controller installed in PCIe slot 2

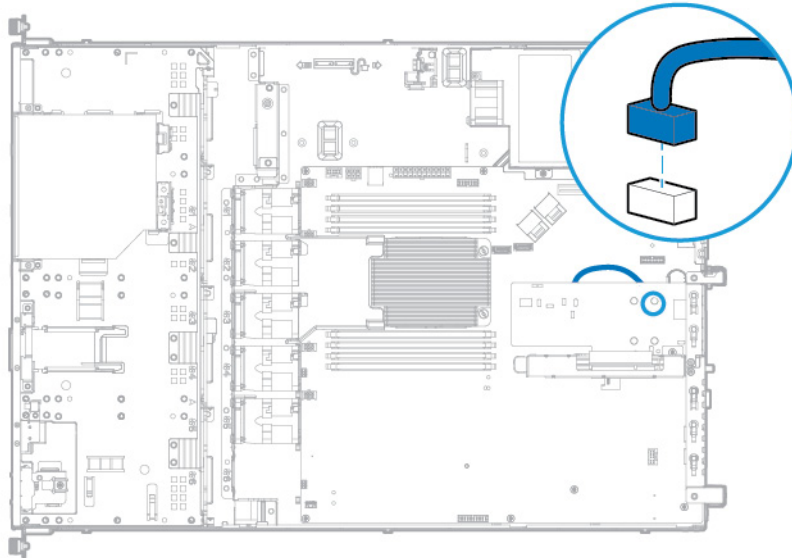

- FBWC module cabling for storage controller installed in PCIe slot 3

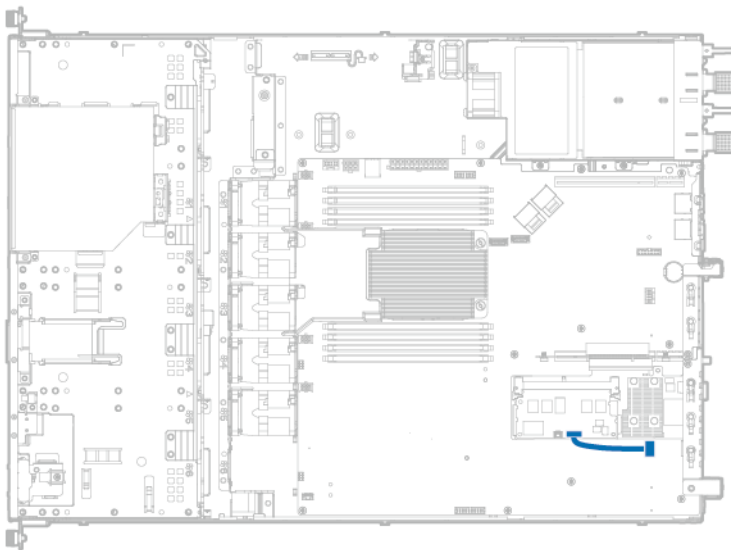



# HP Smart Storage battery cabling

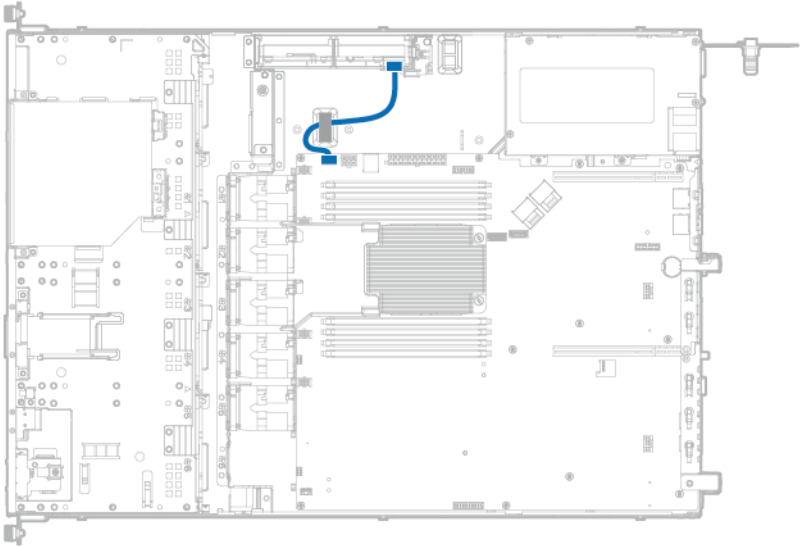

# HP Power supply cabling

- HP 550 W Power Supply cabling

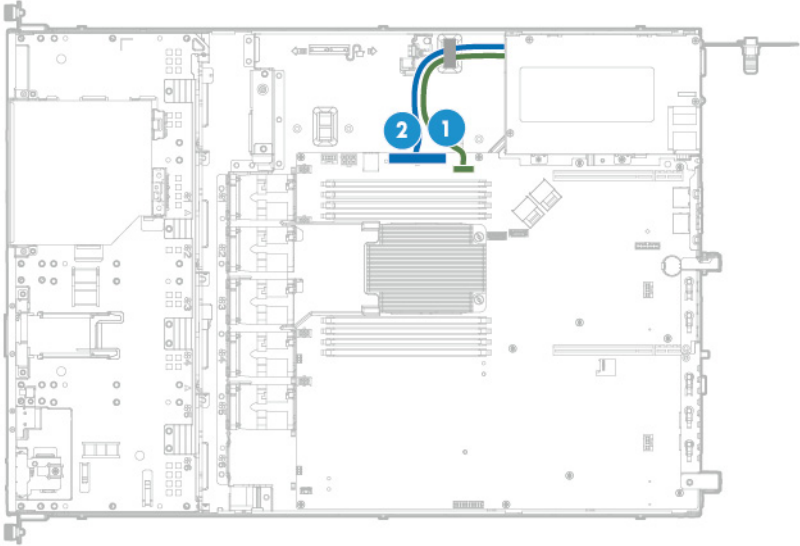

Item	Description
1	16-pin power supply sideband signal cable
2	24-pin power supply cable

- HP RPS backplane cabling

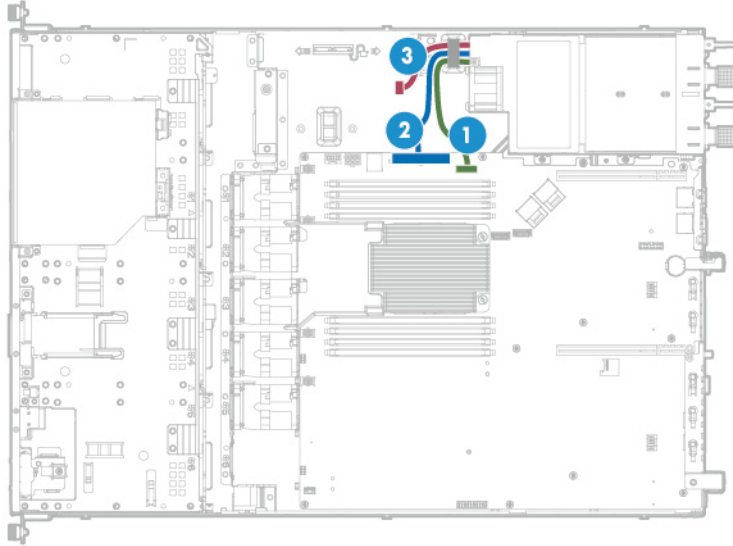

Item	Description
1	16-pin power supply sideband signal cable
2	24-pin power supply cable
3	10-pin RPS cable for GPU

## Optical drive cabling

- Four-bay LFF configuration

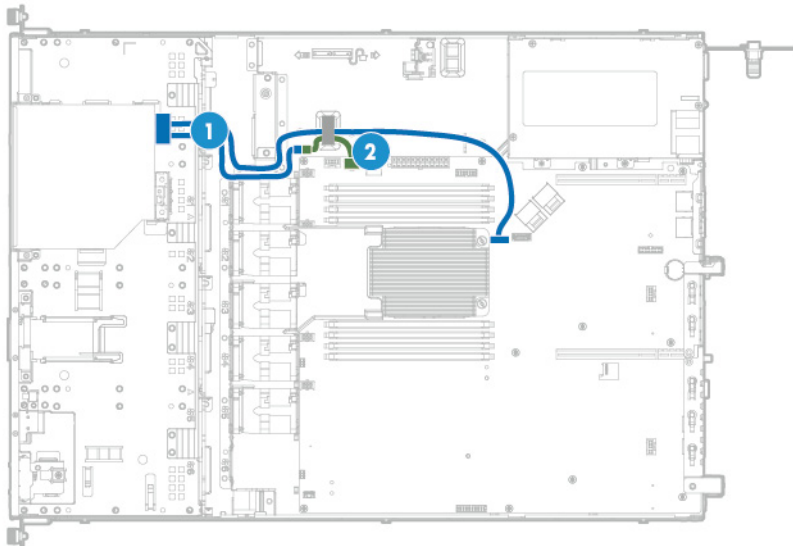

Item	Description
1	Drive power cable
2	Optical drive cable

- Eight-bay SFF configuration

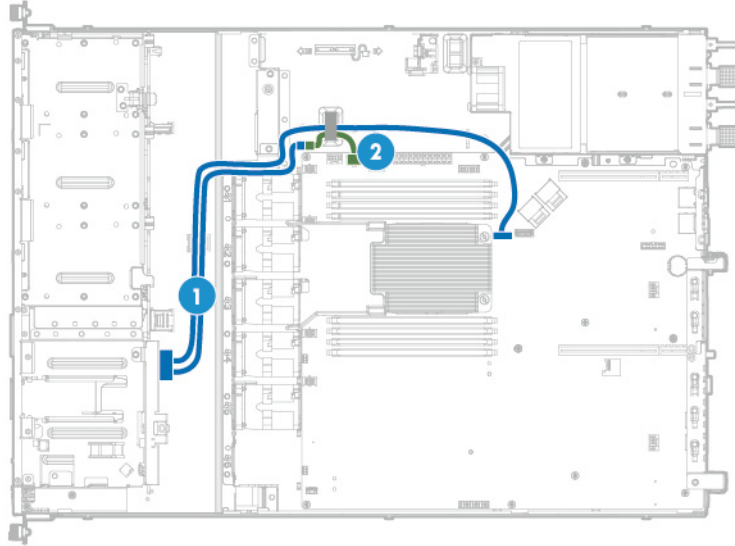

Item	Description
1	Drive power cable
2	Optical drive cable

## Front I/O cabling

- Four-bay LFF configuration

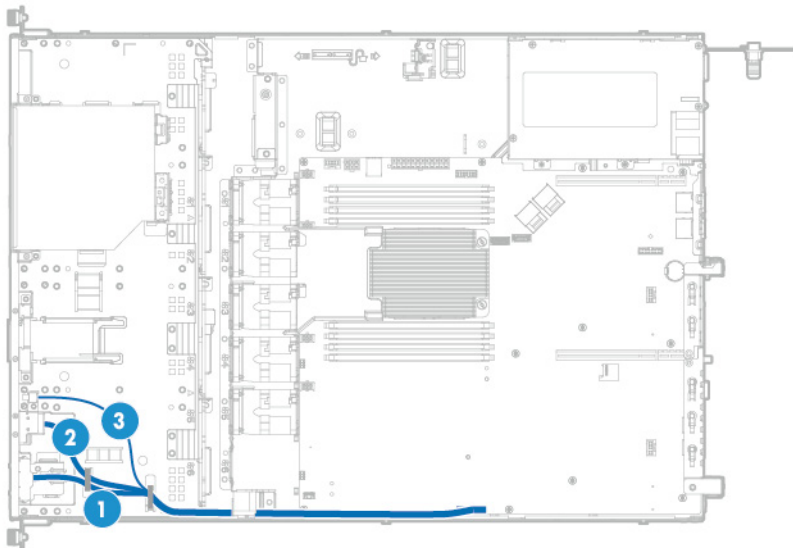

Item	Description
1	Front I/O cable
2	USB 2.0 connector cable
3	Ambient temperature sensor cable

- Eight-bay SFF configuration

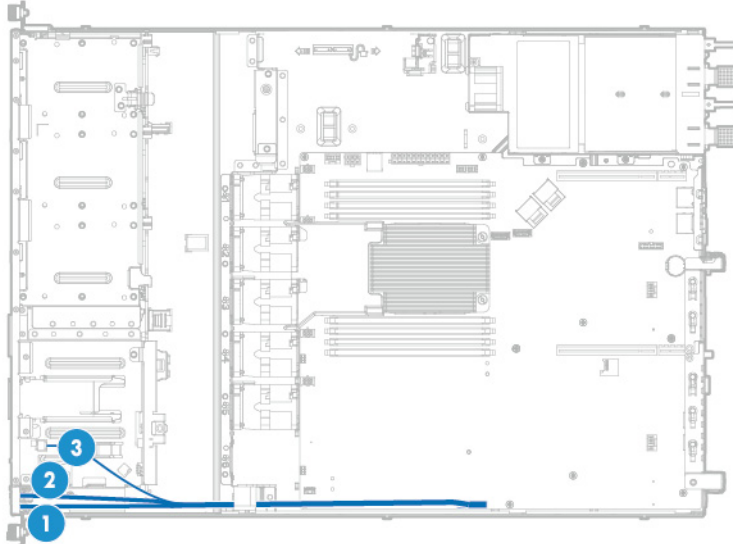

Item	Description
1	Front I/O cable
2	USB 2.0 connector cable
3	Ambient temperature sensor cable

## GPU cabling

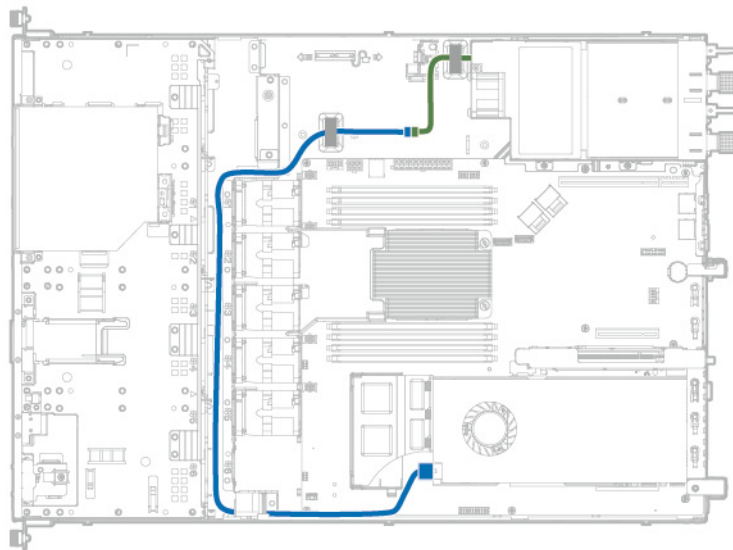

---

# Software and configuration utilities

## Server mode

The software and configuration utilities presented in this section operate in online mode, offline mode, or in both modes.

Software or configuration utility	Server mode
HP iLO (on page 85)	Online and Offline
Active Health System (on page 86)	Online and Offline
HP RESTful API support for HP iLO (on page 87)	Online and Offline
Integrated Management Log (on page 87)	Online and Offline
HP Insight Remote Support (on page 88)	Online
HP Insight Online (on page 88)	Online
Intelligent Provisioning (on page 88)	Offline
HP Insight Diagnostics (on page 89)	Online and Offline
Erase Utility (on page 89)	Offline
Scripting Toolkit for Windows and Linux (on page 90)	Online
HP Service Pack for ProLiant (on page 90)	Online and Offline
HP Smart Update Manager (on page 90)	Online and Offline
HP UEFI System Utilities (on page 91)	Offline
HP Smart Storage Administrator (on page 94)	Online and Offline
FWUPDATE utility (on page 96)	Offline

## Product QuickSpecs

For more information about product features, specifications, options, configurations, and compatibility, see the product QuickSpecs on the HP website (<http://www.hp.com/go/qs>).

## HP iLO

The iLO 4 subsystem is a standard component of HP ProLiant servers that simplifies initial server setup, server health monitoring, power and thermal optimization, and remote server administration. The iLO 4 subsystem includes an intelligent microprocessor, secure memory, and a dedicated network interface. This design makes iLO 4 independent of the host server and its operating system.

iLO 4 enables and manages the Active Health System (on page 86) and also features Agentless Management. All key internal subsystems are monitored by iLO 4. If enabled, SNMP alerts are sent directly by iLO 4 regardless of the host operating system or even if no host operating system is installed.

Embedded remote support software is available on HP ProLiant Gen8 and later servers with iLO 4, regardless of the operating system software and without installing OS agents on the server.

Using iLO 4, you can do the following:

- Access a high-performance and secure Integrated Remote Console to the server from anywhere in the world if you have a network connection to the server.
- Use the shared .NET Integrated Remote Console to collaborate with up to four server administrators.
- Remotely mount high-performance Virtual Media devices to the server.
- Securely and remotely control the power state of the managed server.
- Implement true Agentless Management with SNMP alerts from HP iLO, regardless of the state of the host server.
- Download the Active Health System log.
- Register for HP Insight Remote Support.
- Use iLO Federation to manage multiple servers from one system running the iLO web interface.
- Use Virtual Power and Virtual Media from the GUI, the CLI, or the iLO scripting toolkit for many tasks, including the automation of deployment and provisioning.
- Control iLO by using a remote management tool.

For more information about iLO 4 features, see the iLO 4 documentation on the HP website (<http://www.hp.com/go/ilo/docs>).

The HP iLO 4 hardware and firmware features and functionality, such as NAND size and embedded user partition, vary depending on the server model. For a complete list of supported features and functionality, see the HP iLO 4 QuickSpecs on the HP website ([http://h18000.www1.hp.com/products/quickspecs/14276\\_div/14276\\_div.pdf](http://h18000.www1.hp.com/products/quickspecs/14276_div/14276_div.pdf)).

## Active Health System

HP Active Health System provides the following features:

- Combined diagnostics tools/scanners
- Always on, continuous monitoring for increased stability and shorter downtimes
- Rich configuration history
- Health and service alerts
- Easy export and upload to Service and Support

The HP Active Health System monitors and records changes in the server hardware and system configuration. The Active Health System assists in diagnosing problems and delivering rapid resolution if server failures occur.

The Active Health System collects the following types of data:

- Server model
- Serial number
- Processor model and speed
- Storage capacity and speed
- Memory capacity and speed
- Firmware/BIOS

HP Active Health System does not collect information about Active Health System users' operations, finances, customers, employees, partners, or data center, such as IP addresses, host names, user names, and passwords. HP Active Health System does not parse or change operating system data from third-party error event log activities, such as content created or passed through by the operating system.

The data that is collected is managed according to the HP Data Privacy policy. For more information see the HP website (<http://www.hp.com/go/privacy>).

The Active Health System, in conjunction with the system monitoring provided by Agentless Management or SNMP Pass-thru, provides continuous monitoring of hardware and configuration changes, system status, and service alerts for various server components.

The Agentless Management Service is available in the SPP, which can be downloaded from the HP website (<http://www.hp.com/go/spp/download>). The Active Health System log can be downloaded manually from iLO 4 or HP Intelligent Provisioning and sent to HP.

For more information, see the following documents:

- *HP iLO User Guide* on the HP website (<http://www.hp.com/go/ilo/docs>)
- *HP Intelligent Provisioning User Guide* on the HP website (<http://www.hp.com/go/intelligentprovisioning/docs>)

## HP RESTful API support for HP iLO

HP iLO 4 firmware version 2.00 and later includes the HP RESTful API. The HP RESTful API is a management interface that server management tools can use to perform configuration, inventory, and monitoring of an HP ProLiant server via iLO. A REST client sends HTTPS operations to the iLO web server to GET and PATCH JSON-formatted data, and to configure supported iLO and server settings, such as the UEFI BIOS settings.

HP iLO 4 supports the HP RESTful API with HP ProLiant Gen8 and later servers. For more information about the HP RESTful API, see the HP website (<http://www.hp.com/support/restfulinterface/docs>).

## Integrated Management Log

The IML records hundreds of events and stores them in an easy-to-view form. The IML timestamps each event with 1-minute granularity.

You can view recorded events in the IML in several ways, including the following:

- From within HP SIM
- From within HP UEFI System Utilities (on page 91)
- From within the Embedded UEFI shell (on page 93)
- From within operating system-specific IML viewers:
  - For Windows: IML Viewer
  - For Linux: IML Viewer Application
- From within the iLO 4 web interface
- From within HP Insight Diagnostics (on page 89)

## HP Insight Remote Support

HP strongly recommends that you register your device for remote support to enable enhanced delivery of your HP Warranty, HP Care Pack Service, or HP contractual support agreement. HP Insight Remote Support supplements your monitoring continuously to ensure maximum system availability by providing intelligent event diagnosis, and automatic, secure submission of hardware event notifications to HP, which will initiate a fast and accurate resolution, based on your product's service level. Notifications can be sent to your authorized HP Channel Partner for onsite service, if configured and available in your country.

For more information, see *HP Insight Remote Support and Insight Online Setup Guide for ProLiant Servers and BladeSystem c-Class Enclosures* on the HP website (<http://www.hp.com/go/insightremotesupport/docs>). HP Insight Remote Support is available as part of HP Warranty, HP Care Pack Service, or HP contractual support agreement.

### HP Insight Remote Support central connect

When you use the embedded Remote Support functionality with HP ProLiant Gen8 and later server models and HP BladeSystem c-Class enclosures, you can register a server or rack to communicate to HP through an HP Insight Remote Support centralized Hosting Device in your local environment. All configuration and service event information is routed through the Hosting Device. This information can be viewed by using the local HP Insight Remote Support user interface or the web-based view in HP Insight Online.

For more information, see *HP Insight Remote Support Release Notes* on the HP website (<http://www.hp.com/go/insightremotesupport/docs>).

### HP Insight Online direct connect

When you use the embedded Remote Support functionality with HP ProLiant Gen8 and later server models and HP BladeSystem c-Class enclosures, you can register a server or rack to communicate directly to HP Insight Online without the need to set up an HP Insight Remote Support centralized Hosting Device in your local environment. HP Insight Online will be your primary interface for remote support information.

For more information, see the product documentation on the HP website (<http://www.hp.com/go/insightremotesupport/docs>).

### HP Insight Online

HP Insight Online is a capability of the HP Support Center portal. Combined with HP Insight Remote Support central connect or HP Insight Online direct connect, it automatically aggregates device health, asset, and support information with contract and warranty information, and then secures it in a single, personalized dashboard that is viewable from anywhere at any time. The dashboard organizes your IT and service data to help you understand and respond to that information more quickly. With specific authorization from you, an authorized HP Channel Partner can also view your IT environment remotely using HP Insight Online.

For more information about using HP Insight Online, see the *HP Insight Online User's Guide* on the HP website (<http://www.hp.com/go/insightremotesupport/docs>).

## Intelligent Provisioning

Intelligent Provisioning is a single-server deployment tool embedded in HP ProLiant Gen8 and later servers that simplifies HP ProLiant server setup, providing a reliable and consistent way to deploy HP ProLiant server configurations:



- Intelligent Provisioning assists with the OS installation process by preparing the system for installing "off-the-shelf" and HP branded versions of operating system software and integrating optimized HP ProLiant server support software.
- Intelligent Provisioning provides maintenance-related tasks using the Perform Maintenance window.
- Intelligent Provisioning provides installation help for Microsoft Windows, Red Hat and SUSE Linux, and VMware operating systems. For specific OS support, see the *HP Intelligent Provisioning Release Notes* on the HP website (<http://www.hp.com/go/intelligentprovisioning/docs>).

For more information about Intelligent Provisioning software, see the HP website (<http://www.hp.com/go/intelligentprovisioning>). For Intelligent Provisioning recovery media downloads, see the Resources tab on the HP website (<http://www.hp.com/go/ilo>). For consolidated drive and firmware update packages, see the HP Smart Update: Server Firmware and Driver Updates page on the HP website (<http://www.hp.com/go/SmartUpdate>).

## HP Insight Diagnostics

HP Insight Diagnostics is a proactive server management tool, available in both offline and online versions, that provides diagnostics and troubleshooting capabilities to assist IT administrators who verify server installations, troubleshoot problems, and perform repair validation.

HP Insight Diagnostics Offline Edition performs various in-depth system and component testing while the OS is not running. To run this utility, boot the server using Intelligent Provisioning (on page 88).

HP Insight Diagnostics Online Edition is a web-based application that captures system configuration and other related data needed for effective server management. Available in Microsoft Windows and Linux versions, the utility helps to ensure proper system operation.

For more information or to download the utility, see the HP website (<http://www.hp.com/servers/diags>). HP Insight Diagnostics Online Edition is also available in the SPP ("HP Service Pack for ProLiant" on page 90).

### HP Insight Diagnostics survey functionality

HP Insight Diagnostics (on page 89) provides survey functionality that gathers critical hardware and software information on ProLiant servers.

This functionality supports operating systems that are supported by the server. For operating systems supported by the server, see the HP website (<http://www.hp.com/go/supportos>).

If a significant change occurs between data-gathering intervals, the survey function marks the previous information and overwrites the survey data files to reflect the latest changes in the configuration.

Survey functionality is installed with every Intelligent Provisioning-assisted HP Insight Diagnostics installation, or it can be installed through the SPP ("HP Service Pack for ProLiant" on page 90).

## Erase Utility



**CAUTION:** Perform a backup before running the Erase Utility. The utility sets the system to its original factory state, deletes the current hardware configuration information, including array setup and disk partitioning, and erases all connected hard drives completely. Before using this utility, see the instructions in the *HP Intelligent Provisioning User Guide*.

Use the Erase Utility to erase drives and Active Health System logs, and to reset UEFI System Utilities settings. Run the Erase Utility if you must erase the system for the following reasons:

- You want to install a new operating system on a server with an existing operating system.
- You encounter an error when completing the steps of a factory-installed operating system installation.

To access the Erase Utility, click the Perform Maintenance icon from the Intelligent Provisioning home screen, and then select **Erase**.

For more information about the Erase Utility, see the *HP Intelligent Provisioning User Guide* on the HP website (<http://www.hp.com/go/intelligentprovisioning/docs>).

## Scripting Toolkit for Windows and Linux

The Scripting Toolkit for Windows and Linux is a server deployment product that delivers an unattended automated installation for high-volume server deployments. The Scripting Toolkit is designed to support ProLiant BL, ML, DL, and SL servers. The toolkit includes a modular set of utilities and important documentation that describes how to apply these tools to build an automated server deployment process.

The Scripting Toolkit provides a flexible way to create standard server configuration scripts. These scripts are used to automate many of the manual steps in the server configuration process. This automated server configuration process cuts time from each deployment, making it possible to scale rapid, high-volume server deployments.

For more information, and to download the Scripting Toolkit, see the HP website (<http://www.hp.com/go/ProLiant/STK>).

## HP Service Pack for ProLiant

SPP is a comprehensive systems software (drivers and firmware) solution delivered as a single package with major server releases. This solution uses HP SUM as the deployment tool and is tested on all supported HP ProLiant servers including HP ProLiant Gen8 and later servers.

SPP can be used in an online mode on a Windows or Linux hosted operating system, or in an offline mode where the server is booted to an operating system included on the ISO file so that the server can be updated automatically with no user interaction or updated in interactive mode.

For more information or to download SPP, see one of the following pages on the HP website:

- HP Service Pack for ProLiant download page (<http://www.hp.com/go/spp>)
- HP Smart Update: Server Firmware and Driver Updates page (<http://www.hp.com/go/SmartUpdate>)

## HP Smart Update Manager

HP SUM is a product used to install and update firmware, drivers, and systems software on HP ProLiant servers. HP SUM provides a GUI and a command-line scriptable interface for deployment of systems software for single or one-to-many HP ProLiant servers and network-based targets, such as iLOs, OAs, and VC Ethernet and Fibre Channel modules.

For more information about HP SUM, see the product page on the HP website (<http://www.hp.com/go/hpsum>).

To download HP SUM, see the HP website (<http://www.hp.com/go/hpsum/download>).

To access the *HP Smart Update Manager User Guide*, see the HP SUM Information Library (<http://www.hp.com/go/hpsum/documentation>).

# HP UEFI System Utilities

The HP UEFI System Utilities is embedded in the system ROM. The UEFI System Utilities enable you to perform a wide range of configuration activities, including:

- Configuring system devices and installed options
- Enabling and disabling system features
- Displaying system information
- Selecting the primary boot controller
- Configuring memory options
- Selecting a language
- Launching other pre-boot environments such as the Embedded UEFI Shell and Intelligent Provisioning

For more information on the HP UEFI System Utilities, see the *HP UEFI System Utilities User Guide for HP ProLiant Gen9 Servers* on the HP website (<http://www.hp.com/go/ProLiantUEFI/docs>).

Scan the QR code located at the bottom of the screen to access mobile-ready online help for the UEFI System Utilities and UEFI Shell. For on-screen help, press **F1**.

## Using HP UEFI System Utilities

To use the System Utilities, use the following keys.

Action	Key
Access System Utilities	F9 during server POST
Navigate menus	Up and Down arrows
Select items	Enter
Save selections	F10
Access Help for a highlighted configuration option*	F1

\*Scan the QR code on the screen to access online help for the UEFI System Utilities and UEFI Shell.

Default configuration settings are applied to the server at one of the following times:

- Upon the first system power-up
- After defaults have been restored

Default configuration settings are sufficient for typical server operations; however, you can modify configuration settings as needed. The system prompts you for access to the System Utilities each time the system is powered up.

## Flexible boot control

This feature enables you to do the following:

- Add Boot Options
  - Browse all FAT16 and FAT32 file systems.
  - Select an X64 UEFI application with an .EFI extension to add as a new UEFI boot option, such as an OS boot loader or other UEFI application.

The new boot option is appended to the boot order list. When you select a file, you are prompted to enter the boot option description (which is then displayed in the Boot menu), as well as any optional data to be passed to an .EFI application.

- **Boot to System Utilities**  
After pre-POST, the boot options screen appears. During this time, you can access the System Utilities by pressing the **F9** key.
- **Choose between supported modes: Legacy BIOS Boot Mode or UEFI Boot Mode**



**IMPORTANT:** If the default boot mode settings are different than the user defined settings, the system may not boot the OS installation if the defaults are restored. To avoid this issue, use the User Defined Defaults feature in UEFI System Utilities to override the factory default settings.

For more information, see the *HP UEFI System Utilities User Guide for HP ProLiant Gen9 Servers* on the HP website (<http://www.hp.com/go/ProLiantUEFI/docs>).

## Restoring and customizing configuration settings

You can reset all configuration settings to the factory default settings, or you can restore system default configuration settings, which are used instead of the factory default settings.

You can also configure default settings as necessary, and then save the configuration as the custom default configuration. When the system loads the default settings, it uses the custom default settings instead of the factory defaults.

## Secure Boot configuration

Secure Boot is integrated in the UEFI specification on which the HP implementation of UEFI is based. Secure Boot is completely implemented in the BIOS and does not require special hardware. It ensures that each component launched during the boot process is digitally signed and that the signature is validated against a set of trusted certificates embedded in the UEFI BIOS. Secure Boot validates the software identity of the following components in the boot process:

- UEFI drivers loaded from PCIe cards
- UEFI drivers loaded from mass storage devices
- Pre-boot UEFI shell applications
- OS UEFI boot loaders

Once enabled, only firmware components and operating systems with boot loaders that have an appropriate digital signature can execute during the boot process. Only operating systems that support Secure Boot and have an EFI boot loader signed with one of the authorized keys can boot when Secure Boot is enabled. For more information about supported operating systems, see the *HP UEFI System Utilities and Shell Release Notes* on the HP website (<http://www.hp.com/go/ProLiantUEFI/docs>).

A physically present user can customize the certificates embedded in the UEFI BIOS by adding/removing their own certificates.

## Embedded UEFI shell

The system BIOS in all HP ProLiant Gen9 servers includes an Embedded UEFI Shell in the ROM. The UEFI Shell environment provides an API, a command line prompt, and a set of CLIs that allow scripting, file manipulation, and system information. These features enhance the capabilities of the UEFI System Utilities.

For more information, see the following documents:

- *HP UEFI Shell User Guide for HP ProLiant Gen9 Servers* on the HP website (<http://www.hp.com/go/ProLiantUEFI/docs>)
- *UEFI Shell Specification* on the UEFI website (<http://www.uefi.org/specifications>)

## Embedded Diagnostics option

The system BIOS in all HP ProLiant Gen9 servers includes an Embedded Diagnostics option in the ROM. The Embedded Diagnostics option can run comprehensive diagnostics of the server hardware, including processors, memory, drives, and other server components.

For more information on the Embedded Diagnostics option, see the *HP UEFI System Utilities User Guide for HP ProLiant Gen9 Servers* on the HP website (<http://www.hp.com/go/ProLiantUEFI/docs>).

## HP RESTful API support for UEFI

HP ProLiant Gen9 servers include support for a UEFI compliant System BIOS, along with UEFI System Utilities and Embedded UEFI Shell pre-boot environments. HP ProLiant Gen9 servers also support configuring the UEFI BIOS settings using the HP RESTful API, a management interface that server management tools can use to perform configuration, inventory, and monitoring of an HP ProLiant server. A REST client uses HTTPS operations to configure supported server settings, such as UEFI BIOS settings.

For more information about the HP RESTful API and the HP RESTful Interface Tool, see the HP website (<http://www.hp.com/support/restfulinterface/docs>).

## Re-entering the server serial number and product ID

After you replace the system board, you must re-enter the server serial number and the product ID.

1. During the server startup sequence, press the **F9** key to access UEFI System Utilities.
2. Select the **System Configuration > BIOS/Platform Configuration (RBSU) > Advanced Options > Advanced System ROM Options > Serial Number**, and then press the **Enter** key.
3. Enter the serial number and press the **Enter** key. The following message appears:  
The serial number should only be modified by qualified service personnel. This value should always match the serial number located on the chassis.
4. Press the **Enter** key to clear the warning.
5. Enter the serial number and press the **Enter** key.
6. Select **Product ID**. The following warning appears:  
Warning: The Product ID should ONLY be modified by qualified service personnel. This value should always match the Product ID located on the chassis.
7. Enter the product ID and press the **Enter** key.
8. Press the **F10** key to confirm exiting System Utilities. The server automatically reboots.

# Utilities and features

## HP Smart Storage Administrator

HP SSA is a configuration and management tool for HP Smart Array controllers. Starting with HP ProLiant Gen8 servers, HP SSA replaces ACU with an enhanced GUI and additional configuration features.

HP SSA exists in three interface formats: the HP SSA GUI, the HP SSA CLI, and HP SSA Scripting. Although all formats provide support for configuration tasks, some of the advanced tasks are available in only one format.

Some HP SSA features include the following:

- Supports online array capacity expansion, logical drive extension, assignment of online spares, and RAID or stripe size migration
- Suggests the optimal configuration for an unconfigured system
- Provides diagnostic and SmartSSD Wear Gauge functionality on the Diagnostics tab
- For supported controllers, provides access to additional features.

For more information about HP SSA, see the HP website (<http://www.hp.com/go/hpssa>).

## Automatic Server Recovery

ASR is a feature that causes the system to restart when a catastrophic operating system error occurs, such as a blue screen, ABEND, or panic. A system fail-safe timer, the ASR timer, starts when the System Management driver, also known as the Health Driver, is loaded. When the operating system is functioning properly, the system periodically resets the timer. However, when the operating system fails, the timer expires and restarts the server.

ASR increases server availability by restarting the server within a specified time after a system hang. You can disable ASR from the System Management Homepage or through UEFI System Utilities.

## USB support

HP servers support both USB 2.0 ports and USB 3.0 ports. Both types of ports support installing all types of USB devices (USB 1.0, USB 2.0, and USB 3.0), but may run at lower speeds in specific situations:

- USB 3.0 capable devices operate at USB 2.0 speeds when installed in a USB 2.0 port.
- When the server is configured for UEFI Boot Mode, HP provides legacy USB support in the pre-boot environment prior to the operating system loading for USB 1.0, USB 2.0, and USB 3.0 speeds.
- When the server is configured for Legacy BIOS Boot Mode, HP provides legacy USB support in the pre-boot environment prior to the operating system loading for USB 1.0 and USB 2.0 speeds. While USB 3.0 ports can be used with all devices in Legacy BIOS Boot Mode, they are not available at USB 3.0 speeds in the pre-boot environment. Standard USB support (USB support from within the operating system) is provided by the OS through the appropriate USB device drivers. Support for USB 3.0 varies by operating system.

For maximum compatibility of USB 3.0 devices with all operating systems, HP provides a configuration setting for USB 3.0 Mode. Auto is the default setting. This setting impacts USB 3.0 devices when connected to USB 3.0 ports in the following manner:

- **Auto (default)**—If configured in Auto Mode, USB 3.0 capable devices operate at USB 2.0 speeds in the pre-boot environment and during boot. When a USB 3.0 capable OS USB driver loads, USB 3.0 devices transition to USB 3.0 speeds. This mode provides compatibility with operating systems that do not support USB 3.0 while still allowing USB 3.0 devices to operate at USB 3.0 speeds with state-of-the-art operating systems.
- **Enabled**—If Enabled, USB 3.0 capable devices operate at USB 3.0 speeds at all times (including the pre-boot environment) when in UEFI Boot Mode. This mode should not be used with operating systems that do not support USB 3.0. If operating in Legacy Boot BIOS Mode, the USB 3.0 ports cannot function in the pre-boot environment and are not bootable.
- **Disabled**—If configured for Disabled, USB 3.0 capable devices function at USB 2.0 speeds at all times.

The pre-OS behavior of the USB ports is configurable in System Utilities, so that the user can change the default operation of the USB ports. For more information, see the *HP UEFI System Utilities User Guide for HP ProLiant Gen9 Servers* on the HP website (<http://www.hp.com/go/ProLiantUEFI/docs>).

## External USB functionality

HP provides external USB support to enable local connection of USB devices for server administration, configuration, and diagnostic procedures.

For additional security, external USB functionality can be disabled through USB options in UEFI System Utilities.

## Redundant ROM support

The server enables you to upgrade or configure the ROM safely with redundant ROM support. The server has a single ROM that acts as two separate ROM images. In the standard implementation, one side of the ROM contains the current ROM program version, while the other side of the ROM contains a backup version.

---

**NOTE:** The server ships with the same version programmed on each side of the ROM.

---

## Safety and security benefits

When you flash the system ROM, the flashing mechanism writes over the backup ROM and saves the current ROM as a backup, enabling you to switch easily to the alternate ROM version if the new ROM becomes corrupted for any reason. This feature protects the existing ROM version, even if you experience a power failure while flashing the ROM.

## Keeping the system current

### Access to HP Support Materials

Access to some updates for HP ProLiant Servers may require product entitlement when accessed through the HP Support Center support portal. HP recommends that you have an HP Passport set up with relevant entitlements. For more information, see the HP website (<http://h20564.www2.hp.com/portal/site/hpsc/public/kb/docDisplay/?docId=c03859703>).

# Updating firmware or System ROM

Multiple methods exist to update the firmware or System ROM:

- HP Service Pack for ProLiant (on page 90)
- FWUPDATE utility (on page 96)
- FWUpdate command from within the Embedded UEFI shell (on page 96)
- Firmware Update application in System Utilities (on page 97)
- Online Flash components (on page 97)

Product entitlement is required to perform updates. For more information, see "Access to HP Support Materials (on page 95)."

## FWUPDATE utility

The FWUPDATE utility enables you to upgrade the system firmware (BIOS).

To use the utility to upgrade the firmware:

1. Download the FWUPDATE flash component from the HP website (<http://www.hp.com/go/hpsc>).
2. Save the FWUPDATE flash components to a USB key.
3. Set the boot order so the USB key will boot first using one of the following options:
  - Configure the boot order so the USB key is the first bootable device.
  - Press **F11** (Boot Menu) when prompted during system boot to access the **One-Time Boot Menu**. This menu allows you to select the boot device for a specific boot and does not modify the boot order configuration settings.
4. Insert the USB key into an available USB port.
5. Boot the system.

The FWUPDATE utility checks the system and provides a choice (if more than one exists) of available firmware revisions.

To download the flash components, see the HP website (<http://www.hp.com/go/hpsc>).

For more information about the One-Time Boot Menu, see the *HP UEFI System Utilities User Guide for HP ProLiant Gen9 Servers* on the HP website (<http://www.hp.com/go/ProLiantUEFI/docs>).

## FWUpdate command from within the Embedded UEFI Shell

For systems configured in either boot mode, update the firmware:

1. Access the System ROM Flash Binary component for your server from the HP Support Center (<http://www.hp.com/go/hpsc>). When searching for the component, always select **Cross operating system** to locate the binary file.
2. Copy the binary file to a USB media or iLO virtual media.
3. Attach the media to the server.
4. Boot to Embedded Shell.
5. To obtain the assigned file system volume for the USB key, enter `Map -r`. For more information about accessing a file system from the shell, see the *HP UEFI Shell User Guide for HP ProLiant Gen9 Servers* on the HP website (<http://www.hp.com/go/ProLiantUEFI/docs>).



6. Change to the file system that contains the System ROM Flash Binary component for your server. Enter one of the fsx file systems available, such as fs0 or fs1, and press **Enter**.
7. Use the cd command to change from the current directory to the directory that contains the binary file.
8. Enter `fwupdate -d BIOS -f <filename>` to flash the system ROM.  
For help on the FWUPDATE command, enter the command:  
`help fwupdate -b`
9. Reboot the server. A reboot is required after the firmware update for the updates to take effect and for hardware stability to be maintained.

For more information about the commands used in this procedure, see the *HP UEFI Shell User Guide for HP ProLiant Gen9 Servers* on the HP website (<http://www.hp.com/go/ProLiantUEFI/docs>).

## Firmware Update application in System Utilities

For systems configured in either boot mode, update the firmware:

1. Access the System ROM Flash Binary component for your server from the HP Support Center (<http://www.hp.com/go/hpsc>). When searching for the component, always select **Cross Operating System** to find the component.
2. Copy the binary file to a USB media or iLO virtual media.
3. Attach the media to the server.
4. During POST, press **F9** to enter System Utilities.
5. Select **Embedded Applications** → **Firmware Update** → **System ROM** → **Select Firmware File**.
6. Select the device containing the flash file.
7. Select the flash file. This step may take a few moments to complete.
8. Select **Start firmware update** and allow the process to complete.
9. Reboot the server. A reboot is required after the firmware update for the updates to take effect and for hardware stability to be maintained.

## Online Flash components

This component provides updated system firmware that can be installed directly on supported Operating Systems. Additionally, when used in conjunction with HP SUM ("HP Smart Update Manager" on page 90), this Smart Component allows the user to update firmware on remote servers from a central location. This remote deployment capability eliminates the need for the user to be physically present at the server to perform a firmware update.

## Drivers



---

**IMPORTANT:** Always perform a backup before installing or updating device drivers.

---

The server includes new hardware that may not have driver support on all OS installation media.

If you are installing an Intelligent Provisioning-supported OS, use Intelligent Provisioning (on page 88) and its Configure and Install feature to install the OS and latest supported drivers.

If you do not use Intelligent Provisioning to install an OS, drivers for some of the new hardware are required. These drivers, as well as other option drivers, ROM images, and value-add software can be downloaded as part of an SPP.

If you are installing drivers from SPP, be sure that you are using the latest SPP version that your server supports. To verify that your server is using the latest supported version and for more information about SPP, see the HP website (<http://www.hp.com/go/spp/download>).

To locate the drivers for a particular server, go to the HP website (<http://www.hp.com/go/hpsc>) and click on **Drivers, Software & Firmware**. Then, enter your product name in the **Find an HP product** field and click **Go**.

## Software and firmware

Software and firmware should be updated before using the server for the first time, unless any installed software or components require an older version.

For system software and firmware updates, use one of the following sources:

- Download the SPP ("HP Service Pack for ProLiant" on page 90) from the HP Service Pack for ProLiant download page (<http://www.hp.com/go/spp>).
- Download individual drivers, firmware, or other systems software components from the server product page in the HP Support Center (<http://www.hp.com/go/hpsc>).

## Operating System Version Support

For information about specific versions of a supported operating system, refer to the operating system support matrix (<http://www.hp.com/go/supportos>).

## Version control

The VCRM and VCA are web-enabled Insight Management Agents tools that HP SIM uses to schedule software update tasks to the entire enterprise.

- VCRM manages the repository for SPP. Administrators can view the SPP contents or configure VCRM to automatically update the repository with internet downloads of the latest software and firmware from HP.
- VCA compares installed software versions on the node with updates available in the VCRM managed repository. Administrators configure VCA to point to a repository managed by VCRM.

For more information about version control tools, see the *HP Systems Insight Manager User Guide*, the *HP Version Control Agent User Guide*, and the *HP Version Control Repository Manager User Guide* on the HP website (<http://www.hp.com/go/enterprise/docs>).

1. Select **HP Insight Management** from the available options in Products and Solutions.
2. Select **HP Version Control** from the available options in HP Insight Management.
3. Download the latest document.

## HP operating systems and virtualization software support for ProLiant servers

For information about specific versions of a supported operating system, see the HP website (<http://www.hp.com/go/ossupport>).

## HP Technology Service Portfolio

Connect to HP for assistance on the journey to the new style of IT. HP Technology Services delivers confidence and reduces risk to help you realize agility and stability in your IT infrastructure.

Utilize our consulting expertise in the areas of private or hybrid cloud computing, big data and mobility requirements, improving data center infrastructure and better use of today's server, storage and networking technology. For more information, see the HP website (<http://www.hp.com/services/consulting>).

Our support portfolio covers services for HP server, storage and networking hardware and software plus the leading industry standard operating systems. Let us work proactively with you to prevent problems. Our flexible choices of hardware and software support coverage windows and response times help resolve problems faster, reduce unplanned outages and free your staff for more important tasks. For more information, see the HP website (<http://www.hp.com/services/support>).

Tap into our knowledge, expertise, innovation and world-class services to achieve better results. Access and apply technology in new ways to optimize your operations and you'll be positioned for success.

## Change control and proactive notification

HP offers Change Control and Proactive Notification to notify customers 30 to 60 days in advance of upcoming hardware and software changes on HP commercial products.

For more information, refer to the HP website (<http://www.hp.com/go/pcn>).

---

# Troubleshooting

## Troubleshooting resources

The *HP ProLiant Gen9 Troubleshooting Guide, Volume I: Troubleshooting* provides procedures for resolving common problems and comprehensive courses of action for fault isolation and identification, issue resolution, and software maintenance on ProLiant servers and server blades. To view the guide, select a language:

- English ([http://www.hp.com/support/Gen9\\_TSG\\_en](http://www.hp.com/support/Gen9_TSG_en))
- French ([http://www.hp.com/support/Gen9\\_TSG\\_fr](http://www.hp.com/support/Gen9_TSG_fr))
- Spanish ([http://www.hp.com/support/Gen9\\_TSG\\_es](http://www.hp.com/support/Gen9_TSG_es))
- German ([http://www.hp.com/support/Gen9\\_TSG\\_de](http://www.hp.com/support/Gen9_TSG_de))
- Japanese ([http://www.hp.com/support/Gen9\\_TSG\\_ja](http://www.hp.com/support/Gen9_TSG_ja))
- Simplified Chinese ([http://www.hp.com/support/Gen9\\_TSG\\_zh\\_cn](http://www.hp.com/support/Gen9_TSG_zh_cn))

The *HP ProLiant Gen9 Troubleshooting Guide, Volume II: Error Messages* provides a list of error messages and information to assist with interpreting and resolving error messages on ProLiant servers and server blades. To view the guide, select a language:

- English ([http://www.hp.com/support/Gen9\\_EMG\\_en](http://www.hp.com/support/Gen9_EMG_en))
- French ([http://www.hp.com/support/Gen9\\_EMG\\_fr](http://www.hp.com/support/Gen9_EMG_fr))
- Spanish ([http://www.hp.com/support/Gen9\\_EMG\\_es](http://www.hp.com/support/Gen9_EMG_es))
- German ([http://www.hp.com/support/Gen9\\_EMG\\_de](http://www.hp.com/support/Gen9_EMG_de))
- Japanese ([http://www.hp.com/support/Gen9\\_EMG\\_ja](http://www.hp.com/support/Gen9_EMG_ja))
- Simplified Chinese ([http://www.hp.com/support/Gen9\\_EMG\\_zh\\_cn](http://www.hp.com/support/Gen9_EMG_zh_cn))

# System battery replacement

If the server no longer automatically displays the correct date and time, then replace the battery that provides power to the real-time clock. Under normal use, battery life is 5 to 10 years.



**WARNING:** The computer contains an internal lithium manganese dioxide, a vanadium pentoxide, or an alkaline battery pack. A risk of fire and burns exists if the battery pack is not properly handled. To reduce the risk of personal injury:

- Do not attempt to recharge the battery.
- Do not expose the battery to temperatures higher than 60°C (140°F).
- Do not disassemble, crush, puncture, short external contacts, or dispose of in fire or water.
- Replace only with the spare designated for this product.

To remove the component:

1. Power down the server (on page 17).
2. Remove all power:
  - a. Disconnect each power cord from the power source.
  - b. Disconnect each power cord from the server.
3. Do one of the following:
  - o Extend the server from the rack (on page 17).
  - o Remove the server from the rack (on page 18).
4. Remove the access panel (on page 19).
5. Remove the secondary PCI riser cage. ("Remove the PCI riser cage" on page 22)
6. If installed, remove any expansion board ("Expansion board options" on page 63) installed in slot 1.
7. Locate the battery on the system board.
8. Remove the battery.

Use a small flat-bladed, nonconductive tool to carefully remove the battery from the socket.



**WARNING:** Do not exert too much force to remove the system battery. The battery could pop out of the socket, or the tool could slip and damage the socket or the system board.

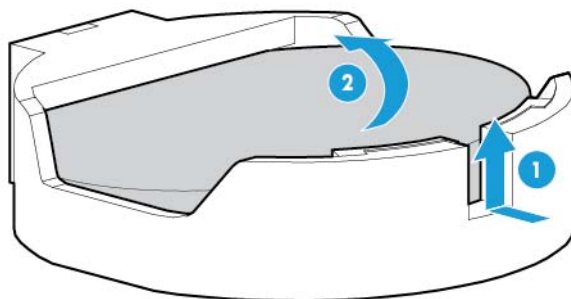



---

**IMPORTANT:** Replacing the system board battery resets the system ROM to its default configuration. After replacing the battery, use BIOS/Platform Configuration (RBSU) in the UEFI System Utilities ("[HP UEFI System Utilities](#)" on page 91) to reconfigure the system.

---

To replace the component:

1. Insert the battery with the "+" side facing up underneath the outer lip of the socket, and then press the battery down to secure it in place.

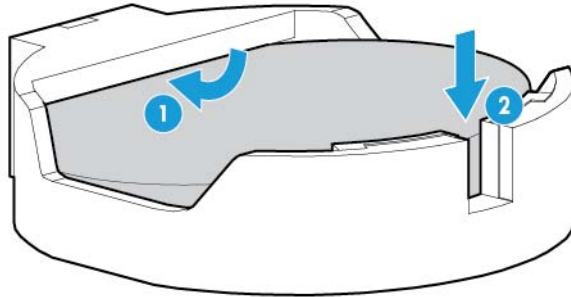

2. Install the access panel (on page 20).
3. Do one of the following:
  - o Slide the server into the rack.
  - o Install the server into the rack ("[Installing the server into the rack](#)" on page 30).
4. Power up the server (on page 17).

For more information about battery replacement or proper disposal, contact an authorized reseller or an authorized service provider.

---

# Regulatory information

## Safety and regulatory compliance

For safety, environmental, and regulatory information, see *Safety and Compliance Information for Server, Storage, Power, Networking, and Rack Products*, available at the HP website (<http://www.hp.com/support/Safety-Compliance-EnterpriseProducts>).

## Belarus Kazakhstan Russia marking



### Manufacturer

Hewlett-Packard Company, Address: 3000 Hanover Street, Palo Alto, California 94304, U.S.

### Local representative information (Russian)

- HP Russia  
ЗАО «Хьюлетт-Паккард А.О.», 125171, Россия, г. Москва, Ленинградское шоссе, 16А, стр.3, тел./факс: +7 (495) 797 35 00, +7 (495) 287 89 05
- HP Belarus  
ИООО «Хьюлетт-Паккард Бел», 220030, Беларусь, г. Минск, ул. Интернациональная, 36-1, офис 722-723, тел.: +375 (17) 392 28 18, факс: +375 (17) 392 28 21
- HP Kazakhstan  
ТОО «Хьюлетт-Паккард (К)», 050040, Казахстан, г. Алматы, Бостандықский район, ул. Тимирязева, 28В, 1 этаж, тел./факс: +7 (727) 355 35 50, +7 (727) 355 35 51

### Local representative information (Kazakh)

ЖШС «Хьюлетт-Паккард (К)», Қазақстан, Алматы қ., Бостандық ауданы, Тимирязев к-сі, 28В, тел./факс: +7 (727) 355 35 50, +7 (727) 355 35 51

### Manufacturing date

The manufacturing date is defined by the serial number (HP serial number format for this product):

CCSYWWZZZZ

Valid date formats include the following:

- YWW, where Y indicates the year counting from within each new decade, with 2000 as the starting point. For example, 238: 2 for 2002 and 38 for the week of September 9. In addition, 2010 is indicated by 0, 2011 by 1, 2012 by 2, 2013 by 3, and so forth.
- YYWW, where YY indicates the year, using a base year of 2000. For example, 0238: 02 for 2002 and 38 for the week of September 9.

## Turkey RoHS material content declaration

Türkiye Cumhuriyeti: EEE Yönetmeliğine Uygundur

## Ukraine RoHS material content declaration

Обладнання відповідає вимогам Технічного регламенту щодо обмеження використання деяких небезпечних речовин в електричному та електронному обладнанні, затвердженого постановою Кабінету Міністрів України від 3 грудня 2008 № 1057

## Warranty information

HP ProLiant and X86 Servers and Options (<http://www.hp.com/support/ProLiantServers-Warranties>)

HP Enterprise Servers (<http://www.hp.com/support/EnterpriseServers-Warranties>)

HP Storage Products (<http://www.hp.com/support/Storage-Warranties>)

HP Networking Products (<http://www.hp.com/support/Networking-Warranties>)



---

# Electrostatic discharge

## Preventing electrostatic discharge

To prevent damaging the system, be aware of the precautions you need to follow when setting up the system or handling parts. A discharge of static electricity from a finger or other conductor may damage system boards or other static-sensitive devices. This type of damage may reduce the life expectancy of the device.

To prevent electrostatic damage:

- Avoid hand contact by transporting and storing products in static-safe containers.
- Keep electrostatic-sensitive parts in their containers until they arrive at static-free workstations.
- Place parts on a grounded surface before removing them from their containers.
- Avoid touching pins, leads, or circuitry.
- Always be properly grounded when touching a static-sensitive component or assembly.

## Grounding methods to prevent electrostatic discharge

Several methods are used for grounding. Use one or more of the following methods when handling or installing electrostatic-sensitive parts:

- Use a wrist strap connected by a ground cord to a grounded workstation or computer chassis. Wrist straps are flexible straps with a minimum of 1 megohm  $\pm 10$  percent resistance in the ground cords. To provide proper ground, wear the strap snug against the skin.
- Use heel straps, toe straps, or boot straps at standing workstations. Wear the straps on both feet when standing on conductive floors or dissipating floor mats.
- Use conductive field service tools.
- Use a portable field service kit with a folding static-dissipating work mat.

If you do not have any of the suggested equipment for proper grounding, have an authorized reseller install the part.

For more information on static electricity or assistance with product installation, contact an authorized reseller.

# Specifications

## Environmental specifications

Specification	Value
<b>Temperature range*</b>	—
Operating	10°C to 35°C (50°F to 95°F)
Nonoperating	-30°C to 60°C (-22°F to 140°F)
<b>Relative humidity (noncondensing)</b>	—
Operating	Minimum to be the higher (more moisture) of -12°C (10.4°F) dew point or 8% relative humidity Maximum to be 24°C (75.2°F) dew point or 90% relative humidity
Nonoperating	5% to 95% 38.7°C (101.7°F), maximum wet bulb temperature

\* All temperature ratings shown are for sea level. An altitude derating of 1.0°C per 304.8 m (1.8°F per 1000 ft) to 3048 m (10,000 ft) is applicable. No direct sunlight allowed. Maximum rate of change is 20°C per hour (36°F per hour). The upper limit and rate of change might be limited by the type and number of options installed.

For certain approved hardware configurations, the supported system inlet temperature range is extended:

- 5°C to 10°C (41°F to 50°F) and 35°C to 40°C (95°F to 104°F) at sea level with an altitude derating of 1.0°C per every 175 m (1.8°F per every 574 ft) above 900 m (2953 ft) to a maximum of 3048 m (10,000 ft).
- 40°C to 45°C (104°F to 113°F) at sea level with an altitude derating of 1.0°C per every 125 m (1.8°F per every 410 ft) above 900 m (2953 ft) to a maximum of 3048 m (10,000 ft).

The approved hardware configurations for this system are listed on the HP website (<http://www.hp.com/servers/ASHRAE>).

## Mechanical specifications

Specification	Value
Height	4.29 cm (1.69 in)
Depth	60.70 cm (23.90 in)
Width	43.46 cm (17.11 in)
Weight (approximate range)	9.00 kg to 17.00 kg (19.82 lb to 37.44 lb)

# Power supply specifications

Depending on the installed options and/or the regional location where the server was purchased, the server is configured with one of the following power supplies:

- HP 550-W Power Supply (PN 730941-B21)
- HP 800-W/900-W Gold AC Power Input Module (PN 744689-B21) This module is supported when the two-bay HP RPS backplane option (PN 745813-B21) is installed.

For more information about the power supply features, specifications, and compatibility, see the HP website (<http://www.hp.com/go/proliant/powersupply>).



**CAUTION:** Check the system and power supply input ratings before powering up the server.

---

# Hot-plug power supply calculations

For hot-plug power supply specifications and calculators to determine electrical and heat loading for the server, see the HP Power Advisor website (<http://www.hp.com/go/hppoweradvisor>).

---

# Support and other resources

## Before you contact HP

Be sure to have the following information available before you call HP:

- Active Health System log (HP ProLiant Gen8 or later products)  
Download and have available an Active Health System log for 7 days before the failure was detected. For more information, see the *HP iLO 4 User Guide* or *HP Intelligent Provisioning User Guide* on the HP website (<http://www.hp.com/go/ilo/docs>).
- Onboard Administrator SHOW ALL report (for HP BladeSystem products only)  
For more information on obtaining the Onboard Administrator SHOW ALL report, see the HP website (<http://www.hp.com/go/OAlog>).
- Technical support registration number (if applicable)
- Product serial number
- Product model name and number
- Product identification number
- Applicable error messages
- Add-on boards or hardware
- Third-party hardware or software
- Operating system type and revision level

## HP contact information

For United States and worldwide contact information, see the Contact HP website (<http://www.hp.com/go/assistance>).

In the United States:

- To contact HP by phone, call 1-800-334-5144. For continuous quality improvement, calls may be recorded or monitored.
- If you have purchased a Care Pack (service upgrade), see the Support & Drivers website (<http://www8.hp.com/us/en/support-drivers.html>). If the problem cannot be resolved at the website, call 1-800-633-3600. For more information about Care Packs, see the HP website (<http://pro-aq-sama.houston.hp.com/services/cache/10950-0-0-225-121.html>).

## Customer Self Repair

HP products are designed with many Customer Self Repair (CSR) parts to minimize repair time and allow for greater flexibility in performing defective parts replacement. If during the diagnosis period HP (or HP service

providers or service partners) identifies that the repair can be accomplished by the use of a CSR part, HP will ship that part directly to you for replacement. There are two categories of CSR parts:

- **Mandatory**—Parts for which customer self repair is mandatory. If you request HP to replace these parts, you will be charged for the travel and labor costs of this service.
- **Optional**—Parts for which customer self repair is optional. These parts are also designed for customer self repair. If, however, you require that HP replace them for you, there may or may not be additional charges, depending on the type of warranty service designated for your product.

**NOTE:** Some HP parts are not designed for customer self repair. In order to satisfy the customer warranty, HP requires that an authorized service provider replace the part. These parts are identified as "No" in the Illustrated Parts Catalog.

Based on availability and where geography permits, CSR parts will be shipped for next business day delivery. Same day or four-hour delivery may be offered at an additional charge where geography permits. If assistance is required, you can call the HP Technical Support Center and a technician will help you over the telephone. HP specifies in the materials shipped with a replacement CSR part whether a defective part must be returned to HP. In cases where it is required to return the defective part to HP, you must ship the defective part back to HP within a defined period of time, normally five (5) business days. The defective part must be returned with the associated documentation in the provided shipping material. Failure to return the defective part may result in HP billing you for the replacement. With a customer self repair, HP will pay all shipping and part return costs and determine the courier/carrier to be used.

For more information about HP's Customer Self Repair program, contact your local service provider. For the North American program, refer to the HP website (<http://www.hp.com/go/selfrepair>).

## Réparation par le client (CSR)

Les produits HP comportent de nombreuses pièces CSR (Customer Self Repair = réparation par le client) afin de minimiser les délais de réparation et faciliter le remplacement des pièces défectueuses. Si pendant la période de diagnostic, HP (ou ses partenaires ou mainteneurs agréés) détermine que la réparation peut être effectuée à l'aide d'une pièce CSR, HP vous l'envoie directement. Il existe deux catégories de pièces CSR:

Obligatoire - Pièces pour lesquelles la réparation par le client est obligatoire. Si vous demandez à HP de remplacer ces pièces, les coûts de déplacement et main d'œuvre du service vous seront facturés.

Facultatif - Pièces pour lesquelles la réparation par le client est facultative. Ces pièces sont également conçues pour permettre au client d'effectuer lui-même la réparation. Toutefois, si vous demandez à HP de remplacer ces pièces, l'intervention peut ou non vous être facturée, selon le type de garantie applicable à votre produit.

**REMARQUE:** Certaines pièces HP ne sont pas conçues pour permettre au client d'effectuer lui-même la réparation. Pour que la garantie puisse s'appliquer, HP exige que le remplacement de la pièce soit effectué par un Mainteneur Agréé. Ces pièces sont identifiées par la mention "Non" dans le Catalogue illustré.

Les pièces CSR sont livrées le jour ouvré suivant, dans la limite des stocks disponibles et selon votre situation géographique. Si votre situation géographique le permet et que vous demandez une livraison le jour même ou dans les 4 heures, celle-ci vous sera facturée. Pour bénéficier d'une assistance téléphonique, appelez le Centre d'assistance technique HP. Dans les documents envoyés avec la pièce de rechange CSR, HP précise s'il est nécessaire de lui retourner la pièce défectueuse. Si c'est le cas, vous devez le faire dans le délai indiqué, généralement cinq (5) jours ouvrés. La pièce et sa documentation doivent être retournées dans l'emballage fourni. Si vous ne retournez pas la pièce défectueuse, HP se réserve le droit de vous facturer les coûts de remplacement. Dans le cas d'une pièce CSR, HP supporte l'ensemble des frais d'expédition et de retour, et détermine la société de courses ou le transporteur à utiliser.

Pour plus d'informations sur le programme CSR de HP, contactez votre Mainteneur Agréé local. Pour plus d'informations sur ce programme en Amérique du Nord, consultez le site Web HP (<http://www.hp.com/go/selfrepair>).

## Riparazione da parte del cliente

Per abbreviare i tempi di riparazione e garantire una maggiore flessibilità nella sostituzione di parti difettose, i prodotti HP sono realizzati con numerosi componenti che possono essere riparati direttamente dal cliente (CSR, Customer Self Repair). Se in fase di diagnostica HP (o un centro di servizi o di assistenza HP) identifica il guasto come riparabile mediante un ricambio CSR, HP lo spedisce direttamente al cliente per la sostituzione. Vi sono due categorie di parti CSR:

**Obbligatorie** – Parti che devono essere necessariamente riparate dal cliente. Se il cliente ne affida la riparazione ad HP, deve sostenere le spese di spedizione e di manodopera per il servizio.

**Opzionali** – Parti la cui riparazione da parte del cliente è facoltativa. Si tratta comunque di componenti progettati per questo scopo. Se tuttavia il cliente ne richiede la sostituzione ad HP, potrebbe dover sostenere spese aggiuntive a seconda del tipo di garanzia previsto per il prodotto.

**NOTA:** alcuni componenti HP non sono progettati per la riparazione da parte del cliente. Per rispettare la garanzia, HP richiede che queste parti siano sostituite da un centro di assistenza autorizzato. Tali parti sono identificate da un "No" nel Catalogo illustrato dei componenti.

In base alla disponibilità e alla località geografica, le parti CSR vengono spedite con consegna entro il giorno lavorativo seguente. La consegna nel giorno stesso o entro quattro ore è offerta con un supplemento di costo solo in alcune zone. In caso di necessità si può richiedere l'assistenza telefonica di un addetto del centro di supporto tecnico HP. Nel materiale fornito con una parte di ricambio CSR, HP specifica se il cliente deve restituire dei componenti. Qualora sia richiesta la resa ad HP del componente difettoso, lo si deve spedire ad HP entro un determinato periodo di tempo, generalmente cinque (5) giorni lavorativi. Il componente difettoso deve essere restituito con la documentazione associata nell'imballo di spedizione fornito. La mancata restituzione del componente può comportare la fatturazione del ricambio da parte di HP. Nel caso di riparazione da parte del cliente, HP sostiene tutte le spese di spedizione e resa e sceglie il corriere/vettore da utilizzare.

Per ulteriori informazioni sul programma CSR di HP contattare il centro di assistenza di zona. Per il programma in Nord America fare riferimento al sito Web HP (<http://www.hp.com/go/selfrepair>).

## Customer Self Repair

HP Produkte enthalten viele CSR-Teile (Customer Self Repair), um Reparaturzeiten zu minimieren und höhere Flexibilität beim Austausch defekter Bauteile zu ermöglichen. Wenn HP (oder ein HP Servicepartner) bei der Diagnose feststellt, dass das Produkt mithilfe eines CSR-Teils repariert werden kann, sendet Ihnen HP dieses Bauteil zum Austausch direkt zu. CSR-Teile werden in zwei Kategorien unterteilt:

**Zwingend** – Teile, für die das Customer Self Repair-Verfahren zwingend vorgegeben ist. Wenn Sie den Austausch dieser Teile von HP vornehmen lassen, werden Ihnen die Anfahrt- und Arbeitskosten für diesen Service berechnet.

**Optional** – Teile, für die das Customer Self Repair-Verfahren optional ist. Diese Teile sind auch für Customer Self Repair ausgelegt. Wenn Sie jedoch den Austausch dieser Teile von HP vornehmen lassen möchten, können bei diesem Service je nach den für Ihr Produkt vorgesehenen Garantiebedingungen zusätzliche Kosten anfallen.

**HINWEIS:** Einige Teile sind nicht für Customer Self Repair ausgelegt. Um den Garantieanspruch des Kunden zu erfüllen, muss das Teil von einem HP Servicepartner ersetzt werden. Im illustrierten Teilekatalog sind diese Teile mit „No“ bzw. „Nein“ gekennzeichnet.

CSR-Teile werden abhängig von der Verfügbarkeit und vom Lieferziel am folgenden Geschäftstag geliefert. Für bestimmte Standorte ist eine Lieferung am selben Tag oder innerhalb von vier Stunden gegen einen Aufpreis verfügbar. Wenn Sie Hilfe benötigen, können Sie das HP technische Support Center anrufen und sich von einem Mitarbeiter per Telefon helfen lassen. Den Materialien, die mit einem CSR-Ersatzteil geliefert werden, können Sie entnehmen, ob das defekte Teil an HP zurückgeschickt werden muss. Wenn es erforderlich ist, das defekte Teil an HP zurückzuschicken, müssen Sie dies innerhalb eines vorgegebenen Zeitraums tun, in der Regel innerhalb von fünf (5) Geschäftstagen. Das defekte Teil muss mit der zugehörigen Dokumentation in der Verpackung zurückgeschickt werden, die im Lieferumfang enthalten ist. Wenn Sie das defekte Teil nicht zurückschicken, kann HP Ihnen das Ersatzteil in Rechnung stellen. Im Falle von Customer Self Repair kommt HP für alle Kosten für die Lieferung und Rücksendung auf und bestimmt den Kurier-/Frachtdienst.

Weitere Informationen über das HP Customer Self Repair Programm erhalten Sie von Ihrem Servicepartner vor Ort. Informationen über das CSR-Programm in Nordamerika finden Sie auf der HP Website unter (<http://www.hp.com/go/selfrepair>).

## Reparaciones del propio cliente

Los productos de HP incluyen muchos componentes que el propio usuario puede reemplazar (*Customer Self Repair*, CSR) para minimizar el tiempo de reparación y ofrecer una mayor flexibilidad a la hora de realizar sustituciones de componentes defectuosos. Si, durante la fase de diagnóstico, HP (o los proveedores o socios de servicio de HP) identifica que una reparación puede llevarse a cabo mediante el uso de un componente CSR, HP le enviará dicho componente directamente para que realice su sustitución. Los componentes CSR se clasifican en dos categorías:

- **Obligatorio:** componentes para los que la reparación por parte del usuario es obligatoria. Si solicita a HP que realice la sustitución de estos componentes, tendrá que hacerse cargo de los gastos de desplazamiento y de mano de obra de dicho servicio.
- **Opcional:** componentes para los que la reparación por parte del usuario es opcional. Estos componentes también están diseñados para que puedan ser reparados por el usuario. Sin embargo, si precisa que HP realice su sustitución, puede o no conllevar costes adicionales, dependiendo del tipo de servicio de garantía correspondiente al producto.

**NOTA:** Algunos componentes no están diseñados para que puedan ser reparados por el usuario. Para que el usuario haga valer su garantía, HP pone como condición que un proveedor de servicios autorizado realice la sustitución de estos componentes. Dichos componentes se identifican con la palabra "No" en el catálogo ilustrado de componentes.

Según la disponibilidad y la situación geográfica, los componentes CSR se enviarán para que lleguen a su destino al siguiente día laborable. Si la situación geográfica lo permite, se puede solicitar la entrega en el mismo día o en cuatro horas con un coste adicional. Si precisa asistencia técnica, puede llamar al Centro de asistencia técnica de HP y recibirá ayuda telefónica por parte de un técnico. Con el envío de materiales para la sustitución de componentes CSR, HP especificará si los componentes defectuosos deberán devolverse a HP. En aquellos casos en los que sea necesario devolver algún componente a HP, deberá hacerlo en el periodo de tiempo especificado, normalmente cinco días laborables. Los componentes defectuosos deberán devolverse con toda la documentación relacionada y con el embalaje de envío. Si no enviara el componente defectuoso requerido, HP podrá cobrarle por el de sustitución. En el caso de todas

sustituciones que lleve a cabo el cliente, HP se hará cargo de todos los gastos de envío y devolución de componentes y escogerá la empresa de transporte que se utilice para dicho servicio.

Para obtener más información acerca del programa de Reparaciones del propio cliente de HP, póngase en contacto con su proveedor de servicios local. Si está interesado en el programa para Norteamérica, visite la página web de HP siguiente (<http://www.hp.com/go/selfrepair>).

## Customer Self Repair

Veel onderdelen in HP producten zijn door de klant zelf te repareren, waardoor de reparatieduur tot een minimum beperkt kan blijven en de flexibiliteit in het vervangen van defecte onderdelen groter is. Deze onderdelen worden CSR-onderdelen (Customer Self Repair) genoemd. Als HP (of een HP Service Partner) bij de diagnose vaststelt dat de reparatie kan worden uitgevoerd met een CSR-onderdeel, verzendt HP dat onderdeel rechtstreeks naar u, zodat u het defecte onderdeel daarmee kunt vervangen. Er zijn twee categorieën CSR-onderdelen:

**Verplicht:** Onderdelen waarvoor reparatie door de klant verplicht is. Als u HP verzoekt deze onderdelen voor u te vervangen, worden u voor deze service reiskosten en arbeidsloon in rekening gebracht.

**Optioneel:** Onderdelen waarvoor reparatie door de klant optioneel is. Ook deze onderdelen zijn ontworpen voor reparatie door de klant. Als u echter HP verzoekt deze onderdelen voor u te vervangen, kunnen daarvoor extra kosten in rekening worden gebracht, afhankelijk van het type garanteservice voor het product.

**OPMERKING:** Sommige HP onderdelen zijn niet ontwikkeld voor reparatie door de klant. In verband met de garantievoorwaarden moet het onderdeel door een geautoriseerde Service Partner worden vervangen. Deze onderdelen worden in de geïllustreerde onderdelencatalogus aangemerkt met "Nee".

Afhankelijk van de leverbaarheid en de locatie worden CSR-onderdelen verzonden voor levering op de eerstvolgende werkdag. Levering op dezelfde dag of binnen vier uur kan tegen meerkosten worden aangeboden, indien dit mogelijk is gezien de locatie. Indien assistentie gewenst is, belt u een HP Service Partner om via de telefoon technische ondersteuning te ontvangen. HP vermeldt in de documentatie bij het vervangende CSR-onderdeel of het defecte onderdeel aan HP moet worden geretourneerd. Als het defecte onderdeel aan HP moet worden teruggezonden, moet u het defecte onderdeel binnen een bepaalde periode, gewoonlijk vijf (5) werkdagen, retourneren aan HP. Het defecte onderdeel moet met de bijbehorende documentatie worden geretourneerd in het meegeleverde verpakkingsmateriaal. Als u het defecte onderdeel niet terugzendt, kan HP u voor het vervangende onderdeel kosten in rekening brengen. Bij reparatie door de klant betaalt HP alle verzendkosten voor het vervangende en geretourneerde onderdeel en kiest HP zelf welke koerier/transportonderneming hiervoor wordt gebruikt.

Neem contact op met een Service Partner voor meer informatie over het Customer Self Repair programma van HP. Informatie over Service Partners vindt u op de HP website (<http://www.hp.com/go/selfrepair>).

## Reparo feito pelo cliente

Os produtos da HP são projetados com muitas peças para reparo feito pelo cliente (CSR) de modo a minimizar o tempo de reparo e permitir maior flexibilidade na substituição de peças com defeito. Se, durante o período de diagnóstico, a HP (ou fornecedores/parceiros de serviço da HP) concluir que o reparo pode ser efetuado pelo uso de uma peça CSR, a peça de reposição será enviada diretamente ao cliente. Existem duas categorias de peças CSR:

**Obrigatória** – Peças cujo reparo feito pelo cliente é obrigatório. Se desejar que a HP substitua essas peças, serão cobradas as despesas de transporte e mão-de-obra do serviço.



Opcional – Peças cujo reparo feito pelo cliente é opcional. Essas peças também são projetadas para o reparo feito pelo cliente. No entanto, se desejar que a HP as substitua, pode haver ou não a cobrança de taxa adicional, dependendo do tipo de serviço de garantia destinado ao produto.

**OBSERVAÇÃO:** Algumas peças da HP não são projetadas para o reparo feito pelo cliente. A fim de cumprir a garantia do cliente, a HP exige que um técnico autorizado substitua a peça. Essas peças estão identificadas com a marca "No" (Não), no catálogo de peças ilustrado.

Conforme a disponibilidade e o local geográfico, as peças CSR serão enviadas no primeiro dia útil após o pedido. Onde as condições geográficas permitirem, a entrega no mesmo dia ou em quatro horas pode ser feita mediante uma taxa adicional. Se precisar de auxílio, entre em contato com o Centro de suporte técnico da HP para que um técnico o ajude por telefone. A HP especifica nos materiais fornecidos com a peça CSR de reposição se a peça com defeito deve ser devolvida à HP. Nos casos em que isso for necessário, é preciso enviar a peça com defeito à HP dentro do período determinado, normalmente cinco (5) dias úteis. A peça com defeito deve ser enviada com a documentação correspondente no material de transporte fornecido. Caso não o faça, a HP poderá cobrar a reposição. Para as peças de reparo feito pelo cliente, a HP paga todas as despesas de transporte e de devolução da peça e determina a transportadora/serviço postal a ser utilizado.

Para obter mais informações sobre o programa de reparo feito pelo cliente da HP, entre em contato com o fornecedor de serviços local. Para o programa norte-americano, visite o site da HP (<http://www.hp.com/go/selfrepair>).

## カスタマーセルフリペア

修理時間を短縮し、故障部品の交換における高い柔軟性を確保するために、HP製品には多数のCSR部品があります。診断の際に、CSR部品を使用すれば修理ができるとHP（HPまたはHP正規保守代理店）が判断した場合、HPはその部品を直接、お客様に発送し、お客様に交換していただきます。CSR部品には以下の2通りがあります。

- **必須** - カスタマーセルフリペアが必須の部品。当該部品について、もしもお客様がHPに交換作業を依頼される場合には、その修理サービスに関する交通費および人件費がお客様に請求されます。
- **任意** - カスタマーセルフリペアが任意である部品。この部品もカスタマーセルフリペア用です。当該部品について、もしもお客様がHPに交換作業を依頼される場合には、お買い上げの製品に適用される保証サービス内容の範囲内においては、別途費用を負担していただくことなく保証サービスを受けることができます。

**注：** HP製品の一部の部品は、カスタマーセルフリペア用ではありません。製品の保証を継続するためには、HPまたはHP正規保守代理店による交換作業が必須となります。部品カタログには、当該部品がカスタマーセルフリペア除外品である旨が記載されています。

部品供給が可能な場合、地域によっては、CSR部品を翌営業日に届くように発送します。また、地域によっては、追加費用を負担いただくことにより同日または4時間以内に届くように発送することも可能な場合があります。サポートが必要なときは、HPの修理受付窓口へ電話していただければ、技術者が電話でアドバイスします。交換用のCSR部品または同梱物には、故障部品をHPに返送する必要があるかどうかが表示されています。故障部品をHPに返送する必要がある場合は、指定期限内（通常は5営業日以内）に故障部品をHPに返送してください。故障部品を返送する場合は、届いた時の梱包箱に関連書類とともに入れてください。故障部品を返送しない場合、HPから部品費用が請求されます。カスタマーセルフリペアの際には、HPは送料および部品返送費を全額負担し、使用する宅配便会社や運送会社を指定します。

## 客戶自行維修

HP 產品提供許多客戶自行維修 (CSR) 部件，以尽可能縮短維修時間和在更換缺陷部件方面提供更大的靈活性。如果在診斷期間 HP (或 HP 服務提供商或服務合作夥伴) 確定可以通過使用 CSR 部件完成維修，HP 將直接把該部件發送給您進行更換。有兩類 CSR 部件：

- **強制性的** — 要求客戶必須自行維修的部件。如果您請求 HP 更換這些部件，則必須為該服務支付差旅費和人工費用。
- **可選的** — 客戶可以選擇是否自行維修的部件。這些部件也是為客戶自行維修設計的。不過，如果您要求 HP 為您更換這些部件，則根據為您的產品指定的保修服務類型，HP 可能收取或不再收取任何附加費用。

**注：**某些 HP 部件的設計並未考慮客戶自行維修。為了滿足客戶保修的需要，HP 要求授權服務提供商更換相關部件。這些部件在部件圖解目錄中標記為“否”。

CSR 部件將在下一個工作日發運（取決於備貨情況和允許的地理範圍）。在允許的地理範圍內，可在當天或四小時內發運，但要收取額外費用。如果需要幫助，您可以致電 HP 技術支持中心，將會有技術人員通過電話為您提供幫助。HP 會在隨更換的 CSR 部件發運的材料中指明是否必須將有缺陷的部件返還給 HP。如果要求您將有缺陷的部件返還給 HP，那麼您必須在規定期限內（通常是五 (5) 個工作日）將缺陷部件發給 HP。有缺陷的部件必須隨所提供的發運材料中的相關文件一起返還。如果未能送還有缺陷的部件，HP 可能會要求您支付更換費用。客戶自行維修時，HP 將承擔所有相關運輸和部件返回費用，並指定快遞商/承運商。

有關 HP 客戶自行維修計劃的詳細信息，請與您當地的服務提供商聯繫。有關北美地區的計劃，請訪問 HP 網站 (<http://www.hp.com/go/selfrepair>)。

## 客戶自行維修

HP 產品設計了許多「客戶自行維修」(CSR) 的零件以減少維修時間，並且使得更換瑕疵零件時能有更大的彈性。如果在診斷期間 HP (或 HP 服務供應商或維修夥伴) 辨認出此項維修工作可以藉由使用 CSR 零件來完成，則 HP 將直接寄送該零件給您作更換。CSR 零件分為兩種類別：

- **強制的** — 客戶自行維修所使用的零件是強制的。如果您要求 HP 更換這些零件，HP 將會向您收取此服務所需的外出費用與勞動成本。
- **選購的** — 客戶自行維修所使用的零件是選購的。這些零件也設計用於客戶自行維修之用。不過，如果您要求 HP 為您更換，則可能需要也可能不需要負擔額外的費用，端視針對此產品指定的保固服務類型而定。

**備註：**某些 HP 零件沒有消費者可自行維修的設計。為符合客戶保固，HP 需要授權的服務供應商更換零件。這些零件在圖示的零件目錄中，被標示為「否」。

基於材料取得及環境允許的情況下，CSR 零件將於下一個工作日以快遞寄送。在環境的允許下當天或四小時內送達，則可能需要額外的費用。若您需要協助，可致電「HP 技術支援中心」，會有一位技術人員透過電話來協助您。不論損壞的零件是否必須退回，HP 皆會在與 CSR 替換零件一起運送的材料中註明。若要將損壞的零件退回 HP，您必須在指定的一段時間內（通常為五 (5) 個工作天），將損壞的零件寄回 HP。損壞的零件必須與寄送資料中隨附的相關技術文件一併退還。如果無法退還損壞的零件，HP 可能要向您收取替換費用。針對客戶自行維修情形，HP 將負責所有運費及零件退還費用並指定使用何家快遞/貨運公司。

如需 HP 的「客戶自行維修」方案詳細資訊，請連絡您當地的服務供應商。至於北美方案，請參閱 HP 網站 (<http://www.hp.com/go/selfrepair>)。

## 고객 셀프 수리

HP 제품은 수리 시간을 최소화하고 결함이 있는 부품 교체 시 더욱 용통성을 발휘할 수 있도록 하기 위해 고객 셀프 수리(CSR) 부품을 다량 사용하여 설계되었습니다. 진단 기간 동안 HP(또는 HP 서비스 공급업체 또는 서비스 협력업체)에서 CSR 부품을 사용하여 수리가 가능하다고 판단되면 HP는 해당 부품을 바로 사용자에게 보내어 사용자가 교체할 수 있도록 합니다. CSR 부품에는 두 가지 종류가 있습니다.

- **고객 셀프 수리가 의무 사항인 필수 부품.** 사용자가 HP에 이 부품의 교체를 요청할 경우 이 서비스에 대한 출장비 및 작업비가 청구됩니다.
- **고객 셀프 수리가 선택 사항인 부품.** 이 부품들도 고객 셀프 수리가 가능하도록 설계되었습니다. 하지만 사용자가 HP에 이 부품의 교체를 요청할 경우 사용자가 구입한 제품에 해당하는 보증 서비스 유형에 따라 추가 비용 없이 교체가 가능할 수 있습니다.

**참고:** 일부 HP 부품은 고객 셀프 수리가 불가능하도록 설계되었습니다. HP는 만족스러운 고객 보증을 위해 공인 서비스 제공업체를 통해 부품을 교체하도록 하고 있습니다. 이러한 부품들은 Illustrated Parts Catalog에 "No"라고 표시되어 있습니다.

CSR 부품은 재고 상태와 지리적 조건이 허용하는 경우 다음 영업일 납품이 가능하도록 배송이 이루어집니다. 지리적 조건이 허용하는 경우 추가 비용이 청구되는 조건으로 당일 또는 4시간 배송이 가능할 수도 있습니다. 도움이 필요하시면 HP 기술 지원 센터로 전화하십시오. 전문 기술자가 전화로 도움을 줄 것입니다. HP는 결함이 발생한 부품을 HP로 반환해야 하는지 여부를 CSR 교체 부품과 함께 배송된 자료에 지정합니다. 결함이 발생한 부품을 HP로 반환해야 하는 경우에는 지정된 기간 내(통상 영업일 기준 5일)에 HP로 반환해야 합니다. 이 때 결함이 발생한 부품은 제공된 포장 재료에 넣어 관련 설명서와 함께 반환해야 합니다. 결함이 발생한 부품을 반환하지 않는 경우 HP가 교체 부품에 대해 비용을 청구할 수 있습니다. 고객 셀프 수리의 경우, HP는 모든 운송 및 부품 반환 비용을 부담하며 이용할 운송업체 및 택배 서비스를 결정합니다.

HP 고객 셀프 수리 프로그램에 대한 자세한 내용은 가까운 서비스 제공업체에 문의하십시오. 북미 지역의 프로그램에 대해서는 HP 웹 사이트(<http://www.hp.com/go/selfrepair>)를 참조하십시오.

---

# Acronyms and abbreviations

## ABEND

abnormal end

## ACU

Array Configuration Utility

## AMP

Advanced Memory Protection

## API

application program interface

## ASHRAE

American Society of Heating, Refrigerating and Air-Conditioning Engineers

## ASR

Automatic Server Recovery

## BP

backplane

## CAS

column address strobe

## CSA

Canadian Standards Association

## CSR

Customer Self Repair

## DDR3

double data rate-3

## DDR4

double data rate-4

## DPC

DIMMs per channel

## FAT

file allocation table

## FBWC

flash-backed write cache

## HBA

host bus adapter

## HP SIM

HP Systems Insight Manager

## HP SSA

HP Smart Storage Administrator

## HP SUM

HP Smart Update Manager

## IEC

International Electrotechnical Commission

## iLO

Integrated Lights-Out

## IML

Integrated Management Log

## ISO

International Organization for Standardization

## JSON

JavaScript Object Notation

## LFF

large form factor

## LOM

Lights-Out Management

## LRDIMM

load reduced dual in-line memory module

## NMI

nonmaskable interrupt

## NVRAM

nonvolatile memory

## OA

Onboard Administrator

## ODD

Optical Disk Drive

## PCIe

Peripheral Component Interconnect Express

## PDU

power distribution unit

## POST

Power-On Self Test

## PSU

power supply unit

## RDIMM

registered dual in-line memory module

## RDP

Rapid Deployment Pack

## REST

representational state transfer

## RoHS

Restriction of Hazardous Substances

## RPS

redundant power supply

## SAS

serial attached SCSI

## SATA

serial ATA

## SD

Secure Digital

## SFF

small form factor

## SIM

Systems Insight Manager

## SPP

HP Service Pack for ProLiant

## SSD

solid-state drive

## STD

standard (DIMM voltage)

## TMRA

recommended ambient operating temperature

## TPM

Trusted Platform Module

## UEFI

Unified Extensible Firmware Interface

## UID

unit identification

## USB

universal serial bus

## VC

Virtual Connect

VCA

Version Control Agent

VCRM

Version Control Repository Manager

xHCI

Extensible Host Controller Interface



---

# Documentation feedback

HP is committed to providing documentation that meets your needs. To help us improve the documentation, send any errors, suggestions, or comments to Documentation Feedback (<mailto:docsfeedback@hp.com>). Include the document title and part number, version number, or the URL when submitting your feedback.

---

# Index

## A

- access panel, install 20
- Active Health System 85, 86
- ACU (Array Configuration Utility) 94
- Advanced ECC memory 56, 57
- Advanced ECC population guidelines 57
- Advanced ECC support 56
- airflow requirements 26, 27
- ambient temperature 27, 106
- authorized reseller 105, 108
- authorized technician 108
- Automatic Server Recovery (ASR) 94

## B

- battery packs, installing 46
- Belarus Kazakhstan Russia marking 103
- bezel, installing 37
- BIOS upgrade 85
- boot options 91, 93

## C

- cable management 34
- cable management arm 30
- cabling 75
- cabling, drive 75
- cache module installation 44
- Care Pack 26, 88, 99, 108
- cautions 105
- central connect 88
- change control and proactive notification 99
- clearing NVRAM 13
- CMOS 13
- components, front panel 7
- components, rear panel 10
- configuration of system 85
- contacting HP 108
- crash dump analysis 14
- customer self repair (CSR) 108

## D

- default settings 56

- diagnosing problems 100
- diagnostic tools 85, 89, 93, 94
- dimensions and weight 106
- DIMM identification 55
- DIMM installation guidelines 54, 55
- DIMM slot locations 13
- DIMMs, installing 57
- DIMMs, single- dual-, and quad-rank 54
- direct connect 88
- documentation feedback 121
- drive cabling 41, 75
- drive LEDs 14
- drivers 97
- drives, installation guidelines 38
- drives, installing 38

## E

- electrical grounding requirements 28
- electrostatic discharge 105
- embedded UEFI diagnostics 93
- embedded UEFI shell 93
- enabling the Trusted Platform Module 73
- environmental requirements 26
- environmental specifications 106
- Erase Utility 85, 89
- error messages 100
- EuroAsian Economic Commission 103
- expansion board options 63
- extending server from rack 17
- external USB functionality 95

## F

- fan modules, installation 51
- FBWC cabling 75
- FBWC module 44
- firmware 95, 98
- flexible boot control 91
- Foundation Care Services 99
- front panel components 7

## G

- GPU power cabling 84
- grounding methods 105

grounding requirements 28, 105

## H

hardware options installation 37  
health driver 94  
help resources 108  
hot-swap fan 51  
HP Care Pack Services 26, 99  
HP Collaborative Support 99  
HP contact information 108  
HP Insight Diagnostics 89  
HP Insight Diagnostics survey functionality 89  
HP Insight Online 85, 88  
HP Insight Online direct connect 88  
HP Insight Remote Support software 88, 99  
HP Proactive Care 99  
HP RESTful API 87, 93  
HP Service Pack for ProLiant 85, 89, 90  
HP Smart Storage Battery 46  
HP Smart Update Manager overview 85, 90  
HP SmartMemory 53  
HP SSA (HP Smart Storage Administrator) 85, 94  
HP Support Center 99  
HP Systems Insight Manager (SIM) 87, 89  
HP technical support 99, 108  
HP Trusted Platform Module option 71  
HP website 108  
humidity 106

## I

identifying the server shipping carton contents 30  
Insight Diagnostics 89, 95  
Insight Online direct connect 88  
installation services 26, 30  
installing hardware 30, 37  
integrated array controller 41  
Integrated Lights-Out (iLO) 85, 87  
Integrated Management Log (IML) 87  
Intelligent Provisioning 85, 88, 89, 91

## L

LED, health 9  
LEDs, drive 14  
LEDs, NIC 10  
LEDs, power fault 9  
LEDs, power supply 9  
LEDs, rear panel 10  
legacy USB support 94

## M

maintenance guidelines 95  
mechanical specifications 106  
memory configurations 56  
memory dump 14  
memory options 53  
memory subsystem architecture 54  
memory, Advanced ECC 56  
memory, configuring 56  
memory, online spare 56  
Mini-SAS cabling 75

## N

NIC connectors 10  
NMI functionality 14  
NMI header 14  
non-hot-plug drives, installing 38  
notification actions 99

## O

online spare memory 56, 57  
online spare population guidelines 56, 57  
operating environment, recommended 26  
operating system crash 14, 94  
operating system installation 35, 99  
operating systems supported 89, 98, 99  
optimum environment 26  
options installation 30, 37

## P

PCI riser cage, installing 23  
PCI riser cage, removing 22  
power calculator 28, 107  
power distribution unit (PDU) 28  
power fault 9  
power requirements 28  
power supply LEDs 9  
powering down 17  
powering up 17, 34  
power-on password 13  
proactive notification 99  
problem diagnosis 100  
Product ID 93

## Q

QR code label 91  
QuickSpecs 41, 44, 55, 85

## R

- rack ears 30
- rack installation 26
- rack rail hook-and-loop strap 34
- rack warnings 29
- RAID configuration 94
- Rapid Deployment Pack (RDP) 26
- rear panel components 10
- rear panel LEDs 10
- recommended ambient operating temperature (TMRA) 27
- recovery key 73
- redundant fan 50
- redundant ROM 95
- re-entering the server serial number 93
- registering the server 36
- regulatory compliance information 103
- removing server from rack 18
- removing the security bezel 18
- requirements, airflow 26
- requirements, electrical grounding 28
- requirements, environmental 26, 106
- requirements, power 28
- requirements, site 27
- requirements, space 26
- requirements, temperature 27
- RoHS 104

## S

- safety considerations 95, 103, 105
- safety information 95, 103
- scripted installation 90
- scripting toolkit 85, 90
- secure boot configuration 92
- security bezel 37
- security bezel, removing 18
- serial number 93
- Server mode 85
- server options, installing 37
- server setup 26, 95
- server specifications 106
- server warnings and cautions 28, 29
- Service Packs 90
- shipping carton contents 30
- site requirements 27
- Smart Update Manager 85, 90
- space and airflow requirements 26
- specifications, environmental 106
- specifications, server 106

- SPP 89, 90
- static electricity 105
- storage controller 13, 44, 75
- supported operating systems 98, 99
- system configuration settings 13, 95
- System Erase Utility 89
- system maintenance switch 13
- system, keeping current 95

## T

- technical support 99, 108
- technology services 99
- temperature requirements 27, 106
- TMRA (recommended ambient operating temperature) 27
- troubleshooting resources 100
- Trusted Platform Module (TPM) 71, 73
- Turkey RoHS material content declaration 104

## U

- UEFI System Utilities 91
- Ukraine RoHS material content declaration 104
- uninterruptible power supply (UPS) 28
- updating the system ROM 95, 96, 97
- USB support 94
- utilities 85, 91, 94
- utilities, deployment 85, 90

## V

- ventilation 26
- Version Control Agent (VCA) 98
- Version Control Repository Manager (VCRM) 98
- video connector 10
- Virtualization option 99

## W

- warnings 28, 29
- warranty information 104
- website, HP 108
- weight 106

## Free Manuals Download Website

<http://myh66.com>

<http://usermanuals.us>

<http://www.somanuals.com>

<http://www.4manuals.cc>

<http://www.manual-lib.com>

<http://www.404manual.com>

<http://www.luxmanual.com>

<http://aubethermostatmanual.com>

Golf course search by state

<http://golfingnear.com>

Email search by domain

<http://emailbydomain.com>

Auto manuals search

<http://auto.somanuals.com>

TV manuals search

<http://tv.somanuals.com>