

HP ProLiant SL4540 Gen8 Server Node Maintenance and Service Guide

Abstract

This guide describes identification and maintenance procedures, diagnostic tools, specifications for hardware components and software for the HP ProLiant SL4540 Gen8 Server Node. This guide is for an experienced service technician. HP assumes you are qualified in the servicing of computer equipment, trained in recognizing hazards in products, and are familiar with weight and stability precautions.



Part Number: 683990-003
February 2014
Edition: 3

© Copyright 2012, 2014 Hewlett-Packard Development Company, L.P.

The information contained herein is subject to change without notice. The only warranties for HP products and services are set forth in the express warranty statements accompanying such products and services. Nothing herein should be construed as constituting an additional warranty. HP shall not be liable for technical or editorial errors or omissions contained herein.

Microsoft® and Windows® are U.S. registered trademarks of Microsoft Corporation.

Intel® and Xeon® are registered trademarks of Intel Corporation in the U.S. and other countries.

Contents

| | |
|--|----|
| Customer self repair | 5 |
| Parts only warranty service | 5 |
| Illustrated parts catalog | 15 |
| Mechanical components..... | 15 |
| System components | 17 |
| Removal and replacement procedures | 22 |
| Required tools..... | 22 |
| Preparation procedures | 22 |
| Power down the node | 22 |
| Remove a node from the chassis..... | 23 |
| Installing a node into the chassis | 23 |
| Remove the access panel..... | 24 |
| Install the access panel..... | 24 |
| Safety considerations..... | 24 |
| Preventing electrostatic discharge | 24 |
| Symbols on equipment | 25 |
| Server warnings and cautions | 25 |
| Drive blank..... | 26 |
| Drive | 26 |
| DIMMs..... | 28 |
| Heatsink..... | 29 |
| Processor | 30 |
| SFF backplane board..... | 35 |
| Front panel board | 36 |
| Personality board assembly | 37 |
| SUV interface board | 38 |
| System board | 39 |
| System battery | 47 |
| HP Trusted Platform Module | 47 |
| Troubleshooting | 49 |
| Troubleshooting resources | 49 |
| Diagnostic tools | 50 |
| HP ROM-Based Setup Utility | 50 |
| HP Insight Diagnostics..... | 50 |
| Integrated Management Log | 50 |
| HP Insight Remote Support software | 51 |
| Component identification..... | 52 |
| Front panel components | 52 |
| Front panel LEDs and buttons | 52 |
| Hot-plug drive LED definitions..... | 53 |
| System board components..... | 54 |
| DIMM slots | 55 |
| System maintenance switch..... | 55 |

| | |
|--|-----------|
| NMI jumper | 55 |
| Personality board components | 56 |
| Cabling | 57 |
| Personality board cabling | 57 |
| HDD data LED cabling | 57 |
| SATA cabling | 58 |
| Internal power cabling | 58 |
| RPS cabling | 59 |
| Front I/O cabling | 59 |
| SATA board power cabling | 60 |
| USB/VGA cabling | 60 |
| Specifications | 61 |
| Environmental specifications | 61 |
| Hot-plug power supply calculations | 61 |
| Acronyms and abbreviations | 62 |
| Documentation feedback | 63 |
| Index | 64 |

Customer self repair

HP products are designed with many Customer Self Repair (CSR) parts to minimize repair time and allow for greater flexibility in performing defective parts replacement. If during the diagnosis period HP (or HP service providers or service partners) identifies that the repair can be accomplished by the use of a CSR part, HP will ship that part directly to you for replacement. There are two categories of CSR parts:

- **Mandatory**—Parts for which customer self repair is mandatory. If you request HP to replace these parts, you will be charged for the travel and labor costs of this service.
- **Optional**—Parts for which customer self repair is optional. These parts are also designed for customer self repair. If, however, you require that HP replace them for you, there may or may not be additional charges, depending on the type of warranty service designated for your product.

NOTE: Some HP parts are not designed for customer self repair. In order to satisfy the customer warranty, HP requires that an authorized service provider replace the part. These parts are identified as "No" in the Illustrated Parts Catalog.

Based on availability and where geography permits, CSR parts will be shipped for next business day delivery. Same day or four-hour delivery may be offered at an additional charge where geography permits. If assistance is required, you can call the HP Technical Support Center and a technician will help you over the telephone. HP specifies in the materials shipped with a replacement CSR part whether a defective part must be returned to HP. In cases where it is required to return the defective part to HP, you must ship the defective part back to HP within a defined period of time, normally five (5) business days. The defective part must be returned with the associated documentation in the provided shipping material. Failure to return the defective part may result in HP billing you for the replacement. With a customer self repair, HP will pay all shipping and part return costs and determine the courier/carrier to be used.

For more information about HP's Customer Self Repair program, contact your local service provider. For the North American program, refer to the HP website (<http://www.hp.com/go/selfrepair>).

Parts only warranty service

Your HP Limited Warranty may include a parts only warranty service. Under the terms of parts only warranty service, HP will provide replacement parts free of charge.

For parts only warranty service, CSR part replacement is mandatory. If you request HP to replace these parts, you will be charged for the travel and labor costs of this service.

Réparation par le client (CSR)

Les produits HP comportent de nombreuses pièces CSR (Customer Self Repair = réparation par le client) afin de minimiser les délais de réparation et faciliter le remplacement des pièces défectueuses. Si pendant la période de diagnostic, HP (ou ses partenaires ou mainteneurs agréés) détermine que la réparation peut être effectuée à l'aide d'une pièce CSR, HP vous l'envoie directement. Il existe deux catégories de pièces CSR:

Obligatoire - Pièces pour lesquelles la réparation par le client est obligatoire. Si vous demandez à HP de remplacer ces pièces, les coûts de déplacement et main d'œuvre du service vous seront facturés.

Facultatif - Pièces pour lesquelles la réparation par le client est facultative. Ces pièces sont également conçues pour permettre au client d'effectuer lui-même la réparation. Toutefois, si vous demandez à HP de remplacer ces pièces, l'intervention peut ou non vous être facturée, selon le type de garantie applicable à votre produit.

REMARQUE: Certaines pièces HP ne sont pas conçues pour permettre au client d'effectuer lui-même la réparation. Pour que la garantie puisse s'appliquer, HP exige que le remplacement de la pièce soit effectué par un Mainteneur Agréé. Ces pièces sont identifiées par la mention "Non" dans le Catalogue illustré.

Les pièces CSR sont livrées le jour ouvré suivant, dans la limite des stocks disponibles et selon votre situation géographique. Si votre situation géographique le permet et que vous demandez une livraison le jour même ou dans les 4 heures, celle-ci vous sera facturée. Pour bénéficier d'une assistance téléphonique, appelez le Centre d'assistance technique HP. Dans les documents envoyés avec la pièce de rechange CSR, HP précise s'il est nécessaire de lui retourner la pièce défectueuse. Si c'est le cas, vous devez le faire dans le délai indiqué, généralement cinq (5) jours ouvrés. La pièce et sa documentation doivent être retournées dans l'emballage fourni. Si vous ne retournez pas la pièce défectueuse, HP se réserve le droit de vous facturer les coûts de remplacement. Dans le cas d'une pièce CSR, HP supporte l'ensemble des frais d'expédition et de retour, et détermine la société de courses ou le transporteur à utiliser.

Pour plus d'informations sur le programme CSR de HP, contactez votre Mainteneur Agréé local. Pour plus d'informations sur ce programme en Amérique du Nord, consultez le site Web HP (<http://www.hp.com/go/selfrepair>).

Service de garantie "pièces seules"

Votre garantie limitée HP peut inclure un service de garantie "pièces seules". Dans ce cas, les pièces de rechange fournies par HP ne sont pas facturées.

Dans le cadre de ce service, la réparation des pièces CSR par le client est obligatoire. Si vous demandez à HP de remplacer ces pièces, les coûts de déplacement et main d'œuvre du service vous seront facturés.

Riparazione da parte del cliente

Per abbreviare i tempi di riparazione e garantire una maggiore flessibilità nella sostituzione di parti difettose, i prodotti HP sono realizzati con numerosi componenti che possono essere riparati direttamente dal cliente (CSR, Customer Self Repair). Se in fase di diagnostica HP (o un centro di servizi o di assistenza HP) identifica il guasto come riparabile mediante un ricambio CSR, HP lo spedisce direttamente al cliente per la sostituzione. Vi sono due categorie di parti CSR:

Obbligatorie – Parti che devono essere necessariamente riparate dal cliente. Se il cliente ne affida la riparazione ad HP, deve sostenere le spese di spedizione e di manodopera per il servizio.

Opzionali – Parti la cui riparazione da parte del cliente è facoltativa. Si tratta comunque di componenti progettati per questo scopo. Se tuttavia il cliente ne richiede la sostituzione ad HP, potrebbe dover sostenere spese aggiuntive a seconda del tipo di garanzia previsto per il prodotto.

NOTA: alcuni componenti HP non sono progettati per la riparazione da parte del cliente. Per rispettare la garanzia, HP richiede che queste parti siano sostituite da un centro di assistenza autorizzato. Tali parti sono identificate da un "No" nel Catalogo illustrato dei componenti.

In base alla disponibilità e alla località geografica, le parti CSR vengono spedite con consegna entro il giorno lavorativo seguente. La consegna nel giorno stesso o entro quattro ore è offerta con un supplemento di costo solo in alcune zone. In caso di necessità si può richiedere l'assistenza telefonica di un addetto del centro di supporto tecnico HP. Nel materiale fornito con una parte di ricambio CSR, HP specifica se il cliente deve restituire dei componenti. Qualora sia richiesta la resa ad HP del componente difettoso, lo si deve spedire ad HP entro un determinato periodo di tempo, generalmente cinque (5) giorni lavorativi. Il componente difettoso deve essere restituito con la documentazione associata nell'imballo di spedizione fornito. La mancata restituzione del componente può comportare la fatturazione del ricambio da parte di HP. Nel caso di riparazione da parte del cliente, HP sostiene tutte le spese di spedizione e resa e sceglie il corriere/vettore da utilizzare.

Per ulteriori informazioni sul programma CSR di HP contattare il centro di assistenza di zona. Per il programma in Nord America fare riferimento al sito Web HP (<http://www.hp.com/go/selfrepair>).

Servizio di garanzia per i soli componenti

La garanzia limitata HP può includere un servizio di garanzia per i soli componenti. Nei termini di garanzia del servizio per i soli componenti, HP fornirà gratuitamente le parti di ricambio.

Per il servizio di garanzia per i soli componenti è obbligatoria la formula CSR che prevede la riparazione da parte del cliente. Se il cliente invece richiede la sostituzione ad HP, dovrà sostenere le spese di spedizione e di manodopera per il servizio.

Customer Self Repair

HP Produkte enthalten viele CSR-Teile (Customer Self Repair), um Reparaturzeiten zu minimieren und höhere Flexibilität beim Austausch defekter Bauteile zu ermöglichen. Wenn HP (oder ein HP Servicepartner) bei der Diagnose feststellt, dass das Produkt mithilfe eines CSR-Teils repariert werden kann, sendet Ihnen HP dieses Bauteil zum Austausch direkt zu. CSR-Teile werden in zwei Kategorien unterteilt:

Zwingend – Teile, für die das Customer Self Repair-Verfahren zwingend vorgegeben ist. Wenn Sie den Austausch dieser Teile von HP vornehmen lassen, werden Ihnen die Anfahrt- und Arbeitskosten für diesen Service berechnet.

Optional – Teile, für die das Customer Self Repair-Verfahren optional ist. Diese Teile sind auch für Customer Self Repair ausgelegt. Wenn Sie jedoch den Austausch dieser Teile von HP vornehmen lassen möchten, können bei diesem Service je nach den für Ihr Produkt vorgesehenen Garantiebedingungen zusätzliche Kosten anfallen.

HINWEIS: Einige Teile sind nicht für Customer Self Repair ausgelegt. Um den Garantieanspruch des Kunden zu erfüllen, muss das Teil von einem HP Servicepartner ersetzt werden. Im illustrierten Teilekatalog sind diese Teile mit „No“ bzw. „Nein“ gekennzeichnet.

CSR-Teile werden abhängig von der Verfügbarkeit und vom Lieferziel am folgenden Geschäftstag geliefert. Für bestimmte Standorte ist eine Lieferung am selben Tag oder innerhalb von vier Stunden gegen einen Aufpreis verfügbar. Wenn Sie Hilfe benötigen, können Sie das HP technische Support Center anrufen und sich von einem Mitarbeiter per Telefon helfen lassen. Den Materialien, die mit einem CSR-Ersatzteil geliefert werden, können Sie entnehmen, ob das defekte Teil an HP zurückgeschickt werden muss. Wenn es erforderlich ist, das defekte Teil an HP zurückzuschicken, müssen Sie dies innerhalb eines vorgegebenen Zeitraums tun, in der Regel innerhalb von fünf (5) Geschäftstagen. Das defekte Teil muss mit der zugehörigen Dokumentation in der Verpackung zurückgeschickt werden, die im Lieferumfang enthalten ist. Wenn Sie das

defekte Teil nicht zurückschicken, kann HP Ihnen das Ersatzteil in Rechnung stellen. Im Falle von Customer Self Repair kommt HP für alle Kosten für die Lieferung und Rücksendung auf und bestimmt den Kurier-/Frachtdienst.

Weitere Informationen über das HP Customer Self Repair Programm erhalten Sie von Ihrem Servicepartner vor Ort. Informationen über das CSR-Programm in Nordamerika finden Sie auf der HP Website unter (<http://www.hp.com/go/selfrepair>).

Parts-only Warranty Service (Garantieservice ausschließlich für Teile)

Ihre HP Garantie umfasst möglicherweise einen Parts-only Warranty Service (Garantieservice ausschließlich für Teile). Gemäß den Bestimmungen des Parts-only Warranty Service stellt HP Ersatzteile kostenlos zur Verfügung.

Für den Parts-only Warranty Service ist das CSR-Verfahren zwingend vorgegeben. Wenn Sie den Austausch dieser Teile von HP vornehmen lassen, werden Ihnen die Anfahrt- und Arbeitskosten für diesen Service berechnet.

Reparaciones del propio cliente

Los productos de HP incluyen muchos componentes que el propio usuario puede reemplazar (*Customer Self Repair*, CSR) para minimizar el tiempo de reparación y ofrecer una mayor flexibilidad a la hora de realizar sustituciones de componentes defectuosos. Si, durante la fase de diagnóstico, HP (o los proveedores o socios de servicio de HP) identifica que una reparación puede llevarse a cabo mediante el uso de un componente CSR, HP le enviará dicho componente directamente para que realice su sustitución. Los componentes CSR se clasifican en dos categorías:

- **Obligatorio:** componentes para los que la reparación por parte del usuario es obligatoria. Si solicita a HP que realice la sustitución de estos componentes, tendrá que hacerse cargo de los gastos de desplazamiento y de mano de obra de dicho servicio.
- **Opcional:** componentes para los que la reparación por parte del usuario es opcional. Estos componentes también están diseñados para que puedan ser reparados por el usuario. Sin embargo, si precisa que HP realice su sustitución, puede o no conllevar costes adicionales, dependiendo del tipo de servicio de garantía correspondiente al producto.

NOTA: Algunos componentes no están diseñados para que puedan ser reparados por el usuario. Para que el usuario haga valer su garantía, HP pone como condición que un proveedor de servicios autorizado realice la sustitución de estos componentes. Dichos componentes se identifican con la palabra "No" en el catálogo ilustrado de componentes.

Según la disponibilidad y la situación geográfica, los componentes CSR se enviarán para que lleguen a su destino al siguiente día laborable. Si la situación geográfica lo permite, se puede solicitar la entrega en el mismo día o en cuatro horas con un coste adicional. Si precisa asistencia técnica, puede llamar al Centro de asistencia técnica de HP y recibirá ayuda telefónica por parte de un técnico. Con el envío de materiales para la sustitución de componentes CSR, HP especificará si los componentes defectuosos deberán devolverse a HP. En aquellos casos en los que sea necesario devolver algún componente a HP, deberá hacerlo en el periodo de tiempo especificado, normalmente cinco días laborables. Los componentes defectuosos deberán devolverse con toda la documentación relacionada y con el embalaje de envío. Si no

enviara el componente defectuoso requerido, HP podrá cobrarle por el de sustitución. En el caso de todas sustituciones que lleve a cabo el cliente, HP se hará cargo de todos los gastos de envío y devolución de componentes y escogerá la empresa de transporte que se utilice para dicho servicio.

Para obtener más información acerca del programa de Reparaciones del propio cliente de HP, póngase en contacto con su proveedor de servicios local. Si está interesado en el programa para Norteamérica, visite la página web de HP siguiente (<http://www.hp.com/go/selfrepair>).

Servicio de garantía exclusivo de componentes

La garantía limitada de HP puede que incluya un servicio de garantía exclusivo de componentes. Según las condiciones de este servicio exclusivo de componentes, HP le facilitará los componentes de repuesto sin cargo adicional alguno.

Para este servicio de garantía exclusivo de componentes, es obligatoria la sustitución de componentes por parte del usuario (CSR). Si solicita a HP que realice la sustitución de estos componentes, tendrá que hacerse cargo de los gastos de desplazamiento y de mano de obra de dicho servicio.

Customer Self Repair

Veel onderdelen in HP producten zijn door de klant zelf te repareren, waardoor de reparatieduur tot een minimum beperkt kan blijven en de flexibiliteit in het vervangen van defecte onderdelen groter is. Deze onderdelen worden CSR-onderdelen (Customer Self Repair) genoemd. Als HP (of een HP Service Partner) bij de diagnose vaststelt dat de reparatie kan worden uitgevoerd met een CSR-onderdeel, verzendt HP dat onderdeel rechtstreeks naar u, zodat u het defecte onderdeel daarmee kunt vervangen. Er zijn twee categorieën CSR-onderdelen:

Verplicht: Onderdelen waarvoor reparatie door de klant verplicht is. Als u HP verzoekt deze onderdelen voor u te vervangen, worden u voor deze service reiskosten en arbeidsloon in rekening gebracht.

Optioneel: Onderdelen waarvoor reparatie door de klant optioneel is. Ook deze onderdelen zijn ontworpen voor reparatie door de klant. Als u echter HP verzoekt deze onderdelen voor u te vervangen, kunnen daarvoor extra kosten in rekening worden gebracht, afhankelijk van het type garantieservice voor het product.

OPMERKING: Sommige HP onderdelen zijn niet ontwikkeld voor reparatie door de klant. In verband met de garantievoorwaarden moet het onderdeel door een geautoriseerde Service Partner worden vervangen. Deze onderdelen worden in de geïllustreerde onderdelencatalogus aangemerkt met "Nee".

Afhankelijk van de leverbaarheid en de locatie worden CSR-onderdelen verzonden voor levering op de eerstvolgende werkdag. Levering op dezelfde dag of binnen vier uur kan tegen meerkosten worden aangeboden, indien dit mogelijk is gezien de locatie. Indien assistentie gewenst is, belt u een HP Service Partner om via de telefoon technische ondersteuning te ontvangen. HP vermeldt in de documentatie bij het vervangende CSR-onderdeel of het defecte onderdeel aan HP moet worden geretourneerd. Als het defecte onderdeel aan HP moet worden teruggezonden, moet u het defecte onderdeel binnen een bepaalde periode, gewoonlijk vijf (5) werkdagen, retourneren aan HP. Het defecte onderdeel moet met de bijbehorende documentatie worden geretourneerd in het meegeleverde verpakkingsmateriaal. Als u het defecte onderdeel niet terugzendt, kan HP u voor het vervangende onderdeel kosten in rekening brengen. Bij reparatie door de klant betaalt HP alle verzendkosten voor het vervangende en geretourneerde onderdeel en kiest HP zelf welke koerier/transportonderneming hiervoor wordt gebruikt.

Neem contact op met een Service Partner voor meer informatie over het Customer Self Repair programma van HP. Informatie over Service Partners vindt u op de HP website (<http://www.hp.com/go/selfrepair>).

Garantieservice "Parts Only"

Het is mogelijk dat de HP garantie alleen de garantieservice "Parts Only" omvat. Volgens de bepalingen van de Parts Only garantieservice zal HP kosteloos vervangende onderdelen ter beschikking stellen.

Voor de Parts Only garantieservice is vervanging door CSR-onderdelen verplicht. Als u HP verzoekt deze onderdelen voor u te vervangen, worden u voor deze service reiskosten en arbeidsloon in rekening gebracht.

Reparo feito pelo cliente

Os produtos da HP são projetados com muitas peças para reparo feito pelo cliente (CSR) de modo a minimizar o tempo de reparo e permitir maior flexibilidade na substituição de peças com defeito. Se, durante o período de diagnóstico, a HP (ou fornecedores/parceiros de serviço da HP) concluir que o reparo pode ser efetuado pelo uso de uma peça CSR, a peça de reposição será enviada diretamente ao cliente. Existem duas categorias de peças CSR:

Obrigatória – Peças cujo reparo feito pelo cliente é obrigatório. Se desejar que a HP substitua essas peças, serão cobradas as despesas de transporte e mão-de-obra do serviço.

Opcional – Peças cujo reparo feito pelo cliente é opcional. Essas peças também são projetadas para o reparo feito pelo cliente. No entanto, se desejar que a HP as substitua, pode haver ou não a cobrança de taxa adicional, dependendo do tipo de serviço de garantia destinado ao produto.

OBSERVAÇÃO: Algumas peças da HP não são projetadas para o reparo feito pelo cliente. A fim de cumprir a garantia do cliente, a HP exige que um técnico autorizado substitua a peça. Essas peças estão identificadas com a marca "No" (Não), no catálogo de peças ilustrado.

Conforme a disponibilidade e o local geográfico, as peças CSR serão enviadas no primeiro dia útil após o pedido. Onde as condições geográficas permitirem, a entrega no mesmo dia ou em quatro horas pode ser feita mediante uma taxa adicional. Se precisar de auxílio, entre em contato com o Centro de suporte técnico da HP para que um técnico o ajude por telefone. A HP especifica nos materiais fornecidos com a peça CSR de reposição se a peça com defeito deve ser devolvida à HP. Nos casos em que isso for necessário, é preciso enviar a peça com defeito à HP dentro do período determinado, normalmente cinco (5) dias úteis. A peça com defeito deve ser enviada com a documentação correspondente no material de transporte fornecido. Caso não o faça, a HP poderá cobrar a reposição. Para as peças de reparo feito pelo cliente, a HP paga todas as despesas de transporte e de devolução da peça e determina a transportadora/serviço postal a ser utilizado.

Para obter mais informações sobre o programa de reparo feito pelo cliente da HP, entre em contato com o fornecedor de serviços local. Para o programa norte-americano, visite o site da HP (<http://www.hp.com/go/selfrepair>).

Serviço de garantia apenas para peças

A garantia limitada da HP pode incluir um serviço de garantia apenas para peças. Segundo os termos do serviço de garantia apenas para peças, a HP fornece as peças de reposição sem cobrar nenhuma taxa.

No caso desse serviço, a substituição de peças CSR é obrigatória. Se desejar que a HP substitua essas peças, serão cobradas as despesas de transporte e mão-de-obra do serviço.

カスタマーセルフリペア

修理時間を短縮し、故障部品の交換における高い柔軟性を確保するために、HP製品には多数のCSR部品があります。診断の際に、CSR部品を使用すれば修理ができるとHP（HPまたはHP正規保守代理店）が判断した場合、HPはその部品を直接、お客様に発送し、お客様に交換していただきます。CSR部品には以下の2通りがあります。

- **必須** - カスタマーセルフリペアが必須の部品。当該部品について、もしもお客様がHPに交換作業を依頼される場合には、その修理サービスに関する交通費および人件費がお客様に請求されます。
- **任意** - カスタマーセルフリペアが任意である部品。この部品もカスタマーセルフリペア用です。当該部品について、もしもお客様がHPに交換作業を依頼される場合には、お買い上げの製品に適用される保証サービス内容の範囲内においては、別途費用を負担していただくことなく保証サービスを受けることができます。

注： HP製品の一部の部品は、カスタマーセルフリペア用ではありません。製品の保証を継続するためには、HPまたはHP正規保守代理店による交換作業が必須となります。部品カタログには、当該部品がカスタマーセルフリペア除外品である旨が記載されています。

部品供給が可能な場合、地域によっては、CSR部品を翌営業日に届くように発送します。また、地域によっては、追加費用を負担いただくことにより同日または4時間以内に届くように発送することも可能な場合があります。サポートが必要なときは、HPの修理受付窓口へ電話していただければ、技術者が電話でアドバイスします。交換用のCSR部品または同梱物には、故障部品をHPに返送する必要があるかどうかが表示されています。故障部品をHPに返送する必要がある場合は、指定期限内（通常は5営業日以内）に故障部品をHPに返送してください。故障部品を返送する場合は、届いた時の梱包箱に関連書類とともに入れてください。故障部品を返送しない場合、HPから部品費用が請求されます。カスタマーセルフリペアの際には、HPは送料および部品返送費を全額負担し、使用する宅配便会社や運送会社を指定します。

部品のみ保証サービス

HP保証サービスには、部品のみ保証サービスが適用される場合があります。このサービスでは、交換部品は無償で提供されます。

部品のみ保証サービスにおいては、CSR部品をお客様により交換作業していただくことが必須となります。当該部品について、もしもお客様がHPに交換作業を依頼される場合には、その修理サービスに関する交通費および人件費はお客様の負担となります。

客户自行维修

HP 产品提供许多客户自行维修 (CSR) 部件，以尽可能缩短维修时间和在更换缺陷部件方面提供更大的灵活性。如果在诊断期间 HP（或 HP 服务提供商或服务合作伙伴）确定可以通过使用 CSR 部件完成维修，HP 将直接把该部件发送给您进行更换。有两类 CSR 部件：

- **强制性的** — 要求客户必须自行维修的部件。如果您请求 HP 更换这些部件，则必须为该服务支付差旅费和人工费用。
- **可选的** — 客户可以选择是否自行维修的部件。这些部件也是为客户自行维修设计的。不过，如果您要求 HP 为您更换这些部件，则根据为您的产品指定的保修服务类型，HP 可能收取或不再收取任何附加费用。

注：某些 HP 部件的设计并未考虑客户自行维修。为了满足客户保修的需要，HP 要求授权服务提供商更换相关部件。这些部件在部件图解目录中标记为“否”。

CSR 部件将在下一个工作日发运（取决于备货情况和允许的地理范围）。在允许的地理范围内，可在当天或四小时内发运，但要收取额外费用。如果需要帮助，您可以致电 HP 技术支持中心，将会有技术人员通过电话为您提供帮助。HP 会在随更换的 CSR 部件发运的材料中指明是否必须将有缺陷的部件返还给 HP。如果要求您将有缺陷的部件返还给 HP，那么您必须在规定期限内（通常是五 (5) 个工作日）将缺陷部件发给 HP。有缺陷的部件必须随所提供的发运材料中的相关文件一起返还。如果未能送还缺陷的部件，HP 可能会要求您支付更换费用。客户自行维修时，HP 将承担所有相关运输和部件返回费用，并指定快递商/承运商。

有关 HP 客户自行维修计划的详细信息，请与您当地的服务提供商联系。有关北美地区的计划，请访问 HP 网站 (<http://www.hp.com/go/selfrepair>)。

仅部件保修服务

您的 HP 有限保修服务可能涉及仅部件保修服务。根据仅部件保修服务条款的规定，HP 将免费提供更换的部件。

仅部件保修服务要求进行 CSR 部件更换。如果您请求 HP 更换这些部件，则必须为该服务支付差旅费和人工费用。

客戶自行維修

HP 產品設計了許多「客戶自行維修」(CSR) 的零件以減少維修時間，並且使得更換瑕疵零件時能有更大的彈性。如果在診斷期間 HP (或 HP 服務供應商或維修夥伴) 辨認出此項維修工作可以藉由使用 CSR 零件來完成，則 HP 將直接寄送該零件給您作更換。CSR 零件分為兩種類別：

- **強制的** — 客戶自行維修所使用的零件是強制性的。如果您要求 HP 更換這些零件，HP 將會向您收取此服務所需的外出費用與勞動成本。
- **選購的** — 客戶自行維修所使用的零件是選購的。這些零件也設計用於客戶自行維修之用。不過，如果您要求 HP 為您更換，則可能需要也可能不需要負擔額外的費用，端視針對此產品指定的保固服務類型而定。

備註：某些 HP 零件沒有消費者可自行維修的設計。為符合客戶保固，HP 需要授權的服務供應商更換零件。這些零件在圖示的零件目錄中，被標示為「否」。

基於材料取得及環境允許的情況下，CSR 零件將於下一個工作日以快遞寄送。在環境的允許下當天或四小時內送達，則可能需要額外的費用。若您需要協助，可致電「HP 技術支援中心」，會有一位技術人員透過電話來協助您。不論損壞的零件是否必須退回，HP 皆會在與 CSR 替換零件一起運送的材料中註明。若要將損壞的零件退回 HP，您必須在指定的一段時間內（通常為五 (5) 個工作天），將損壞的零件寄回 HP。損壞的零件必須與寄送資料中隨附的相關技術文件一併退還。如果無法退還損壞的零件，HP 可能要向您收取替換費用。針對客戶自行維修情形，HP 將負責所有運費及零件退還費用並指定使用何家快遞/貨運公司。

如需 HP 的「客戶自行維修」方案詳細資訊，請連絡您當地的服務供應商。至於北美方案，請參閱 HP 網站 (<http://www.hp.com/go/selfrepair>)。

僅限零件的保固服務

您的「HP 有限保固」可能包含僅限零件的保固服務。在僅限零件的保固服務情況下，HP 將免費提供替換零件。

針對僅限零件的保固服務，CSR 零件替換是強制性的。如果您要求 HP 更換這些零件，HP 將會向您收取此服務所需的外出費用與勞動成本。

고객 셀프 수리

HP 제품은 수리 시간을 최소화하고 결함이 있는 부품 교체 시 더욱 용통성을 발휘할 수 있도록 하기 위해 고객 셀프 수리(CSR) 부품을 다량 사용하여 설계되었습니다. 진단 기간 동안 HP(또는 HP 서비스 공급업체 또는 서비스 협력업체)에서 CSR 부품을 사용하여 수리가 가능하다고 판단되면 HP는 해당 부품을 바로 사용자에게 보내어 사용자가 교체할 수 있도록 합니다. CSR 부품에는 두 가지 종류가 있습니다.

- **고객 셀프 수리가 의무 사항인 필수 부품.** 사용자가 HP에 이 부품의 교체를 요청할 경우 이 서비스에 대한 출장비 및 작업비가 청구됩니다.
- **고객 셀프 수리가 선택 사항인 부품.** 이 부품들도 고객 셀프 수리가 가능하도록 설계되었습니다. 하지만 사용자가 HP에 이 부품의 교체를 요청할 경우 사용자가 구입한 제품에 해당하는 보증 서비스 유형에 따라 추가 비용 없이 교체가 가능할 수 있습니다.

참고: 일부 HP 부품은 고객 셀프 수리가 불가능하도록 설계되었습니다. HP는 만족스러운 고객 보증을 위해 공인 서비스 제공업체를 통해 부품을 교체하도록 하고 있습니다. 이러한 부품들은 Illustrated Parts Catalog에 "No"라고 표시되어 있습니다.

CSR 부품은 재고 상태와 지리적 조건이 허용하는 경우 다음 영업일 납품이 가능하도록 배송이 이루어집니다. 지리적 조건이 허용하는 경우 추가 비용이 청구되는 조건으로 당일 또는 4시간 배송이 가능할 수도 있습니다. 도움이 필요하시면 HP 기술 지원 센터로 전화하십시오. 전문 기술자가 전화로 도움을 줄 것입니다. HP는 결함이 발생한 부품을 HP로 반환해야 하는지 여부를 CSR 교체 부품과 함께 배송된 자료에 지정합니다. 결함이 발생한 부품을 HP로 반환해야 하는 경우에는 지정된 기간 내(통상 영업일 기준 5일)에 HP로 반환해야 합니다. 이 때 결함이 발생한 부품은 제공된 포장 재료에 넣어 관련 설명서와 함께 반환해야 합니다. 결함이 발생한 부품을 반환하지 않는 경우 HP가 교체 부품에 대해 비용을 청구할 수 있습니다. 고객 셀프 수리의 경우, HP는 모든 운송 및 부품 반환 비용을 부담하며 이용할 운송업체 및 택배 서비스를 결정합니다.

HP 고객 셀프 수리 프로그램에 대한 자세한 내용은 가까운 서비스 제공업체에 문의하십시오. 북미 지역의 프로그램에 대해서는 HP 웹 사이트(<http://www.hp.com/go/selfrepair>)를 참조하십시오.

부품 제공 보증 서비스

HP 제한 보증에는 부품 제공 보증 서비스가 포함될 수 있습니다. 이러한 경우 HP는 부품 제공 보증 서비스의 조건에 따라 교체 부품만을 무료로 제공합니다.

부품 제공 보증 서비스 제공 시 CSR 부품 교체는 의무 사항입니다. 사용자가 HP에 이 부품의 교체를 요청할 경우 이 서비스에 대한 출장비 및 작업비가 청구됩니다.

Illustrated parts catalog

Mechanical components

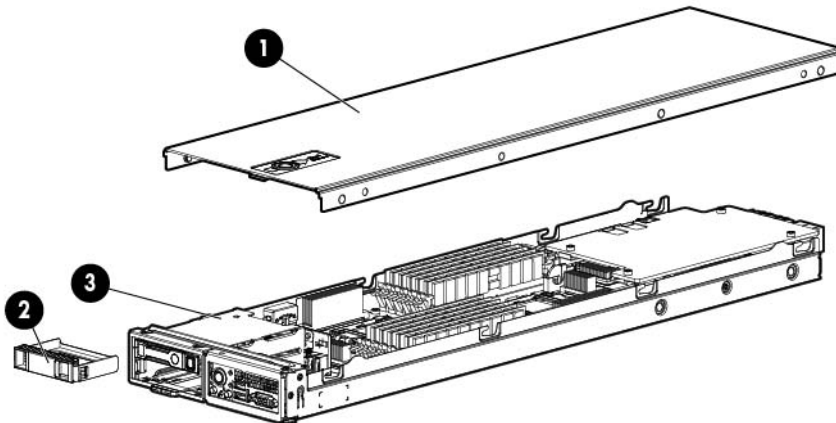

| Item | Description | Spare part number | Customer self repair (on page 5) |
|------|-------------------------|-------------------|----------------------------------|
| 1 | Access panel | 691280-001 | Mandatory ¹ |
| 2 | Drive blank, SFF | 670033-001 | Mandatory ¹ |
| 3 | HP ProLiant SL4540 node | — | — |

¹Mandatory—Parts for which customer self repair is mandatory. If you request HP to replace these parts, you will be charged for the travel and labor costs of this service.

²Optional—Parts for which customer self repair is optional. These parts are also designed for customer self repair. If, however, you require that HP replace them for you, there may or may not be additional charges, depending on the type of warranty service designated for your product.

³No—Some HP parts are not designed for customer self repair. In order to satisfy the customer warranty, HP requires that an authorized service provider replace the part. These parts are identified as "No" in the Illustrated Parts Catalog.

¹Mandatory: Obligatoire—Pièces pour lesquelles la réparation par le client est obligatoire. Si vous demandez à HP de remplacer ces pièces, les coûts de déplacement et main d'œuvre du service vous seront facturés.

²Optional: Facultatif—Pièces pour lesquelles la réparation par le client est facultative. Ces pièces sont également conçues pour permettre au client d'effectuer lui-même la réparation. Toutefois, si vous demandez à HP de remplacer ces pièces, l'intervention peut ou non vous être facturée, selon le type de garantie applicable à votre produit.

³No: Non—Certaines pièces HP ne sont pas conçues pour permettre au client d'effectuer lui-même la réparation. Pour que la garantie puisse s'appliquer, HP exige que le remplacement de la pièce soit effectué par un Mainteneur Agréé. Ces pièces sont identifiées par la mention "Non" dans le Catalogue illustré.

¹Mandatory: Obbligatorie—Parti che devono essere necessariamente riparate dal cliente. Se il cliente ne affida la riparazione ad HP, deve sostenere le spese di spedizione e di manodopera per il servizio.

²Optional: Opzionali—Parti la cui riparazione da parte del cliente è facoltativa. Si tratta comunque di componenti progettati per questo scopo. Se tuttavia il cliente ne richiede la sostituzione ad HP, potrebbe dover sostenere spese aggiuntive a seconda del tipo di garanzia previsto per il prodotto.

³No: Non CSR—Alcuni componenti HP non sono progettati per la riparazione da parte del cliente. Per rispettare la garanzia, HP richiede che queste parti siano sostituite da un centro di assistenza autorizzato. Tali parti sono identificate da un "No" nel Catalogo illustrato dei componenti.

¹Mandatory: Zwingend—Teile, die im Rahmen des Customer Self Repair Programms ersetzt werden müssen. Wenn Sie diese Teile von HP ersetzen lassen, werden Ihnen die Versand- und Arbeitskosten für diesen Service berechnet.

²Optional: Optional—Teile, für die das Customer Self Repair-Verfahren optional ist. Diese Teile sind auch für Customer Self Repair ausgelegt. Wenn Sie jedoch den Austausch dieser Teile von HP vornehmen lassen möchten, können bei diesem Service je nach den für Ihr Produkt vorgesehenen Garantiebedingungen zusätzliche Kosten anfallen.

³No: Kein—Einige Teile sind nicht für Customer Self Repair ausgelegt. Um den Garantieanspruch des Kunden zu erfüllen, muss das Teil von einem HP Servicepartner ersetzt werden. Im illustrierten Teilekatalog sind diese Teile mit „No“ bzw. „Nein“ gekennzeichnet.

¹Mandatory: Obligatorio—componentes para los que la reparación por parte del usuario es obligatoria. Si solicita a HP que realice la sustitución de estos componentes, tendrá que hacerse cargo de los gastos de desplazamiento y de mano de obra de dicho servicio.

²Optional: Opcional— componentes para los que la reparación por parte del usuario es opcional. Estos componentes también están diseñados para que puedan ser reparados por el usuario. Sin embargo, si precisa que HP realice su sustitución, puede o no conllevar costes adicionales, dependiendo del tipo de servicio de garantía correspondiente al producto.

³No: No—Algunos componentes no están diseñados para que puedan ser reparados por el usuario. Para que el usuario haga valer su garantía, HP pone como condición que un proveedor de servicios autorizado realice la sustitución de estos componentes. Dichos componentes se identifican con la palabra “No” en el catálogo ilustrado de componentes.

¹Mandatory: Verplicht—Onderdelen waarvoor Customer Self Repair verplicht is. Als u HP verzoekt deze onderdelen te vervangen, komen de reiskosten en het arbeidsloon voor uw rekening.

²Optional: Optioneel—Onderdelen waarvoor reparatie door de klant optioneel is. Ook deze onderdelen zijn ontworpen voor reparatie door de klant. Als u echter HP verzoekt deze onderdelen voor u te vervangen, kunnen daarvoor extra kosten in rekening worden gebracht, afhankelijk van het type garantieservice voor het product.

³No: Nee—Sommige HP onderdelen zijn niet ontwikkeld voor reparatie door de klant. In verband met de garantievooraarden moet het onderdeel door een geautoriseerde Service Partner worden vervangen. Deze onderdelen worden in de geïllustreerde onderdelencatalogus aangemerkt met "Nee".

¹Mandatory: Obrigatória—Peças cujo reparo feito pelo cliente é obrigatório. Se desejar que a HP substitua essas peças, serão cobradas as despesas de transporte e mão-de-obra do serviço.

²Optional: Opcional—Peças cujo reparo feito pelo cliente é opcional. Essas peças também são projetadas para o reparo feito pelo cliente. No entanto, se desejar que a HP as substitua, pode haver ou não a cobrança de taxa adicional, dependendo do tipo de serviço de garantia destinado ao produto.

³No: Nenhuma—Algumas peças da HP não são projetadas para o reparo feito pelo cliente. A fim de cumprir a garantia do cliente, a HP exige que um técnico autorizado substitua a peça. Essas peças estão identificadas com a marca “No” (Não), no catálogo de peças ilustrado.

¹Mandatory : 必須 - 顧客自己修理が必須の部品。当該部品について、もしもお客様がHPに交換作業を依頼される場合には、その修理サービスに関する交通費および人件費がお客様に請求されます。

²Optional : 任意 - 顧客自己修理が任意である部品。この部品も顧客自己修理用です。当該部品について、もしもお客様がHPに交換作業を依頼される場合には、お買い上げの製品に適用される保証サービス内容の範囲内においては、費用を負担していただくことなく保証サービスを受けることができます。

³No : 除外 - HP製品の一部の部品は、顧客自己修理用ではありません。製品の保証を継続するためには、HPまたはHP正規保守代理店による交換作業が必須となります。部品カタログには、当該部品が顧客自己修理除外品である旨が記載されています。

¹Mandatory: 强制性的 — 要求客户必须自行维修的部件。如果您请求 HP 更换这些部件，则必须为该服务支付差旅费和人工费用。

²Optional: 可选的 — 客户可以选择是否自行维修的部件。这些部件也是为客户自行维修设计的。不过，如果您要求 HP 为您更换这些部件，则根据您的产品指定的保修服务类型，HP 可能收取或不再收取任何附加费用。

³No: 否 — 某些 HP 部件的设计并未考虑客户自行维修。为了满足客户保修的需要，HP 要求授权服务提供商更换相关部件。这些部件在部件图解目录中标记为“否”。

¹Mandatory: 強制的 — 客戶自行維修所使用的零件是強制性的。如果您要求 HP 更換這些零件，HP 將會向您收取此服務所需的外出費用與勞動成本。

²Optional: 選購的 — 客戶自行維修所使用的零件是選購的。這些零件也設計用於客戶自行維修之用。不過，如果您要求 HP 為您更換，則可能需要也可能不需要負擔額外的費用，端視針對此產品指定的保固服務類型而定。

³No: 否 — 某些 HP 零件沒有消費者可自行維修的設計。為符合客戶保固，HP 需要授權的服務供應商更換零件。這些零件在圖示的零件目錄中，被標示為「否」。

¹ Mandatory: 필수 — 고객 셀프 수리가 의무 사항인 필수 부품. 사용자가 HP에 이 부품의 교체를 요청할 경우 이 서비스에 대한 출장비 및 작업비가 청구됩니다.

² Optional: 옵션 — 고객 셀프 수리가 선택 사항인 부품. 이 부품들도 고객 셀프 수리가 가능하도록 설계되었습니다. 하지만 사용자가 HP에 이 부품의 교체를 요청할 경우 사용자가 구입한 제품에 해당하는 보증 서비스 유형에 따라 추가 비용 없이 교체가 가능할 수 있습니다.

³ No: No — 고객 셀프 수리가 불가능하도록 설계된 HP 부품. 이 부품들은 고객 셀프 수리가 불가능하도록 설계되었습니다. HP는 고객 보증을 만족시키기 위해 공인 서비스 제공업체를 통해 부품을 교체하도록 하고 있습니다.

System components

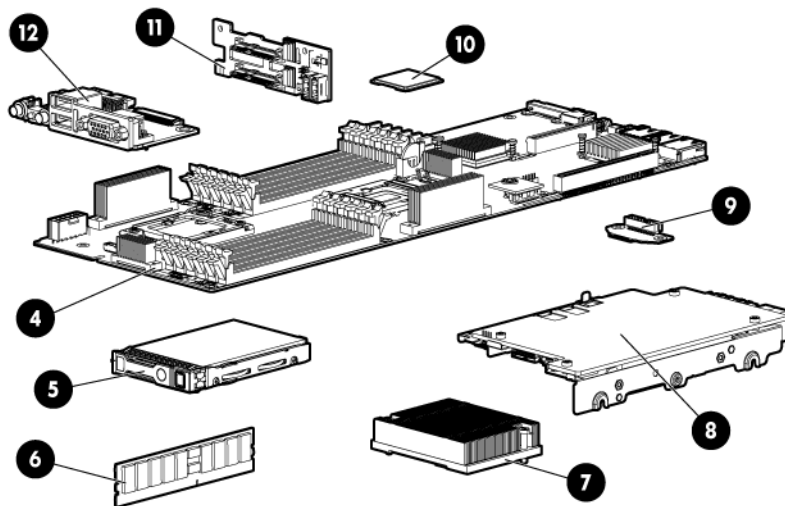

| Item | Description | Spare part number | Customer self repair (on page 5) |
|------|---|-------------------|----------------------------------|
| 4 | System boards | — | — |
| | a) System board | 687246-001 | Optional ² |
| | b) System board-IVB* | 755313-001 | Optional ² |
| 5 | Hot-plug solid state SATA drives | — | — |
| | a) 100-GB, SFF, MLC, 3G | 653965-001 | Mandatory ¹ |
| | b) 200-GB, SFF, MLC, 3G* | 653966-001 | Mandatory ¹ |
| | c) 400-GB, SFF, MLC, 3G* | 653967-001 | Mandatory ¹ |
| | d) 500-GB, SFF, MDL, 6G* | 656107-001 | Mandatory ¹ |
| | e) 1-TB, SFF, MDL, 6G* | 656108-001 | Mandatory ¹ |
| | Memory | | |
| 6 | DIMMs | — | — |
| | a) 4-GB, PC3L-10600R-9, single-rank x4 | 664688-001 | Mandatory ¹ |
| | b) 8-GB, PC3L-10600R-9, dual-rank x4* | 664690-001 | Mandatory ¹ |
| | c) 16-GB, PC3L-10600R-9, dual-rank x4* | 664692-001 | Mandatory ¹ |
| | d) 8-GB, PC3L-12800R, single-rank x4* † | 735302-001 | Mandatory ¹ |
| | e) 16-GB, PCL3-12800R, IPL 1Gx4* † | 715284-001 | Mandatory ¹ |
| | f) 8-GB, PCL3-12800R, IPL 512Mx4* † | 715283-001 | Mandatory ¹ |
| | g) 4-GB, PCL3-12800R, IPL 512Mx4* † | 715282-001 | Mandatory ¹ |
| | h) 8-GB, PCL3-12800E, IPL 512Mx8* † | 715281-001 | Mandatory ¹ |
| | i) 2-GB, PCL3-12800E, IPL 256Mx8* † | 715279-001 | Mandatory ¹ |
| | j) 4-GB, PCL3-12800E, IPL 256Mx8* † | 715208-001 | Mandatory ¹ |
| 7 | Heatsink | 689496-001 | Optional ² |
| 8 | Personality board assembly | 717703-001 | Optional ² |
| 9 | SUV interface board | 689237-001 | Mandatory ¹ |
| 10 | Processors | — | — |
| | a) 2.3-GHz Intel Xeon E5-2470 processor** | 676943-001 | Optional ² |
| | b) 2.4GHz Intel Xeon E5-2440 processor* ** | 676945-001 | Optional ² |
| | c) 2.2-GHz Intel Xeon E5-2430 processor* ** | 676946-001 | Optional ² |
| | d) 2.2 GHz Intel Xeon E5-2407 processor* ** | 676948-001 | Optional ² |
| | e) 2.0 GHz Intel Xeon E5-2430L processor* ** | 676950-001 | Optional ² |
| | f) 2.4-GHz Intel Xeon E5-2470v2 processor* ** † | 729115-001 | Optional ² |
| | g) 2.50-GHz Intel Xeon E5-2450 v2 processor* ** † | 729114-001 | Optional ² |
| | h) 1.90-GHz Intel Xeon E5-2440 v2 processor* ** † | 729113-001 | Optional ² |
| | i) 2.50-GHz Intel Xeon E5-2430 v2 processor* ** † | 729112-001 | Optional ² |
| | j) 2.20-GHz Intel Xeon E5-2420 v2 processor* ** † | 729111-001 | Optional ² |

| Item | Description | Spare part number | Customer self repair (on page 5) |
|------|--|-------------------|----------------------------------|
| | k) 2.40-GHz Intel Xeon E5-2407 v2 processor* ** † | 729110-001 | Optional ² |
| | l) 1.70-GHz Intel Xeon E5-2450L v2 processor* ** † | 729108-001 | Optional ² |
| | m) 2.40-GHz Intel Xeon E5-2430L v2 processor* ** † | 729107-001 | Optional ² |
| 11 | SFF drive backplane board | 689231-001 | Mandatory ¹ |
| 12 | Front panel board | 689232-001 | Mandatory ¹ |
| | Cables | — | — |
| 13 | USB/VGA cable* | 694549-001 | Optional ² |
| 14 | RJ-45 personality board assembly cable* | 694548-001 | Mandatory ¹ |
| 15 | RPS cable* | 694547-001 | Mandatory ¹ |
| 16 | Internal node power (RPS, PWR, MSAR, RT) cable* | 694539-001 | Mandatory ¹ |
| 17 | HDD data LED (SFF I2C) cable* | 694546-001 | Optional ² |
| 18 | Front LED cable* | 694545-001 | Optional ² |
| 19 | SATA power converter cable* | 694543-001 | Mandatory ¹ |
| 20 | SATA power/data cable* | 694540-001 | Optional ² |

* Not Shown

**All processors in this HP ProLiant node must have the same cache size, speed, number of cores, and rated maximum power consumption.

† For use only with system board 755313-001.

¹Mandatory—Parts for which customer self repair is mandatory. If you request HP to replace these parts, you will be charged for the travel and labor costs of this service.

²Optional—Parts for which customer self repair is optional. These parts are also designed for customer self repair. If, however, you require that HP replace them for you, there may or may not be additional charges, depending on the type of warranty service designated for your product.

³No—Some HP parts are not designed for customer self repair. In order to satisfy the customer warranty, HP requires that an authorized service provider replace the part. These parts are identified as "No" in the Illustrated Parts Catalog.

¹Mandatory: Obligatoire—Pièces pour lesquelles la réparation par le client est obligatoire. Si vous demandez à HP de remplacer ces pièces, les coûts de déplacement et main d'œuvre du service vous seront facturés.

²Optional: Facultatif—Pièces pour lesquelles la réparation par le client est facultative. Ces pièces sont également conçues pour permettre au client d'effectuer lui-même la réparation. Toutefois, si vous demandez à HP de remplacer ces pièces, l'intervention peut ou non vous être facturée, selon le type de garantie applicable à votre produit.

³No: Non—Certaines pièces HP ne sont pas conçues pour permettre au client d'effectuer lui-même la réparation. Pour que la garantie puisse s'appliquer, HP exige que le remplacement de la pièce soit effectué par un Mainteneur Agréé. Ces pièces sont identifiées par la mention "Non" dans le Catalogue illustré.

¹Mandatory: Obbligatorie—Parti che devono essere necessariamente riparate dal cliente. Se il cliente ne affida la riparazione ad HP, deve sostenere le spese di spedizione e di manodopera per il servizio.

²Optional: Opzionali—Parti la cui riparazione da parte del cliente è facoltativa. Si tratta comunque di componenti progettati per questo scopo. Se tuttavia il cliente ne richiede la sostituzione ad HP, potrebbe dover sostenere spese addizionali a seconda del tipo di garanzia previsto per il prodotto.

³No: Non CSR—Alcuni componenti HP non sono progettati per la riparazione da parte del cliente. Per rispettare la garanzia, HP richiede che queste parti siano sostituite da un centro di assistenza autorizzato. Tali parti sono identificate da un "No" nel Catalogo illustrato dei componenti.

¹Mandatory: Zwingend—Teile, die im Rahmen des Customer Self Repair Programms ersetzt werden müssen. Wenn Sie diese Teile von HP ersetzen lassen, werden Ihnen die Versand- und Arbeitskosten für diesen Service berechnet.

²Optional: Optional—Teile, für die das Customer Self Repair-Verfahren optional ist. Diese Teile sind auch für Customer Self Repair ausgelegt. Wenn Sie jedoch den Austausch dieser Teile von HP vornehmen lassen möchten, können bei diesem Service je nach den für Ihr Produkt vorgesehenen Garantiebedingungen zusätzliche Kosten anfallen.

³No: Kein—Einige Teile sind nicht für Customer Self Repair ausgelegt. Um den Garantieanspruch des Kunden zu erfüllen, muss das Teil von einem HP Servicepartner ersetzt werden. Im illustrierten Teilekatalog sind diese Teile mit „No“ bzw. „Nein“ gekennzeichnet.

¹Mandatory: Obligatorio—componentes para los que la reparación por parte del usuario es obligatoria. Si solicita a HP que realice la sustitución de estos componentes, tendrá que hacerse cargo de los gastos de desplazamiento y de mano de obra de dicho servicio.

²Optional: Opcional— componentes para los que la reparación por parte del usuario es opcional. Estos componentes también están diseñados para que puedan ser reparados por el usuario. Sin embargo, si precisa que HP realice su sustitución, puede o no conllevar costes adicionales, dependiendo del tipo de servicio de garantía correspondiente al producto.

³No: No—Algunos componentes no están diseñados para que puedan ser reparados por el usuario. Para que el usuario haga valer su garantía, HP pone como condición que un proveedor de servicios autorizado realice la sustitución de estos componentes. Dichos componentes se identifican con la palabra “No” en el catálogo ilustrado de componentes.

¹Mandatory: Verplicht—Onderdelen waarvoor Customer Self Repair verplicht is. Als u HP verzoekt deze onderdelen te vervangen, komen de reiskosten en het arbeidsloon voor uw rekening.

²Optional: Optioneel—Onderdelen waarvoor reparatie door de klant optioneel is. Ook deze onderdelen zijn ontworpen voor reparatie door de klant. Als u echter HP verzoekt deze onderdelen voor u te vervangen, kunnen daarvoor extra kosten in rekening worden gebracht, afhankelijk van het type garanteservice voor het product.

³No: Nee—Sommige HP onderdelen zijn niet ontwikkeld voor reparatie door de klant. In verband met de garantievooraarden moet het onderdeel door een geautoriseerde Service Partner worden vervangen. Deze onderdelen worden in de geïllustreerde onderdelencatalogus aangemerkt met "Nee".

¹Mandatory: Obrigatória—Peças cujo reparo feito pelo cliente é obrigatório. Se desejar que a HP substitua essas peças, serão cobradas as despesas de transporte e mão-de-obra do serviço.

²Optional: Opcional—Peças cujo reparo feito pelo cliente é opcional. Essas peças também são projetadas para o reparo feito pelo cliente. No entanto, se desejar que a HP as substitua, pode haver ou não a cobrança de taxa adicional, dependendo do tipo de serviço de garantia destinado ao produto.

³No: Nenhuma—Algumas peças da HP não são projetadas para o reparo feito pelo cliente. A fim de cumprir a garantia do cliente, a HP exige que um técnico autorizado substitua a peça. Essas peças estão identificadas com a marca “No” (Não), no catálogo de peças ilustrado.

¹Mandatory : 必須 - 顧客自己修理が必須の部品。当該部品について、もしもお客様がHPに交換作業を依頼される場合には、その修理サービスに関する交通費および人件費がお客様に請求されます。

²Optional : 任意 - 顧客自己修理が任意である部品。この部品も顧客自己修理用です。当該部品について、もしもお客様がHPに交換作業を依頼される場合には、お買い上げの製品に適用される保証サービス内容の範囲内においては、費用を負担していただくことなく保証サービスを受けることができます。

³No : 除外 - HP製品の一部の部品は、顧客自己修理用ではありません。製品の保証を継続するためには、HPまたはHP正規保守代理店による交換作業が必須となります。部品カタログには、当該部品が顧客自己修理除外品である旨が記載されています。

¹Mandatory: 强制性的 — 要求客户必须自行维修的部件。如果您请求 HP 更换这些部件，则必须为该服务支付差旅费和人工费用。

²Optional: 可选的 — 客户可以选择是否自行维修的部件。这些部件也是为客户自行维修设计的。不过，如果您要求 HP 为您更换这些部件，则根据您的产品指定的保修服务类型，HP 可能收取或不再收取任何附加费用。

³No: 否 — 某些 HP 部件的设计并未考虑客户自行维修。为了满足客户保修的需要，HP 要求授权服务提供商更换相关部件。这些部件在部件图解目录中标记为“否”。

¹Mandatory: 強制的 — 客戶自行維修所使用的零件是強制性的。如果您要求 HP 更換這些零件，HP 將會向您收取此服務所需的外出費用與勞動成本。

²Optional: 選購的 — 客戶自行維修所使用的零件是選購的。這些零件也設計用於客戶自行維修之用。不過，如果您要求 HP 為您更換，則可能需要也可能不需要負擔額外的費用，端視針對此產品指定的保固服務類型而定。

³No: 否 — 某些 HP 零件沒有消費者可自行維修的設計。為符合客戶保固，HP 需要授權的服務供應商更換零件。這些零件在圖示的零件目錄中，被標示為「否」。

¹ Mandatory: 필수 — 고객 셀프 수리가 의무 사항인 필수 부품. 사용자가 HP에 이 부품의 교체를 요청할 경우 이 서비스에 대한 출장비 및 작업비가 청구됩니다.

² Optional: 옵션 — 고객 셀프 수리가 선택 사항인 부품. 이 부품들도 고객 셀프 수리가 가능하도록 설계되었습니다. 하지만 사용자가 HP에 이 부품의 교체를 요청할 경우 사용자가 구입한 제품에 해당하는 보증 서비스 유형에 따라 추가 비용 없이 교체가 가능할 수 있습니다.

³ No: No — 고객 셀프 수리가 불가능하도록 설계된 HP 부품. 이 부품들은 고객 셀프 수리가 불가능하도록 설계되었습니다. HP는 고객 보증을 만족시키기 위해 공인 서비스 제공업체를 통해 부품을 교체하도록 하고 있습니다.

Removal and replacement procedures

Required tools

You need the following items for some procedures:

- T-10 Torx screwdriver
- T-15 Torx screwdriver
- HP Insight Diagnostics software ("[HP Insight Diagnostics](#)" on page 50)

Preparation procedures

To access some components and perform certain service procedures, you must perform one or more of the following procedures:

- Power down the nodes ("[Power down the node](#)" on page 22).
If you must remove the chassis from a rack or a non-hot-plug component from the chassis or node, then you must power down the nodes.
- Remove the nodes from the chassis ("[Remove a node from the chassis](#)" on page 23).
If the rack environment, cabling configuration, or the chassis location in the rack creates unstable conditions, then remove the node from the chassis.
- Remove the access panel (on page 24).
- Install the access panel (on page 24).

Power down the node

Before powering down the node for any upgrade or maintenance procedures, perform a backup of critical server data and programs.



IMPORTANT: When the node is in standby mode, auxiliary power is still being provided to the system.

To power down the node, use one of the following methods:

- Press and release the Power On/Standby button.
This method initiates a controlled shutdown of applications and the OS before the node enters standby mode.
- Press and hold the Power On/Standby button for more than 4 seconds to force the node to enter standby mode.
This method forces the node to enter standby mode without properly exiting applications and the OS. If an application stops responding, you can use this method to force a shutdown.
- Use a virtual power button selection through iLO.

This method initiates a controlled remote shutdown of applications and the OS before the node enters standby mode.

Before proceeding, verify the node is in standby mode by observing that the system power LED is amber.

Remove a node from the chassis

1. Power down the node (on page 22).

CAUTION: To avoid damage to the node, always support the bottom of the node when removing it from the chassis.

2. Remove the node from the chassis:
 - a. Press the release button.
 - b. Lower the handle.
 - c. Remove the node.

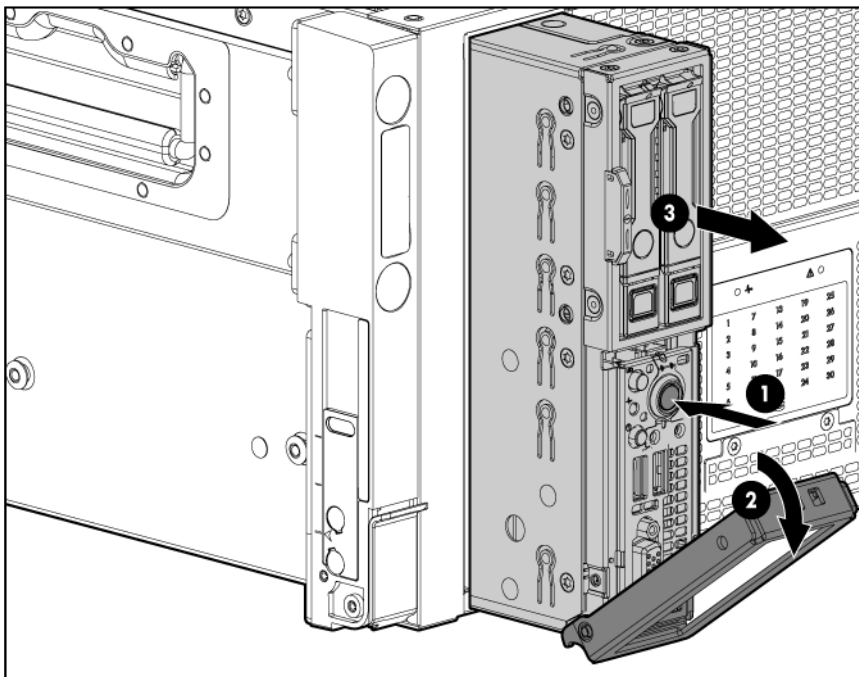

CAUTION: To avoid damage to the device, do not use the removal handle to carry it.

3. Place the node on a flat, level surface.

Installing a node into the chassis

Install the component as indicated.

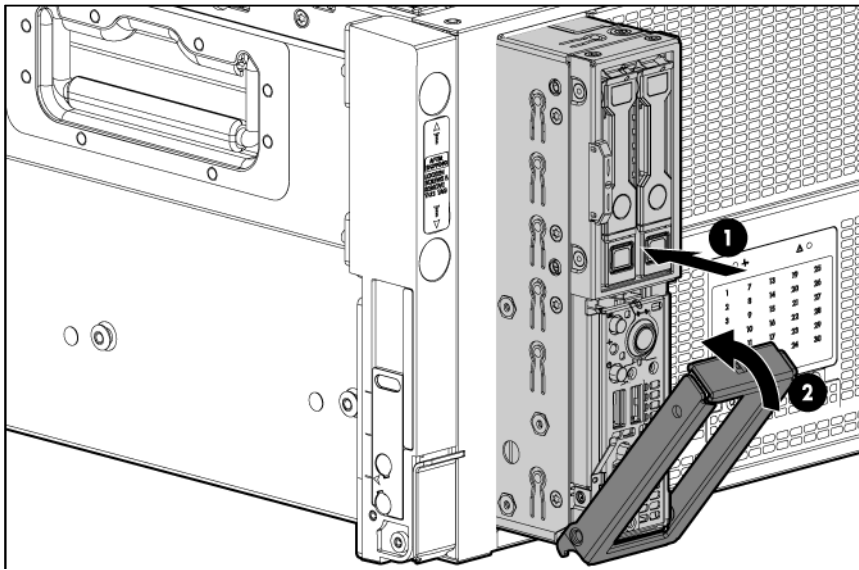

Remove the access panel

To remove the component:

1. Power down the node (on page 22).
2. Remove the node ("Remove a node from the chassis" on page 23).
3. Press the access panel release button.
4. Slide the access panel towards the rear of the node, and then lift to remove the panel.

Install the access panel

1. Place the access panel on top of the node.
2. Slide the access panel forward until it clicks into place.

Safety considerations

Before performing service procedures, review all the safety information.

Preventing electrostatic discharge

To prevent damaging the system, be aware of the precautions you need to follow when setting up the system or handling parts. A discharge of static electricity from a finger or other conductor may damage system boards or other static-sensitive devices. This type of damage may reduce the life expectancy of the device.

To prevent electrostatic damage:

- Avoid hand contact by transporting and storing products in static-safe containers.
- Keep electrostatic-sensitive parts in their containers until they arrive at static-free workstations.
- Place parts on a grounded surface before removing them from their containers.
- Avoid touching pins, leads, or circuitry.

- Always be properly grounded when touching a static-sensitive component or assembly.

Symbols on equipment

The following symbols may be placed on equipment to indicate the presence of potentially hazardous conditions.

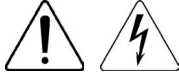

This symbol indicates the presence of hazardous energy circuits or electric shock hazards. Refer all servicing to qualified personnel.

WARNING: To reduce the risk of injury from electric shock hazards, do not open this enclosure. Refer all maintenance, upgrades, and servicing to qualified personnel.



This symbol indicates the presence of electric shock hazards. The area contains no user or field serviceable parts. Do not open for any reason.

WARNING: To reduce the risk of injury from electric shock hazards, do not open this enclosure.



This symbol on an RJ-45 receptacle indicates a network interface connection.

WARNING: To reduce the risk of electric shock, fire, or damage to the equipment, do not plug telephone or telecommunications connectors into this receptacle.

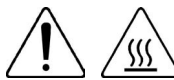

This symbol indicates the presence of a hot surface or hot component. If this surface is contacted, the potential for injury exists.

WARNING: To reduce the risk of injury from a hot component, allow the surface to cool before touching.

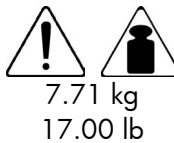

This symbol indicates that the component exceeds the recommended weight for one individual to handle safely.

WARNING: To reduce the risk of personal injury or damage to the equipment, observe local occupational health and safety requirements and guidelines for manual material handling.



These symbols, on power supplies or systems, indicate that the equipment is supplied by multiple sources of power.

WARNING: To reduce the risk of injury from electric shock, remove all power cords to completely disconnect power from the system.

Server warnings and cautions

Before installing a server, be sure that you understand the following warnings and cautions.



WARNING: To reduce the risk of electric shock or damage to the equipment:

- Do not disable the power cord grounding plug. The grounding plug is an important safety feature.
- Plug the power cord into a grounded (earthed) electrical outlet that is easily accessible at all times.
- Unplug the power cord from the power supply to disconnect power to the equipment.
- Do not route the power cord where it can be walked on or pinched by items placed against it. Pay particular attention to the plug, electrical outlet, and the point where the cord extends from the server.



WARNING: To reduce the risk of personal injury from hot surfaces, allow the drives and the internal system components to cool before touching them.



CAUTION: Do not operate the node for long periods with the access panel open or removed. Operating the node in this manner results in improper airflow and improper cooling that can lead to thermal damage.

Drive blank

Remove the component as indicated.

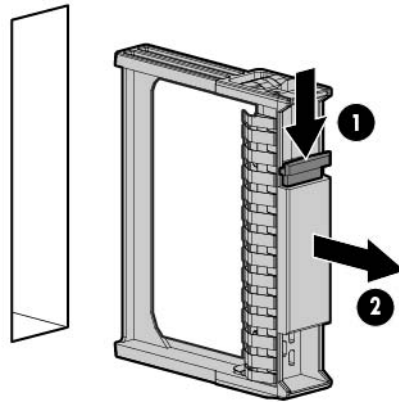

CAUTION: To prevent improper cooling and thermal damage, do not operate the server unless all bays are populated with either a component or a blank.

To replace the component, slide the component into the bay until it clicks.

Drive

To remove the component:

1. Determine the status of the drive from the drive LED definitions ("[Hot-plug drive LED definitions](#)" on page 53).
2. Back up all data on the drive.

3. Remove the drive.

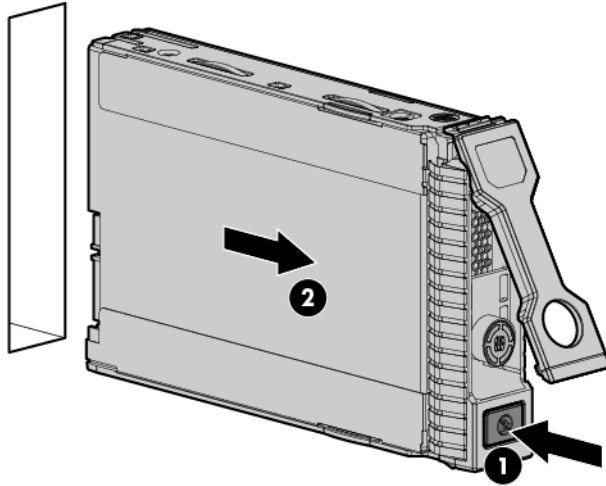

To replace the component:



CAUTION: To prevent improper cooling and thermal damage, do not operate the HP ProLiant SL4500 Series unless all drive and device bays are populated with either a component or a blank.

1. Prepare the drive.

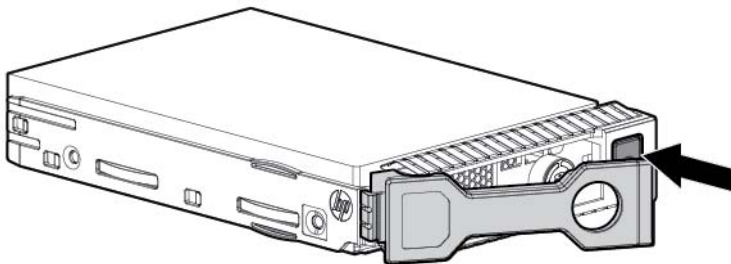

2. Install the drive.

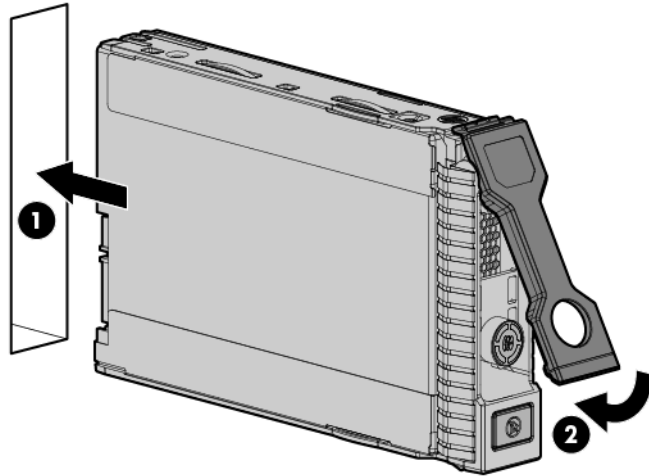

3. Determine the status of the drive from the drive LED definitions ("[Hot-plug drive LED definitions](#)" on page 53).

DIMMs

To remove the component:

1. Power down the node (on page 22).
2. Remove the node from the chassis ("[Remove a node from the chassis](#)" on page 23).
3. Remove the access panel (on page 24).
4. Remove the DIMM.

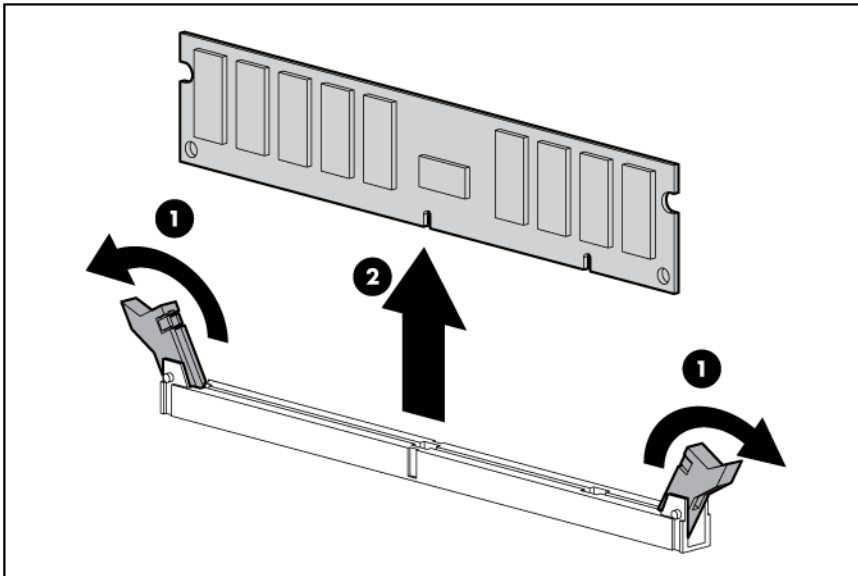

To replace the component, reverse the removal procedure.

Heatsink

To remove the component:

△ CAUTION: The heatsink thermal interface media is not reusable and must be replaced if the heatsink is removed from the processor after it has been installed.

1. Power down the node (on page 22).
2. Remove the node from the chassis ("Remove a node from the chassis" on page 23).
3. Remove the access panel (on page 24).
4. Remove the heatsink.

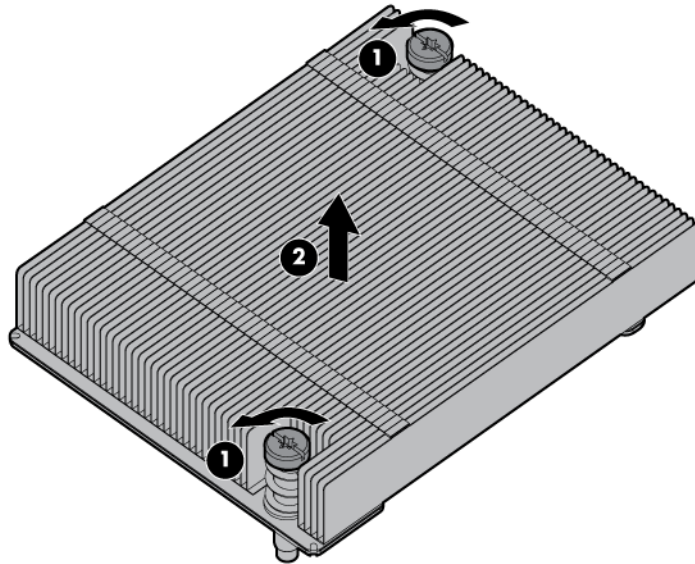

To replace the component:

1. Use the alcohol swab to remove all the existing thermal grease from the processor. Allow the alcohol to evaporate before continuing.

2. Remove the thermal interface protective cover from the heatsink.

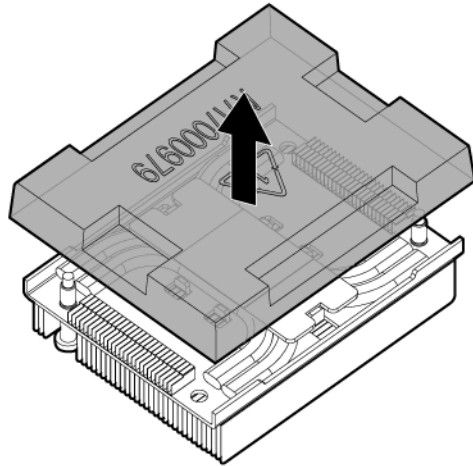

CAUTION: To avoid damage to the system board, processor socket, and screws, do not overtighten the heatsink screws. Use the wrench supplied with the system to reduce the possibility of overtightening the screws.

3. Install the heatsink.

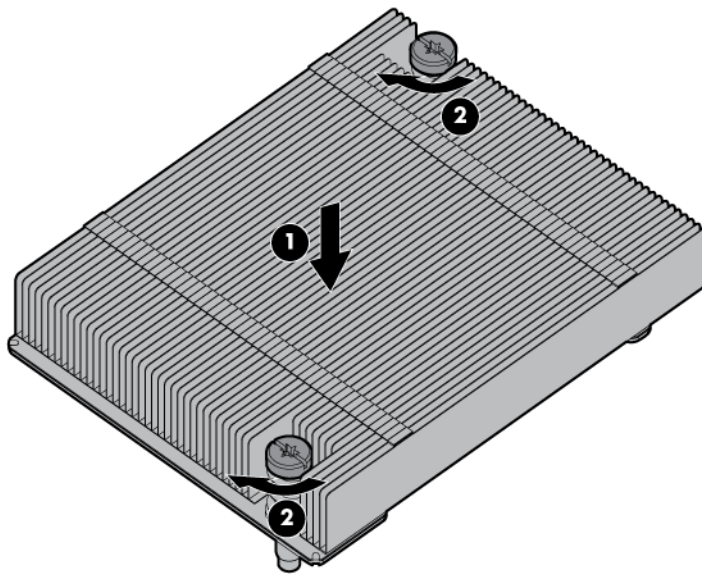

4. Install the access panel (on page 24).
5. Install the node into the chassis ("[Installing a node into the chassis](#)" on page 23).
6. Power up the node.

Processor



WARNING: To reduce the risk of personal injury from hot surfaces, allow the drives and the internal system components to cool before touching them.



CAUTION: To prevent possible node malfunction and damage to the equipment, multiprocessor configurations must contain processors with the same part number.



CAUTION: To avoid damage to the processor and system board, only authorized personnel should attempt to replace or install the processor in this node.



CAUTION: The heatsink thermal interface media is not reusable and must be replaced if the heatsink is removed from the processor after it has been installed.



IMPORTANT: Processor socket 1 must be populated at all times or the node does not function.

To remove the component:

1. Power down the node (on page 22).
2. Remove the node from the chassis ("Remove a node from the chassis" on page 23).
3. Place the node on a flat, level work surface.
4. Remove the access panel (on page 24).
5. Remove the heatsink.

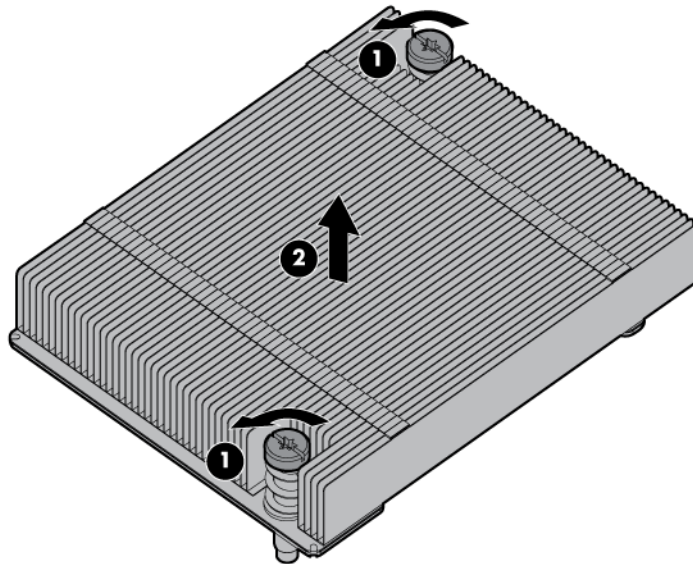

IMPORTANT: To avoid forcibly ejecting the processor, open the levers slowly.

6. Open each of the processor locking levers in the order indicated, and then open the processor retaining bracket.

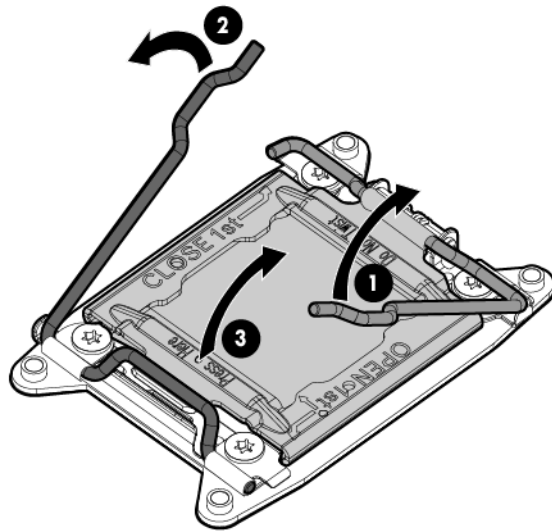

7. Remove the processor from the processor retaining bracket.

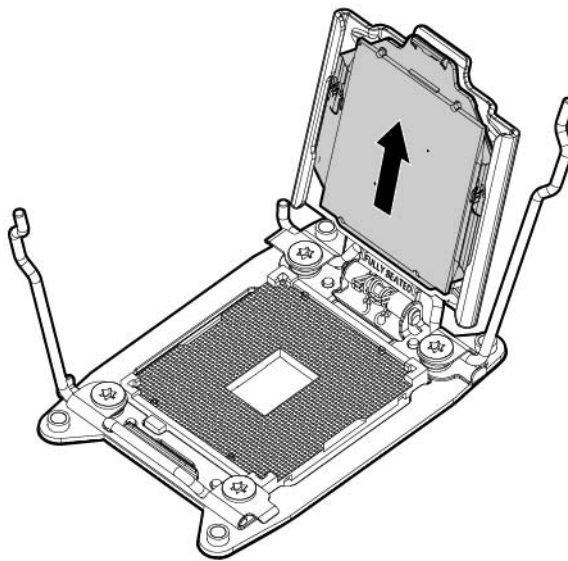

CAUTION: To avoid damage to the processor, do not touch the bottom of the processor, especially the contact area.

8. Install the processor. Verify that the processor is fully seated in the processor retaining bracket by visually inspecting the processor installation guides on either side of the processor. **THE PINS ON THE SYSTEM BOARD ARE VERY FRAGILE AND EASILY DAMAGED.**

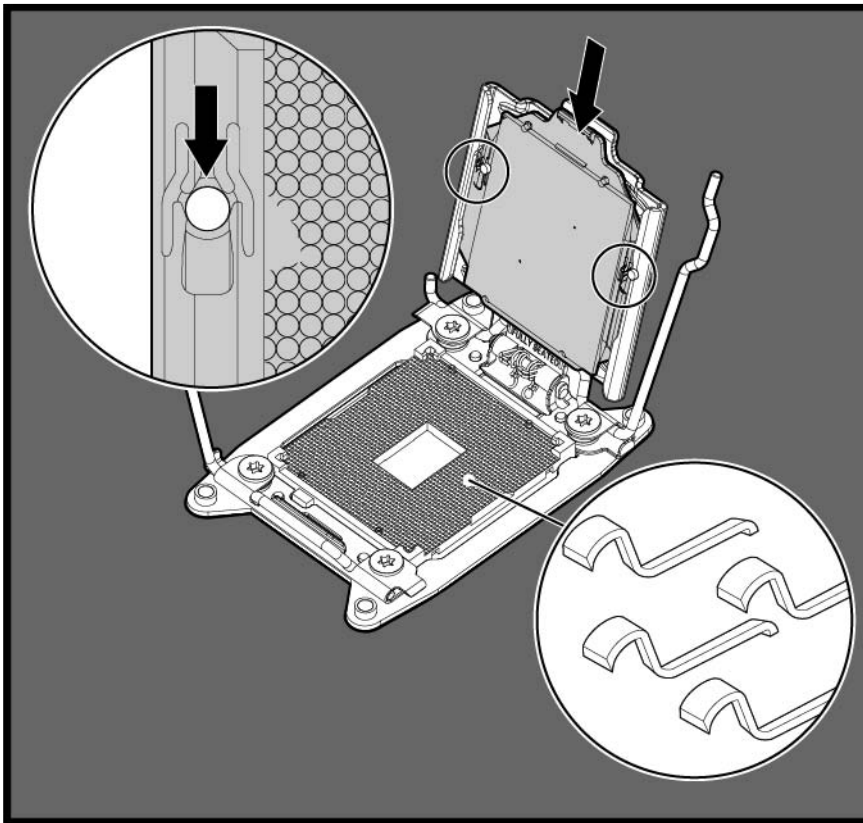

CAUTION: THE PINS ON THE SYSTEM BOARD ARE VERY FRAGILE AND EASILY DAMAGED. To avoid damage to the system board, do not touch the processor or the processor socket contacts.

9. Close the processor retaining bracket. When the processor is installed properly inside the processor retaining bracket, the processor retaining bracket clears the flange on the front of the socket.

CAUTION: Do not press down on the processor. Pressing down on the processor may cause damage to the processor socket and the system board. Press only in the area indicated on the processor retaining bracket.

10. Press and hold the processor retaining bracket in place, and then close each processor locking lever. Press only in the area indicated on the processor retaining bracket.

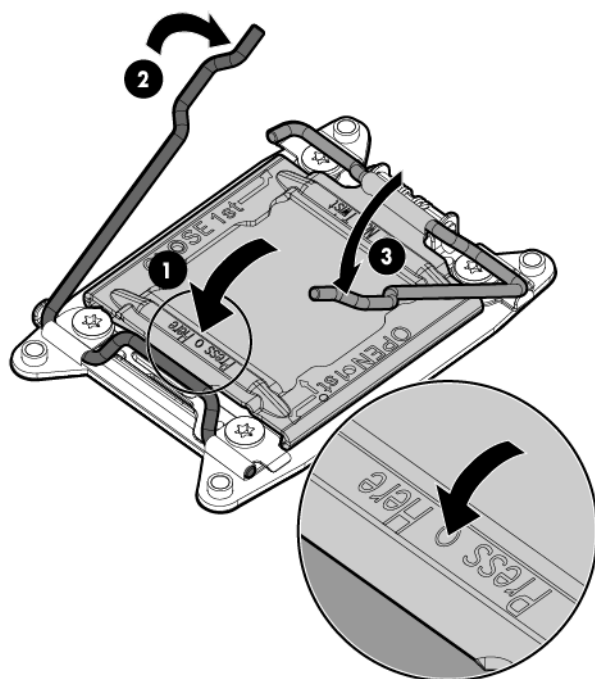

11. Use the alcohol swab to remove all the existing thermal grease from the heatsink. Allow the alcohol to evaporate before continuing.
12. Apply the thermal grease to the top of the processor in the following pattern.

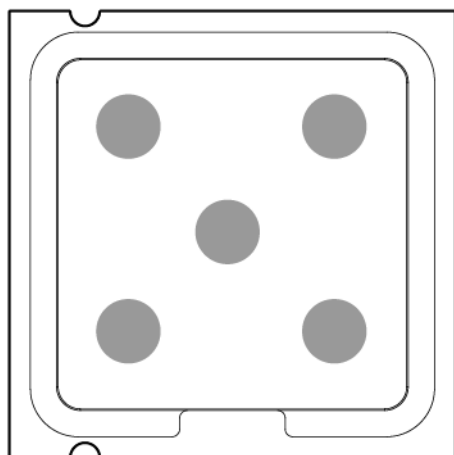

CAUTION: To avoid damage to the system board, processor socket, and screws, do not overtighten the heatsink screws. Use the wrench supplied with the system to reduce the possibility of overtightening the screws.

13. Install the heatsink.

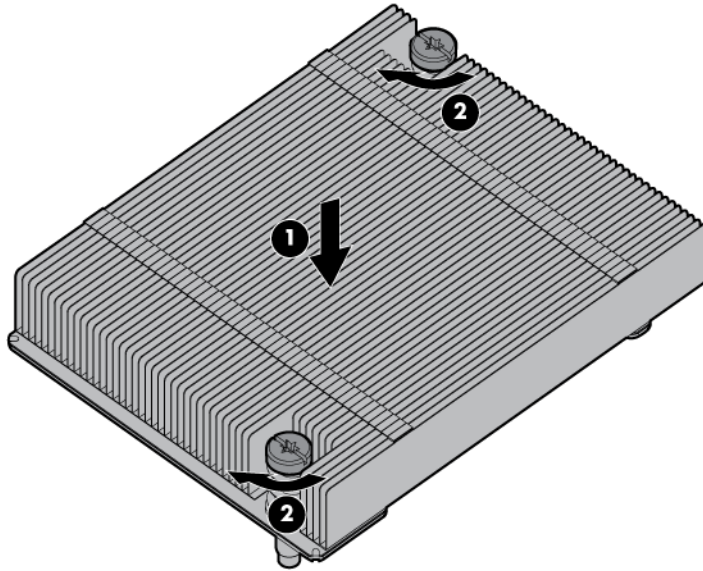

14. Install the access panel (on page 24).
15. Install the node into the chassis ("[Installing a node into the chassis](#)" on page 23).
16. Power up the server.

SFF backplane board

To remove the component:

1. Power down the node (on page 22).
2. Remove the node from the chassis ("[Remove a node from the chassis](#)" on page 23).
3. Remove the access panel (on page 24).
4. Disconnect all cables from the SFF backplane board.
5. Remove the two screws securing the board to the node.

6. Remove the board.

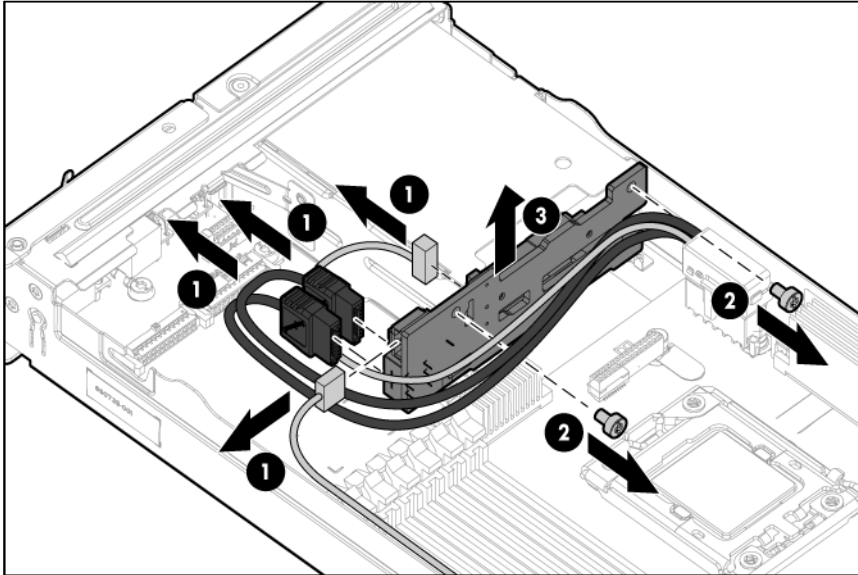

To replace the component, reverse the removal procedure.

Front panel board

To remove the component:

1. Power down the node (on page 22).
2. Remove the node from the chassis ("[Remove a node from the chassis](#)" on page 23).
3. Remove the access panel (on page 24).
4. Disconnect all cables from the front panel board.
5. Remove the three screws securing the front panel board to the node.
6. Remove the board.

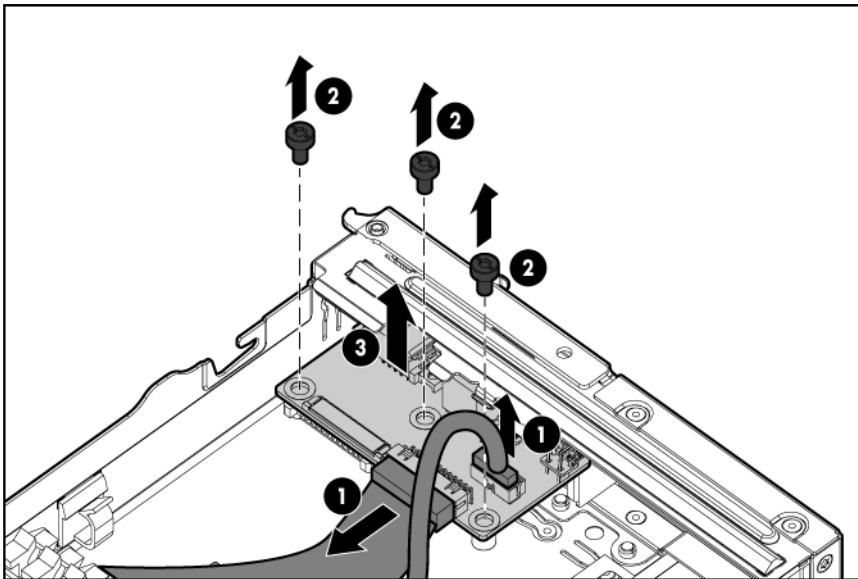

To replace the component, reverse the removal procedure.

Personality board assembly

To remove the component:

1. Power down the node (on page 22).
2. Remove the node from the chassis ("Remove a node from the chassis" on page 23).
3. Remove the access panel (on page 24).
4. Disconnect all cables connected to the top of the personality board.

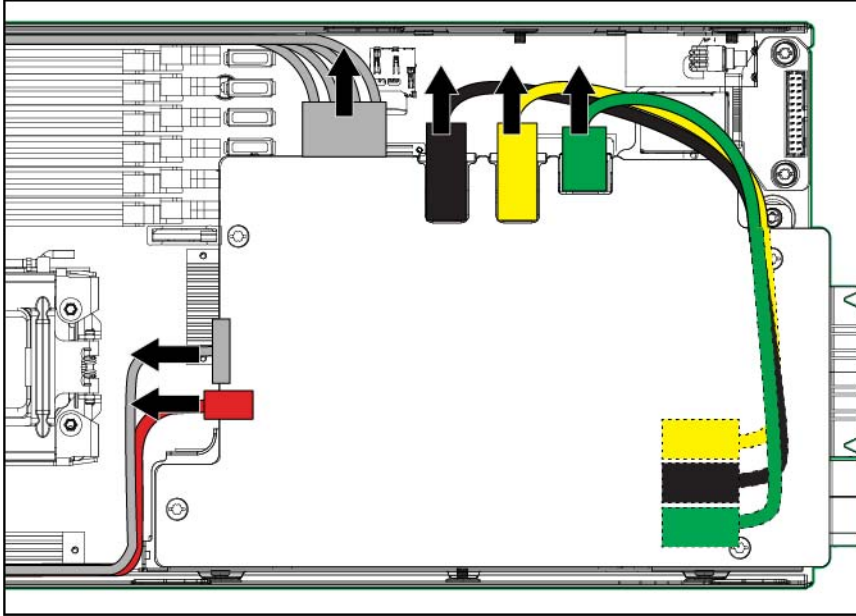

5. Remove the screws securing the personality board assembly to the node.



CAUTION: Do not remove the four screws that secure the personality board to the bracket. Only remove the screws that secure the personality board assembly to the system board.

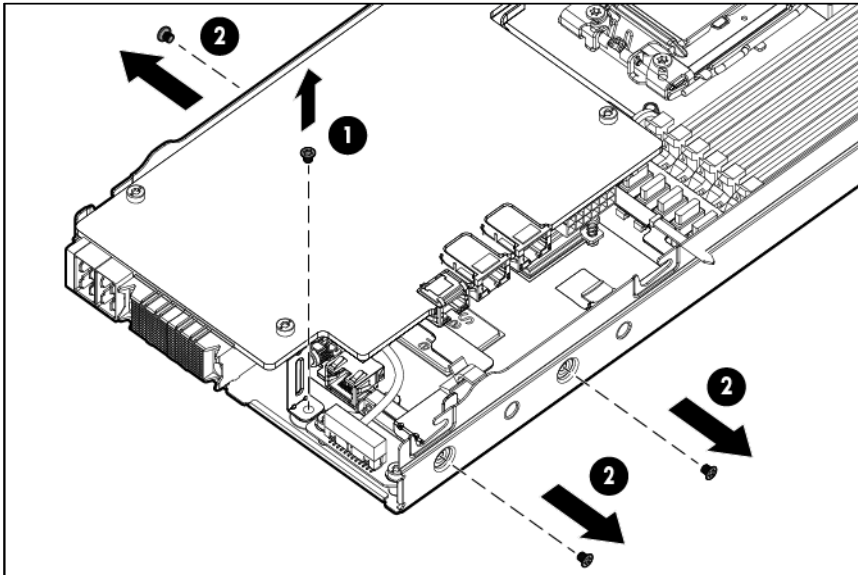

6. Disconnect all cables connected to the underside of the personality board assembly.

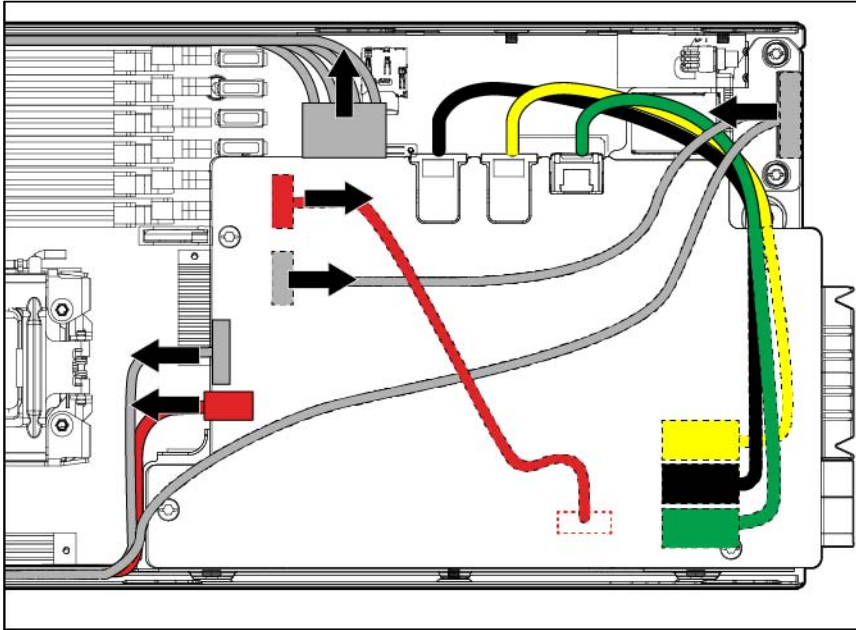

7. Remove the personality board assembly.

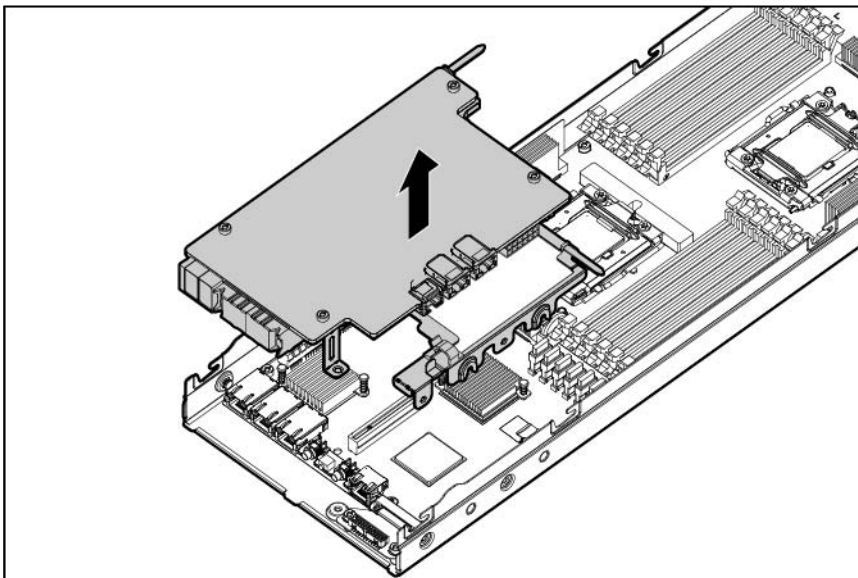

To replace the component, reverse the removal procedure.

SUV interface board

To remove the component:

1. Power down the node (on page 22).
2. Remove the node from the chassis ("[Remove a node from the chassis](#)" on page 23).
3. Remove the access panel (on page 24).
4. Remove the two screws securing the board to the node.
5. Disconnect all cables.

6. Remove the board.

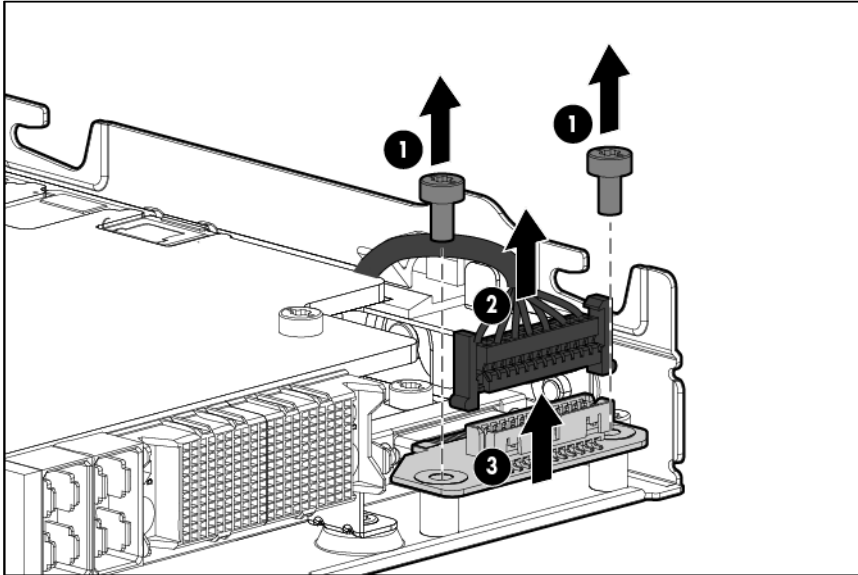

To replace the component, reverse the removal procedure.

System board

To remove the component:

1. Power down the node (on page 22).
2. Remove the node from the chassis ("[Remove a node from the chassis](#)" on page 23).
3. Remove the access panel (on page 24).
4. Remove all DIMMs ("[DIMMs](#)" on page 28).
5. Remove all heatsinks.

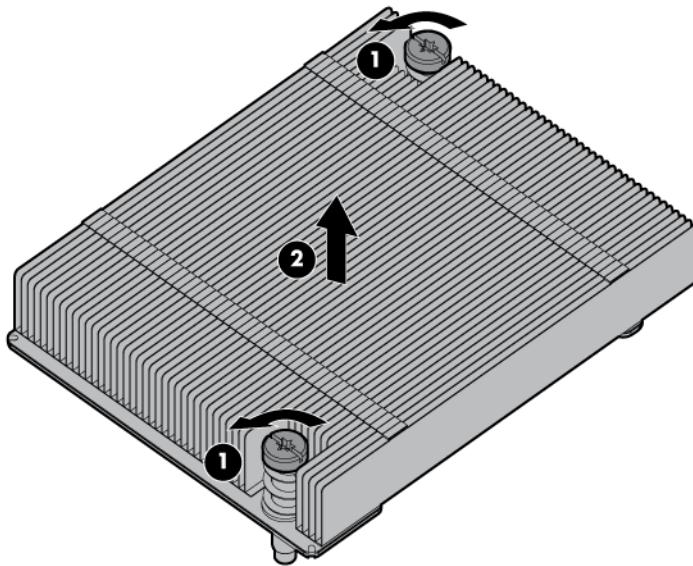

CAUTION: The heatsink thermal interface media is not reusable and must be replaced if the heatsink is removed from the processor after it has been installed.



IMPORTANT: To avoid forcibly ejecting the processor, open the levers slowly.

6. Open each of the processor locking levers in the order indicated, and then open the processor retaining bracket.

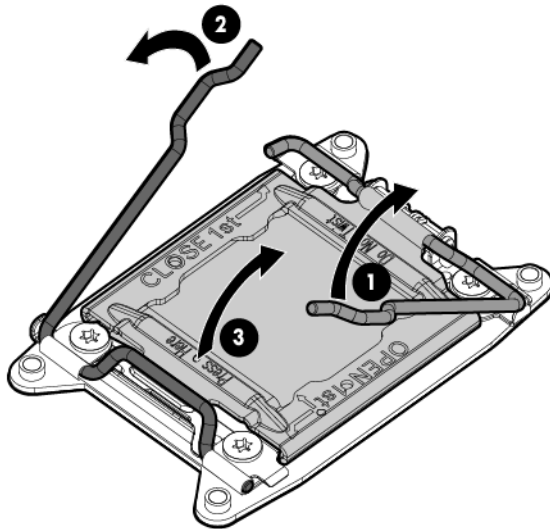

7. Remove the processor from the processor retaining bracket.

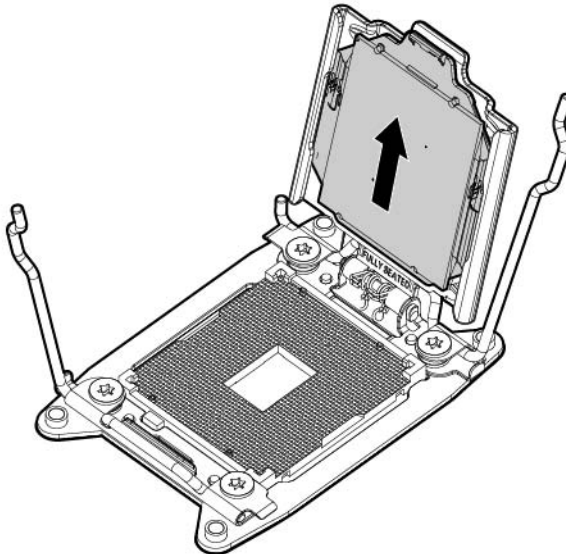

CAUTION: To avoid damage to the processor, do not touch the bottom of the processor, especially the contact area.

8. Remove the personality board assembly (on page 37).
9. Remove the SUV interface board (on page 38).

10. Disconnect all cables from the system board.

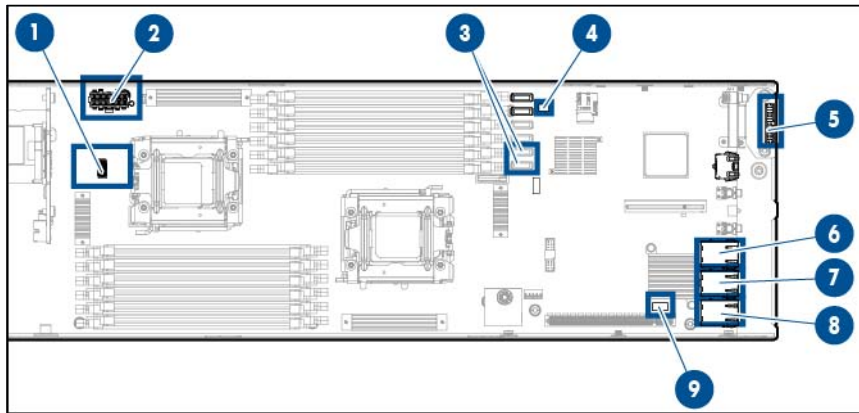

| Item | Description |
|------|--------------------|
| 1 | RPS cable |
| 2 | Power cable |
| 3 | SATA cables |
| 4 | HDD data LED cable |
| 5 | SUB/VGA cable |
| 6 | NIC 1 cable |
| 7 | NIC 2 cable |
| 8 | iLO cable |
| 9 | LED cable |

11. Remove the header cover.

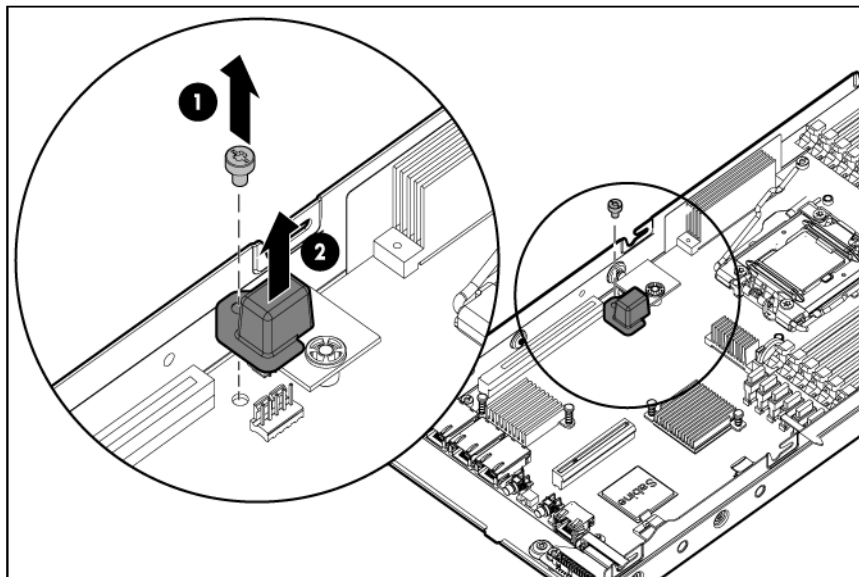

12. Remove the failed system board.

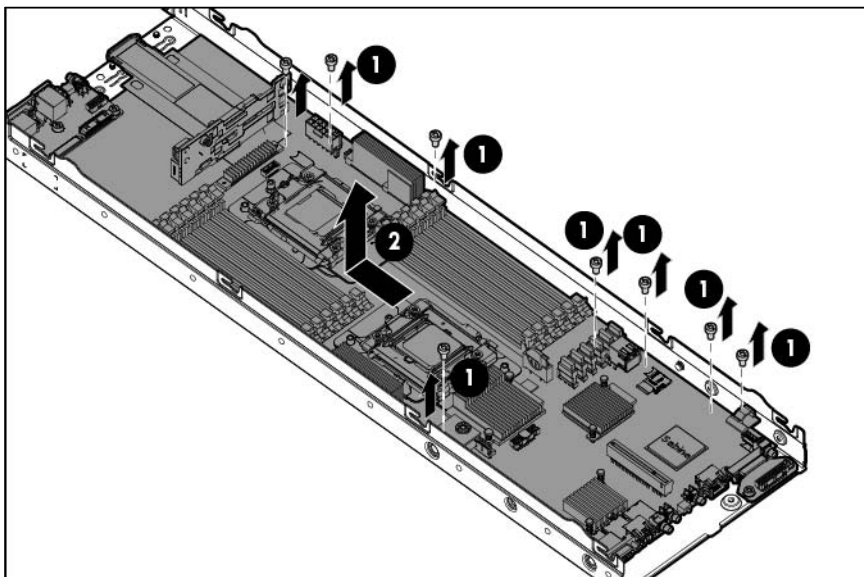

To replace the system board:

1. Align the system board on the tray, and then install the header cover.
2. Install the screws.

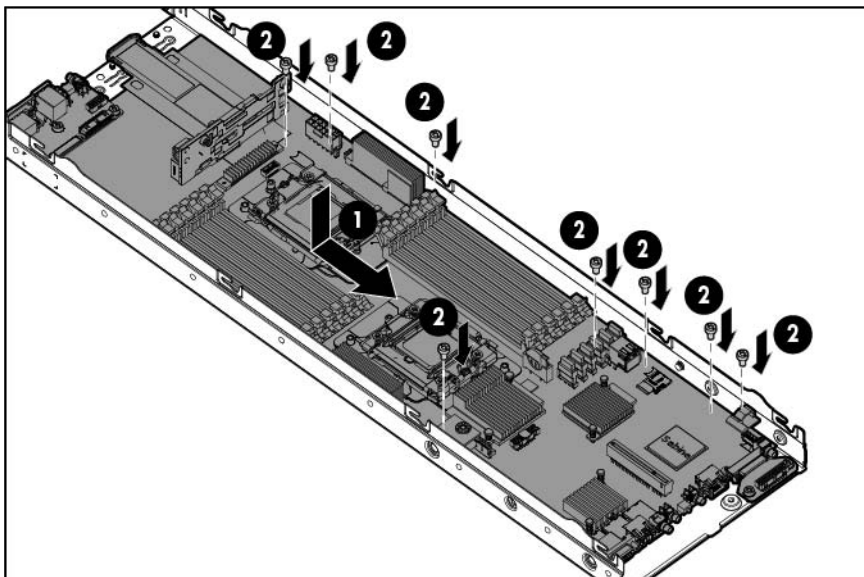

3. Connect all cables to the system board.

4. Open each of the processor locking levers in the order indicated, and then open the processor retaining bracket.

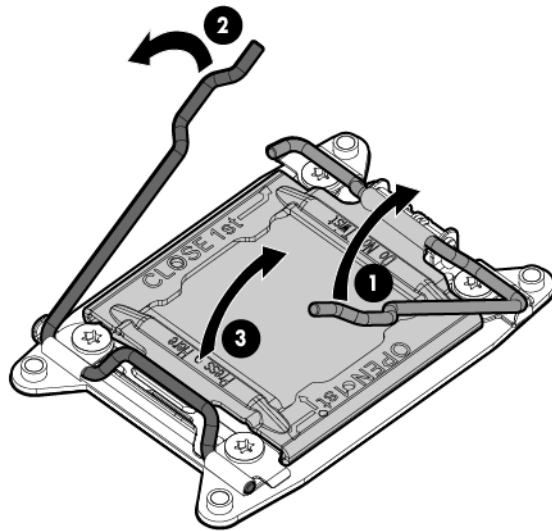

5. Remove the clear processor socket cover. Retain the processor socket cover for future use.

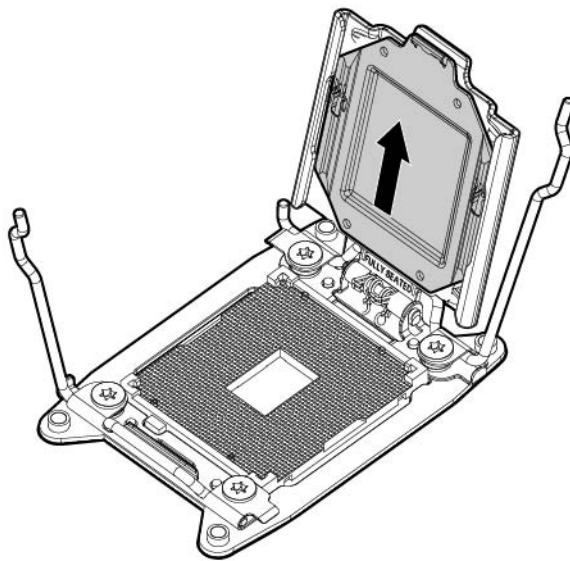

6. Install the processor. Verify that the processor is fully seated in the processor retaining bracket by visually inspecting the processor installation guides on either side of the processor. **THE PINS ON THE SYSTEM BOARD ARE VERY FRAGILE AND EASILY DAMAGED.**

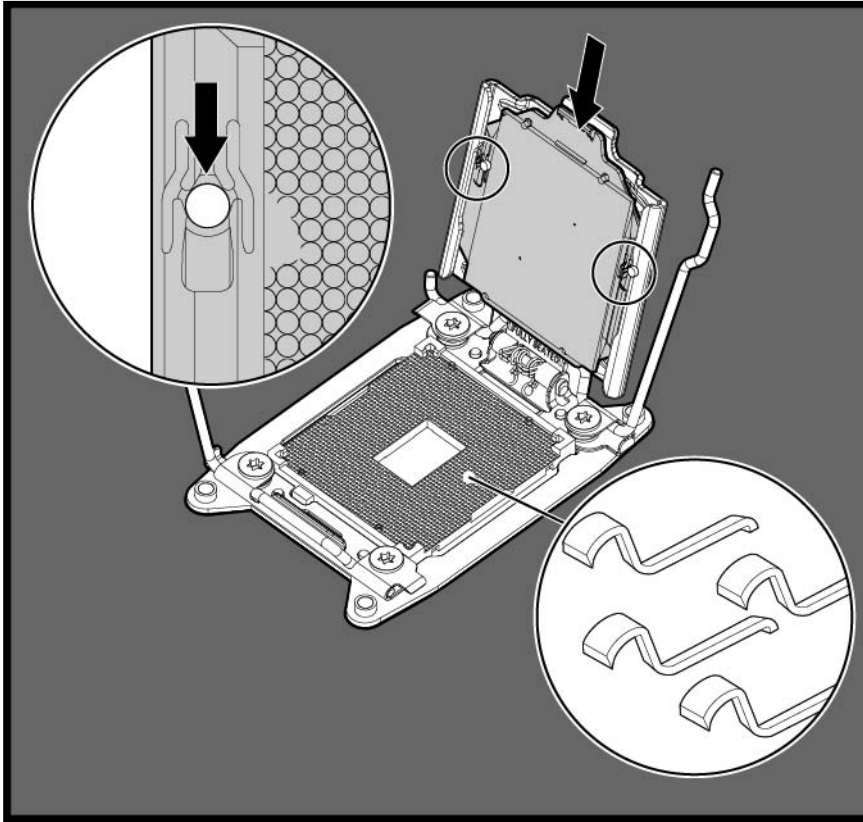

CAUTION: THE PINS ON THE SYSTEM BOARD ARE VERY FRAGILE AND EASILY DAMAGED. To avoid damage to the system board, do not touch the processor or the processor socket contacts.

7. Close the processor retaining bracket. When the processor is installed properly inside the processor retaining bracket, the processor retaining bracket clears the flange on the front of the socket.

CAUTION: Do not press down on the processor. Pressing down on the processor may cause damage to the processor socket and the system board. Press only in the area indicated on the processor retaining bracket.

8. Press and hold the processor retaining bracket in place, and then close each processor locking lever. Press only in the area indicated on the processor retaining bracket.

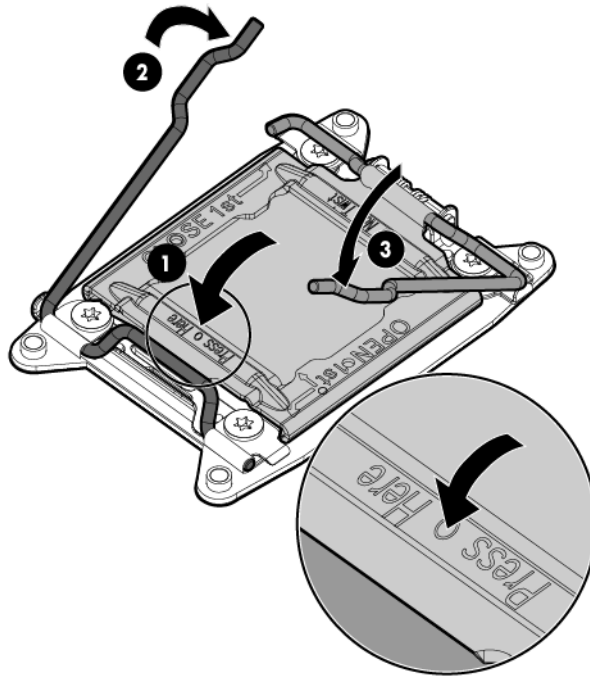

9. Install the processor socket cover onto the processor socket of the failed system board.
10. Clean the old thermal grease from the heatsink and the top of the processor with the alcohol swab. Allow the alcohol to evaporate before continuing.
11. Apply all the grease to the top of the processor in the following pattern to ensure even distribution.

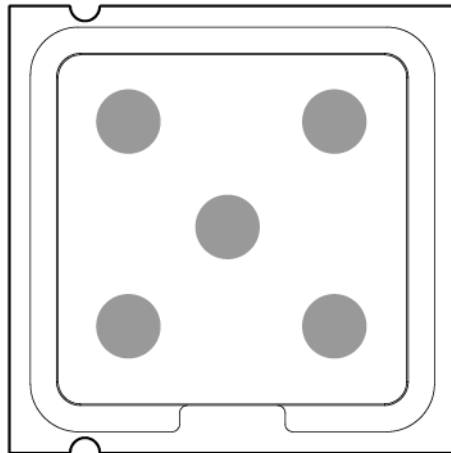

CAUTION: To avoid damage to the system board, processor socket, and screws, do not overtighten the heatsink screws. Use the wrench supplied with the system to reduce the possibility of overtightening the screws.

12. Install the heatsink.

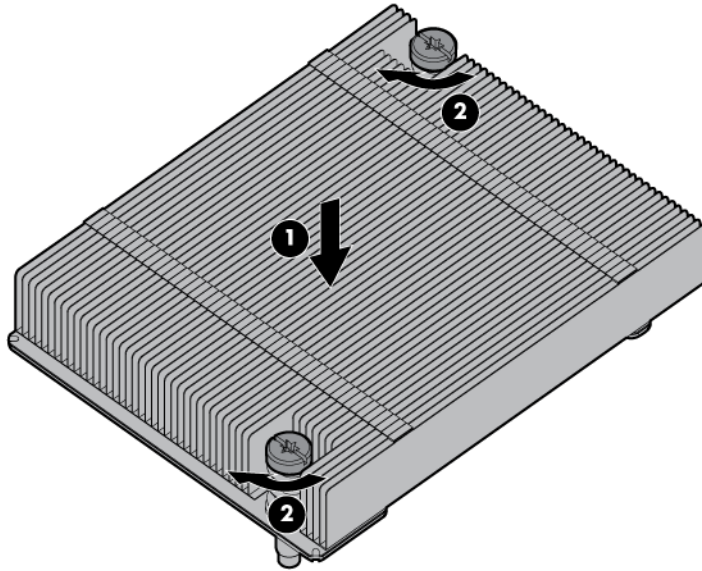

13. Install the DIMMs (on page 28).
14. Install the personality board assembly (on page 37).
15. Install the SUV interface board (on page 38).
16. Install the access panel (on page 24).
17. Install the node into the chassis ("Installing a node into the chassis" on page 23).
18. Power up the node.

After you replace the system board, you must re-enter the node serial number and the product ID.

1. During the node startup sequence, press the **F9** key to access RBSU.
2. Select the **Advanced Options** menu.
3. Select **Service Options**.
4. Select **Serial Number**. The following warning appears:
Warning: The serial number should ONLY be modified by qualified service personnel. This value should always match the serial number located on the chassis.
5. Press the **Enter** key to clear the warning.
6. Enter the serial number and press the **Enter** key.
7. Select **Product ID**. The following warning appears:
Warning: The Product ID should ONLY be modified by qualified service personnel. This value should always match the Product ID located on the chassis.
8. Enter the product ID and press the **Enter** key.
9. Press the **Esc** key to close the menu.
10. Press the **Esc** key to exit RBSU.
11. Press the **F10** key to confirm exiting RBSU. The node automatically reboots.

System battery

If the node no longer automatically displays the correct date and time, you might have to replace the battery that provides power to the real-time clock. Under normal use, battery life is 5 to 10 years.



WARNING: The computer contains an internal lithium manganese dioxide, a vanadium pentoxide, or an alkaline battery pack. A risk of fire and burns exists if the battery pack is not properly handled. To reduce the risk of personal injury:

- Do not attempt to recharge the battery.
- Do not expose the battery to temperatures higher than 60°C (140°F).
- Do not disassemble, crush, puncture, short external contacts, or dispose of in fire or water.
- Replace only with the spare designated for this product.

To remove the component:

1. Power down the node (on page 22).
2. Remove the node from the chassis ("Remove a node from the chassis" on page 23).
3. Remove the access panel (on page 24).
4. Locate the battery on the system board ("System board components" on page 54).
5. Remove the battery.

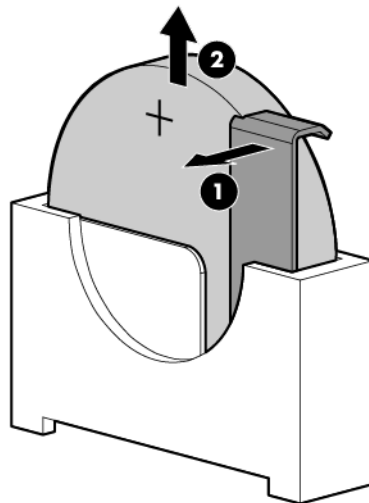

IMPORTANT: Replacing the system board battery resets the system ROM to its default configuration. After replacing the battery, reconfigure the system through RBSU.

To replace the component, reverse the removal procedure.

For more information about battery replacement or proper disposal, contact an authorized reseller or an authorized service provider.

HP Trusted Platform Module

The TPM is not a customer-removable part.



CAUTION: Any attempt to remove an installed TPM from the system board breaks or disfigures the TPM security rivet. Upon locating a broken or disfigured rivet on an installed TPM, administrators should consider the system compromised and take appropriate measures to ensure the integrity of the system data.

If you suspect a TPM board failure, leave the TPM installed and remove the system board ("[System board](#)" on page [39](#)). Contact an HP authorized service provider for a replacement system board and TPM board.

Troubleshooting

Troubleshooting resources

The *HP ProLiant Gen8 Troubleshooting Guide, Volume I: Troubleshooting* provides procedures for resolving common problems and comprehensive courses of action for fault isolation and identification, issue resolution, and software maintenance on ProLiant servers and server blades. To view the guide, select a language:

- English (http://www.hp.com/support/ProLiant_TSG_v1_en)
- French (http://www.hp.com/support/ProLiant_TSG_v1_fr)
- Spanish (http://www.hp.com/support/ProLiant_TSG_v1_sp)
- German (http://www.hp.com/support/ProLiant_TSG_v1_gr)
- Japanese (http://www.hp.com/support/ProLiant_TSG_v1_jp)
- Simplified Chinese (http://www.hp.com/support/ProLiant_TSG_v1_sc)

The *HP ProLiant Gen8 Troubleshooting Guide, Volume II: Error Messages* provides a list of error messages and information to assist with interpreting and resolving error messages on ProLiant servers and server blades. To view the guide, select a language:

- English (http://www.hp.com/support/ProLiant_EMG_v1_en)
- French (http://www.hp.com/support/ProLiant_EMG_v1_fr)
- Spanish (http://www.hp.com/support/ProLiant_EMG_v1_sp)
- German (http://www.hp.com/support/ProLiant_EMG_v1_gr)
- Japanese (http://www.hp.com/support/ProLiant_EMG_v1_jp)
- Simplified Chinese (http://www.hp.com/support/ProLiant_EMG_v1_sc)

Diagnostic tools

HP ROM-Based Setup Utility

RBSU is a configuration utility embedded in HP ProLiant servers that performs a wide range of configuration activities that can include the following:

- Configuring system devices and installed options
- Enabling and disabling system features
- Displaying system information
- Selecting the primary boot controller
- Configuring memory options
- Language selection

For more information on RBSU, see the *HP ROM-Based Setup Utility User Guide* on the Documentation CD or the HP RBSU Information Library (<http://www.hp.com/go/rbsu/docs>).

HP Insight Diagnostics

HP Insight Diagnostics is a proactive node management tool, available in both offline and online versions, that provides diagnostics and troubleshooting capabilities to assist IT administrators who verify node installations, troubleshoot problems, and perform repair validation.

HP Insight Diagnostics Offline Edition performs various in-depth system and component testing while the OS is not running. To run this utility, boot the node using Intelligent Provisioning.

HP Insight Diagnostics Online Edition is a web-based application that captures system configuration and other related data needed for effective node management. Available in Microsoft Windows and Linux versions, the utility helps to ensure proper system operation.

For more information or to download the utility, see the HP website (<http://www.hp.com/servers/diags>). HP Insight Diagnostics Online Edition is also available in the SPP.

Integrated Management Log

The IML records hundreds of events and stores them in an easy-to-view form. The IML timestamps each event with 1-minute granularity.

You can view recorded events in the IML in several ways, including the following:

- From within HP SIM
- From within operating system-specific IML viewers
 - For Windows: IML Viewer
 - For Linux: IML Viewer Application

- From within the iLO user interface
- From within HP Insight Diagnostics (on page 50)

HP Insight Remote Support software

HP strongly recommends that you register your device for remote support to enable enhanced delivery of your HP Warranty, HP Care Pack Service, or HP contractual support agreement. HP Insight Remote Support supplements your monitoring continuously to ensure maximum system availability by providing intelligent event diagnosis, and automatic, secure submission of hardware event notifications to HP, which will initiate a fast and accurate resolution, based on your product's service level. Notifications may be sent to your authorized HP Channel Partner for onsite service, if configured and available in your country.

For more information, see *HP Insight Remote Support and Insight Online Setup Guide for ProLiant Gen8 Servers and BladeSystem c-Class Enclosures* on the HP website (<http://www.hp.com/go/enterprise/docs>). HP Insight Remote Support is available as part of HP Warranty, HP Care Pack Service, or HP contractual support agreement.

Component identification

Front panel components

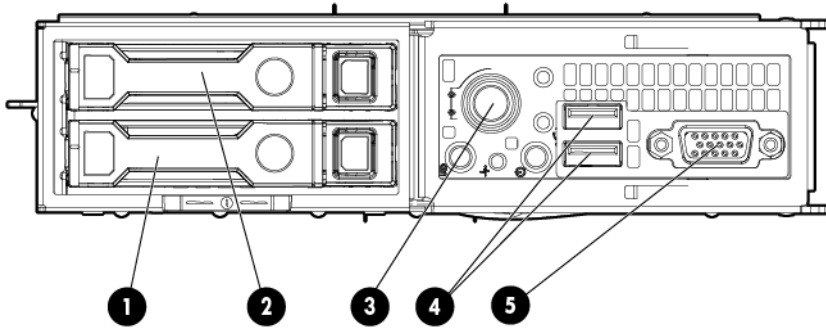

| Item | Description |
|------|---------------------|
| 1 | Hard drive bay 1 |
| 2 | Hard drive bay 2 |
| 3 | Node release button |
| 4 | USB connectors (2) |
| 5 | VGA connector |

Front panel LEDs and buttons

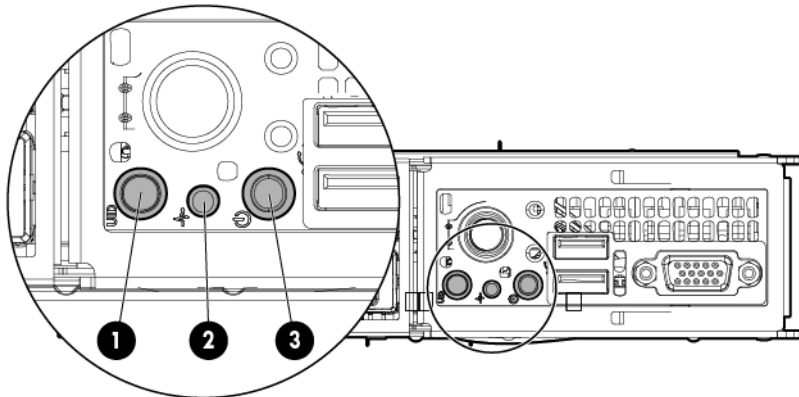

| Item | Description | Status |
|------|-------------------|--|
| 1 | UID LED button | Blue = Activated Flashing blue = System is being remotely managed or firmware update is in progress. Off = Deactivated |
| 2 | System Health LED | Green = Normal |

| Item | Description | Status |
|------|--|--|
| | | Flashing amber = System degraded Flashing red = System critical |
| 3 | Power On/Standby button and system power LED | Green = System on Amber = System is in Standby mode, but power is still applied. Off = Power is not connected, or power supply has failed. |

Hot-plug drive LED definitions

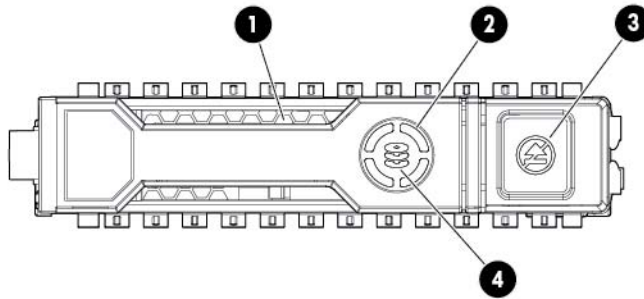

| Item | LED | Status | Definition |
|------|---------------|----------------------|--|
| 1 | Locate | Solid blue | The drive is being identified by a host application. |
| | | Flashing blue | The drive carrier firmware is being updated or requires an update. |
| 2 | Activity ring | Rotating green | Drive activity |
| | | Off | No drive activity |
| 3 | Do not remove | Solid white | Do not remove the drive. Removing the drive causes one or more of the logical drives to fail. |
| | | Off | Removing the drive does not cause a logical drive to fail. |
| 4 | Drive status | Solid green | The drive is a member of one or more logical drives. |
| | | Flashing green | The drive is rebuilding or performing a RAID migration, strip size migration, capacity expansion, or logical drive extension, or is erasing. |
| | | Flashing amber/green | The drive is a member of one or more logical drives and predicts the drive will fail. |
| | | Flashing amber | The drive is not configured and predicts the drive will fail. |
| | | Solid amber | The drive has failed. |
| | | Off | The drive is not configured by a RAID controller. |

System board components

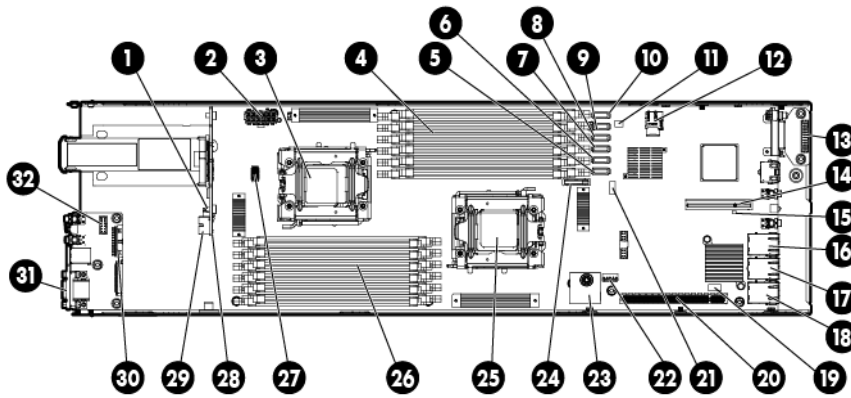

| Item | Description |
|------|----------------------------------|
| 1 | HDD data LED backplane connector |
| 2 | Power connector |
| 3 | Processor socket 2 |
| 4 | Processor 1 DIMM slots (6) |
| 5 | SATA HDD connector 1 |
| 6 | SATA HDD connector 2 |
| 7 | Reserved connector |
| 8 | Reserved connector |
| 9 | Reserved connector |
| 10 | Reserved connector |
| 11 | HDD data LED connector |
| 12 | MicroSD card slot |
| 13 | USB/VGA connector |
| 14 | Personality board connector 1 |
| 15 | NMI jumper |
| 16 | NIC 1 connector |
| 17 | NIC 2 connector |
| 18 | iLO connector |
| 19 | LED power connector |
| 20 | Personality board connector 2 |
| 21 | System maintenance switch |
| 22 | Internal USB connector |
| 23 | TPM connector |
| 24 | System battery |
| 25 | Processor socket 1 |
| 26 | Processor 2 DIMM slots (6) |
| 27 | RPS connector |
| 28 | SFF backplane power connector |
| 29 | SATA connectors (2) |
| 30 | Front panel USB/VGA connector |

| Item | Description |
|------|---------------------|
| 31 | VGA connector |
| 32 | Front LED connector |

DIMM slots

DIMM slots are numbered sequentially (1 through 6) for each processor. The supported AMP modes use the letter assignments for population guidelines.

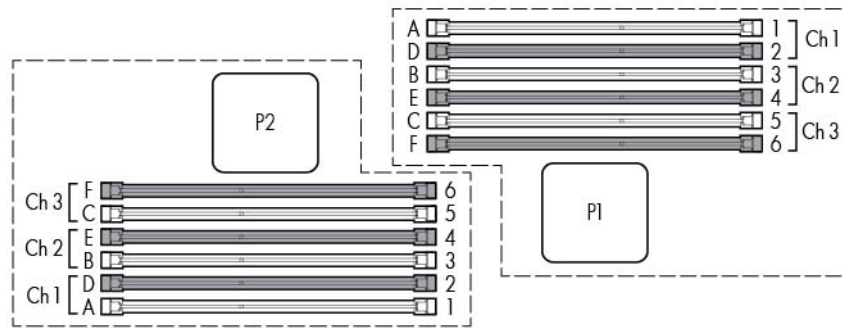

System maintenance switch

| Position | Default | Function |
|----------|---------|---|
| S1 | Off | Off = iLO security enabled On = iLO security disabled |
| S2 | Off | Off = System configuration unlocked On = System configuration locked |
| S3 | Off | Reserved |
| S4 | Off | Reserved |
| S5 | Off | Off = Power-on password enabled On = Power-on password disabled |
| S6 | Off | Off = No function On = Clear NVRAM |
| S7 | Off | Reserved |
| S8 | Off | Reserved |
| S9 | Off | Reserved |
| S10 | Off | Reserved |

When the system maintenance switch position 6 is set to the On position, the system is prepared to erase all system configuration settings from both CMOS and NVRAM.

CAUTION: Clearing CMOS and/or NVRAM deletes configuration information. Be sure to properly configure the server or data loss could occur.

NMI jumper

The NMI jumper allows administrators to perform a memory dump before performing a hard reset. Crash dump analysis is an essential part of eliminating reliability problems, such as hangs or crashes in OSs, device

drivers, and applications. Many crashes can freeze a system, requiring you to do a hard reset. Resetting the system erases any information that would support root cause analysis.

Systems running Microsoft® Windows® experience a blue-screen trap when the OS crashes. When this happens, Microsoft® recommends that system administrators perform an NMI event by temporarily shorting the NMI header with a jumper. The NMI event enables a hung system to become responsive again.

Personality board components

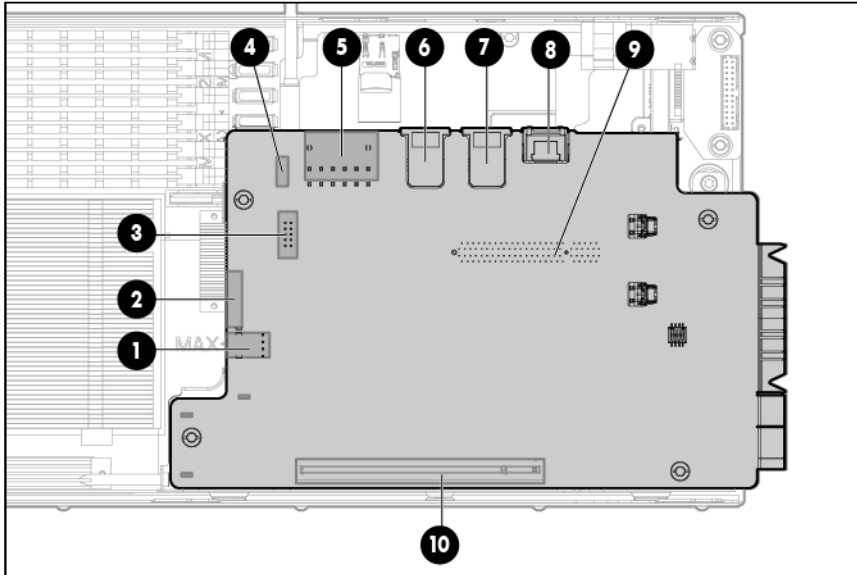

| Item | Description |
|------|---------------------------------|
| 1 | Drive power connector |
| 2 | RPS connector |
| 3 | Serial connector* |
| 4 | LED cable connector* |
| 5 | Power connector |
| 6 | NIC 2 connector |
| 7 | NIC 1 connector |
| 8 | iLO connector |
| 9 | x8 personality board connector |
| 10 | x16 personality board connector |

* This connector is underneath the board.

Cabling

Personality board cabling

To access cables underneath the personality board assembly, see "Personality board assembly (on page 37)."

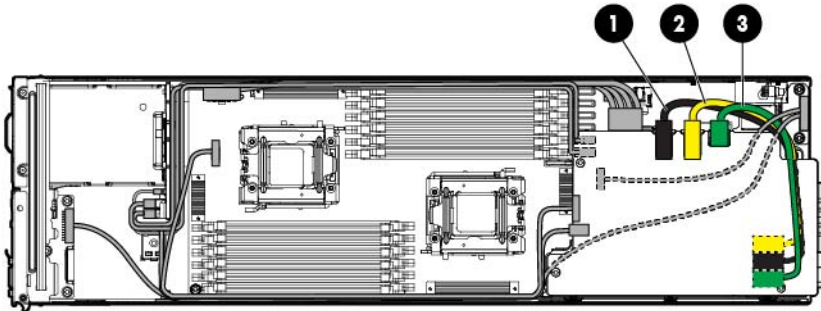

| Item | Description |
|------|--------------|
| 1 | NIC 2 (1 Gb) |
| 2 | NIC 1 (1 Gb) |
| 3 | iLO |

HDD data LED cabling

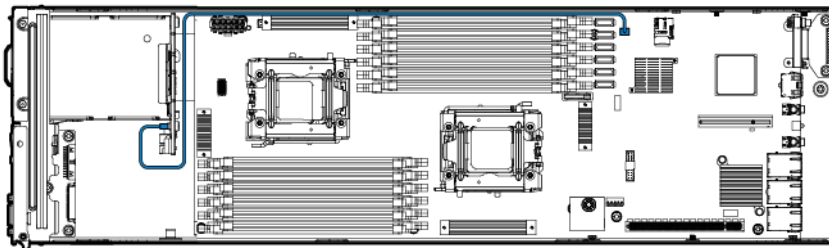

The HDD data LED cable routes underneath the SATA cables and power cable.

Connect and route the cables in the following order:

1. **HDD data LED cable (bottom)**
2. SATA cables
3. Power cable

SATA cabling

To access cables underneath the personality board assembly, see "Personality board assembly (on page 37)."

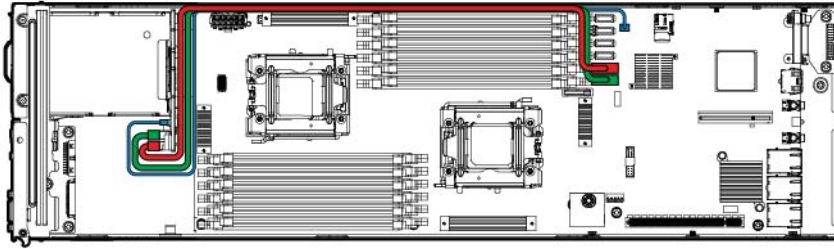

The SATA cables route over the HDD data LED cable and underneath the power cable.

Connect and route the cables in the following order:

1. HDD data LED cable (bottom)
2. **SATA cables**
3. Power cable

Internal power cabling

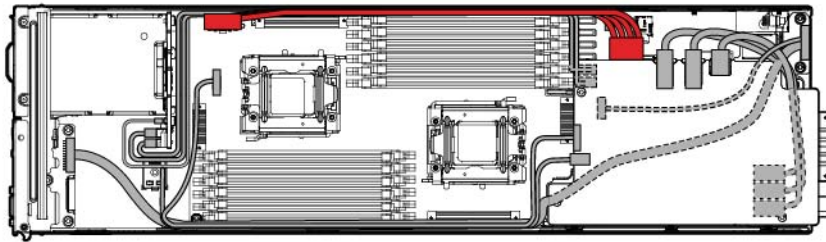

The power cable routes over the HDD LED cable and SATA cables.

Connect and route the cables in the following order:

1. HDD data LED cable (bottom)
2. SATA cables
3. **Power cable**

RPS cabling

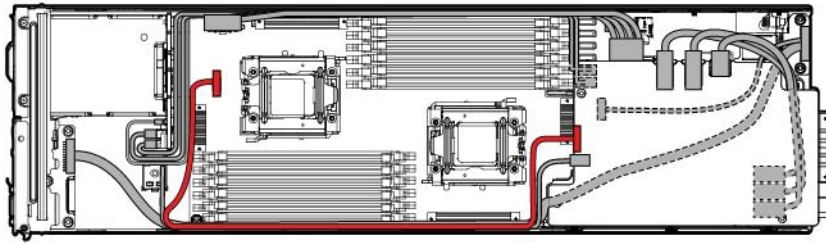

The RPS cable routes with the front LED cable underneath the SATA board power cable and USB/VGA cable.

Connect and route the cables in the following order:

1. **RPS cable and front LED cable (bottom)**
2. SATA power board cable
3. USB/VGA cable

Front I/O cabling

To access cables underneath the personality board assembly, see "Personality board assembly (on page 37)."

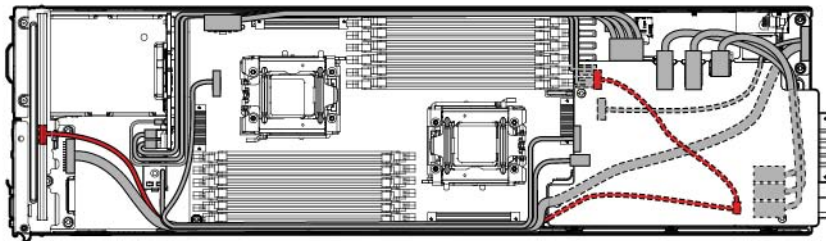

The front LED cable routes with the RPS cable underneath the SATA board power cable and the USB/VGA connector cable.

Connect and route the cables in the following order:

1. **RPS cable and front LED cable (bottom)**
2. SATA power board cable
3. USB/VGA cable

SATA board power cabling

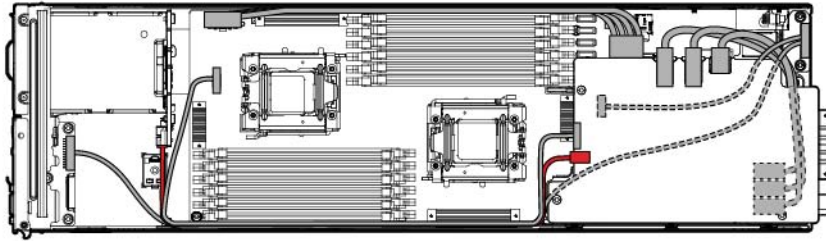

The SATA board power cable routes on top of the RPS cable and front LED cable, and underneath the USB/VGA cable. Secure the SATA board power cable in the plastic clip provided.

Connect and route the cables in the following order:

1. RPS cable and front LED cable (bottom)
2. **SATA power board cable, secured in the plastic clip**
3. USB/VGA cable

USB/VGA cabling

To access cables underneath the personality board assembly, see "Personality board assembly (on page 37)."

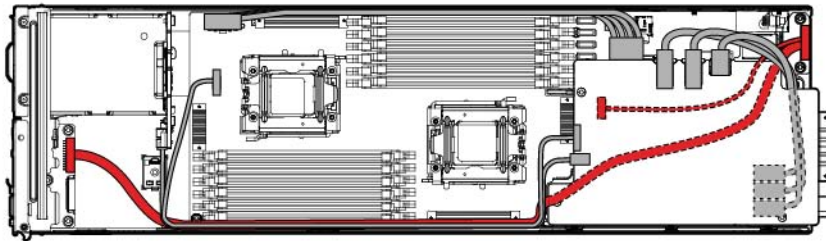

The USB/VGA cable routes on top of the SATA board power cable, RPS cable, and front LED cable.

Connect and route the cables in the following order:

1. RPS cable and front LED cable (bottom)
2. SATA power board cable
3. **USB/VGA cable**

Specifications

Environmental specifications

| Specification | Value |
|--|--------------------------------|
| Temperature range* | |
| Operating | 10°C to 35°C (50°F to 95°F) |
| Shipping | -40°C to 70°C (-40°F to 158°F) |
| Maximum wet bulb temperature | 28°C (82.4°F) |
| Relative humidity (noncondensing)** | |
| Operating | 10% to 90% |
| Nonoperating | 5% to 95% |

* All temperature ratings shown are for sea level. An altitude derating of 1°C per 300 m (1.8°F per 1,000 ft) to 3,048 m (10,000 ft) is applicable. No direct sunlight allowed.

** Storage maximum humidity of 95% is based on a maximum temperature of 45°C (113°F). Altitude maximum for storage corresponds to a pressure minimum of 70 kPa.

Hot-plug power supply calculations

For hot-plug power supply specifications and calculators to determine electrical and heat loading for the server, see the HP Power Advisor website (<http://www.hp.com/go/hppoweradvisor>).

Acronyms and abbreviations

CSR

Customer Self Repair

NMI

nonmaskable interrupt

RPS

redundant power supply

SUV

serial, USB, video

Documentation feedback

HP is committed to providing documentation that meets your needs. To help us improve the documentation, send any errors, suggestions, or comments to Documentation Feedback (<mailto:docsfeedback@hp.com>). Include the document title and part number, version number, or the URL when submitting your feedback.

Index

A

access panel 24

B

backplane board 35
batteries, replacing 47
battery 47
buttons 22, 52

C

cables 57
cabling 57, 58, 59, 60
cabling, front I/O 59
cabling, internal power 58
cabling, personality board 57
cabling, RPS 59
cabling, SATA 58
cabling, SATA board power 60
cabling, USB 60
cabling, VGA 60
Care Pack 51
cautions 25
chassis, installing server 23
chassis, removing server 23
components 15, 52
components, identification 15, 52, 54, 56
components, mechanical 15
components, personality board 56
components, system board 54, 55
connectors 52

D

diagnosing problems 49
diagnostic tools 50
diagnostics utility 50
DIMMs 28, 55
drive blank 26
drive LEDs 53
drive, replacing 26
drives 26, 53
drives, removing 26

E

electrostatic discharge 24
environmental requirements 61
environmental specifications 61

F

features 52
front I/O cabling 59
front LED cabling 59
front panel board 36
front panel components 52
front panel LEDs 52

H

heatsink 29
hot-plug power supply calculations 61
HP Insight Diagnostics 50
HP Insight Remote Support software 51

I

illustrated parts catalog 15
iLO (Integrated Lights-Out) 50
IML (Integrated Management Log) 50
Insight Diagnostics 50
installing the access panel 24
Integrated Lights-Out (iLO) 50
Integrated Management Log (IML) 50

L

LED cable 57
LEDs 53
LEDs, drive 53
LEDs, front panel 52, 53
LEDs, hard drive 53
LEDs, SAS hard drive 53
LEDs, troubleshooting 49

M

management tools 50
mechanical components 15

N

NMI header 55

P

personality board 37, 57
personality board cabling 57
personality board components 56
power cabling, internal 58
powering down 22
preparation procedures 22
problem diagnosis 49
processor 30

R

RBSU (ROM-Based Setup Utility) 50
removal and replacement procedures 22
removing the access panel 24
replacement procedures 22
required tools 22
ROM-Based Setup Utility (RBSU) 50
RPS cabling 59

S

safety considerations 24
safety information 24, 25
SAS drives 15, 53
SATA board power cabling 60
SATA cabling 58
server, installation 23
SFF backplane board 35
specifications 61
specifications, environmental 61
static electricity 24
SUV interface board 38
switch, system maintenance 55
symbols on equipment 25
system battery 47
system board components 54
system board replacement 39
system components 17, 52
system maintenance switch 55

T

technical support 5
temperature requirements 61
tools 22
Torx screwdriver 22
TPM (Trusted Platform Module) 47

troubleshooting 49
troubleshooting resources 49
Trusted Platform Module (TPM) 47

U

USB cabling 60
utilities 50
utilities, deployment 50

V

VGA cabling 60

W

warnings 25
weight 61

Free Manuals Download Website

<http://myh66.com>

<http://usermanuals.us>

<http://www.somanuals.com>

<http://www.4manuals.cc>

<http://www.manual-lib.com>

<http://www.404manual.com>

<http://www.luxmanual.com>

<http://aubethermostatmanual.com>

Golf course search by state

<http://golfingnear.com>

Email search by domain

<http://emailbydomain.com>

Auto manuals search

<http://auto.somanuals.com>

TV manuals search

<http://tv.somanuals.com>