

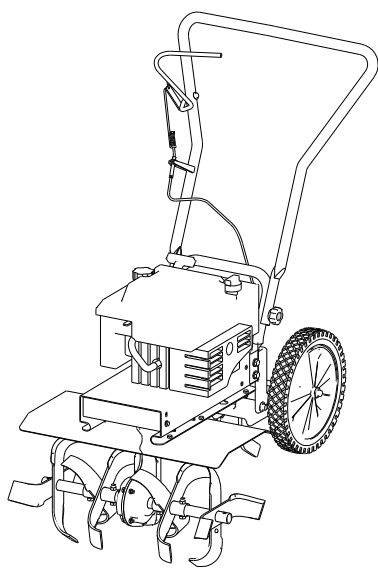

Operator's Manual
Original Operating Instructions
3365 Series
Front-Tine Tiller



Model 3365B
Briggs & Stratton
6.75 ft-lbs Gross Torque

Model 3365CE
Briggs & Stratton
6.75 ft-lbs Gross Torque

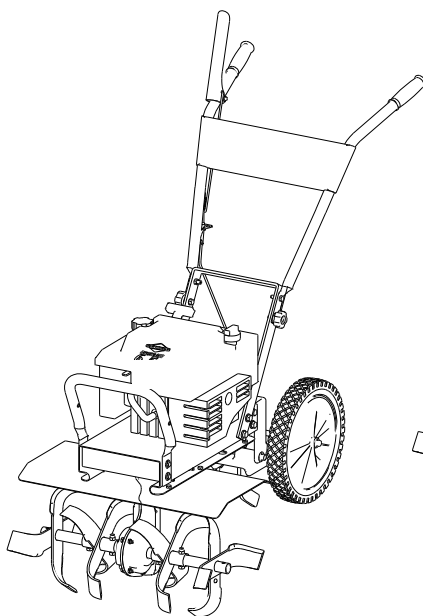

Model 3365PS
Briggs & Stratton
6.75 ft-lbs Gross Torque

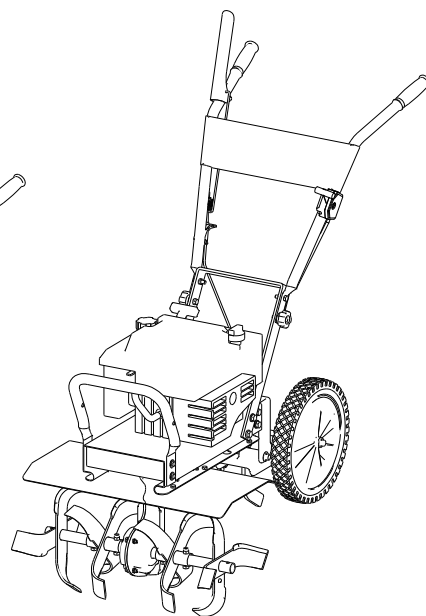

3365PSCE
Briggs & Stratton
8.5 ft-lbs Gross Torque

Get parts online at
www.getearthquake.com



OMFT
Rev. 06/12/12
© 2012 Ardisam, Inc.
All Rights Reserved.



INTRODUCTION

Congratulations on your investment in quality. Thank you for purchasing an Earthquake® Front Tine Tiller. We have worked to ensure that your tiller meets the highest standards for usability and durability. With proper care, your powerhead will provide many years of service.

Read this entire manual before installation and use. Earthquake® reserves the right to change, alter or improve the product and this document at any time without prior notice.

CONTENTS

Introduction 3
Warnings and Safety Precautions..... 4-6
Unpacking and Assembly 7
Features 8
Operation 10-11
Maintenance and Storage 12-15
Troubleshooting and Repair..... 16
Parts Breakdown 17-24
Warranty 25

FEDERAL EMISSION INFORMATION

Ardisam warrants to the retail purchaser, that this small, off-road engine was designed, built and equipped to conform at the time of initial sale to all applicable regulations of the U.S. Environmental Protection Agency (EPA) and those of the State of California (CARB).

REGISTRATION AND SERVICE

Record the model number and serial number in the space provided for easy reference when ordering parts or requesting technical support. Excluding emissions-related warranty items, the warranty is valid only if the completed registration is received by Earthquake® within 30 days of purchase. (SEE WARRANTY SECTION FOR MORE INFORMATION.) You can register your warranty online by visiting www.getearthquake.com, or by mailing it to: Earthquake®, 1160 Eighth Avenue, Cumberland, WI 54829. If you do not have a computer, call our customer service department to register your product.

OWNERSHIP RECORDS
Owner's Name:
Owner's Address:
City: State/Province: Zip Code/Postal Code:
Model Number: Serial Number:
Date of Purchase:
Notes:

This manual may contain information for several models. Read and keep this manual for future reference. This manual contains important information on SAFETY, ASSEMBLY, OPERATION, AND MAINTENANCE. The owner must be certain that all the product information is included with the unit. This information includes the MANUAL, the REPLACEMENT PARTS and the WARRANTIES. This information must be included to make sure state laws and other laws are followed. This manual should remain with the engine even if it is resold.

WARNINGS AND SAFETY PRECAUTIONS

OWNER'S RESPONSIBILITY

Accurate assembly and safe and effective use of the rototiller is the owner's responsibility.

- Read and follow all safety instructions.
- Carefully follow all assembly instructions.
- Maintain the tiller according to directions and schedule included in this Earthquake operator's manual.
- Ensure that anyone who uses the tiller is familiar with all controls and safety precautions.

SPECIAL MESSAGES

Your manual contains special messages to bring attention to potential safety concerns, machine damage as well as helpful operating and servicing information. Please read all the information carefully to avoid injury and machine damage.

NOTE: General information is given throughout the manual that may help the operator in the operation or service of the machine.

IMPORTANT SAFETY PRECAUTIONS

Please read this section carefully. Operate the tiller according to the safety instructions and recommendations outlined here and inserted throughout the text. Anyone who uses this tiller must read the instructions and be familiar with the controls. Your tiller is equipped with a safety device that enables you to stop the wheels and tines quickly in an emergency. Learn how the drive safety control lever operates and how to control the tiller at all times.



This symbol points out important safety instructions which if not followed could endanger your personal safety. Read and follow all instructions in this manual before attempting to operate this equipment.

- Do not allow children to operate this rototiller. Keep small children away from the area being tilled. Do not allow adults to operate the tiller without proper instruction.

PREPARATION

- Dress appropriately when operating the tiller. Always wear sturdy footwear. Never wear sandals, sneakers or open shoes, and never operate the tiller with bare feet. Do not wear loose clothing that might get caught in moving parts.
- Carefully inspect the area to be tilled and remove all foreign objects. Do not till above underground water lines, gas lines, electric cables, or pipes. Do not operate the tiller in soil with large rocks and foreign objects which can damage the equipment.
- Disengage all clutches and leave all control levers in the neutral position before starting the engine.
- Handle fuel with care; it is highly flammable.
 - a. Use an approved fuel container.
 - b. Never add fuel to a running engine or hot engine.

DANGER

DANGER INDICATES A SERIOUS INJURY OR FATALITY WILL RESULT IF THE SAFETY INSTRUCTIONS THAT FOLLOW THIS SIGNAL WORD ARE NOT OBEYED.

WARNING

WARNING INDICATES A SERIOUS INJURY OR FATALITY COULD RESULT IF THE SAFETY INSTRUCTIONS THAT FOLLOW THIS SIGNAL WORD ARE NOT OBEYED.

CAUTION

CAUTION INDICATES YOU CAN OR YOUR EQUIPMENT CAN BE HURT IF THE SAFETY INSTRUCTIONS THAT FOLLOW THIS SIGNAL WORD ARE NOT OBEYED.

IMPORTANT

IMPORTANT INDICATES HELPFUL INFORMATION FOR PROPER ASSEMBLY, OPERATION, OR MAINTENANCE OF YOUR EQUIPMENT.

WARNING

YOU MUST READ, UNDERSTAND AND COMPLY WITH ALL SAFETY AND OPERATING INSTRUCTIONS IN THIS MANUAL BEFORE ATTEMPTING TO SET UP AND OPERATE YOUR ROTOTILLER.

FAILURE TO COMPLY WITH ALL SAFETY AND OPERATING INSTRUCTIONS CAN RESULT IN LOSS OF MACHINE CONTROL, SERIOUS PERSONAL INJURY TO YOU AND/OR BYSTANDERS, AND RISK OF EQUIPMENT AND PROPERTY DAMAGE. THE TRIANGLE IN THE TEXT SIGNIFIES IMPORTANT CAUTIONS OR WARNINGS WHICH MUST BE FOLLOWED.

CALIFORNIA PROPOSITION 65 WARNING
ENGINE EXHAUST FROM THIS PRODUCT CONTAINS CHEMICALS KNOWN TO THE STATE OF CALIFORNIA TO CAUSE CANCER, BIRTH DEFECTS, OR OTHER REPRODUCTIVE HARM.

- c. Fill fuel tank outdoors with extreme care. Never fill fuel tank indoors.
- d. Replace gasoline cap securely and clean up spilled fuel before restarting.
- Never attempt to make any adjustments while the engine is running.

OPERATION

- Do not operate the tiller under the influence of alcohol or drugs.
- Never operate the tiller without guards, covers, and hoods in place.
- Keep hands, feet, and clothing away from rotating parts. Keep clear of tiller tines at all times.
- Tines rotate when tiller is engaged; tines rotate when the drive safety control lever is pulled down. Releasing the drive safety control lever to *neutral* stops the tines.
- Use extreme caution when operating on or crossing gravel drives, walks, or roads. Stay alert for hidden hazards or traffic.
- After striking a foreign object, stop the engine, remove the wire from the spark plug, thoroughly inspect the tiller for any damage, and repair the damage before restarting and operating the tiller.
- **IF VEGETATION CLOGS THE TINES, STOP THE ENGINE AND DISCONNECT THE SPARK PLUG WIRE** before removing vegetation by hand.
- Engine muffler will be hot from operation. Do not touch it with bare skin or a severe burn may result.
- If the unit should start to vibrate abnormally, stop the engine and check immediately for the cause. Vibration is generally a warning of trouble.
- Do not run the engine indoors; exhaust fumes are deadly.
- Do not overload the machine capacity by attempting to till too deep at too fast of a rate.
- Never allow bystanders near the unit.
- Never operate the tiller without good visibility or light.
- Be careful when tilling in hard ground. The tines may catch in the ground and propel the tiller forward. If this occurs, let go of the handlebars and do not restrain the machine.
- Take all possible precautions when leaving the machine unattended. Disengage all control levers, stop the engine, wait for all moving parts to stop, and make certain guards and shields are in place.
- When leaving the operating position for any reason:
 - shut off the engine.
 - wait for all moving parts to stop.

IMPORTANT

THE RIGHT AND LEFT SIDES OF YOUR ROTOTILLER ARE DETERMINED FROM THE OPERATING POSITION AS YOU FACE THE DIRECTION OF FORWARD TRAVEL.

ENGINE IS SHIPPED FROM FACTORY WITHOUT OIL. YOU MUST ADD ENGINE OIL BEFORE STARTING ENGINE.

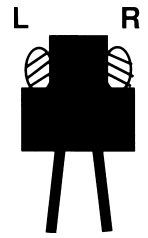

IMPORTANT

THIS IS A MOTORIZED ROTARY TILLER THAT WORKS THE SOIL BY MEANS OF ROTATING TINES. IT IS PEDESTRIAN CONTROLLED, BUT NOT SELF-PROPELLED, WITH A GASOLINE-FUELED INTERNAL COMBUSTION ENGINE TO POWER THE TINES. IT SHALL NOT BE USED FOR ANY OTHER PURPOSE.

MAINTENANCE AND STORAGE

- Keep machine, attachments and accessories in safe working condition.
- Check shear bolts, engine mounting bolts and other bolts at frequent intervals for proper tightness to be sure the equipment is in safe working condition.
- To prevent accidental starting, always disconnect and secure the spark plug wire from the spark plug before performing tiller maintenance.
- Never run the engine indoors. Exhaust fumes are deadly.
- Always allow muffler to cool before filling the fuel tank.
- Never store equipment with gasoline in the tank inside a closed building where fumes may reach an open flame or spark. Allow the engine to cool before storing in any building.
- Always refer to the operator's guide instructions for important details if the tiller is to be stored for an extended period.

INTENDED USE/FORESEEABLE MISUSE

IMPORTANT! This is a motorized rotary tiller that works the soil by means of rotating tines. It is pedestrian controlled, but not self-propelled, with a gasoline-fueled internal combustion engine to power the tines. It shall not be used for any other purpose.

SAFETY DECALS

This rototiller unit has been designed and manufactured to provide you with the safety and reliability you would expect from an industry leader in outdoor power equipment manufacturing.

Although reading this manual and the safety instructions it contains will provide you with the necessary basic knowledge to operate this equipment safely and effectively, we have placed several safety labels on the tiller to remind you of this important information while you are operating the unit.

These important safety labels are illustrated below, and are shown here to help familiarize you with the location and content of the safety messages you will see as you perform normal tilling operations. Please review these labels now. If you have any questions regarding their meaning or how to comply with these instructions, reread the complete safety instruction text on the preceding pages, or contact your local dealer.

Should any of the safety labels become unreadable because of being worn, faded, or otherwise damaged during the use of your tiller, please use the part number information provided to order a replacement label from your local authorized dealer.

The safety labels are easily applied and will act as a constant visual reminder to you and others who may use the equipment. Follow the safety instructions necessary for safe, effective operation of your rototiller.

DANGER

AVOID INJURY FROM ROTATING TINES!
 Keep hands, feet and clothing away.

- Tines rotate when tiller is engaged.
- Tines rotate when drive control lever is pulled back.
- Releasing the drive control lever to neutral stops the tines.

OPERATION

REFER TO OPERATOR'S MANUAL FOR DETAILED OPERATING INSTRUCTIONS

TO START:

1. Release drive control lever to neutral position.
2. Pull transport wheels back to unfold machine.
3. Push primer.
5. Move throttle control lever to fast position.
6. Pull starter rope.

LBL3100C

Part No. LBL3100C
TINES DANGER/OPERATION
Hood Decal

ARDISAM, INC.

1160 8th Avenue | Cumberland, WI 54829 | USA

Serial No.
LBLINFO3365PSCE

Earthquake 3365PSCE Front Tine Tiller
 Year: **2010** Mass: **48 kg**
 Max. Eng. Operating Speed: **3600 rpm**
 Nominal Power Rating: **3.36 kW**

Part No. LBLINFO3365PSCE
Name Plate
Tine Shield Decal

ARDISAM, INC.

1160 8th Avenue | Cumberland, WI 54829 | USA

Serial No.
LBLINFO3365CE

Earthquake 3365CE Front Tine Tiller
 Year: **2010** Mass: **47 kg**
 Max. Eng. Operating Speed: **3600 rpm**
 Nominal Power Rating: **2.61 kW**

Part No. LBLINFO3365CE
Name Plate
Tine Shield Decal

WARNING

AVOID SERIOUS INJURY OR DEATH

- Read operator's manual(s).
- Know the location and function of all controls.
- Keep all shields and guards in place and working while running.
- Never operate tiller when children are around.
- Dress appropriately --- wear sturdy footwear.
- Carefully inspect area to be tilled --- remove large rocks and other foreign objects.
- Do NOT till above underground electric, water, gas, or other utility lines and pipes.
- STOP THE ENGINE AND DISCONNECT THE SPARK PLUG WIRE before removing debris or servicing unit.
- When leaving the operating position for any reason:
 - shut off the engine.
 - wait for all moving parts to stop.

LBL821B

Part No. LBL821B
HOOD WARNING
Hood Decal

CLUTCH ENGAGE

PLACE FREE HAND ON HANDLEBAR WHEN STARTING

ENGAGE

LBL3100D

Part No. LBL3100D
CLUTCH ENGAGE
Handlebar Decal

WARNING!

DO NOT START ENGINE UNLESS BELT COVER IS ATTACHED. KEEP HANDS, FEET, AND CLOTHING AWAY FROM MOVING BELTS AND PULLEYS. FAILURE TO COMPLY COULD RESULT IN INJURY. SEE OWNER'S MANUAL FOR FULL SAFETY INSTRUCTIONS.

LBL516C

Part No. LBL516C
WARNING
Belt Cover Decal

WARNING

PINCH POINT
KEEP HANDS
AND FINGERS AWAY

LBL3100H

Part No. LBL3100H
WARNING
Pivot Mount Decal

LWA

98

dB

Part No. LBLCNOISE98
Decibel Level Decal

LWA

95

dB

Part No. LBLCNOISE95
Decibel Level Decal

UNPACKING AND ASSEMBLY

UNPACK TILLER AND ASSEMBLE

1. Open top of carton and remove handlebar assembly.
2. Find parts packet. Parts packet for 3365B/3365CE contains:

- 6- 5/16-18 x 1-3/4" bolts
- 6- 5/16" spring lockwashers
- 2- hand knobs
- 4- locknuts
- 2- 1/2" push nuts
- 1- detent pin

Parts packet for 3365PS/3365PSCE contains:

- 2- 3/8-16 x 1" bolts
- 2- 3/8-16 biway locknuts
- 2- 5/16-18 x 1" bolts
- 4- 5/16-18 x 1-3/4" bolts
- 6- 5/16" spring lockwashers
- 2- hand knobs
- 4- 5/16" locknuts
- 2- 1/2" push nuts
- 1- detent pin

3. Cut open end of carton and remove machine:
 - a. Install wheels on each end of axle; tap on push nuts with a hammer.
 - b. Assemble tines to unit, inside tines first. Sharp edge of tine will be away from operator at top, or face down at front of machine.
 - c. Outside tines have two positions- wide 21" and narrow 16".
For narrow width, assemble with short side of tine holder pipe towards center of machine.
 - d. For wide width, move the left tine to the right side and right tine to the left side. Assemble with the long half of tine pipe towards machine.
 - e. Slide the top handle of handlebar over the lower loop. Put 5/16-18 x 1-3/4" bolts through both holes from inside out; put on 5/16" spring lockwashers and tighten with hand knobs. Model 3365PS will use 3/8-16 x 1" bolts with nuts and 5/16-18 x 1" bolts with hand knobs. See the parts breakdowns for more information.
 - f. Check upper and lower jam nuts for tightness. See "Controls" section for belt tension adjustment instructions.
 - g. Add and check engine oil.

INSTALL DEPTH REGULATOR LEVER

1. Install the depth regulator lever through hole in bracket from the bottom up with curve to rear of unit and secure with detent pin.

FILL ENGINE CRANKCASE

1. Add oil according to engine manual. **Do not overfill.** Use a clean, high quality detergent oil. Use no special additives with recommended oils. **Do not mix oil with gasoline.** Oil level must be full. Check the oil level by checking the engine's oil dipstick if provided, or by removing oil fill plug. Oil level should be up to the bottom of the fill plug opening.
2. Always check oil level before starting engine. Refer to engine manual for capacity and type of oil to use.

IMPORTANT

THE RIGHT AND LEFT SIDES OF YOUR ROTOTILLER ARE DETERMINED FROM THE OPERATING POSITION AS YOU FACE THE DIRECTION OF FORWARD TRAVEL.

ENGINE IS SHIPPED FROM FACTORY WITHOUT OIL. YOU MUST ADD ENGINE OIL BEFORE STARTING ENGINE.

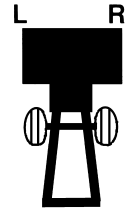

CAUTION

DO NOT TRY TO LIFT THE ROTOTILLER FROM THE CARTON.

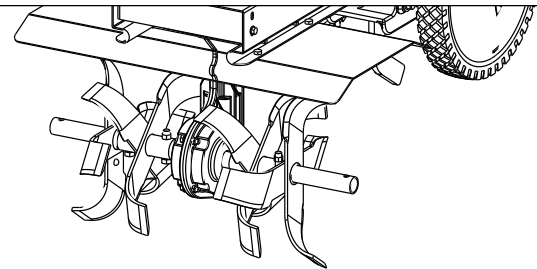

NARROW TINE WIDTH

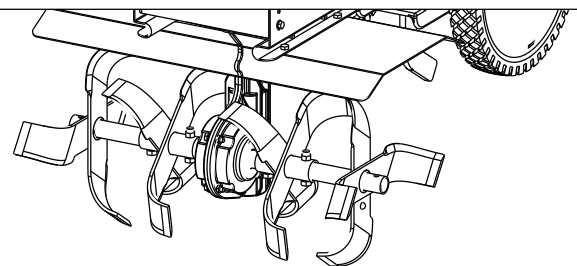

WIDE TINE WIDTH

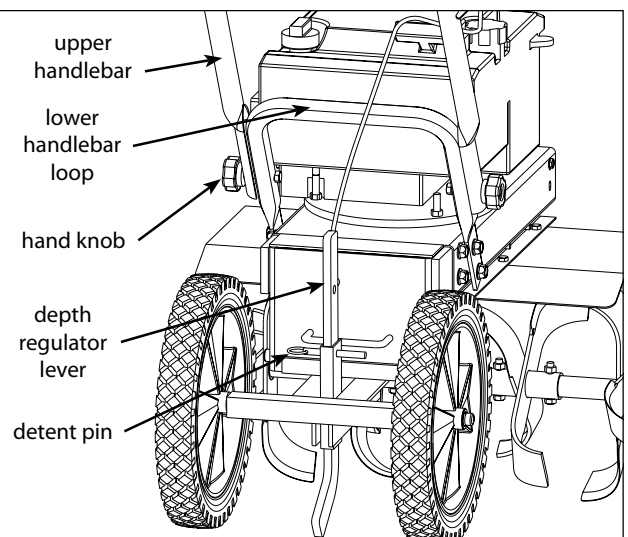

FEATURES (3365B/3365CE)

The advantage of the **EARTHQUAKE® gear drive front tine rototiller** over other front tine tillers is the exclusive unfolding and flexible drag bar. This gives the tiller its stability and versatility. For easy transport, fold the wheels under the engine. During operation, the wheels unfold back and the drag bar folds down. The long length between the tines and the drag bar make this the most comfortable front tine tiller on the market.

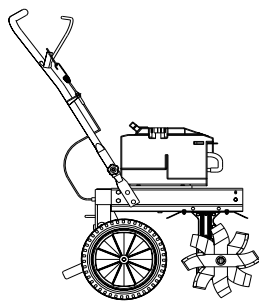
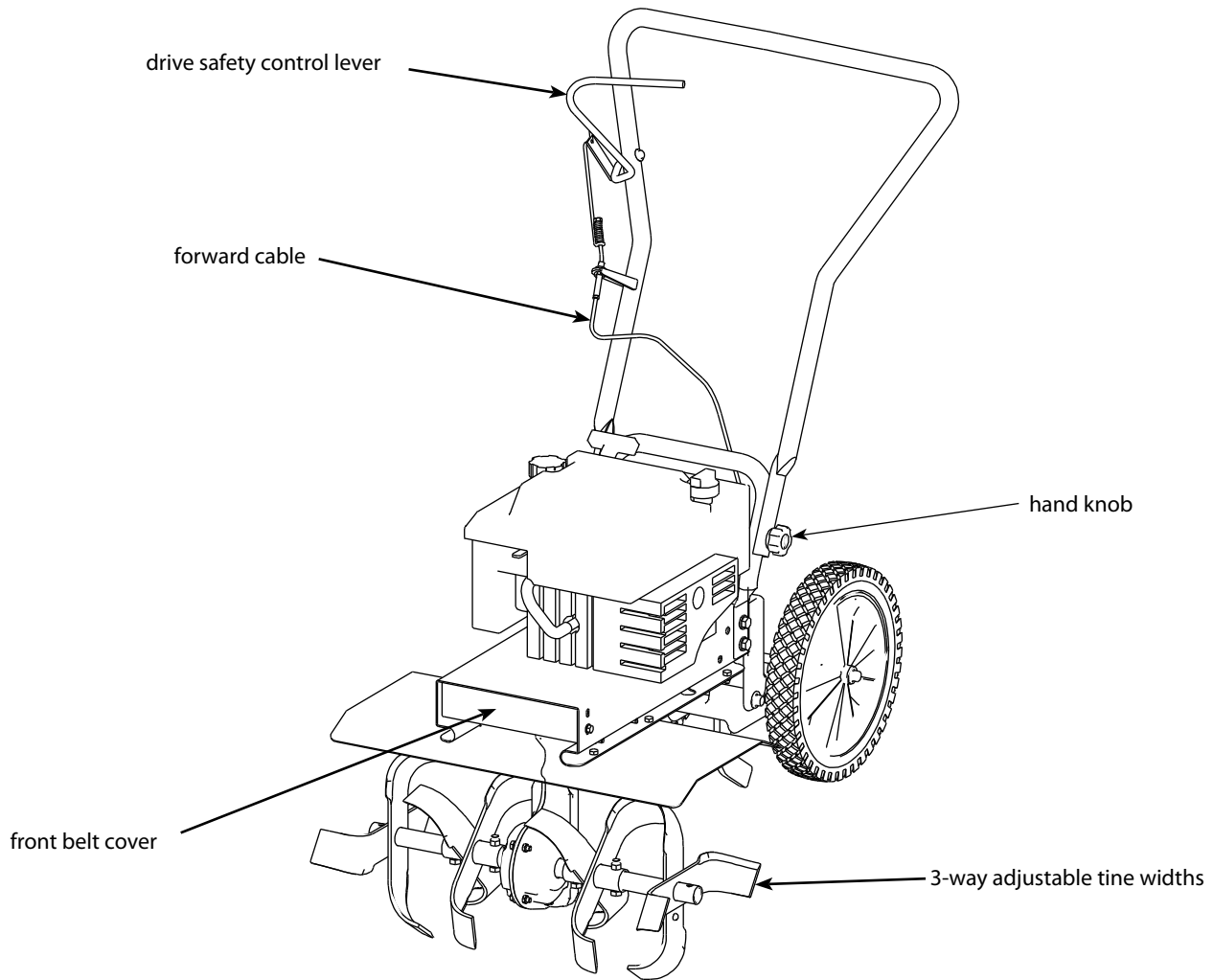

Transport Position

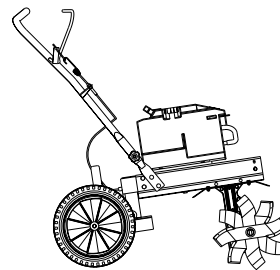

Operating Position

CONTROLS

DRIVE SAFETY CONTROL LEVER

Engages tines into forward; releasing returns machine to neutral.

Pulling down on the drive safety control lever engages the tines. Releasing the drive safety control lever disengages the tines to a neutral position.

BELT TENSION ADJUSTMENT

Proper belt tension is critical to good performance. After 30 minutes of operation, all cables may have to be adjusted due to initial stretch. Thereafter, check tension after every two hours of operation.

To increase belt tension:

1. Loosen upper jam nut. Turn nut up cable in 1/8" increments.
2. Tighten lower jam nut.
3. Check adjustment.

This procedure can be repeated until conduit adjustment bolts have no more adjustment left. If no more adjustment can be made, belt may have to be replaced.

DEPTH REGULATOR LEVER

Tilling depth is controlled by the height of the depth regulator lever.

To adjust tilling depth:

1. Remove detent pin.
2. Raise the depth regulator lever to position tines at chosen tilling depth.
3. Align hole in depth regulator lever with hole in depth regulator bracket and replace detent pin.

CAUTION

THIS INFORMATION IS PROVIDED HERE ONLY TO INTRODUCE THE CONTROLS. DO NOT START THE ENGINE AT THIS TIME. STARTING AND OPERATING INSTRUCTIONS ARE GIVEN ON PAGE 10. PLEASE READ THIS SECTION AND ALL OPERATING AND SAFETY INSTRUCTIONS BEFORE STARTING YOUR TILLER.

- AS A SAFETY PRECAUTION, THE DRIVE SAFETY CONTROL LEVER WILL NOT LOCK IN THE FORWARD POSITION.
- TO STOP THE WHEELS AND TINES AT ANYTIME, RELEASE THE DRIVE SAFETY CONTROL LEVER.

WARNING

ENGINE SHOULD BE OFF BEFORE ADJUSTING ANY CONTROLS. DO NOT ADJUST TILLING DEPTH UNLESS DRIVE SAFETY CONTROL LEVER IS RELEASED TO THE NEUTRAL POSITION.

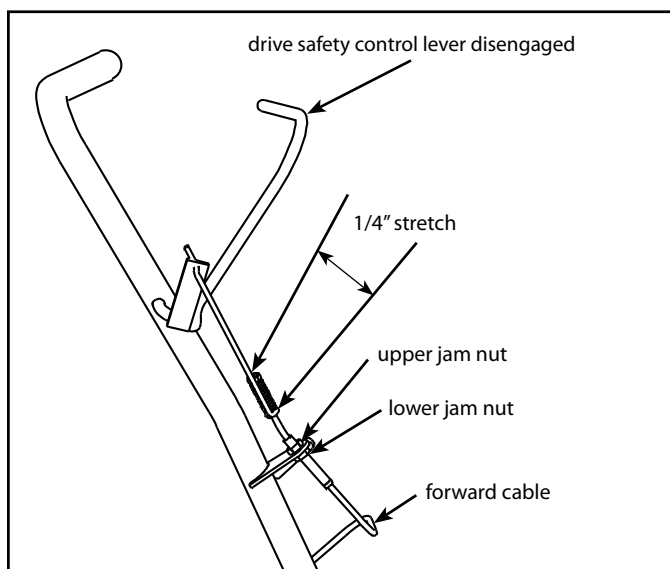
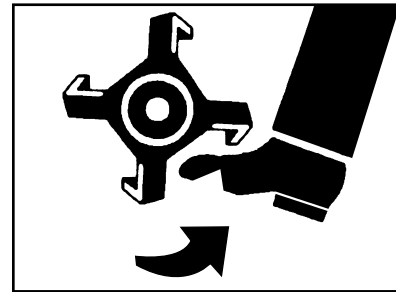

Models 3365B and 3365CE handlebar

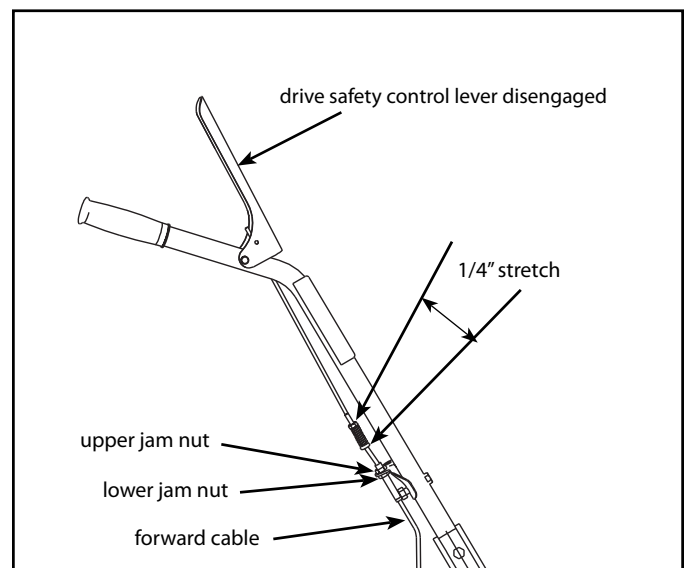

Models 3365PS and 3365PSC handlebar

OPERATION

PRE-START INSPECTION

1. Make sure all safety guards are in place and all nuts and bolts are secure.
2. Check oil level in engine crankcase. See your engine manual for procedure and specifications.
3. Inspect air cleaner for cleanliness. See your engine manual for procedure.
4. Check the fuel supply. Fill the fuel tank no closer than one inch from top of tank to provide space for expansion. See your engine manual for fuel recommendations.
5. Be sure spark plug wire is attached and spark plug is tightened securely.
6. Check position of wheels.
7. Check depth regulator lever position.
8. Examine underneath and around engine for signs of oil or fuel leaks.
9. Inspect fuel hoses for tightness and fuel seepage.
10. Look for signs of engine damage.
11. Remove excessive debris from muffler area and recoil starter.
12. Turn fuel shutoff valve to the ON position if engine is equipped with one. It's located between tank and carburetor.

START-UP

For models 3365B, 3365CE, and 3365PS only.

The controls required to start and run the rototiller are located on the engine and are marked CHOKE and THROTTLE.

A more detailed description of engine operation and all related precautions and procedures can be found in the engine manufacturer's manual that accompanies each tiller.

COLD STARTS

1. Move choke lever to FULL choke position.
2. Move throttle lever to START.
3. Pull starting rope out slowly one time and allow to return normally.
4. Pull starting rope out rapidly and allow rope to return normally.
5. When engine starts, gradually move choke lever to NO CHOKE position and increase throttle speed.

RESTARTING A WARM ENGINE

Restarting an engine that is already warm from previous running does not normally require the use of the choke.

1. Move throttle lever to START position.
2. Pull starting rope out rapidly until engine starts. Allow rope to return normally. Repeat until engine starts.
3. Adjust throttle speed to HIGH for best tiller action.

IMPORTANT

ENGINE IS SHIPPED FROM FACTORY WITHOUT OIL. YOU MUST ADD ENGINE OIL BEFORE STARTING ENGINE.

PRACTICE OPERATING THE CONTROLS AND TILLER WITH TINES OUT OF GROUND BEFORE BEGINNING TO TILL. IT IS IMPORTANT THAT YOU KNOW HOW TO USE THE TILLER PROPERLY, KEEP CONTROL AT ALL TIMES, STOP THE TINES AND WHEELS FROM TURNING, AND STOP THE ENGINE IF NECESSARY. IF YOU DO NOT KNOW HOW TO DO THESE THINGS, READ THE CONTROLS AND SAFETY SECTIONS BEFORE PROCEEDING.

CAUTION

PLEASE DO NOT START YOUR TILLER UNTIL YOU HAVE READ THE MANUAL THAT CAME WITH YOUR ENGINE AND THE SECTIONS IN THIS MANUAL TITLED "CONTROLS AND SAFETY." ONCE YOU HAVE READ THESE, FOLLOW THE APPROPRIATE STEPS TO START YOUR TILLER. ALWAYS PERFORM THIS PRE-START CHECKLIST BEFORE STARTING THE ENGINE.

WARNING

GASOLINE IS HIGHLY FLAMMABLE AND MUST BE HANDLED WITH CARE. NEVER FILL THE TANK WHEN THE ENGINE IS HOT OR RUNNING. ALWAYS MOVE OUTDOORS TO FILL THE TANK.

TEMPERATURE OF MUFFLER AND NEARBY AREAS MAY EXCEED 150° F. AVOID THESE AREAS.

DO NOT MOVE CHOKE CONTROL TO CHOKE TO STOP ENGINE. BACKFIRE OR ENGINE DAMAGE MAY OCCUR.

TO STOP THE ENGINE AT ANY TIME, MOVE THROTTLE CONTROL TO THE OFF POSITION. TO STOP TINES AT ANY TIME, RELEASE DRIVE SAFETY CONTROL LEVER TO THE NEUTRAL POSITION.

ALWAYS RELEASE DRIVE SAFETY CONTROL LEVER TO THE NEUTRAL POSITION BEFORE ADJUSTING THE DEPTH OF THE REGULATOR LEVER.

For model 3365PSCE only.

The controls required to start and run the rototiller are located on the handle.

A more detailed description of engine operation and all related precautions and procedures can be found in the engine manufacturer's manual that accompanies each tiller.

COLD STARTS

1. Move the throttle control to the FAST position.
2. Pull starting rope out slowly one time and allow to return normally.
3. Pull starting rope out rapidly and allow rope to return normally.
4. Operate engine in the FAST position.

RESTARTING A WARM ENGINE

Restarting an engine that is already warm from previous running does not normally require use of the choke.

1. Move throttle lever to FAST position.
2. Pull starting rope out rapidly until engine starts. Allow rope to return normally. Repeat until engine starts.
3. Adjust throttle speed to FAST for best tiller action.

OPERATING SPEED

For normal tilling, set the throttle lever to FAST.

SHUTTING DOWN

For models 3365B, 3365CE and 3365PS only.

To stop the engine at any time, move the throttle control to the OFF position. To stop wheels and tines at any time, release the drive safety control to the NEUTRAL position.

ADDITIONAL SAFETY INFORMATION (CE UNITS ONLY)

The 3365CE rototiller unit has been tested and verified to be within the acceptable level of noise range for CE compliance at 95dB L_{WA}.

For the health and safety of the consumer it is recommended that this product be used for no more than 2 consecutive hours in any given 12 hour period.

Sound and Vibration Levels

Model	2006/42/EC Operator Ear L _{PA} (dBA)	2006/42/EC Sound Power Level L _{WA} (dBA)	2006/42/EC Hand/Arm Vibration Max m/s ²	2006/42/EC Vibration Time Limit
3365PSCE Front Tine Tiller	86	98	3.3	EAV= 4 h. 35 min. ELV= 18 h. 22 mins.

Sound levels test in accordance with ISO3744 and ISO 11201 - Grade 2 (Engineering) Method. Readings taken with engine at full throttle. EAV=Exposure Action Value; ELV=Exposure Limit Value

WARNING

EXTREME CAUTION MUST BE TAKEN IN SELECTING TILLING DEPTH. IF YOU ATTEMPT TO TILL TOO DEEPLY FOR SOIL CONDITIONS—THAT IS, WITH THE DRAG STAKE IN TOO HIGH OF A POSITION—LOSS OF CONTROL COULD RESULT.

IF REMOVING MATERIAL FROM THE TINES BY HAND, STOP THE ENGINE AND REMOVE SPARK PLUG WIRE FIRST.

DANGER

ENGINE AND SURROUNDING PARTS BECOME EXTREMELY HOT DURING NORMAL USE AND WILL CAUSE SERIOUS BURN INJURIES IF TOUCHED BEFORE THE ENGINE HAS COOLED.

ALLOW ENGINE TO COOL COMPLETELY BEFORE TOUCHING THESE HOT SURFACES.

ALWAYS KEEP HANDS AND FEET CLEAR OF ROTATING MACHINE PARTS.

For model 3365PSCE only.

To shut the engine off, push the throttle control lever all the way forward. Turn the fuel shutoff valve to the CLOSED position.

TILLING

1. Adjust the depth regulator lever to desired tilling depth.

NOTE: Raise depth regulator lever up one hole at a time, testing tiller operation after each raise. Raising depth regulator lever too high can result in loss of control of tiller!

2. Move the throttle control to FAST.
3. Place the tiller in motion by pushing down on the drive safety control lever; this will engage the tines.

MAINTENANCE AND STORAGE

MAINTENANCE SCHEDULE

Your rototiller has been designed and produced by the industry's leading manufacturer of outdoor power equipment to provide you with years of reliable operation.

Keeping your tiller in top running condition will prolong its life, and help you obtain optimum performance.

Please read this normal care schedule, and note the recommended care operating intervals to extend the life of your unit.

Maintenance Operation	Page	Before Each Use	50 hours or Every Season
Check belt tension	13	X	
Change forward belt	13		X
Engine maintenance	14	X	X
Check oil level/change oil	14	X	2
Clean tine axle shaft	14	X	
Lubrication	14		X
Check throttle control adjustment	-		1

EM = See engine manual

1 Adjust throttle control after first three hours of operation or if engine is hard to start or run-on occurs.

2 Change oil after the first five to eight hours of use, then after every 50 hours or every season. Change oil every 25 hours when operating under heavy load or in high temperatures.

SERVICING THE ROTOTILLER

The following information will help you make the necessary checks and perform the procedures required to follow the normal care recommendations made for your rototiller unit.

If you prefer, your local authorized dealer can make these checks and perform the required procedures for you.

Important: Use only approved Ardisam spare parts

WARNING

To prevent accidental starting:

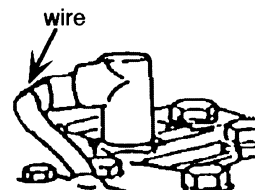

Engine must be turned off and cool, and spark plug wire must be removed and secured from spark plug before checking and adjusting engine or equipment.

CHECK BELT TENSION

Belt tension may decrease over time. It must be adjusted within the first half hour of operation and checked after every two hours of operation. Proper adjustment will assure long belt life. Too much or too little belt tension will cause premature belt failure. To check and adjust the forward belt tension:

1. Turn off engine. Engine must be cool.
2. Remove spark plug wire from spark plug and secure.
3. With drive safety control lever in the NEUTRAL position, measure length of spring when in its relaxed state.
4. Pull down on drive safety control lever and measure length of spring when compressed. Ideal length would be 1/4" shorter.

CHANGE FORWARD BELT

1. Turn off engine. Engine must be cool.
2. Remove spark plug wire from spark plug and secure.
3. Remove front belt cover.
 - Remove the belt from the engine pulley:
 - Gently pull the engine recoil rope to rotate the pulley.
 - With the pulley turning, force the belt out of the V-groove.
 - Slide the belt free of the engine pulley.
 - Pull the belt down and out of the way.
 - Push the belt forward and out front of machine.
 - Install new belt:
 - Place belt in transmission pulley groove.
 - Gently pull the engine recoil rope to rotate the pulley while forcing the belt into the V-groove.
4. Replace front belt cover.
5. Attach spark plug wire.

WARNING

CHECK FORWARD BELT TENSION REGULARLY. TOO MUCH OR TOO LITTLE TENSION WILL CAUSE PREMATURE BELT FAILURE.

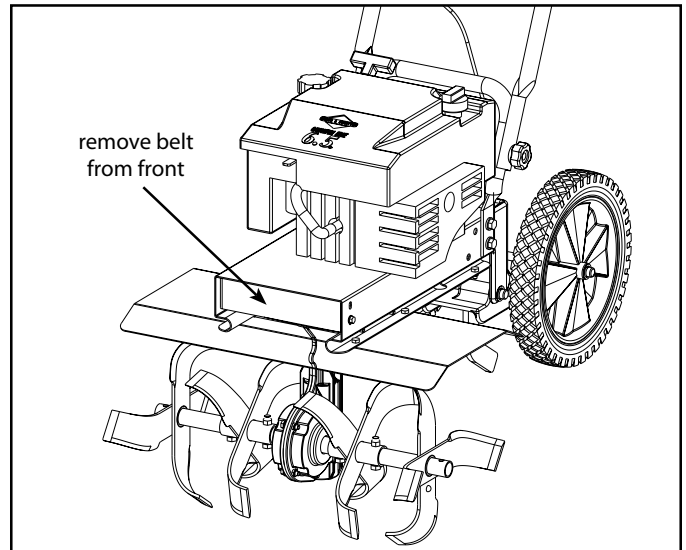

BELT REPLACEMENT PART #:

3370 (forward)

ENGINE MAINTENANCE

Refer to the engine manual included in your parts packet for information on engine maintenance. Your engine manual provides detailed information and a maintenance schedule for performing the following tasks:

1. Check oil level before each use or after every eight hours of operation.
2. Change oil after first five to eight hours of operation. Change oil while engine is warm. Refill with new oil of recommended grade.
4. Check spark plug yearly or every 100 hours of operation.
5. Service air cleaner.
6. Keep engine and parts clean.
7. Check engine and equipment often for loose nuts and bolts; keep these items tightened.

CHECK OR FILL ENGINE CRANKCASE

1. Add oil according to engine manual. **Do not overfill.** Use a clean, high-quality detergent oil. Use no special additives with recommended oils. **Do not mix oil with gasoline.** Oil level must be full. Check the oil level by checking the engine's oil dipstick if provided, or by removing oil fill plug. Oil level should be up to the bottom of the fill plug opening on most engines.
2. Always check oil level before starting engine. Refer to engine manual for capacity and type of oil to use.

CLEAN TINE AXLE SHAFT

1. Turn off engine. Engine must be cool.
2. Remove spark plug wire and secure from spark plug.
3. Remove all vegetation, string, wire, and other material that may have accumulated on the axle between the inside set of tines and the seal on the transmission housing.
4. Replace spark plug wire.

LUBRICATION

Proper lubrication of moving mechanical parts is critical for proper care and maintenance. Oil the moving parts using a 30-weight oil.

IMPORTANT

ENGINE IS SHIPPED FROM FACTORY WITHOUT OIL. YOU MUST ADD ENGINE OIL BEFORE STARTING ENGINE.

ENGINE CAN OVERHEAT AND BECOME DAMAGED IF DEBRIS BLOCKS THE COOLING SYSTEM OR ROTATING SCREEN.

NEVER RUN ENGINE WITHOUT COMPLETE AIR CLEANER INSTALLED ON ENGINE.



CAUTION

DO NOT OPERATE TILLER BEFORE READING THE ENGINE MANUAL PROVIDED IN THE PARTS PACKET.



WARNING

TEMPERATURE OF MUFFLER AND NEARBY AREAS MAY EXCEED 150° F. AVOID THESE AREAS.

STORAGE

PREPARE FOR STORAGE

Follow the steps below to prepare your tiller for storage. Read your engine manual for detailed instructions on preparing the engine for storage.

1. Protect wheels and axles from rust:
 - Coat the axles lightly with axle grease.
2. Drain fuel system completely following engine manufacturer's instructions or add fuel stabilizer to prevent fuel from gumming up during extended storage period.
3. While engine is still warm, drain the oil from the engine. Refill with fresh oil of the recommended grade.
4. Clean external surfaces, engine and cooling fan.
5. Remove spark plug; pour one ounce of SAE 30 oil into spark plug hole.
6. Plug hole and pull starter cord slowly to distribute oil evenly in cylinder head area.
7. Reinstall spark plug.
8. Transport unit to a suitable storage location. If you have chosen to use a fuel stabilizer and have not drained the fuel system, follow all safety instructions storage precautions in this manual to prevent the possibility of fire from the ignition of gasoline fumes. Remember, gasoline fumes can travel to distant sources of ignition and ignite, causing risk of explosion and fire.
9. If there is any possibility of unauthorized use or tampering, remove the spark plug and store it in a safe place before storing the rototiller unit. Be sure to plug the spark plug hole to prevent foreign material from entering.

WARNING

DO NOT STORE TILLER IN AN UNVENTILATED AREA WHERE FUEL FUMES MAY REACH FLAME, SPARKS, PILOT LIGHTS OR AN IGNITED OBJECT. DRAIN FUEL OUTDOORS AWAY FROM ANY IGNITION SOURCES. USE ONLY APPROVED FUEL CONTAINERS.

TROUBLESHOOTING AND REPAIR

TROUBLESHOOTING GUIDE

While normal care and routine maintenance will extend the life of your rototiller, prolonged or constant use may eventually require that service be performed to allow it to continue operating properly. The troubleshooting guide below lists the most common problems, causes and remedies.

WARNING

PRACTICE SAFETY AT ALL TIMES. ENGINE MUST BE TURNED OFF AND ALLOWED TO COOL, AND SPARK PLUG WIRE MUST BE DISCONNECTED AND SECURED BEFORE ATTEMPTING ANY MAINTENANCE OR REPAIR.

FAILURE TO COMPLY WITH THIS SAFETY REQUIREMENT CAN RESULT IN SERIOUS PERSONAL INJURY TO YOU OR BYSTANDERS.

PROBLEM	REMEDY/ACTION
Engine will not start	<ul style="list-style-type: none"> • Add gas to gas tank. • Connect spark plug wire to spark plug. • Throttle must be positioned at choke for a cold start.
Engine runs rough, floods during operation	<ul style="list-style-type: none"> • Clean or replace air cleaner.
Engine is hard to start	<ul style="list-style-type: none"> • Drain old fuel and replace with fresh. Use gas stabilizer at end of season. • Make sure spark plug wire is securely attached to spark plug. • Drive safety control lever must be released to neutral to start the engine.
Engine misses or lacks power	<ul style="list-style-type: none"> • Raise the tines for shallow tilling by raising the depth regulator lever. • Clean or replace air cleaner. • Improper carburetor adjustment, take to authorized engine service center. • Replace spark plug and adjust gap. • Drain and refill gas tank and carburetor.
Engine will not stop when throttle control is positioned at stop	<ul style="list-style-type: none"> • See engine manual to check and adjust throttle linkage.
Tiller moves forward during starting	<ul style="list-style-type: none"> • Drive safety control lever must be released to neutral to start the engine.
Tiller is difficult to control when tilling (machine jumps or lurches forward)	<ul style="list-style-type: none"> • Lower engine speed in hard ground. • Raise the tines for shallower tilling by lowering the depth regulator lever.
Belts squeal in neutral	<ul style="list-style-type: none"> • Adjust forward belt guide: <ul style="list-style-type: none"> - turn engine off and allow muffler to cool - disconnect spark plug wire and secure from spark plug - pull down on drive safety control lever - manually bend forward belt guide so there is 1/16 inch or less clearance between belt guide and belt - replace spark plug wire
Belts squeal in forward operation	<ul style="list-style-type: none"> • Turn engine off and allow muffler to cool. • Disconnect spark plug wire and secure from spark plug. • Release drive safety control lever to neutral. • Adjust engage cable. • Replace spark plug wire.
Excessive heat build up in transmission/tine area during tilling	<ul style="list-style-type: none"> • Remove vegetation. • Check transmission fluid and fill if needed.

PARTS BREAKDOWN

3365B/3365CE HANDLEBAR PARTS

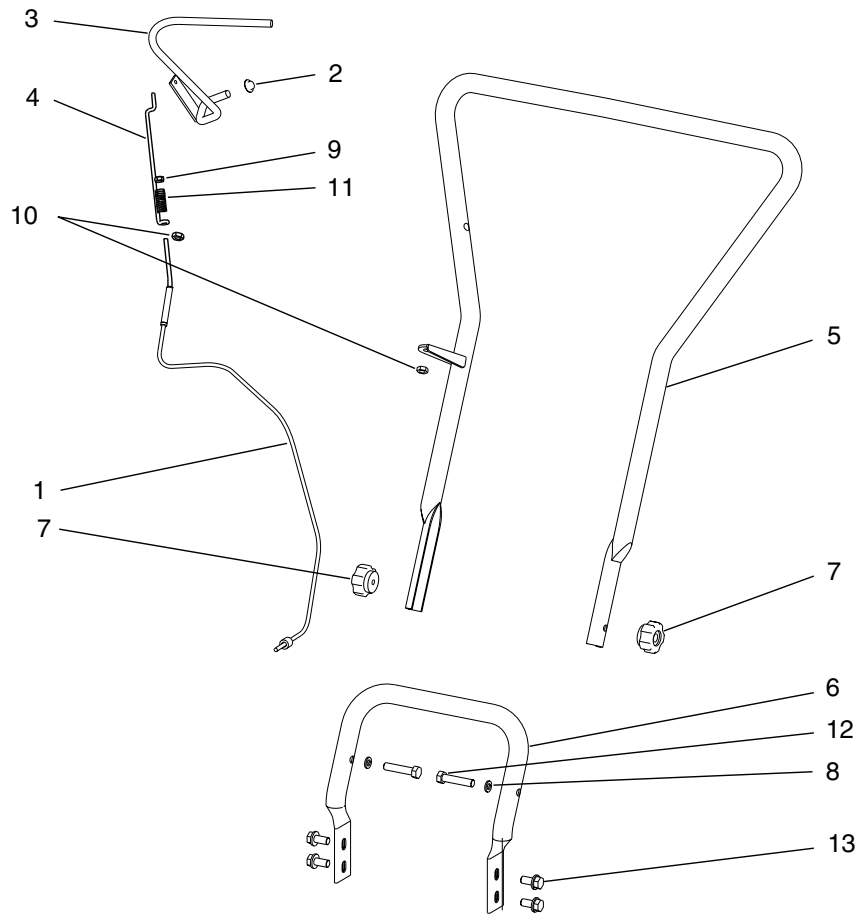

REF. NO.	PART #	DESCRIPTION	QTY.
1	3108A	CABLE ASSEMBLY W/FERREL	1
2	3170	NUT, PUSH 3/8" DIA.	1
3	32621	DRIVE SAFETY CONTROL LEVER (WIDE)	1
4	3268	LINK, 5-3/4" LONG	1
5	3269	HANDLE, TOP	1
6	3335	HANDLE, BOTTOM	1
7	48406	KNOB, FIVE-STAR 5/16-18	2

REF. NO.	PART #	DESCRIPTION	QTY.
8	504	LOCKWASHER, SPRING 5/16"	2
9	53606	NUT, HEX NYLOC 10-24	1
10	53607	NUT, HEX JAM 5/16-24	2
11	53620	SPRING, COMPRESSION	1
12	8655	BOLT, HEX HD 5/16-18 X 1-3/4"	2
13	90141	BOLT, SFHH W/PATCH 3/8-16 X 1" GR5	4

3365PS HANDLEBAR PARTS

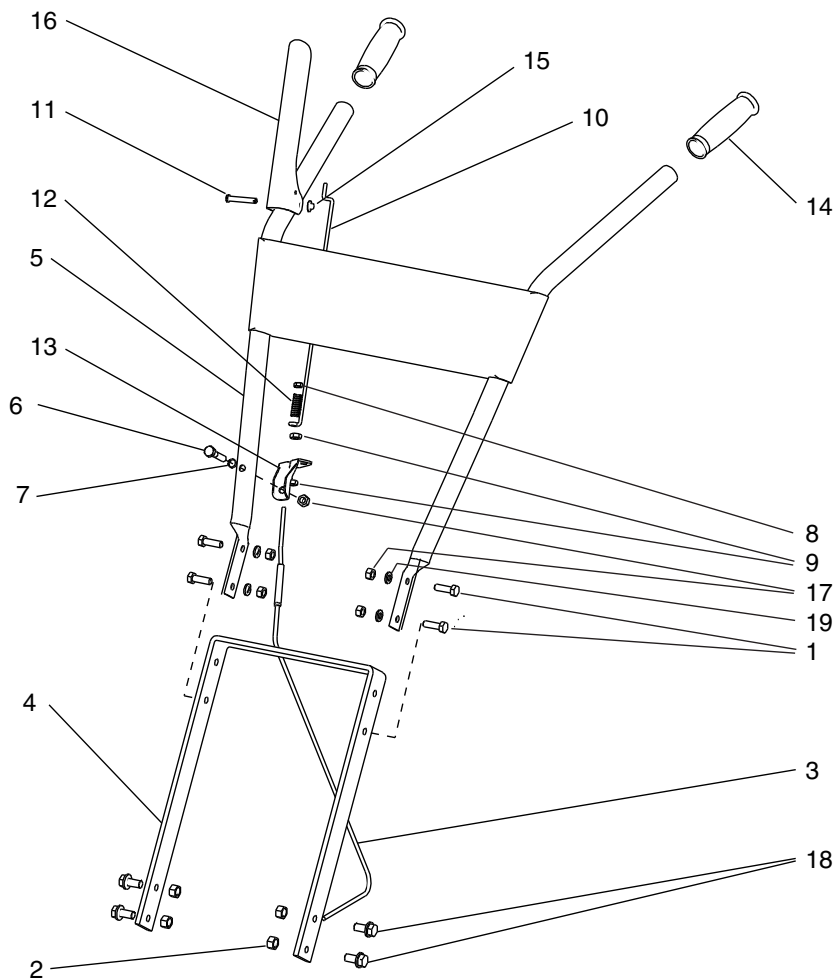

REF. NO.	PART #	DESCRIPTION	QTY.
1	1501	BOLT, SOC FLG HEX HD 5/16-18 X 3/4" GR5	4
2	2104	NUT, BI-WAY HEX LOCK 3/8-16	4
3	3108A	CABLE ASSEMBLY W/FERREL	1
4	3358	MOUNT, HANDLEBAR	1
5	3359	HANDLEBAR WELDMENT	1
6	503	BOLT, HH 5/16-18 X 1-1/2"	1
7	504	LOCKWASHER, SPRING 5/16"	2
8	53606	NUT, HEX NYLOC 10-24	1
9	53607	NUT, HEX JAM 5/16-24	2

REF. NO.	PART #	DESCRIPTION	QTY.
10	53612	LINK 11-5/8" LONG	1
11	53614	PIN, CLEVIS 1/4 X 1-1/2"	1
12	53620	SPRING, COMPRESSION	1
13	53629	BRACKET, CABLE MOUNT	1
14	53631	GRIP, HANDLEBAR 1" ID FLANGELESS	2
15	53632	NUT, PUSH 1/4"	1
16	53650	LEVER, CONTROL	1
17	60G56	NUT, BI-WAY LOCK 5/16-18	5
18	90138	BOLT, SFHH 3/8-16 X 3/4"	4
19	WF516	WASHER, FLAT 5/16"	4

3365PSCE HANDLEBAR PARTS

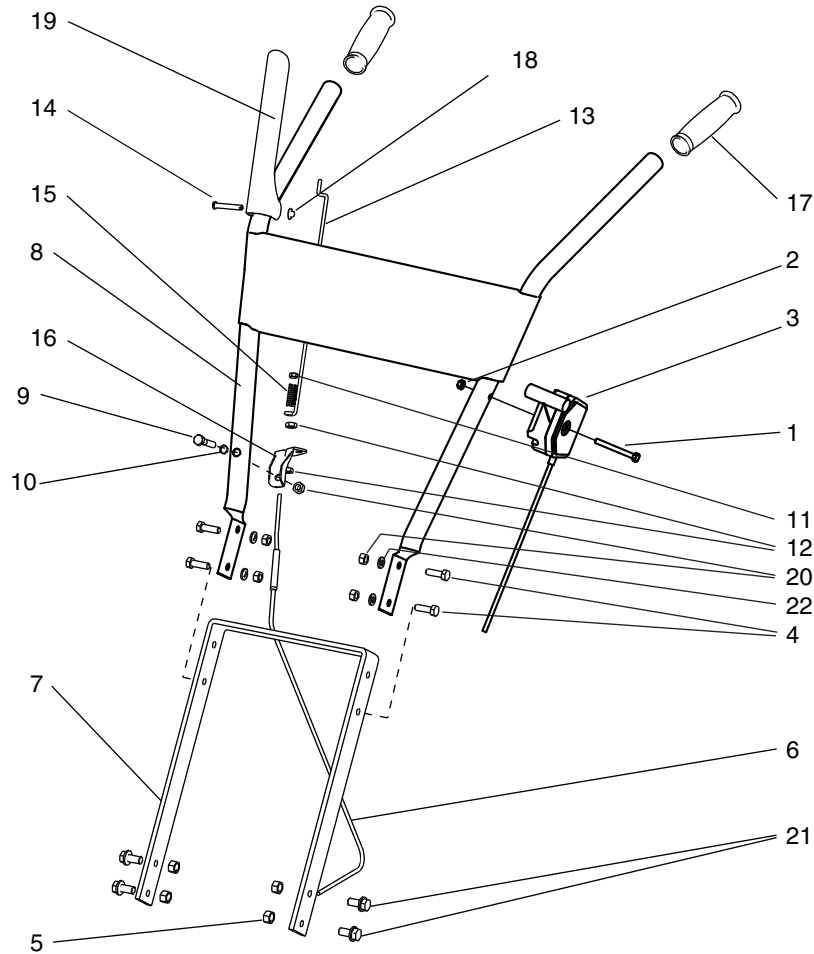

REF. NO.	PART #	DESCRIPTION	QTY.
1	331059	BOLT, HEX	1
2	W1265V0913	NUT, HEX	2
3	3310118	KIT, THROTTLE CONTROL W/HARDWARE	1
4	1501	BOLT, SOC FLG HEX HD 5/16-18 X 3/4" GR5	4
5	2104	NUT, BI-WAY HEX LOCK 3/8-16	4
6	3108A	CABLE ASSEMBLY W/FERREL	1
7	3358	MOUNT, HANDLEBAR	1
8	3359	HANDLEBAR WELDMENT	1
9	503	BOLT, HH 5/16-18 X 1-1/2"	1
10	504	LOCKWASHER, SPRING 5/16"	2
11	53606	NUT, HEX NYLOC 10-24	1

REF. NO.	PART #	DESCRIPTION	QTY.
12	53607	NUT, HEX JAM 5/16-24	2
13	53612	LINK 11-5/8" LONG	1
14	53614	PIN, CLEVIS 1/4 X 1-1/2"	1
15	53620	SPRING, COMPRESSION	1
16	53629	BRACKET, CABLE MOUNT	1
17	53631	GRIP, HANDLEBAR 1" ID FLANGELESS	2
18	53632	NUT, PUSH 1/4"	1
19	53650	LEVER, CONTROL	1
20	60G56	NUT, BI-WAY LOCK 5/16-18	5
21	90138	BOLT, SFHH 3/8-16 X 3/4"	4
22	WF516	WASHER, FLAT 5/16"	4

3365B/3365CE/3365PS/3365PSCE MOTOR MOUNT AND HOOD PARTS

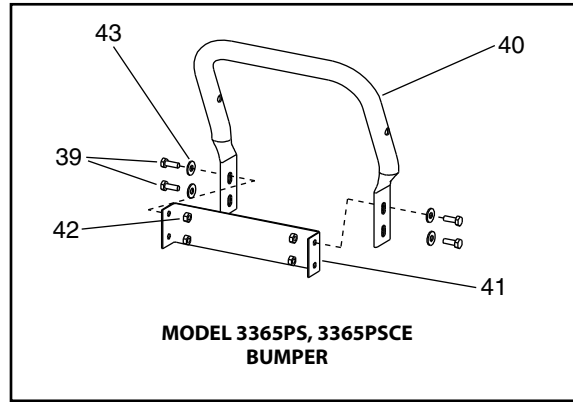
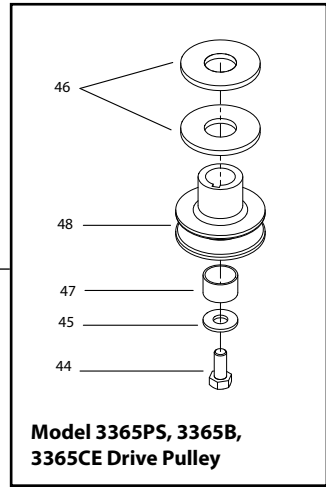
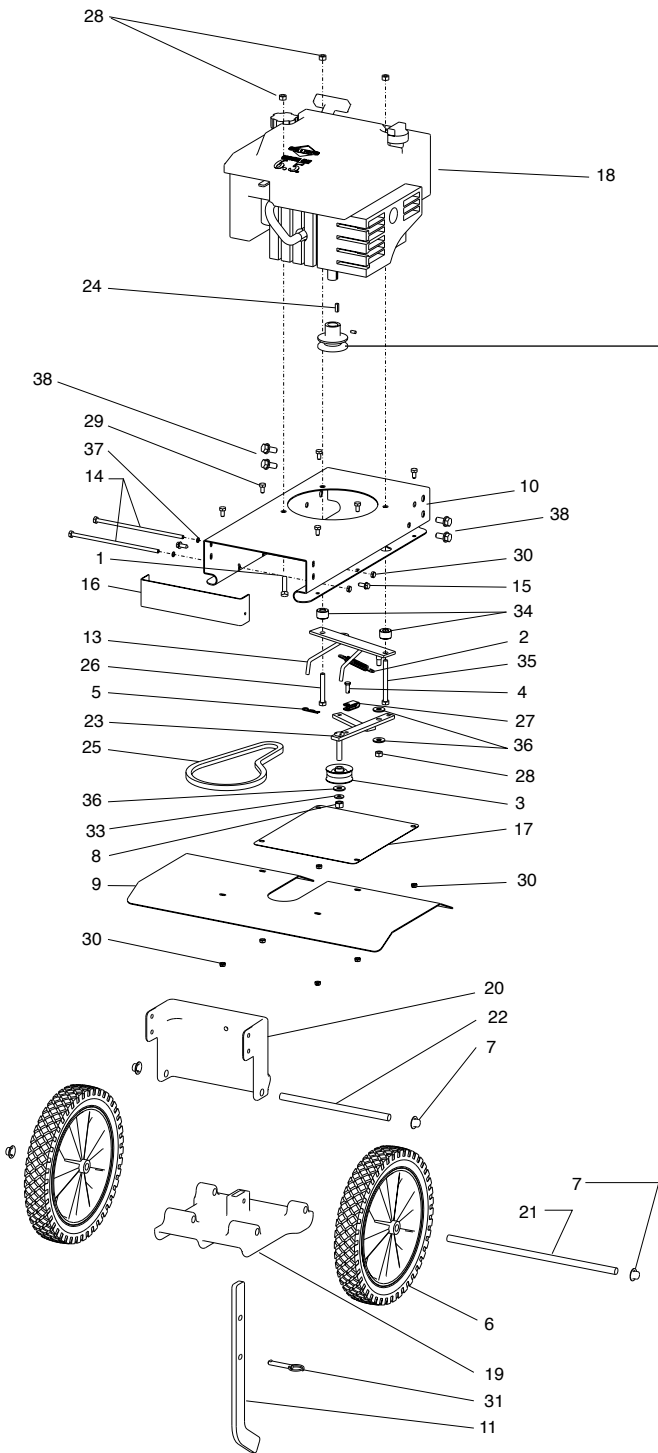

3365B/3365CE/3365PS/3365PSCE MOTOR MOUNT AND HOOD PARTS

REF. NO.	PART #	DESCRIPTION	QTY.	REF. NO.	PART #	DESCRIPTION	QTY.
1	1401	BOLT, HHCS 5/16-18 X 1-1/4" GR5	1	25	3370	BELT, FORWARD	1
2	1407	SPRING, FORWARD ARM	1	26	48300	BOLT, HHCS 5/16-18 X 2-1/4" GR5	1
3	1413	PULLEY, FORWARD IDLER	1	27	53596B	YOKE, CABLE	1
4	1416	PIN, LINK	1	28	60G56	NUT, BI-WAY LOCK 5/16-18	4
5	1418	PIN, COTTER	1	29	63118	BOLT, HHCS 1/4-20 X 1/2"	6
6	1714252	WHEEL & TIRE ASSY 11.0 X 1.75	2	30	67538	NUT, HEX NYLOC 1/4-20	8
7	1960519	PUSH NUT 1/2" DIA.	4	31	69170	PIN, DETENT 5/16" X 2"	1
8	2108	NUT, NON-LOCKING HEX 3/8-16	1	32	--	--	--
9	3128	SHIELD, TINE	1	33	719	WASHER, SPRING LOCK 3/8"	1
10	3130A	FRAME, ENGINE MOUNT	1	34	744	SPACER, BELT GUIDE	2
11	3157	LEVER, DEPTH REGULATOR	1	35	90140	BOLT, HEX HD 5/16-18 X 3-1/4"	1
12	--	--	--	36	WF516	WASHER, FLAT 5/16"	3
13	3182A	BELT GUIDE & MOUNT	1	37	WL14	WASHER, SPRING LOCK 1/4"	2
14	3196	BOLT, HHCS 1/4-20 X 7-1/2" GR5	2	38	90141	BOLT 3/8-16X1 SFHH GR5ZN W PATCH	4
15	3202	SCREW, SHEET METAL 1/4 X 3/4" (3365, 3365B,3365CE)	2	MODEL 3365PS/3365PSCE BUMPER GUARD PARTS			
16	3237	COVER, FRONT BELT (3365, 3365B,3365CE)	1	39	1516	BOLT, SOC FLANGE HEX HD, 1/4-20 X 3/4"	4
17	3275	SHIELD, DIRT	1	40	3335	ARM LOWER HANDLEBAR	1
18	3305	ENGINE, 6.75 T.R. BRIGGS (3305, 3365PS, 3365B, 3365CE)	1	41	3371	COVER, FRONT 4-HOLE (replaces 3237)	1
18	3305CE	ENGINE, 5.50 T.R. BRIGGS (3306, 3365)	1	42	67538	NUT, HEX NYLOC 1/4-20	4
18	3306	ENGINE, 6.75 T.R. BRIGGS (3365B, 3365PS)	1	43	WF14	WASHER, FLAT 1/4"	4
18	3307CE	ENGINE, 8.5 T.R. BRIGGS (3365PSCE)	1	MODEL 3365PS, 3365PSCE DRIVE PULLEY PARTS			
19	3330	TAIL MOUNT, LOWER	1	44	807	BOLT 5/16-24X3/4 W/PATCH BHSCS	1
20	3329	TAIL MOUNT, UPPER	1	45	809	WASHER FLAT 1" OD X .047 SPACER	1
21	3331	SHAFT, WHEEL 1/2"	1	46	3207	SPACER .055 THICK X .755 ID X 1.244 OD	2
22	3332	SHAFT, TAIL MOUNT HINGE 1/2"	1	47	741	SPACER DRIVE PULLEY .900"	1
23	3360	IDLER ARM, FORWARD	1	48	3178	PULLEY SINGLE GROOVE ENGINE	1
24	3364	KEY, SQUARE 3/16" X 5/8"	1				

TINES & TRANSMISSION PARTS

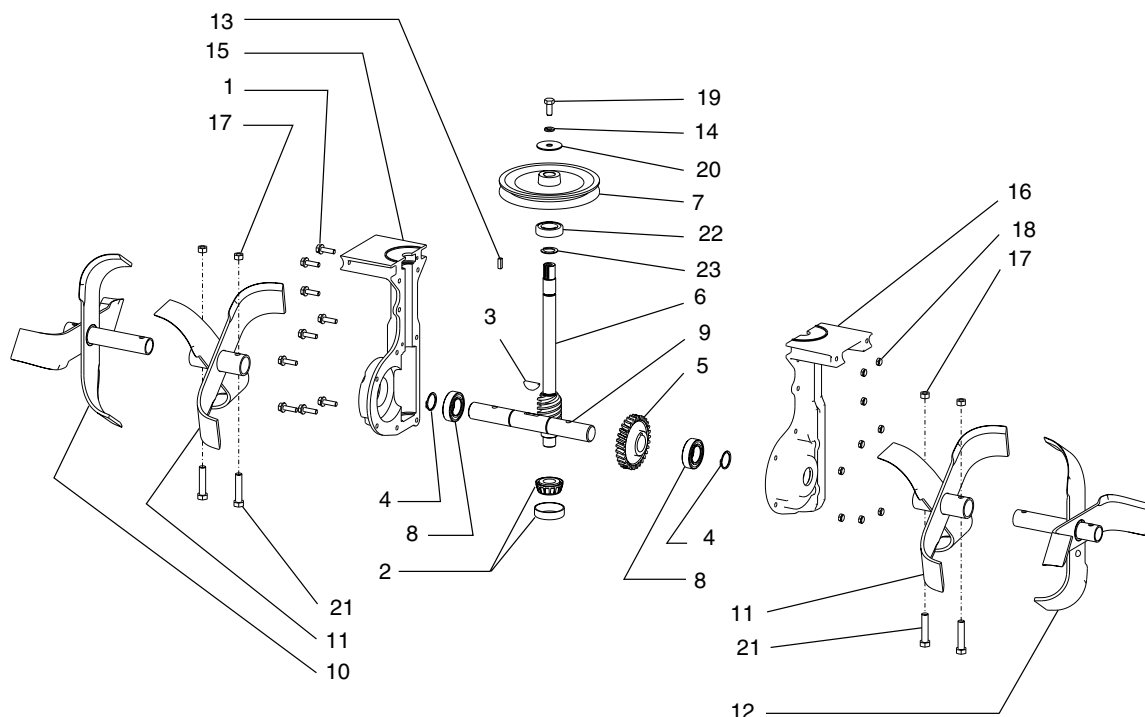

REF. NO.	PART #	DESCRIPTION	QTY.
1	1511	BOLT, SFHH 1/4-20 X 7/8"	9
2	1601	BEARING, TAPERED (includes cone & race)	1
3	1701	KEY, HALF MOON 1/4 X 1"	1
4	1810	SNAP RING, EXTERNAL	2
5	3116	GEAR, BRASS 1" ID	1
6	3122	SHAFT, DRIVE	1
7	3179	PULLEY, SINGLE GROOVE	1
8	3205W	BEARING, SEALED 1" ID (replaces 3205 bearing & 747 spacer)	2
9	3322	SHAFT, TINE 1"	1
10	3323	TINE SET, OUTSIDE RIGHT	1
11	3324	TINE SET, INSIDE	2
12	3326	TINE SET, OUTSIDE LEFT	1

REF. NO.	PART #	DESCRIPTION	QTY.
13	3364	KEY 3/16 X 1/2"	1
14	504	LOCKWASHER, SPRING 5/16"	1
15	56100B	CASTING, RIGHT SIDE	1
16	56101B	CASTING, LEFT SIDE	1
17	60G56	NUT, BI-WAY LOCK 5/16-18	4
18	67538	NUT, NYLOC 1/4"	9
19	802	SCREW, HEX HD 5/16-24 X 3/4"	1
20	803	WASHER 5/16" ID X 1-5/8" OD	1
21	8655	BOLT, HEX HD 5/16-18 X 1-3/4"	4
22	8922	BEARING, BALL R12	1
23	8924	SNAP RING, EXTERNAL 3/4"	1
24	3310TRAN	TRANSMISSION, COMPLETE	1
25	3334	KIT, TINES W/ DRAG STAKE (not shown)	1



FRONT TINE ROTOTILLERS

1-YEAR LIMITED WARRANTY

Terms and Conditions

Ardisam, Inc., a manufacturing company, warrants this **EARTHQUAKE® FRONT TINE ROTOTILLER** to be free from defects in the material or workmanship for a period of one year from the date of purchase. During the one-year warranty of this product, Ardisam will, at their discretion, furnish parts and labor to correct any defect caused by faulty material or workmanship. Items subject to normal wear and tear, such as belts, batteries, tines, shear bolts and tires, due to the nature of their function are not covered under this warranty. Any unit used in a commercial application is covered for a period of 90 days after purchase. The engine is covered under a separate warranty issued by the engine manufacturer as stated in the engine manual.

If warranty work needs to be done, contact your place of purchase or Ardisam, Inc., for an authorized service center in your area. Ardisam will make the necessary repairs if a service center is not available. **To obtain warranty service and/or replacement instructions, you must have prior approval from Ardisam before shipping your package to us by calling our customer service department at 800-345-6007 Monday through Friday from 8 a.m. to 5 p.m., for a return material authorization number (RMA#).** All items must be shipped prepaid. Ardisam, Inc. will at no charge, repair or replace, at their discretion, any defective part which falls under the conditions stated above.

Ardisam retains the right to change models, specifications and price without notice. This product if used as intended, will give you years of trouble free service. We hope you will enjoy the quality of our products for years to come.

For replacement parts, phone 800-345-6007 or go online to www.GetEarthquake.com.

This warranty applies to the original owner with a proof of purchase and is not transferable. It supersedes all other warranties either expressed or implied and all other obligations to liabilities on our part. Ardisam, Inc. does not assume, and does not authorize any other person to assume for us, any liability in connection with the sale of our products.

The warranty applies only to products which have not been subjected to negligent use, misuse, alteration, accident or repairs made by anyone not certified by Ardisam, Inc. This guarantee is void unless the warranty card is properly filled out and received by Ardisam, Inc., within 30 days of purchase or go to www.GetEarthquake.com for online registration.

EARTHQUAKE
A Division of Ardisam, Inc.
1160 Eighth Avenue; P.O. Box 666
Cumberland, Wisconsin 54829
800-345-6007 · Fax (715) 822-4180
E-mail: info@ardisam.com

IMPORTERS/ REPAIR CENTERS (FOR U.K. CUSTOMERS)

**ROCHFORD GARDEN MACHINERY LTD.
WINCANTON BUSINESS PARK , WINCANTON
SOMERSET, ENGLAND, BA9, 9RS**



Earthquake®, Division of Ardisam, Inc.
1160 8th Avenue, PO Box 666
Cumberland, WI 54829
800-345-6007 | Fax 715-822-2223
Email: info@ardisam.com

Free Manuals Download Website

<http://myh66.com>

<http://usermanuals.us>

<http://www.somanuals.com>

<http://www.4manuals.cc>

<http://www.manual-lib.com>

<http://www.404manual.com>

<http://www.luxmanual.com>

<http://aubethermostatmanual.com>

Golf course search by state

<http://golfingnear.com>

Email search by domain

<http://emailbydomain.com>

Auto manuals search

<http://auto.somanuals.com>

TV manuals search

<http://tv.somanuals.com>