

Item #1000 603 404
Model #TA-2530B



USE AND CARE GUIDE

8 GALLON PORTABLE AIR COMPRESSOR

Questions, problems, missing parts?
Before returning to the store, call
Husky Customer Service
8 a.m. - 6 p.m., EST, Monday-Friday

1-888-43-HUSKY

HUSKYTOOLS.COM

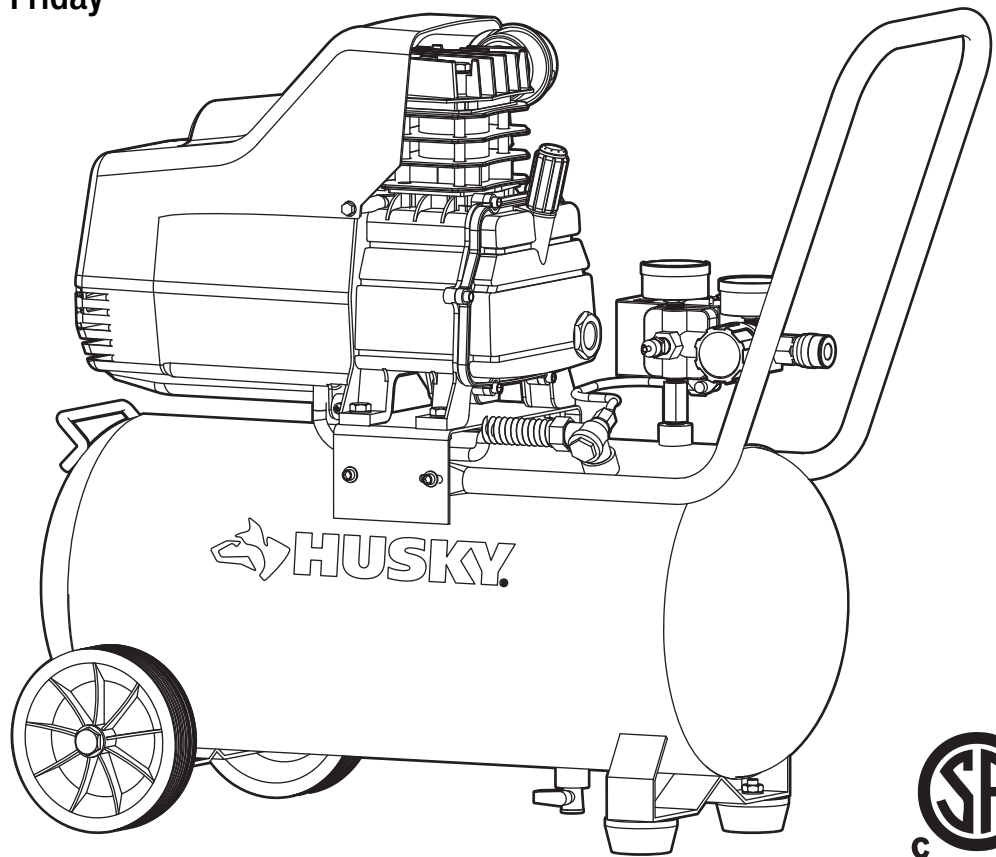

THANK YOU

We appreciate the trust and confidence you have placed in Husky through the purchase of this air compressor. We strive to continually create quality products designed to enhance your home. Visit us online to see our full line of products available for your home improvement needs. Thank you for choosing Husky!

Table of Contents

Table of Contents.....	2	Tools Required	6
Safety Information.....	2	Hardware Included.....	6
Work area safety.....	2	Package Contents	7
Personal Safety	2	Assembly	8
Air Compressor and Pneumatic Tool Safety.....	3	Compressor Operation.....	10
Electrical Safety (Extension Cords)	3	Maintenance	11
Electrical Safety (Electrical Connection)	4	General Maintenance	11
Electrical Safety (Speed And Wiring)	4	Recommended Oil.....	11
Electrical Safety (Grounding Instructions).....	4	Checking The Pump Oil.....	11
Warranty	5	Adding Pump Oil	11
Husky Air Compressor Limited Two-Year Warranty.....	5	Changing Pump Oil.....	12
Additional Limitations	5	Troubleshooting.....	13
Specifications	5	Service Parts	14
Air Compressor	5	Exploded View.....	14
Pre-Assembly	6	Parts table.....	15
Packing List	6		

Safety Information

WORK AREA SAFETY

1. Keep your work area clean and well lit. Ensure floors are not slippery from wax or dust.
2. Do not operate power tools in explosive atmospheres, such as in the presence of flammable liquids, gases, or dust. Power tools create sparks which may ignite the dust or fumes. Keep bystanders, children, and visitors away while operating tools. Distractions can cause you to lose control.
3. Operate the air compressor in an open area at least 18 in. away from any wall or object that could restrict the flow of fresh air to the ventilation openings.
4. Always disconnect the air supply and power supply before making adjustments, servicing a tool, or when a tool is not in use.
5. This compressor/pump is not equipped and should not be used to supply breathing quality air. Additional equipment is necessary to properly filter and purify the air to meet minimal specifications for Grade D breathing as described in Compressed Gas Association Commodity Specification G 7.1 - 1966, OSHA 29 CF9 1910.134. Compressed Gas Association, 4221 Walney Road, Fifth Floor, Chantilly, VA 20151-2923
(703) 788 2700, www.cganet.com.
Any such additional equipment has not been examined and no implication of proper use for breathing air is intended or implied.

PERSONAL SAFETY



WARNING: Operating any power tool can result in foreign objects being thrown into your eyes, which can result in severe eye damage. Before beginning operation, always wear safety goggles, safety glasses with side shields, or a full face shield when needed. Always use eye protection marked to comply with ANSI Z87. 1.



WARNING: This product contains chemicals known to the State of California to cause cancer and birth defects or other reproductive harm. Wash hands after handling.

1. Use safety equipment. Always wear eye protection with side shields when operating power tools. A dust mask, nonskid safety shoes, a hard hat, or hearing protection must be used for appropriate conditions.
2. Stay alert when operating a power tool. Do not use the tool while tired or under the influence of drugs, alcohol, or medication.
3. Do not wear loose clothing or jewelry. Contain long hair. Keep your hair, clothing, and gloves away from moving parts. Loose clothes, jewelry, or long hair can be caught in moving parts.
4. Keep proper footing and balance at all times. Proper footing and balance enables better control of the tool in unexpected situations.
5. Do not use on a ladder or unstable support.

Safety Information (continued)

AIR COMPRESSOR AND PNEUMATIC TOOL SAFETY



WARNING: Do not attempt to modify this tool or create accessories not recommended for use with this tool. Any such alteration or modification is misuse and could result in a hazardous condition leading to possible serious personal injury.



CAUTION: Do not use in an environment that is dusty or otherwise contaminated. Using the air compressor in this type of environment may cause damage to the unit.

1. Keep compressors as far from the spraying area as possible, at least 15 ft. from the spraying area and all explosive vapors.
2. Risk of bursting. Do not adjust the regulator to result in output pressure greater than the marked maximum pressure of the attachment. Do not use at pressure greater than the rated maximum pressure of this compressor.
3. If connected to a circuit protected by fuses, use time-delay fuses with this product.
4. To reduce the risk of electric shock, do not expose to rain. Store indoors.
5. Ensure the hose is free of obstructions or snags. Entangled or snarled hoses can cause loss of balance or footing and may become damaged.
6. Use the air compressor only for its intended use. Do not alter or modify the unit from the original design or function. Never weld or drill holes in the air tank.
7. Never leave a tool unattended with the air hose attached.
8. Do not operate this tool if it does not contain a legible warning label.
9. Do not continue to use a tool or hose that leaks air or does not function properly.
10. Do not attempt to pull or carry the air compressor by the hose.
11. Your tool may require more air consumption than this air compressor is capable of providing.
12. Never direct a jet of compressed air toward people or animals.
13. Protect your lungs. Wear a face or dust mask if the operation is dusty.
14. Do not use this air compressor to spray chemicals. Your lungs can be damaged by inhaling toxic fumes. A respirator may be necessary in dusty environments or when spraying paint.
15. Do not use this compressor if any parts have been exposed to water.

ELECTRICAL SAFETY

1. Avoid body contact with grounded surfaces such as pipes, radiators, ranges, and refrigerators. There is an increased risk of electric shock if your body is grounded.
2. Do not expose power tools to rain or wet conditions. Water entering a power tool will increase the risk of electric shock.
3. Do not abuse the cord. Never use the cord to carry the tool or pull the plug from an outlet. Keep the cord away from heat, oil, sharp edges, and moving parts.
4. Replace damaged cords immediately. Damaged cords increase the risk of electric shock.

ELECTRICAL SAFETY (EXTENSION CORDS)



WARNING: Keep the extension cord clear of the working area. Position the cord so that it will not get caught on lumber, tools, or other obstructions while you are working with a power tool. Failure to do so can result in serious personal injury.



WARNING: Check extension cords before each use. If damaged, replace immediately. Never use the air compressor with a damaged cord since touching the damaged area could cause electrical shock resulting in serious personal injury.



WARNING: Improperly connecting the equipment-grounding conductor can result in a risk of electrical shock.

1. Use only 3-wire extension cords that have 3-prong grounding plugs and 3-pole receptacles that accept the air compressor's plug.
2. When using the air compressor at a considerable distance from the power source, use an extension cord heavy enough to carry the current that the compressor will draw. An undersized extension cord will cause a drop in line voltage, resulting in a loss of power and causing the motor to overheat. Use the following chart to determine the minimum wire size required in an extension cord.
3. Only use 50 ft. or less round jacketed cords listed by Underwriter's Laboratories (UL).
4. When operating a power tool outside, use an outdoor extension cord marked "w-A" or "w". These cords are rated for outdoor use and reduce the risk of electric shock.

Safety Information (continued)

ELECTRICAL SAFETY (EXTENSION CORDS) (CONTINUED)

Ampere rating (on air compressor data plate)						
	0– 2.0	2.1– 3.4	3.5– 5.0	5.1– 7.0	7.1– 12.0	12.1– 16.0
Cord Length	Wire Size (A.W.G)					
25 ft.	16	16	16	16	14	14
50 ft.	16	16	16	14	14	12
100 ft.	16	16	14	12	10	–

Used in 12 gauge – 20 amp circuit.



NOTE: Use longer air hoses instead of long extension cords. Your air compressor will run better and last longer.

ELECTRICAL SAFETY (ELECTRICAL CONNECTION)

1. This air compressor is powered by a precision built electric motor. It should be connected to a power supply that is 120 volts, 60 Hz, AC only (normal household current).
2. Do not operate this tool on direct current (DC). A substantial voltage drop will cause a loss of power and the motor will overheat. If the air compressor does not operate when plugged into an outlet, double check the power supply.

ELECTRICAL SAFETY (SPEED AND WIRING)

1. The no-load speed of the electric motor varies by model and specification. The motor speed is not constant and decreases under a load or with lower voltage. For voltage, the wiring in a shop is as important as the motor's horsepower rating.
2. A line intended only for lights cannot properly carry a power tool motor. Wire that is heavy enough for a short distance will be too light for a greater distance. A line that can

support one power tool may not be able to support two or three tools.

ELECTRICAL SAFETY (GROUNDING INSTRUCTIONS)

1. This product must be grounded. In the event of an electrical short circuit, grounding reduces the risk of electric shock by providing an escape wire for the electric current. This air compressor is equipped with an electric cord having an equipment-grounding conductor and a grounding plug. The plug must be plugged into a matching outlet that is properly installed and grounded in accordance with all local codes and ordinances
2. Do not modify the plug provided. If it will not fit the outlet, have the proper outlet installed by a qualified electrician.
3. The conductor with insulation having an outer surface that is green with or without yellow stripes is the equipment grounding conductor. If repair or replacement of the electric cord or plug is necessary, do not connect the equipment grounding conductor to a live terminal.
4. Check with a qualified electrician or service personnel if you do not completely understand the grounding instructions, or if you are in doubt as to whether the tool is properly grounded. This product is for use on a nominal 120-V. Do not use an adapter with this product.

Warranty

HUSKY AIR COMPRESSOR LIMITED TWO-YEAR WARRANTY

This warranty covers defects in workmanship or materials in this Husky air compressor for the two-year period from the date of purchase. This warranty is specific to this air compressor model. Warranties for other Husky products may vary. This warranty applies only to the original retail purchaser and may not be transferred. This warranty does not cover normal wear and tear or any malfunction, failure or defect resulting from misuse, abuse, neglect, alteration, modifications or repair by other than a service center authorized to repair Husky branded air compressors. Expendable materials, such as motor brushes, seals, etc. are not covered by this warranty. This warranty does not apply to this compressor used in industrial applications or for rental purposes. Husky makes no warranties, representations, or promises as to the quality or performance of its air compressors other than those specifically stated in this warranty.

ADDITIONAL LIMITATIONS

To the extent permitted by applicable law, all implied warranties, including warranties of merchantability or fitness for a particular purpose, are disclaimed. Any implied warranties, including warranties of merchantability or fitness for a particular purpose, that cannot be disclaimed under state law are limited to two years from the date of purchase. Husky is not responsible for direct, indirect, incidental, special or consequential damages. If this air compressor is used for commercial purposes, the warranty will apply for ninety (90) days from the date of purchase. Some states do not allow limitations on how long an implied warranty lasts and/or do not allow the exclusion or limitation of incidental or consequential damages, so the above limitations may not apply to you. This warranty gives you specific legal rights, and you may also have other rights, which vary from state to state.

Contact the Customer Service Team at 1-888-43-HUSKY or visit www.HomeDepot.com.

Specifications

AIR COMPRESSOR

Running horsepower	1.5 HP
Air tank capacity	8 gal.
Air pressure	125 PSI max.
Air delivery	5.0 SCFM at 40 PSI 4.0 SCFM at 90PSI
Lubrication	Oil lubricated
Gauges	(2) gauge 2 in. diameter
Input	120 V. 60 Hz. AC only. 12.5 Amps.
Net weight	61.7 lbs.
Fill time	(0 PSI – 125 PSI): approximately 2 minutes 15 seconds (135 seconds)

Pre-Assembly

PACKING LIST

Before assembling and operating this air compressor, ensure the following items are identified in the packaging:

- Air compressor
- Air filter (L)
- Wheel assembly package (includes 2 wheels (D), 2 shoulder bolts (AA), 2 nuts (BB), and 2 lock washers (CC))
- Handle assembly package (includes 1 Handle (A), 4 screws (DD), 4 flat washers (EE))
- Oil bottle (M)

TOOLS REQUIRED

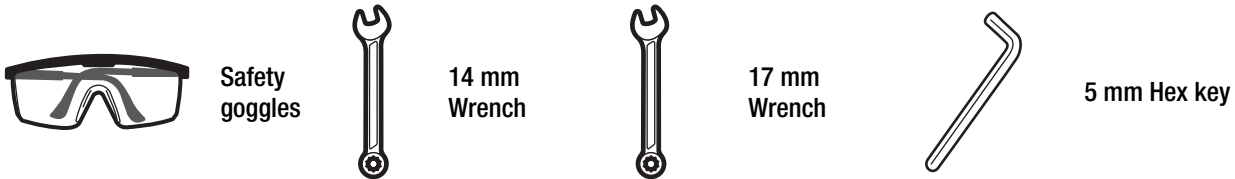

HARDWARE INCLUDED



NOTE: Hardware not shown to actual size.



Part	Description	Quantity
AA	10 mm shoulder bolt	2
BB	10 mm nut	2
CC	Lock washer	2
DD	6 mm screw	4
EE	6 mm flat washer	4

Pre-Assembly (continued)

PACKAGE CONTENTS

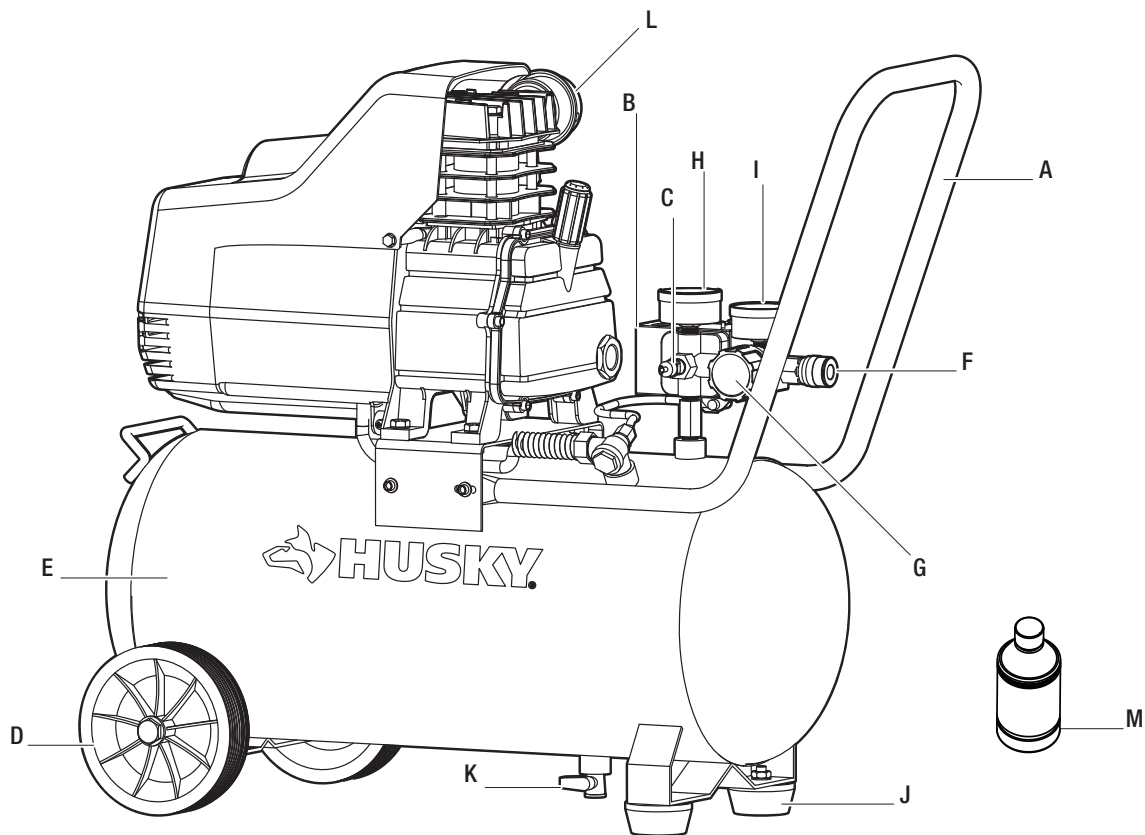

Part	Description	Quantity
A	Handle	1
B	Manual AUTO/OFF switch	1
C	Safety valve	1
D	Wheel	2
E	Tank	1
F	Quick coupler	1
G	Pressure regulator knob	1
H	Tank pressure gauge	1
I	Regulator pressure gauge	1
J	Rubber foot	2
K	Drain valve	1
L	Air filter	1
M	Oil bottle	1

Assembly

1 Assembling the wheels

- With the offset hub of a wheel (D) facing the tank's wheel bracket, assemble a 10 mm shoulder bolt (AA) through the holes in the wheel and tank wheel bracket.
- Place a lock washer (CC) onto the threaded end of the shoulder bolt (AA). Then, place a 10 mm nut (BB) on the threaded end of the bolt (AA) and tighten securely.
- Repeat for the other wheel (D).

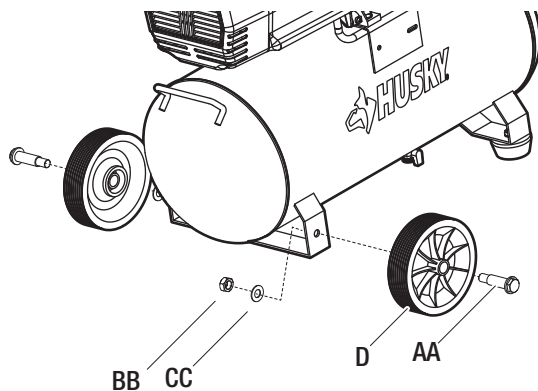

2 Assembling the handle

- Insert the two open ends of the handle (A) into the handle brackets on the air compressor tank.
- Align the holes in the handle bracket with the threaded holes in the handle (A).
- Attach the handle (A) to both sides of the air compressor using 6 mm flat washers (EE) and 6 mm screws (DD). Tighten securely.

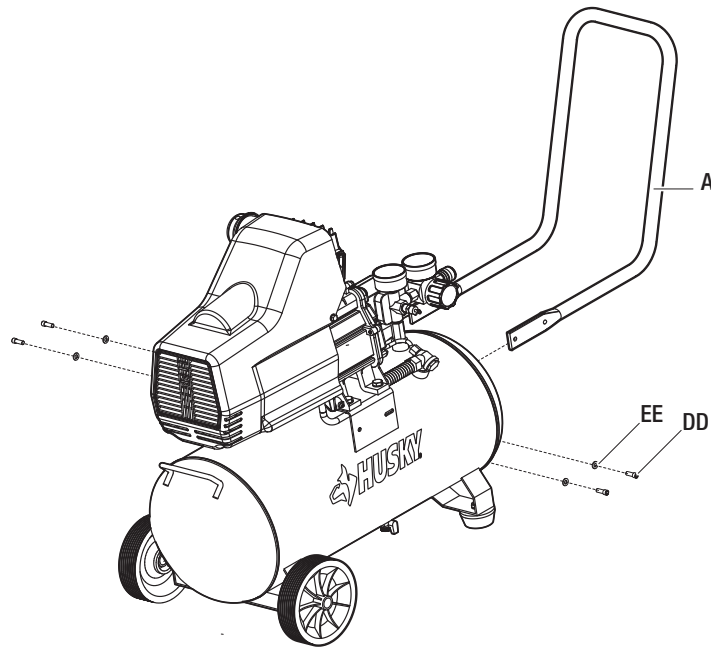

3 Attaching the air filter

- Insert the threaded end of the air filter (L) into the threaded port of the pump head. Do not apply thread tape to the air filter assembly's threads.
- Rotate clockwise to tighten. Hand tighten only.

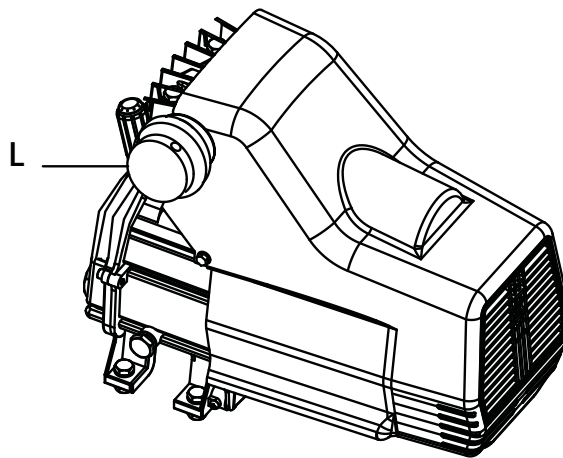

Assembly

4 Air compressor lubrication



CAUTION: This unit is shipped without oil in the pump! Follow these lubrication instructions before operating the compressor.

- Add oil to the pump using the oil bottle (M). The compressor pump holds approximately 380 ml (13 oz.) of oil. The sight glass, located on the crankcase portion of the pump, is used to maintain proper oil level. The “Max” oil level is when the oil is in the center of the dot in the middle of the sight glass. “Min” oil level is at the bottom of the dot in the center of the sight glass. Avoid overfilling by adding oil gradually and checking the oil level with the sight glass several times. Add enough oil to reach the “Max” level on the sight glass. Proper oil level is illustrated here:

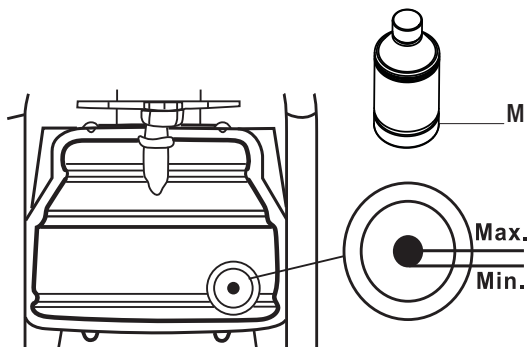

5 Breaking in the pump

- Check and tighten all bolts and fittings.
- Open the air flow by turning the pressure regulator knob (G) fully clockwise.
- Place the AUTO/OFF switch (B) in the OFF position and plug in the power cord.
- Open the drain valve (K).
- Place the AUTO/OFF switch (B) in the ON position and run the air compressor for 10 minutes.
- Place the AUTO/OFF switch (B) in the OFF position.
- Close the drain valve (K).

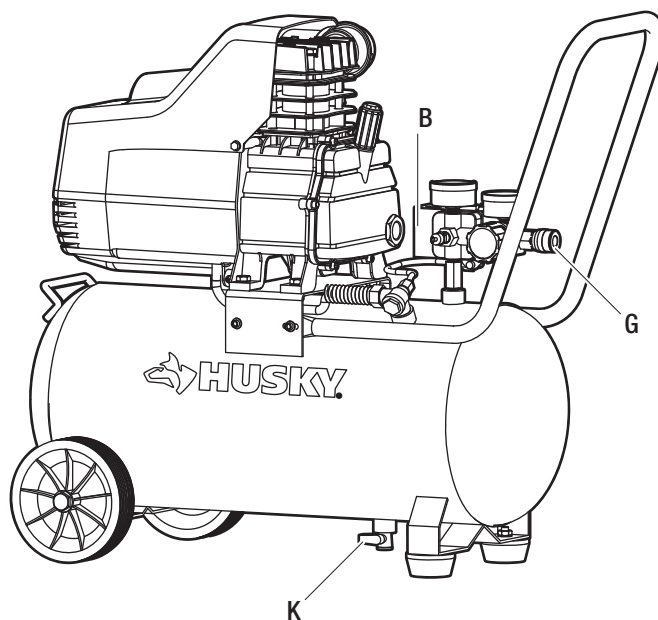

Compressor Operation

1 Draining the tank

- Turn off the compressor.
- Pull the safety valve pull ring (C) to remove all air pressure from the tank. Continue to hold the safety valve open until both pressure gauges show 0 PSI. Next, unplug the air compressor from the power source.
- Position a suitable container below the drain valve. Fully open the drain valve (K).
- Keep the compressor tilted until all moisture has been removed.
- If the drain valve (K) is clogged, unplug the compressor and pull the drain valve (K) to remove all air pressure. Remove and clean the drain valve (K) and then reinstall it. Apply sealant tape (not included) to the threads of the drain valve (K) to reduce the likelihood of air leaks.
- Completely close the drain valve (K).



WARNING: Failure to unplug the air compressor and depressurize the tank before removing the valve may cause serious personal injury.



NOTE: Because condensate is a pollutant, dispose of it in compliance with local regulations.

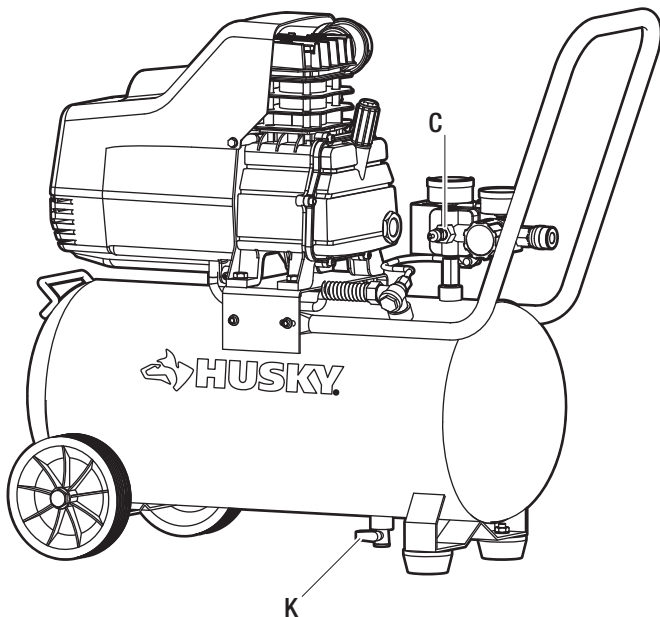

2 Checking the safety valve

- Turn on the air compressor and wait for the tank to fill. The compressor automatically shuts off when the pressure reaches the preset maximum.
- Turn off the air compressor.
- Pull the ring on the safety valve (C) for 20 seconds to release the air.
- Release the ring. Air stops escaping at approximately 40-100 PSI. If the safety valve does not reset stop dispelling air between 40-100 PSI. Discontinue use and seek service before using the air compressor again.



DANGER: Do not tamper with the safety valve. Items loosened from this device could fly up and hit you. Failure to heed this warning could result in death or serious personal injury. The safety valve automatically releases air when the receiver pressure exceeds the preset maximum. Check the valve.



WARNING: Air leaks after releasing the safety valve ring or if the valve is stuck. Do not use the air compressor until the safety valve has been replaced. Using the air compressor in this condition could result in serious personal injury.

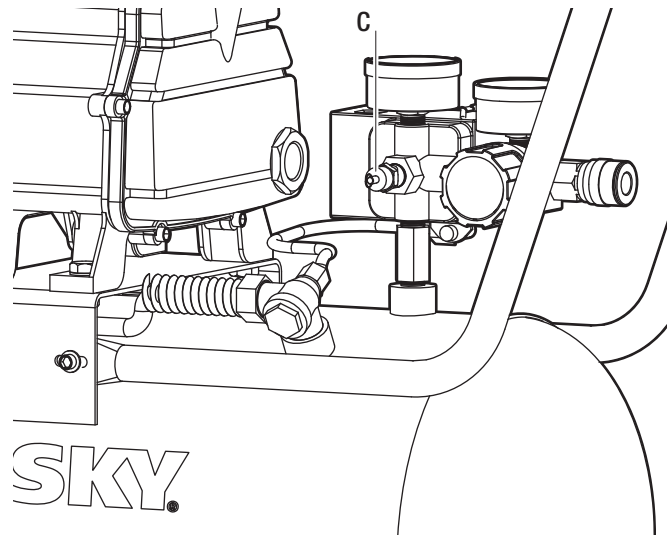

Maintenance

GENERAL MAINTENANCE

Condensate forms in the tank when there is humidity in the air. Depending on the environmental conditions, drain the condensate daily and/or every hour. For instructions, see *Draining the tank* on page 9. The safety valve automatically releases air when the receiver pressure exceeds the preset maximum. Inspect the tank annually for rust, pin holes, or other imperfections that could cause it to become unsafe. Avoid using solvents when cleaning plastic parts. Most plastics are susceptible to damage from various types of commercial solvents and may be damaged by their use. Use a clean cloth to remove dirt, dust, oil, grease, etc.

RECOMMENDED OIL

Use only synthetic and conventional oils specifically designed for air compressor use. These oils can be purchased at The Home Depot and other places oil lubricated air compressors are sold.

CHECKING THE PUMP OIL

1. Unplug the compressor, and allow the oil to settle into the crankcase for at least 2 minutes.
2. Verify the oil level using the red dot in the sight glass on the front of the pump crankcase. (MAX oil level is when the oil level is in the center of the red dot, and MIN oil level is when the oil is at the bottom of the red dot. See the illustration below.)
3. If the oil level is in the center of the red dot, no oil needs to be added. If the oil level is at or near the bottom of the red dot, oil should be added.

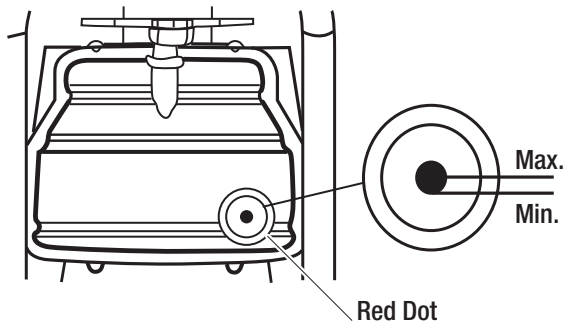

ADDING PUMP OIL

1. (This step is only required if the steps above in *CHECKING PUMP OIL* were followed and oil needs to be added.)
2. Remove the oil vent cap. The vent cap is threaded, so remove it by turning it counterclockwise.
3. Add air compressor oil slowly to avoid overfilling the crankcase. Pour very small amounts, approximately 1 oz., and allow 10–15 seconds for the oil to settle into the crankcase. When the oil level reaches the center of the red dot in the oil sight glass, you have added sufficient oil.



WARNING: Do not allow brake fluids, gasoline, petroleum based products, etc., to come in contact with plastic parts. Chemicals can weaken or destroy plastic which may result in serious personal injury.



WARNING: When servicing, use only identical Husky replacement parts. Use of any other parts may create a hazard or cause product damage.



WARNING: Always disconnect the air compressor from the power supply. Release all pressure, and allow to cool before cleaning or making repairs to the air compressor.

4. Replace the oil vent cap by threading it clockwise into the crankcase opening. Do not over-tighten the oil vent cap, as this can cause damage to the oil vent cap.

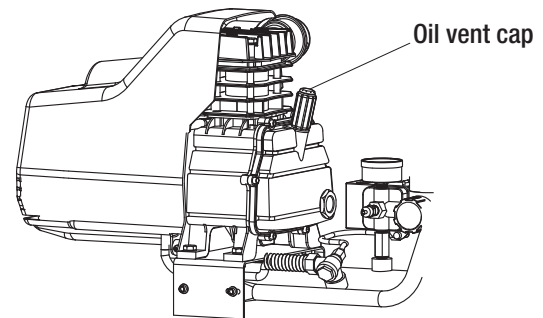

Maintenance (continued)

CHANGING PUMP OIL

The pump's oil should be changed every 100 hours of use. Use only approved air compressor oil when changing this pump's oil or the pump may be damaged.

1. Plug in the compressor and allow it to run for 5 minutes to warm up the oil.
2. Unplug the compressor.
3. Place a suitable oil drain container under the oil drain plug located on the side of the crankcase. Secure the oil drain container.
4. Remove the oil drain plug using a wrench by turning it counter-clockwise.
5. Allow the oil to drain from the pump for several minutes.
6. Replace the oil drain plug by threading it clockwise. Do not over tighten the drain plug, as this can damage the air compressor.
7. Remove the oil vent cap by threading it counterclockwise.
8. Pour approved air compressor oil into the crankcase following the CHECKING THE PUMP OIL section above to assure the crankcase is properly filled. (The crankcase will hold approximately 13 oz. of oil.)

9. Replace the oil vent cap by threading it clockwise into the crankcase opening. Do not over-tighten the oil vent cap, as this can cause damage to the oil vent cap.
10. Remove the waste oil container and properly dispose of the oil.

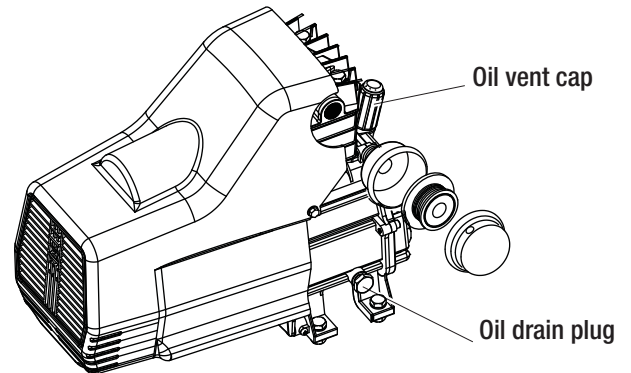

Troubleshooting

Problem	Possible Cause	Solution
The compressor will not run.	<ul style="list-style-type: none"> <input type="checkbox"/> There is loss of power or overheating. <input type="checkbox"/> There is no electrical power. <input type="checkbox"/> There is a blown shop/house fuse. <input type="checkbox"/> The shop/house breaker tripped or the pressure switch is bad. <input type="checkbox"/> The tank is full of air. <input type="checkbox"/> The overload protector tripped. 	<ul style="list-style-type: none"> <input type="checkbox"/> Check the proper use of the extension cord. <input type="checkbox"/> Check to make sure the unit is plugged in. <input type="checkbox"/> Check the fuse/breaker or motor overload. <input type="checkbox"/> Reset the shop/house breaker and determine why the problem happened. <input type="checkbox"/> Take the compressor to a service center. <input type="checkbox"/> The compressor will turn on when the tank pressure drops to cut-in. <input type="checkbox"/> Check the voltage from the outlet. <input type="checkbox"/> The outside air or room temperature is too high. <input type="checkbox"/> The extension cord is too long or wrong gauge wire used.
The motor hums but cannot run or runs slowly.	<ul style="list-style-type: none"> <input type="checkbox"/> The voltage is low. <input type="checkbox"/> Wrong gauge wire or length of extension cord. <input type="checkbox"/> There is shorted or open motor winding. <input type="checkbox"/> There is a defective check valve or unloader. 	<ul style="list-style-type: none"> <input type="checkbox"/> Call an electrician or check with meter. <input type="checkbox"/> Check for proper gauge wire and cord length. <input type="checkbox"/> Take the compressor to a service center. <input type="checkbox"/> Take the compressor to a service center. <input type="checkbox"/> Remove the extension cord and plug directly into the wall outlet. If the issue is corrected, refer to chart on page 4 for proper gauge and length extension cords.
The fuses blow/circuit breaker trips repeatedly.	<ul style="list-style-type: none"> <input type="checkbox"/> The fuse size is incorrect, or there is a circuit overload. <input type="checkbox"/> Wrong gauge wire or length of extension cord. <input type="checkbox"/> There is a defective check valve or unloader. 	<ul style="list-style-type: none"> <input type="checkbox"/> Check for proper fuse, use a time-delay fuse, disconnect other electrical appliances from the circuit or operate the compressor on its own branch circuit. <input type="checkbox"/> Check for proper gauge wire and cord length. <input type="checkbox"/> Take the compressor to a service center.
The Push Button Overload protector cuts out repeatedly.	<ul style="list-style-type: none"> <input type="checkbox"/> The voltage is low. <input type="checkbox"/> There is a lack of proper ventilation or the room temperature is too high. <input type="checkbox"/> Wrong gauge wire or length of extension cord. 	<ul style="list-style-type: none"> <input type="checkbox"/> Call an electrician or check with meter. <input type="checkbox"/> Move the compressor to a well-ventilated area. <input type="checkbox"/> Check for proper gauge wire and cord length.
The air receiver pressure drops when the compressor shuts off.	<ul style="list-style-type: none"> <input type="checkbox"/> There are loose connections (fittings, tubing, etc.) <input type="checkbox"/> The drain valve is loose. <input type="checkbox"/> The check valve is leaking. 	<ul style="list-style-type: none"> <input type="checkbox"/> Check all connections with a soap and water solution and tighten. <input type="checkbox"/> Tighten the drain valve. <input type="checkbox"/> Take the compressor to a service center.
There is excessive moisture in the discharge air.	<ul style="list-style-type: none"> <input type="checkbox"/> There is excessive water in the air tank. <input type="checkbox"/> The humidity is high. 	<ul style="list-style-type: none"> <input type="checkbox"/> Drain the tank. <input type="checkbox"/> Move to an area with less humidity and use an airline filler.
The compressor runs continuously.	<ul style="list-style-type: none"> <input type="checkbox"/> There is a defective pressure switch. <input type="checkbox"/> There is excessive air usage. 	<ul style="list-style-type: none"> <input type="checkbox"/> Take the compressor to a service center. <input type="checkbox"/> Decrease air usage. The compressor is not large enough for tool's requirement.
The compressor vibrates.	<ul style="list-style-type: none"> <input type="checkbox"/> There are loose mounting bolts. 	<ul style="list-style-type: none"> <input type="checkbox"/> Tighten the mounting bolts.
The air output is lower than normal.	<ul style="list-style-type: none"> <input type="checkbox"/> There are broken inlet valves. <input type="checkbox"/> The connections are leaking. 	<ul style="list-style-type: none"> <input type="checkbox"/> Take the compressor to a service center. <input type="checkbox"/> Tighten connections.

Service Parts

EXPLODED VIEW

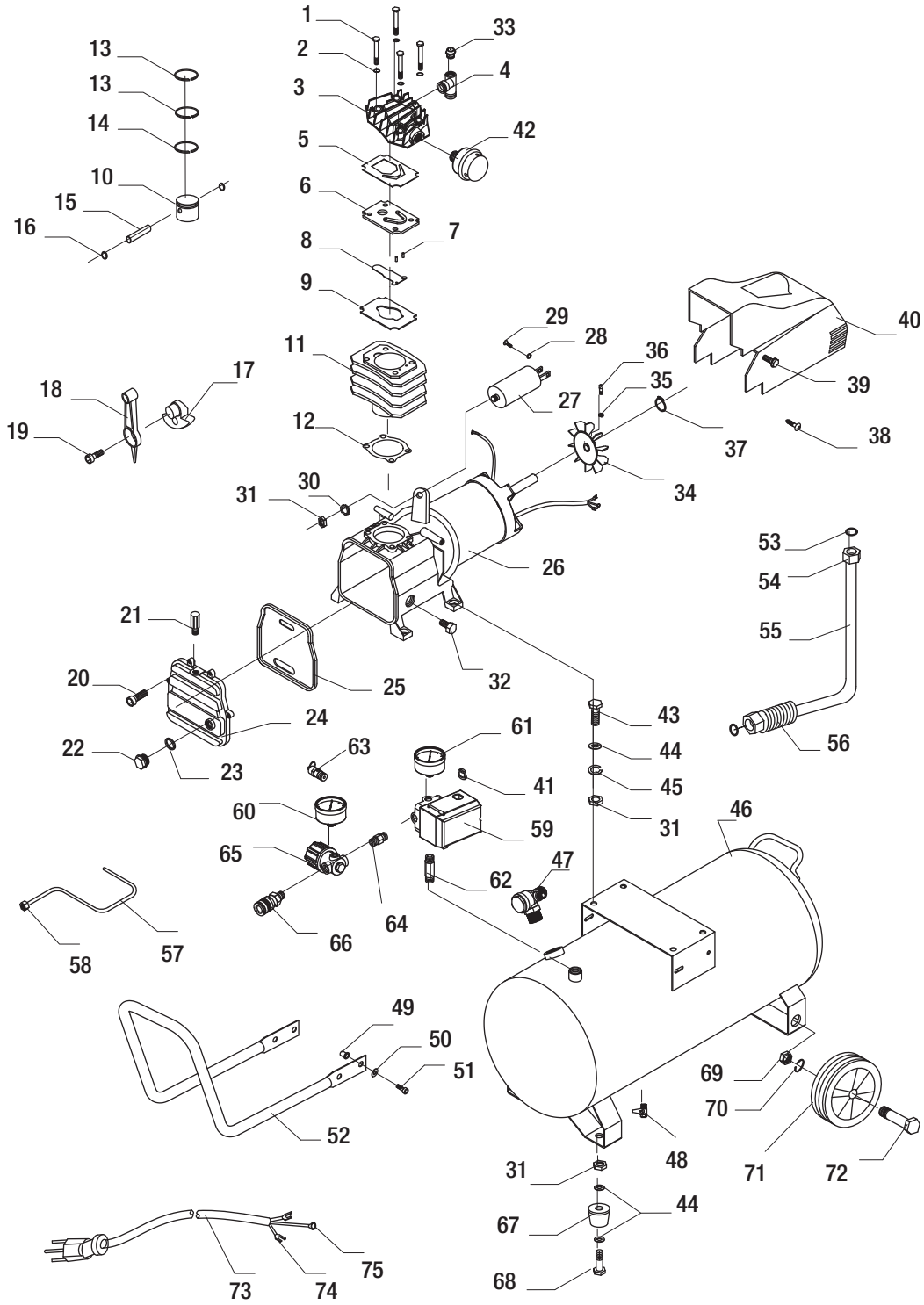

Service Parts (continued)

PARTS TABLE

Part	Description	Kit #	Part #	Qty
1	Head bolt, M80×105			4
2	Washer, lock 8 mm			4
3	Cylinder head		03-100	1
4	Fitting, tee		40-033	1
5	Gasket head	C	35-060	1
6	Valve, Assy.	B	11-004	1
7	Pin, dia. 3×6 mm	B		2
8	Valve, reed, inlet	B	34-001B	1
9	Gasket, cylinder upper	C	35-061	1
10	Piston	A	28-012	1
11	Cylinder		10-004	1
12	Gasket, Cylinder lower	C	35-062	1
13	Ring, compression	A	29-021	2
14	Ring, scraper	A		1
15	Pin, piston dia. 12 mm	A	30-003	1
16	Ring, snap 12 mm	A	46-005	2
17	Eccentric	A	12-004	1
18	Rod, connecting	A	03-032	1
19	Bolt, SHCS, M8×22-LH	A	45-154	1
20	Bolt, SHCS, M5×0.8×15			6
21	Oil fill cap M16×1.5		26-004C	1
22	Oil sight gauge	D	33-002	1
23	Seal, oil sight gauge	D		1
24	Cover, crankcase		03-101B	1
25	Baffle, rubber		36-015	1
26	Motor, assy.			1
27	Capacitor, running, 120 μ F		27-031	1
28	Washer, lock 3 mm			2
29	Screw, M3×6			2
30	Washer, tooth lock, 8 mm			1
31	Nut, M8×1.25	K		7
32	Plug, oil, M12×16		45-051B	1
33	Valve, relief		40-018B	1
34	Fan, AL alloy		03-109	1
35	Nut, M6			1
36	Bolt, SHCS, M6×16			1
37	Ring, snap. 14 mm			1
38	Screw, ST4. 2×12			2

Part	Description	Kit #	Part #	Qty.
39	Screw, with washer, M5×512			2
40	Shroud		06-063	1
41	Strain relief 6W-3		21-040	2
42	Air filter		41-005	1
43	Bolt, hex head, M8×30			4
44	Washer, flat, 8 mm	K		12
45	Washer, lock, 8 mm			4
46	Tank, 8 gal.			1
47	Check valve		38-001A	1
48	Drain valve, 1/4 in. NPT		39-020A	1
49	Nut, rivet, M6	E	45-086	4
50	Washer, flat, 6 mm			4
51	Screw, SHCH, M6×20			4
52	Handle	E	08-108B	1
53	Washer, flat, copper, 10 mm	F	46-029	2
54	Nut, hex, compression, G3/8	F	44-003	2
55	Tube, outlet, OD10 mm	F	43-017C	1
56	Fin, ID 10 mm	F		1
57	Tube, relief OD 6 mm	G	43-017F	1
58	Nut, hex, compression, G1/8	G	44-001A	1
59	Switch, pressure, 95-125 PSI		21-011A	1
60	Pressure gauge, 200 PSI, 1/8 in. NPT		23-018	1
61	Pressure gauge, 200 PSI, 1/4 in. NPT		23-038	1
62	Nipple, 1/4 in. NPT×48 mm		42-028	1
63	Valve, safety, 140 PSI, ASME, 1/4 in. NPT		24-010	1
64	Nipple, 1/4 in. NPT×30 mm		42-026E	1
65	Regulator, 1/8 in. NPT×1/4 in. NPT		25-053	1
66	Quick connect, one-touch, 1/4 in. NPT		42-080	1
67	Isolator, rubber	K	15-014	2
68	Bolt, hex head. M8×20	K		2
69	Nut, hex head, M10	H		2
70	Washer, lock, 10 mm	H		2
71	Wheel 6 in.	H	15-070	2
72	Shoulder bolt, OD15,5×36.5×M10	H	46-041	2
73	Cord, power, SJT14/3	I	22-005	1
74	Terminal, Y type 1.5-40	I		2
75	Terminal, O type 1.5-40	I		1

* Items with a kit number are only available as part of a kit. Items without a part number or kit letter are not available.



Questions, problems, missing parts? Before returning to the store,
call Husky Customer Service
8 a.m. - 6 p.m., EST, Monday-Friday

1-888-43-HUSKY

HUSKYTOOLS.COM

Retain this manual for future use.

Free Manuals Download Website

<http://myh66.com>

<http://usermanuals.us>

<http://www.somanuals.com>

<http://www.4manuals.cc>

<http://www.manual-lib.com>

<http://www.404manual.com>

<http://www.luxmanual.com>

<http://aubethermostatmanual.com>

Golf course search by state

<http://golfingnear.com>

Email search by domain

<http://emailbydomain.com>

Auto manuals search

<http://auto.somanuals.com>

TV manuals search

<http://tv.somanuals.com>