

JetStar® JetStar® JetStar® JetStar®

# JetStar® POPCORN MACHINE

MODELS

JR4

## Installation and Operation Instructions

2M-Z4430 Rev.G 11/07/12



JR4



## SAFETY SYMBOL



These symbols are intended to alert the user to the presence of important operating and maintenance instructions in the manual accompanying the appliance.

---

## RETAIN THIS MANUAL FOR FUTURE REFERENCE NOTICE

Using any part other than genuine Star factory supplied parts relieves the manufacturer of all liability.

Star reserves the right to change specifications and product design without notice. Such revisions do not entitle the buyer to corresponding changes, improvements, additions or replacements for previously purchased equipment.

Due to periodic changes in designs, methods, procedures, policies and regulations, the specifications contained in this sheet are subject to change without notice. While Star International Holdings Inc., Company exercises good faith efforts to provide information that is accurate, we are not responsible for errors or omissions in information provided or conclusions reached as a result of using the specifications. By using the information provided, the user assumes all risks in connection with such use.

## MAINTENANCE AND REPAIRS

Contact your local authorized service agent for service or required maintenance.

Please record the model number, serial number, voltage and purchase date in the area below and have it ready when you call to ensure a faster service.

Model No. \_\_\_\_\_  
Serial No. \_\_\_\_\_  
Voltage \_\_\_\_\_  
Purchase Date \_\_\_\_\_

### Authorized Service Agent Listing

Reference the listing provided with the unit

or

for an updated listing go to:

**Website:** [www.star-mfg.com](http://www.star-mfg.com)  
**E-mail** [Service@star-mfg.com](mailto:Service@star-mfg.com)

### Service Help Desk

**Business Hours:** 8:00 am to 4:30 p.m. Central Standard Time

**Telephone:** (314) 678-6303

**Fax:** (314) 781-2714

**E-mail** [Parts@star-mfg.com](mailto:Parts@star-mfg.com)  
[Service@star-mfg.com](mailto:Service@star-mfg.com)  
[Warranty@star-mfg.com](mailto:Warranty@star-mfg.com)

**Website:** [www.star-mfg.com](http://www.star-mfg.com)

**Mailing Address:** Star International Holdings Inc., Company  
10 Sunnen Drive  
St. Louis, MO 63143  
U.S.A

## SPECIFICATIONS:

### J4R SERIES

Capacity:	115 one ounce servings per hour
Electrical:	120 volt, 60 hertz, single phase, 1130 watts, 9.4 amps 230 volt, 50/60 hertz, single phase, 1130 watts, 4.9 amps Cord Length - 6 ft. Plug NEMA Spec - NEMA 5-15P (120V Models) CEE7-7 (230V Models)
Dimensions:	15-7/8" W x 14-7/8" D x 23-3/4" H (40.3 cm W x 37.8 cm D x 60 cm H)

---



### CAUTION

Before using your new equipment, read and understand all the instructions & labels associated with the unit prior to putting it into operation. Make sure all people associated with its use understand the units operation & safety before they use the unit.

All shipping containers should be checked for freight damage both visible and concealed. This unit has been tested and carefully packaged to insure delivery of your unit in perfect condition. If equipment is received in damaged condition, either apparent or concealed, a claim must be made with the delivering carrier.

Concealed damage or loss - if damage or loss is not apparent until after equipment is unpacked, a request for inspection of concealed damage must be made with carrier within 15 days. Be certain to retain all contents plus external and internal packaging materials for inspection. The carrier will make an inspection and will supply necessary claim forms.

## IMPORTANT SAFEGUARDS

When using electrical appliances, basic safety precautions should always be followed, including the following:

1. Read and follow all instructions.
2. Do not touch hot surfaces. Use handles or knobs.
3. To protect against electric shock do not immerse cord, plugs, or any part of the machine in water or other liquid.
4. Close supervision is necessary when any appliance is used by or near children.
5. Unplug from outlet when not in use and before cleaning. Allow to cool before putting on or taking off parts, and before cleaning the appliance.
6. Do not operate any appliance with a damaged cord or plug or after the appliance malfunctions, or has been damaged in any manner. Contact the nearest Star authorized service center for repair or the delivering carrier for damages (visible or concealed).
7. The use of accessory attachments not recommended by the appliance manufacturer may cause injuries.
8. Do not use outdoors.
9. Do not let cord hang over edge of table or counter, or touch hot surfaces.
10. Do not place on or near a hot gas or electric burner, or in a heated oven.
11. **DO NOT** move an appliance containing hot oil or other hot liquids.
12. To disconnect, turn all controls to "off," (I) = on, (O) = off, then remove plug from wall outlet.
13. Do not use appliance for other than intended use.
14. "A popper that is plugged into an outlet should not be left unattended."
15. "This popper will not shut off automatically. To avoid overheating, add corn and oil before operating." - *See General Operating Instructions for more information.*
16. "Extreme caution must be used when unloading popcorn as the popcorn and the machine will be extremely hot."
17. **SAVE THESE INSTRUCTIONS.**

## INSTALLATION

Each machine has been properly wired and inspected at the factory for operation on the voltage and type of current specified on the nameplate.



### CAUTION:

**DO NOT CONNECT TO ANY OTHER TYPE OF CURRENT OR THE MACHINE WILL BE SERIOUSLY DAMAGED.**

#### 120 VOLT MACHINES

Machines with a nameplate stamped 120V, are equipped for operation on 120 volt 60 hertz AC single phase service and must be connected to a 3 wire grounded, polarized receptacle.

#### 230 VOLT MACHINES

Machines with a nameplate stamped 230V, are equipped for operation on 230 volt 50 hertz AC single phase service and must be connected to a 3 wire grounded receptacle. Customer must supply own light bulb rated 230V and 50W maximum.

## GENERAL OPERATING INSTRUCTIONS

With all switches in the "OFF" (0) position, proceed in the following sequence to pop corn:

1. Turn "ON" (1) the light switch.
2. Turn "ON" (1) the kettle switch. Allow six or seven minutes to pre-heat the kettle. Thermostat adjustments should not be necessary as it has been preset at the factory for the correct popping temperature.
3. A corn and oil measuring cup is supplied with your machine. Pour an 1/8 cup measuring cup of oil (one ounce) in kettle, add 2 level 1/4 cup measuring cups (1/2 cup) of raw corn and 1/4 to 1/2 teaspoon of popcorn salt. Vary the amount of salt and oil to suit taste. If desired, salt may be added after the corn is popped.  
**or**  
Our Recommended corn is "Chiefs Choice" available with coconut oil in 4 oz portion packs from your local Star dealer.
4. When the corn stops popping, dump the kettle immediately by turning the handle clockwise approximately 90 degrees to release latch. Latch and load immediately if more popping is desired. Do not leave the kettle switch "on" (1) unless continuously popping corn. Results will vary with different oils and popcorn varieties.
5. Turn the kettle switch "off" (0) when the desired amount of popping is completed.



### CAUTION:

**DO NOT LEAVE THE KETTLE SWITCH "ON" (1) WHEN THE MACHINE IS NOT IN USE.**

**DO NOT IMMERSE KETTLE IN WATER OR ALLOW WATER TO COME IN CONTACT WITH THE HEATING ELEMENT.**

**POPPING CORN IN DRY KETTLE IS NOT RECOMMENDED.**

## MAINTENANCE

### KEEPING THE POPPING UNIT CLEAN

After each popping period, wipe the inside and outside of the kettle while it is warm (not hot) with a clean cloth. This is important to keep salt and seasoning from forming a carbonized material which not only lowers popping efficiency but can cause excessive smoking or damage the kettle. Use a damp cloth and a warm mild soap solution to clean the clear plastic surfaces.

### THOROUGHLY INSPECT YOUR UNIT ON ARRIVAL

This unit has been tested for proper operation before leaving our plant to insure delivery of your unit in perfect condition. However, there are instances in which the unit may be damaged in transit. In the event you discover any type of damage to your product upon receipt, you must immediately contact the transportation company who delivered the item to you and initiate your claim with same. If this procedure is not followed, it may affect the warranty status of the unit.

### LIMITED EQUIPMENT WARRANTY

All workmanship and material in Star products have a one (1) year limited warranty on parts & labor in the United States and Canada. Such warranty is limited to the original purchaser only and shall be effective from the date the equipment is placed in service. Star's obligation under this warranty is limited to the repair of defects without charge, by the factory authorized service agency or one of its sub-agencies. Models that are considered portable (*see below*) should be taken to the closest Star service agency, transportation prepaid.

- > Star will not assume any responsibility for loss of revenue.
- > On all shipments outside the United States and Canada, see International Warranty.
- \* The warranty period for the Ultra-Max, Hot Plates, Griddles, Charbroilers is (3) years parts & labor.
- \* The warranty period for the Star-Max, Charbroilers, Griddles, Hot Plates, Fryers & Finishing Oven is (2) years parts & labor.
- \* The warranty period for the JetStar six (6) ounce & Super JetStar eight (8) ounce series popcorn machines is two (2) years.
- \* The warranty period for the Chrome-Max Griddles is five (5) years on the griddle surface. See detailed warranty provided with unit.
- \* The warranty period for Teflon/Dura-Tec coatings is one year under normal use and reasonable care. This warranty does not apply if damage occurs to Teflon/Dura-Tec coatings from improper cleaning, maintenance, use of metallic utensils, or abrasive cleaners, abrasive pads, product identifiers and point-of-sale attachments, or any other non-food object that comes in continuous contact with the roller coating. This warranty does not apply to the "non-stick" properties of such materials.
- > This warranty does not apply to "Special Products" but to regular catalog items only. Star's warranty on "Special Products" is six (6) months on parts and ninety (90) days on labor.
- > This warranty does not apply to any item that is disassembled or tampered with for any purpose other than repair by a Star Authorized Service Center or the Service Center's sub-agency.
- > This warranty does not apply if damage occurs from improper installation, misuse, wrong voltage, wrong gas or operated contrary to the Installation and Operating instructions.
- > This warranty is not valid on Conveyor Ovens *unless* a "start-up/check-out" has been performed by a Factory Authorized Technician.

### PARTS WARRANTY

Parts that are sold to repair out of warranty equipment are warranted for ninety (90) days. The part only is warranted, the labor to replace the part is **NOT** warranted.

### SERVICES NOT COVERED BY WARRANTY

1. Travel time and mileage rendered beyond the 50 mile radius limit
2. Mileage and travel time on portable equipment (*see below*)
3. Labor to replace such items that can be replaced easily during a daily cleaning routine, ie; removable kettles on fryers, knobs, grease drawers on griddles, etc.
4. Installation of equipment
5. Damages due to improper installation
6. Damages from abuse or misuse
7. Operated contrary to the Operating and Installation Instructions
8. Cleaning of equipment
9. Seasoning of griddle plates
10. Voltage conversions
11. Gas conversions
12. Pilot light adjustment
13. Miscellaneous adjustments
14. Thermostat calibration and by-pass adjustment
15. Resetting of circuit breakers or safety controls or reset buttons
16. Replacement of bulbs
17. Replacement of fuses
18. Repair of damage created during transit, delivery, & installation OR created by acts of God

### PORTABLE EQUIPMENT

Star will not honor service bills that include travel time and mileage charges for servicing any products considered "Portable" including items listed below. These products should be taken to the Service Agency for repair:

- \* The Model 510FD, 510FF Fryer.
- \* The Model 526TOA Toaster Oven.
- \* The Model J4R, 4 oz. Popcorn Machine.
- \* The Model 518CMA & 526CMA Cheese Melter.
- \* The Model 12MC & 15MC & 18MCP Hot Food Merchandisers.
- \* The Model 12NCPW & 15NCPW Nacho Chip/Popcorn Warmer.
- \* All Hot Dog Equipment **except Roller Grills & Drawer Bun Warmers.**
- \* All Nacho Cheese Warmers **except Model 11WLA Series Nacho Cheese Warmer.**
- \* All Condiment Dispensers **except the Model HPD & SPD Series Dispenser.**
- \* All Specialty Food Warmers **except Model 130R, 11RW Series, and 11WSA Series.**
- \* All QCS/RCS Series Toasters **except Model QCS3 & RCS3 Series.**
- \* All Fast Steamer Models **except Direct Connect Series.**

### ALL:

- \* Pop-Up Toasters
- \* Butter Dispensers
- \* Pretzel Merchandisers (Model 16PD-A Only)
- \* Pastry Display Cabinets
- \* Nacho Chip Merchandisers
- \* Accessories of any kind
- \* Sneeze Guards
- \* Pizza Ovens (Model PO12 Only)
- \* Heat Lamps
- \* Pumps-Manual

The foregoing warranty is in lieu of any and all other warranties expressed or implied and constitutes the entire warranty.

### FOR ASSISTANCE

Should you need any assistance regarding the Operation or Maintenance of any Star equipment; write, phone, fax or email our Service Department. In all correspondence mention the Model number and the Serial number of your unit, and the voltage or type of gas you are using.

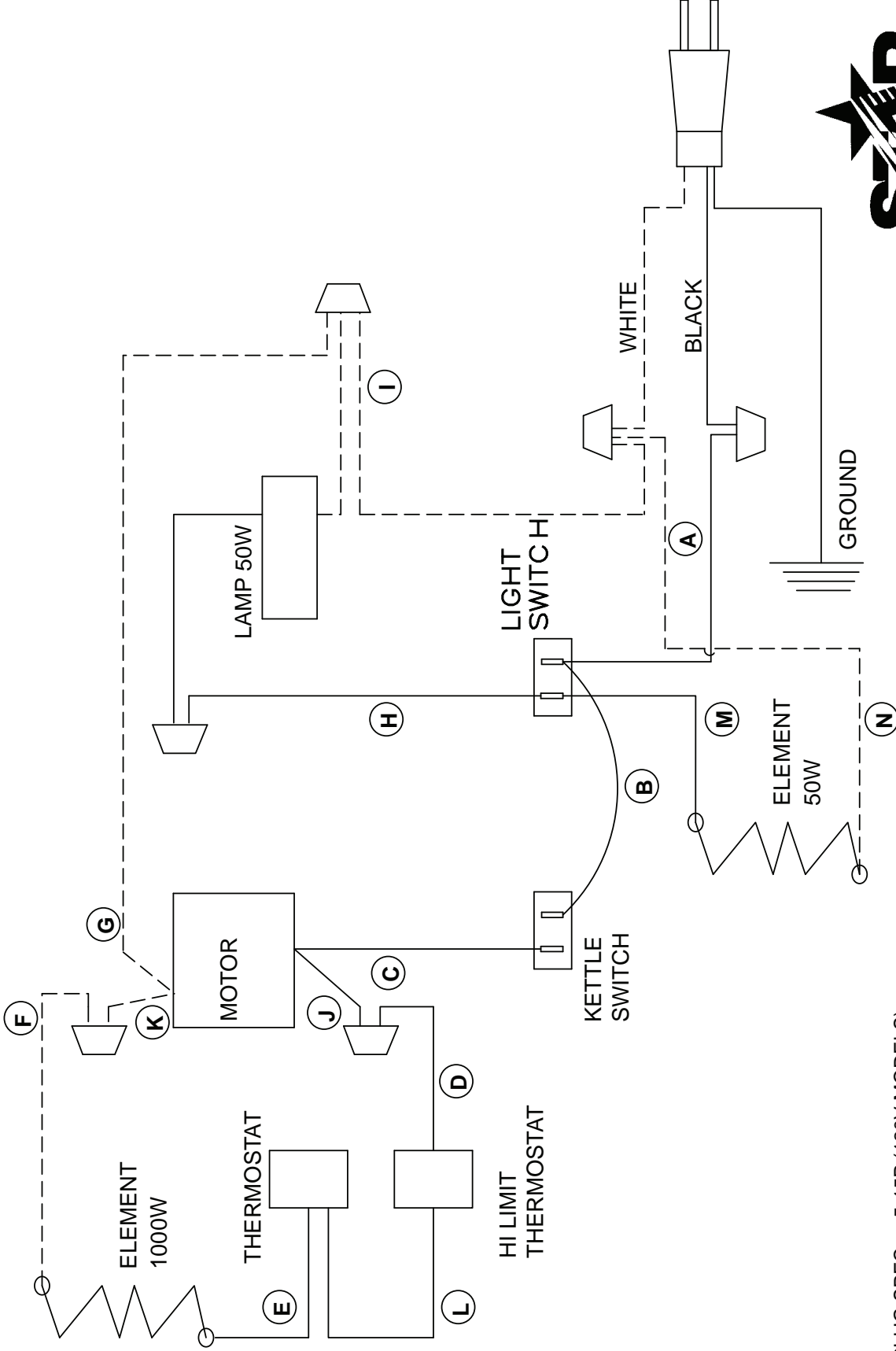

PLUG SPEC: 5-15P (120V MODELS)  
CEE7-7 (230V MODELS)

**MODEL: J4R**

THIS DRAWING CONTAINS INFORMATION CONFIDENTIAL TO STAR MFG. INT'L. INC.  
NO REPRODUCTION OR DISCLOSURE OF ITS CONTENTS IS PERMITTED.



**STAR MANUFACTURING INTERNATIONAL INC.**

SK1860

Rev B

10/08/2001

# J4R

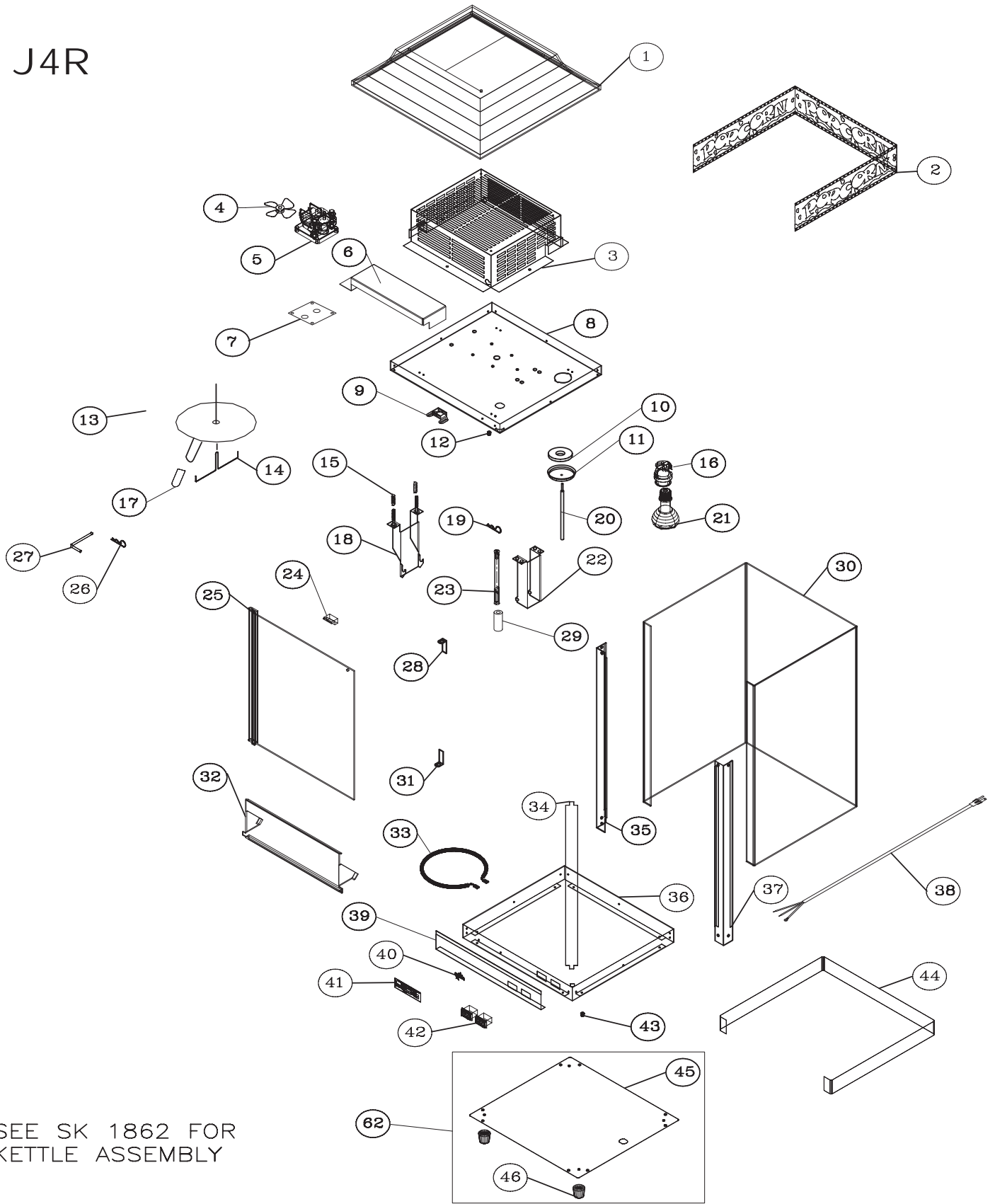

SEE SK 1862 FOR  
KETTLE ASSEMBLY

STAR MANUFACTURING INTERNATIONAL  
SK 1861 REV. 07-27-01



J4R

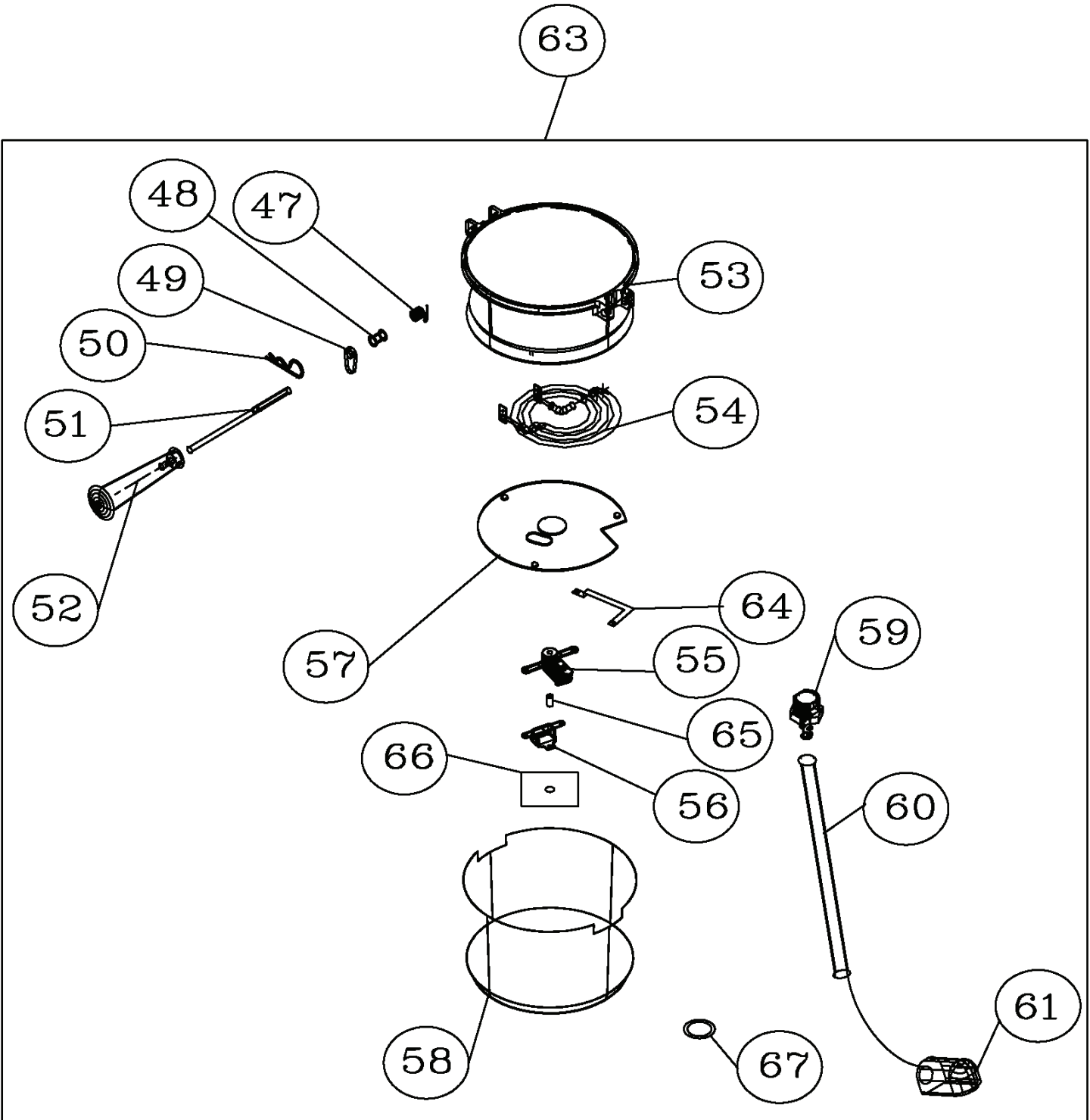

SEE SK 1861 FOR  
J4R ASSEMBLY

STAR MANUFACTURING INTERNATIONAL

J4R REV. A SK 1862 11-14-01 DWG. SDO

# PARTS LIST

November 07, 2012, Rev. G

MODELS J4R 4 OZ. POPCORN POPPER

Key Number	Part Number	Number Per Unit	Description
1	2L-Z4372	1	Top
2	2M-Z4368	1	Sign Display
3	C3-Z4940	1	Top Enclosure
4	2R-Y4810	1	Fan 3" Plastic
5	PS-4P1012	1	2U-Y6914 J4R 120V MTR KIT
	2U-Y6926	1	Motor-240V
6	C3-Z4964	1	Wire Housing
7	2I-Y6709	1	Motor Cushion
8	C3-4P1008	1	Topliner
9	2C-9788	1	Magnetic Catch
10	2R-Y7229	1	Magnet
11	C3-Y7230	1	Cup-Magnet
12, 43	2K-Z4317	2	Bushing SB-375
13	2D-4P1000	1	Kettle Cover Assembly
14	2B-Z4383	1	Blade Agitator
15	2P-Y6918	2	Spring Latch
16	2E-Y5921	1	Socket
17	2R-Y7571	1	Cover Tab
18	2D-4P1004	1	Kettle Latch Assembly
19	2A-Y6694	1	Hair Pin
20	2A-Z4466	1	Guide Cover
21	2S-Z4465	1	Lamp (130V Tuff Bond, 50 W) Lamp (230V) Not Available
22	2D-Z4380	1	Hinge Bracket
23	2A-Z4382	1	Shaft-Agitator
24	C3-Y7475	1	Pull Door
25	C3-4P1005	1	Door and Hinge Assembly
26	2A-Y6694	1	Hair Pin
27	2A-Y4595	1	Pin Hinge Plated
28	C3-Y7446	1	Bracket Hinge Right
29	2A-Z4384	1	Collar-Agitator
30	C3-Z4371	1	Body
31	C3-Y7377	1	Bracket Hinge Left
32	C3-4P1006	1	Lower Door
33	2N-Y4306	1	Element 50W 120V
	2N-Z3781	1	Element 50W 240V
34	C3-Z4379	1	Wire Cover
35	C3-Z4429	1	Corner Post Left
36	C3-4P1007	1	Bottom
37	C3-Z4428	1	Corner Post Right
38	A5-250027	1	Lead-In Cord
	C3-39221	1	Lead-In Cord 230V

**IMPORTANT: WHEN ORDERING, SPECIFY VOLTAGE OR TYPE GAS DESIRED  
INCLUDE MODEL AND SERIAL NUMBER**

PAGE 1  
OF 2

Some items are included for illustrative purposes only and in certain instances may not be available.



**Star Manufacturing International, Inc.**

# PARTS LIST

November 07, 2012, Rev. G

MODELS J4R 4 OZ. POPCORN POPPER

Key Number	Part Number	Number Per Unit	Description
39	C3-Z4852	1	Front Panel
40	2M-Z2718	1	Star Emblem
41	C3-Z4431	1	Nameplate
	C3-Z4992	1	Nameplate 230V
42	2E-Z0091	2	Switch
44	C3-Z4459	1	Bottom Wrap
45	C3-Z4375	1	Bottom Panel
46	2I-Z0057	4	Foot Rubber
47	2P-Z4619	1	Spring Handle
48	2A-Y6142	1	Sleeve Handle
49	C3-Y5378	1	Cam
50	2B-Y6139	1	Clip-Handle
51	2A-Z4525	1	Rod-Handle
52	2R-Y7381	1	Handle-Kettle
53	2F-Z4386	1	Kettle, Aluminum
54	2N-Z4418	1	Element 1000W 120V
	2N-Z4991	1	Element 1000W 230V
55	2T-Z4524	1	Thermostat BI-MET 510
56	2T-Y9419	1	Thermostat, High Limit
57	2D-Z4446	1	Element Plate
58	2D-Z4387	1	Kettle Shell
59	2E-Z1520	1	3/8 Connector Conduit
60	2E-8355	1	Conduit Kettle
61	2E-1177	1	Connector 3/8 TB #266
62	PS-4P1009	1	Bottom Panel Assy
63	C3-4P1002	1	Kettle Assy Complete 120V
	C3-4P1010	1	Kettle Assy Complete 230V
64	E1-7363	1	Clamp
65	C3-Z5078	1	Spacer
66	C3-Z5079	1	Insulation Pad
67	2E-Y4967	1	Washer
NI	2L-Y4639	1	1/4 Cup Measuring Cup
NI	2L-Y4916	1	RED Popcorn Scoop
NI	2E-Z4440	1	Wire Kit
NI	2M-Z4861	1	Decal - Switches

**IMPORTANT: WHEN ORDERING, SPECIFY VOLTAGE OR TYPE GAS DESIRED  
INCLUDE MODEL AND SERIAL NUMBER**

PAGE 2  
OF 2

Some items are included for illustrative purposes only and in certain instances may not be available.



**Star Manufacturing International, Inc.**

STAR INTERNATIONAL HOLDINGS INC. COMPANY  
Star - Holman - Lang - Wells - Bloomfield - Toastmaster  
10 Sunnen Drive, St. Louis, MO 63143 U.S.A.  
(314) 678-6303  
[www.star-mfg.com](http://www.star-mfg.com)

## Free Manuals Download Website

<http://myh66.com>

<http://usermanuals.us>

<http://www.somanuals.com>

<http://www.4manuals.cc>

<http://www.manual-lib.com>

<http://www.404manual.com>

<http://www.luxmanual.com>

<http://aubethermostatmanual.com>

Golf course search by state

<http://golfingnear.com>

Email search by domain

<http://emailbydomain.com>

Auto manuals search

<http://auto.somanuals.com>

TV manuals search

<http://tv.somanuals.com>