

OWNER'S MANUAL

MODEL NO.

UltraFilter 300
625.384720

UltraFilter 500
625.384750

Caution:
Read and Follow
All Safety Rules and
Operating Instructions
Before First Use of
This Product.

If you have questions when
installing, operating or
maintaining your reverse
osmosis system, call this
toll-free number...

1-800-426-9345

www.KenmoreWater.com

SAVE THIS MANUAL

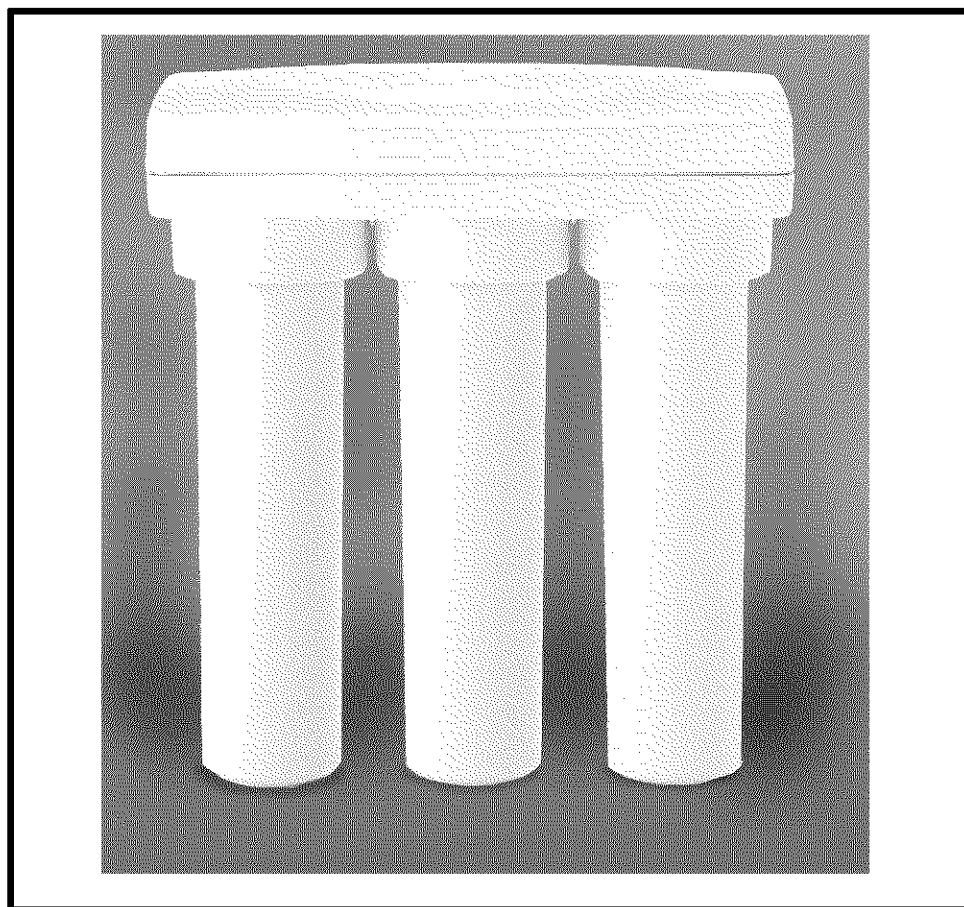

Reverse Osmosis Drinking Water System

- ◆ Warranty
- ◆ How To Install
- ◆ How It Works
- ◆ Care Of
- ◆ Repair Parts

System tested and certified by NSF International
to ANSI/NSF Standard 58 for the reduction of the
claims specified on the performance data sheet.



Sears, Roebuck and Co., Hoffman Estates, IL 60179 U. S. A.

Part No. 7227352 (Rev. L 10/21/03)

– WARRANTY –

FULL WARRANTY ON REVERSE OSMOSIS DRINKING WATER SYSTEM (except filter cartridges and R. O. membrane)

For one year from the date of purchase, when the Reverse Osmosis Drinking Water System is installed and maintained in accordance with our instructions, Sears will repair, free of charge, defects in material and workmanship, except filter cartridges and the R. O. membrane.

TO OBTAIN WARRANTY SERVICE, SIMPLY CONTACT THE NEAREST SEARS SERVICE CENTER THROUGHOUT THE UNITED STATES. This warranty applies only while this product is in use in the United States.

This warranty gives you specific legal rights, and you may have other rights which vary from state to state.

Sears, Roebuck and Co., D/817 WA, Hoffman Estates, IL 60179

SEARS INSTALLATION POLICY

All installation labor arranged by Sears shall be performed in a neat, workmanlike manner in accordance with generally accepted trade practices. Further, all installations shall comply with all local laws, codes, regulations, and ordinances. Customer shall also be protected during installation by insurance relating to Property Damage, Workman's Compensation and Public Liability.

SEARS INSTALLATION WARRANTY

In addition to any warranty extended to you on the Sears merchandise involved, which warranty becomes effective the date the merchandise is installed, should the workmanship of any Sears arranged installation prove faulty within one year, Sears will, upon notice from you, cause such faults to be corrected at no additional cost to you.

– SAFETY GUIDES –

▼ Read all steps and guides carefully before installing and using your reverse osmosis system. Follow all steps exactly to correctly install. Reading this manual will also help you to get all the benefits from the reverse osmosis system.

▼ Do not attempt to use this product to make safe drinking water from non-potable water sources. Do not use the system on microbiologically unsafe water, or water of unknown quality without adequate disinfection before or after the system. This system is certified for cyst reduction and may be used on disinfected water that may contain filterable cysts.

▼ Check with your local public works department for plumbing and sanitation codes. You must follow their guides as you install the system. Follow your local codes if they differ with guides in this manual.

▼ This system shall only be used for arsenic reduction on chlorinated water supplies containing detectable residual free chlorine at the system inlet. Water systems using an inline chlorinator should provide a one minute chlorine contact time before the RO system.

▼ This system is acceptable for treatment of influent concentrations of no more than 27 mg/L nitrate and 3 mg/L nitrite in combination measured as N and is certified for nitrate/nitrite reduction only for water supplies with a pressure of 280 kPa (40 psig) or greater.

▼ The reverse osmosis system works on water pressures of 40 psi (minimum) to 100 psi (maximum). If your house water pressure is over the maximum, install a pressure reducing valve in the water supply pipe to the reverse osmosis system.

▼ Do not install the reverse osmosis system outside, or in extreme hot or cold temperatures. Temperature of the water supply to the reverse osmosis system must be between 40°F and 100°F. Do not install on hot water.

▼ Read the other limits (pH, hardness, etc.) in the specifications and be sure your water supply conforms. Also see "Water Supply" on page 3.

▼ The reverse osmosis membrane contains a preservative for storage and shipment. Be sure to purge as instructed on page 9 before using product water.

– TABLE OF CONTENTS –

Where To Install the RO System	4	Installation Steps - continued
Tools and Materials Needed	4	Sanitizing, Pressure Test, Purging
Installation Steps	5-9	9
Cold Water Supply	5	How the RO System Works
Drain Adapter	6	10-11
Faucet	6-7	Care of RO System
RO Assembly	7	12-15
Storage Tank, Tubing Connections	8	Dimensions, Specifications
		16
		Remote Installation Locations
		17
		Repair Parts
		18-19

– WHAT YOUR REVERSE OSMOSIS SYSTEM WILL DO –

Your Reverse Osmosis (RO) Drinking Water System is a water treatment unit. It uses household water pressure to reverse a natural physical process called *osmosis*. Water, under pressure, is forced through a semi-permeable membrane where minerals and impurities are filtered out. Clean drinking water goes to the faucet or storage, while minerals and impurities are sent to the drain with RO waste water. The minerals and impurities are measured in water as *total dissolved solids* (TDS).

The system includes replaceable pre and postfilter sediment-carbon cartridges. The prefilter removes sand, silt, dirt, rust particles, other sediments, and chlorine from the water supply before it can enter the

RO membrane. The postfilter removes any tastes and/or odors that may remain in the water, after passing through the RO membrane, and just before going to the RO faucet. To prevent water waste, an automatic shutoff valve closes when the RO faucet is closed and the storage tank is full.

Your reverse osmosis system gives you a continuous supply of sparkling clear, delicious water for drinking, cooking and other uses. Foods will look and taste better too. Having high quality RO product water at your fingertips eliminates the need to buy bottled water. The storage tank holds over 2 gallons of RO product water for your needs.

– BEFORE YOU BEGIN TO INSTALL THE RO SYSTEM –

FOR OPTIMUM PERFORMANCE YOUR KENMORE REVERSE OSMOSIS SYSTEM SHOULD BE INSTALLED ON SOFTENED WATER.

CAUTION: A refrigerator icemaker may not operate properly when connected to a reverse osmosis system that has been installed on a water system that operates outside of the specified pressures listed on page 16.

Check Your Water Supply: The *cold* water supply to the RO system must be within certain quality limits. See the specification table on page 16. If supply water is not within limits, the RO system can not make product water as it should and reduced RO membrane life will result.

Trained sales people at Sears can arrange for a free water analysis. The analysis will tell you if other water supply treatment is needed before going to the RO system.

CAUTION: Chlorine in the water will destroy the RO membrane. Most cities add chlorine to the water supply to kill bacteria. The prefilter removes chlorine up to the limits shown in the specifications before it enters the RO membrane. It is **important**

to replace the prefilter cartridge at least every 6 months. See the RO care guide on page 16.

Check Parts Included: Unpack the carton and remove the RO system. In addition to the assembled RO and the storage tank, the system includes the parts illustrated below, a separate length of tubing, and this manual.

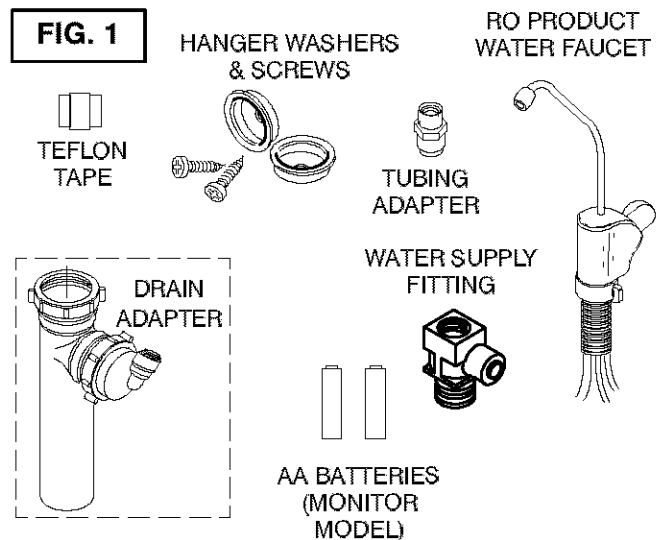

– WHERE TO INSTALL THE RO SYSTEM –

The RO assembly and storage tank is designed for installation under the sink, usually in the kitchen or bathroom. The RO assembly mounts on a wall surface, or can lay on the cabinet floor next to the storage tank. Hanger washers and wood screws are included for cabinet wall mounting. The RO product water faucet installs on the sink, or on the countertop next to the sink (pages 6 and 7).

Note: Tubing lengths allow for the removal of the assembly from the hanger washers for servicing. If tubing lengths are shortened for neater appearance, it may be necessary to keep the assembly on the hanger washers for service.

You can also locate the RO assembly and storage tank

in any **remote location** from the faucet, observing safety guides on page 2. You do need a nearby water source and drain point (see page 17).

Water Supply: To provide supply water to the RO system inlet use the included feed supply fitting or install pipe fittings for tubing connection, as typically shown on page 5.

Drain Point: A suitable drain point is needed for reject water from the RO membrane. A floor drain, laundry tub, standpipe, sump, etc., is preferred, as shown in the remote locations drawing, page 17. A sink p-trap drain adaptor is included to install where codes permit, as an optional drain point (page 6).

FIG. 2

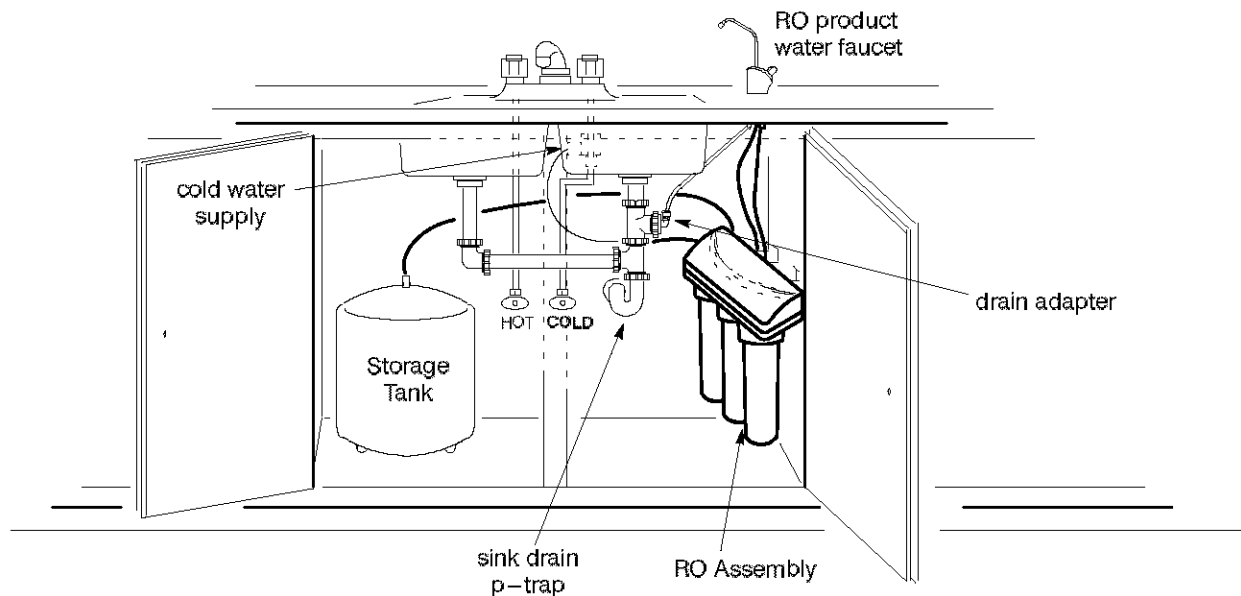

– TOOLS AND MATERIALS NEEDED –

- ▶ adjustable wrench, standard pliers, and larger adjustable jaw pliers or pipe wrench to fit sink drain
- ▶ electric drill and bits, if hole is needed for the RO faucet, page 6 and 7
- ▶ slotted and Phillips head screwdrivers
- ▶ plumbers putty

– 6 STEPS TO INSTALL –

STEP 1: - Install Cold Water Supply fittings - page 5

STEP 2: - Install Drain Adapter - page 6

STEP 3: - Install Faucet - pages 6 and 7

STEP 4: - Install RO Assembly - page 7

STEP 5: - Install Storage Tank, Make Remaining Tubing Connections - page 8

STEP 6: - Sanitizing, Pressure Testing, Purging - page 9

- STEP 1: INSTALL COLD WATER SUPPLY FITTING -

Check and comply with local plumbing codes as you plan, then install a cold feed (supply) water fitting. The fitting must provide a leak-tight connection to the RO 1/4" tubing (see FIG. 8, page 8). A typical connection using the included water supply fitting is shown in FIG.3 - A below. An optional connection, using standard plumbing fittings (not included), is shown in B.

Note: Codes in the state of Massachusetts require installation by a licensed plumber, and do not permit the use of a saddle valve. For installation, use plumbing code 248-CMR of the Commonwealth of Massachusetts.

A. WATER SUPPLY FITTING

1. Close the house main water shutoff valve and open faucets to drain water from the sink cold water pipe.
2. Remove nut that connects the cold water faucet to cold water plumbing.
3. Use pipe joint compound or Teflon tape on cold water faucet stud threads and on the male threads of the water supply fitting that connect to the cold water pipe.
4. Thread water supply fitting onto pipe and reconnect nut to bottom of fitting.

B. OPTIONAL PIPE FITTINGS (compression type shown)

Note: Be sure to turn off the water supply and open a low faucet to drain the pipe.

Complying with plumbing codes, install a fitting on the kitchen cold water pipe to adapt 1/4" OD tubing. A typical connection is shown in figure 3B. If threaded fittings are used, be sure to use pipe joint compound or Teflon tape on outside threads.

FIG. 3

A. WATER SUPPLY CONNECTION
(using included water supply fitting)

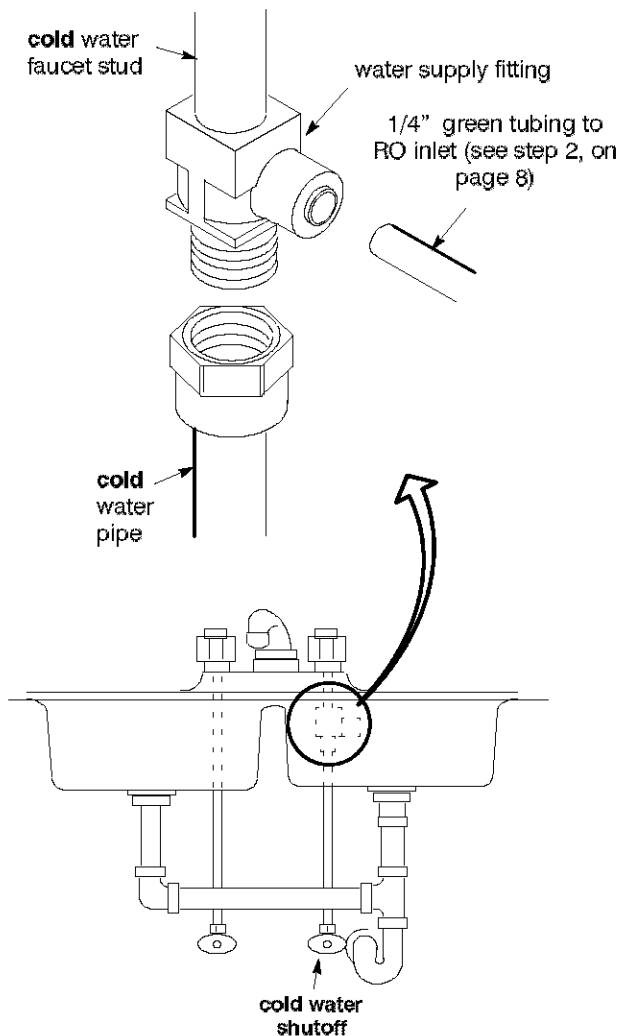

B. WATER SUPPLY TYPICAL CONNECTION
(using compression fitting)

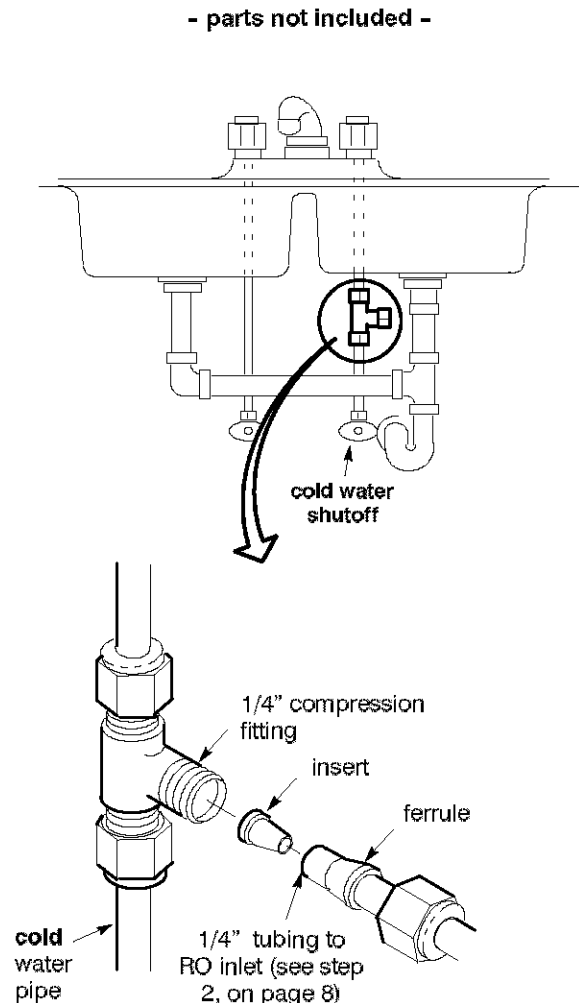

– STEP 2: INSTALL DRAIN ADAPTER –

■ **Note:** Running the drain tubing directly to a floor drain, sump, standpipe, laundry tub, etc., as shown on page 17, is preferred. However, if that is not possible or practical, the included drain adapter installs in the sink drain pipe, always **above** or ahead of the p-trap (FIG. 4). **Be sure to comply with your local plumbing codes.** Other drain pipe fittings, in addition to the adapter, may be needed.

■ The drain adapter fits 1-1/2" sink drain pipe.

■ The adapter installs directly onto the sink tailpiece as typically shown in FIG. 4 and 5.

■ Locate so drain tubing from the faucet (installed in step 1, page 8) makes a straight run to the adapter, **without dips, loops, low spots or kinks.**

Note: Consult a plumber if you are not familiar with plumbing procedures.

1. Use a ferrule and nut to assemble the drain tubing connector to the drain adapter (FIG. 5). Turn the connector to about 45° from the 12:00 position, as shown (to 10:00 or 2:00 position as needed). Tighten the nut securely.

2. Carefully disassemble the sink drain pipe and clean the tailpiece to assure a leak-tight fit.

3. Install the drain adapter onto the sink tailpiece, using a ferrule and nut. Snug the nut, but do not tighten.

Note: If needed, to make fit, you can cut to shorten the unthreaded end of the adapter. **Do not cut too short** so the adapter will make a leak-tight seal with the connecting fitting.

4. Assemble the p-trap to the drain adapter, and other drain pipe fittings as required (check codes) to complete the drain run.

5. Tighten all connections, but do not overtighten and break plastic fittings.

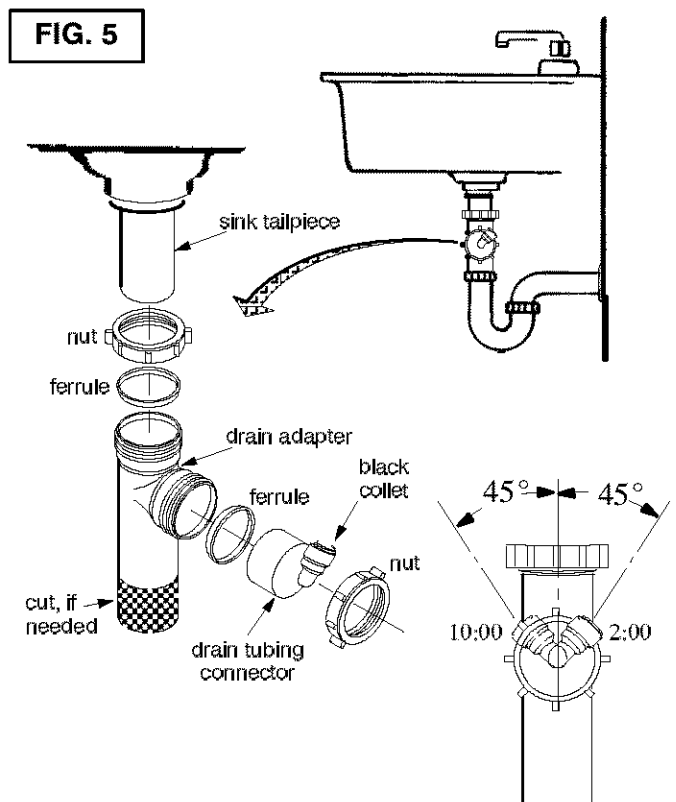
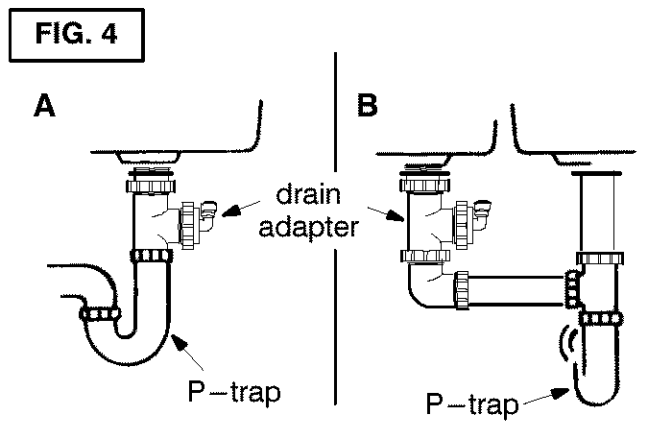

– STEP 3: INSTALL FAUCET –

A. PREPARE MOUNTING HOLE

1. Select one of the following places for the faucet. Be sure it will fit flat against the surface, and there is space underneath for tubing (see FIG. 8, page 8).

◆ Use an existing sink top hole for a spray hose or other faucet. **A 1-1/8" to 1-1/4" diameter hole is needed.**

◆ Drill a new hole in the countertop next to the sink.

◆ Drill a new hole in the sink top.

CAUTION: To avoid damaging a sink beyond repair, consult a qualified plumber or installer for guides to drill holes in porcelain or stainless steel.

2. If drilling is needed, make the 1-1/8" to 1-1/4" diameter hole.

3. Place plumbers putty around the drilled hole (FIG. 6) to prevent water leakage around the base of the faucet.

– STEP 3: INSTALL FAUCET (cont.) –

B. ASSEMBLE FAUCET

1. Remove the large blue nut from the faucet threads.
2. Slide the three attached tubes and the telephone style wire (monitored models only) through the sink or countertop hole, aligning gasket under faucet base.
3. On the underside of the sink or countertop, screw the nut on the faucet threads with the tubing and wire running through the center hole of the nut. **Tighten the nut so the faucet cannot move, but do not overtighten.**

4. CONNECT TUBING TO FAUCET AS FOLLOWS.

a. Using the 3/8" x 1/4" tubing adaptor, connect the 1/4" blue tubing from the faucet to the 3/8" blue tubing from the RO.

Note: See pages 13 and 14 for tubing connection instructions.

b. Using the 1/4" x 1/4" tubing adaptor, connect the 1/4" red tubing from the faucet to the 1/4" red tubing from the RO.

c. Monitored models only: Connect the telephone style wire to the receptacle on PWA board in the RO manifold and route the wiring through holes in top cover and manifold assembly.

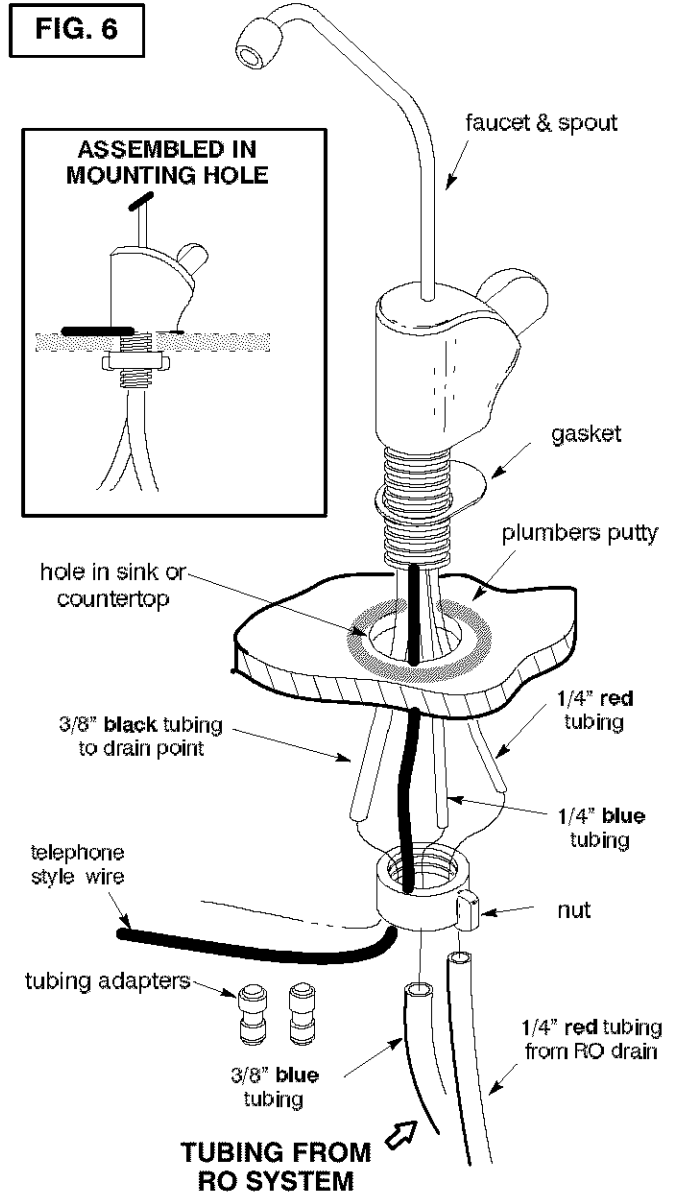

– STEP 4: INSTALL RO ASSEMBLY –

Hang the assembly on the included hanger washers, or lay on the cabinet floor, as desired.

1. Refer to FIG. 7 for wall mounting. Hold the assembly up to the wall surface and mark locations for the hanger washers. Distance needed is 7.2" (approx. 7-7/32") apart.

2. Install hanger washers at least 15-1/2" up from the cabinet floor, allowing room to remove sumps from filter heads. Wood screws are provided, or obtain other fasteners as needed.

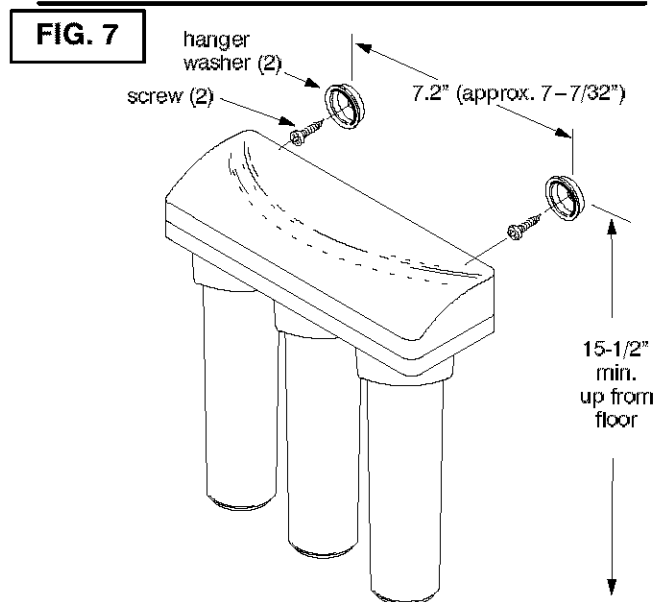

– STEP 5: INSTALL STORAGE TANK, MAKE REMAINING TUBING CONNECTIONS –

1. **CONNECT DRAIN TUBING, FAUCET TO DRAIN ADAPTER:** Referring to FIG. 8, run the loose section of **black 3/8"** tubing from the faucet to the drain adapter, with a black collet, installed on page 6. Cut this tubing as needed to **route in as straight of a run as possible, without loops, dips, low spots or kinks.** Cut the end of the tubing square. Then push all the way into the fitting. Pull on the tubing to be sure it's held firmly in the adapter fitting. See pages 13 and 14 for tubing connection instructions.

2. **CONNECT TUBING TO WATER SUPPLY:** Connect the feed (green) tube to the water supply fitting installed on page 5. Connection to the fitting is as de-

scribed in Fig. 11, page 14.

3. Move the storage tank into place next to the RO assembly. You can stand the tank upright, or lay it on side. Apply no more than two wraps of Teflon tape to the threads on the nipple at the top of the tank. Hand tighten the other included tubing adapter fitting with the yellow collet onto the tank nipple, then wrench 1/4 turn only. **BE CAREFUL NOT TO CROSS THREAD.**

4. Run the 3/8" **yellow** tubing to the fitting installed in step 3. Be sure the end of the tubing is cut square, and insert all the way into the fitting. Again, pull on the tubing to be sure it's held firmly in the fitting.

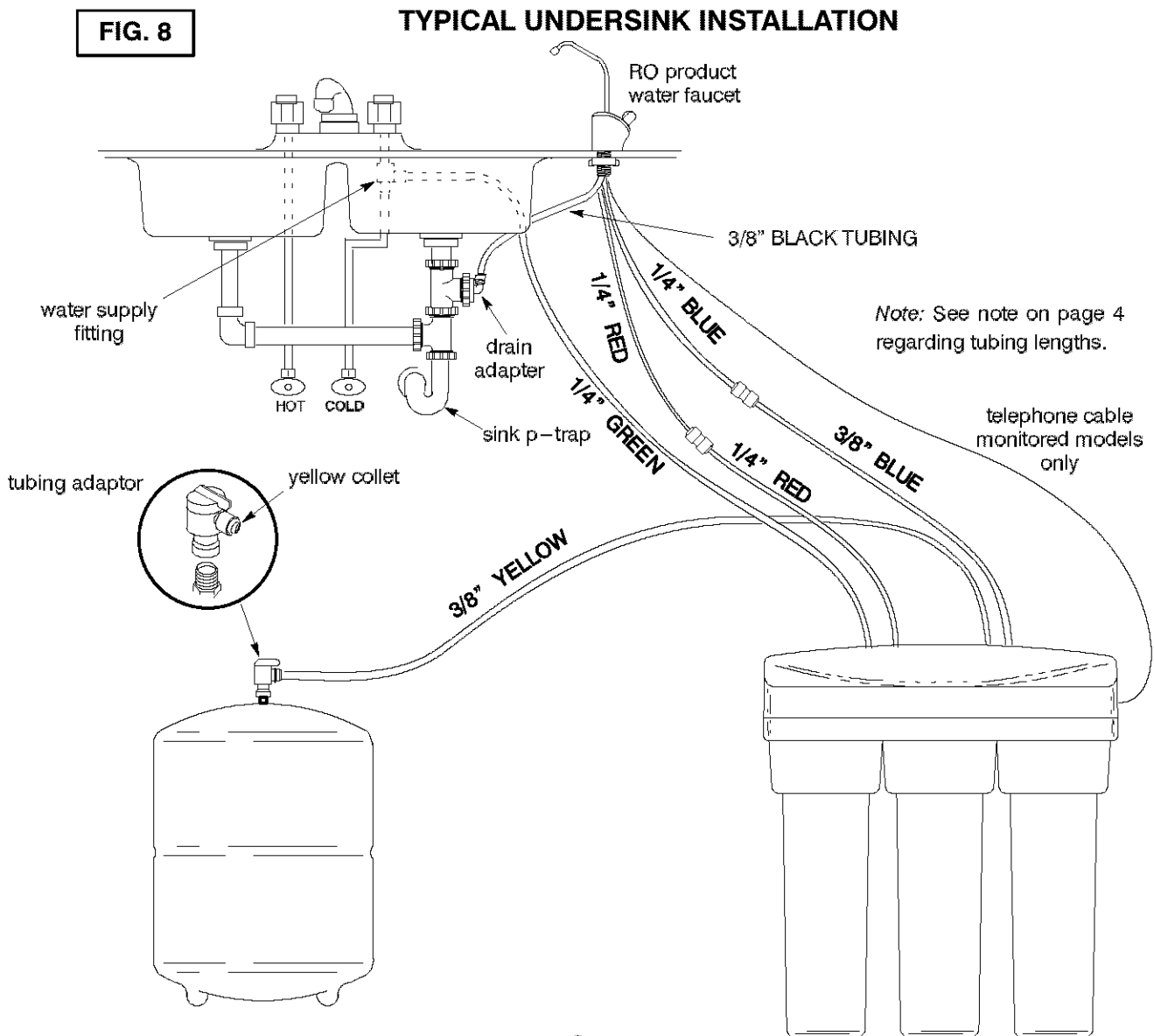

– STEP 6: SANITIZING, PRESSURE TESTING & PURGING –

SANITIZING

Sanitizing is recommended upon installation of the RO system, and after servicing inner parts. **It is important for the service person to have clean hands while handling inner parts of the system.**

CAUTION: Be sure to remove the RO membrane and both filter cartridges as follows, before sanitizing. *Chlorine will destroy the RO membrane cartridge.*

1. Be sure the **water supply to the RO is turned off**, and the **RO faucet is open** to relieve pressure.
2. Referring to FIG. 9, page 12, remove the RO membrane sump by twisting 1/4 turn left (↺). Remove the RO cartridge from sump. Place the cartridge in a **clean** plastic bag.
3. Be sure the o-ring seal is on the sump. Replace the RO sump by turning to the right (↻) to lock.
4. Remove the postfilter sump, turning to the left. Take the cartridge from the sump and place in the plastic bag. Replace the sump by turning to the right (↻) to lock.
5. Remove the prefilter sump and cartridge. Also place this cartridge in the clean bag.

6. If needed to clean, flush the prefilter sump with fresh water. Then fill with water to about 1" from the top. Add 1.0 ounce of chlorine (ordinary 5.25% household bleach...Hilex, Clorox, etc.) and mix in the water. **Do not add chlorine first.** Concentrated it will attack plastics.

7. Carefully replace the sump on the prefilter head and turn to the right (↻) to lock.
8. Slowly open the water supply to the RO.
9. Open the RO faucet by turning knob to the left.
10. Allow water to circulate through the RO system until you smell the bleach odor at the faucet. Then close the faucet and allow the RO to stand idle for 20 minutes.
11. After the 20 minutes open the RO faucet and run water until the bleach odor is gone.
12. Turn off the water supply to the RO.
13. **Be sure your hands are clean.** Then, repeat steps 1 - 5 and 7, only **replace all cartridges.**

Important: Refer to FIG. 9, page 12, and to page 13 when replacing cartridges. The prefilter (left side) cartridge and the postfilter (right side) have purple end caps.

PRESSURE TESTING

1. **Do the preceding sanitizing procedures before pressure testing.**
2. Open the water supply shutoff valve to the RO.
3. Open the **main** water supply valve and several house faucets to purge air from the system. Close faucets when water runs smooth.

4. *In about 2 hours*, pressure will start to build in the RO system. **Then**, carefully check all fittings and connections for water leaks. Correct leaks if any are found.

Note: When the system is first pressurized, water may "spurt" from the faucet airgap hole until air is expelled from the RO system.

PURGING RO MEMBRANE

Important purging instructions: The RO cartridge contains a *food grade preservative* that should be removed before using water from the system. The preservative will give product water an unpleasant taste and odor.

1. Allow the storage tank to fill for about 4 hours. Then open the RO faucet until the tank is empty and flow stops.
2. Close the RO faucet and allow the tank to fill again for 4 hours. Then open the RO faucet and empty again.

Repeat steps 1 and 2 to purge the storage tank 6 times. Then the RO system is ready to make product water for use.

– HOW YOUR REVERSE OSMOSIS SYSTEM WORKS –

PREFILTER

Water from the cold supply pipe enters the RO assembly prefilter first (FIG. 8, page 8, and schematic, page 11).

The prefilter has a replaceable sediment cartridge with activated carbon in its composition. The cartridge (10 micron) removes sand, silt, dirt, other sediments, and up to the ppm of chlorine shown in the specifications from the feed water (page 16). **Chlorine will destroy the RO membrane.** Filtered, clean, chlorine-free water flows from the prefilter, to the RO membrane cartridge.

IMPORTANT: See prefilter maintenance, page 12.

REVERSE OSMOSIS (RO) CARTRIDGE

The RO cartridge is a tightly wound special membrane. The membrane removes the dissolved solids and organic matter when water is forced through the cartridge. High quality product water (about one ounce per minute) exits the RO cartridge and goes to the storage tank, or to the postfilter and RO faucet. Reject water, with the dissolved solids and organic matter, is routed through the flow control and to the drain.

STORAGE TANK

The storage tank holds up to 2.3 gallons of product water. A diaphragm inside the tank keeps water pressurized to about 30 psi, when the tank is full, to provide fast flow to the RO faucet. The tank, when empty, is pressurized to 5 - 7 psi.

POST FILTER

After leaving the storage tank, but before going to the RO faucet, product water goes through the post filter. The post filter is an activated carbon type filter. Any remaining tastes and odors are removed from the product water. Taste-free, odor-free, clean, high quality drinking water is available for use.

FAUCET

The sink or countertop faucet has a hand operated knob to access drinking water. By turning the knob to the left opens the faucet, turning to the right shuts off the faucet.

To comply with plumbing codes, an air-gap is built into the faucet drain water connection.

FAUCET ELECTRONICS

The RO system will monitor the total product flow of the unit and also length of time the filters have been installed. The faucet base has an indicator light that

flashes to inform you of the status of the RO membrane and filters.

Green - RO membrane and filters are good. *Amber* - Warning, filters will need replacing shortly. Filters need replacing, when water has been drawn, after 182 days (or 750 gallons have been used). *Red* - RO membrane needs to be replaced.

When the two "AA" batteries are first applied at initial start up, the LED indicator light will flash in a red, amber, green sequence. All timers and counters are reset to zero.

In order to reset the monitor time and gallon count feature, the batteries should be removed for a minimum of five seconds and then reinserted.

Batteries need to be replaced once a year at the time of filter replacement. Do not mix battery types, use only "AA" alkaline batteries. Improper placement of batteries could damage electronics. Use care when inserting batteries to align them correctly in manifold with the proper polarity.

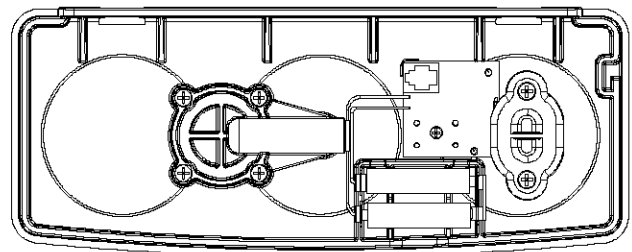

SHUTOFF ASSEMBLY

To conserve water, the drinking water system has an automatic shutoff system. When the storage tank has filled to capacity, *and* the drinking water faucet is closed, pressure closes the shutoff to stop flow to drain. Pressure in the storage tank is about half of the water supply pressure. After drinking water is used, and pressure in the system drops, the shutoff opens to allow water flow again.

CHECK VALVE

A check valve (FIG. 12) is located in the RO manifold, above the center sump. The check valve prevents a backward flow of product water from the storage tank. A backward flow could rupture the RO membrane.

FLOW CONTROL

Water flow through the RO membrane is regulated by the flow control. It maintains the desired flow rate to obtain the highest quality drinking water. The flow control is located in the end of the 1/4" red drain tubing, at the RO manifold drain port.

- HOW YOUR REVERSE OSMOSIS SYSTEM WORKS -

REVERSE OSMOSIS WATER FLOW SCHEMATIC

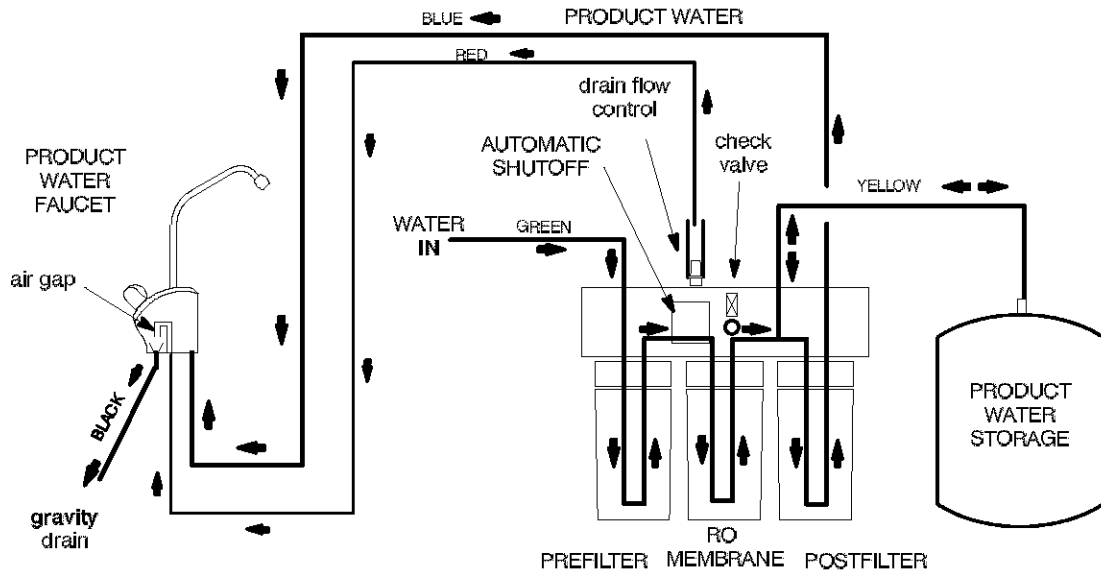

- CARE OF YOUR REVERSE OSMOSIS SYSTEM -

To keep your reverse osmosis system operating and producing high quality water, you must make sure supply water is always within the limits shown in the specifications. Good supply water helps to assure longer life from the RO membrane cartridge, prefilter and postfilter cartridges. However, each of these will wear out in time and need replacement.

This reverse osmosis system contains a replaceable treatment component critical for effective removal of total dissolved solids. The monitor faucet feature provides continuous analysis of the systems performance. For systems not equipped with the monitor faucet function, it is highly recommended that you have your water tested at least every 6 months to verify your system is performing properly. Test kits are available by calling 1-800-826-8553 ext. 47, or check the water testing section of your local phone directory.

If the RO assembly is wall mounted, you may be able to replace parts with the assembly left on the wall. If not, simply lift the RO assembly from the mounting washers and lay on the cabinet floor when replacing the prefilter and post filter cartridges and RO membrane.

Note: To prevent spillage, place a container under the RO assembly, or put the RO assembly in a container to catch the water.

CAUTION: Before disconnecting parts, be sure to close the *water supply valve* to the RO.

PREFILTER AND POST FILTER CARTRIDGES

You must replace the prefilter cartridge often to protect the RO membrane from being destroyed by chlorine, and / or from plugging with sediments in your water supply. If the water supply contains both chlorine and sediments, replace the prefilter cartridge at least every 6 months of product water use. Replace more often than 6 months if it begins to plug with sediments.

If the water has sediments only, with no chlorine, you may notice a slower making of product water as the prefilter collects the sediments. When this occurs, replace the prefilter cartridge. *Also replace the post filter cartridge.*

To replace the filter cartridges (see FIG. 9):

1. Turn off the water supply and open the RO faucet to relieve pressure.
2. Remove (turn to the left) both sumps from the filter heads. **Be careful** . . .the sumps are full of water.
3. Remove and discard the inner cartridges in a proper manner. Flush the insides of the sumps with fresh water. **Do not lose the large o-ring seals.**

4. Insert new cartridges with o-ring* seals towards the top, and with lubricated* o-rings in place, turn to the right to reattach the sumps.

5. Remove and replace batteries to reset counter and timer. (monitor models).

**Note:* Use a lubricant approved for use on a potable water supply.

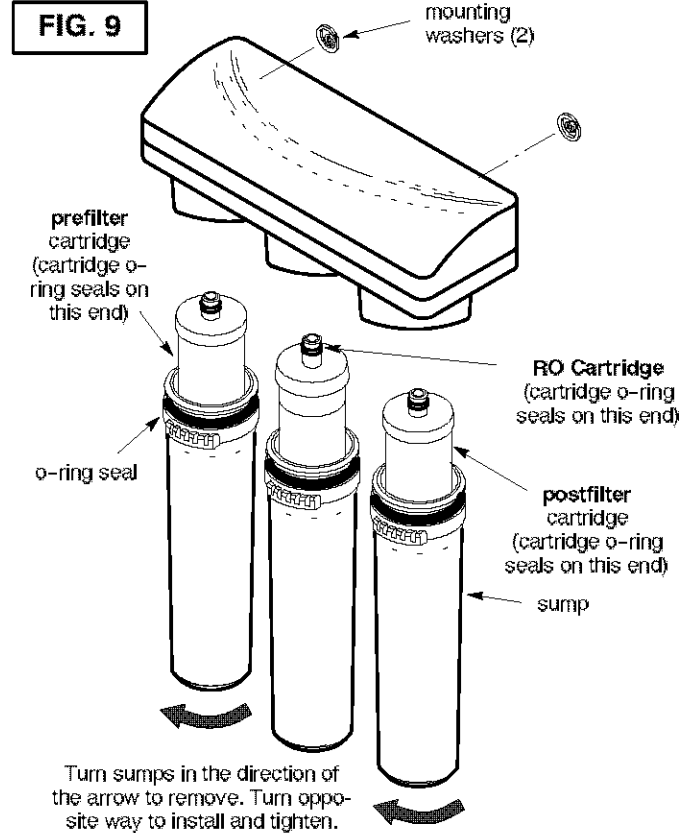

RO MEMBRANE CARTRIDGE

The life of the RO membrane cartridge depends mostly on the pH of the supply water to the RO system (see specifications). Cartridge life is shorter with higher pH. *For example, if supply water pH is from 6.8 to 7.7, the cartridge may last for well over one year. However, cartridge life may be as short as 6 months if the pH is as high as 8.5 to 10.* Higher pH weakens the cartridge membrane and causes pin-hole leaks.

It's time to replace the RO cartridge when the red LED flashes or the production rate and / or quality of product water drops. Product water may begin to taste different or bad, indicating solids and organics are passing through the RO membrane. To be sure it is the RO cartridge, replace the prefilter and postfilter cartridges first.

To replace the RO cartridge (see FIG. 9):

1. Turn off the water supply and open the RO faucet to relieve pressure.

continued

– CARE OF YOUR REVERSE OSMOSIS SYSTEM –

2. Remove (turn to the left) the sump from the filter head. **Be careful . . .the sump is full of water.**

3. Remove and discard the RO cartridge in a proper manner. Flush the insides of the sump with fresh water. **Do not lose the large o-ring seals.**

Note: Sanitizing is recommended after servicing inner parts of the system (see page 9).

4. Insert new RO cartridges with o-ring seals towards the top, and with lubricated o-ring in place, turn to the right to reattach the sump.

5. Remove and replace batteries to reset counter and timer. (monitor models).

6. *Purge the RO membrane cartridge following instructions on page 9.*

FLOW CONTROL

The flow control is vital for proper operation of the RO membrane cartridge. The control keeps water flow through the membrane at the needed rate to obtain the best quality product water.

Periodically check the flow control to be sure the small hole through it is clean and unrestricted.

FIG. 10

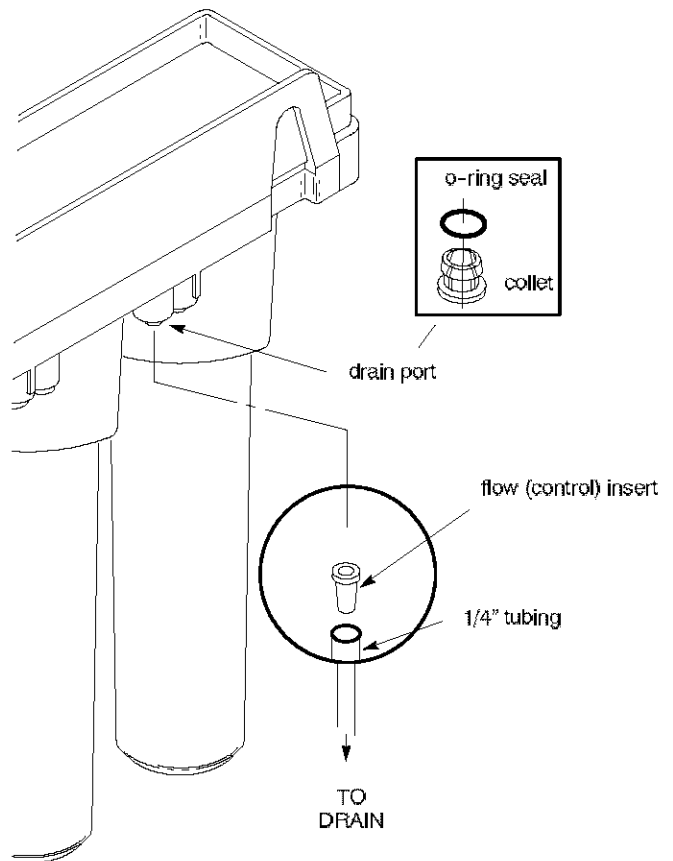

TUBING CONNECTION (all push-in fitting locations)

This RO system includes push-in fittings for quick tubing connection at most locations. If working with the fittings, do the following.

Connection (FIG. 11 - A):

1. Use a sharp cutter or knife to cut the end of tubing square.
2. Inspect the end (about 1") of the tubing to be sure there are no nicks, scratches or other rough spots. If needed, cut the tubing again.
3. Push tubing through the collet and all the way into fitting. Full engagement is 11/16" for 1/4" tubing, and 3/4" for 3/8" tubing.

If using tubing other than tubing supplied with the system, be sure it is of high quality, exact size and roundness with a smooth surface.

continued

- CARE OF YOUR REVERSE OSMOSIS SYSTEM -

TUBING CONNECTION (continued)

To Disconnect Tubing: Push the collet inward and hold with a finger while pulling the tubing out.

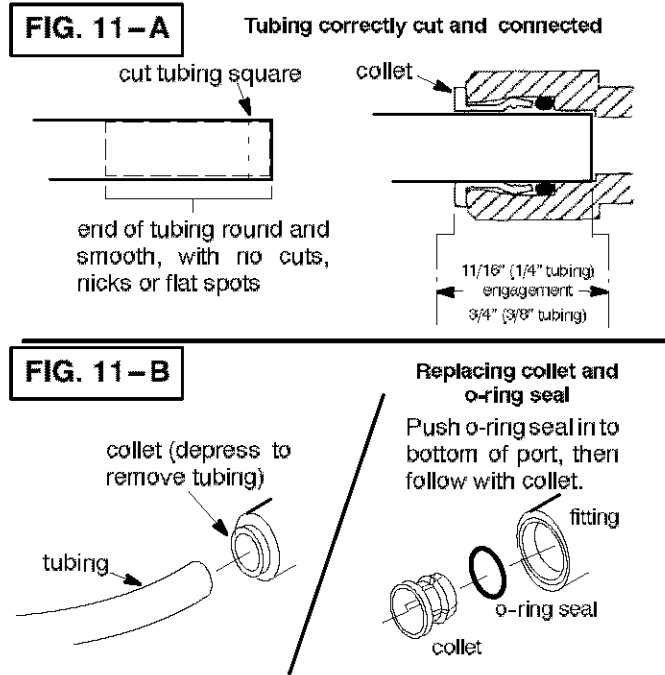

Changing Collet and O-ring (FIG. 11):

1. With a small screwdriver remove the collet and o-ring from the fitting. **Be careful not to scratch the internal walls of the collet port.**
2. Be sure the port is clean, then lubricate and insert the o-ring seal to the bottom of the port.
3. Push the collet inward until it locks in place.

CAUTION

DO NOT USE VINEGAR OR OTHER ACID BASED CLEANERS ON THIS RO SYSTEM. THEY WILL DEGRADE SOME RO SYSTEM PARTS. ALWAYS USE SOAP AND WATER.

This reverse osmosis system contains a replaceable treatment component critical for effective removal of total dissolved solids. The water should be tested periodically to verify the system is performing satisfactorily.

AUTOMATIC SHUTOFF SERVICE

If the shutoff assembly requires service, be sure to reassemble parts exactly as shown in FIG. 12.

FIG. 12

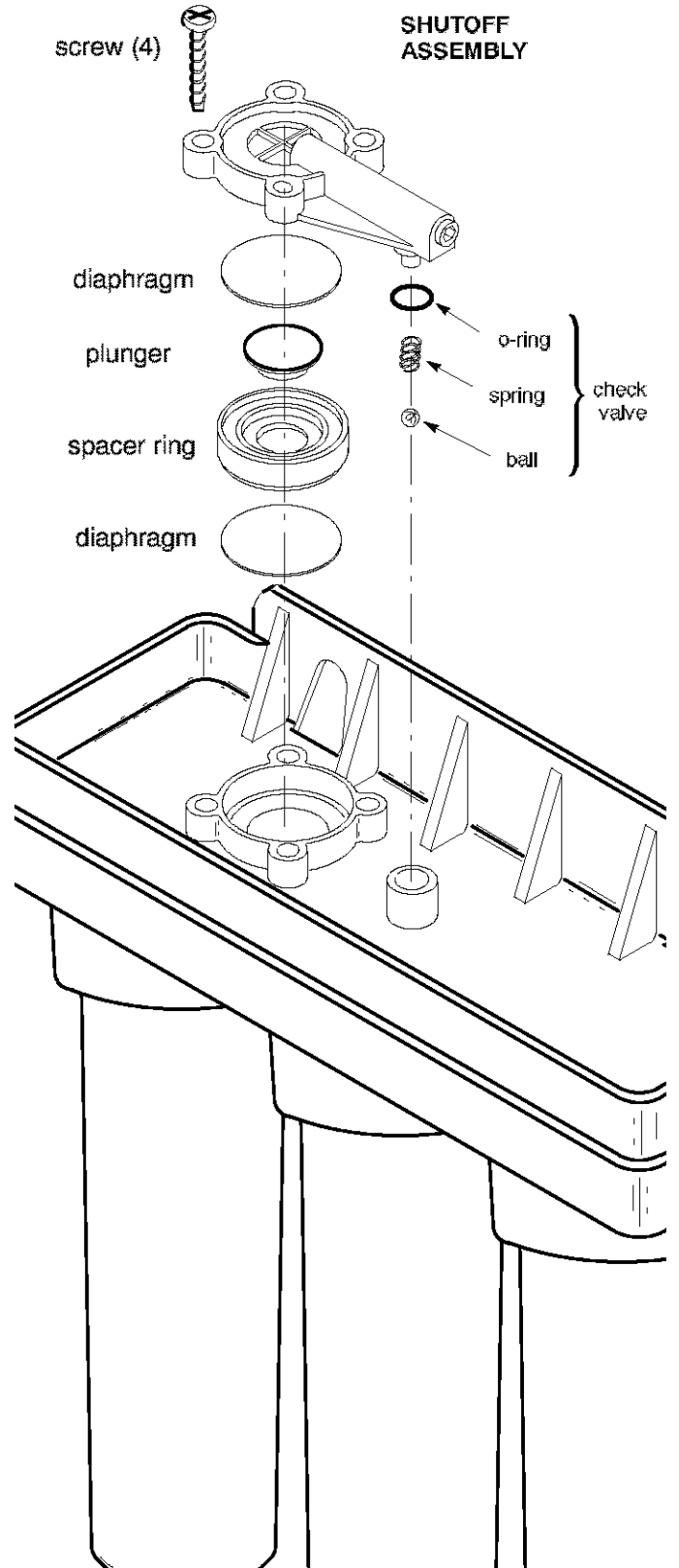

– CARE OF YOUR REVERSE OSMOSIS SYSTEM –

REVERSE OSMOSIS SYSTEM CARE GUIDE MODEL NOS. 625.384720 & 625.384750	
1. AT LEAST every 6 months, replace the prefilter and postfilter cartridges or when yellow LED flashes.	
2. Replace the RO membrane cartridge when the percent rejection of total dissolved solids (TDS) is less than shown in the specifications (see B , below) or when red LED flashes.	
3. Replace the batteries once per year.	
If any of the following occur before the 6 months, replace as directed.	
A. Slow Making of Product Water: Replace the prefilter cartridge. If the production rate does not improve, replace the post filter cartridge and RO membrane cartridge.	C. Chlorine Taste and/or Odor: Replace the prefilter, post filter and RO membrane cartridges.
B. High Total Dissolved Solids (TDS) in Product Water: You can get a free TDS test through some Sears retail stores or service departments. If the store or service department does not have a TDS meter, you can send treated and untreated water samples to a water analysis lab for testing. It is important to test both the treated and untreated water to determine system performance. If the TDS is not within the system's performance guidelines, replace the prefilter, post filter and RO membrane cartridges.	

OTHER TROUBLESHOOTING		
PROBLEM	CAUSE	CORRECTION
<i>Chlorine taste and/or odor in the RO product water</i>	The ppm of chlorine in your water supply exceeds maximum limits, and has destroyed the RO membrane.	If the water supply contains more than 2.0 ppm of chlorine, additional filtering of the water supply to the RO is needed. Correct this condition before doing maintenance on the RO system.
	The prefilter is no longer removing chlorine from the water supply.	Replace the prefilter, post filter and RO membrane cartridges.
<i>Other taste and/or odor</i>	Post filter expended.	Replace the post filter cartridge. If taste and odor persists, replace the prefilter cartridge and RO membrane cartridge.
	RO membrane cartridge expended.	
	Contamination in product water storage.	Use sanitizing procedures. Replace the post filter cartridge.
<i>System makes product water too slowly</i>	Water supply to the RO system not within specifications.	Increase water pressure, precondition the water, etc., as needed to conform before doing maintenance on the RO system.
	Prefilter or RO membrane cartridges plugged with sediments.	Replace the prefilter cartridge. If rate does not increase, replace the postfilter cartridge and RO membrane cartridge.
<i>System makes lower amount of product water than usual</i>	Storage tank air-charge less than 5 – 7 psi.	Open RO faucet and drain tank until flow slows to a drip. Keep faucet open and check tank pressure. If low, pressurize to 6 psi. Close faucet to refill the tank.
<i>High total dissolved solids (TDS) in product water – flashing red LED</i>	Water supply to the RO system not within specifications.	Increase water pressure, precondition the water, etc., as needed to conform before doing maintenance on the RO system.
	RO membrane cartridge expended.	Replace the prefilter, postfilter and RO membrane cartridges, flow control, and screen.
<i>Water leaking from faucet airgap hole</i>	Drain side of faucet airgap (3/8" tubing) plugged, restricted, or incorrectly connected to drain point.	Inspect and eliminate restriction or plug. Refer to installation instructions for proper drain connection.
<i>Continual water flow to drain</i>	Check valve or automatic shutoff assembly plugged, restricted or parts worn	Clean, repair or replace as needed.
<i>Faucet LED indicator light does not function after battery change</i>	Batteries dead.	Replace with new batteries.
	Batteries installed incorrectly.	Install batteries correctly.
	Static protection device was not discharged.	Remove batteries for a minimum of one hour and then reinstall.
<i>Continual water flow to drain and no product water</i>	Missing flow restrictor in red drain tube or its corresponding port.	Replace flow restrictor.

Note: Sanitizing is recommended after servicing inner parts of the system(see page 9).

– DIMENSIONS and SPECIFICATIONS –

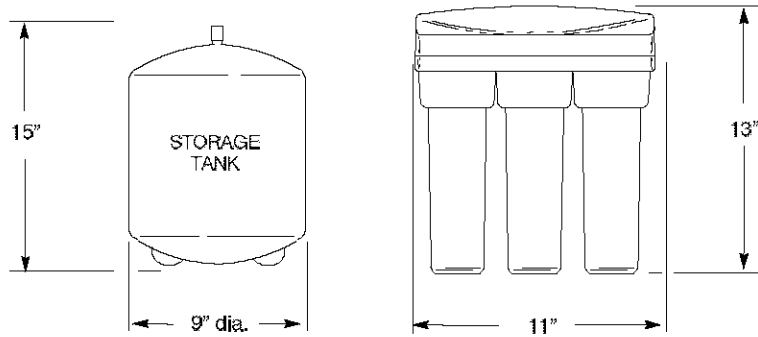

Supply water pressure limits	40 – 100 psi	Metric 280 – 690 kPa
Supply water temperature limits	40 – 100 °F	5 – 40 °C
Maximum total dissolved solids (TDS)	2000 ppm	
Maximum water hardness @ 6.9 pH	10 gpg	
Maximum iron, manganese, hydrogen sulfide	0	
Chlorine in water supply (max. ppm)	2.0	
Supply water pH limits (pH)	4 – 10	
Product (quality) water, 24 hours ①	12 gal.	45.42 liters
Waste water per gallon of product water ①	5 gal.	18.9 liters
Percent rejection of TDS, minimum (new membrane) ①	90 – 95	
Storage tank capacity (max.)	2.3 gal.	8.7 liters
Automatic shutoff control	yes	

① feed water supply at 50 psi, 77° F, and 750 TDS – Quality water production, amount of waste water and percent rejection all vary with changes in pressure, temperature and total dissolved solids.

- REMOTE LOCATION FOR REVERSE OSMOSIS SYSTEM -

REMOTE RO INSTALLATION (storage tank not shown)

Possible remote locations for the RO nearby the kitchen or bathroom sink include; (1) a basement area underneath the sink, and (2) an adjacent room or closet. Longer lengths of tubing (see parts list on page 19) and telephone cable extension (purchase locally*) may be needed.

You can run the drain tubing directly to one of several suitable open drain points, as shown below, bypassing the faucet airgap and p-trap drain. This type of drain is the preferred over the p-trap drain adapter. **Check your local codes. Always be sure to provide an air gap** between the end of the hose and the drain point.

*Telephone cable extension must consist of a male connector on one end and a female connector on the other to keep proper polarity. Polarity may be reversed if a coupler is used and monitor will not work.

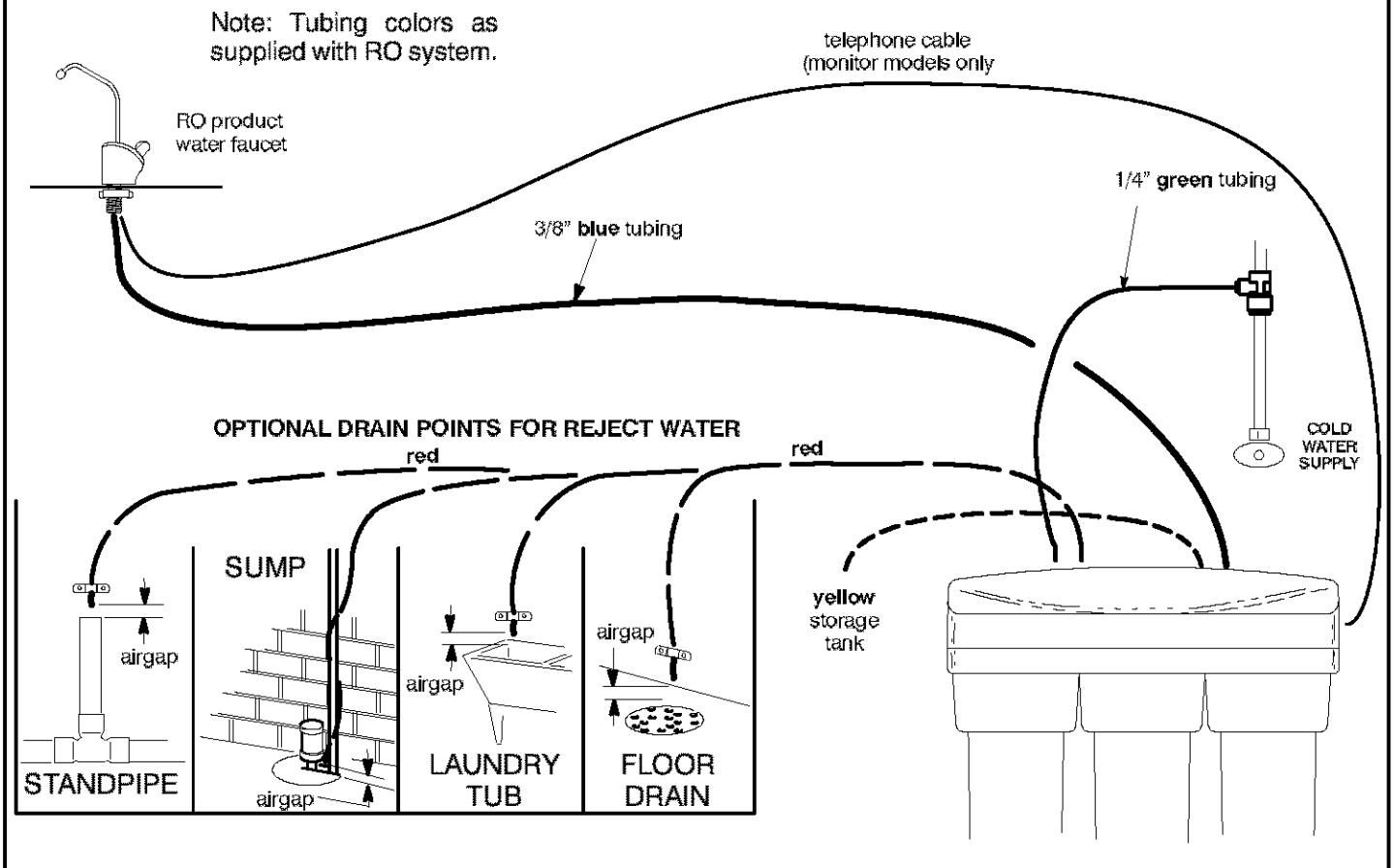

– REPAIR PARTS –

Kenmore Reverse Osmosis Drinking Water System, Model Nos. 625.384720 & 625.384750

Key No.	Part Number	Description of Part
1	7221128	Sump (3 req.)
2	7223633	O-Ring, 2-1/4" x 2-1/2" (3 req.)
3	9006062	Screw (2 req.)
4	9041700	Hanger Washer (2 req.)
5	7234210	Paddlewheel & O-Ring Kit, 625.384750 only
6	7234228	Paddlewheel Cover (includes screws), 625.384750 only
7	7234294	Pwa (incl. screw), 625.384750 only
8	7234317	Check Ball Assembly
9	7229451	Screw (4 req.)
10	7229532	Automatic Shut-off Cover
11	7250876	Diaphragm Kit
12	7234325	Plunger & Spacer Ring Kit
■	7095030	Cone Screen
13	7199402	Flow (Control) Insert
14	42-38476	Filter, Carbon Block (2 pack)
15	7233557	RO Membrane Cartridge
16	7208544	Connector, 1/4" x 1/4"
17	7208560	Connector, 1/4" x 3/8"
18	7205326	Storage Tank
19	7251034	Connector, 1/4 NPT x 3/8 Tube

Key No.	Part Number	Description of Part
20	7208489	Drain Adapter
21	7227310	Tee, Feed Adaptor
22	7228138	Faucet, Model 625.384720
	7226487	Faucet, Model 625.384750
23	7234333	Cover
24	7209566	Push-in Fitting Kit, 1/4" ①③
	7209574	Push-in Fitting Kit, 3/8" ②③
■	7161823	Tubing, 1/4" x 20' - white □ ③
■	7161784	Tubing, 1/4" x 100' - white □ ③
■	7157280	Tubing, 3/8" x 20' - white □ ③
■	7161750	Tubing, 3/8" x 100' - white □ ③
■	7227352	Owner's Manual
Supplemental Storage Tank:		
■	42-34707	Storage Tank, 3.2 gallon

□ tubing lengths for remote installations, page 17 (not included) direct replacement for colored lengths of tubing.

①② see page 18 for use locations – *Note:* This o-ring and collet are for replacement in the manifold housing only. They do not fit the other push-in fittings, key nos. 17, 18, 20, 21 and 22.

③ not included

OWNER'S MANUAL

MODEL NO.

UltraFilter 300
625.384720

UltraFilter 500
625.384750

The model number of your reverse osmosis system is found on the rating decal. This decal is on the back of the R. O. sump.

When requesting service or ordering parts, always provide the following information:

- ◆ Product Type
- ◆ Model Number
- ◆ Part Number
- ◆ Part Description

www.KenmoreWater.com



Reverse Osmosis Drinking Water System

For the repair or replacement parts you need

Call 7 am - 7 pm, 7 days a week

1 - 800 - 366 - PART

(1 - 800 - 366 - 7278)

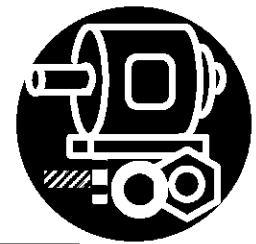

For in-home major brand repair service

Call 24 hours a day, 7 days a week

1 - 800 - 4 - REPAIR

(1 - 800 - 473 - 7247)



For the location of a

Sears Repair Service Center in your area

Call 24 hours a day, 7 days a week

1 - 800 - 488 - 1222



For information on purchasing a Sears
Maintenance Agreement, or to inquire
about an existing Agreement

Call 9 am - 5 pm, Monday - Saturday

1 - 800 - 827 - 6655



SEARS

REPAIR SERVICES

America's Repair Specialists

Free Manuals Download Website

<http://myh66.com>

<http://usermanuals.us>

<http://www.somanuals.com>

<http://www.4manuals.cc>

<http://www.manual-lib.com>

<http://www.404manual.com>

<http://www.luxmanual.com>

<http://aubethermostatmanual.com>

Golf course search by state

<http://golfingnear.com>

Email search by domain

<http://emailbydomain.com>

Auto manuals search

<http://auto.somanuals.com>

TV manuals search

<http://tv.somanuals.com>