

AUTO CHARGE 2000 PLC

AUTOMATIC DUAL OUTPUT BATTERY CHARGER



Supplied with
Dual Bar Graph Display



MODEL # : 091-237-12

INPUT: 120 Volt, 60 Hz, 3.5 Amps

OUTPUT BATTERY 1 and 2: 15 or 18 Amps
OUTPUT BATTERY SAVER: 3 Amps

File: IM_091-237-12_revC.indd
Rev: C
Revised By: SO, PG 7
Date: 05-13-2016

3 YEAR WARRANTY



scan using your mobile
device for more information

170 Cherry Avenue
West Sayville, NY 11796
www.kussmaul.com



Ph: 800-346-0857
Fax: 631-567-5826
sales@kussmaul.com

IMPORTANT SAFETY INSTRUCTIONS

I. PERSONAL PRECAUTIONS:

1. Someone should be within range of your voice or close enough to come to your aid when you work near a lead-acid battery.
2. Have plenty of fresh water and soap nearby in case battery acid contacts skin, clothing, or eyes.
3. Wear complete eye and clothing protection. Avoid touching your eyes while working near a battery.
4. If battery acid contacts skin or clothing, wash immediately with soap and water. If battery acid enters the eye, immediately flood eye with cold running water for at least 10 minutes and get medical attention immediately.
5. **NEVER** smoke or allow a spark or flame in the vicinity of the battery or engine.
6. Be extra cautious to reduce the risk of dropping a metal tool onto the battery. It might spark or short-circuit the battery or other electrical part and cause a fire or an explosion.
7. Remove personal metal items such as rings, bracelets, necklaces, and watches when working with a lead-acid battery. A lead-acid battery, when shorted, can produce a current sufficient to weld a ring or the like metal causing a severe burn.
8. Use the battery charger for charging gel-cell, AGM and flooded lead-acid batteries only. Do not use the charger for charging dry-cell batteries that are commonly used with home applications. These batteries may burst and cause injury to persons and damage to property.
9. **WARNING – RISK OF EXPLOSIVE GASES:** Working in the vicinity of a lead-acid battery is dangerous. Batteries generate explosive gases during normal battery operation.

II. CHARGER PRECAUTIONS:

1. **NEVER** charge a frozen battery.
2. Make sure the cord is located so that it will not be stepped on, tripped over, or otherwise subjected to damage or stress.
3. Do not operate the charger with a damaged cord or plug; replace them immediately.
4. Do not operate the charger if it has received a sharp blow, been dropped, or otherwise damaged.
5. Do not disassemble the charger. Incorrect reassembly may result in a risk of electric shock and fire.
6. To reduce the risk of electric shock, disconnect the charger from the AC source before attempting any maintenance or cleaning.
7. **LOCATION OF CHARGER:** The charger should be mounted on a wall, vehicle floor, ventilated compartment or other suitable surface as close to the batteries to be charged as possible. Do not block the charger's fan or air intakes. Do not mount the charger directly over the batteries as fumes may cause excessive corrosion. The area should be well ventilated and free from excessive moisture, exhaust manifolds, and battery fumes. For maximum performance, the charger should not be located in an area of extreme high temperature. The charger is not waterproof. Do not mount the charger where there is a possibility of water entering the unit. Evidence of water entry into the charger will void the warranty.
8. **CAUTION:** Do not attempt to increase battery bank capacity by splitting the output of one of the banks with a diode-type battery isolator. The diode isolator lowers the charger voltage and results in under-charging the batteries connected to it. If additional capacity is required it is preferable to add another isolated or parallel battery.

III. GROUND AND AC POWER CORD CONNECTION:

1. The charger should be grounded via the AC power connection to reduce the risk of electrical shock.
2. The charger must be plugged into or wired to an outlet that is an over-current protected 3 prong outlet. Alternatively, it may be routed through a separate dedicated fuse or circuit breaker on an AC distribution panel with proper earth/safety ground. All wiring shall comply with UL recommendations, NEC or NFPA standards and local ordinances. Never alter the AC cord or plug if provided. Any modification of the cord must only be done by a qualified electrician. Improper cord/outlet connection may result in a risk of electrical shock.
3. Observe color coding of the AC wiring as follows:

| | |
|------------|--------------------------|
| Black..... | AC Hot or LINE (fused) |
| White..... | AC Neutral |
| Green..... | AC Ground (safety/earth) |
4. **CAUTION:** (230 VAC applications only): If AC input is provided from a source consisting of two HOT or LINE leads (phase-to-phase 230 VAC input voltage); an external fuse or circuit breaker must be used to protect both hot leads.

INTRODUCTION

The Auto Charge 2000 with Parasitic Load Compensation (PLC) is a compact, microprocessor controlled, completely automatic, dual channel battery charger designed for vehicles with two batteries. The PLC charger is designed to withstand the shock and vibration encountered by vehicle mounted equipment.

FEATURES

I. AUTO CHARGE 2000 PLC DUAL CHANNEL BATTERY CHARGER

- Parasitic Load Compensation allows for user input of total accessory load amps on the vehicle. This allows the charger to shift the absorption stage set point so the battery voltage drops to the float voltage when desired current is reached
- Electronic remote sensing of true battery voltage, eliminates the need for sensing wires
- Automatic current limiting and proportioning
- Built-in Battery Saver output
- Accommodates Lead-Acid, Gelled Electrolyte, AGM and Odyssey® battery types
- Configurable for 3-Step or Float Charging
- 3 hour Safety Timer while in 3-Step mode
- Whisper quiet cooling fan
- Patent pending

II. CHARGE CONTROLS & ELECTRONIC REMOTE SENSING

The Auto Charge 2000 PLC contains two independent, precision charge controller circuits. This enables the batteries to be charged individually and provides battery isolation. Remote sensing circuits measure each battery's true voltage and eliminate the need for additional sense wires. The output current of the charger is a series of pulses whose frequency is determined by the power line frequency. The Auto Charge 2000 PLC measures the battery voltages during brief intervals between pulses while no charge current is flowing. The battery voltages are compared to a standard and any error is detected and used to control the charger output at the desired level. There is no "trickle charge", therefore, no danger of overcharging and water boil-off.

III. AUTOMATIC CURRENT LIMITING

Some battery chargers can be overloaded due to the high charging current required when batteries are severely discharged. The Auto Charge 2000 PLC contains dual current limiting circuits. These circuits automatically limit the total output current (for the two batteries combined) to the rated 15 amperes (18 A with battery saver turned off). They function when charging a deeply discharged battery or if the starter cranks while charging, making an ignition interlock circuit unnecessary. The charger automatically proportions the charging current to each battery. When charging unequally charged batteries, the lower charged battery receives a higher charging current, up to the total 15 amperes. When the batteries are equal, the current is shared equally until they are fully charged.

IV. PLC - PARASITIC LOAD COMPENSATION

This new feature is designed specifically to meet the requirements of emergency vehicles. Most emergency vehicles have many parasitic loads on their systems (flash lights, gas detectors, computers, monitoring systems

and other items). These loads can cause a standard 3-step charger to over-charge the batteries. Parasitic Load Compensation allows you to input the total number of parasitic load amps on the vehicle. The charger will then shift the absorption stage set-point so the battery voltage will drop to the float voltage when the desired current is reached. In short, the parasitic loads are invisible to the charger. This will lead to longer battery life and prevents battery overcharging and overheating. This feature compensates for parasitic loads connected to battery 1 only.

WIRING AND SWITCH SETTINGS

I. BATTERY CHARGER WIRING INSTRUCTIONS

1. Refer to Installation Wiring Diagram.
2. Refer to Wiring Specifications to determine the recommended wire size and maximum lengths. Using a smaller gauge may cause overheating of the terminal. Additional information is available upon request if longer, larger wiring is required.
3. Torque DC output connector. Refer to Specifications.
4. Set the front panel switches for the appropriate battery type, charge method, safety timer value, battery saver mode and parasitic load requirement. Refer to Sections III, IV, V and VI.
5. Double check all wiring and switch settings before applying AC power to charger.
6. Apply AC power (shoreline power) to the line cord and observe that the charger is operating.
7. Verify that the battery voltage appears at the charger output terminals.

II. WIRING SPECIFICATIONS

| Length of Wire to Battery (feet) | 0-5 | | | | 5 - 10 | | | | 10 - 20* | | | |
|---|-------|------------|------------|--------|--------|------------|------------|--------|----------|------------|------------|--------|
| Battery Charger Connections | COM - | V. BAT 1 + | V. BAT 2 + | B.S. + | COM - | V. BAT 1 + | V. BAT 2 + | B.S. + | COM - | V. BAT 1 + | V. BAT 2 + | B.S. + |
| Wire # Gauge (awg) | 14 | 14 | 14 | 16 | 12 | 12 | 12 | 16 | 10 | 10 | 10 | 16 |
| * Consult factory if length of wire to battery is longer than 20 feet | | | | | | | | | | | | |

III. BATTERY TYPE SELECTION SWITCHES

Switches 1 and 2 should be set to match the battery chemistry.

Lead-Acid - Both switches down (off) - factory default setting

Gelled Electrolyte (Gel Cell) - Switch 1 down (off) and Switch 2 up (on)

AGM - Switch 1 up (on) and Switch 2 down (off)

Odyssey® - Both switches up (on)

IV. FLOAT / 3-STEP CHARGE MODE SELECTION SWITCH

Switch 3 should be set for the desired charging method, Float or 3-Step. When in 3-step mode, the safety timer period is 3 hours. The safety timer period begins when AC power is applied to the charger. The absorption phase of 3-step charging terminates when the safety timer expires, or

when the PLC threshold setting is reached. If no PLC settings are set, the threshold is 0.5A. The charger then switches to, and remains in, float mode while AC power is applied.

Float Charge Only – Switch 3 down (off) - factory default setting
3-Step with 3 Hour Safety Timer - Switch 3 up (on)

V. SWITCH POSITION 4 – NOT USED ON THIS MODEL

Switch 4 is not used on this model. It should be left down (off), the factory default setting

VI. BATTERY SAVER AND BATTERY SAVER SWITCH

A low ripple, current limited, 3 ampere Battery Saver is built into the charger. When connected as shown in the installation wiring diagram, loads on the battery such as radios and rechargeable hand lights are automatically switched to the Battery Saver when power is applied to the charger. The Battery Saver allows more efficient charging by removing these loads. Switch 5 enables the Battery Saver when set in the up (on) position. If it is not required, turning the Battery Saver off by setting switch 5 down (off) will enable an additional 3 amperes of charging current (18 A). This is the factory default setting. A Battery Saver filter is not required.

WHEN A BATTERY SAVER OVERLOAD OCCURS:

- a. Remove the loads for approximately two minutes
- b. Reduce the load to 3 amperes or less
- c. Reapply the load to the Battery Saver

No fuses are required or provided as the Battery Saver contains a self resetting automatic circuit breaker.

VII. PARASITIC LOAD COMPENSATION SWITCHES (3-Step mode only)

Switches 6, 7 and 8 should be set to match the parasitic load on battery 1 (excluding any Battery Saver load). These switches control the point at which the charger will terminate the absorption phase of the 3-step charging cycle. The possible settings are 0, 1, 2, 4, 6, 8, 10 or 12 amperes. If there are no parasitic loads on battery 1, or if they are all are on the Battery Saver, then set these three switches to the down (off) position. This is the factory default setting.

VIII. REMOTE BATTERY CHARGE CONDITION INDICATOR (Standard equipment)

This remote indicator shows the charge condition of each battery in 10 levels from “LOW CHARGE” to “FULLY CHARGED”. This device indicates a defective battery when the bar graph does not rise to the “FULLY CHARGED” level after an extended period of charging.

NOTE: If a battery is being charged with an external load of 1.5 to 4 amperes across its terminals, the bar graph may move down 1 or 2 levels. This does not indicate a defective battery. To avoid this,

connect all external loads to the Battery Saver terminals. Loads connected to the Battery Saver will be powered by the Battery Saver power supply when the AC power is "ON", or they will be connected to battery 1 when the AC power is "OFF".

DIP SWITCH SETTINGS

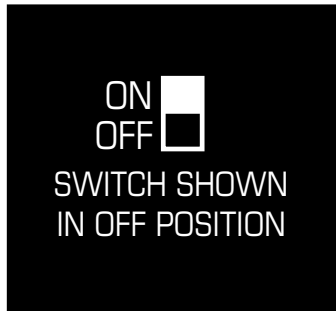

Legend on front panel of charger

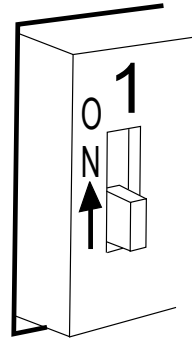

This is what the dip switch should look like when setting it to the legend on the front panel of the charger.

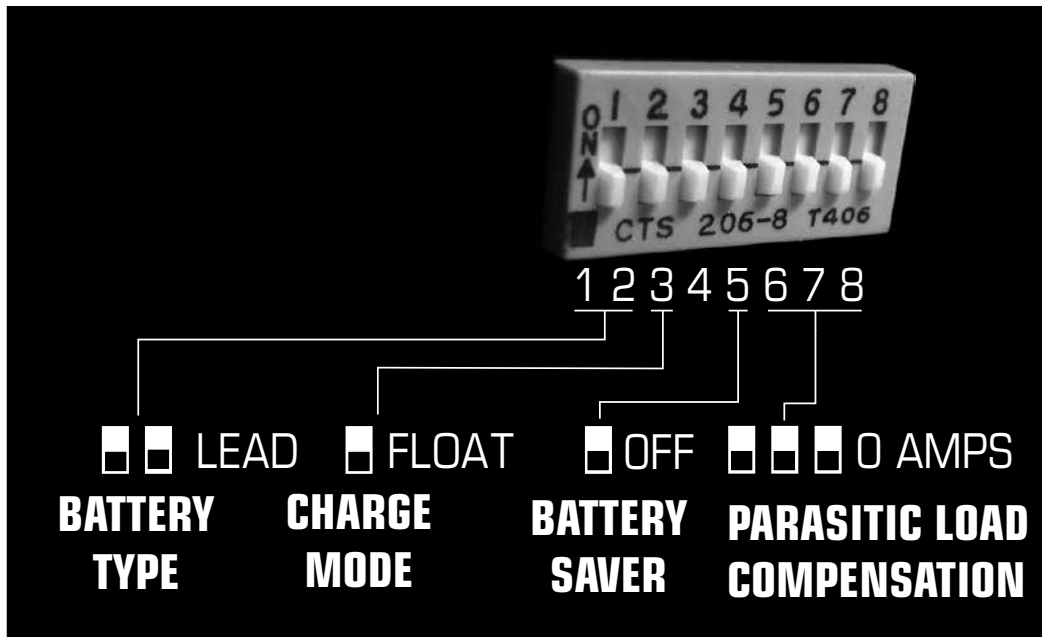

NOTE: The charger is shipped with ALL dip switches in the down position. This configuration is for float charging of a Lead Acid battery with battery saver and parasitic load compensation turned off.

INSTALLATION WIRING DIAGRAM

I. FOR STANDARD DUAL BAR GRAPH DISPLAY, 091-039-001

Wiring Diagram shown is for a 10 foot installation

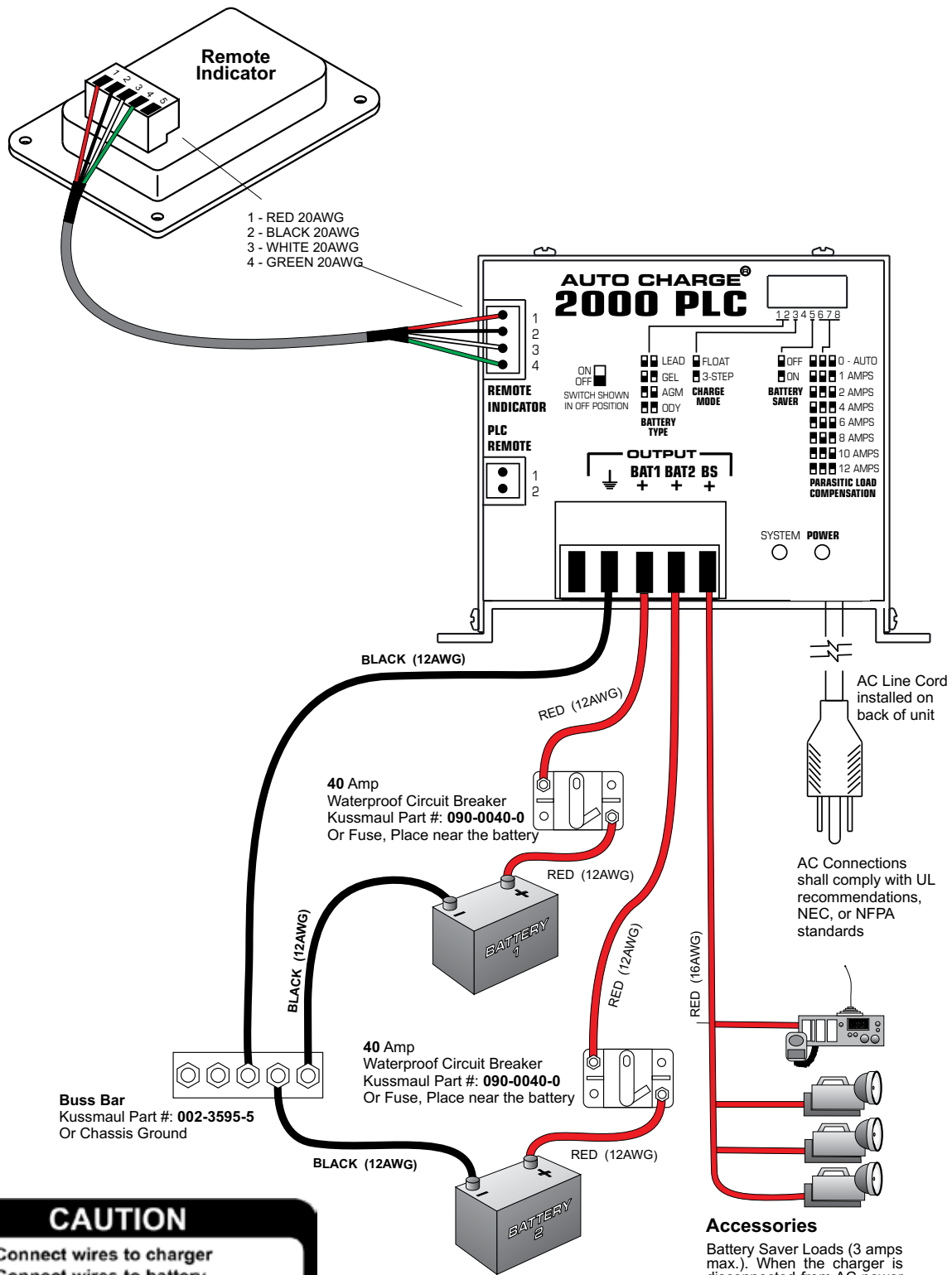

CAUTION

1. Connect wires to charger
 2. Connect wires to battery
 3. Apply AC power
- Caution installing battery wires into front connector. A screwdriver could short to the chassis cover.

SPECIFICATIONS

Input Power: 120 Volt, 60 Hz, 3.5 amperes

Input Fuse: 6 ampere, fast blow

Output Power - Bat : 15 amperes max (18 amperes if Battery Saver is turned off)

| Battery Type | Float V DC | Absorbtion V DC |
|--------------------|------------|-----------------|
| Lead-Acid | 13.25 | 14.00 |
| Gelled Electrolyte | 13.50 | 14.25 |
| AGM | 13.50 | 14.40 |
| Odyssey® | 13.60 | 14.70 |

Output Power - Battery Saver: 13 Volts DC, 3 amperes max

Remote Sensing: Electronic, sense wires not required

LED Status Indicators:

Power: Green LED, Indicates 120 Volt AC power applied

System: Yellow LED:

Fast Flash (5 times per Second) indicates battery reverse polarity

Slow Flash (once per second) indicates no battery is connected

Solid On indicates charger is in current limit (normal operation)

Solid Off indicates normal operation

Brief Flash (once every 2 seconds) indicates 3-step boost mode operation

Cooling Fan: The whisper quiet cooling fan exhausts air from the rear of the charger. When the Battery Saver is enabled, it is continuously on while AC power is applied to the charger. It turns on at 4 amperes of output current and turns off at 3 amperes when the Battery Saver is disabled.

Max Operating Temp: 104°F (40°C) when the battery saver is ON

122°F (50°C) when the battery saver is OFF

Torque: DC Output Connector: 15 in. lbs.

Remote Display Options: Dual Bar Graph Display

Output Waterproof Circuit Breaker (Optional): Bat 1 and 2 - 40 amperes, P/N: 090-0040-0

Output Buss Bar (Optional): 5 Studs, P/N: 002-3595-5

Weight: 11 pounds

OUTLINE DRAWING

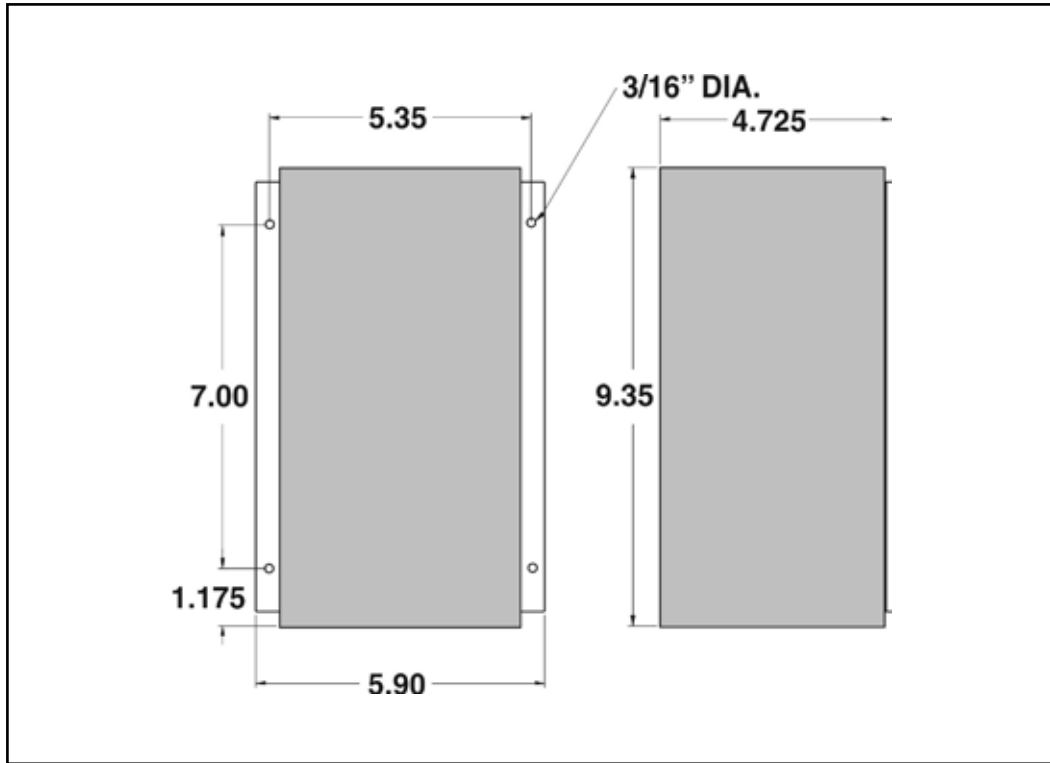

OPTIONAL ACCESSORIES

I. STANDARD DUAL BAR GRAPH DISPLAY, MODEL #: 091-39-IND

- Dual 10-Segment LED display indicate the “state of charge” and the general condition of the batteries



II. RECOMENDED 40 AMP WATERPROOF CIRCUIT BREAKER, MODEL #: 090-0040-0

- Combines switching and circuit breaker function
- Compact size and surface mount configuration
- Protects high amperage circuits
- Latch arms resets breaker after overload
- Cannot be held in ON position if short remains on circuit
- Waterproof - Ideal for truck applications



INSTALLATION RECORD

DATE INSTALLED _____

INSTALLED BY _____

VEHICLE IDENTIFICATION _____

VEHICLE OWNER _____

WARRANTY POLICY

All products of Kussmaul Electronics Company Inc. are warranted to be free of defects of material or workmanship. Liability is limited to repairing or replacing at our factory, without charge, any material or defects which become apparent in normal use within 3 years from the date the equipment was shipped. Equipment is to be returned, shipping charges prepaid and will be returned, after repair, shipping charges paid.

Kussmaul Electronics Company, Inc. shall have no liability for damages of any kind to associated equipment arising from the installation and/or use of the Kussmaul Electronics Company, Inc. products. The purchaser, by the acceptance of the equipment, assumes all liability for any damages which may result from its installation, use or misuse, by the purchaser, his or its employees or others.



Members of
Fire and Emergency
Manufacturers and
Service Association



Members of
National Fire
Protection
Association



Members of
Fire Apparatus
Manufacturers
Association



170 Cherry Avenue
West Sayville, NY 11796
www.kussmaul.com



Ph: 800-346-0857
Fax: 631-567-5826
sales@kussmaul.com

Free Manuals Download Website

<http://myh66.com>

<http://usermanuals.us>

<http://www.somanuals.com>

<http://www.4manuals.cc>

<http://www.manual-lib.com>

<http://www.404manual.com>

<http://www.luxmanual.com>

<http://aubethermostatmanual.com>

Golf course search by state

<http://golfingnear.com>

Email search by domain

<http://emailbydomain.com>

Auto manuals search

<http://auto.somanuals.com>

TV manuals search

<http://tv.somanuals.com>