

# **AUTO-PUMP® 12V HP-VER**

## **12VDC HIGH OUTPUT**

### **AIR COMPRESSOR SYSTEM**

**FOR VERTICAL MOUNT ONLY**



**MODEL # : 091-9-12V-HP-VER**

**INPUT : 10-15 volt, 11 amp**

**OUTPUT : 125 PSI MAXIMUM**

File: 091-9-12V-HP-VER\_revA  
Rev: A  
Revised By: PSS/JRN  
Date: 8-25-2017

1 YEAR WARRANTY

---

170 Cherry Avenue  
West Sayville, NY 11796  
[www.kussmaul.com](http://www.kussmaul.com)

 **KUSSMAUL™**  
**ELECTRONICS**  
*ENERGIZED AND READY, WHEN SECONDS COUNT*

Ph: 800-346-0857  
Fax: 631-567-5826  
[sales@kussmaul.com](mailto:sales@kussmaul.com)

# INTRODUCTION

---

The Auto-Pump Air Compressor system is a compact electric motor operated single cylinder air compressor designed specifically for installation on vehicles with air brakes. During long idle periods of the vehicle when even the slightest seepage can cause an air brake system pressure to drop below the brake lockup pressure, the Auto Pump automatically starts to maintain the pressure. The unit also has an automatic water separator that drains the water from the separator bowl whenever the pump is cycled.

The Auto Pump motor is directly coupled to the compressor section eliminating all belts and pulleys assuring long life and reliable operation. A heavy duty pressure switch is adjusted to start the compressor when the system pressure drops below 105 psi and stops the compressor when 125 psi is attained. The start up pressure is field adjustable - the pressure differential between start up and stopping is fixed. Please read and follow the installation instructions carefully. The Auto Pump requires no routine maintenance. A careful installation will assure years of trouble free operation.

# **CAUTION**

**NO CONDENSATE OR  
WATER MUST BE ALLOWED TO ENTER  
OR ACCUMULATE IN THE OUTPUT  
OF THE AUTO PUMP.  
ROUTE OUTPUT PRESSURE  
LINE DOWNWARD FROM  
AUTO PUMP TO PERMIT  
MOISTURE TO DRAIN AWAY.**

**WATER IN THE PUMP  
OUTLET WILL INDUCE**

# **FAILURE !**

**WATER DAMAGE WILL  
VOID WARRANTY**

**FOR VERTICAL MOUNT ONLY**

**THIS MODEL 091-9-12V-HP-VER IS FOR VERTICAL MOUNT ONLY.  
FOR HORIZONTAL MOUNTING USE MODEL 091-9-12V-HP-HOR.**

# VEHICLE TUBING INSTALLATION

1. Mount all components in a suitable location, preferably in a high area above the air system . Do not mount in engine compartment or near any source of heat or dirt. The system may be connected to any point in the vehicle's air system.
2. Mount the air compressor in a vertical position as shown.
3. **CAUTION** no condensate or water must be allowed to enter or accumulate in the output of the Auto Pump. Route output pressure line downward from Auto Pump to permit moisture to drain away. **Water in the pump outlet will induce failure.**
4. All connection for air lines are 1/4" NPT. Use Teflon tape, or equivalent on all connections to insure no leakage of air.
5. The recommended installation of the Auto Pump air compressor system is shown below.
6. Mount the air compressor. Connect a suitable piece of flexible tubing from the outlet port of compressor to the air tank. (Tubing and connectors are not supplied.)
7. An optional Mounting Plate 091-9-12V-HP-H, is available to reduce any vibration and noise from Auto Pump and to simplify pump mounting.

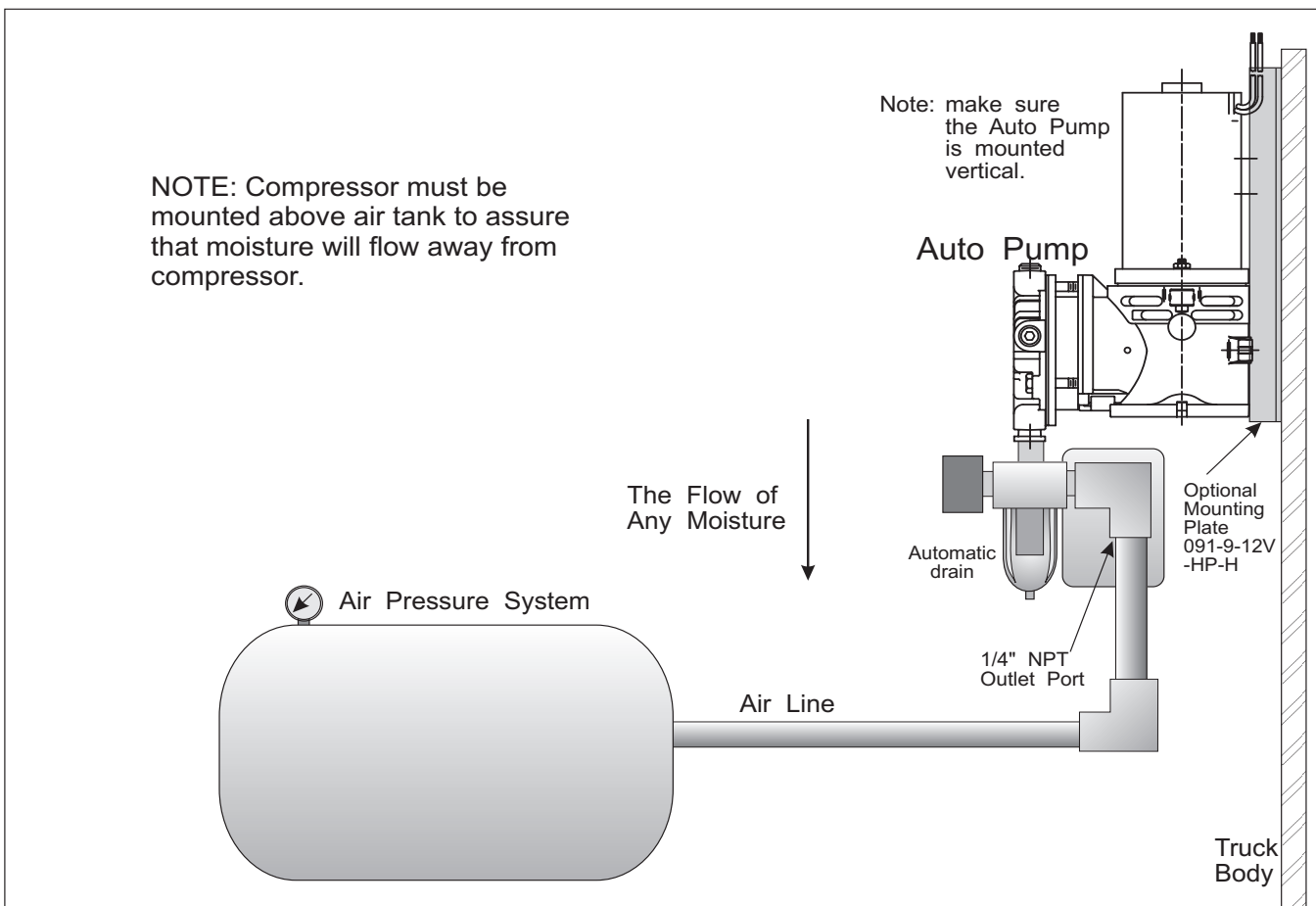

**THIS PUMP IS FOR VERTICAL MOUNT ONLY**

# VEHICLE WIRING INSTALLATION

1. Remove cover of the Pressure Switch on the Auto Pump.
2. Wire the pressure switch to the battery and a good chassis ground, use #14 AWG WIRE MINIMUM.
3. Reinstall cover of Pressure Switch.
4. The compressor is calibrated to cut-in at 105 PSI and cut-out at 125 PSI . For higher cut-in and cut-out, turn the range nut clockwise. To lower cut-in turn range nut counterclockwise. Do not exceed 135 PSI.
5. 091-9-12V-HP-VER AUTO PUMP can be wired to a positive or negative system vehicle.
6. Optional switch and fuse can be installed as shown (use 20 amp rated switch and 15 amp (SLO-BLO fuse).

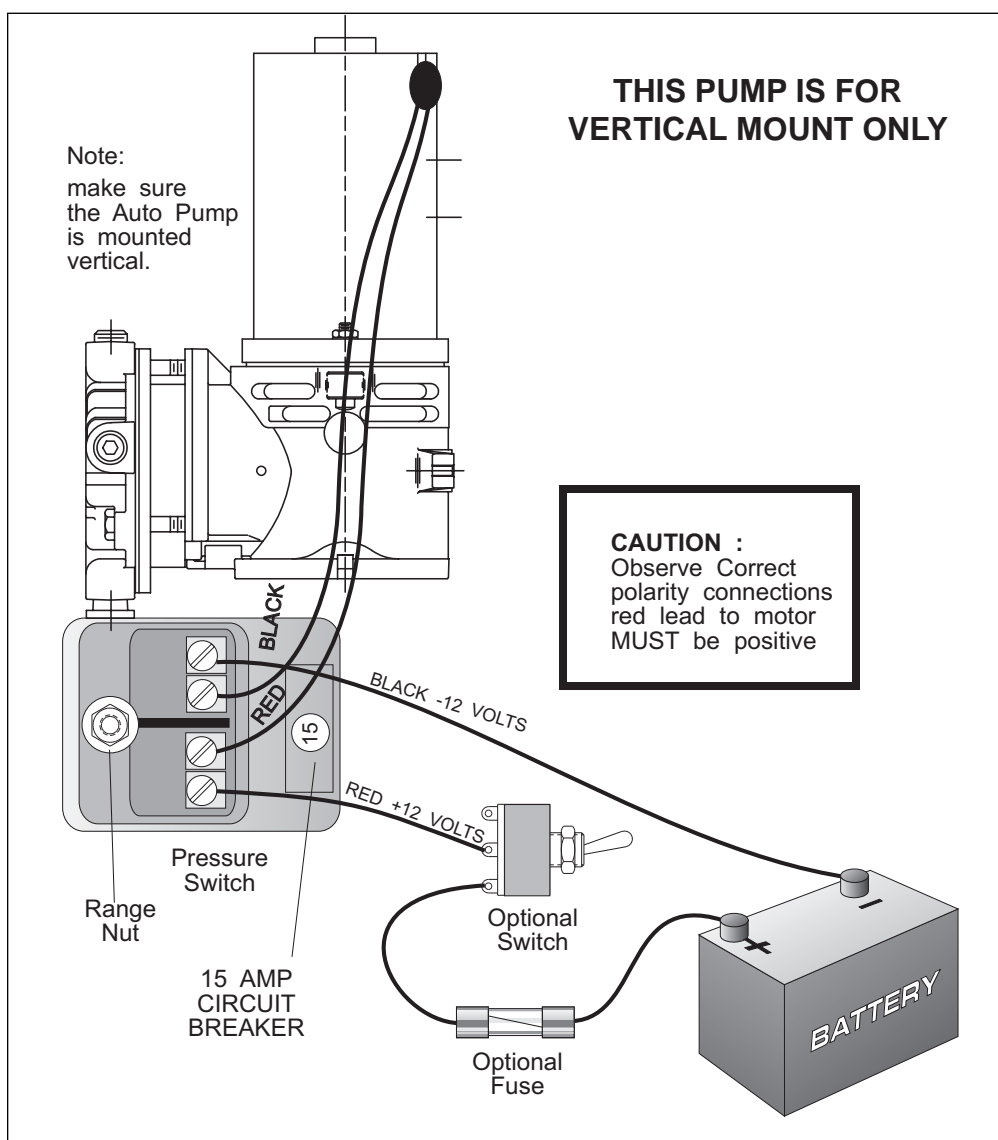

**COMPRESSOR OUTPUT IS 135 PSI MAXIMUM. DO NOT EXCEED 135 PSI OR YOU WILL VOID WARRANTY.**

# TEMPLATE AUTO PUMP

---

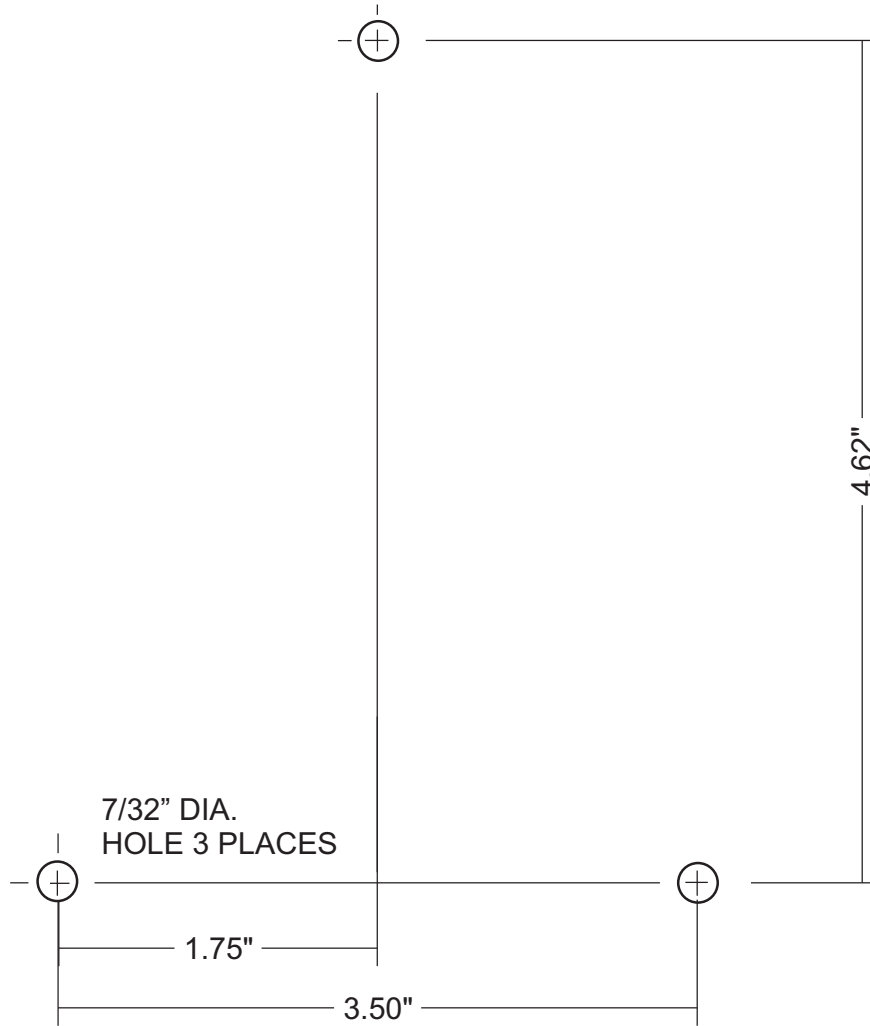

# SPECIFICATIONS

**Input Voltage:** 10 - 15 Volts DC

**Input Current:** 11 Amperes Max

**Compressor Output:** .30 SCFM @ 80 PSI, .35 SCFM @ 60 PSI, 0.80 CFM @ OPEN FLOW

**Temperature Range:** 0C to 43C (meets NFPA1901 2016 4.14.3)

**Motor Horsepower:** .10 HP

**Motor Type:** Permanent Magnet

**Pressure Switch:** Set to 105 PSI Cut-in, 125 PSI Cut-out (+/- 5 PSI)

**Switch Differential:** 18 PSI Nominal

**Outlet Connection:** 1/4 NPT, Female

**Weight:** 10 pounds

# OUTLINE DRAWING

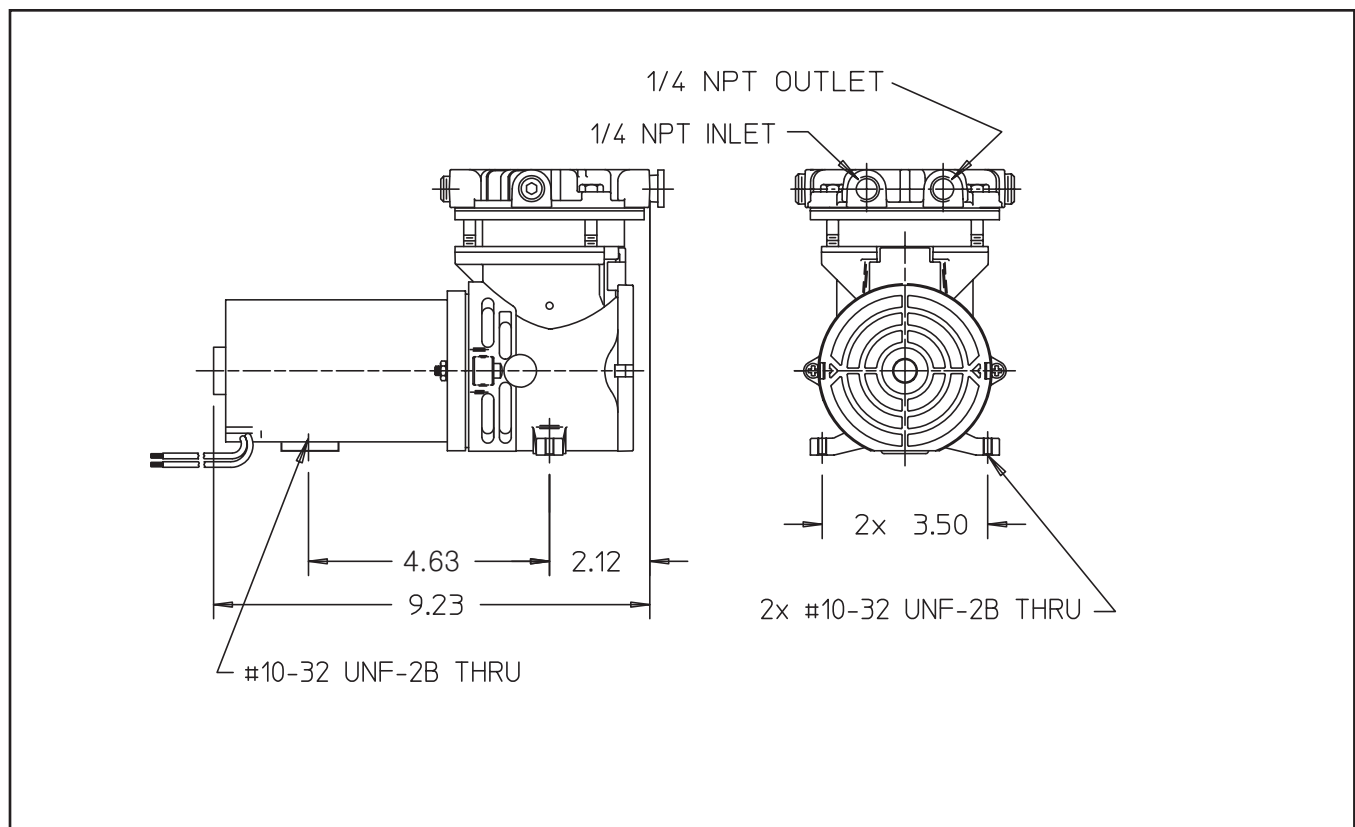

170 Cherry Avenue  
West Sayville, NY 11796  
www.kussmaul.com



Ph: 800-346-0857  
Fax: 631-567-5826  
sales@kussmaul.com

# ACCESSORIES

---

## MOUNTING PLATE

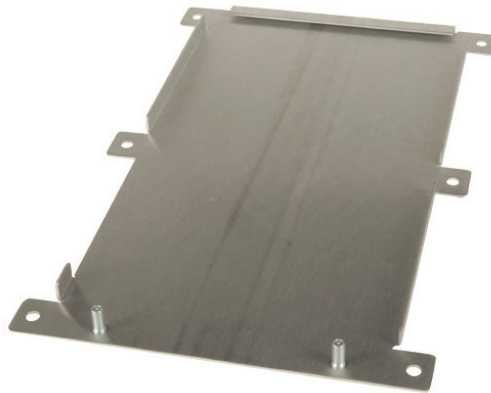

MODEL # 091-9-12V-HP-H  
FOR SIMPLIFIED MOUNTING



# INSTALLATION RECORD

---

DATE INSTALLED \_\_\_\_\_

INSTALLED BY \_\_\_\_\_

VEHICLE IDENTIFICATION \_\_\_\_\_

VEHICLE OWNER \_\_\_\_\_

# WARRANTY POLICY

---

All products of Kussmaul Electronics Company Inc. are warranted to be free of defects of material or workmanship. Liability is limited to repairing or replacing at our factory, without charge, any material or defects which become apparent in normal use within 3 years from the date the equipment was shipped. Equipment is to be returned, shipping charges prepaid and will be returned, after repair, shipping charges paid.

Kussmaul Electronics Company, Inc. shall have no liability for damages of any kind to associated equipment arising from the installation and/or use of the Kussmaul Electronics Company, Inc. products. The purchaser, by the acceptance of the equipment, assumes all liability for any damages which may result from its installation, use or misuse, by the purchaser, his or its employees or others.



Members of  
Fire and Emergency  
Manufacturers and  
Service Association



Members of  
National Fire  
Protection  
Association



Members of  
Fire Apparatus  
Manufacturers  
Association



---

170 Cherry Avenue  
West Sayville, NY 11796  
[www.kussmaul.com](http://www.kussmaul.com)



Ph: 800-346-0857  
Fax: 631-567-5826  
[sales@kussmaul.com](mailto:sales@kussmaul.com)

## Free Manuals Download Website

<http://myh66.com>

<http://usermanuals.us>

<http://www.somanuals.com>

<http://www.4manuals.cc>

<http://www.manual-lib.com>

<http://www.404manual.com>

<http://www.luxmanual.com>

<http://aubethermostatmanual.com>

Golf course search by state

<http://golfingnear.com>

Email search by domain

<http://emailbydomain.com>

Auto manuals search

<http://auto.somanuals.com>

TV manuals search

<http://tv.somanuals.com>