



KYMCO

**Super 9
50**



OWNER'S MANUAL

Dear KYMCO Motorcycle Users:

Thank you for purchasing this KYMCO scooter and welcome to the family of KYMCO scooter riders. To enjoy safer and more pleasant riding, become thoroughly familiar with this owner manual before you ride the scooter. Your safety depends not only on your own alertness and familiarity with the scooter but also the scooter mechanical condition. A pre-ride inspection before every outing and regular maintenance are essential. The quality of each KYMCO motorcycle is guaranteed.

Note: 1. The information and specifications stated in this manual are for reference only and subject to change without notice.

2. When starting the engine, the battery must be installed to facilitate starting and increase the engine performance.

TABLE OF CONTENTS

1.PRECAUTIONS FOR A SAFE RIDING	1
2.ASSEMBLY PARTS	3
3.OPERATION INSTRUCTIONS	6
IGNITION SWITCH/S TEERING HANDLEBAR LOCK	6
ELECTRIC STARTER BUTTON. HEADLIGHT SWITCH	7
HEADLIGHT DIMMER SWITCH/PASSING SIGNAL SWITCH	
HORN BUTTON/TURN SIGNAL SWITCH	8
SEAT LOCK/MET-IN BOX. HELMET BUCKLE	9
INSTRUMENTS	10
4.PRE-RIDE INSPECTION	11
ADVANCE INSPECTION. MOTOR OIL LEVEL INSPECTION/REFILING	11
BRAKE INSPECTION. TIRE INSPECTION	12
FUEL LEVEL INSPECTION/REFILLING	14
STEERING HANDLEBAR. REAR CUSHION	15
BRAKE FLUID LEVER INSPECTION. COOLING SYSTEM INSPECTION	16
HORN/LIGHTS INSPECTION	17
5.ENGINE STARTING METHODS	19

TABLE OF CONTENTS

TURN THE IGNITION SWITCH "ON". LOCK THE REAR WHEEL.....	19
USE THE ELECTRIC STARTER BUTTON.....	20
START WITH THE KICK LEVER.....	21
6.NORMAL RIDING METHOD.....	22
STARTING THE ENGINE. REBOUND THE MAIN STAND.....	22
CORRECT SITTING POSITION. ROTATE THE THROTTLE GRIP.....	23
7.PRECAUTIONS FOR RIDING.....	24
CORRECT RIDING. SPEED CONTROL.....	24
PROPER RIDING WILL PROLONG THE SERVICE LIFE OF ENGINE	
APPLY BOTH FRONT AND REAR BRAKES WHEN BRAKING.....	25
DO NOT MAKE SUDDEN STOP OR SHARP TURN	
BE MORE CAREFUL WHILE RIDING IN RAINY DAYS.....	26
8.HOW TO STOP RIDING.....	27
WHILE GO NEAR THE PARKING PLACE	
WHILE THE MOTOR CYCLE IS COMPLETELY STOPPED.....	27
PARKING. HANDLEBAR.....	28
9.EASY MAINTENANCE.....	29

TABLE OF CONTENTS

AIR CLEANER INSPECTION AND AIR CLEANER CLEANING&REPLACEMENT	29
FUEL SYSTEM, APPEARANCE CLEANING	30
BATTERY	31
FUSE CHANGE	32
TRANSMISSION GEAR OIL	33
SPARK PLUG INSPECTION	34
BRAKE FLUID LEVEL INSPECTION/REFILLING	
RUBBER COVER INSPECTION FOR WIRE AND CABLE	35
COOLANT REFILLING	36
COOLANT REPLACEMENT	37
10.IMPORTANT NOTICES	38
WHEN THE ENGINE FAILS TO START OR STOPS DURING RIDING	
IN CASE OF BREAKDOWN	38
POLLUTION-FREE PERIODIC MAINTENANCE SCHEDULE	39
SPECIFICATIONS	40



1. PRECAUTIONS FOR A SAFE RIDING

(1) CLOTHES

- To relax and wear comfortable clothes are the main points for a safe riding.
- To observe traffic laws, keep a cool mind, relax and be careful will provide you a safe riding.
- ① Wear helmet and fasten it tightly.
- ② Have the clothes well-arranged. Fasten shirt cuffs and keep them from hooking the brake lever.
- ③ Wear low-heeled shoes for a safe riding.
- ④ When riding, use both hands to grasp the handlebar. It is very dangerous to hold the handlebar with one hand.

▲ CAUTION:

- A motorcycle rider should not wear loose or too long clothes to avoid danger.
- During riding or 10 minutes after the motorcycle is stopped, do not touch the exhaust muffler to avoid scalding.
- When parking the motorcycle, keep it away from dry lawn or inflammables to avoid danger.

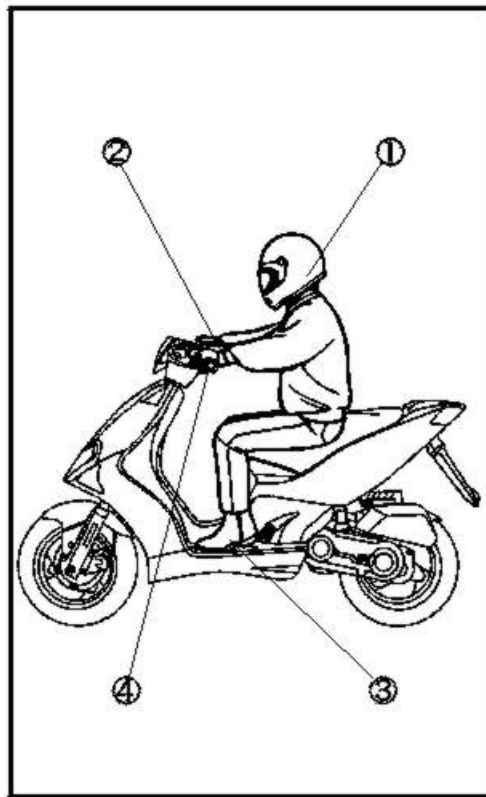

(2) RIDING METHOD

- The safety of two-wheel vehicles is influenced by sitting position. The rider should sit on the central part of the seat cushion. If the rider sits on the rear part of the seat, the load of front wheel will decrease. As a result, the handlebar will swing and cause danger to the rider.
- When making a turn, it will be easier for the rider to steer the motorcycle by leaning the body inward slightly. The motorcycle will lose its balance if the rider fails to keep his body leaning inward.
- When riding on a damaged or macadam road. Slow down the speed and hold the handlebar tightly.



(3) CARRYING GOODS

- Keep a good sitting posture to operate the motorcycle properly.
 - The feel of the handlebar will be different when carrying goods on the motorcycle. Overloading may cause the handlebar to swing. Avoid riding with overload.
- Ⓛ Max. loading capacity of the met-in box is 10kg.

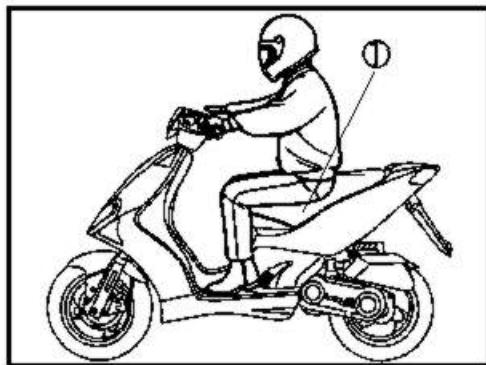

2. ASSEMBLY PARTS

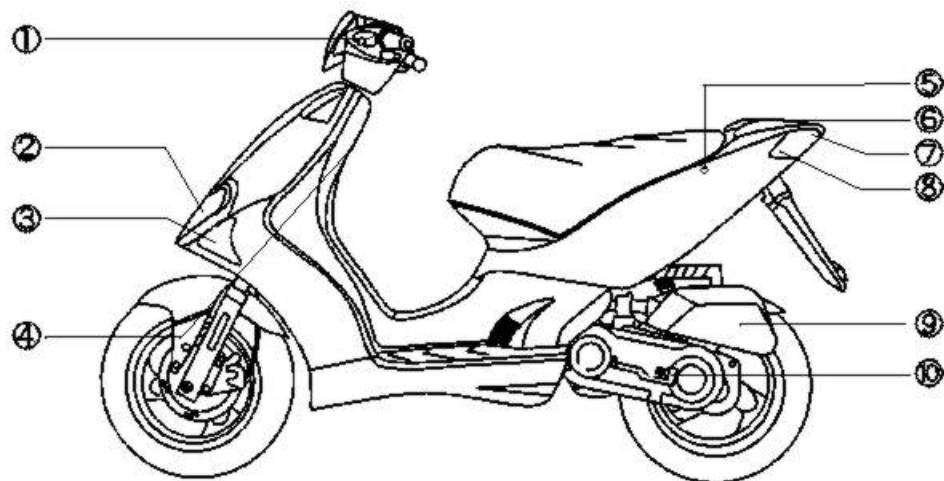

- ① Passing Signal Switch
Turn Signal Switch
Headlight Dimmer Switch
- ② Front Tool Box
- ③ L. Front Turn Signal Light

- ④ Frame Serial No.
- ⑤ Seat Lock
- ⑥ Rear Carrier
- ⑦ Taillight/Stoplight

- ⑧ L. Rear Turn Signal Light
- ⑨ Air Cleaner
- ⑩ Kick Lever

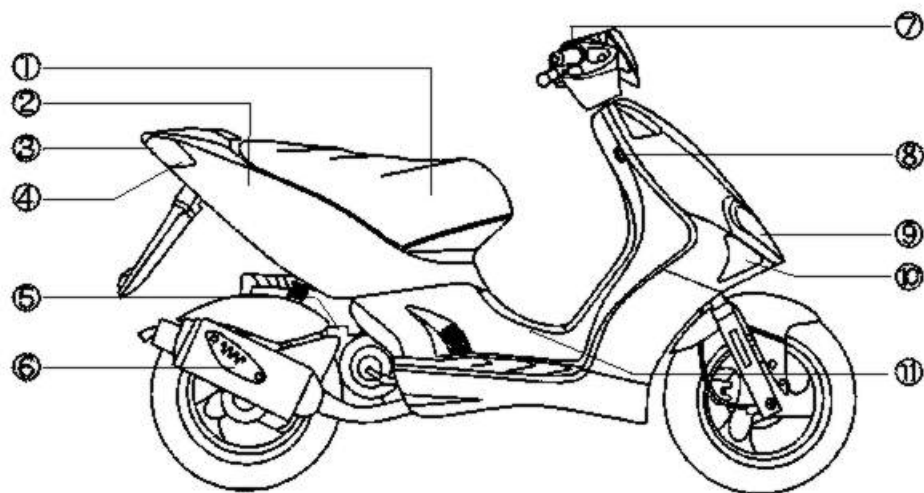

- ① Met-in Box
- ② Fuel Filler
- ③ Taillight/Stoplight
- ④ R. Rear Turn Signal Light

- ⑤ Engine Serial No.
- ⑥ Exhaust Muffler
- ⑦ Headlight Switch
- ⑧ Ignition Switch
- ⑨ Headlight

- ⑩ R. Front Turn Signal Light
- ⑪ Battery



Location of Frame Serial Number

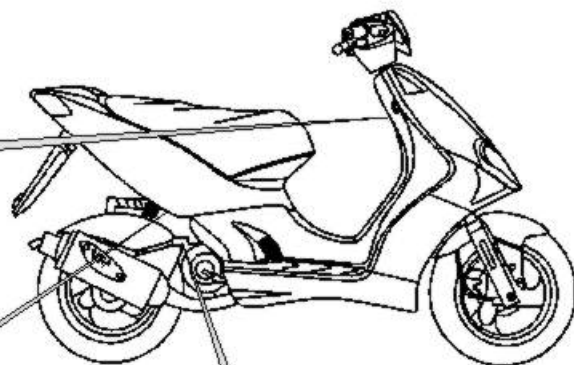

Vehicle Identification Serial Number



Location of Engine Serial Number

3. OPERATION INSTRUCTIONS

(1) IGNITION SWITCH/STEERING HANDLEBAR LOCK

- ① **ON** :At this position, power is connected to start the engine. The key cannot be taken out.
- ② **OFF** :At this position, power is cut off and the engine stops. The key can be taken out.
- ③ **LOCK** :At this position, the steering handlebar is locked.
The key can be taken out

《Locking Method》

Turn the steering handlebar left to the full and then press to turn the ignition switch key to "LOCK" position and the handlebar is locked.

《Unlocking Method》

Turn the key to "OFF" and the lock is released automatically.

▲ CAUTION:

- After locking, turn the handlebar gently to make sure that it is locked.
- Do not turn the ignition switch to "LOCK" during riding, or the handlebar will be out of control and cause accidents.
- Don't park your motorcycle at a place to hinder the traffic.

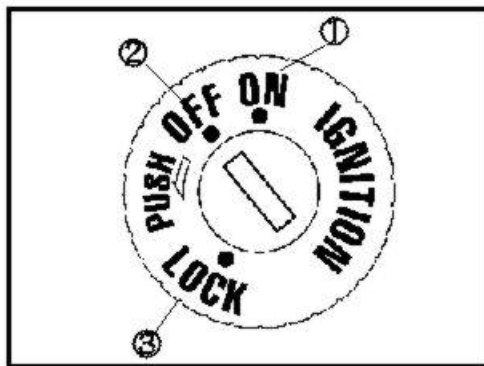

(2) ELECTRIC STARTER BUTTON

- To start the engine, first turn on the ignition switch and then press the electric starter button. At this time, be sure to fully apply the front or rear brake lever (pedal) in order to connect the power.

▲ CAUTION:

- During engine running, do not push the electric starter button to avoid engine damage.
- Turn the headlight switch and turn signal switch "OFF" before using the electric starter button.
- Release the electric starter button immediately after the engine is started.

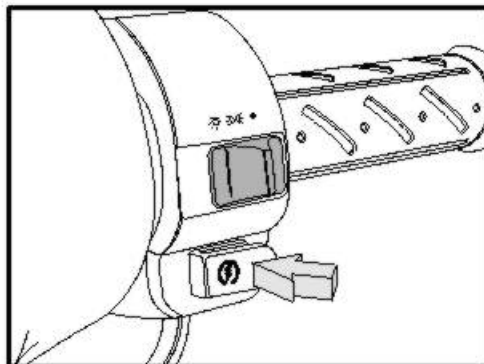

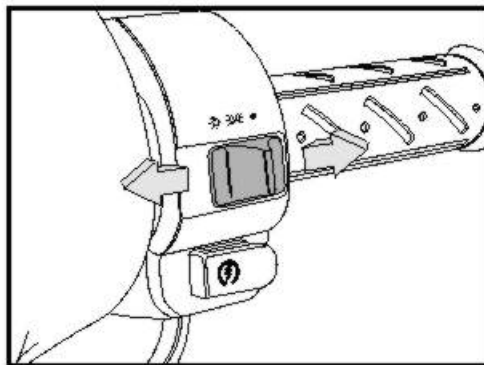

(3) HEADLIGHT SWITCH

- At this position, the position light, headlight, instrument lights and taillight turn off together.
- At this position, the position light, instrument lights and taillight light turn on.
- ⊙ At this position, the position light, headlight, instrument lights and taillight light turn on.



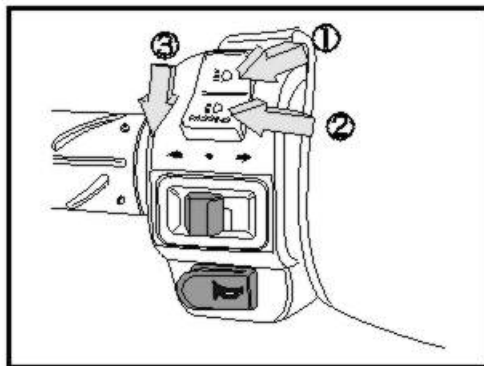

(4) HEADLIGHT DIMMER SWITCH/ PASSING SIGNAL SWITCH

- ①  Switch to this position for using high beam.
- ②  When riding in downtown area or there is a car coming from the opposite direction, use low beam to avoid affecting the visibility of coming cars.
- ③ **PASSING** When passing, continuously press and release the dimmer switch at the PASSING position and the headlight will wink to warn the coming cars.



(5) HORN BUTTON/TURN SIGNAL SWITCH

- When the ignition switch is turned "ON", press the horn button and the horn will sound. ①  For turning to the right. ②  For turning to the left. ③ Push the turn signal switch button to release it. ④ Horn Button.
- The horn and turn signal switch do not work when the ignition switch is "OFF".

▲ CAUTION:

- The turn signal light will not release automatically. Be sure to reset it after use; otherwise it may affect the traffic safety.

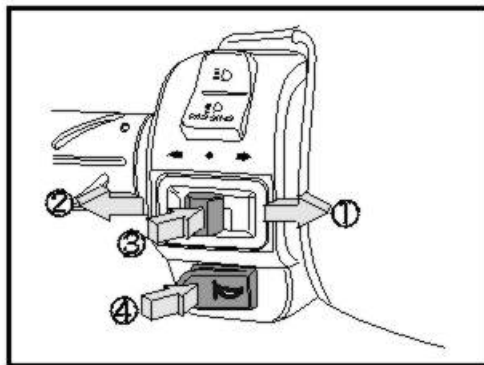

(6) SEAT LOCK/MET-IN BOX

- To open the seat, insert the ignition switch key into the seat lock and turn it right. Lift up the seat.
- Max. loading capacity of the met-in box is 10kg.
- To close the seat, put down the seat and press it down to make it lock automatically. Then slightly pull up the seat cushion to make sure that it is locked.

▲ CAUTION:

- Never put the key under the seat cushion and lock the seat.



(7) HELMET BUCKLE

1. Open the seat lock and lift up the seat.
 2. Put the helmet retaining ring into the helmet buckle.
 3. Put down the seat and it will lock automatically.
- Take out the helmet in the reserve order of the above steps.

▲ CAUTION:

- When riding, wear the helmet and do not retain it on the motorcycle to avoid damage of coated parts.



(8) INSTRUMENTS

- ① **ODOMETER:** The total riding mileage is indicated by kilometer. The figure in black and white is an unit of 100m.
- ② **SPEEDOMETER:** The riding speed is indicated by km/hour.
- ③ **MOTOR OIL INDICATOR LIGHT:** When the ignition switch is "ON", it is normal if the motor oil indicator light comes on for several seconds and then goes out. If the light does not go out, it means that the motor oil is insufficient. Please refill with the specified motor oil.
- ④ **TURN SIGNAL INDICATOR LIGHT:** When the turn signal switch is operated, this indicator light will wink.
- ⑤ **HIGH BEAM INDICATOR LIGHT:** This indicator light comes on when the long distance light is turned on.
- ⑥ **FUEL GAUGE:** The fuel gauge is to show the volume of gasoline in the fuel tank. If the fuel gauge pointer is at the red area, the fuel is insufficient. Refill 92# or 95# unleaded gasoline as early as possible.
- ⑦ **TACHOMETER:** It indicates the engine revolution per minute x 1000 RPM.
The red area in the tachometer is to remind you of the limit of the engine rpm in order to avoid shortening the engine service life.

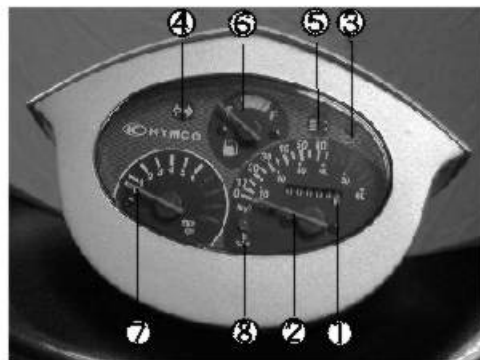

- ⑧ **TEMPERATURE GAUGE:** It indicates the temperature of engine cooling water. During riding, the temperature gauge needle should always move under the red mark. If the needle points the red mark, check the coolant level in the eye hole.

▲ CAUTION:

- Do not add any additives when refilling fuel or motor oil.

4. PRE-RIDE INSPECTION

(1) ADVANCE INSPECTION

- Get into a good habit of inspection before riding. For the sake of safety and to prevent vehicle damage and traffic accidents, the pre-ride inspection is absolutely required.

▲ CAUTION:

- Be sure to perform inspection and maintenance for your new motorcycle after it is purchased for one month or ridden for 300km.

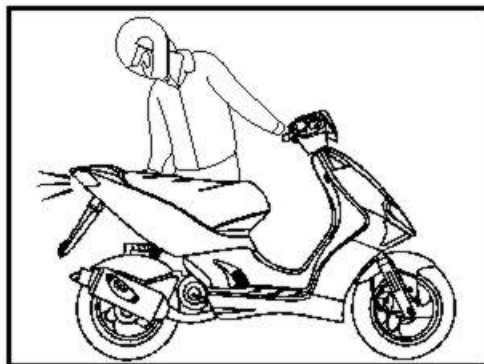

(2) MOTOR OIL LEVEL INSPECTION/REFILLING

- Place the motorcycle on its main stand.
- Open the seat and turn the motor oil tank cap counterclockwise to open it.
- Fill the oil tank with the recommended 2-stroke motor oil and close the motor oil tank cap.

▲ CAUTION:

- When adding the motor oil, the oil level shall not exceed the upper limit. Be careful not to allow foreign matters or dust to enter the oil tank.
- Use of unspecified motor oil may cause poor performance or engine damage.

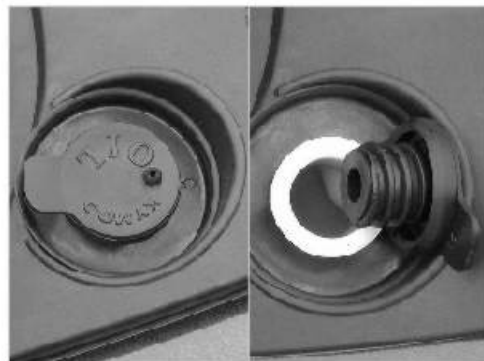

(3) BRAKE INSPECTION

- Ride the motorcycle at low speed on a dry road and respectively apply the front and rear brakes to check the brake performance.
- The brake lever should have proper free play.
- "Free play" means the distance from the position of loose brake to the position of fully applied brake.
- Measure the free play at the brake lever end and check if it is within the specified value of 1~2cm.

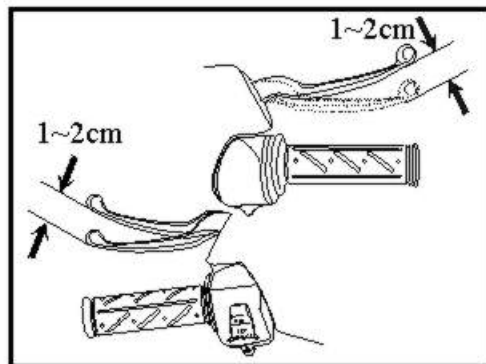

(4) TIRE INSPECTION

1. Tire Pressure Check

- Check if the tire pressure is normal when the tire is in contact with level ground.
- If there is any abnormal condition, check the tire pressure with a tire pressure gauge.
- Measure the tire pressure under room temperature.

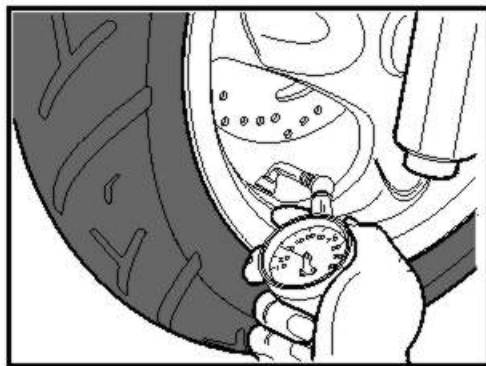

2. CRACKS & DAMAGE

- Check the tire-contact area for crack or damage.

3. ABNORMAL WEAR

- Check the tire-contact area for abnormal wear.

4. FOREIGN OBJECTS OF METAL PIECE & GRAVEL

- Check the tires and tire-contact area for imbedded objects of metal piece and gravel.

5. DEPTH OF TIRE GROOVE

- If the tire is worn to the wear limit indication mark, replace it with a new one.

NORMAL PRESSURE(1 Rider / 2 Riders)	
Front Wheel	1.75 /1.75 kg/cm
Rear Wheel	2.00/2.25 kg/cm

▲ CAUTION:

- Abnormal tire pressure, crack, damage and abnormal wear will cause unsteady handlebar and result in tire break.
- If the tire has cracks or is worn to the wear limit indication mark, replace it with a new one.

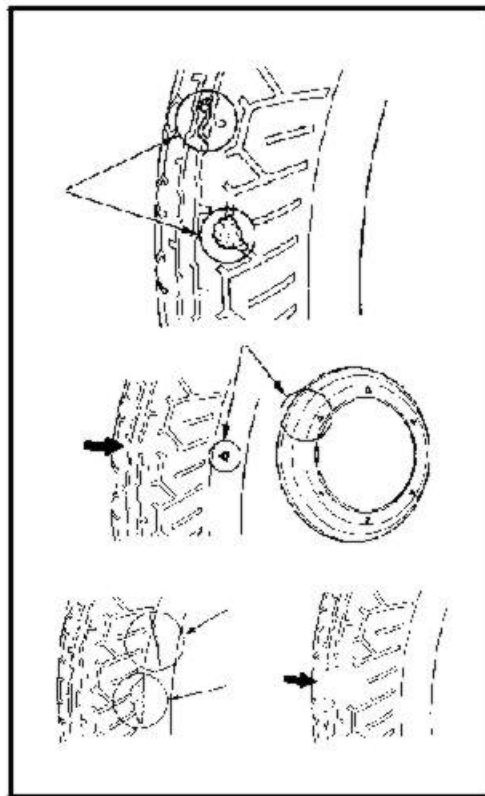

(5) FUEL LEVEL INSPECTION/REFILLING

- Check if the fuel is sufficient.
- If the fuel gauge pointer is at "E" (red line), re fill #92 or #95 unleaded gasoline as soon as possible.

《 Refilling Method 》

1. Open the seat with the ignition switch key. (Refer to P8)
2. Turn the tank cap counterclockwise with hand to open the cap.
3. Use only #92 or #95 unleaded gasoline.
4. Turn the fuel tank cap clockwise to tighten it.
5. Close the fuel tank cap in the reverse order of opening.

① Unlock

② Lock

▲ CAUTION:

- Be sure to stop the engine before refilling.
- The gasoline level shall not exceed the reference plate; otherwise the fuel will penetrate out.
- When refilling, do not add other additives to avoid engine breakdown.

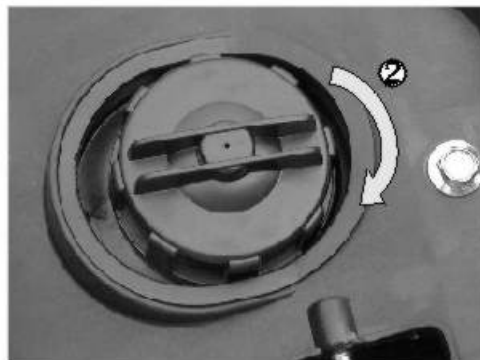
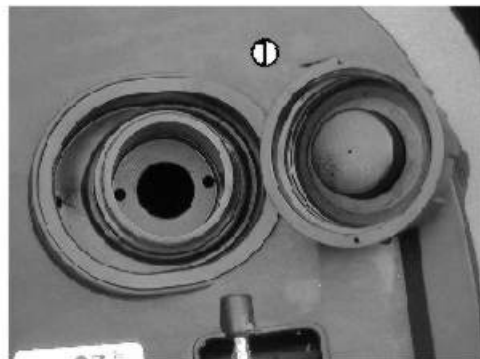

(6) STEERING HANDLEBAR

- Visually inspect the steering handlebar for damage.
- Apply the front brake and move the handlebar upward and downward to check for abnormal noise.
- Move the steering handlebar upward, downward, rightward and leftward to check for any loose parts.
- Check if the handlebar rotates freely.
- If any abnormal condition is found, go to your motorcycle dealer or for inspection.

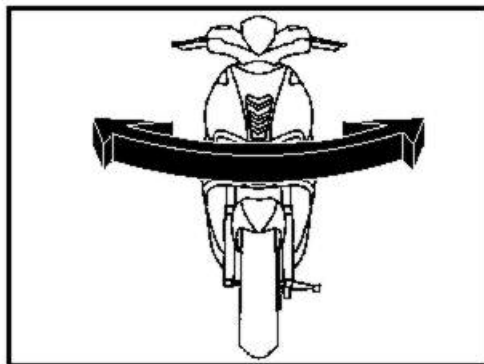

(7) REAR CUSHION

- To suit scooter behaviour to load condition rear cushion could be adjusted in spring preload.
- Using the special tool in tool kit change the preload.
- It is possible to adjust rear cushion in three positions:
① position "soft" ② position "medium"
③ position "hard"
- When you adjust rear cushion, the spring preload of rear cushions on either side must be the same.

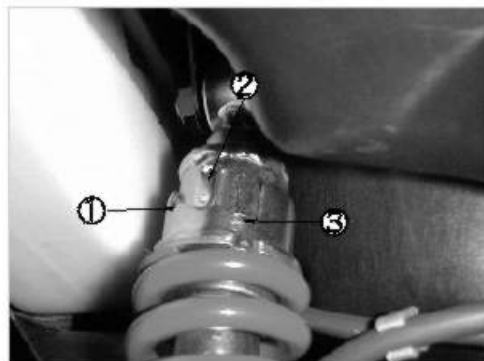

(8) BRAKE FLUID LEVEL INSPECTION

1. Keep the handlebar straight and check the front/rear brake reservoir for brake fluid level which should be kept between the upper and lower limits.
2. Check the brake shoes for wear when the fluid level is close to the lower limit.
3. If the wear of brake shoes do not exceed the specified limit, it means that there are fluid leaks. In this case, contact our distributors or service stations for inspection and repair.

① Eye Hole ② Upper Limit ③ Lower Limit

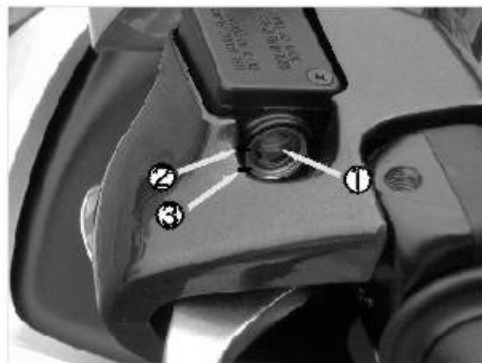

(9) COOLING SYSTEM INSPECTION

1. Place the motorcycle on its main stand on level ground.
2. Check if the coolant level of the reserve tank is between the upper and lower level lines. If necessary, remove the reserve tank cap and fill to the upper level line with distilled water.
3. If the coolant level is too low, it means that there are abnormal conditions.
 - Inspect the radiator and hoses for coolant leaks.
4. Use only distilled water to re fill the reserve tank in order to ensure good performance of the cooling system.

① Upper Level ② Lower Level

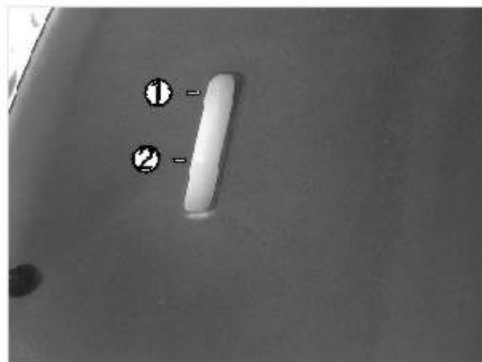

(10) HORN/LIGHTS INSPECTION

- Turn the ignition switch "ON" and press the horn button to check if it sounds.
 - Headlight/Tailight Inspection:
Start the engine and turn on the headlight switch to check if the headlight and tail light are good and check the light shells for dirt and damage.
 - Stoplight Inspection:
Apply the front and rear brake levers respectively to check if the stoplight is good. And also check the stoplight shell for dirt and damage.
 - Turn Signal Light Inspection:
Operate the turn signal switch to make sure whether the right/left front and rear turn signal lights can wink and buzz. Also check the light shells for dirt and damage.
- ① Headlight ② Taillight/ Stoplight ③ Turn signal light
④ Horn button

▲ CAUTION:

- Replace any dirty or damaged lights with new ones to avoid danger during riding.

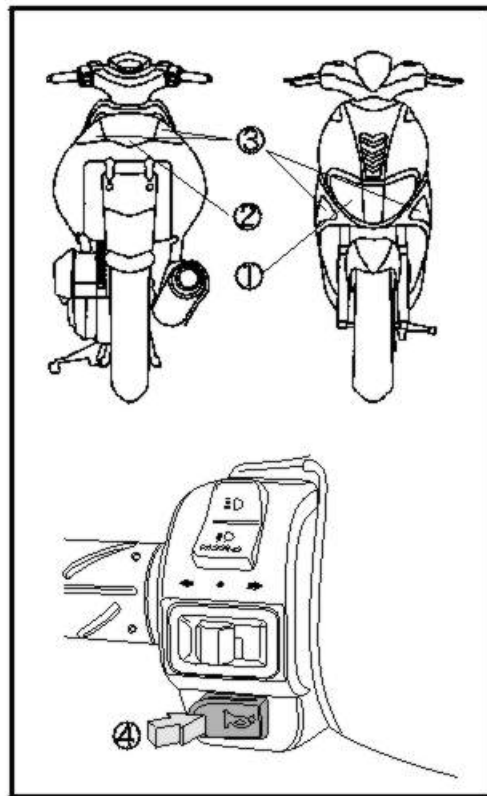

(11) FRONT/REAR SHOCK ABSORBER INSPECTION

- Check the condition of the front/rear shock absorbers by pressing down on the handlebar and seat several times.

(12) BRAKE PERFORMANCE INSPECTION

- Fully apply the front and rear brake levers and move the motorcycle forward to see if the braking effect is good.

(13) REARVIEW MIRROR ANGLE CHECK

- Sit on the motorcycle uprightly and make a viewing test of the rearview mirror angle.

(14) LICENSE PLATE CHECK

- Check the license plate for dirt and damage, then tighten it.

(15) REFLECTOR CHECK

- Check the reflector for dirt and damage.

(16) PREVIOUS ABNORMAL PARTS INSPECTION

- Make sure that the previous abnormal parts are repaired.

(17) LUBRICATION POINT CHECK

- Visually check if all motorcycle lubrication points are lubricated properly.

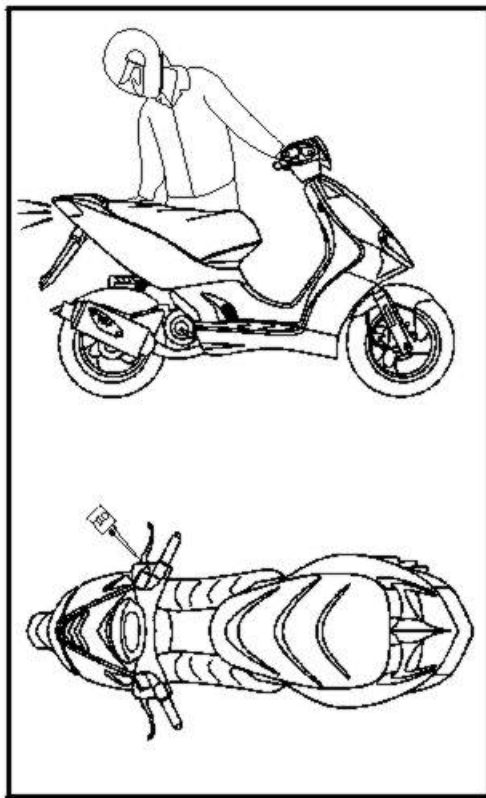

5. ENGINE STARTING METHODS

(1) TURN THE IGNITION SWITCH "ON"

- Unlock the steering handlebar.
- Turn the ignition switch "on"

▲ CAUTION:

- Check the gasoline volume and engine oil level before starting the engine.
- Be sure to erect the main stand while starting the engine.



(2) LOCK THE REAR WHEEL

- Apply the rear brake lever to connect the power for starting.

▲ CAUTION:

- In order to prevent the motorcycle from rushing out at high speed, make sure to lock the rear wheel.
- If the rear brake lever free play is incorrect, the rear wheel cannot be braked and it will cause danger easily.

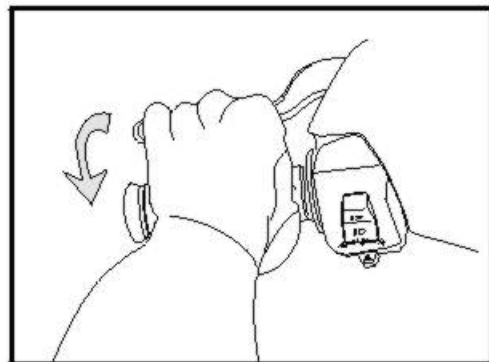

(3) USE THE ELECTRIC STARTER BUTTON

- Push the electric starter button without rotating the throttle grip.
- If the engine fails to start after the electric starter button is pressed for 3~4 seconds when it is warm, rotate the throttle grip for 1/8~1/4 turn to facilitate starting.
- When the motorcycle is not used for a long time or the fuel tank is empty, if the engine is still hard to start after the fuel tank is refilled with gasoline, slightly turn the throttle grip and press the electric starter button for several times to start the engine.
- In order to avoid battery overcharge, do not press the starter button more than 5 seconds.
- If the engine does not start after the electric starter button is pressed for 5 seconds, wait for more than 5 seconds and then press the button again or start the engine by the kick lever.

CAUTION:

- Don't press the electric starter button while the engine is running; otherwise the engine will be damaged.
- When starting the engine, the rear brake lever must be applied to connect power and the stoplight will come on when power is connected.

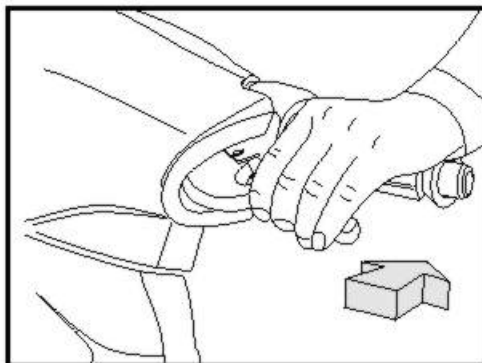

(4) START WITH THE KICK LEVER

1. Place the motorcycle on its main stand on level ground.
2. Depress the kick lever with force.
 - When the engine is cold and does not start after the kick lever is depressed for 3 ~ 4 times, rotate the throttle grip for $1/8 \sim 1/4$ turn to facilitate starting.
 - Warm up the engine for a little while (about 2 ~ 3 minutes) after cold start.
 - After the engine is started, do not accelerate suddenly and keep riding at low speed to prolong the engine service life.

▲ CAUTION:

- After the engine is started, the kick lever must be returned to its original position.
- The exhaust contains poisonous carbon monoxide which is harmful to human body. Never run the engine in a closed area.
- Turn off all light switches before starting the motorcycle.

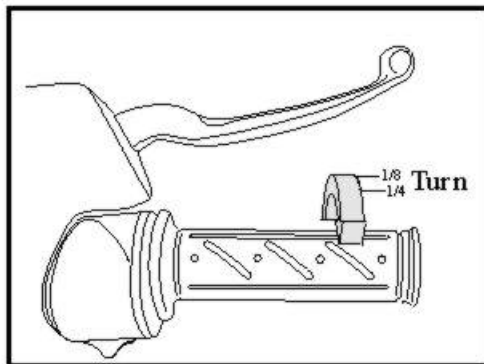

6. NORMAL RIDING METHOD

(1) STARTING THE ENGINE

- Start the engine by referring to the starting methods specified in Section 5.

▲ CAUTION:

- Keep your finger away from the button immediately after the engine is started to avoid engine damage.
- The rear brake lever should be kept at the braking position before riding.

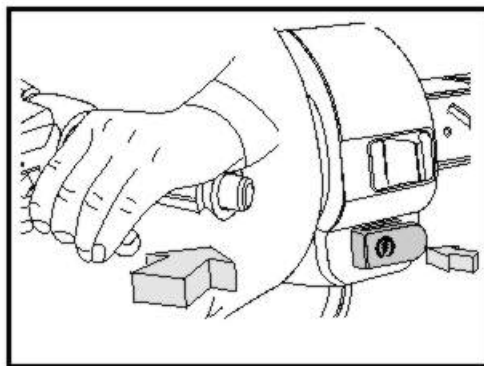

(2) REBOUND THE MAIN STAND

- Keep the rear brake lever at braking position and push the motorcycle forward, then the main stand will rebound automatically.

▲ CAUTION:

- After starting the engine and before moving, do not turn the throttle grip to increase the engine rpm.

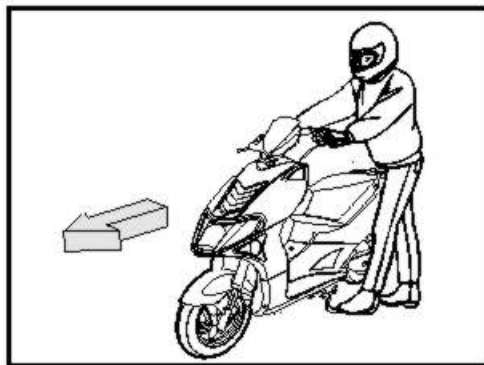

(3) CORRECT SITTING POSITION

- Ride astride on the motorcycle from the left side and sit upright. Touch the ground with left foot to avoid slipping.

▲ CAUTION:

- The rider must wear helmet, gloves and goggles.
- Do not wear any clothes which will affect riding safety.

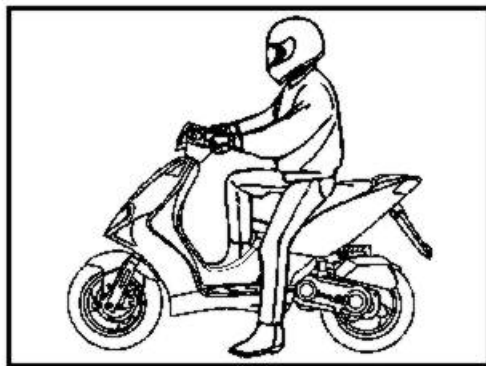

(4) ROTATE THE THROTTLE GRIP

- Release the rear brake lever and slowly rotate the throttle grip, then the motorcycle will move smoothly.

▲ CAUTION:

- After the rear wheel brake lever is released, do not rotate the throttle grip suddenly to prevent the motorcycle from rushing out.
- During riding, do not accelerate or decelerate rapidly and suddenly to save fuel and prolong the motorcycle service life.

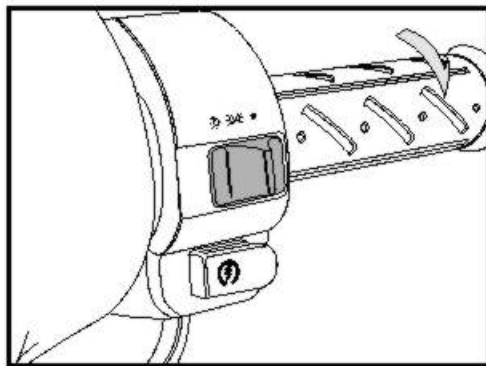

7. PRECAUTIONS FOR RIDING

(1) CORRECT RIDING

- Before moving, turn on the turn signal light and make sure whether the rear side is safe.
- Do not rush into the car lanes and always keep the motorcycle to the right to avoid danger.

▲ CAUTION:

- Moderate riding will prolong the engine service life. The clutch linings are worn more quickly when often ridden at low speed.

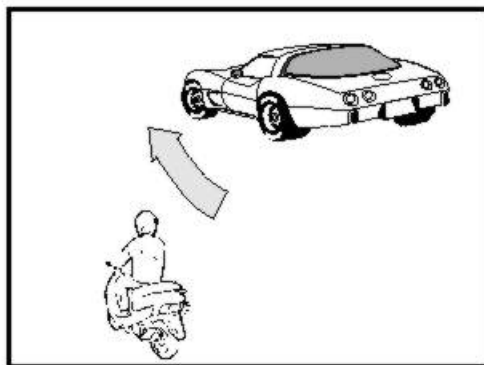

(2) SPEED CONTROL

- The speed is controlled by the throttle grip.
- ① ROTATE The speed will become faster. Don't be hasty and accelerate slowly.
When riding on an ascending road, rotate the throttle grip gradually to increase the horsepower.
- ② RESTORE The speed will become slower. Restore the throttle grip quickly.

▲ CAUTION:

- Apply the brake while restoring the throttle grip. This will shorten the time required to slow down.

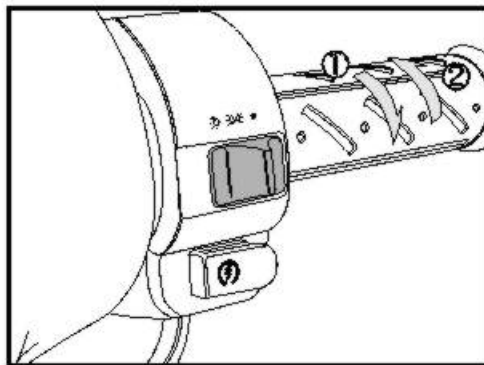

(3) PROPER RIDING WILL PROLONG THE SERVICE LIFE OF ENGINE

- For a new motorcycle, keep the speed below 40km per hour within the first 1000km of riding.
- Avoid sudden acceleration and long-time riding at high speed.
- In hot weather, the engine overheats easily at long-time idling. Stop the engine in this case.

▲ CAUTION:

- Moderate riding will prolong the engine service life.



(4) APPLY BOTH FRONT AND REAR BRAKES WHEN BRAKING

- First restore the throttle grip to the closed position and then pull the brake levers tight.
- The best way to brake the motorcycle is to pull the brake levers "slowly" at the very beginning, then pull them tight.

▲ CAUTION:

- Apply single brake lever will cause the motorcycle to slip.
- During riding, never brake the motorcycle suddenly. It may cause the motorcycle to slip and could be very dangerous.

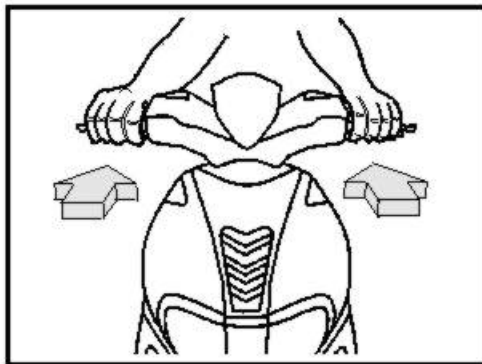

(5) DO NOT MAKE SUDDEN STOP OR SHARP TURN

- Sudden stop and sharp turn are the main causes for slipping and could be very dangerous.
- In rainy days the road is slippery. Sudden stop will cause the motorcycle to slip. Be careful to avoid danger.

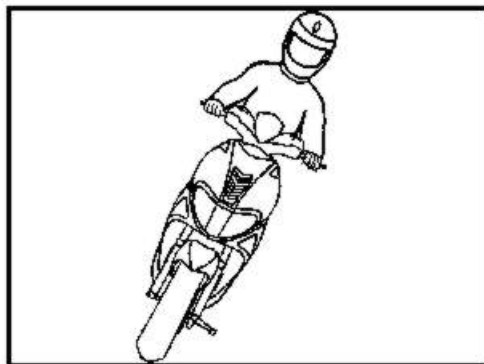

(6) BE MORE CAREFUL WHILE RIDING IN RAINY DAYS

- A longer braking distance is required in rainy days than in sunny days. Be sure to slow down and brake the motorcycle slowly as early as possible.
- When riding on a descending road, restore the throttle grip to closed position and slow down by making intermittent braking.

▲ CAUTION:

- A longer braking distance is required in rainy days. Be sure to slow down and brake the motorcycle slowly as early as possible.



8. HOW TO STOP RIDING

(1) WHILE GO NEAR THE PARKING PLACE

- Turn on the turn signal light in advance. Watch out vehicles coming behind or aside and stop the motorcycle to the right side slowly.
- Restore the throttle grip to closed position and apply the front and rear brakes as early as possible.
- At this moment, the stoplight will come on to warn the vehicles coming behind.

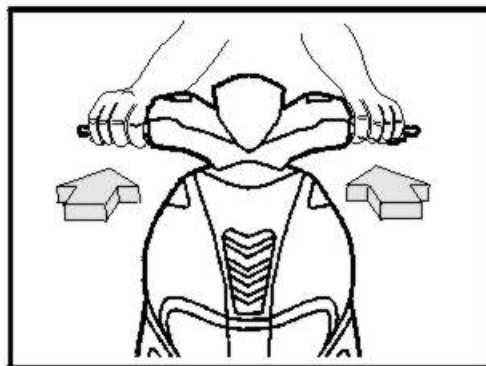

(2) WHILE THE MOTORCYCLE IS COMPLETELY STOPPED

- Return the turn signal switch to its original position.
- Turn the ignition switch "OFF" to stop the engine.

▲ CAUTION:

- During riding, never operate the ignition switch key.
- When the ignition switch is turned "OFF", the electric system does not work which may result in traffic accident. Operate the switch key after the motorcycle is fully stopped.



(3) PARKING

- Place the motorcycle on its main stand on level ground and do not hinder the traffic.
- Stand on the left side and grip the handlebar straight with left hand and the side rod or rear carrier with right hand. Then, step down the main stand evenly with right foot and pull the motorcycle backward by force with right hand.

▲ CAUTION:

- The motorcycle may easily fall down if it is parked on an uneven ground.

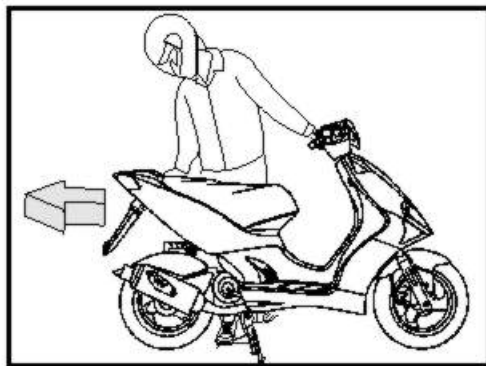

(4) HANDLEBAR

- After parking, be sure to lock the steering handlebar and take out the key to prevent pilferage. (Refer to P5.)

▲ CAUTION:

- Don't park your motorcycle at a place to hinder the traffic.
- The temperature of engine and exhaust muffler is very high. Be careful to avoid scalding.
- Park the motorcycle at a safe place and be sure to take out the key to prevent pilferage.



9. EASY MAINTENANCE

(1) AIR CLEANER INSPECTION AND AIR CLEANER CLEANING & REPLACEMENT

- Take out the air cleaner and visually check if it is dirty or clogged.
 1. Remove the screws attaching the air cleaner cover and remove the air cleaner cover.
 2. Remove the air cleaner element.
 3. The installation sequence is the reverse of removal.
- Wash the air cleaner element in detergent oil, squeeze out and allow to dry. Soak the element in clean engine oil SAE30# and squeeze out the excess oil. Then install it and the air cleaner.
- Replace the air cleaner element at every 2000km.
- The air cleaner requires more frequent cleaning or replacing when ridden in unusually dusty areas. When replacing, refer to P39 Periodic Inspection & Maintenance Schedule.

▲ CAUTION:

- Never use gasoline or vaporable oil for washing.
- Be careful not to allow water to enter the air cleaner; otherwise, it may result in hard starting.
- If the air cleaner is not installed properly, dust may be sucked into the cylinder directly to reduce engine horsepower and service life.

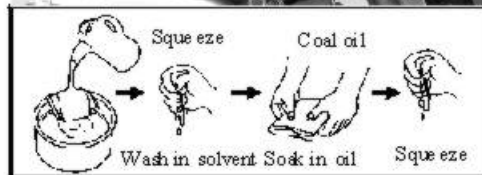

(2) FUEL SYSTEM

- Fuel and Motor Oil Leakage Inspection

Check the fuel line between the fuel tank and carburetor for fuel leakage.

- ① Fuel tube connector
- ② Fuel tank

▲ CAUTION:

- Check and replace any broken or damaged tube connector to avoid break down due to running out of gasoline or motor oil.

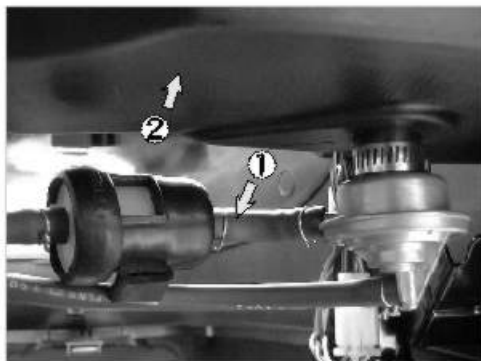

(3) APPEARANCE CLEANING

- Often wipe clean the motorcycle appearance to prevent accumulated dust affecting the function of components.

▲ CAUTION:

- If a motorcycle is not used for a long time, check the operation of each part and replace lubricants before riding. Ride the motorcycle only after its performance is confirmed.
- When waxing the motorcycle, make sure that the ingredients of the wax will not damage the paint of the motorcycle.



(4) BATTERY

- This model adopts the battery which needs no refilling of distilled water.
- When cleaning the terminal terminals, remove the screws attaching the battery cover on the floor board and then open the battery cover.
- When battery terminals are corroded, take out the battery for cleaning.
- After cleaning, apply a thin coat of grease or Vaseline to battery terminals and then install the battery.

▲ CAUTION:

- Never open the closed-type battery electrolyte cap.
- If the motorcycle will not be used for a long time, the battery will discharge electricity by itself. Remove the battery and put it in a cool place after it is fully charged to prevent electricity leakage.
- If the motorcycle will not be used for a long time, remove the negative (-) terminal.
- Do not smoke or allow flames or sparks near the battery while removing and installing it.
- Turn off the ignition switch before removal or installation. The negative (-) terminal shall be removed first and the positive (+) terminal shall be installed first.
- Tighten the loose terminal nuts securely.

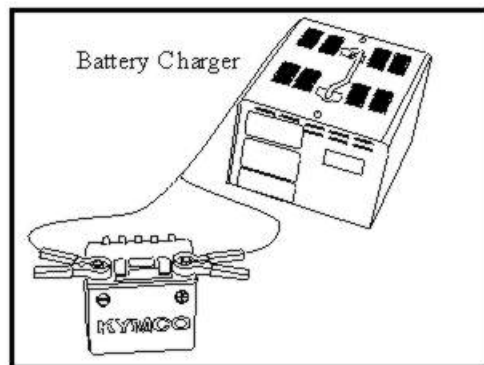
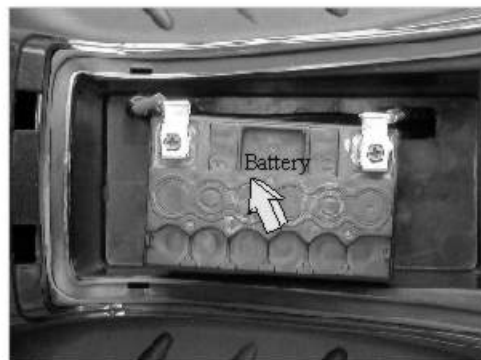

(5) FUSE CHANGE

- Turn off the main switch and check if the fuse is burned out.
- When the fuse is burned out, replace with a specified fuse.
- Check for the cause of breakdown before replacing.

① Battery Fuse Specification: 15A

② Ignition Switch Fuse Specification: 7A

▲ CAUTION:

- Be careful not to excessively expand the fuse clip during removal.
- After a new fuse is installed, check the fuse clip for looseness which is the main cause of trouble.
- Never use fuse of unspecified capacity, it may cause wire overheating and burning out.
- When replacing electric appliances (lights, instruments), be sure to use the recommended genuine parts.
- When washing the motorcycle, avoid flushing it.
- If the cause can not be found, contact our distributor or service station for inspection.

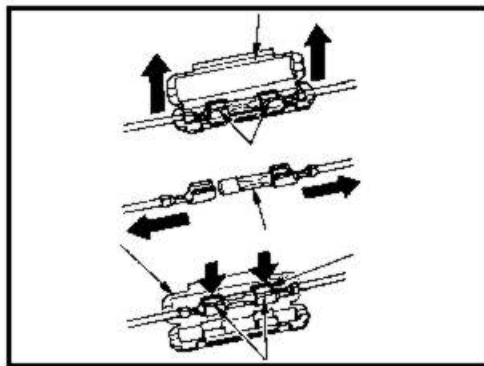

(6) TRANSMISSION GEAR OIL

- Check the transmission gear oil tank for leakage.
 - 1. Place the motorcycle on its main stand on level ground.
After the engine stops for 2~3 minutes, remove the gear oil check bolt to check the oil level.
 - 2. If the oil level is lower than the check bolt hole lower edge, add gear oil to the lower edge.
 - 3. After refilling, securely tighten the check bolt.
 - Recommended Gear Oil: SAE90
 - Capacity / Exchanging Capacity: 0.12 L / 0.10 L
- ① Gear Oil Filler Oil (Check Bolt Hole) ② Drain Bolt
③ Oil Level

▲ CAUTION:

- Add gear oil through the oil check bolt hole.
- After refilling, use a rag to wipe clean.
- Excess or insufficient gear oil will affect the engine performance.
- Never use gear oil of different brand or inferior quality which may result in engine breakdown.
- Change gear oil at first 300km and then change at every 5000km. Add specified gear oil whenever it is necessary.

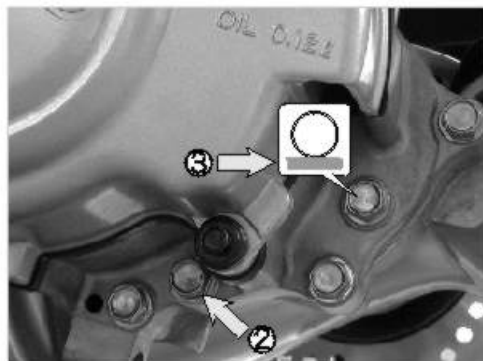

(7) SPARK PLUG INSPECTION

- Check the spark plug side electrodes for wear.
 - Fouling deposits on spark plug electrodes and big gap may result in weak spark.
 - Spark Plug Removal:
 - 1.Remove the spark plug with a spark plug remover.
 - 2.The installation sequence is the reverse of removal.
 - Spark Plug Cleaning:
 - 1.It is better to remove spark plug deposits with a spark plug cleaner.
 - 2.If a spark plug cleaner is not available, clean with a wire brush.
 - The side electrode gap is 0.6~0.7mm.
 - Specified Spark Plug: NGK-BR8HSA
- ① Decarbonizing ② Cracks, Damage ③ Gap, Wear, Fouling Deposits

▲ CAUTION:

- Clean the spark plug at every 3000km and replace it with a new one at every 5000km or when the center electrode is burned out.
- First screw in the spark plug with fingers and then tighten with a spark plug wrench.
- Use unspecified spark plug may damage the engine.

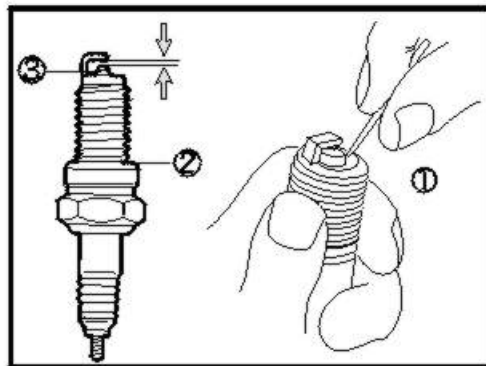

(8) BRAKE FLUID LEVEL INSPECTION /REFILLING

- Remove the 2 screws from the brake fluid tank and take off the cover.
- Add recommended brake fluid DOT 3 into the tank until the fluid level reaches the upper limit and then put on the cover and tighten the screws.
- Recommended Brake Fluid: DOT 3

▲ CAUTION:

- Do not mix brake fluid of different brands. It may cause brake failure and is very dangerous. When refilling brake fluid, use towels to cover and protect the painted and coated surfaces. (Replace at 10000km or every year.)

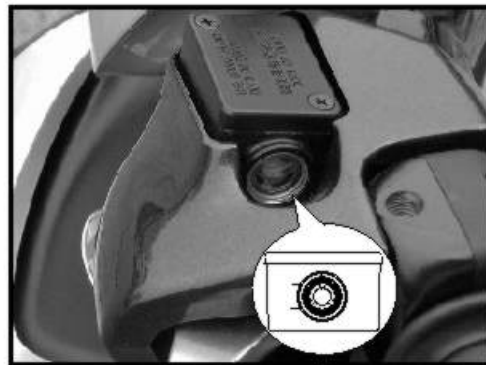
**(9) RUBBER COVER INSPECTION FOR WIRE AND CABLE**

- The cable cores are protected by the rubber cover outside the connector. Check the rubber cover frequently for proper installation.
- When washing the motorcycle, do not flush the rubber cover directly or brush it. Use a wet rag to wipe off dirt and dust.

① Rubber Cover

② Check Points

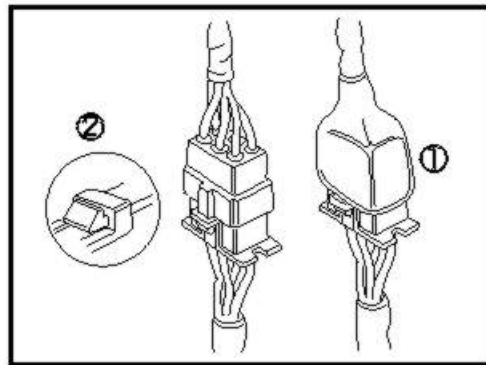

(10) COOLANT REFILLING

1. Place the motorcycle on its main stand on level ground.
2. Remove the reserve tank cap and fill to the upper level line with distilled water.

- If the coolant level is too low, it means that there are abnormal conditions.
- Coolant concentrate specified density: 30% (cold area 50%)

Density & Freezing Point:

25% : -12 °C 40% : -24 °C

30% : -15 °C 50% : -35 °C

Total coolant capacity : 1165cc.

① Reserve tank cap

② Reserve tank eye hole

▲ CAUTION:

- Use distilled water to make coolant mixture.
- Be careful not to use coolant of inferior quality which may shorten the radiator service life.
- Replace the coolant once a year or at every 10000 km under normal use.

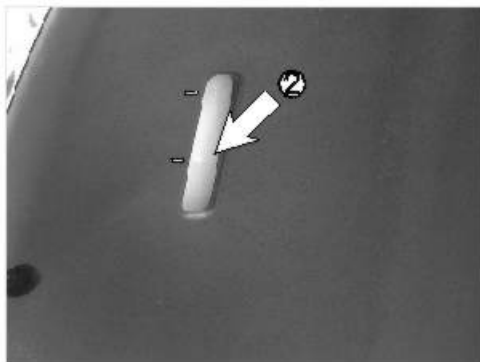
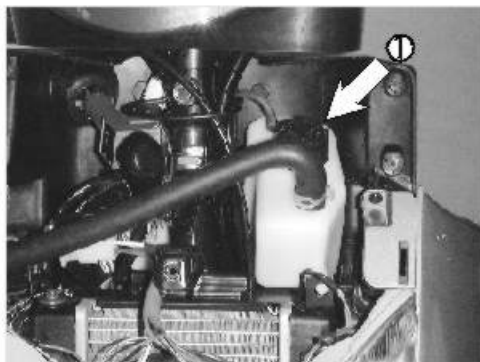

(11) COOLANT REPLACEMENT

Coolant Draining

1. Remove the front cover.
2. Press down the reserve tank cap and turn it counterclockwise to remove it.
3. Remove the hose water It to drain the coolant. Tilt the motorcycle to the right and the coolant will drain more easily.

Coolant Filling

1. Install the hose water and reserve tank.
2. First fill the reserve tank with coolant to the upper level line.
3. Install and securely tighten the reserve tank cap.
4. Start the engine and allow the cooling fan to run for at least 2 times. Then, stop the engine. (The engine must be cool before removing the reserve tank cap, or severe scalding may result.)
5. Remove the reserve tank cap and add coolant up to the proper level if necessary. Then, reinstall the reserve tank cap.
6. Wait for 2 ~ 3 hours until the engine is cold. Check the coolant level in the reserve tank and fill to the upper level line if the level is under the lower level line.

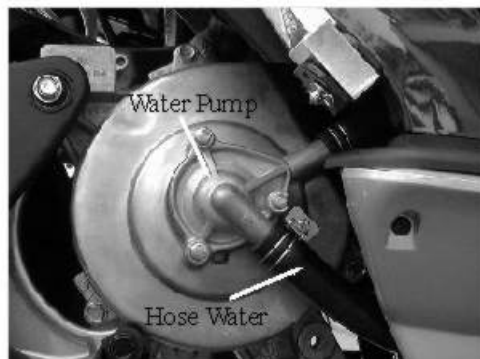

CAUTION:

- When removing the reserve tank cap, be more careful because the coolant is under pressure and severe scalding could result. Wait until the temperature is lowered. Then, cover the reserve tank cap with a towel and then remove it slowly.
- Avoid spilling coolant on painted surfaces. Once it happens, immediately flush with fresh water.

10. IMPORTANT NOTICES

(1) WHEN THE ENGINE FAILS TO START OR STOPS DURING RIDING

- Is the gasoline enough?
- If the fuel gauge pointer is at the red line, refill #92 or #95 nonleaded gasoline.
- Is the way to start the engine correct?
- Is there any other faulty parts?



(2) IN CASE OF BREAKDOWN

- For any trouble occurred during riding, go to a KYMCO distributor or service station for inspection.

CAUTION:

- For the sake of safety and to prevent vehicle damage and save your precious time, the pre-ride inspection is absolutely required. Please read this User's Manual carefully and get into a good habit of inspection before riding.

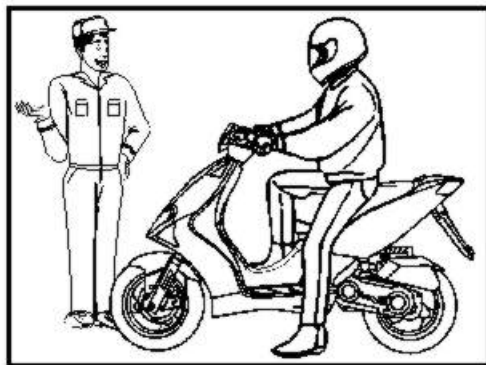

(3) POLLUTION-FREE PERIODIC MAINTENANCE SCHEDULE

- In order to have a safe riding, maintain good performance, prolong the motorcycle service life and reduce pollution, make sure to perform the periodic inspection and maintenance.

I: Inspect and clean, lubricate, refill, repair or replace if necessary.

A: Adjust **C:** Clean **R:** Replace **T:** Tighten

Item	✓		Regular Service Mileage (KM)								Daily Pre-ride Inspection
	2Stroke	4Stroke	300	1000	3000	5000	7000	9000	11000	13000	
✓ Engine Oil	X	○	R	R	R	R	R	R	R	R	I
✓ Engine Oil Strainer	X	○	C		C		C		C		
✓ Gear Oil	○	○	R		R		R		R		
✓ Cooling Water	○	○	• Clean at every 10000km or once a year.								I
✓ Spark Plug	○	○	• Clean (C) at every 3000km or replace (R) if necessary.								
✓ Valve Clearance	X	○	A		A		A		A		
✓ Carburetor	X	○			I		I		I		
✓ Drive Belt	○	○					I			I	
✓ Drive Chain	○	○		A	A	A	A	A	A	A	
✓ Air Cleaner	○	○		I	R	I	R	I	R	I	
✓ Battery Electrolyte	○	○		I	I	I	I	I	I	I	I
✓ Fuel Filter Screen	○	○					R				
✓ Brake System	○	○		I	I	I	I	I	I	I	I
✓ Clutch Lever Free Play	○	○	A		A	A	A	A	A	A	
✓ Bolts & Nuts	○	○	T			T			T		
✓ Tire Pressure	○	○		I	I	I	I	I	I	I	I
Motor Oil Strainer	○	X									
Engine Oil Pump	○	X	I		I		I		I		

• The above items are applicable to different models. Perform suitable items for each model.
 • When exceeding the listed mileage, perform maintenance according to the listed intervals.
 • The air cleaner requires more frequent cleaning or replacing when ridden in unusually dusty areas.

(4) SPECIFICATIONS

Engine Type	water cooled 2-cycle	Overall Length	1850 mm
Displacement	49.4 cc	Overall Width	700 mm
Bore x Stroke	39.0x41.4 mm	Overall Height	1190 mm
Compression Ratio	7.2 : 1	Dry Weight	102 kg
Max. Output	2.72/6500 kw/rpm	Wheel Base	1295 mm
Max. Torque	0.4/6000 kg-m/rpm	Ground Clearance	160 mm
Tire Size	FR:120/70-12 RR:130/70-12	Fuel Type	#92 or 95 nonleaded gasoline
Transmission Type	Non-stage transmission	Spark Plug	NGK-BR8HSA
Clutch	Dry Multi-Disc Clutch	Oil Tank Capacity	1.4 liter
Ignition	C.D.I.	Fuel Tank Capacity	7.0 liter
Starting System	Starting motor and kick starter	Gear Oil Type Capacity/Change	SAE 90 0.12 L/0.10 L
Idle Speed	2000 rpm	Battery	12V4AH



5 Stan Perkins Road

Spartanburg, SC 29307

Telephone: (888) 235-3417

FAX: (864) 327-4745

Free Manuals Download Website

<http://myh66.com>

<http://usermanuals.us>

<http://www.somanuals.com>

<http://www.4manuals.cc>

<http://www.manual-lib.com>

<http://www.404manual.com>

<http://www.luxmanual.com>

<http://aubethermostatmanual.com>

Golf course search by state

<http://golfingnear.com>

Email search by domain

<http://emailbydomain.com>

Auto manuals search

<http://auto.somanuals.com>

TV manuals search

<http://tv.somanuals.com>