

LEADER TEST INSTRUMENTS

MODEL LDC-822 • LDC-822A

DIGITAL COUNTER

INSTRUCTION MANUAL

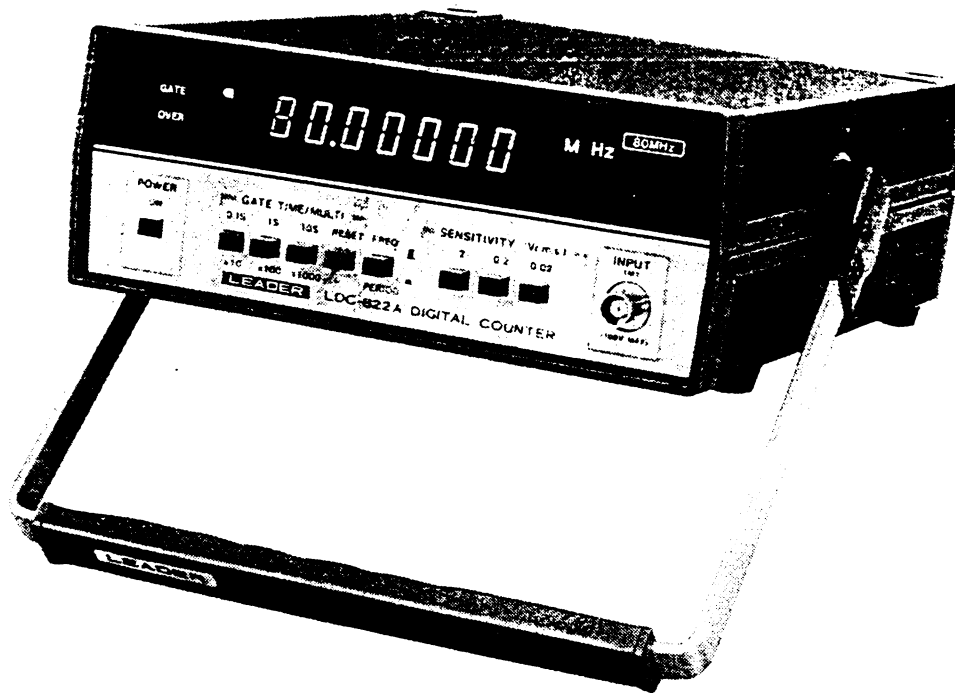

LEADER ELECTRONICS CORP.

LDC-822 · LDC-822A

DIGITAL COUNTER

1. Introduction

LDC-822(A) is a digital frequency counter/timer designed to measure the frequency and period of a signal, featuring a wide frequency range 10Hz–80MHz, a high input sensitivity (20mV) rms, and high resolution to 7 digits. The period function makes the unit outstanding for video tape recorder service applications. This instrument can be used for adjustment, test and repair of audio instruments, AM/FM radios, TVs, CB radios, computer clocks, amateur-radios, electronic watches, and musical instruments, etc. The LDC-822(A) is small and portable. A big bright fluorescent display assures easy readability of values. The green display does not induce eye fatigue even after an extended period of viewing. Readout miscounts are reduced by zero-blanking, unit-display (kHz, MHz, mS) and overrange display. The use of LSI and MSI in the internal circuit assures reliable performance and less power consumption.

2. Specifications/Ratings

Frequency Measurements

Range	10Hz – 80MHz
Gate time	0.1S, 1S, 10S
Resolution	10Hz, 1Hz, 0.1Hz
Accuracy	±1 count, ± time base accuracy

Period Measurements

Range	100mS – 1μS
Multiplication Factors	×10, ×100, ×1000
Resolution	10μS, 1μS, 0.1μS
Accuracy	±1 count, ± time base accuracy, ± trigger error

Input Section

Input sensitivity	20mVrms, 200mVrms, 2Vrms (10Hz – 80MHz)
Attenuator	1, 1/10, 1/100
Coupling	AC
Input impedance	approx. 1MΩ
Maximum input voltage	10Hz – 400Hz : 100Vrms 400Hz – 100kHz : 20Vrms 100kHz – 80MHz : 5Vrms

Time base

Frequency	10MHz (crystal controlled)
Accuracy	±5 × 10 ⁻⁶ (32°F – 104°F) (0°C – 40°C)

General Specifications

Display	7 digits, 7 segment fluorescent display overflow indication, gate indication and zero blanking
Operating temperature range	0°C – 40°C (32°F – 104°F)

Power source	100V, 117V, 200V, 234V \pm 10% 50Hz – 60Hz (Voltage-change is accomplished by change on tap of transformer)
Power consumption	Approx. 10VA
Dimensions	3"(H) \times 8" (W) \times 10"(D) excluding knobs and legs
Weight	approx. 5 lbs.
Accessories	clip cable with BNC connector

3. PANEL FUNCTIONS

3.1 Front Panel

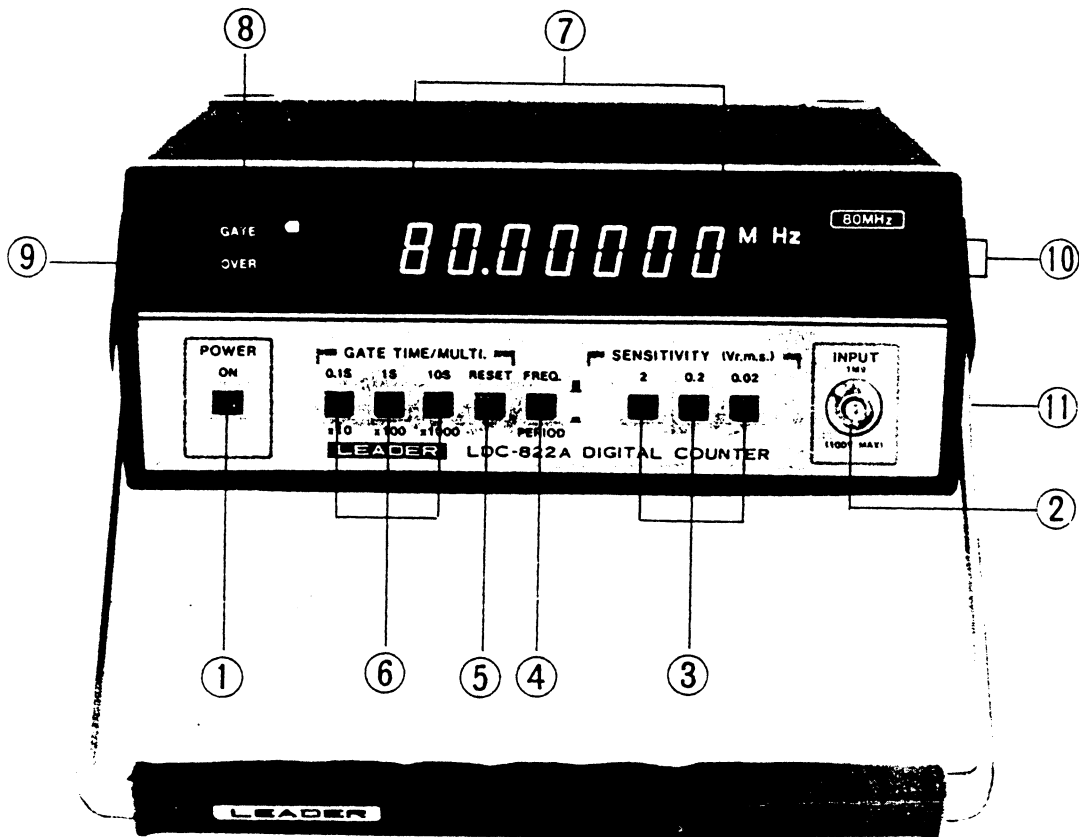

Fig. 3-1

Fig. 3-1 shows the front panel of LDC-822A.

- ① Power switch:
To turn on, depress push-button, to turn off, again depress push button.
- ② INPUT Terminal:
BNC Connector
- ③ SENSITIVITY Selector:
3 push button switches for 20mV, 200mV, 2V respectively
- ④ Function Switch:
A push button switch for changing the measurement mode, used for selecting the measurement functions of PERIOD and FREQ.

- ⑤ **RESET Switch:**
By pressing this switch, the counter stops its operation, and during the time that the switch is depressed, the display is continuously shown. When released, the display is cleared to zero. After a delay of approximately 0.1S, if there is an input signal, the counter starts counting.
- ⑥ **GATE TIME; MULTIPLIER SELECTOR:**
For frequency measurement, this switch is used to change GATE TIME; when in the period-measurement mode, it is used to change the multiplier factors. Each range is as follows:
- | | |
|------------|------------------------|
| GATE TIME: | 0.1, 1 and 10 sec. |
| MULTI.: | × 10, × 100 and × 1000 |
- ⑦ **Display:**
It is a 7 digit, 7 segment, fluorescent display. In accordance with the measuring range, the decimal point is displayed automatically, and the leading zeros are blanked.
- ⑧ **GATE indicator:**
Displays the opened or closed state of the GATE. When GATE is open, indicator is lit.
- ⑨ **OVERRANGE indicator:**
Lights when the frequency is over the counting capacity of 7-digits. In the case of overrange, push the GATE TIME/MULTIPLIER switch to smaller values until the overrange indicator light goes off.
- ⑩ **Unit Indicator:**
For frequency measurement, the indicator shows "MHz" at 0.1S; and "kHz" at 1S and 10S. "mS" is displayed in the case of period measurements.
- ⑪ **Handle/Stand combination:**
The lock of the handle can be released by pressing the mounted part of the handle on both sides with both hands. The handle can then be freely rotated. When the hand is released, it is locked in a position of 60° – 120° – 180° – 240° – 300° or 360°.

3.2 Rear Panel:

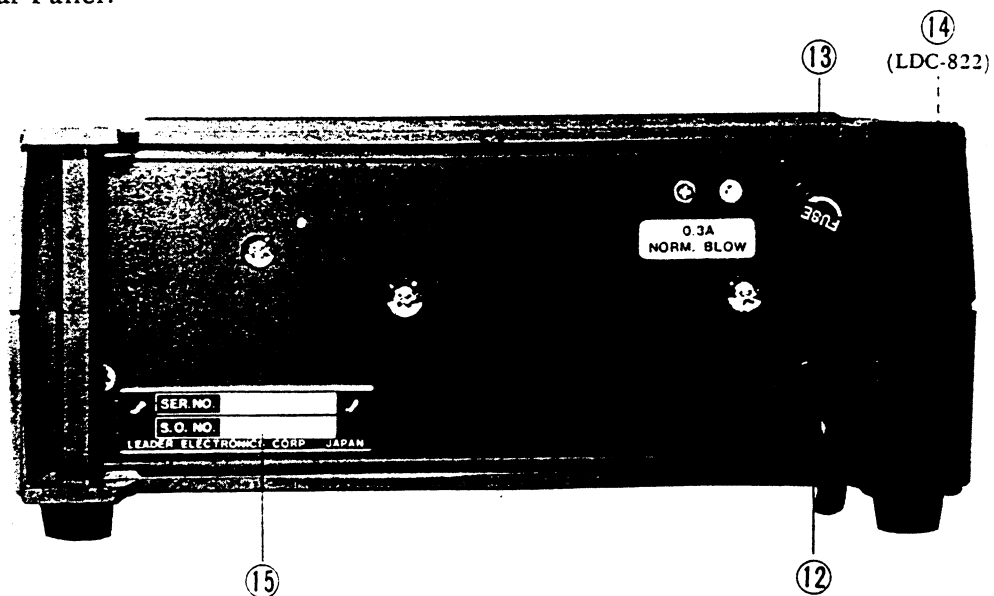

Fig. 3-2

- ⑫ Power cord
- ⑬ Fuse holder (contains 0.3A fuse)
- ⑭ Stand legs (LDC-822)
There are four legs on the stand for keeping the LDC-822 in the vertical position. The power-cord can be coiled when not in use.
- ⑮ Label

3.3 Diagram of the base

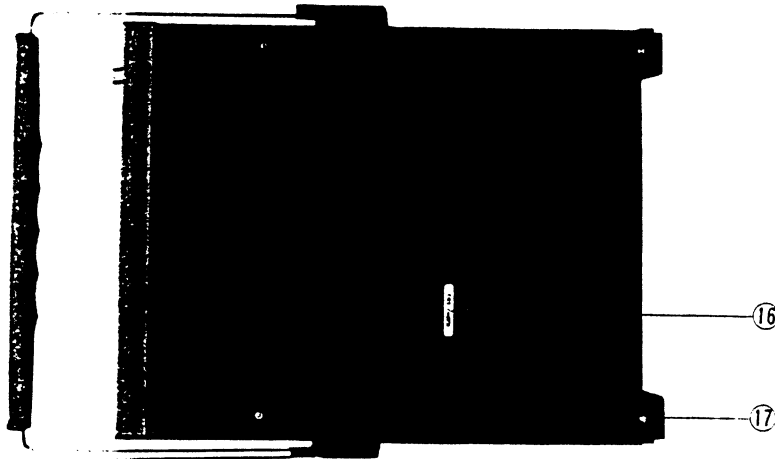

Fig. 3-3

- ⑯ With a screw driver, trimmer control adjustments of the reference frequency oscillator can be made. For procedure, refer to section 6 – Maintenance.
- ⑰ Rubber feet

4. Operating Instruction

4.1 Precautions in use

1. In connecting the instrument to the device (to be tested), particularly in an internal connection, remove all AC power to the device, and remove the cord. After discharging all charged capacitors, connect the cable for measurement, thus, the danger of an electrical shock can be minimized. Take the same care in disconnecting the input cable.
2. Use AC-power source of LDC-822(A) at 50 – 60Hz, within 10% of rating voltage. Caution: Excessively large or small AC-voltages may induce erroneous operation.
3. In replacing the fuse, use the designated 0.3A-fuse.
4. Avoid all the severe mechanical shocks to crystal-oscillator or fluorescent indicators.

4.2 Fundamental Operation

1. Disconnect the input cable of the LDC-822(A).
2. Connect the AC-power cord to the proper AC-power source.
3. Set POWER switch to the ON position.
4. Set the function switch to FREQ.
5. Set the SENSITIVITY-selector to 2V.

6. Put the GATE TIME Selector at 0.1S.
Confirm the display of "0.00000MHz." There is no display on the left-ward 1st digit of the decimal point. The GATE indicator is lighted for 0.1S while the gate is open, and disappears for 0.1S while the gate is closed.
7. Set GATE TIME selector at 1S, in this case, the display shows 0.000kHz, and GATE indicator shows the repeating 1S light-on/0.1S light off.
8. Press the 10S GATE Selector.
Display of left-most 2 digits disappears, revealing 0.0000kHz, and GATE indicator repeats 10S light-on/about 0.1S light-off.
9. Set the FUNCTION-switch to PERIOD.
10. Use the "MULTI" scales, and confirm the display as shown in Table 4-2-1. In the case that the displayed figure shows other than 0 (zero), or when GATE indicator is lighted, push the reset switch, then. GATE indicator disappears (gate is closed), and the display shows as in Table 4-2-1.

MULTI	Display
X10	0.00 mS
X100	0.000 mS
X1000	0.0000 mS

Table 4-2-1

11. In the above 6–10 OVER-flow indicator always shows light off.

4.3 Input Connections

Connect BNC Connector of the accessory-cable to the input-terminal. Connect the ground – negative side of the clip to the (common) of the device under test. connect the positive hot side to the test point. The input AC only (DC blocked by 0.1 μ F capacitor). The maximum allowable voltage of the AC component of the input signal depends on frequency, the values are as follows:

10Hz – 400Hz	100Vrms or 280Vp-p
400Hz – 100kHz	20Vrms or 56Vp-p
100kHz – 80MHz	5Vrms or 14Vp-p

The maximum voltage of the DC component of the input signal is ± 100 V DC. When the input signal is not a continuous sine-wave or is modulated, the following values are the maximum allowable AC input voltages permitted in accordance with the frequency chart below.

10Hz – 400Hz	250Vp-p
400Hz – 100kHz	56Vp-p
100kHz – 80MHz	14Vp-p

CAUTION NOTE: Caution should be taken not to get an electric shock when connecting or removing the input cable. High voltage-circuits and horizontal output pulses of flyback transformers in TV-sets generate excessive voltages. The LDC-822(A) could be damaged by exceeding input limitations. Therefore, never make a direct connection to these circuits.

The input impedance of this instrument is approx $1M\Omega$ and shunted by approximately $30pF$. The input cable has a distributed capacity of approx $70pF$. This total ($100pF$) should be considered when making critical measurements.

Note: Do not connect the input of LDC-822(A) to a high impedance-point of the device under test. The parallel effects of this $1M\Omega/100pF$ combination affects the operation of the circuit being tested.

4.4 Setting of input sensitivity

1) Input sensitivity and noise

The input-sensitivity of LDC-822(A) can be selected from $0.02V_{rms}$, $0.2V_{rms}$, or $2V_{rms}$, in order to measure input signals of wide voltage-ranges. When a large signal is applied to the input at the higher input-sensitivity, the noise included in the input signal may induce miscounting. In this case, reduce the input sensitivity to the appropriate input range as listed in Table 4-4-1. This minimizes errors.

Input sensitivity of counter	Range of input voltage
$0.02V_{rms}$	$0.02 - 0.2V_{rms}$
$0.2V_{rms}$	$0.2 - 2V_{rms}$
$2V_{rms}$	$2 - 20V_{rms}$

Table 4-4-1

2) Measurements of Modulated Signals

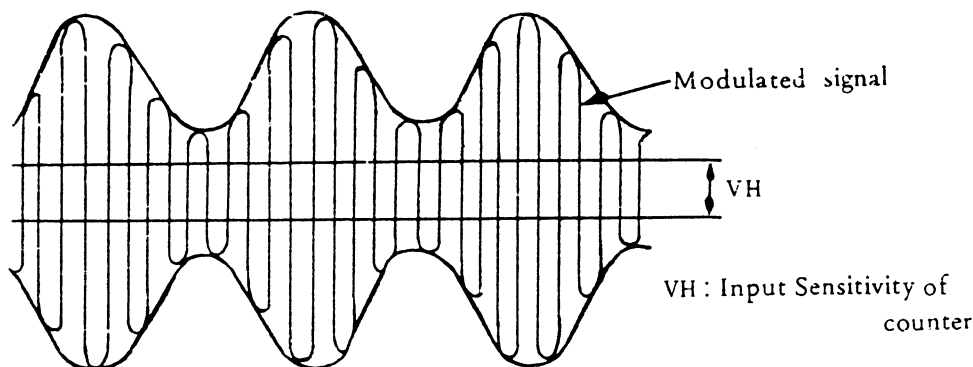

Fig. 4-4-2

As seen in the above Fig. 4-4-2, in order to measure the frequency of modulated carrier-wave, if the voltage of highest modulated part is greater than the input sensitivity VH ($0.02V_{rms}$), it is then possible to count the carrier-wave.

4.5 Frequency-measurement

Set the function-switch to **FREQ.**, apply signal to the input terminal. The measuring range is $10Hz - 80MHz$. By setting the **GATE** time to the values shown in Table 4-5-1, measurement can be done at the maximum resolution without overrange.

Gate Time	Measuring frequency	Display
10 S	$10Hz - 999.999kHz$	$0.0100kHz - 999.999kHz$
1 S	$10Hz - 9999.999 kHz$	$0.010kHz - 9999.999kHz$
0.1S	$10Hz - 80.00000MHz$	$0.00001MHz - 80.00000MHz$

Table 4-5-1

In measuring the frequency of 10Hz – 1kHz at a high resolution, period-measurement is more suitable.

4.6 Period measurement

- 1) Set the function switch to PERIOD, and apply the signal to the input terminal. The measuring range is 100mS – 0.001mS (1 μ S). Period-measurement is suitable for accurate measurement in the frequency range of 10Hz – 1kHz.

By setting the MULTI and PERIOD as listed in Tables 4-6-1 and 4-6-2, more accurate measurements can be accomplished within a short time and longer numerical display measurement results in a more accurate measurement.

When the measuring time is within 1S – 0.1S,

Frequency	Period	MULTI	Display
10Hz–100Hz	100mS – 10mS	×10	100.00mS – 10.00mS
100Hz – 1kHz	10mS – 1mS	×100	10.000mS – 1.000mS
1kHz – 10kHz	1mS – 0.1mS	×1000	1.0000mS – 0.1000mS

Table 4-6-1

When the measuring time is within 10S – 1S.

Frequency	Period	MULTI	Display
10Hz – 100Hz	100mS – 10mS	×100	100.000mS – 10.000mS
100Hz – 1kHz	10mS – 1mS	×1000	10.0000mS – 1.0000mS

Table 4-6-2

- 2) Measuring accuracy

The accuracy of period-measurement can be expressed as follows:

Accuracy = ± 1 count \pm trigger error, time base accuracy . . . Equation 4-6-1.

In the above equation, the most important factor is the trigger-error. Trigger-error occurs with the overlapped signal noise and noise in the counter. During the measurement, when the display fluctuating range is within ± 1 , the error can be regarded as ± 1 count. If it is over ± 1 count, it may be trigger-error or alteration of the input signal. As a checking method, when the input-sensitivity of counter or input-voltage is set to higher values, if the variable range becomes less, it can be judged as trigger error.

In order to reduce the effect of input signal noise the trigger-error can be reduced by raising the input voltage or by rectifying the input-wave into rectangular wave-form applying to LDC-822(A).

5. BLOCK DIAGRAM

LDC-822(A) DIGITAL COUNTER BLOCK DIAGRAM

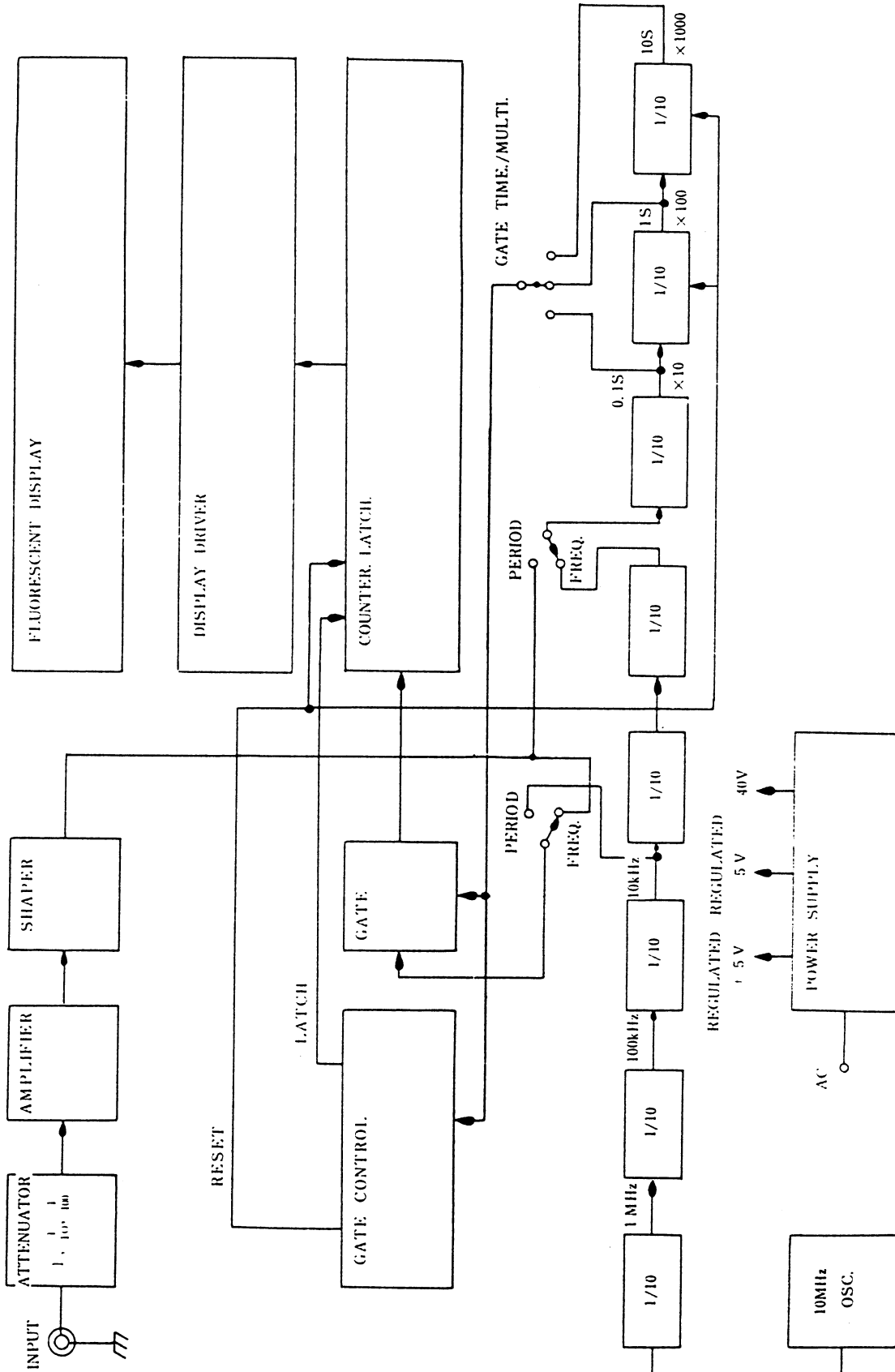

6. MAINTENANCE

1. To calibrate or make correction to the standard oscillator.
A standard oscillator with an accuracy greater than $\pm 1 \times 10^{-6}$ is required for calibration. Apply the output of standard oscillator to the input-terminal of LDC-822(A); measure the frequency. A normally operating counter displays 1MHz or 10MHz. If you read other than 1MHz or 10MHz, adjust the trimmer capacitor with the screw driver through the hole for adjustment provided at the base of the LDC-822(A), in order to make exact accurate display.
2. The LDC-822(A) has been designed for easy maintenance and high reliability by employing LSI/MSI IC's for the digital and power-source sections of this instrument.
3. If the instrument fails to perform in the manner specified herein, write or call your nearest Leader office for factory-trained service. For safety reasons, and to prevent damage to the instrument, DO NOT REMOVE the unit from the case.

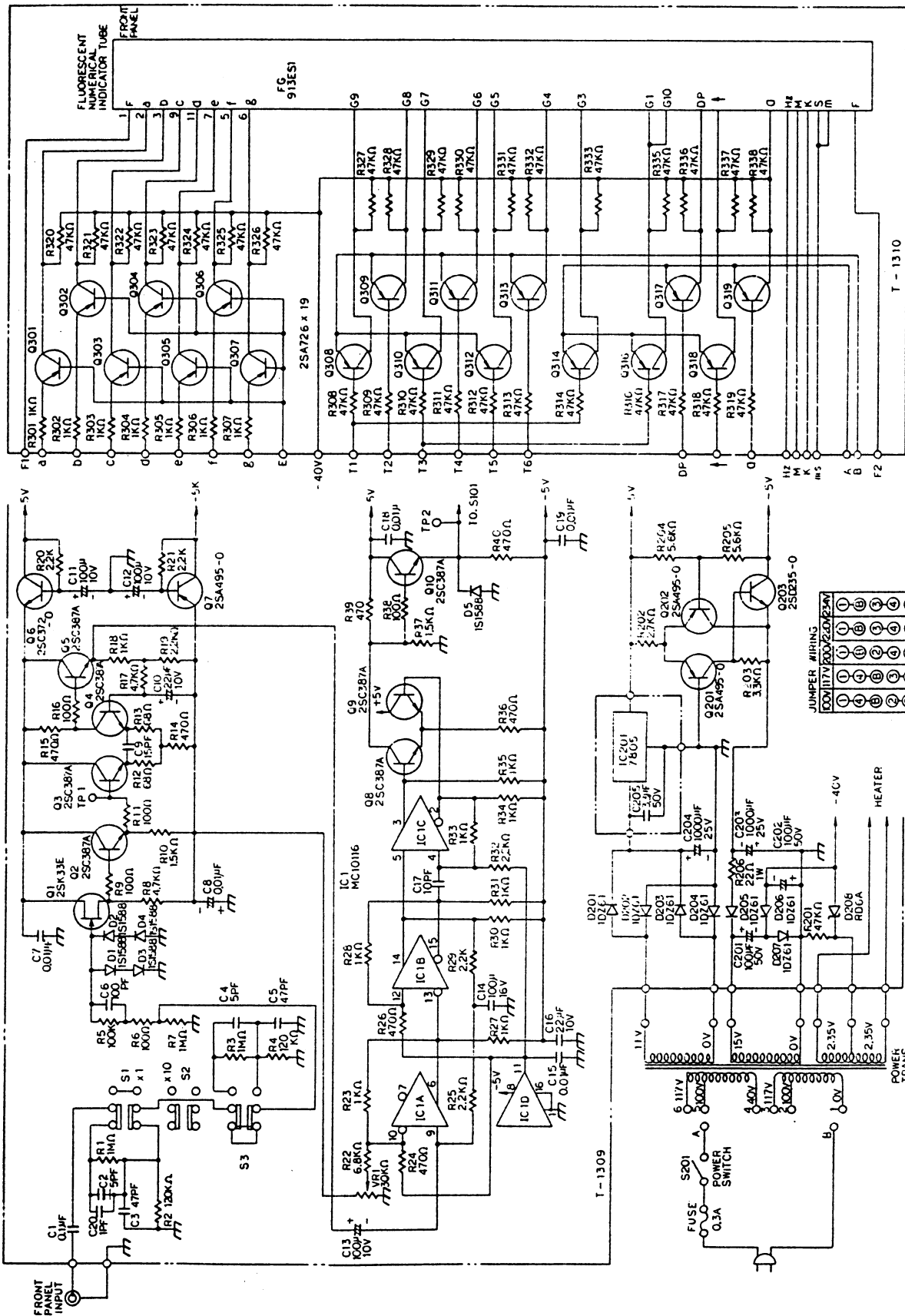

SCHEMATIC Model LDC-822 O-1002 (1/2) LEADER ELECTRONICS

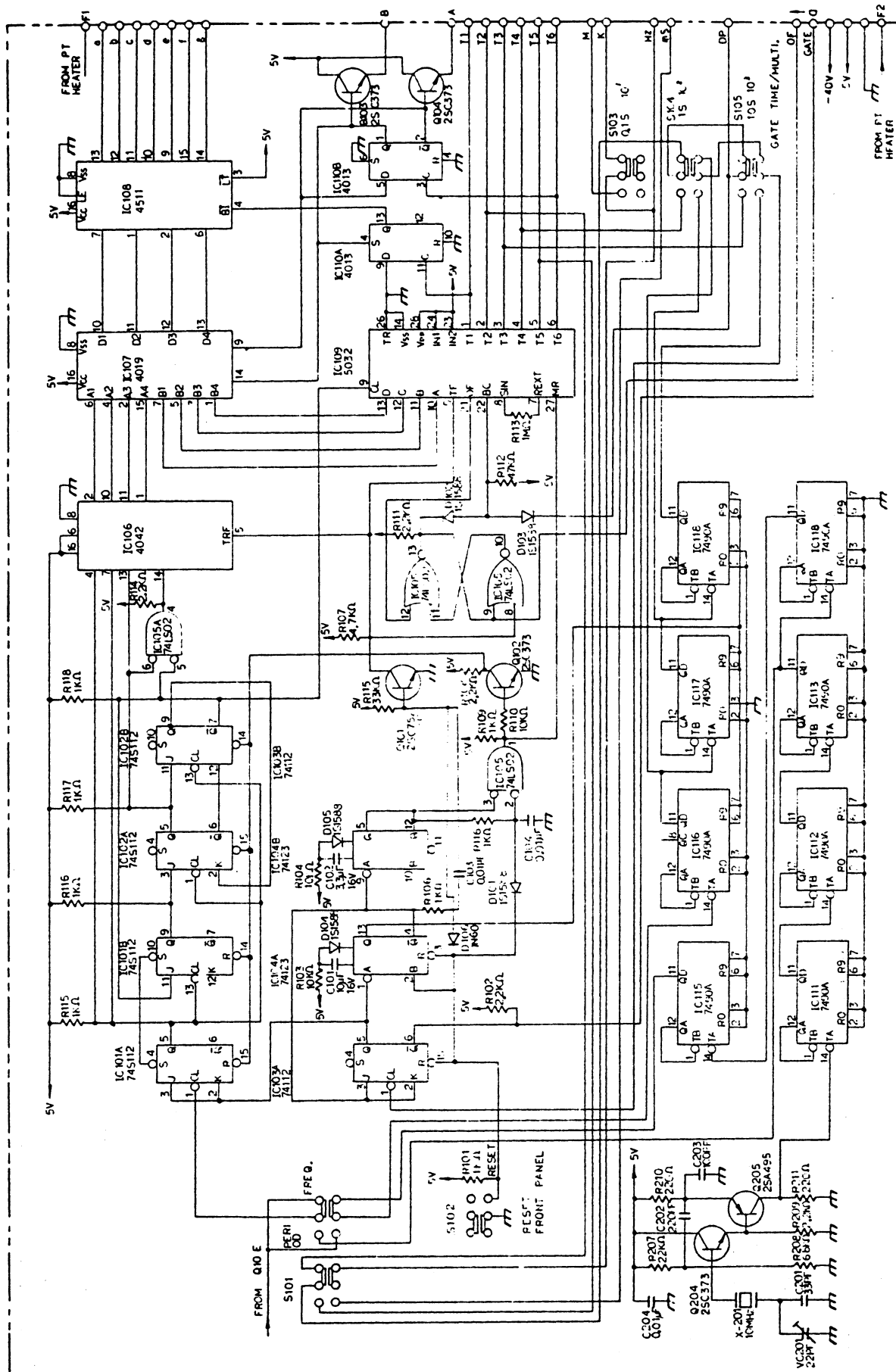

S. SCHEMATIC	Model LDC-822	0-1002 (2/2)
LEADER ELECTRONICS		

LEADER TEST INSTRUMENTS

LEADER ELECTRONICS CORP.

2-6-33 TSUNASHIMA-HIGASHI, KOHOKU-KU,
YOKOHAMA, JAPAN.

PHONE: (045) 541-2121 TELEX: J47780 JPLEADER

LEADER INSTRUMENTS CORP.

380 OSER AVENUE, HAUPPAUGE, N.Y. 11788 U.S.A.

PHONE: (516) 231-6900

TELEX: 510-227-9669 LEADER HAUP

Free Manuals Download Website

<http://myh66.com>

<http://usermanuals.us>

<http://www.somanuals.com>

<http://www.4manuals.cc>

<http://www.manual-lib.com>

<http://www.404manual.com>

<http://www.luxmanual.com>

<http://aubethermostatmanual.com>

Golf course search by state

<http://golfingnear.com>

Email search by domain

<http://emailbydomain.com>

Auto manuals search

<http://auto.somanuals.com>

TV manuals search

<http://tv.somanuals.com>