

Lenovo C2/C3 Hardware Maintenance Manual

lenovo

Contents

Chapter 1. About this manual	1	Chapter 7. Replacing hardware	21
Important Safety Information	1	General information	21
Chapter 2. Safety information	3	Hardware components	22
General safety	3	Replacing a memory module	26
Electrical safety	3	Replacing the optical drive	27
Safety inspection guide	5	Replacing the hard disk drive	29
Handling electrostatic discharge-sensitive devices	5	Replacing the keyboard and mouse	31
Grounding requirements	6	Replacing the power cord	32
Safety notices	6	Removing the speaker cover	32
Chapter 3. General information	9	Removing the computer cover	34
Specifications	9	Replacing the converter board	35
Chapter 4. General Checkout	11	Removing the computer stand	36
Problem determination tips	11	Removing the EMI cover	37
Chapter 5. Using the Setup Utility.	13	Replacing the system fan	38
Starting the Setup Utility program	13	Replacing the TV tuner card	40
Viewing and changing settings	13	Replacing the WLAN card	41
Using passwords.	13	Replacing the heatsink	42
Using Device	15	Replacing the CPU	44
Selecting a startup device	15	Replacing the rear I/O module	46
Exiting from the Setup Utility program	16	Replacing the speaker system	48
Chapter 6. Symptom-to-FRU Index	17	Replacing the motherboard.	49
Hard disk drive boot error	17	Replacing the camera	51
Power Supply Problems	17	Replacing the front indicator and power button board	52
POST error codes	18	Replacing the front function board	53
Undetermined problems	18	Replacing the LED panel.	54
		Chapter 8. Additional Service Information	57

Chapter 1. About this manual

This manual contains service and reference information for Lenovo C220/C225/C320/C325 computers listed on the cover. It is intended only for trained servicers who are familiar with Lenovo computer products.

Before servicing a Lenovo product, be sure to read the Safety Information.

The description of the TV card in this manual is only used for the machines which have the TV card. It is invalid for those machines which do not have TV card.

Important Safety Information

Be sure to read all caution and danger statements in this book before performing any of the instructions.

Veillez lire toutes les consignes de type DANGER et ATTENTION du présent document avant d'exécuter les instructions.

Lesen Sie unbedingt alle Hinweise vom Typ "ACHTUNG" oder "VORSICHT" in dieser Dokumentation, bevor Sie irgendwelche Vorgänge durchführen

Leggere le istruzioni introdotte da ATTENZIONE e PERICOLO presenti nel manuale prima di eseguire una qualsiasi delle istruzioni

Certifique-se de ler todas as instruções de cuidado e perigo neste manual antes de executar qualquer uma das instruções

Es importante que lea todas las declaraciones de precaución y de peligro de este manual antes de seguir las instrucciones.

执行任何说明之前，请确保已阅读本书中的所有警告和危险声明。

Chapter 2. Safety information

This chapter contains the safety information that you need to be familiar with before servicing a computer.

General safety

Follow these rules to ensure general safety:

- Observe good housekeeping in the area of the machines during and after maintenance.
- When lifting any heavy object:
 1. Ensure you can stand safely without slipping.
 2. Distribute the weight of the object equally between your feet.
 3. Use a slow lifting force. Never move suddenly or twist when you attempt to lift.
 4. Lift by standing or by pushing up with your leg muscles; this action removes the strain from the muscles in your back.
Do not attempt to lift any objects that weigh more than 16 kg (35 lb) or objects that you think are too heavy for you.
- Do not perform any action that causes hazards to the customer, or that makes the equipment unsafe.
- Before you start the machine, ensure that other service representatives and the customer's personnel are not in a hazardous position.
- Place removed covers and other parts in a safe place, away from all personnel, while you are servicing the machine.
- Keep your tool case away from walk areas so that other people will not trip over it.
- Do not wear loose clothing that can be trapped in the moving parts of a machine. Ensure that your sleeves are fastened or rolled up above your elbows. If your hair is long, fasten it.
- Insert the ends of your necktie or scarf inside clothing or fasten it with a nonconductive clip, approximately 8 centimeters (3 inches) from the end.
- Do not wear jewelry, chains, metal-frame eyeglasses, or metal fasteners for your clothing.
Remember: Metal objects are good electrical conductors.
- Wear safety glasses when you are: hammering, drilling soldering, cutting wire, attaching springs, using solvents, or working in any other conditions that might be hazardous to your eyes.
- After service, reinstall all safety shields, guards, labels, and ground wires. Replace any safety device that is worn or defective.
- Reinstall all covers correctly before returning the machine to the customer.

Electrical safety

CAUTION:

Electrical current from power, telephone, and communication cables can be hazardous. To avoid personal injury or equipment damage, disconnect the attached power cords, telecommunication systems, networks, and modems before you open the computer covers, unless instructed otherwise in the installation and configuration procedures.

Observe the following rules when working on electrical equipment.

Important: Use only approved tools and test equipment. Some hand tools have handles covered with a soft material that does not insulate you when working with live electrical currents. Many customers have, near their equipment, rubber floor mats that contain small conductive fibers to decrease electrostatic discharges. Do not use this type of mat to protect yourself from electrical shock.

- Find the room emergency power-off (EPO) switch, disconnecting switch, or electrical outlet. If an electrical accident occurs, you can then operate the switch or unplug the power cord quickly.
- Do not work alone under hazardous conditions or near equipment that has hazardous voltages.
- Disconnect all power before:
 - Performing a mechanical inspection
 - Working near power supplies
 - Removing or installing Field Replaceable Units (FRUs)
- Before you start to work on the machine, unplug the power cord. If you cannot unplug it, ask the customer to power-off the wall box that supplies power to the machine and to lock the wall box in the off position.
- If you need to work on a machine that has exposed electrical circuits, observe the following precautions:
 - Ensure that another person, familiar with the power-off controls, is near you.
Remember: Another person must be there to switch off the power, if necessary.
 - Use only one hand when working with powered-on electrical equipment; keep the other hand in your pocket or behind your back.
Remember: There must be a complete circuit to cause electrical shock. By observing the above rule, you may prevent a current from passing through your body.
 - When using a tester, set the controls correctly and use the approved probe leads and accessories for that tester.
 - Stand on suitable rubber mats (obtained locally, if necessary) to insulate you from grounds such as metal floor strips and machine frames.

Observe the special safety precautions when you work with very high voltages; these instructions are in the safety sections of maintenance information. Use extreme care when measuring high voltages.

- Regularly inspect and maintain your electrical hand tools for safe operational condition.
- Do not use worn or broken tools and testers.
- *Never assume* that power has been disconnected from a circuit. First, *check* that it has been powered-off.
- Always look carefully for possible hazards in your work area. Examples of these hazards are moist floors, nongrounded power extension cables, power surges, and missing safety grounds.
- Do not touch live electrical circuits with the reflective surface of a plastic dental mirror. The surface is conductive; such touching can cause personal injury and machine damage.
- Do not service the following parts with the power on when they are removed from their normal operating places in a machine:
 - Power supply units
 - Pumps
 - Blowers and fans
 - Motor generatorsand similar units. (This practice ensures correct grounding of the units.)
- If an electrical accident occurs:
 - Use caution; do not become a victim yourself.
 - Switch off power.
 - Send another person to get medical aid.

Safety inspection guide

The intent of this inspection guide is to assist you in identifying potentially unsafe conditions on these products. Each machine, as it was designed and built, had required safety items installed to protect users and service personnel from injury. This guide addresses only those items. However, good judgment should be used to identify potential safety hazards due to attachment of features or options not covered by this inspection guide.

If any unsafe conditions are present, you must determine how serious the apparent hazard could be and whether you can continue without first correcting the problem.

Consider these conditions and the safety hazards they present:

- Electrical hazards, especially primary power (primary voltage on the frame can cause serious or fatal electrical shock).
- Explosive hazards, such as a damaged CRT face or bulging capacitor
- Mechanical hazards, such as loose or missing hardware

The guide consists of a series of steps presented in a checklist. Begin the checks with the power off, and the power cord disconnected.

Checklist:

1. Check exterior covers for damage (loose, broken, or sharp edges).
2. Power-off the computer. Disconnect the power cord.
3. Check the power cord for:
 - a. A third-wire ground connector in good condition. Use a meter to measure third-wire ground continuity for 0.1 ohm or less between the external ground pin and frame ground.
 - b. The power cord should be the appropriate type as specified in the parts listings.
 - c. Insulation must not be frayed or worn.
4. Remove the cover.
5. Check for any obvious alterations. Use good judgment as to the safety of any alterations.
6. Check inside the unit for any obvious unsafe conditions, such as metal filings, contamination, water or other liquids, or signs of fire or smoke damage.
7. Check for worn, frayed, or pinched cables.
8. Check that the power-supply cover fasteners (screws or rivets) have not been removed or tampered with.

Handling electrostatic discharge-sensitive devices

Any computer part containing transistors or integrated circuits (ICs) should be considered sensitive to electrostatic discharge (ESD). ESD damage can occur when there is a difference in charge between objects. Protect against ESD damage by equalizing the charge so that the machine, the part, the work mat, and the person handling the part are all at the same charge.

Notes:

1. Use product-specific ESD procedures when they exceed the requirements noted here.
2. Make sure that the ESD protective devices you use have been certified (ISO 9000) as fully effective.

When handling ESD-sensitive parts:

- Keep the parts in protective packages until they are inserted into the product.
- Avoid contact with other people while handling the part.

- Wear a grounded wrist strap against your skin to eliminate static on your body.
- Prevent the part from touching your clothing. Most clothing is insulative and retains a charge even when you are wearing a wrist strap.
- Use the black side of a grounded work mat to provide a static-free work surface. The mat is especially useful when handling ESD-sensitive devices.
- Select a grounding system, such as those listed below, to provide protection that meets the specific service requirement.

Note: The use of a grounding system is desirable but not required to protect against ESD damage.

- Attach the ESD ground clip to any frame ground, ground braid, or green-wire ground.
- Use an ESD common ground or reference point when working on a double-insulated or battery-operated system. You can use coax or connector-outside shells on these systems.
- Use the round ground-prong of the ac plug on ac-operated computers.

Grounding requirements

Electrical grounding of the computer is required for operator safety and correct system function. Proper grounding of the electrical outlet can be verified by a certified electrician.

Safety notices

The caution and danger safety notices in this section are provided in the the language of English.



DANGER

Electrical current from power, telephone and communication cables is hazardous.

To avoid a shock hazard:

- **Do not connect or disconnect any cables or perform installation, maintenance, or reconfiguration of this product during an electrical storm.**
- **Connect all power cords to a properly wired and grounded electrical outlet.**
- **Connect to properly wired outlets any equipment that will be attached to this product.**
- **When possible, use one hand only to connect or disconnect signal cables.**
- **Never turn on any equipment when there is evidence of fire, water, or structural damage.**
- **Disconnect the attached power cords, telecommunications systems, networks, and modems before you open the device covers, unless instructed otherwise in the installation and configuration procedures.**
- **Connect and disconnect cables as described in the following table when installing, moving, or opening covers on this product or attached devices.**

To Connect	To Disconnect
<ol style="list-style-type: none"> 1. Turn everything OFF. 2. First, attach all cables to devices. 3. Attach signal cables to connectors. 4. Attach power cords to outlet. 5. Turn device ON. 	<ol style="list-style-type: none"> 1. Turn everything OFF. 2. First, remove power cords from outlet. 3. Remove signal cables from connectors. 4. Remove all cables from devices.



CAUTION:

When replacing the lithium battery, use only Part Number 45C1566 or an equivalent type battery recommended by the manufacturer. If your system has a module containing a lithium battery, replace it only with the same module type made by the same manufacturer. The battery contains lithium and can explode if not properly used, handled, or disposed of.

Do not:

- Throw or immerse into water
- Heat to more than 100°C (212°F)
- Repair or disassemble

Dispose of the battery as required by local ordinances or regulations.



CAUTION:

When laser products (such as CD-ROMs, DVD-ROM drives, fiber optic devices, or transmitters) are installed, note the following:

- Do not remove the covers. Removing the covers of the laser product could result in exposure to hazardous laser radiation. There are no serviceable parts inside the device.
- Use of controls or adjustments or performance of procedures other than those specified herein might result in hazardous radiation exposure.





 **DANGER**

Some laser products contain an embedded Class 3A or Class 3B laser diode. Note the following:

Laser radiation when open. Do not stare into the beam, do not view directly with optical instruments, and avoid direct exposure to the beam.



		
≥18 kg(37 lbs)	≥32 kg(70.5 lbs)	≥55 kg(121.2 lbs)

CAUTION:
Use safe practices when lifting.



CAUTION:
The power control button on the device and the power switch on the power supply do not turn off the electrical current supplied to the device. The device also might have more than one power cord. To remove all electrical current from the device, ensure that all power cords are disconnected from the power source.

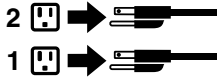

CAUTION:
Do not place any object weighing more than 82 kg (180 lbs.) on top of rack-mounted devices.



Chapter 3. General information

This chapter provides general information that applies to all machine types supported by this publication.

Specifications

This section lists the physical specifications for your computer.

This section lists the physical specifications for your computer.

Type Lenovo C220/C225/C320/C325

This section lists the physical specifications.

Environment

Air temperature:

Operating: 10° to 35°C

Transit: -20° to 55°C

Humidity:

Operating: 35% to 80%

Transit: 20% to 93% (40°C)

Altitude: 86KPa to 106KPa

Electrical input:

Input voltage: 90V-264V(AC)

Input frequency: 47Hz-63Hz

Chapter 4. General Checkout

Attention: The drives in the computer you are servicing might have been rearranged or the drive startup sequence changed. Be extremely careful during write operations such as copying, saving, or formatting. Data or programs can be overwritten if you select an incorrect drive.

General error messages appear if a problem or conflict is found by an application program, the operating system, or both. For an explanation of these messages, refer to the information supplied with that software package.

Use the following procedure to help determine the cause of the problem:

1. Power-off the computer and all external devices.
2. Check all cables and power cords.
3. Set all display controls to the middle position.
4. Power-on all external devices.
5. Power-on the computer.
 - Look for displayed error codes
 - Look for readable instructions or a main menu on the display.

If you did not receive the correct response, proceed to step 6.

If you do receive the correct response, proceed to step 7.

6. Look at the following conditions and follow the instructions:
 - If the computer displays a POST error, go to “POST error codes”.
 - If the computer hangs and no error is displayed, continue at step 7.
7. If you cannot continue, replace the last device tested.

Problem determination tips

Due to the variety of hardware and software combinations that can be encountered, use the following information to assist you in problem determination. If possible, have this information available when requesting assistance from Service Support and Engineering functions.

- Machine type and model
- Processor or hard disk upgrades
- Failure symptom

Do diagnostics indicate a failure?

What, when, where, single, or multiple systems?

Is the failure repeatable?

Has this configuration ever worked?

If it has been working, what changes were made prior to it failing?

Is this the original reported failure?

- Diagnostics version

Type and version level

- Hardware configuration
 - Print (print screen) configuration currently in use
 - BIOS level
- Operating system software
 - Type and version level

Notes: To eliminate confusion, identical systems are considered identical only if they:

1. Are the exact machine type and models
2. Have the same BIOS level
3. Have the same adapters/attachments in the same locations
4. Have the same address jumpers/terminators/cabling
5. Have the same software versions and levels
6. Have the same configuration options set in the system
7. Have the same setup for the operation system control files

Comparing the configuration and software set-up between “working and non-working” systems will often lead to problem resolution.

Chapter 5. Using the Setup Utility

The Setup Utility program is used to view and change the configuration settings of your computer, regardless of which operating system you are using. However, the operating-system settings might override any similar settings in the Setup Utility program.

Starting the Setup Utility program

To start the Setup Utility program, do the following:

1. If your computer is already on when you start this procedure, shut down the operating system and turn off the computer.
2. Press and hold the F1 key then turn on the computer. When you hear multiple beeps, release the F1 key.

Notes:

1. If you are using a USB keyboard and the Setup Utility program does not display using this method, repeatedly press and release the F1 key rather than leaving it pressed when turning on the computer.
2. If a Power-On Password or an administrator password has been set, the Setup Utility program menu is not displayed until you type your password. For more information, see “Using passwords.”

Viewing and changing settings

The Setup Utility program menu lists items that identify system configuration topics. To view or change settings, see “Starting the Setup Utility program.”

When working with the Setup Utility program menu, you must use the keyboard. The keys used to perform various tasks are displayed on the right side of each screen.

Using passwords

By using the Setup Utility program, you can set passwords to prevent unauthorized persons from gaining access to your computer and data. See “Starting the Setup Utility program.” The following types of passwords are available:

- Administrator Password
- Power-On Password

You do not have to set any passwords to use your computer. However, if you decide to set any passwords, read the following sections.

Password considerations

A password can be any combination of up to 64 characters (a-z and 0-9) and symbols. For security reasons, it is a good idea to use a strong password that cannot be easily compromised. We suggest the passwords should adhere to the following rules:

- Must have at least seven characters in length
- Contain at least one alphabetic character and one numeric character
- Setup Utility program and hard disk drive passwords are not case sensitive
- Not be your name or your user name

- Not be a common word or a common name
- Be significantly different from your previous password

Administrator password

When a Administrator Password is set, it deters unauthorized persons from changing configuration settings. If you are responsible for maintaining the settings of several computers, you might want to set a Administrator Password.

After you set a Administrator Password, a password prompt is displayed each time you try to access the Setup Utility program.

If both the Administrator and Power-On Password are set, you can type either password. However, to change any configuration settings, you must use your Administrator password.

Setting, changing, and deleting a Administrator password

To set, change, or delete a password, do the following:

Note: A password can be any combination of up to 64 characters (a-z, and 0-9). For more information, see “Password considerations” on page 13.

1. Start the Setup Utility program (see “Starting the Setup Utility program” on page 13).
2. From Security menu, select Set Administrator Password and press Enter.
3. The password dialog box will be displayed. Type the new password, and press Enter.
4. when prompted to confirm the password, type the password again. If you type the password correctly, the password will be installed.

To delete a previously set Administrator password, do the following :

Note: When prompted for a password, you must type your Administrator password.

1. From Security menu, select Set Administrator Password and press Enter.
2. The password dialog box will be displayed. Enter Current Password and press Enter. Press Enter in New Password and confirm New Password dialog. A setup notice will display that changes have been saved.
3. Select **Exit**.
4. Select **Save changes and Exit**.

Power-On Password

When a Power-On Password is set, you cannot start the Setup Utility program until a valid password is typed from the keyboard.

Setting, changing, and deleting a Power-On Password

To set, change, or delete a Power-On Password, do the following:

Note: A password can be any combination of up to 64 characters(a-z, and 0-9).

1. Start the Setup Utility program (See ”Starting the Setup Utility program”.)
2. From the Security menu, select Set Power-On Password and press Enter.
3. The password dialog box will be displayed. Type the new password, and press Enter.
4. when prompted to confirm the password, type the password again. If you type the password correctly, the password will be installed.

To delete a previously set Power-On Password, do the following :

1. From the Security menu, select **Set Power-On Password** and press **Enter**.
2. The password dialog box will be displayed. Enter Current Password and press Enter. Press Enter in New Password and confirm New Password dialog. A setup notice will display that changes have been saved.
3. Select **Exit**.
4. Select **Save changes and Exit**.

Using Device

Device is used to enable or disable user access to the following device:	
USB Setup	When this feature is set to Disable, the device of USB Setup is Disabled and will not be displayed in the system configuration.

To set Device, do the following:

1. Start the Setup Utility program (see “Starting the Setup Utility program” on page 13).
2. From the Setup Utility program menu, select **Devices**.
3. Select **USB Setup**.
4. Select **Disabled** or **Enabled** and press Enter.
5. Return to the Setup Utility program menu and press F10 to save configuration changes and exit setup.

Note: If you do not want to save the settings, select **Exit and select Discard changes and Exit**. You can set others such as **Audio Setup and Network Setup**. See the information displayed on the right side of the screen.

Selecting a startup device

If your computer does not start up (boot) from a device such as the CD-ROM, diskette, or hard disk as expected, use one of the following procedures to select a startup device.

Selecting a temporary startup device

Use this procedure to startup from any boot device.

Note: Not all CDs, hard disks, and diskettes are bootable.

1. Turn off your computer.
2. Press and hold the F12 key then turn on the computer. When the Startup Device Menu appears, release the F12 key.

Note: If you are using a USB keyboard and the Startup Device Menu does not display using this method, repeatedly press and release the F12 key rather than leaving it pressed when turning on the computer.

3. Select the desired startup device from the Startup Device Menu and press Enter to begin.

Note: Selecting a startup device from the Startup Device menu does not permanently change the startup sequence.

Selecting or changing the startup device sequence

To view or permanently change the configured startup device sequence, do the following:

1. Start the Setup Utility program (see “Starting the Setup Utility program” on page 13).

2. Select **Start Up**.
3. Select Quick Boot Mode, Numlock, Option Keys Display, to set these devices.
4. Select Disabled or Enabled and press Enter.
5. Press ESC to return to Exit and select Save changes and Exit.

If you have changed these settings and want to return to the default settings, select **Load Optimal Defaults** on the Setup Utility menu.

Exiting from the Setup Utility program

When you finish viewing or changing settings, press **Esc** to return to the Setup Utility program menu (you might have to press **Esc** several times). If you want to save the new settings, select **Save changes and Exit** before you exit. Otherwise, your changes will not be saved.

Chapter 6. Symptom-to-FRU Index

The Symptom-to-FRU index lists error symptoms and possible causes. The most likely cause is listed first. Always begin with Chapter 4, “General Checkout,” on page 11. This index can also be used to help you decide which FRUs to have available when servicing a computer. If you are unable to correct the problem using this index, go to “Undetermined problems” on page 18.

Notes:

- If you have both an error message and an incorrect audio response diagnose the error message first.
- If you cannot run the diagnostic tests or you get a diagnostic error code when running a test but did receive a POST error message diagnose the POST error message first.
- If you did not receive any error message look for a description of your error symptoms in the first part of this index.

Hard disk drive boot error

A hard disk drive boot error (error codes 1962 and I999030X) can have the following causes.

Error	FRU/Action
The start-up drive is not in the boot sequence in configuration.	Check the configuration and ensure the start-up drive is in the boot sequence.
No operating system installed on the boot drive.	Install an operating system on the boot drive.
The boot sector on the start-up drive is corrupted.	The drive must be formatted do the following: <ol style="list-style-type: none">1. Attempt to back-up the data on the failing hard disk drive.2. Using the operating systems programs format the hard disk drive.
The drive is defective.	Replace the hard disk drive.

Power Supply Problems

If you suspect a power problem, use the following procedures.

Check/Verify	FRU/Action
Check the following for proper installation. <ul style="list-style-type: none">• Power Cord• On/Off Switch connector• On/Off Switch Power Supply connector• System Board Power Supply connectors• Microprocessor(s) connection	Reseat connectors
Check the power cord for continuity.	Power Cord
Check the power-on switch for continuity.	Power-on Switch

POST error codes

Each time you power-on the system, it performs a series of tests that check the operation of the system and some options. This series of tests is called the *Power-On Self-Test*, or *POST*. POST does the following operations.

- Checks some basic system-board operations
- Checks the memory operation
- Starts the video operation
- Verifies that the boot drive is working

If the POST detects a problem, an error message appears on the screen. A single problem can cause several error messages to appear. When you correct the cause of the first error message, the other error messages probably will not appear on the screen the next time you turn on the system.

POST Error Message	Description/Action
CMOS Date/Time Not Set	The CMOS Date and/or Time are invalid. This error can be resolved by readjusting the system time in AMI BIOS Setup.
CMOS Battery Low	The CMOS battery is no longer functional. Replace the battery.
CMOS Checksum Bad	Checksum of CMOS is incorrect. The computer loads the default configuration settings. This error might indicate that CMOS has become corrupt due to a weak CMOS battery.
Primary Master Hard Disk Error	The IDE/ATAPI device configured as Primary Master/Primary Slave/ Secondary Master/Secondary Slave could not be found or initialized. Make sure the hard drive is correctly installed.
Primary Slave Hard Disk Error	
Secondary Master Hard Disk Error	
Secondary Slave Hard Disk Error	
Keyboard error	Cannot initialize the keyboard. Make sure the keyboard is properly connected to the computer and that no keys are held pressed during POST. To purposely configure the computer without a keyboard, set keyboardless operation in Setup to Enable. The BIOS then ignores the missing keyboard during POST.
System Halted	The system has been halted. A reset or power cycle is required to reboot the machine. This message appears after a fatal error has been detected.
Reboot and Select proper Boot device or Insert Boot Media in selected Boot device	The BIOS was unable to find a suitable boot device. Make sure the boot drive is properly connected to the computer. Make sure you have bootable media.

Undetermined problems

If this computer has a parallel ATA hard disk drive, make sure that the hard disk drive is jumpered as a master and the optical drive is jumpered as a slave.

1. Power-off the computer.
2. Remove or disconnect the following components (if installed) one at a time.
 - a. External devices (modem, printer, or mouse)
 - b. Any adapters

- c. Memory modules
 - d. Extended video memory
 - e. External Cache
 - f. External Cache RAM
 - g. Hard disk drive
 - h. Diskette drive
3. Power-on the computer to re-test the system.
 4. Repeat steps 1 through 3 until you find the failing device or adapter.

If all devices and adapters have been removed, and the problem continues, replace the system board.

Chapter 7. Replacing hardware

Attention: Do not remove the computer cover or attempt any repair before reading the “Important safety information” in the Safety and Warranty Guide that was included with your computer or in the Hardware Maintenance Manual (HMM) for the computer. To obtain copies of the Safety and Warranty Guide or HMM, go to the Support Web site at: <http://consumersupport.lenovo.com>.

Note: Use only parts provided by Lenovo.

General information

Pre-disassembly instructions

Before proceeding with the disassembly procedure, make sure that you do the following:

1. Turn off the power to the system and all peripherals.
2. Unplug all power and signal cables from the computer.
3. Place the system on a flat, stable surface.

Hardware components

The following illustration shows the components that make up your computer.

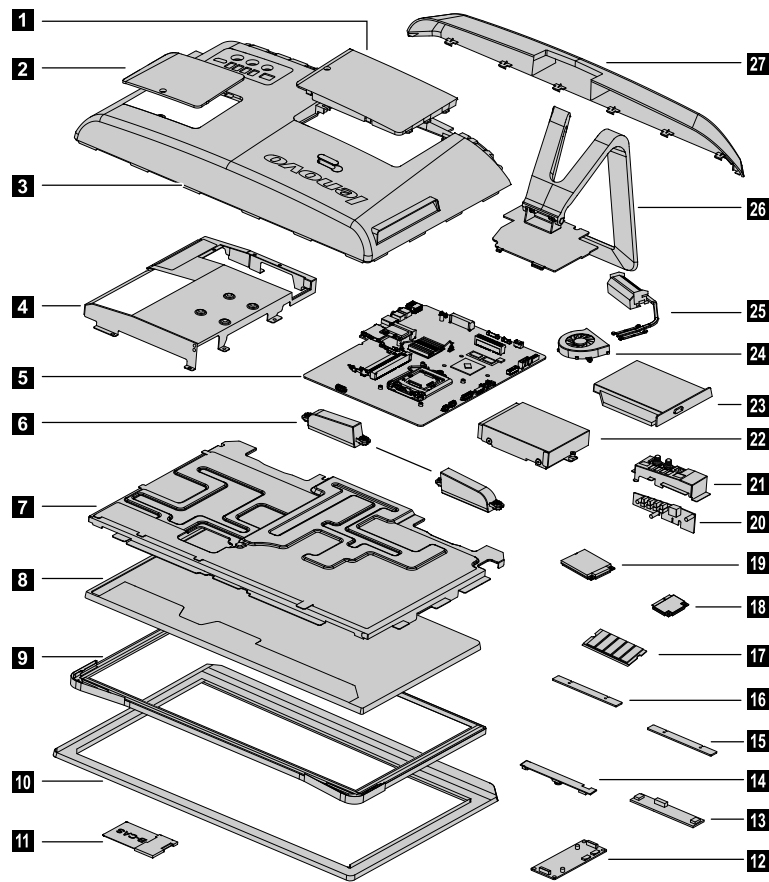

1. Hard disk drive cover	15. Function button board
2. Memory cover	16. Power and front LED board
3. Rear cover	17. RAM
4. EMI cover	18. WLAN card
5. Motherboard	19. TV tuner card
6. Speakers	20. Rear I/O Board
7. Chassis	21. Rear I/O module
8. LED panel	22. Hard disk drive
9. Touch camera module and glass	23. Optical disk drive
10. Front bezel	24. System fan
11. B-CAS card	25. Heatsink module
12. Converter	26. Computer stand
13. Touch control board	27. Speaker Cover
14. Camera	

Identifying parts on the motherboard

The motherboard (sometimes called the planar or system board) is the main circuit board in your computer. It provides basic computing functions and supports a variety of devices that are factory-installed or that you can install later.

The following illustration shows the locations of parts on the motherboard for model C220.

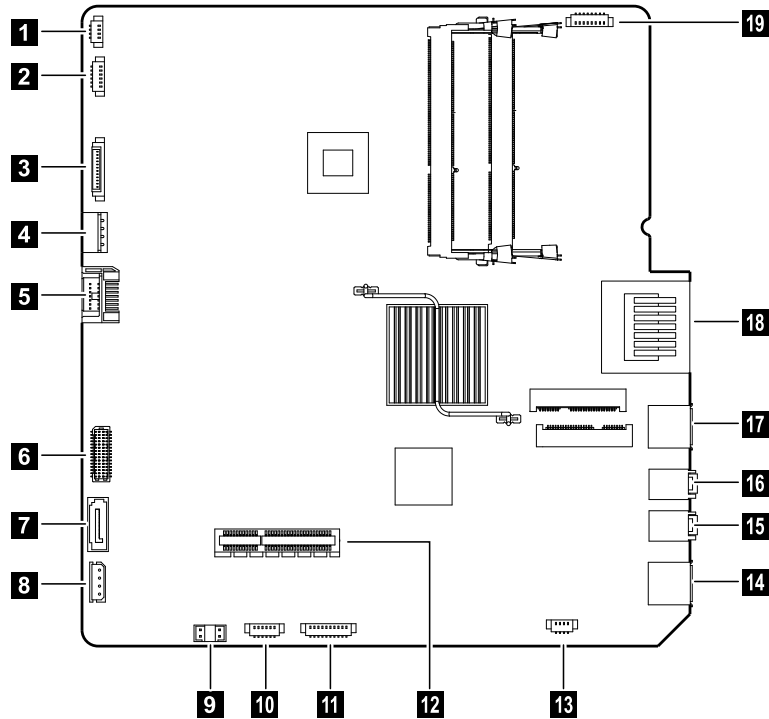

1. System fan	11. Power Board
2. Touch Screen	12. I/O Board
3. Converter	13. Speaker
4. ODD Power	14. USB connector
5. ODD SATA	15. Microphone connector
6. LVDS	16. Headphone connector
7. HDD SATA	17. USB connector
8. HDD Power	18. Card reader connector
9. DC Jack	19. Camera
10. Function Board	

The following illustration shows the locations of parts on the motherboard for models C225 and C325.

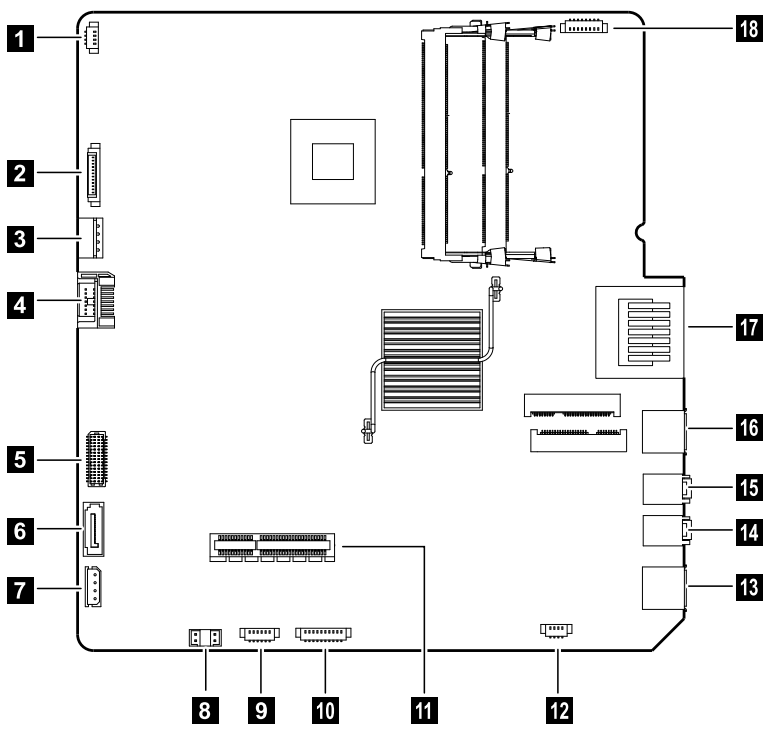

1. System fan	10. Power Board
2. Converter	11. I/O Board
3. ODD Power	12. Speaker
4. ODD SATA	13. USB connector
5. LVDS	14. Microphone connector
6. HDD SATA	15. Headphone connector
7. HDD Power	16. USB connector
8. DC Jack	17. Card reader connector
9. Function Board	18. Camera

The following illustration shows the locations of parts on the motherboard for model C320.

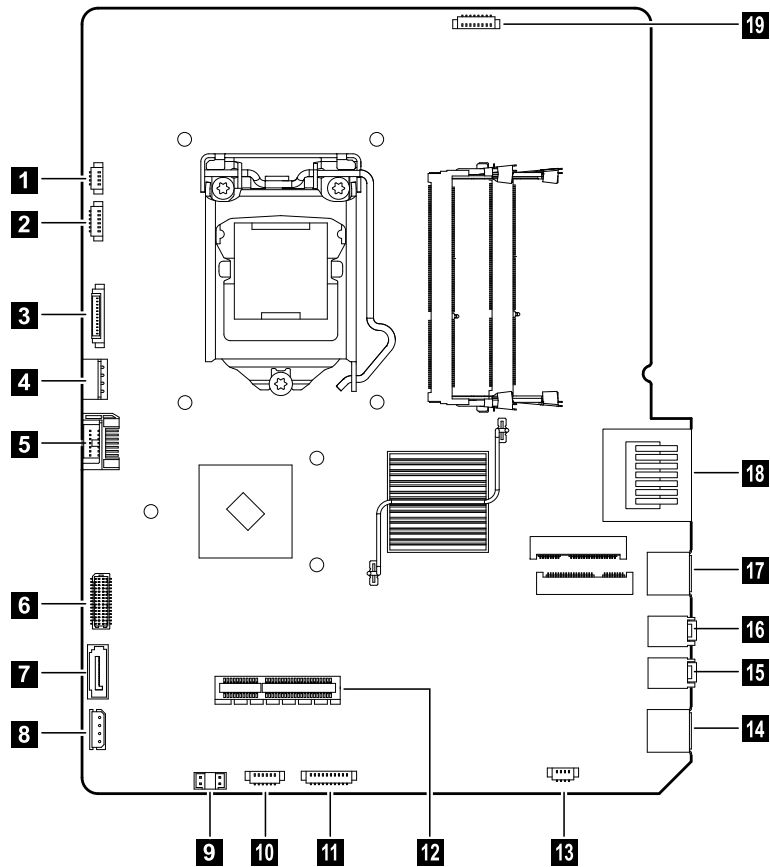

1. System fan	11. Power Board
2. Touch Screen	12. I/O Board
3. Converter	13. Speaker
4. ODD Power	14. USB connector
5. ODD SATA	15. Microphone connector
6. LVDS	16. Headphone connector
7. HDD SATA	17. USB connector
8. HDD Power	18. Card reader connector
9. AC in	19. Camera
10. Function Board	

Replacing a memory module

Attention: Turn off the computer and wait 3 to 5 minutes to let it cool down before removing the cover.

Note: It may be helpful to place the computer face-down on a soft flat surface for this procedure. Lenovo recommends that you use a blanket, towel, or other soft cloth to protect the touch screen from scratches or other damage.

To replace a memory module

- Step 1. Remove any media (disks, CDs, or memory cards) from the drives, shut down the operating system, and turn off the computer and all attached devices.
- Step 2. Unplug all power cords from electrical outlets.
- Step 3. Disconnect all cables attached to the computer. This includes power cords, input/output (I/O) cables, and any other cables that are connected to the computer. Refer to “Left and right view” and “Rear view” for help with locating the various connectors.
- Step 4. Remove the memory cover as shown. **1 2**

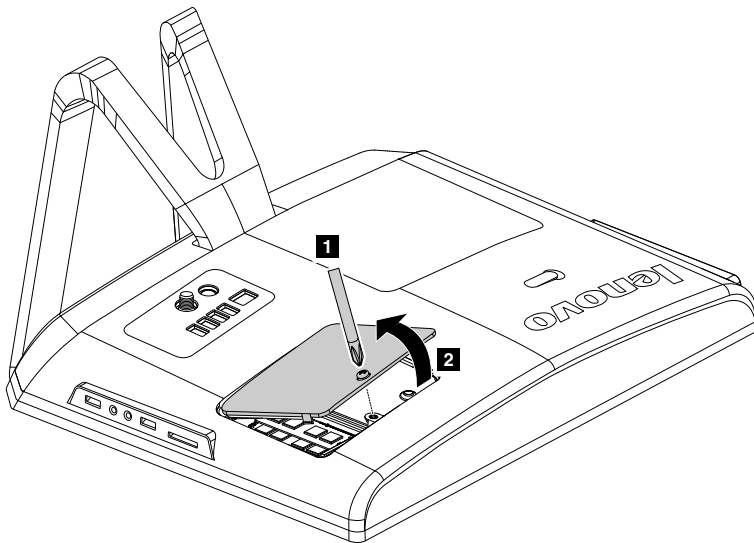

- Step 5. Push out the latches on both sides of the memory socket to release the memory module and gently pull the memory module upward to remove it from its socket. All of the memory modules can be removed using the same procedure. **3 4**

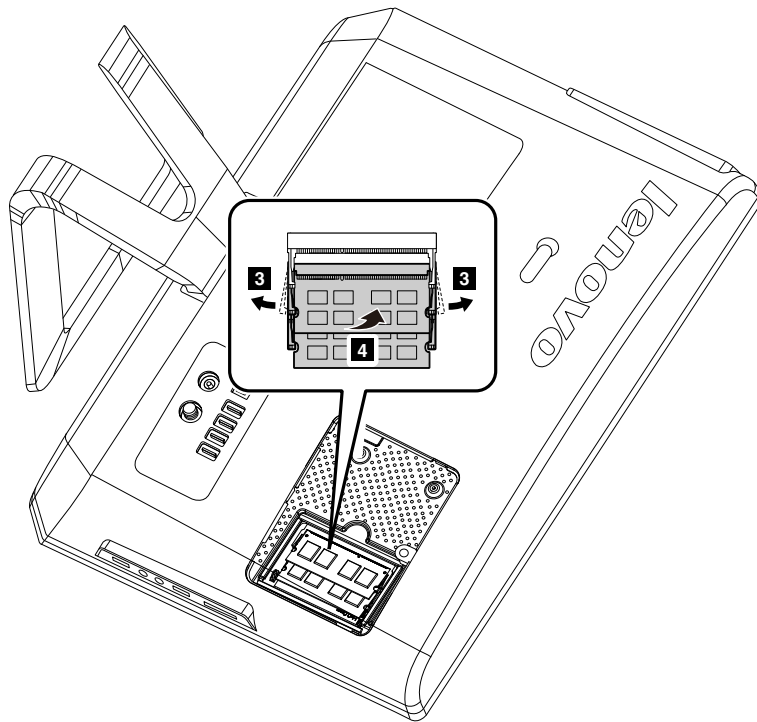

- Step 6. Align the new memory module with the memory socket, then insert it and push down on the top edge. Make sure the latches lock the memory module in place.
- Step 7. Align then slide back the memory cover.
- Step 8. Reattach the memory cover and secure it with the screw.

Replacing the optical drive

Attention: Turn off the computer and wait 3 to 5 minutes to let it cool down before removing the cover.

Note: It may be helpful to place the computer face-down on a soft flat surface for this procedure. Lenovo recommends that you use a blanket, towel, or other soft cloth to protect the touch screen from scratches or other damage.

To replace the optical drive

- Step 1. Remove any media (disks, CDs, or memory cards) from the drives, shut down the operating system, and turn off the computer and all attached devices.
- Step 2. Unplug all power cords from electrical outlets.
- Step 3. Disconnect all cables attached to the computer. This includes power cords, input/output (I/O) cables, and any other cables that are connected to the computer. Refer to “Left and right view” and “Rear view” for help with locating the various connectors.
- Step 4. Remove the rubber cap that protects the screw. **1 2**
- Step 5. Remove the screw that secures the optical drive to the chassis. **3**
- Step 6. Push the optical drive so that it slides out of the drive bay. **4**

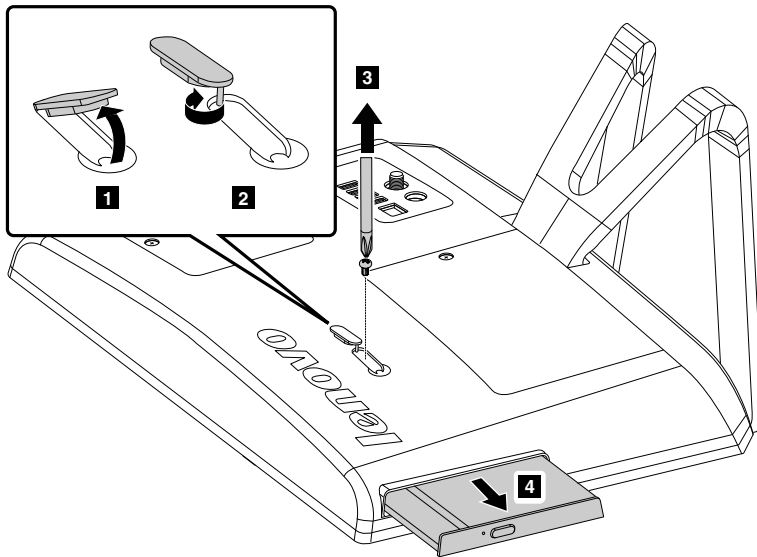

Step 7. Push a small metal stick (e.g.a paper clip) into the small hole on the optical drive cover so that the drive springs out as shown.

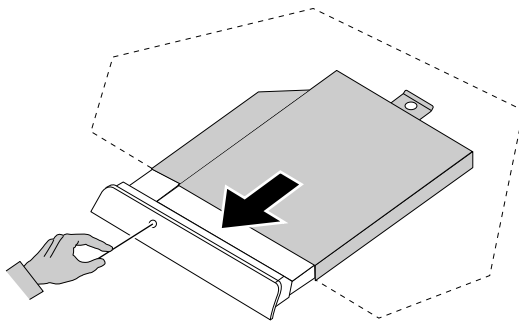

Step 8. Remove the 2 screws that secure the optical drive to the metal bracket. **1**

Step 9. Use a small flat head screwdriver to press and push out the pins that secure the cover to the disk. **2 3**

Step 10. Separate the cover from the defective optical drive.

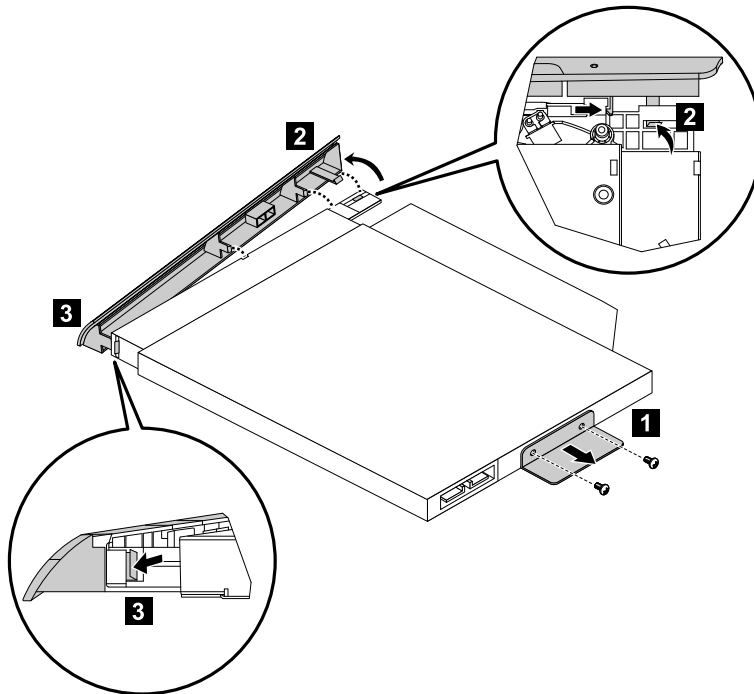

Step 11. Install the new optical drive as follows:

- a. Align the new optical drive with the cover, and then push the cover back into position.
- b. Screw the metal bracket onto the new optical drive.
- c. Slide the new optical drive into the drive bay.

Step 12. Screw the new optical drive onto the chassis.

Replacing the hard disk drive

Attention: Turn off the computer and wait 3 to 5 minutes to let it cool down before removing the cover.

Note: It may be helpful to place the computer face-down on a soft flat surface for this procedure. Lenovo recommends that you use a blanket, towel, or other soft cloth to protect the touch screen from scratches or other damage.

To replace the hard disk drive

- Step 1. Remove any media (disks, CDs, or memory cards) from the drives, shut down the operating system, and turn off the computer and all attached devices.
- Step 2. Unplug all power cords from electrical outlets.
- Step 3. Disconnect all cables attached to the computer. This includes power cords, input/output (I/O) cables, and any other cables that are connected to the computer. Refer to “Left and right view” and “Rear view” for help with locating the various connectors.
- Step 4. Remove the hard disk drive cover as shown. **1 2**

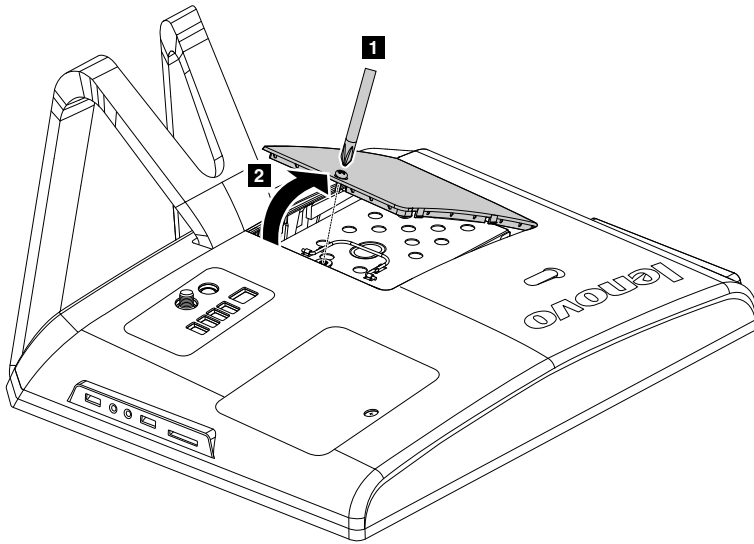

Step 5. Remove the screw that secures the hard disk drive bay to the chassis. **3**

Step 6. Spring up the handle on the hard disk drive bay, then slide and lift the hard disk drive bay out of the chassis as shown. **4**

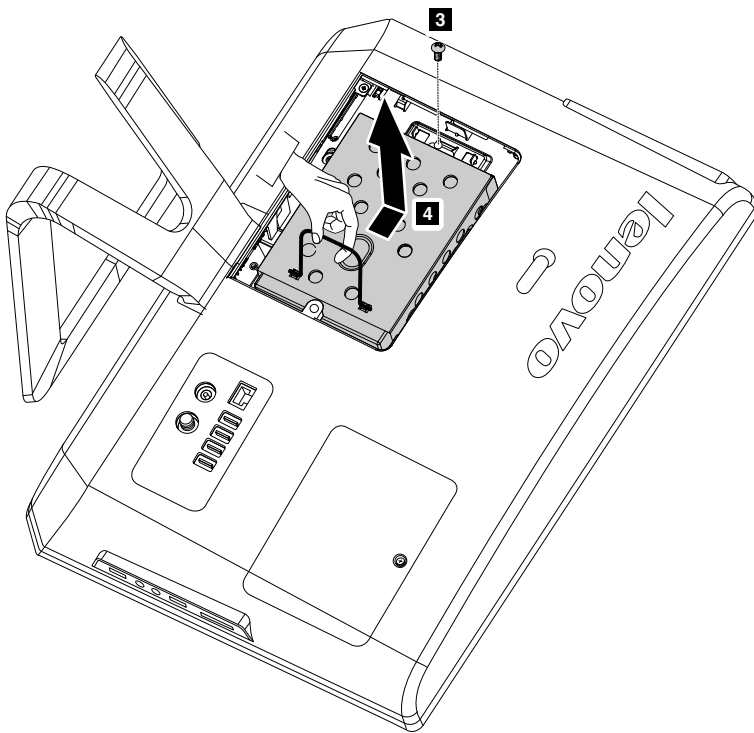

Step 7. Remove the 4 screws that secure the hard disk drive to the disk bay and slide the defective hard disk drive out of the bay.

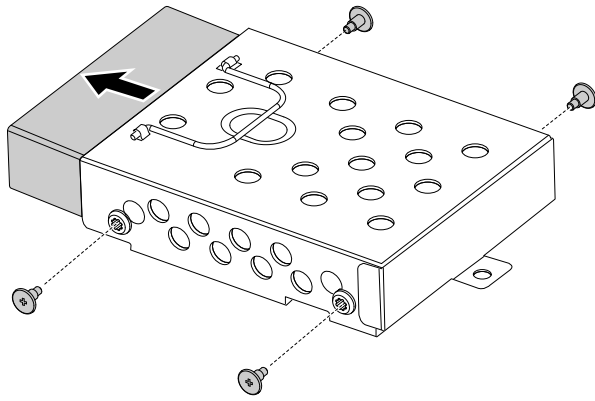

- Step 8. Install the new hard disk drive as follows:
- Slide the new hard disk drive into the drive bay.
 - Screw the 4 screws back onto the drive bay.
- Step 9. Slide the hard disk drive bay back into position.
- Step 10. Secure the hard disk drive bay to the chassis with the screw.
- Step 11. Reattach the hard disk drive cover and secure it with the screw.

Replacing the keyboard and mouse

Attention: Turn off the computer and wait 3 to 5 minutes to let it cool down before removing the cover.

Note: It may be helpful to place the computer face-down on a soft flat surface for this procedure. Lenovo recommends that you use a blanket, towel, or other soft cloth to protect the touch screen from scratches or other damage.

To replace the keyboard and mouse

- Step 1. Remove any media (disks, CDs, or memory cards) from the drives, shut down the operating system, and turn off the computer and all attached devices.
- Step 2. Unplug all power cords from electrical outlets.
- Step 3. Disconnect all cables attached to the computer. This includes power cords, input/output (I/O) cables, and any other cables that are connected to the computer. Refer to “Left and right view” and “Rear view” for help with locating the various connectors.

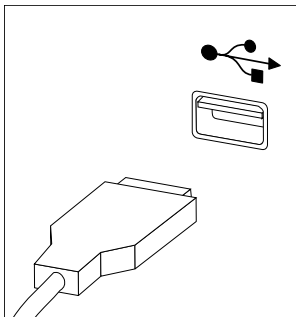

Note: Your keyboard will be connected to a USB connector on one or other side or at the rear of the computer.

- Step 4. Disconnect the defective keyboard cable from the computer and connect the new keyboard cable to the same connector.

Step 5. The mouse can be replaced using the same method.

Replacing the power cord

Attention: Turn off the computer and wait 3 to 5 minutes to let it cool down before removing the cover.

Note: It may be helpful to place the computer face-down on a soft flat surface for this procedure. Lenovo recommends that you use a blanket, towel, or other soft cloth to protect the touch screen from scratches or other damage.

To replace the power cord

- Step 1. Remove any media (disks, CDs, or memory cards) from the drives, shut down the operating system, and turn off the computer and all attached devices.
- Step 2. Unplug all power cords from electrical outlets.
- Step 3. Disconnect all cables attached to the computer. This includes power cords, input/output (I/O) cables, and any other cables that are connected to the computer. Refer to “Left and right view” and “Rear view” for help with locating the various connectors.
- Step 4. Disconnect the defective power cord from the computer and connect the new power cord to the same connector.

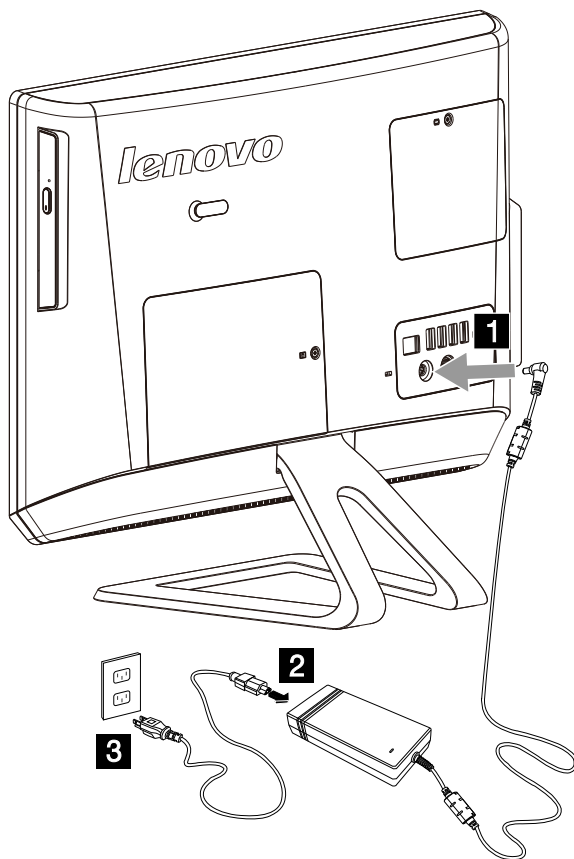

Removing the speaker cover

Note: Turn off the computer and wait 3 to 5 minutes to let the computer cool before removing the speaker cover.

To replace the speaker cover:

Note: For this procedure, it helps to place the computer face-down on a soft flat surface. Lenovo recommends that you use a blanket, towel, or other soft cloth to protect the screen surface from scratches or other damage.

Step 1. Remove the hard disk drive cover. Refer to “Removing the hard disk drive”.

Step 2. Remove the screw that secures the speaker cover to the computer cover.

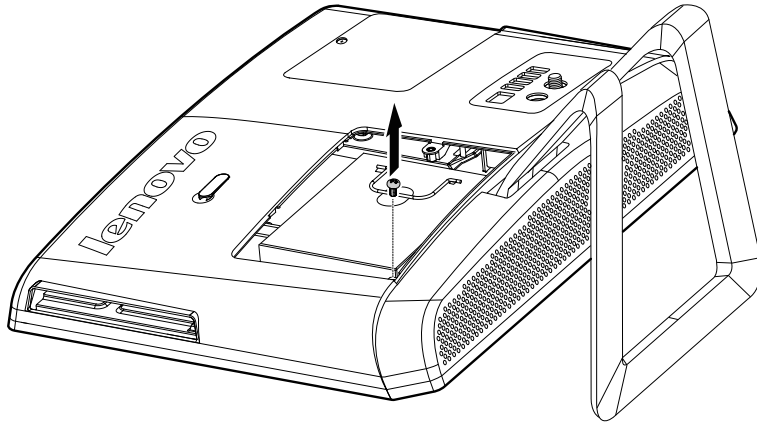

Step 3. Slide the hard disk drive cover out as shown.

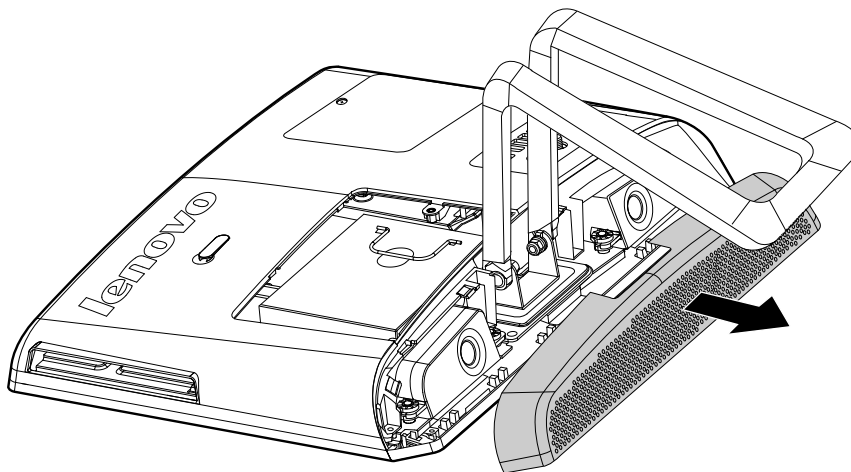
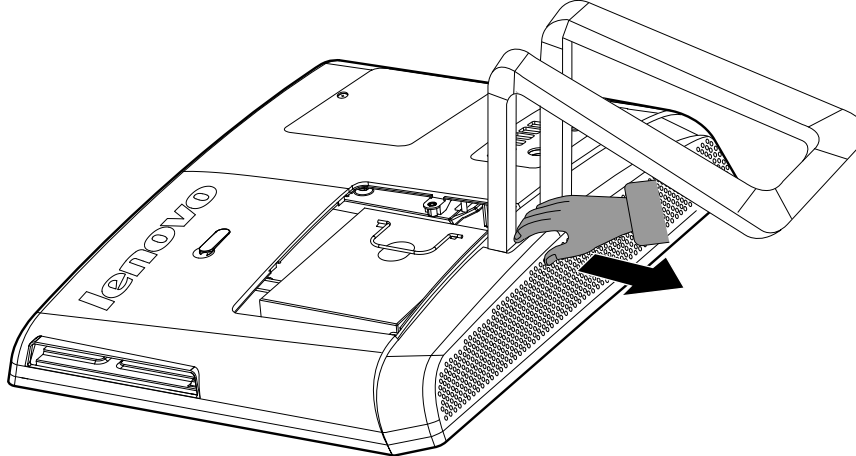

Removing the computer cover

Note: Turn off the computer and wait 3 to 5 minutes to let the computer cool down before removing the computer cover.

Note: It may be helpful to place the computer face-down on a soft flat surface for this procedure. Lenovo recommends that you use a blanket, towel, or other soft cloth to protect the computer screen from scratches or other damage.

To remove the computer cover

- Step 1. Remove any media (disks, CDs, or memory cards) from the drives, shut down the operating system, and turn off the computer and all attached devices.
- Step 2. Unplug all power cords from electrical outlets.
- Step 3. Disconnect all cables attached to the computer. This includes power cords, input/output (I/O) cables, and any other cables that are connected to the computer. Refer to “Left and right view” and “Rear view” for help with locating the various connectors.
- Step 4. Remove the optical drive. Refer to “Replacing the optical drive”.
- Step 5. Remove the hard disk drive cover. Refer to “Replacing the hard disk drive”.
- Step 6. Remove the speaker cover. Refer to “Removing the speaker cover”.
- Step 7. Remove the 4 screws that secure the computer cover to the chassis.

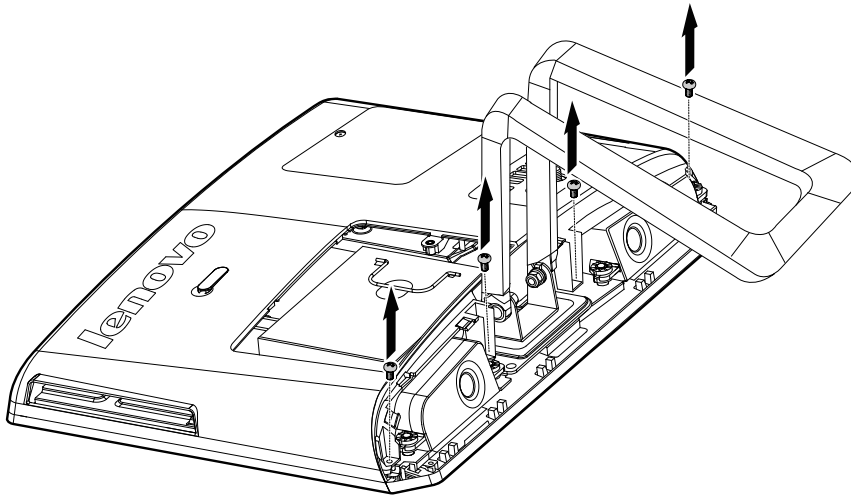

- Step 8. Lift up the computer cover as shown.

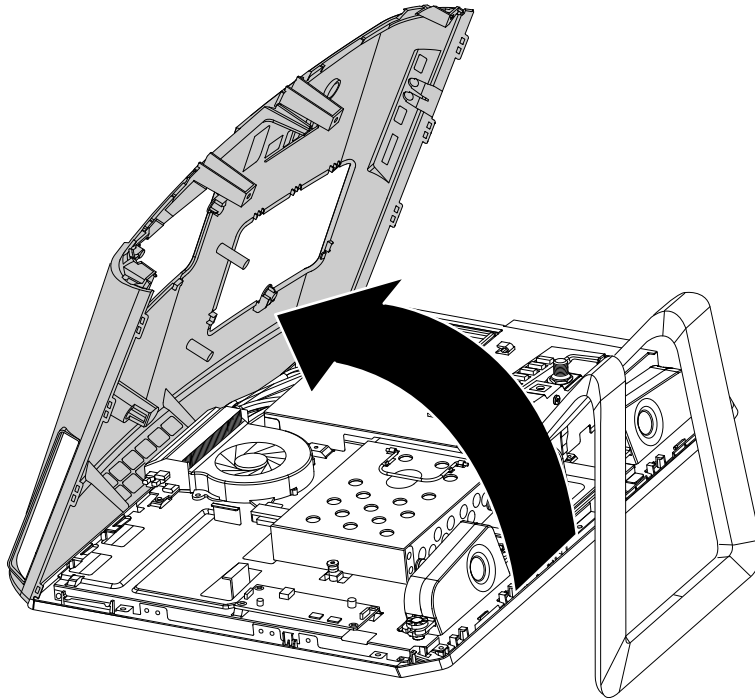

Replacing the converter board

Note: Turn off the computer and wait 3 to 5 minutes to let the computer cool down before removing the computer cover.

Note: It may be helpful to place the computer face-down on a soft flat surface for this procedure. Lenovo recommends that you use a blanket, towel, or other soft cloth to protect the computer screen from scratches or other damage.

To replace the converter board:

- Step 1. Remove any media (disks, CDs, or memory cards) from the drives, shut down the operating system, and turn off the computer and all attached devices.
- Step 2. Unplug all power cords from electrical outlets.
- Step 3. Disconnect all cables attached to the computer. This includes power cords, input/output (I/O) cables, and any other cables that are connected to the computer. Refer to “Left and right view” and “Rear view” for help with locating the various connectors.
- Step 4. Remove the optical drive. Refer to “Replacing the optical drive”.
- Step 5. Remove the hard disk drive cover. Refer to “Replacing the hard disk drive”.
- Step 6. Remove the speaker cover. Refer to “Removing the speaker cover”.
- Step 7. Remove the computer cover. Refer to “Removing the computer cover”.
- Step 8. Remove the 3 screws that secure the converter board to the chassis.
- Step 9. Disconnect the 2 cables from the converter board and lift up the converter board.

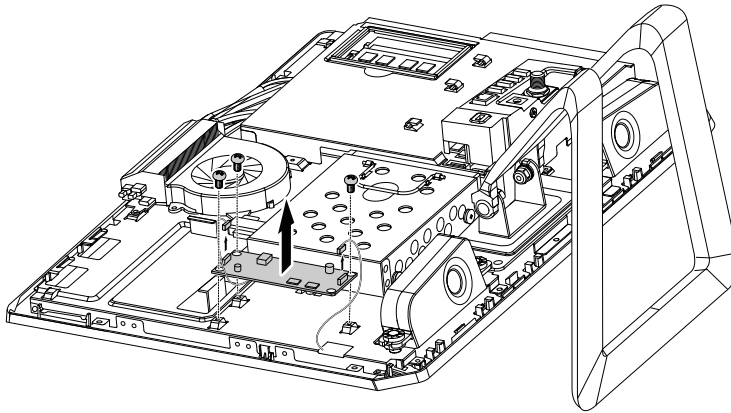

Step 10. Connect the cables to the new converter board.

Step 11. Line up the new converter board then secure it with the screws.

Step 12. Reattach the computer cover, the speaker cover, the hard disk drive cover and the optical disk drive.

Removing the computer stand

Note: Turn off the computer and wait 3 to 5 minutes to let the computer cool down before removing the computer cover.

Note: It may be helpful to place the computer face-down on a soft flat surface for this procedure. Lenovo recommends that you use a blanket, towel, or other soft cloth to protect the computer screen from scratches or other damage.

To remove the computer stand

Step 1. Remove any media (disks, CDs, or memory cards) from the drives, shut down the operating system, and turn off the computer and all attached devices.

Step 2. Unplug all power cords from electrical outlets.

Step 3. Disconnect all cables attached to the computer. This includes power cords, input/output (I/O) cables, and any other cables that are connected to the computer. Refer to “Left and right view” and “Rear view” for help with locating the various connectors.

Step 4. Remove the optical drive. Refer to “Replacing the optical drive”.

Step 5. Remove the hard disk drive. Refer to “Replacing the hard disk drive”.

Step 6. Remove the speaker cover. Refer to “Removing the speaker cover”.

Step 7. Remove the computer cover. Refer to “Removing the computer cover”.

Step 8. Remove the hard disk drive connector as shown. **1 2 3**

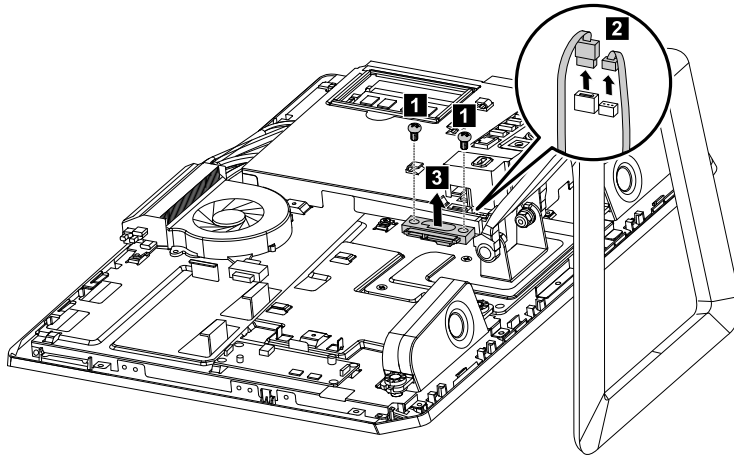

Step 9. Remove the 5 screws that secure the stand to the chassis, and then lift up the stand to remove.

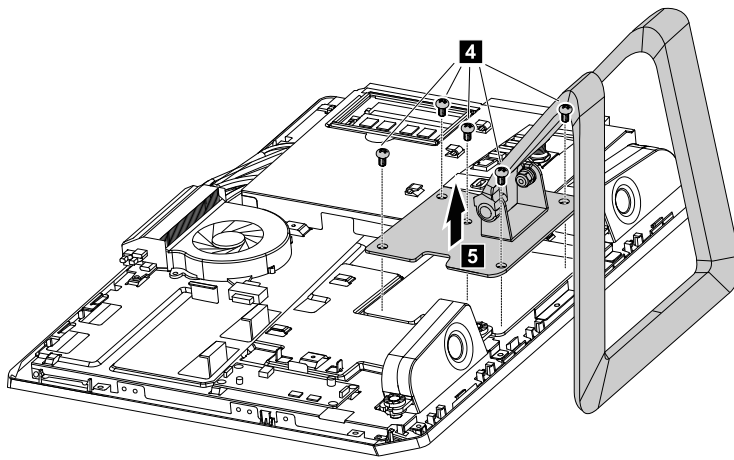

Removing the EMI cover

Note: Turn off the computer and wait 3 to 5 minutes to let the computer cool down before removing the computer cover.

Note: It may be helpful to place the computer face-down on a soft flat surface for this procedure. Lenovo recommends that you use a blanket, towel, or other soft cloth to protect the computer screen from scratches or other damage.

To replace the EMI cover

- Step 1. Remove any media (disks, CDs, or memory cards) from the drives, shut down the operating system, and turn off the computer and all attached devices.
- Step 2. Unplug all power cords from electrical outlets.
- Step 3. Disconnect all cables attached to the computer. This includes power cords, input/output (I/O) cables, and any other cables that are connected to the computer. Refer to “Left and right view” and “Rear view” for help with locating the various connectors.
- Step 4. Remove the optical drive. Refer to “Replacing the optical drive”.
- Step 5. Remove the hard disk drive cover. Refer to “Replacing the hard disk drive”.
- Step 6. Remove the speaker cover. Refer to “Removing the speaker cover”.
- Step 7. Remove the computer cover. Refer to “Removing the computer cover”.

Step 8. Remove the 11 screws (C220 /C225) /10 screws (C320/C325) that secure the EMI cover to the chassis and lift the cover up to remove.

For models C220 and C225 refer to the below illustration.

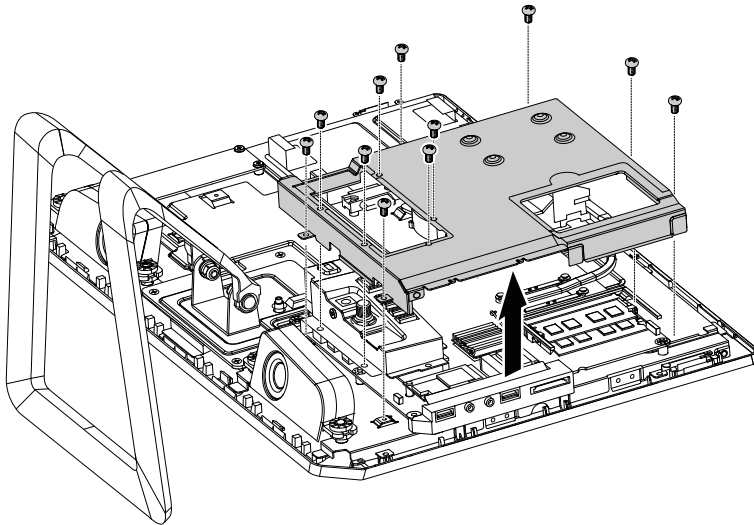

For model C320/C325 refer to the below illustration.

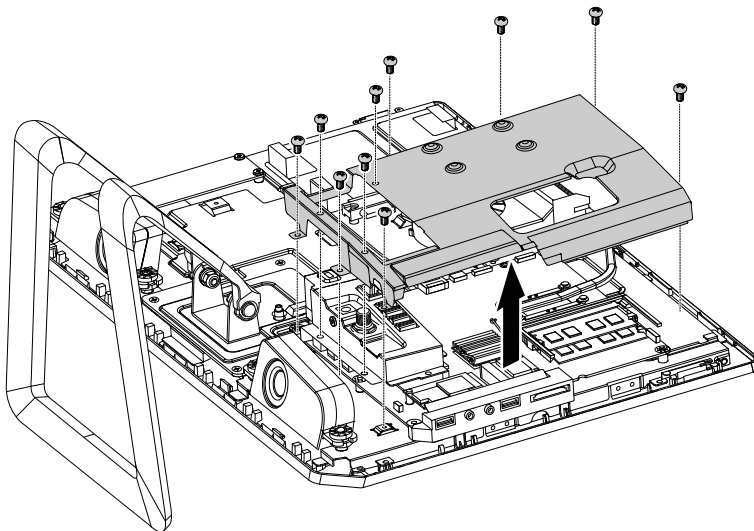

Replacing the system fan

Note: Turn off the computer and wait 3 to 5 minutes to let the computer cool down before removing the computer cover.

Note: It may be helpful to place the computer face-down on a soft flat surface for this procedure. Lenovo recommends that you use a blanket, towel, or other soft cloth to protect the computer screen from scratches or other damage.

To replace the system fan(C225/C325/C320)

Step 1. Remove any media (disks, CDs, or memory cards) from the drives, shut down the operating system, and turn off the computer and all attached devices.

- Step 2. Unplug all power cords from electrical outlets.
- Step 3. Disconnect all cables attached to the computer. This includes power cords, input/output (I/O) cables, and any other cables that are connected to the computer. Refer to “Left and right view” and “Rear view” for help with locating the various connectors.
- Step 4. Remove the optical drive. Refer to “Replacing the optical drive”.
- Step 5. Remove the hard disk drive cover. Refer to “Replacing the hard disk drive”.
- Step 6. Remove the speaker cover. Refer to “Removing the speaker cover”.
- Step 7. Remove the computer cover. Refer to “Removing the computer cover”.
- Step 8. Remove the EMI cover. Refer to “ Removing the EMI Cover”.
- Step 9. Disconnect the power cable from the motherboard.
- Step 10. Remove the 3 screws that secure the system fan to the chassis and lift the system fan up to remove it.

For models C225 and C325 refer to the below illustration.

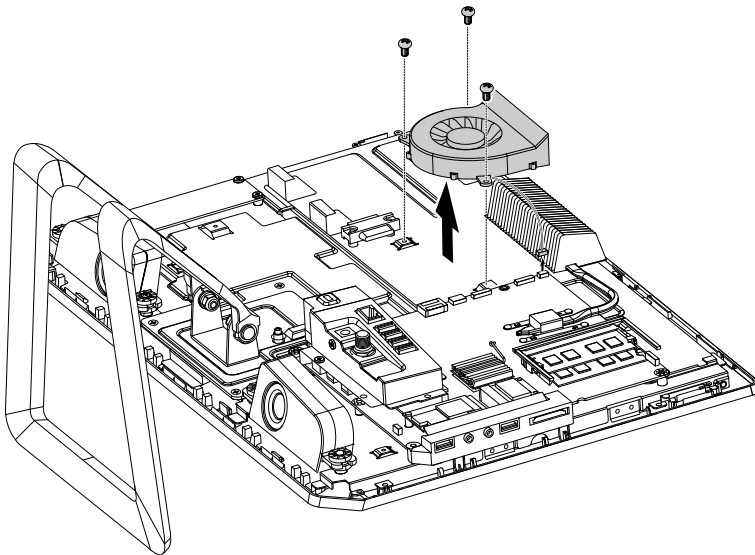

For model C320 refer to the below illustration.

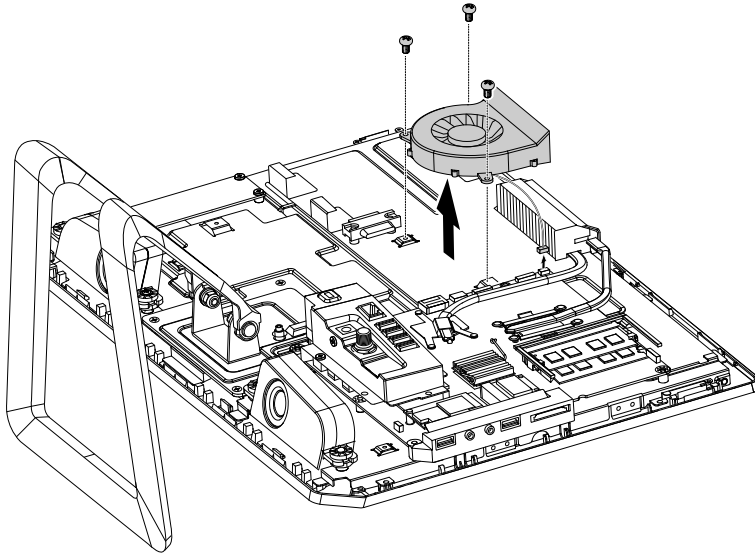

- Step 11. Line up the new system fan then secure it to the chassis and connect the new power cable to the motherboard.
- Step 12. Reattach the EMI cover, the computer cover, the speaker cover, the hard disk drive cover and the optical disk drive.

Replacing the TV tuner card

Note: Turn off the computer and wait 3 to 5 minutes to let the computer cool down before removing the computer cover.

Note: It may be helpful to place the computer face-down on a soft flat surface for this procedure. Lenovo recommends that you use a blanket, towel, or other soft cloth to protect the computer screen from scratches or other damage.

To replace the TV tuner card

- Step 1. Remove any media (disks, CDs, or memory cards) from the drives, shut down the operating system, and turn off the computer and all attached devices.
- Step 2. Unplug all power cords from electrical outlets.
- Step 3. Disconnect all cables attached to the computer. This includes power cords, input/output (I/O) cables, and any other cables that are connected to the computer. Refer to “Left and right view” and “Rear view” for help with locating the various connectors.
- Step 4. Remove the optical drive. Refer to “Replacing the optical drive”.
- Step 5. Remove the hard disk drive cover. Refer to “Replacing the hard disk drive”.
- Step 6. Remove the speaker cover. Refer to “Removing the speaker cover”.
- Step 7. Remove the computer cover. Refer to “Removing the computer cover”.
- Step 8. Remove the EMI cover. Refer to “Removing the EMI Cover”.
- Step 9. Disconnect the antenna cable from the TV tuner card.
- Step 10. Remove the screw that secures the TV tuner card to the motherboard.
- Step 11. Pull the TV tuner card upward to remove it from the card port.

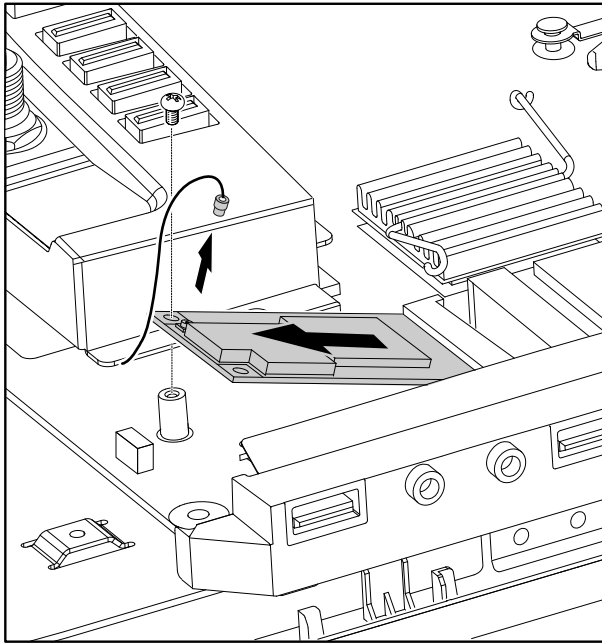

Step 12. Connect the antenna cable to the new TV tuner card.

Step 13. Reattach the EMI cover, the computer cover, the speaker cover, the hard disk drive cover and the optical disk drive.

Replacing the WLAN card

Note: Turn off the computer and wait 3 to 5 minutes to let the computer cool down before removing the computer cover.

Note: It may be helpful to place the computer face-down on a soft flat surface for this procedure. Lenovo recommends that you use a blanket, towel, or other soft cloth to protect the computer screen from scratches or other damage.

To replace the WLAN card:

- Step 1. Remove any media (disks, CDs, or memory cards) from the drives, shut down the operating system, and turn off the computer and all attached devices.
- Step 2. Unplug all power cords from electrical outlets.
- Step 3. Disconnect all cables attached to the computer. This includes power cords, input/output (I/O) cables, and any other cables that are connected to the computer. Refer to “Left and right view” and “Rear view” for help with locating the various connectors.
- Step 4. Remove the optical drive. Refer to “Replacing the optical drive”.
- Step 5. Remove the hard disk drive cover. Refer to “Replacing the hard disk drive”.
- Step 6. Remove the speaker cover. Refer to “Removing the speaker cover”.
- Step 7. Remove the computer cover. Refer to “Removing the computer cover”.
- Step 8. Remove the EMI cover. Refer to “Removing the EMI Cover”.
- Step 9. Disconnect the 2 antenna cables from the WLAN card.
- Step 10. Remove the screw that secures the WLAN card to the motherboard.
- Step 11. Pull the WLAN card upward to remove it from the card port.

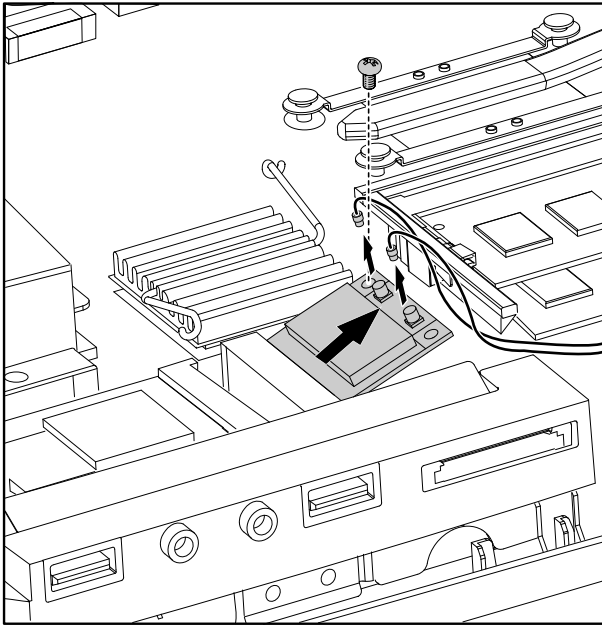

- Step 12. Align then insert the new WLAN card to the card port and secure it to the motherboard with the screw.
- Step 13. Connect the 2 antenna cables to the new WLAN card.
- Step 14. Reattach the EMI cover, the computer cover, the speaker cover, the hard disk drive cover and the optical disk drive.

Replacing the heatsink

Note: Turn off the computer and wait 3 to 5 minutes to let the computer cool down before removing the computer cover.

Note: It may be helpful to place the computer face-down on a soft flat surface for this procedure. Lenovo recommends that you use a blanket, towel, or other soft cloth to protect the computer screen from scratches or other damage.

To replace the heatsink

- Step 1. Remove any media (disks, CDs, or memory cards) from the drives, shut down the operating system, and turn off the computer and all attached devices.
- Step 2. Unplug all power cords from electrical outlets.
- Step 3. Disconnect all cables attached to the computer. This includes power cords, input/output (I/O) cables, and any other cables that are connected to the computer. Refer to “Left and right view” and “Rear view” for help with locating the various connectors.
- Step 4. Remove the optical drive. Refer to “Replacing the optical drive”.
- Step 5. Remove the hard disk drive cover. Refer to “Replacing the hard disk drive”.
- Step 6. Remove the speaker cover. Refer to “Removing the speaker cover”.
- Step 7. Remove the computer cover. Refer to “Removing the computer cover”.
- Step 8. Remove the EMI cover. Refer to “Removing the EMI Cover”.
- Step 9. Remove the 5 screws(C220/C225/C325) / 8 screws(C320) that secure the heatsink to the motherboard and chassis.
- Step 10. Remove the heatsink by lifting it up.

For model C220 refer to the below illustration.

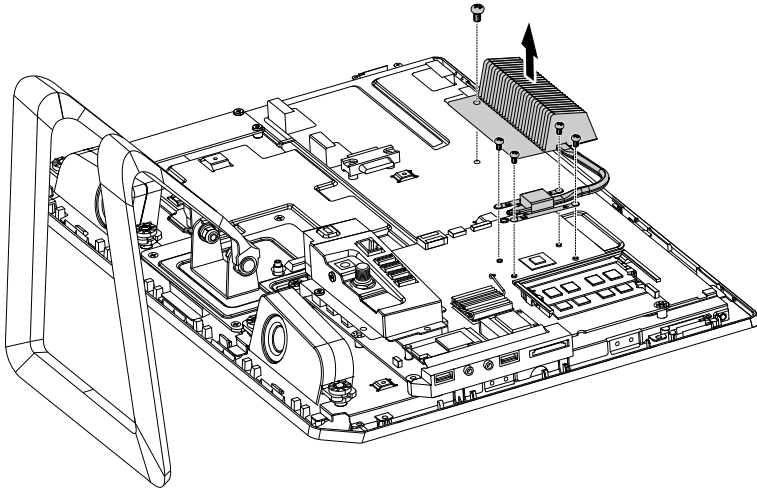

For models C225 and C325 refer to the below illustration.

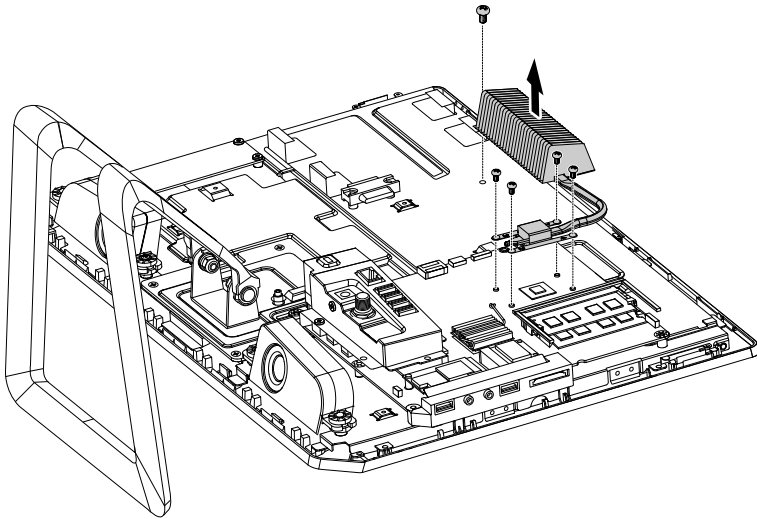

For model C320 refer to the below illustration.

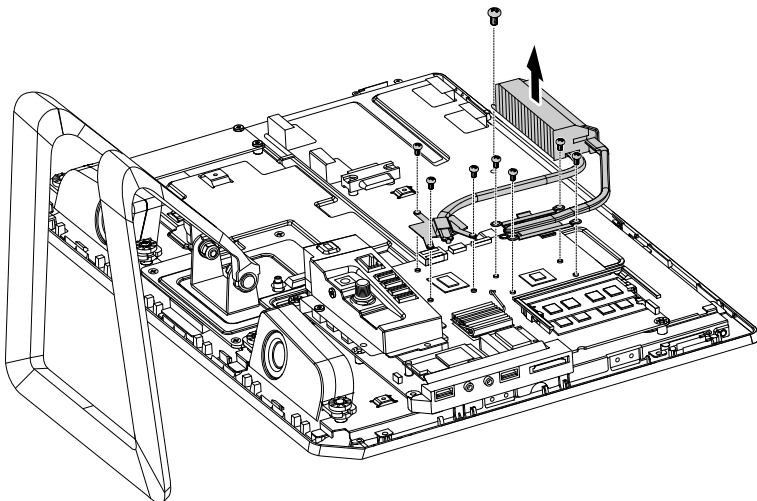

Step 11. Line up the new heatsink then secure it to the motherboard with the screws.

Step 12. Reattach the EMI cover, the computer cover, the speaker cover, the hard disk drive cover and the optical disk drive.

Replacing the CPU

Note: Turn off the computer and wait 3 to 5 minutes to let the computer cool down before removing the computer cover.

Note: It may be helpful to place the computer face-down on a soft flat surface for this procedure. Lenovo recommends that you use a blanket, towel, or other soft cloth to protect the computer screen from scratches or other damage.

To replace the CPU

Important: The following description applies for model C320 only.

Step 1. Remove any media (disks, CDs, or memory cards) from the drives, shut down the operating system, and turn off the computer and all attached devices.

Step 2. Unplug all power cords from electrical outlets.

Step 3. Disconnect all cables attached to the computer. This includes power cords, input/output (I/O) cables, and any other cables that are connected to the computer. Refer to “Left and right view” and “Rear view” for help with locating the various connectors.

Step 4. Remove the optical drive. Refer to “Replacing the optical drive”.

Step 5. Remove the hard disk drive cover. Refer to “Replacing the hard disk drive”.

Step 6. Remove the speaker cover. Refer to “Removing the speaker cover”.

Step 7. Remove the computer cover. Refer to “Removing the computer cover”.

Step 8. Remove the EMI cover. Refer to “Removing the EMI Cover”.

Step 9. Remove the heatsink. Refer to “Replacing the heatsink”.

Step 10. Lift the small handle and open the retainer.

Step 11. Lift the microprocessor straight up and out of the socket.

Attention: Do not touch the gold contacts on the bottom of the microprocessor. When handling the microprocessor, touch only the sides.

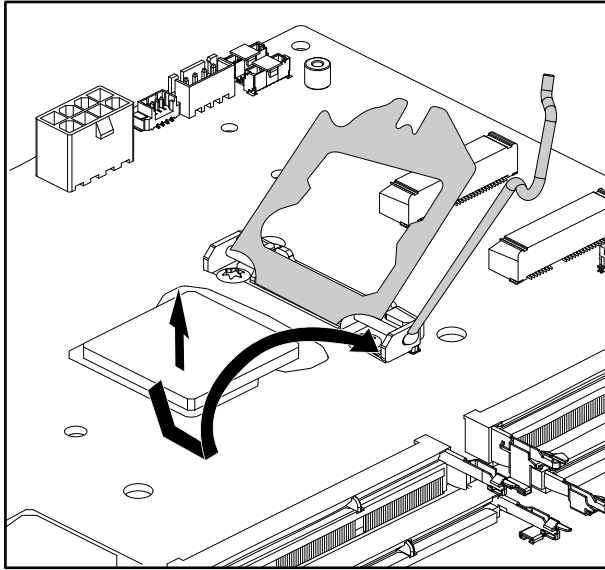

Note: Note the orientation of the notches 1 on the microprocessor. This is important when installing the new microprocessor on the motherboard. **1**

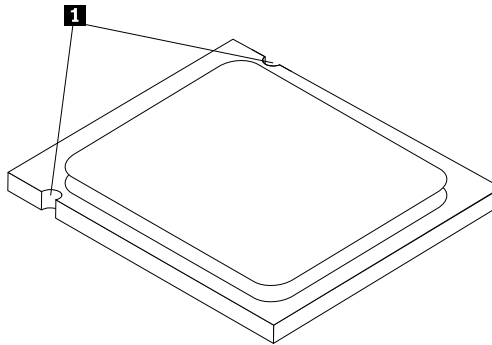

Note: Do not drop anything onto the microprocessor socket while it is exposed. The socket pins must be kept as clean as possible.

- Step 12. Make sure that the microprocessor retainer is fully open.
- Step 13. Holding the sides of the microprocessor with your fingers, remove the protective cover 2 that protects the gold contacts on the new microprocessor 1. **1 2**

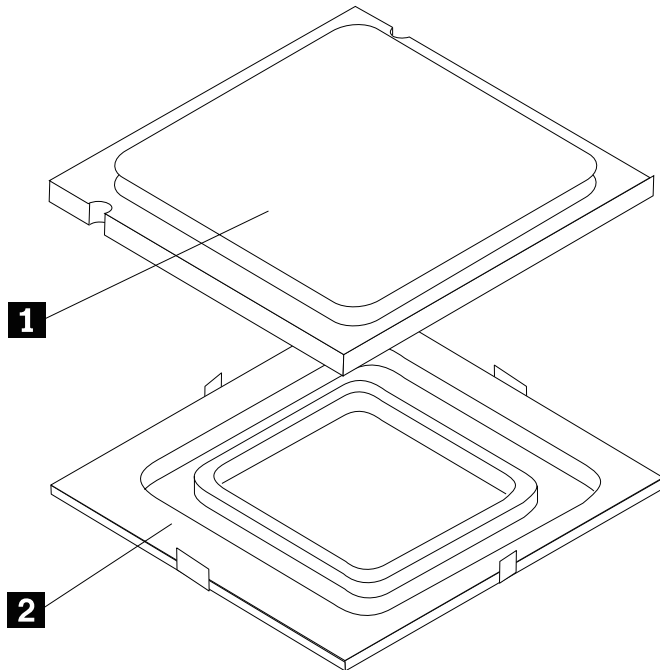

Step 14. Holding the sides of the microprocessor with your fingers, position the microprocessor so that the notches on the microprocessor are aligned with the tabs in the microprocessor socket.

Important: To avoid damaging the microprocessor contacts, keep the microprocessor completely level while installing it into the socket.

Step 15. Lower the microprocessor straight down into its socket on the motherboard.

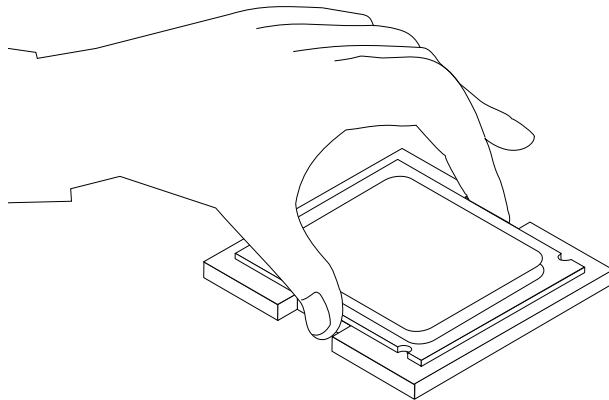

Step 16. To secure the microprocessor in the socket, close the microprocessor retainer and lock it into position with the small handle.

Step 17. Use a thermal grease syringe to place 5 drops of grease on the top of the microprocessor. Each drop of grease should be 0.03ml (3 tick marks on the grease syringe).

Step 18. Reattach the heatsink, the EMI cover, the computer cover, the speaker cover, the hard disk drive cover and the optical disk drive.

Replacing the rear I/O module

Note: Turn off the computer and wait 3 to 5 minutes to let the computer cool down before removing the computer cover.

Note: It may be helpful to place the computer face-down on a soft flat surface for this procedure. Lenovo recommends that you use a blanket, towel, or other soft cloth to protect the computer screen from scratches or other damage.

To replace the rear I/O module

- Step 1. Remove any media (disks, CDs, or memory cards) from the drives, shut down the operating system, and turn off the computer and all attached devices.
- Step 2. Unplug all power cords from electrical outlets.
- Step 3. Disconnect all cables attached to the computer. This includes power cords, input/output (I/O) cables, and any other cables that are connected to the computer. Refer to “Left and right view” and “Rear view” for help with locating the various connectors.
- Step 4. Remove the optical drive. Refer to “Replacing the optical drive”.
- Step 5. Remove the hard disk drive cover. Refer to “Replacing the hard disk drive”.
- Step 6. Remove the speaker cover. Refer to “Removing the speaker cover”.
- Step 7. Remove the computer cover. Refer to “Removing the computer cover”.
- Step 8. Remove the EMI cover. Refer to “Removing the EMI Cover”.
- Step 9. Remove the 2 screws that secure the rear I/O module to the motherboard.
- Step 10. Disconnect the power cable from motherboard and TV antenna cable(s) from TV tuner card.

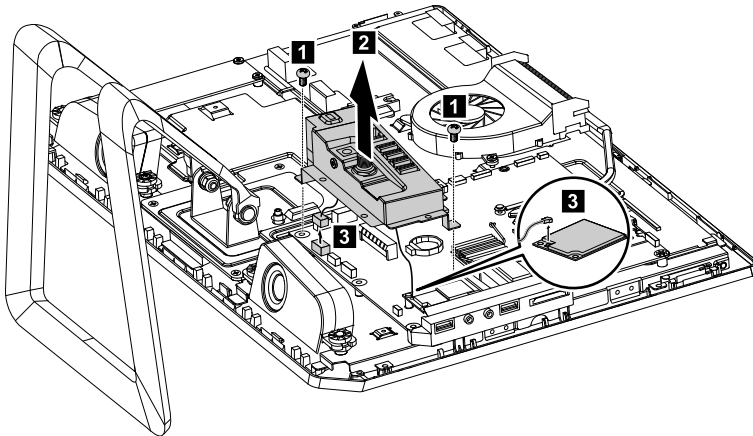

- Step 11. Remove the screws that secure the rear I/O module to the metal bracket and slide it out to remove.

For models C220 and C225 refer to the below illustration. (2 screws)

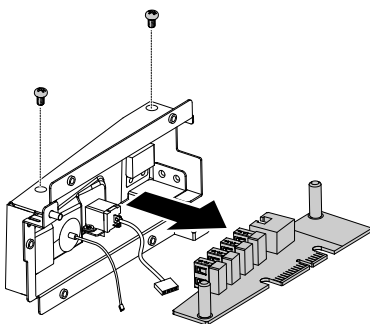

For models C320 and C325 refer to the below illustration. (3 screws)

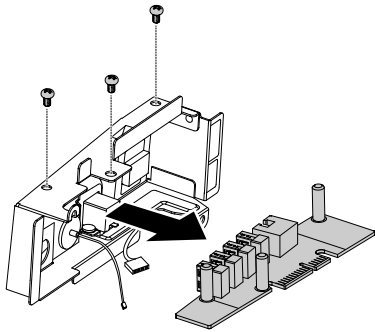

Step 12. Line the new I/O module up then slide it into the metal bracket.

Step 13. Line the new I/O module and metal bracket up with the chassis then secure it with the screws.

Step 14. Connect the power cable to the motherboard and TV antenna cable(s) to the TV tuner card.

Step 15. Reattach the EMI cover, the computer cover, the speaker cover, the hard disk drive cover and the optical disk drive.

Replacing the speaker system

Note: Turn off the computer and wait 3 to 5 minutes to let the computer cool down before removing the computer cover.

Note: It may be helpful to place the computer face-down on a soft flat surface for this procedure. Lenovo recommends that you use a blanket, towel, or other soft cloth to protect the computer screen from scratches or other damage.

To replace the speaker system:

Step 1. Remove any media (disks, CDs, or memory cards) from the drives, shut down the operating system, and turn off the computer and all attached devices.

Step 2. Unplug all power cords from electrical outlets.

Step 3. Disconnect all cables attached to the computer. This includes power cords, input/output (I/O) cables, and any other cables that are connected to the computer. Refer to “Left and right view” and “Rear view” for help with locating the various connectors.

Step 4. Remove the optical drive. Refer to “Replacing the optical drive”.

Step 5. Remove the hard disk drive cover. Refer to “Replacing the hard disk drive”.

Step 6. Remove the speaker cover. Refer to “Removing the speaker cover”.

Step 7. Remove the computer cover. Refer to “Removing the computer cover”.

Step 8. Remove the EMI cover. Refer to “Removing the EMI Cover”.

Step 9. Remove the 4 screws that secure the speakers to the chassis, disconnect the data cables from the motherboard and lift up the speakers to remove.

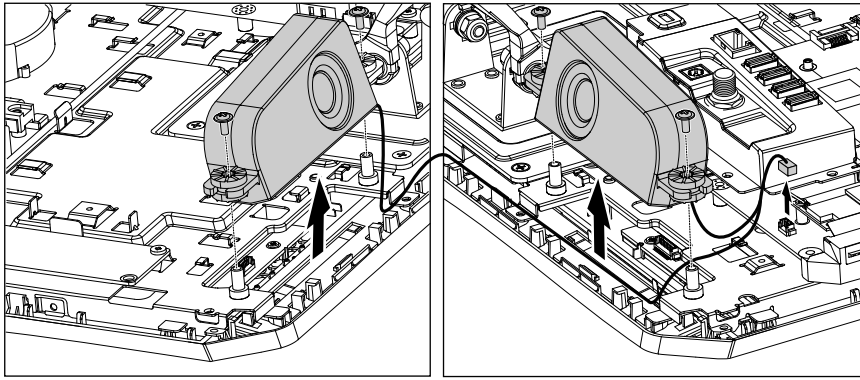

Step 10. Line up the new speaker system with the chassis then secure it using the screws.

Step 11. Connect the new speaker cables to the motherboard.

Step 12. Reattach the EMI cover, the computer cover, the speaker cover, the hard disk drive cover and the optical disk drive.

Replacing the motherboard

Note: Turn off the computer and wait 3 to 5 minutes to let the computer cool down before removing the computer cover.

Note: It may be helpful to place the computer face-down on a soft flat surface for this procedure. Lenovo recommends that you use a blanket, towel, or other soft cloth to protect the computer screen from scratches or other damage.

To replace the motherboard:

- Step 1. Remove any media (disks, CDs, or memory cards) from the drives, shut down the operating system, and turn off the computer and all attached devices.
- Step 2. Unplug all power cords from electrical outlets.
- Step 3. Disconnect all cables attached to the computer. This includes power cords, input/output (I/O) cables, and any other cables that are connected to the computer. Refer to “Left and right view” and “Rear view” for help with locating the various connectors.
- Step 4. Remove the memory module. Refer to “Replacing a memory module”.
- Step 5. Remove the optical drive. Refer to “Replacing the optical drive”.
- Step 6. Remove the hard disk drive cover. Refer to “Replacing the hard disk drive”.
- Step 7. Remove the speaker cover. Refer to “Removing the speaker cover”.
- Step 8. Remove the computer cover. Refer to “Removing the computer cover”.
- Step 9. Remove the EMI cover. Refer to “Removing the EMI Cover”.
- Step 10. Remove the heatsink. Refer to “Replacing the heatsink”.
- Step 11. Remove the CPU. Refer to “Replacing the CPU”.(C320 only)
- Step 12. Remove the TV tuner card. Refer to “Replacing the TV tuner card”.
- Step 13. Remove the WLAN card. Refer to “Replacing the WLAN card”.
- Step 14. Remove the rear I/O module. Refer to “Replacing the I/O module”.
- Step 15. Remove all the cables connected to the motherboard.
- Step 16. Remove the screws that secure the motherboard to the chassis and lift up the motherboard to remove.

For models C220 refer to the below illustration. (7 screws)

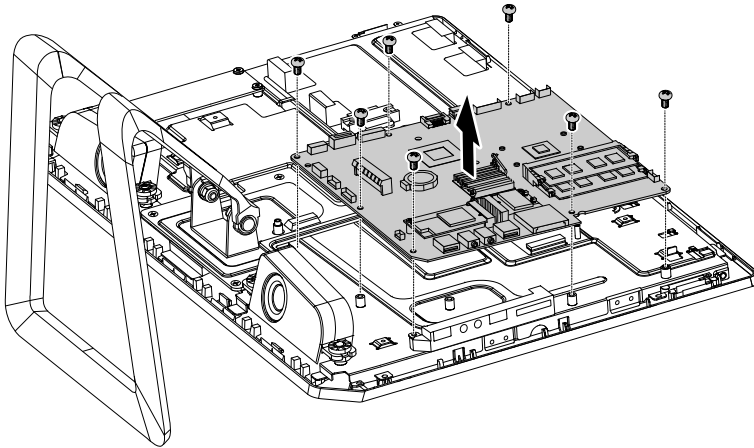

For models C225 and C325 refer to the below illustration. (7 screws)

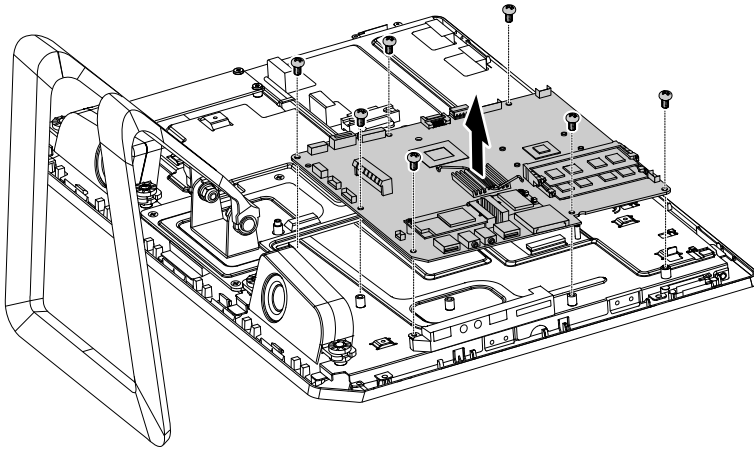

For models C320 refer to the below illustration. (9 screws)

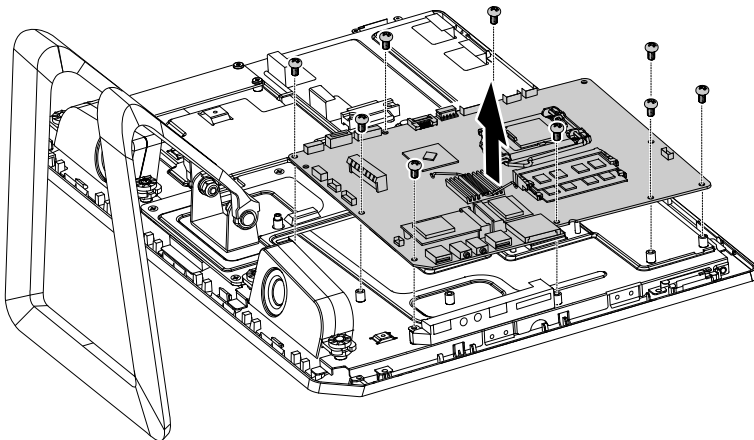

Step 17. Place the new motherboard into the chassis, aligning the screw holes in the motherboard with the mounting holes in the chassis.

Step 18. Secure the new motherboard to the chassis using the screws.

Step 19. Attach all related components to the new motherboard.

Step 20. Reattach the EMI cover, the computer cover, the speaker cover, the hard disk drive cover and the optical disk drive.

Replacing the camera

Note: Turn off the computer and wait 3 to 5 minutes to let the computer cool down before removing the computer cover.

Note: It may be helpful to place the computer face-down on a soft flat surface for this procedure. Lenovo recommends that you use a blanket, towel, or other soft cloth to protect the computer screen from scratches or other damage.

To replace the camera:

- Step 1. Remove any media (disks, CDs, or memory cards) from the drives, shut down the operating system, and turn off the computer and all attached devices.
- Step 2. Unplug all power cords from electrical outlets.
- Step 3. Disconnect all cables attached to the computer. This includes power cords, input/output (I/O) cables, and any other cables that are connected to the computer. Refer to “Left and right view” and “Rear view” for help with locating the various connectors.
- Step 4. Remove the optical drive. Refer to “Replacing the optical drive”.
- Step 5. Remove the hard disk drive cover. Refer to “Replacing the hard disk drive”.
- Step 6. Remove the speaker cover. Refer to “Removing the speaker cover”.
- Step 7. Remove the computer cover. Refer to “Removing the computer cover”.
- Step 8. Remove the 2 screws that secure the camera to the front bezel.
- Step 9. Lift up the camera and disconnect the data cable from the camera.

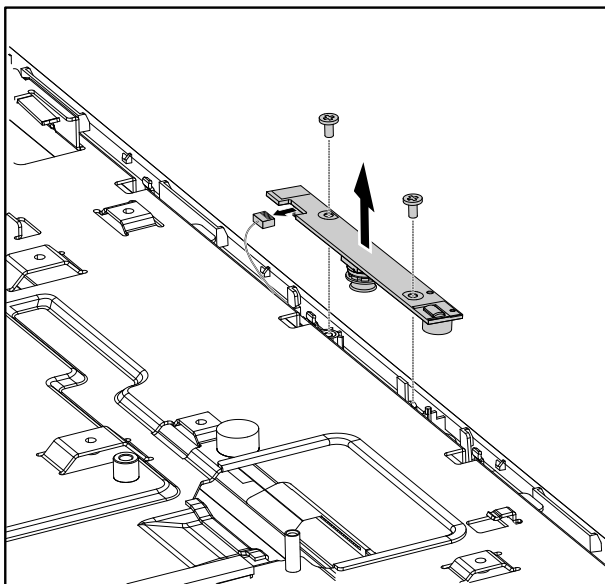

- Step 10. Connect the data cable to the new camera.
- Step 11. Line up the new camera with front bezel and secure it with the 2 screws.
- Step 12. Reattach the computer cover, the speaker cover, the hard disk drive cover and the optical disk drive.

Replacing the front indicator and power button board

Note: Turn off the computer and wait 3 to 5 minutes to let the computer cool down before removing the computer cover.

Note: It may be helpful to place the computer face-down on a soft flat surface for this procedure. Lenovo recommends that you use a blanket, towel, or other soft cloth to protect the computer screen from scratches or other damage.

To replace the front indicator and power button board:

- Step 1. Remove any media (disks, CDs, or memory cards) from the drives, shut down the operating system, and turn off the computer and all attached devices.
- Step 2. Unplug all power cords from electrical outlets.
- Step 3. Disconnect all cables attached to the computer. This includes power cords, input/output (I/O) cables, and any other cables that are connected to the computer. Refer to “Left and right view” and “Rear view” for help with locating the various connectors.
- Step 4. Remove the optical drive. Refer to “Replacing the optical drive”.
- Step 5. Remove the hard disk drive cover. Refer to “Replacing the hard disk drive”.
- Step 6. Remove the speaker cover. Refer to “Removing the speaker cover”.
- Step 7. Remove the computer cover. Refer to “Removing the computer cover”.
- Step 8. Remove the EMI cover. Refer to “Removing the EMI Cover”.
- Step 9. Remove the speaker system. Refer to “Replacing the speaker system”.
- Step 10. Disconnect the data cable from the front indicator and power button board.
- Step 11. Remove the 2 screws that secure the front indicator and power button board to the front bezel.
- Step 12. Slide the front indicator and power button board out and lift it up to remove.

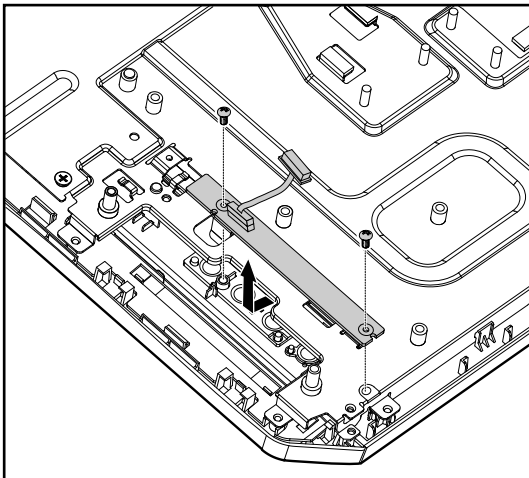

- Step 13. Slide the new the front indicator and power button board in, line it up with screw holes on the front bezel and secure it with the 2 screws.
- Step 14. Connect the data cable to the new front indicator and power button board.
- Step 15. Reattach the speaker system, the EMI cover, the computer cover, the speaker cover, the hard disk drive cover and the optical disk drive.

Replacing the front function board

Note: Turn off the computer and wait 3 to 5 minutes to let the computer cool down before removing the computer cover.

Note: It may be helpful to place the computer face-down on a soft flat surface for this procedure. Lenovo recommends that you use a blanket, towel, or other soft cloth to protect the computer screen from scratches or other damage.

To replace the front function board:

- Step 1. Remove any media (disks, CDs, or memory cards) from the drives, shut down the operating system, and turn off the computer and all attached devices.
- Step 2. Unplug all power cords from electrical outlets.
- Step 3. Disconnect all cables attached to the computer. This includes power cords, input/output (I/O) cables, and any other cables that are connected to the computer. Refer to “Left and right view” and “Rear view” for help with locating the various connectors.
- Step 4. Remove the optical drive. Refer to “Replacing the optical drive”.
- Step 5. Remove the hard disk drive cover. Refer to “Replacing the hard disk drive”.
- Step 6. Remove the speaker cover. Refer to “Removing the speaker cover”.
- Step 7. Remove the computer cover. Refer to “Removing the computer cover”.
- Step 8. Remove the EMI cover. Refer to “Removing the EMI Cover”.
- Step 9. Remove the speaker system. Refer to “Replacing the speaker system”.
- Step 10. Disconnect the data cable from the front function board.
- Step 11. Remove the 2 screws that secure the front function board to the front bezel.
- Step 12. Slide the front function board out and lift it up to remove.

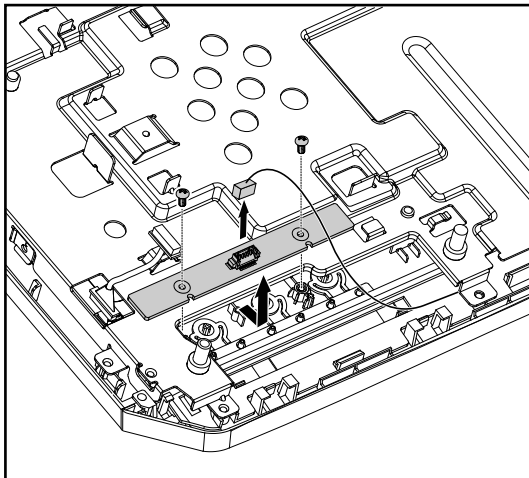

- Step 13. Slide the new front function board in, line it up with screw holes on the front bezel and secure it with the 2 screws.
- Step 14. Connect the data cable to the new front function board.
- Step 15. Reattach the speaker system, the EMI cover, the computer cover, the speaker cover, the hard disk drive cover and the optical disk drive.

Replacing the LED panel

Note: Turn off the computer and wait 3 to 5 minutes to let the computer cool down before removing the computer cover.

Note: It may be helpful to place the computer face-down on a soft flat surface for this procedure. Lenovo recommends that you use a blanket, towel, or other soft cloth to protect the computer screen from scratches or other damage.

To replace the LED panel:

- Step 1. Remove any media (disks, CDs, or memory cards) from the drives, shut down the operating system, and turn off the computer and all attached devices.
- Step 2. Unplug all power cords from electrical outlets.
- Step 3. Disconnect all cables attached to the computer. This includes power cords, input/output (I/O) cables, and any other cables that are connected to the computer. Refer to “Left and right view” and “Rear view” for help with locating the various connectors.
- Step 4. Remove the optical drive. Refer to “Replacing the optical drive”.
- Step 5. Remove the hard disk drive cover. Refer to “Replacing the hard disk drive”.
- Step 6. Remove the speaker cover. Refer to “Removing the speaker cover”.
- Step 7. Remove the computer cover. Refer to “Removing the computer cover”.
- Step 8. Remove the speaker system. Refer to “Replacing the speaker system”.
- Step 9. Disconnect the 3 cables as shown.

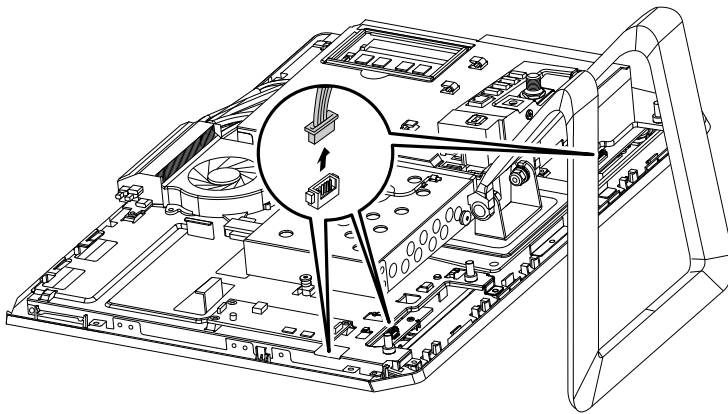

- Step 10. Remove the 15 screws that secure the chassis to the front bezel.

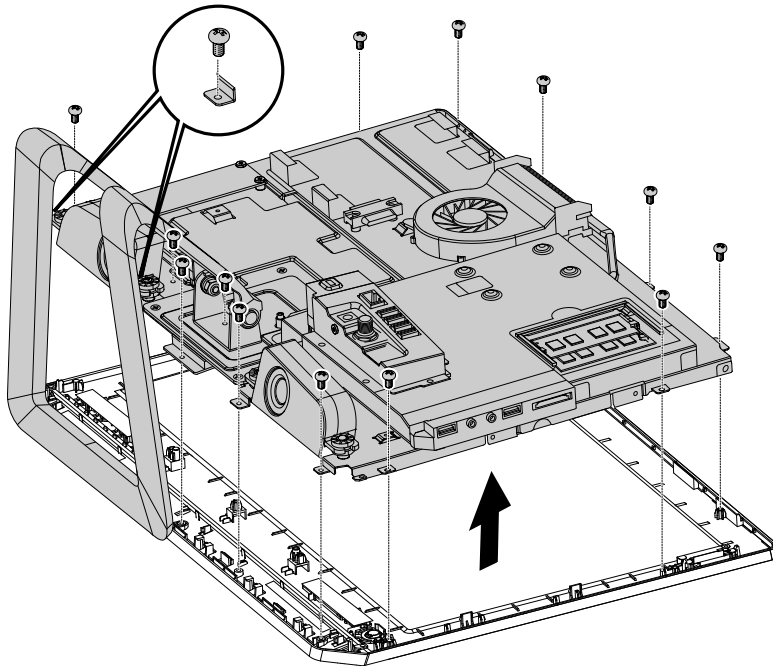

Step 11. Remove the 4 screws that secure the LED panel to the chassis **1** and disconnect the signal cable from the LED panel to remove the LED panel from the chassis. **2**

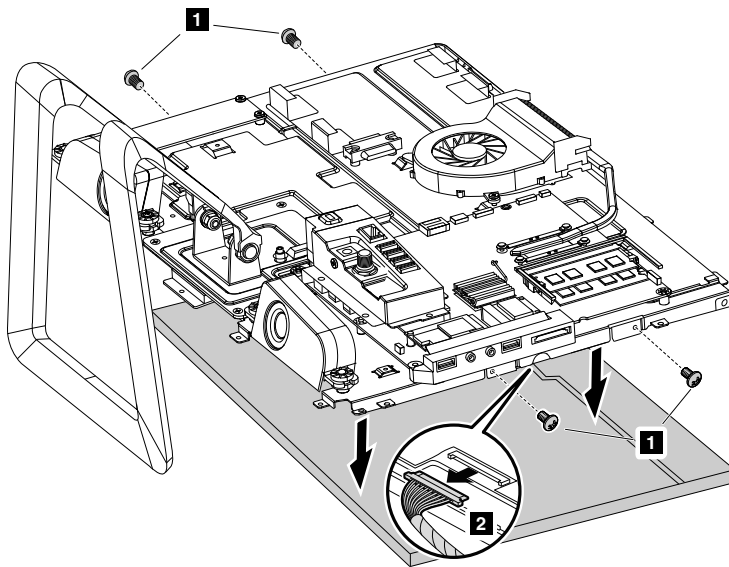

Step 12. Connect the signal cable to the new LED panel.

Step 13. Align the 4 mounting holes on the LED panel brackets with the holes in the chassis and secure it to the chassis with the 4 screws.

Step 14. Align the mounting holes on the chassis with holes on the front bezel and secure it with 15 screws.

Step 15. Reattach the speaker system, EMI cover, the computer cover, the speaker cover, the hard disk drive cover and the optical disk drive.

Chapter 8. Additional Service Information

This chapter provides additional information that the service representative might find helpful.

Power management

Power management reduces the power consumption of certain components of the computer such as the system power supply, processor, hard disk drives, and some monitors.

Automatic configuration and power interface (ACPI) BIOS

Being an ACPI BIOS system, the operating system is allowed to control the power management features of the computer and the setting for Advanced Power Management (APM) BIOS mode is ignored. Not all operating systems support ACPI BIOS mode.

Automatic Power-On features

The Automatic Power-On features within the Power Management menu allow you to enable and disable features that turn on the computer automatically.

- Resume On RTC Alarm: You can specify a date and time at which the computer will be turned on automatically. This can be either a single event or a daily event.
- On LAN Wake Up: This feature allows LAN adapter card to wake the System.

Free Manuals Download Website

<http://myh66.com>

<http://usermanuals.us>

<http://www.somanuals.com>

<http://www.4manuals.cc>

<http://www.manual-lib.com>

<http://www.404manual.com>

<http://www.luxmanual.com>

<http://aubethermostatmanual.com>

Golf course search by state

<http://golfingnear.com>

Email search by domain

<http://emailbydomain.com>

Auto manuals search

<http://auto.somanuals.com>

TV manuals search

<http://tv.somanuals.com>