

Starrett®

**Altissimo®
Electronic Height Gage
Operation Manual**

Contents

Introduction	2
Unpacking.....	3
Setup.....	4
Probe Calibration.....	5
Establishing a Datum.....	6
Measuring Modes	
-Measuring - Height	7
-Measuring – Center.....	8
-Measuring - Diameter	9
-Measuring – TIR.....	10
Continuous Display and Scribing Mode.....	11
Setup Modes	12 - 14
Data Output	15
Symbols.....	16 - 17
Specifications	18
Care and Maintenance	
-Charging and Replacing Batteries.....	19
-Cleaning.....	20 - 21
Troubleshooting	
- Error Messages.....	22
Accessories and Replacement Order Information	23

The L.S. Starrett Company
121 Crescent Street
Athol, MA 01331 U.S.A.

The L.S. Starrett Company assumes no liability to any party for any loss or damage, direct or indirect, caused by use of this gage that is not in accordance with the instructions in this manual. Details of this document are subject to change without notice.

Rev. K - Oct 2010

Introduction

The Starrett Altissimo is a revolutionary new measuring instrument. It combines the simplicity and ease-of-use of mid-priced height gages with the features and performance of high-end height gages. It is an easy to use height gage with a dynamic probe that allows both point and scanning measurements. It provides direct calculation of Heights, Centers, Diameters, Max, Min and TIR as well as Distance Between Points and Distance to Last Feature. The Altissimo® can also be used for Scribing.

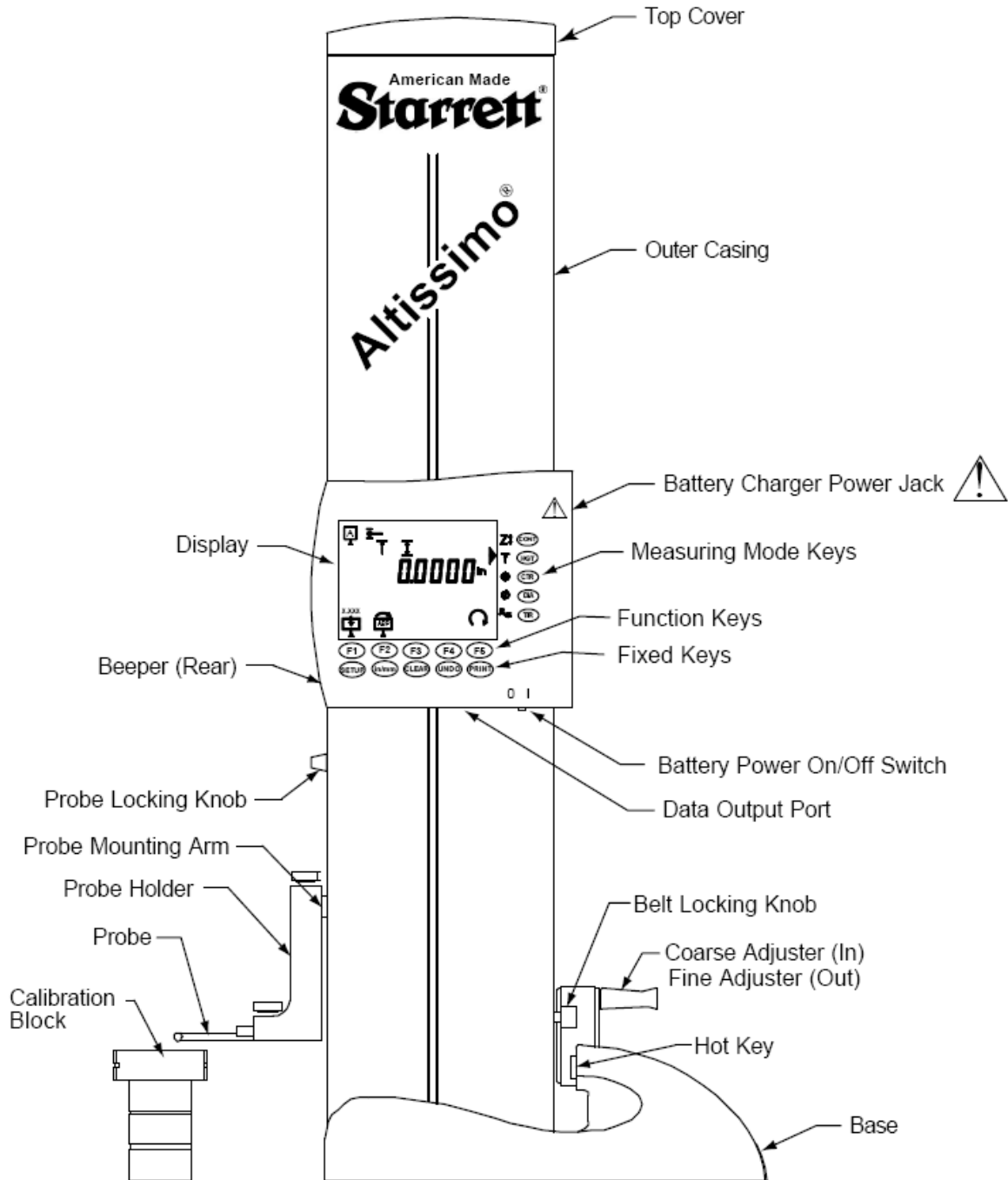

Unpacking

Checking Contents

The Altissimo is delivered in a Cardboard Box that is specially fitted to provide protection from the shock, vibration and moisture normally encountered during shipments. Keep this box for storage and future shipments of the tool.

Carefully check the contents to ensure that all items are there:

1. Height Gage
2. Probe, $\text{\O} .1875''$
3. Probe Holder
4. Calibration Block
5. Wall Mounted AC Adapter/Battery Charger
6. Operation Manual
7. Report
 - a.) With the 2000-24 a Letter of Certification is supplied.
 - b.) With the 2001-24 an Inspection Report is supplied.

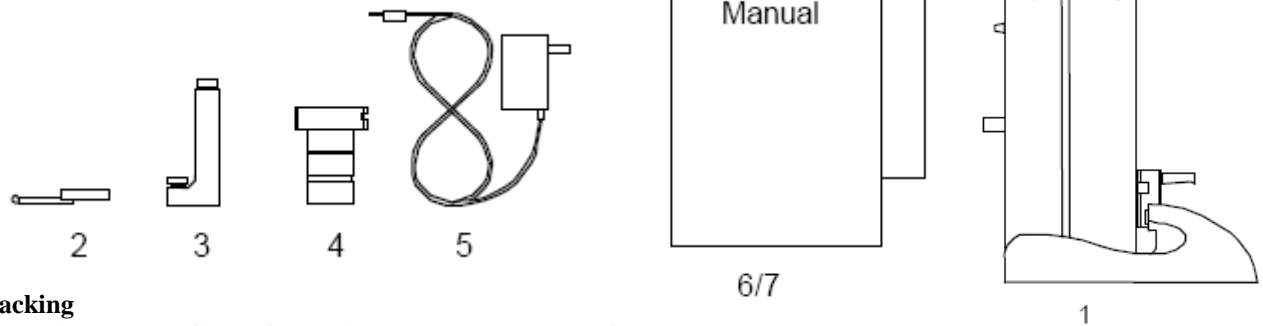

Unpacking

1. Lay the Box on a flat surface and open. Remove accessories.
2. Place the Altissimo carefully on a work surface and remove the plastic bag.
3. Wipe the bottom of the base before placing on a Surface Plate.
4. Use a $3/16''$ Hex Wrench to remove the Top Cover. (See Figure 1)
5. Use a $5/32''$ Hex Wrench to remove the Counterbalance Shipping Screw. (See Figure 2) Replace the screw in the tapped hole next to the one from which it was removed.
6. Replace the Top Cover making the screw finger tight. **Do Not Over Tighten Screw.**

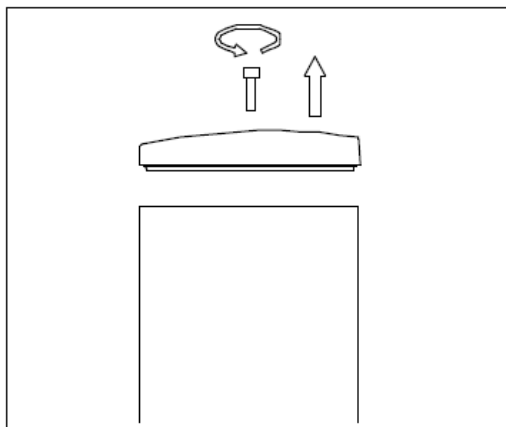

Figure 1

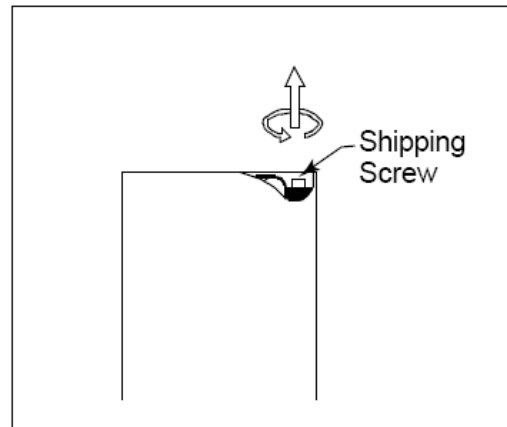

Figure 2

Setup

- 1. Charge Battery** - The Altissimo battery was fully charged at the factory, however, the battery may have discharged during shipping and storage. It is recommended to leave the charger connected for at least fourteen hours. The charging circuit is designed to provide a maintenance charge to the battery and may remain connected for the duration of use. The tool will remain ON while the charger is plugged in regardless of the position of the Battery Power ON/OFF Switch. Removing the Charger plug and reinserting will initiate another charge cycle depending on the state of charge of the battery.

If the Low Battery ICON comes on, locate the charger and plug it into the Power Jack on the right side of the Display. (Figure 3)

See Page 19 for additional Battery Charging information.



CAUTION - See Care and Maintenance section for necessary precautions.

- 2. Move Slide** - Rotate the Probe and Belt Locking Knobs counterclockwise. Using the Coarse Adjuster Knob move the Probe Mounting Arm to the center of travel. Re-lock the Belt and Probe Locking Knobs. (See Figure 4)
- 3. Mount Probe Holder** - Mount the Probe Holder onto the Mounting Arm and tighten the screw firmly. (See Figure 5)

Note: Make sure the Probe Holder is mounted vertically.

- 4. Mount Probe** - Mount the Probe into the Probe Holder and tighten the screw firmly. (See Figure 6)

Note: Make sure the Probe Tip is oriented downward so that the Probe Holder or the Probe Shank does not hit the surface plate.

- 5. Clean** - Clean the Probe Tip and the Top and Bottom measuring surfaces of the Calibration Block with Isopropyl Alcohol and lint free cotton cloth. (See Figure 7)

- 6. Lifting** - Care should be taken when lifting the Altissimo. Lock down the probe and belt (See Figure 4). Firmly grip the unit by the base and outer casing. Avoid all contact with the probe and display panel. Jarring motion may damage the gage. Do not drop.

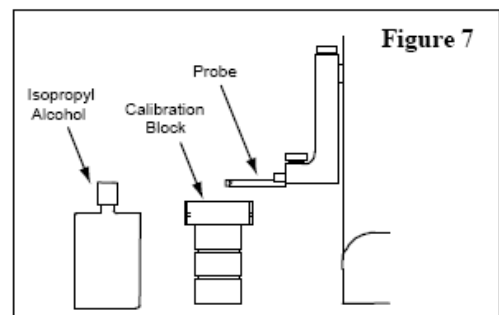
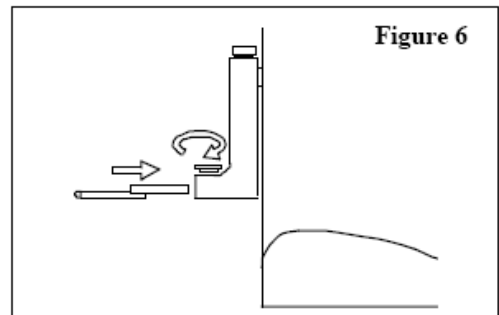
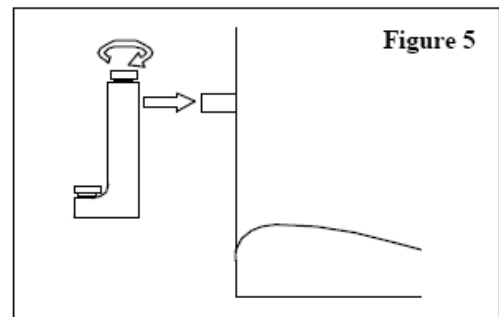
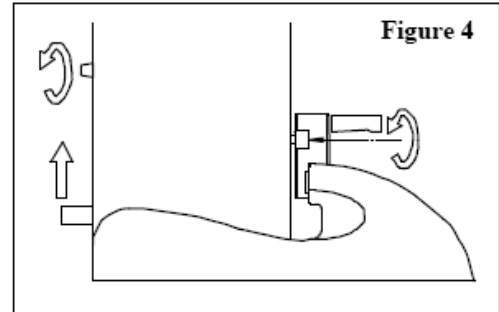
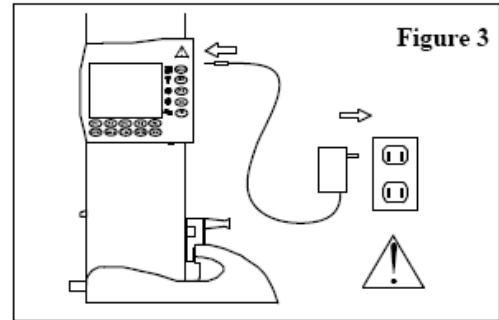

Probe Calibration

Power On - Turn the Power on, if using the Battery for power place the Battery Power On/Off switch to the 1 position or plug the charger in and the unit will power regardless of the Battery Power On/Off Switch position.

The display comes on in Height Mode and prompts for Point 1 (Pt 1). (See Figure 8)

Note: The Altissimo can be used to measure heights even if the Probe is not calibrated. See Measuring Modes – Height Section.

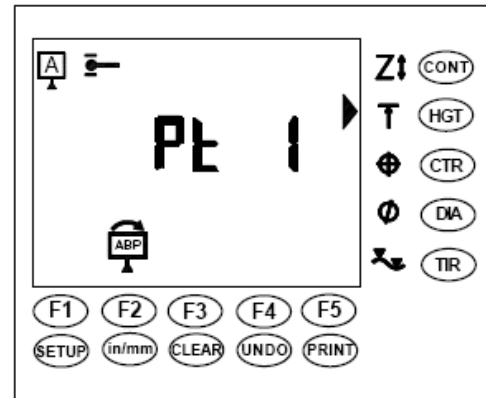

Figure 8

Probe Diameter Calibration – If the Probe Symbol is Flashing in the upper left corner of the Display, it will be necessary to Calibrate the Probe Diameter. (See Figure 9) The Probe Diameter must be recalibrated when the Altissimo is first received and periodically thereafter, especially when measuring conditions change.

Press the SETUP Key and the Probe Calibration Mode Icon will light. The display will ask for Point 1 (Cal 1). Position the Calibration Block under the Probe. Using the Coarse Adjuster Knob move the probe down onto the Upper Measuring Surface until the tool beeps. Move the Probe clear of the surface. The display will ask for Point 2 (Cal 2). Similarly measure the Lower Measuring Surface of the Calibration Block. Measure the Upper and Lower Measuring Surface a second time.

Note: In order to calculate the diameter of the probe the first and second measurements must be taken in opposite directions, the third and fourth measurements must also be taken in opposite directions.

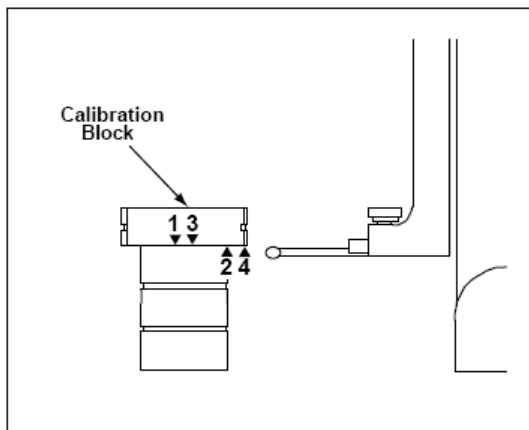

Figure 9

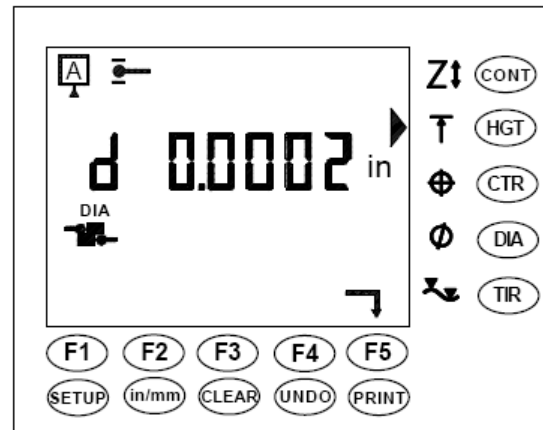



Figure 10

Accept the Calibration - After measuring each surface twice, the Altissimo will display a number which is the Deviation of the Probe Calibration. The deviation is the repeatability of the points taken during Probe Calibration. This provides a measure of the quality of the measurements. If the Deviation is sufficiently low, under .0002" (.004mm), then Press the F5 Function Key () to accept the value. (See Figure 10) The Probe Calibration Icon stops Flashing and the top and bottom "Hit" bars are Flashing indicating measurements can be made in either direction.

Note: If the Deviation is high, over .0002" (.004 mm), then check the tightness of the Probe Arm and Probe. Check the cleanliness of the Probe Tip and Calibration Block. Make sure that the Probe and Belt Locks are fully unlocked. Then recalibrate the Probe.

Important: The Altissimo will store the Calibrated Probe Diameter even after it is turned off. The Probe must be recalibrated each time it is changed or repositioned. See Setup Section for instructions on other Probe Diameter Calibration Options.

Establishing a Datum

Measure Datum – If the Datum Symbol is flashing in the upper left corner of the Display then a Datum will need to be established. Using the Coarse Adjuster Knob bring the Probe in contact with the surface plate or other datum surface until it Beeps. (See Figure 11) Move the Probe clear of the surface. Press the F1 key to set the Active Datum to 0 at the last measured point. (See Figure 12)

Note: If the probe is not calibrated the Altissimo may be used in the Unidirectional Height mode. Simply take a measurement in either direction, Press the F1 Key to set the Active Datum to 0. The tool will only measure in the direction that the initial point is measured in. See Measuring Modes – Height Section.

If a Datum is already established, then select the appropriate Measurement Mode using the Keys to the right of the Display. Any of the following measurements may be used to establish a Datum: Height, Center, Max or Min. Measure the Datum and verify that the value in the Display is the value to be used for the Datum. If the Diameter or TIR Measurement Mode is selected, it will be necessary to use the Hot Key on the Base or the F5 Key (↶) on the Display to change the Display Value to Center, Max or Min before a Datum can be stored.

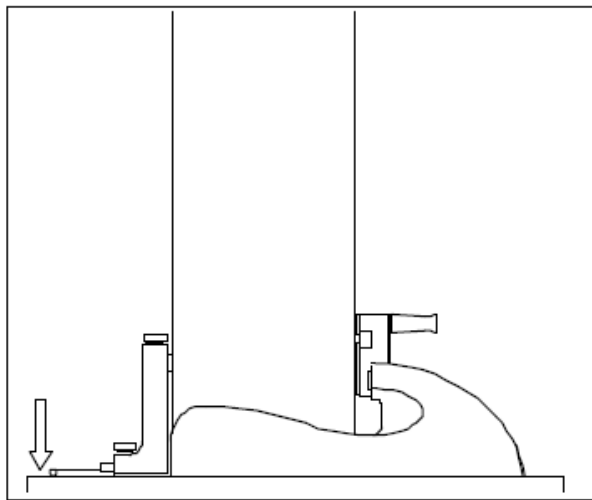

Figure 11

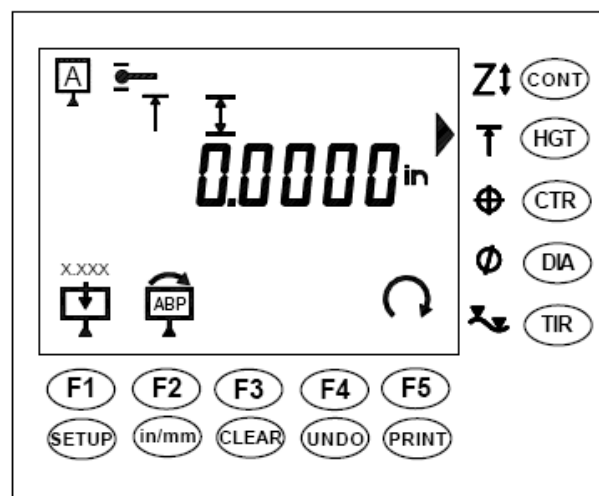



Figure 12

Store Datum - Simply press the F1 Key while displaying any of the above measurements and the Active Datum will be set to 0 at the Measured Feature.

Note: Two Datums (A and B) and a Preset (P) may be stored. The Active Datum appears as a letter (A, B or P) in the Datum Symbol in the upper left corner of the display. The Active Datum may be changed at any time by pressing the F2 Key (ABP).

Store Preset – If the Preset is active, a P will appear in the Datum Symbol in the upper left corner of the Display. When the F1 Key is pressed the Preset Value will be displayed. The Preset Value may be changed at this time using the F1 through F4 keys. After verifying that the preset value is correct press the F5 key and the Datum will be set to the Preset Value at the Measured Feature.

Measuring - Height

Height Measuring Mode : The Height Mode can be used to measure the Height of either the upper or lower surface of a part. Press the HGT Key to the right of the Display to enter this mode. The tool will request a data point (Pt 1). Using the Coarse Adjuster Knob, bring the Probe into contact with the surface to be measured until it Beeps. Move the Probe clear of the surface.

Note: If the probe has not been calibrated the Altissimo will only allow measurements in one direction, the same direction as the Datum was taken.

The display will show the Distance between the Datum and the Measured Surface. If you have measured more than one feature the Display will show a second Icon above the Measurement Value. Press the Hot Key on the Base or the F5 Key on the Display to switch the measured value between Height and Distance to Last Feature.

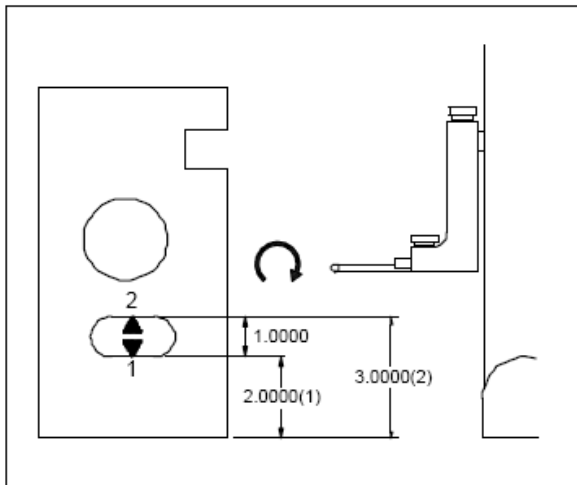

Figure 13

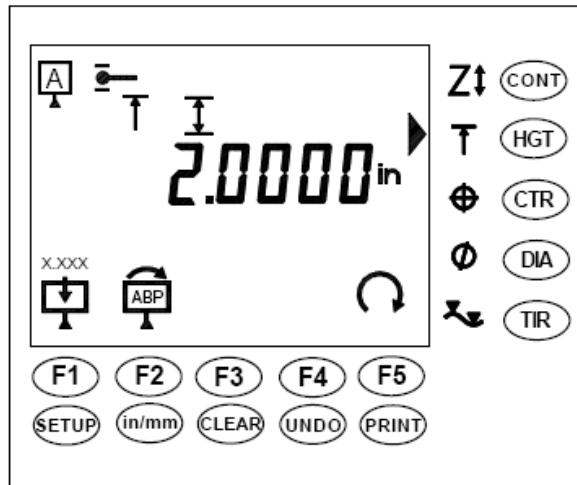



Figure 14

In Figure 13 and 14:

Point 1 is taken, the Height Value is 2.0000, the Height Icon  is flashing.

Point 2 is taken, the Height Value is 3.0000, the Height Icon  is flashing, Dist. Between Features Icon  is on. Press the HOT Key or the F5 Key to toggle between the Height and The Distance Between Features Values. The Active Value is the Icon that is Flashing.

Unidirectional Height Measuring Mode: If the probe is not calibrated, the Altissimo can be used in the Unidirectional Height Mode. When the Probe Symbol is flashing in the upper left corner of the Display, simply take a measurement in either direction, Press the F1 Key to set the Active Datum to 0. Only one "Hit" bar will be displayed with the Probe Calibration Icon. (See Figure 15) The tool will only measure in the direction that the initial point was measured in. To clear the Probe Calibration see Setup Modes – Probe Calibration Section.

Note: When the Probe is not calibrated, the Altissimo can only be used in the Height and Continuous Modes.

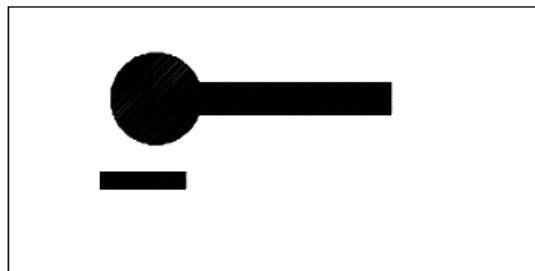

Figure 15

Measuring - Center

Center Measuring Mode \oplus : The Center Mode can be used to measure the Center of a Bore, Slot or Rib. Press the CTR Key to the right of the Display to enter this mode. After probing points on opposite sides of the Feature the Altissimo automatically calculates and displays the Center of the Feature.

The Display will request Point 1 (Pt 1). Locate the probe approximately in the center of the Feature to be measured. Using the Coarse Adjuster Knob, bring the Probe into contact with either the lower or upper surface of the Feature to be measured until the tool Beeps. The display will request a second point (Pt 2). Without moving the part or the tool, bring the Probe into contact with the opposite surface of the Feature until the tool Beeps. Move the Probe clear of the surface.

Note: If measuring a Rib it will be necessary to move the part or the tool to probe the opposite side. Care should be taken to reposition the probe as close as possible to the point opposite the first point.

The display will show the distance between the Datum and the Center of the Feature. Press the Hot Key on the Base or the F5 Key on the Display to switch the measured value between the Center and the Distance Between Last Two Points. If you have measured more than one feature the Display will show a third Icon, Distance to Last Feature.

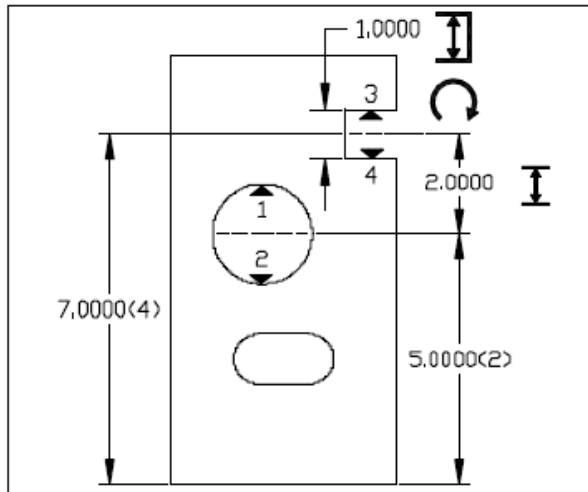

Figure 16

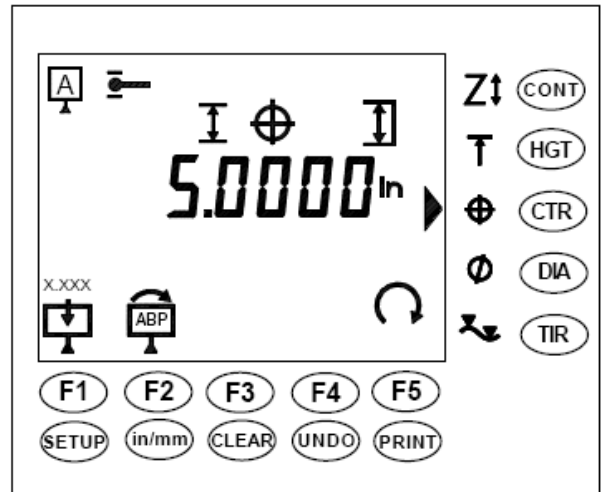

Figure 17

In Figure 16 and 17:

Point 1 is taken, the Tool requests Point 2 (Pt 2).

Point 2 is taken, the Center Value is 5.0000, the Center Icon \oplus is on, Distance Between Points Icon I is flashing.

Point 3 is taken, the Tool requests Point 2 (Pt 2).

Point 4 is taken, the Center Value is 7.0000, the Center Icon \oplus is on, the Distance Between Points Icon I and the Distance Between Feature Icon T are flashing.

Press the HOT Key to toggle between the Center, the Distance Between Points and the Distance Between Features Values. The Active Value is the Icon that is Flashing.

Note: The Distance Between Points is used to measure the Slot Width (distance between points 3 and 4). In the case of measuring a Circle (points 1 and 2) the value is meaningless since it is unlikely that the measurement will be taken in the exact center of the Hole.

Measuring - Diameter

Diameter Measuring Mode ϕ : The Diameter Mode can be used to measure a Diameter of a Shaft or Bore or the Height of a Slot or Rib. Press the DIA Key to the right of the Display to enter this mode. After scanning the upper and lower surface of the part, the Altissimo automatically calculates the Diameter.

The Display will request Scan 1 (Scn 1). Locate the probe to one side of the center of the Hole or Boss to be measured. Using the Coarse Adjuster Knob, bring the Probe close to either the lower or upper surface of the Hole to be measured. Pull out the Adjusting Knob to engage the Fine Adjust mechanism and move the probe onto the surface until the tool beeps. Slide the probe across the High or Low point of the Hole. (See Figure 18) Move the Probe clear of the surface; the tool will beep twice as the probe is retracted. The Display will request a second Scan (Scn 2).

Bring the Probe into contact with the opposite surface of the hole or slot until the tool beeps. Slide the probe across the High or Low point of the Hole. (See Figure 18) Move the Probe clear of the surface; the tool will beep twice as the probe is retracted.

The display will show the Diameter of the Hole or Boss. (See Figure 19) Press the Hot Key on the Base or the F5 Key on the Display to switch the measured value between Diameter and Center of the Hole. If you have measured more than one feature the Display will show a third Icon, Distance to Last Feature.

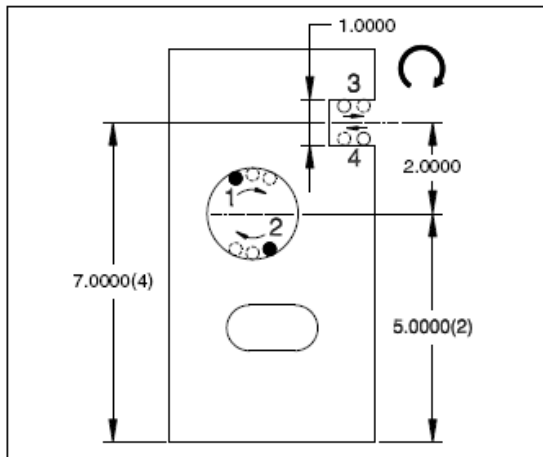

Figure 18

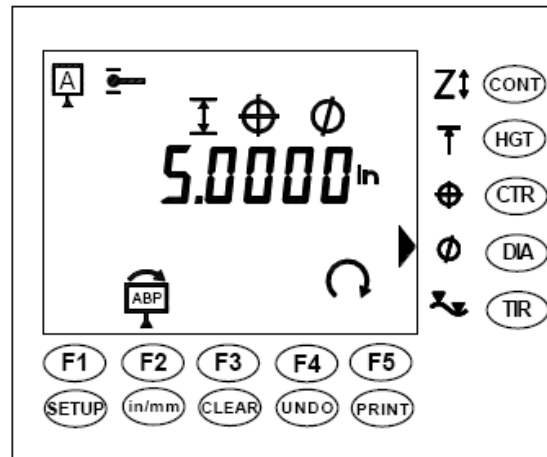

Figure 19

Note: When using the Diameter Mode to measure very small diameters where the probe cannot be swept very far past the top or bottom of a hole or boss, or to measure a slot width, it is best to end the scan by pressing the Hot Key rather than retracting the probe from the surface. This will provide the most accurate measurements.

Note: If the tool beeps three times before you end the Scan you have exceeded the High or Low Limit of the Scanning Range. (See Figure 20) Press CLEAR Key to clear the last data point and remeasure the surface. You can monitor your position within the Scanning Range by observing the Scanning Meter on the Left Side of the Display Screen.

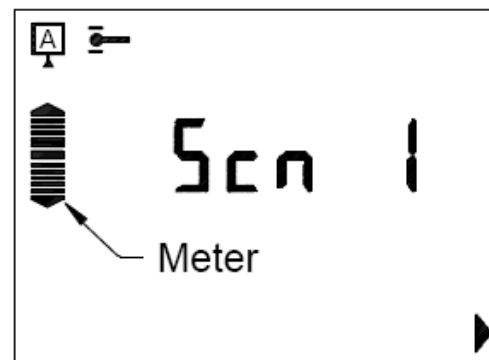

Figure 20

Tip: When Measuring Diameters it is helpful to set the Belt Locking Knob to drag a little on the belt. This will prevent the probe from moving while scanning and eliminate the need to engage the Fine Adjust Knob. Tightening the Belt Locking Knob too much will prevent the probe from moving.

Tip: For quick measurements, the probe can be brought into contact with the surface to be measured by using the Coarse Adjuster Knob. Try not to move the Knob while scanning the surface. After scanning the surface use the Knob to retract the probe. This will provide slightly reduced accuracy but greatly speed up measurements.

Measuring - TIR

TIR: The TIR mode can be used to measure TIR of either the upper or lower surface of a part. Press the TIR Key to the right of the Display to enter this mode.

The Display will request Scan 1 (Scn 1). Using the Coarse Adjuster Knob, bring the Probe close to the Surface to be measured. Pull out the Adjusting Knob to engage the Fine Adjust mechanism and move the probe onto the surface until the tool beeps. Slide the probe across the High or Low point of the Hole. Press the Hot Key to end the scan.

The display will show the TIR of the measured Surface. Press the Hot Key on the Base or the F5 Key on the Display to switch the measured value between TIR, MAX and MIN. (See Figure 22) MAX is the distance from the Active Datum to the Point furthest away. Min is the Distance from the Active Datum to the point closest. When either the MAX or MIN are selected using the Hot Key, the F1 Key will allow setting the Active Datum to either feature.

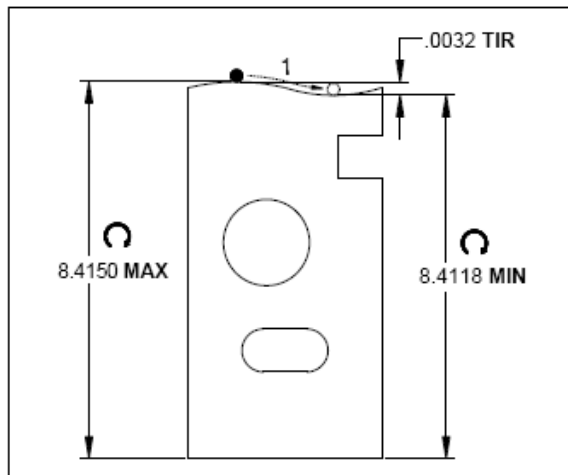

Figure 21

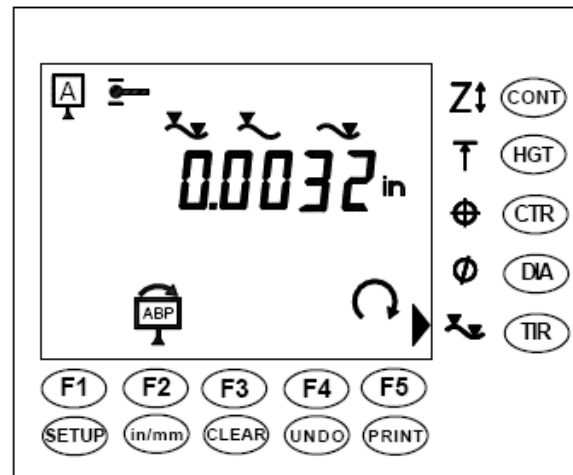

Figure 22

Tip: When Measuring Surfaces it is helpful to set the Belt Locking Knob to drag a little on the belt. This will prevent the probe from moving while scanning and eliminate the need to engage the Fine Adjust Knob.

Note: Retracting the probe from the surface will terminate the Scan, however, the most accurate results will be achieved when the Hot Key is used to terminate the scan.

Tip: The TIR mode can be used to measure the high or low point of a Diameter or other surface. The Datum can then be set to the Max or Min Value. (See Figure 21)

Note: If the tool beeps three times before you end the Scan you have exceeded the High or Low Limit of the Scanning Range. (See Figure 23) Remeasure the surface. You can monitor your position within the Scanning Range by observing the Scanning Meter on the Left Side of the Display Screen.

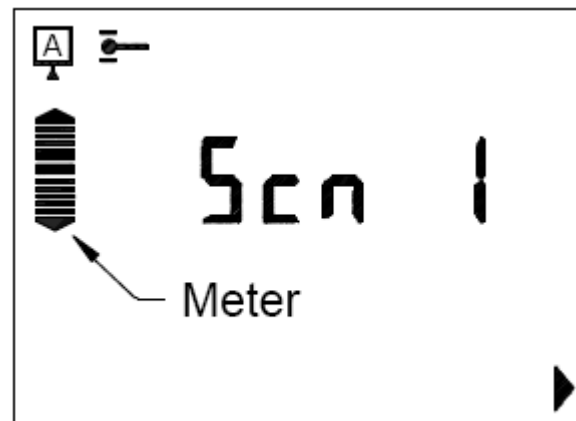

Figure 23

Tip: For quick measurements, the probe can be brought into contact with the surface to be measured by using the Coarse Adjuster Knob. Try not to move the Knob while scanning the surface. After scanning the surface use the Knob to retract the probe. This will provide slightly reduced accuracy but greatly speed up measurements.

Continuous Display and Scribing

Continuous Display: The Continuous Display Mode is normally used for Scribing. It can also be used to measure features such as the centers of holes in sheet metal using a Conical Probe. Press the CONT Key to the right of the Display to enter this mode.

The Display provides a reading of the current probe position. Lock the Probe Locking Knob and install the Scriber, being careful to make the bottom of the scriber parallel to the Surface Plate. (See Figure 24) Using the Coarse Adjustment Knob bring the Scriber lightly in contact with the Surface Plate. Press the F1 key to set the Active Datum to 0 on the Surface Plate (or any other reference surface). (See Figure 25)

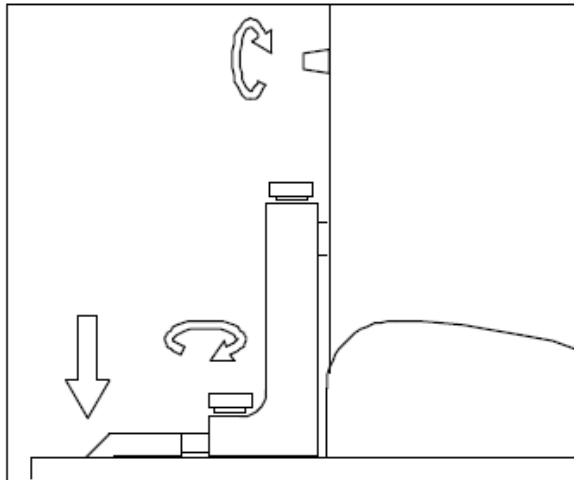

Figure 24

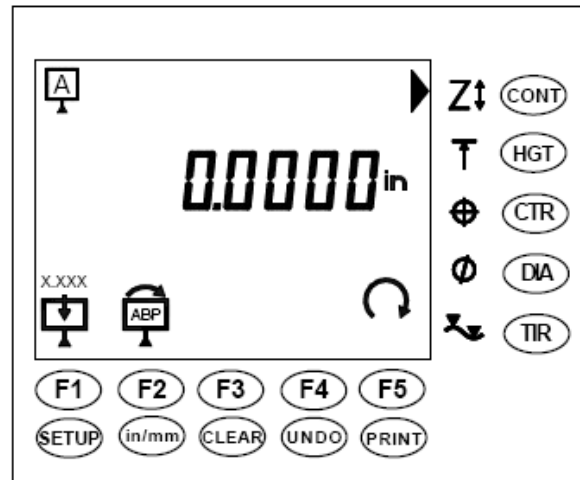

Figure 25

Move the Scriber close to the desired height using the Coarse Adjustment Knob. Pull out the Knob to engage the Fine Adjustment Mechanism and adjust the scriber to the desired height. (See Figure 26) Tighten the Belt Locking Knob and Scribe the Surface. (See Figure 27)

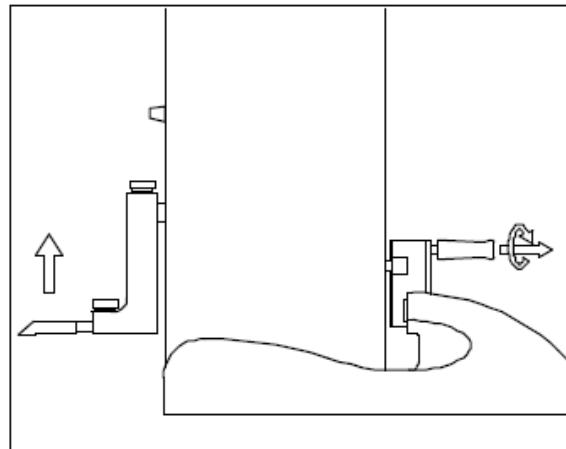

Figure 26

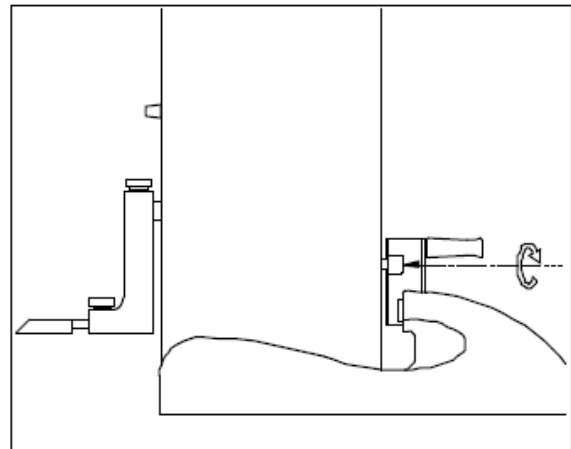

Figure 27

Note: If the tool beeps while scribing then make sure you have locked the Probe Locking Knob.

Setup Mode

Setup: The Setup Mode is used to perform functions such as:

- Probe Diameter Calibration
- Setting Probe Force
- Changing Display Resolution
- Adjusting Beeper Volume
- Setting the Printer to Continuous Mode.

Press the Setup Key to step through the functions. When the desired function is activated use the function keys to change the settings and the F5 Key to accept the changes.

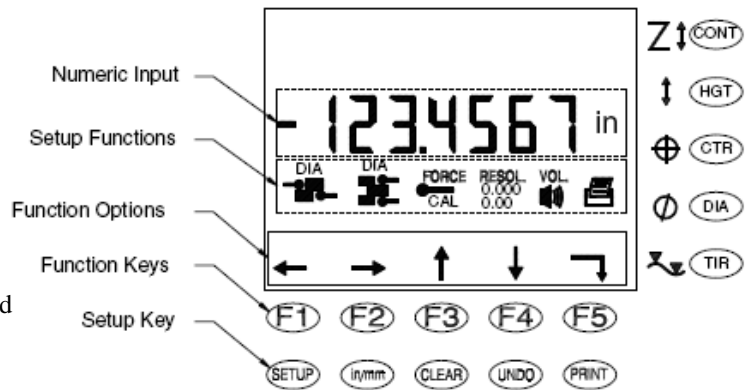

Probe Diameter Calibration: This is the normal mode for calibrating the probe diameter using the Calibration Block supplied with the tool. If the Probe Symbol is Flashing in the upper left corner of the Display, it will be necessary to Calibrate the Probe Diameter.

Important: The Altissimo will store the Calibrated Probe Diameter even after it is turned off. The Probe Diameter must be recalibrated when the Altissimo is first received and periodically thereafter, especially when measuring conditions change or the Probe is changed or repositioned.

Press the SETUP Key and the Probe Calibration Mode Icon will light. The Display will prompt for Point 1 (Cal 1). Position the Calibration Block under the Probe. Using the Coarse Adjuster Knob move the probe down onto the Upper Measuring Surface until the tool beeps. Move the Probe clear of the surface. The display prompts for Point 2 (Cal 2). Similarly measure the Lower Measuring Surface of the Calibration Block. Measure the Upper and Lower Measuring Surface a second time.

Note: The first and second measurements must be taken in opposite directions, the third and fourth measurements must also be taken in opposite directions. (See Figure 28) If the display does not increment from Cal 3 to Cal 4, then take the next Point must be taken in the opposite direction.

Accept the Calibration - After measuring each surface twice, the Altissimo will display a number which is the Deviation of the Probe Calibration. The deviation is the repeatability of the points taken during Probe Calibration. This provides a measure of the quality of the measurements. If the Deviation is sufficiently low, under .0002" (.004mm), then Press the F5 Key (↵) to accept the value. (See Figure 29) If the Deviation is high, over .0002" (.004mm), then check the tightness of the Probe Arm and Probe. Check the cleanliness of the Probe Tip and Calibration Block. Make sure that the Probe and Belt Locks are fully unlocked. Then recalibrate the Probe.

Clearing Probe Calibration: Pressing the CLEAR key while the Probe Calibration Symbol is on will clear the Probe Calibration.

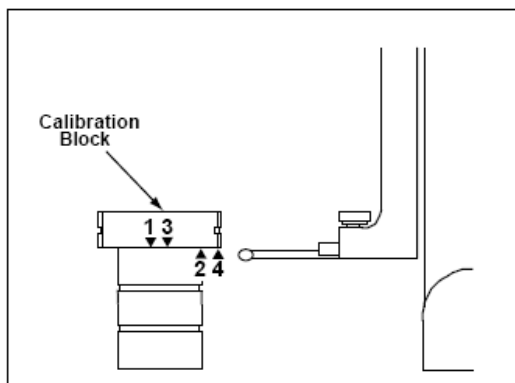

Figure 28

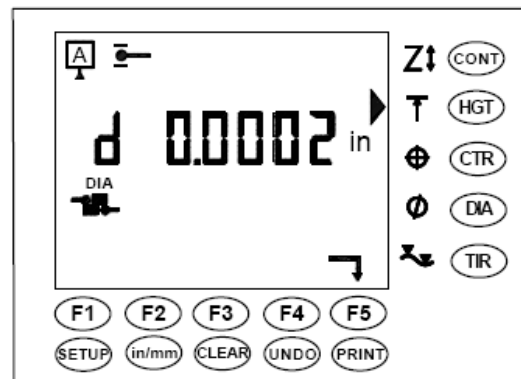

Figure 29

Setup Mode (Cont.)

Probe Diameter Calibration (Preset): This is the alternate mode for calibrating the probe diameter using a Calibration Block with a known Block Size such as a Gage Block. This could be either an ID or OD Measurement.

Press the SETUP Key twice and the Probe Calibration Mode Icon will light. A Preset Value will be displayed. If the value is correct Press Undo and begin measuring. If the value is 0 or not correct use the F1 - F4 keys to adjust the Preset and Press the F5 key (↵) to accept the Value.

Position the Calibration Block under the Probe. Using the Coarse Adjuster Knob move the probe down onto the Upper Measuring Surface until the tool beeps. Move the Probe clear of the surface. The display will indicate the first point is taken and request a second point. Similarly measure the Lower Measuring Surface of the Calibration Block. Measure the Upper and Lower Measuring Surface a second time.

Note: The first and second measurements must be taken in opposite directions and the third and fourth measurements must also be taken in opposite directions. Best results will be achieved when the points are taken on the upper and lower surface alternately. (See Figure 30)

Accept the Calibration - After measuring each surface twice, the Altissimo will display a number which is the Deviation of the Probe Calibration. The deviation is the repeatability of the points taken during Probe Calibration. This provides a measure of the quality of the measurements. If the Deviation is sufficiently low, under .0002" (.004 mm), then Press the F5 Key (↵) to accept the value. (See Figure 31)

Note: If the Deviation is high, over .0002" (.004 mm), then check the tightness of the Probe Arm and Probe. Check the cleanliness of the Probe Tip and Calibration Block. Make sure that the Probe and Belt Locks are fully unlocked. Then recalibrate the Probe.

Important: The Altissimo will store the Calibrated Probe Diameter even after it is turned off. The probe must be recalibrated each time it is changed or repositioned.

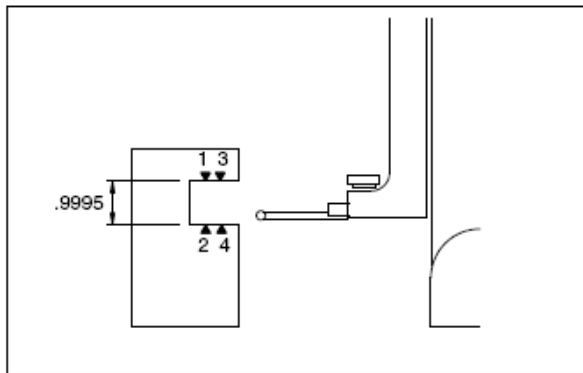

Figure 30

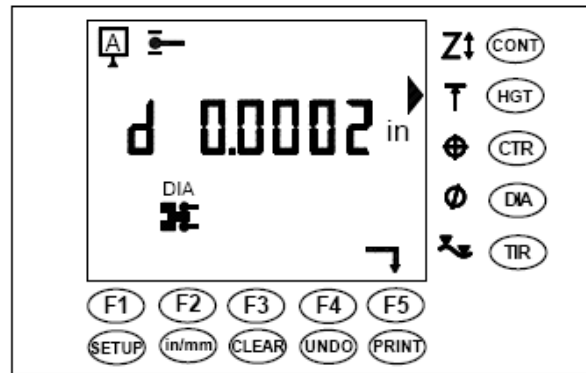

Figure 31

Setup Mode (Cont.)

Probe Force Setting: The Probe Force Mode is used to change the Measuring Force. The default Probe Force Value of 1 is Calibrated at the factory to 4oz (1.1 Newton). The tool will measure between approximately 3.5 and 8 oz (1 and 2.2 Newton)

Press the SETUP Key three times and the Probe Force Icon will light and a Probe Force Value between 0 and 9 will be displayed. (See Figure 32) Use the F1- F4 keys to adjust the Probe Force Value and press the F5 key (↵) to accept the Value, each unit is approximately 0.5oz (0.14 Newton). The Force Icon will appear above the Probe Calibration Icon in the Upper left corner of the Display.

Note: To reset the Probe Force to the Calibrated Value, press the Clear key while in the Probe Force Mode, the display will reset to 1, press the F5 Key to accept the value. The Probe Force Icon will go out.

Display Resolution: The Display Resolution Mode is used to adjust the Display Resolution between 0.0001", 0.0005" and 0.001" (0.002 mm, 0.010 mm and 0.02 mm). The default is 0.0001".

Press the Setup Key four times and the Resolution Icon will light. (See Figure 33) Use the F3-F4 Keys to change the resolution and press the F5 Key to accept the resolution.

Note: To reset the Display Resolution to the default value, press the Clear Key while in the Display Resolution Mode, the display will reset to .0001" (.002 mm), press the F5 Key (↵) to accept the resolution.

Beeper Volume: The Beeper Volume Mode is used to adjust the Beeper volume for use in various noise environments.

Press the Setup Key five times and the Beeper Volume Icon will light and a Value between 0 and 9 will be displayed. (See figure 34) Use the F3-F4 Keys to increase or decrease the volume and press the F5 Key to accept the value. Each time the value is changed the Tool will beep at the set volume.

Note: To reset the Beeper Volume to the default level, press the Clear Key while in the Display Resolution Mode, the display will reset to 3. Then press the F5 Key (↵) to accept the volume.

Printer: The Printer Mode is used to set the Serial Data Output to transmit continuously whenever a new feature is measured or other function is completed.

Press the Setup Key six times and the Printer Icon will light and a value will be displayed. (See Figure 35) To turn the printer on continuously press the F3 Key (↑) to set the value to 1, to turn the printer off press the F4 Key (↓) to set the value to 0. Then press the F5 Key (↵) to accept the volume. If the Printer is set to print continuously the Printer Icon will stay lit after the F5 Key (↵) is pressed.

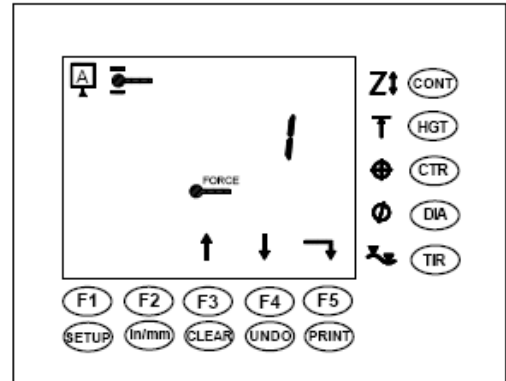

Figure 32

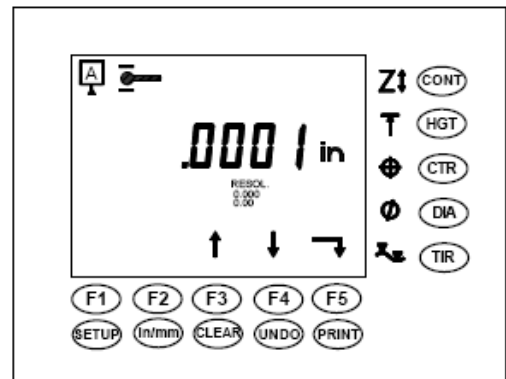

Figure 33

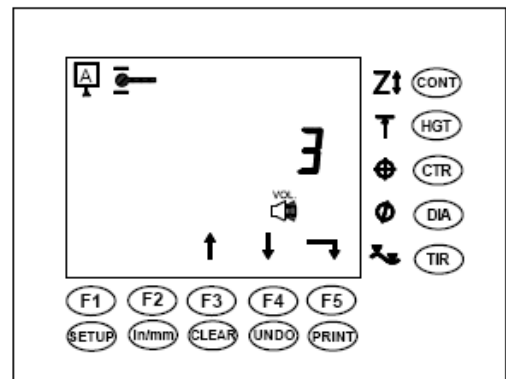

Figure 34

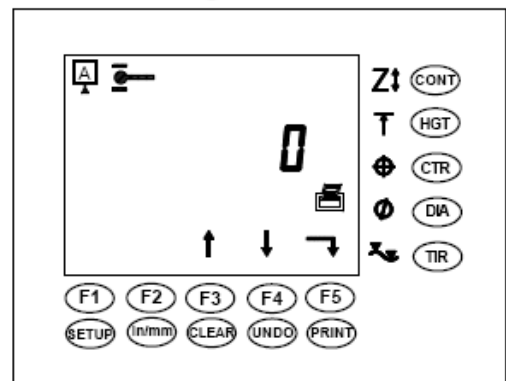













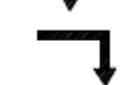

Figure 35

Symbols

<u>Status</u>	<u>Description</u>
	Datum - Indicates if Active Datum is Established (Continuous) or Not Established (Flashing)
	Probe Calibration - Indicates if Probe Diameter is Calibrated (Continuous) or Not Calibrated (Flashing)
	Hit Indicators – Bars above and below Probe Calibration, which indicates when points are taken (Continuous) or can be taken (Flashing).
	Probe Force - Indicates that Probe Force Level is changed from Calibration Force.
	Battery Low - Indicates Low Battery Level (Plug in Charger).
<u>Measurement</u>	<u>Description</u>
	Height - Display is Height Measurement
	Distance Between Features - Display is Distance between the last two features measured
	Center – Display is Distance from Active Datum to Center
	Diameter – Display is Diameter
	Distance Between Points – Display is Distance Between the points used to measure the feature.
	TIR – Display is the TIR (Total Indicated Reading) or Max – Min Point
	MAX – Display is Max value of scanned surface
	MIN – Display is Min value of scanned surface

Symbols (Cont.)

Setup Mode	Description
	Normal Probe Calibration Mode – Allows for Probe Calibration with standard Calibration Setting Block supplied with tool.
	Preset Probe Calibration Mode - Allows for Probe Calibration with a Fixed Size Calibration Setting Block.
	Probe Force Setting Mode – Allows adjustment of Probing Force between 0 and 9. Default value is 1, which is the Calibrated Force Level of 4 oz. (Range is approximately 3.5 – 8.0 oz, by 0.5 oz)
	Display Resolution Mode – Allows Display resolution to be adjusted between 0.0001”, 0.0005” and 0.001” (0.002 mm, 0.010 mm and 0.020 mm)
	Beeper Volume Mode – Allows adjustment of Beeper Volume between 0 and 9.
	Printer On/Off Mode – Allows printer to be turned on continuously. Icon stays on if Printer is on continuously.
Function Key	Description
	Set Datum – Allows Datum (Zero) to be set to Displayed Value.
	Select Datum – Allows changing between Datum A and B and Preset P
	Hot Key – Allows switching between Measurement Options. Duplicates function of Hot Key mounted in Base.
	Move Left – Move Flashing Digit to Left in Preset Mode
	Move Right – Move Flashing Digit Right in Preset Mode
	Increase – Increase value
	Decrease – Decrease Value
	Enter – Enter or Accept Value

Specifications

Range of Measurement

Standard Probe and Probe Arm	0 – 24" (0 – 610 mm)
Application range (Probe arm inverted)	6 – 30" (150 – 760 mm)

Accuracy

Best performance can be achieved while taking measurements at a constant temperature of 68° (20°C) in a **non-condensing environment**.

± .0003" (.008 mm) @ 68° F (20° C) with Standard Probe and Probe Arm

Repeatability (2s)

.0002" (.004 mm)

Resolution (Adjustable)

.0001" (.001 mm) - Normal
.0005" (.010 mm) - Reduced
.001" (.020 mm) - Reduced

Measuring System

Starrett Capacitive System

Display

LCD with .5" (12.5mm) high Digits

Maximum Measuring Speed

24"/sec (.6 m/sec)

Probe Measuring Force (Adjustable)

Calibrated to 4oz (1.1 Newton)
Electronically adjustable from ~3.5 to ~8 oz (1.0 to 2.2 Newton)

Dimensions

Length 11", Width 7 3/4", Height 36 1/2" (280 mm x 197 mm x 927 mm)

Weight

40 lb. (18.2 kg)

Power Supply

9VDC 600mA 
US: 120V~ 60Hz 12W Adapter/Charger
EU: 230V~ 50Hz 17.5W Adapter/Charger

Battery Pack

NiMH Rechargeable Battery Pack, 6 V DC, 100+ hours of operation between charges, 10 - 16 hour charge time

Temperature Range

Operation: +10°C to +40°C
Storage: -10°C to +60°C

Humidity Range

0 - 80% non-condensing

Standard Accessories

.1875"/4.8mm Dia. Carbide Probe, Probe Holder, AC charger/adaptor, Probe Calibration Block

Care and Maintenance

Caution:

- Use of this gage other than specified by the manufacturer is not recommended.
- Use only Starrett replacement Battery Pack and Charger. Follow the charging conditions we specify.
- Do not short-circuit the battery pack or disassemble the battery pack. This is dangerous and may cause heat generation or fluid leakage.
- Do not throw the battery into a fire or heat excessively.
- Charge the batteries between 32 and 104°F (0 and 40°C). Charging the battery outside this range may cause the batteries to leak, generate heat and shorten the service life of the batteries.
- Store the batteries between 32 and 104° F (0 and 40°C). Storing the batteries outside this range may shorten the service life of the batteries.
- If the battery pack leaks fluids, changes shape, changes color or changes in any other form then discontinue use.
- If the Battery Pack fails to charge in the prescribed period of time, do not recharge. The batteries could leak and damage the gage. Replace the battery. Only use Starrett replacement battery pack.
- If fluid from the battery comes in contact with the skin, wash the area immediately with clean water. Battery fluid can injure the skin.
- If fluid from the battery comes in contact with the eyes, wash them immediately with clean water (do not rub). Battery fluid in the eyes can cause loss of sight.
- Do not use this gage where it will be directly exposed to cutting fluids, water, dust, etc.
- Do not use this gage where it will be exposed to direct sunlight, or drafts of hot or cold air.

Battery Charging - Battery charging automatically shuts off after a predetermined time determined by the battery level. If the Low Battery ICON is displayed this time will be fourteen hours. The tool may be used while charging and may be left connected to the charger if desired. (Figure 36) The Charge circuit will maintain a charge after the battery is fully charged without damaging the battery.

Installation Category - The Altissimo is an Installation Category II device.

Important: If the Gage will not be used for an extended period of time, remove the batteries. This will prevent the possibility of a leaking battery damaging the case.

Replacing Batteries - The Altissimo uses advanced NiMH Batteries, which should last many hundreds of recharge cycles. If the batteries need to be replaced make sure all power is off by unplugging the AC Adapter and switching the On/Off switch to the 0 position. Remove Data Output Cable. Remove the front cover of the electronics enclosure by unscrewing the 3 Phillips head screws located at the rear of the Display. (See Figure 37)

Carefully remove the Front Cover and disconnect the Ground Cable, Battery Cable and Display Cable from the PC Board. (See Figure 38) Place the Display in a safe place. The battery pack is mounted with Velcro, Carefully pull the battery pack free and noting the orientation of the cable push the new Battery Pack firmly in place Carefully reconnect the Display Cable, Battery Cable and Ground Cable to the PC Board. Screw the Front Cover back into place. Be careful not to over tighten the screws.

Note: The Battery Charger must be inserted after replacing the batteries in order to reinitialize the tool even if the battery pack is fully charged.

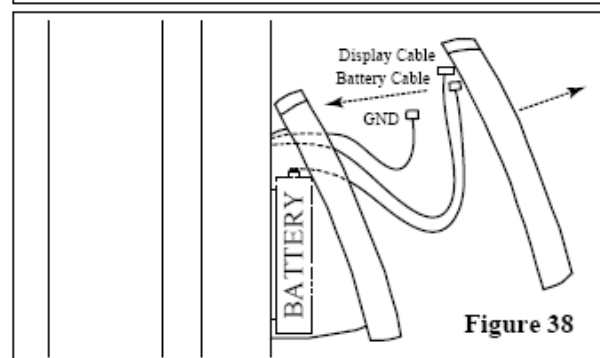
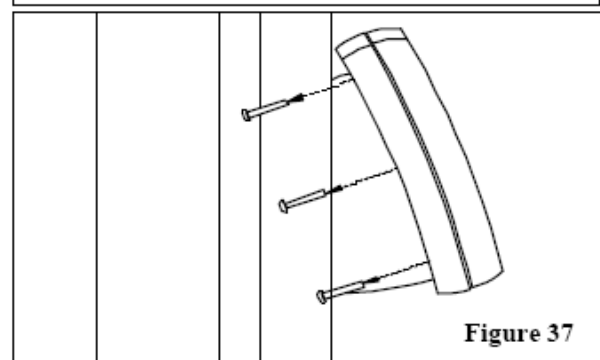
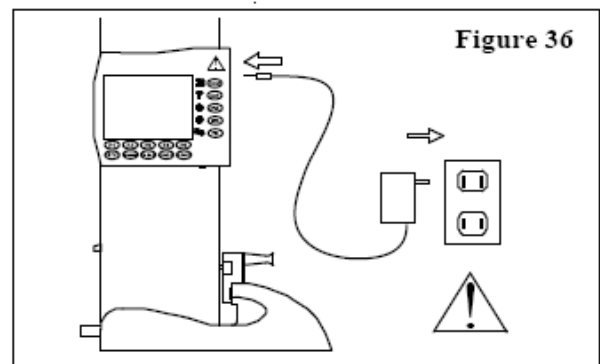

Care and Maintenance

Cleaning of the Glass Scale and Guide Ways:

Remove Top Cover – Use 3/16" (4.78 mm) Allen Wrench to remove the top Cover. (See Figure 39)

Important: Cleaning the Glass Scale is a delicate operation, therefore use extreme care.

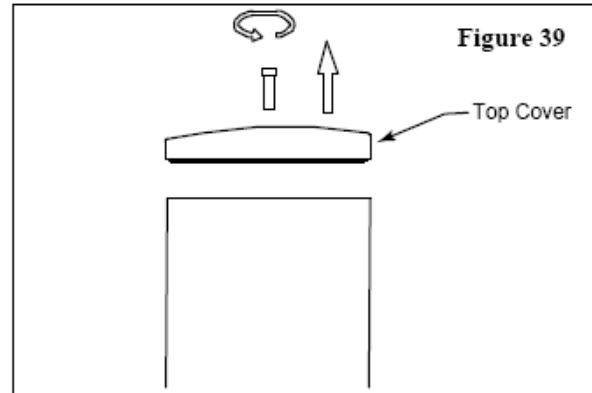

Disconnect Cables – Disconnect the Display Cable and the Ground Cable. (See Figure 40)

Remove Belt Lock Knob – Unscrew Belt Lock Knob and remove. (See Figure 40)

Remove Outer Casing – Carefully lift the Outer casing off towards the top of the tool in a straight line. Avoid contact with any parts inside. (See Figure 40)

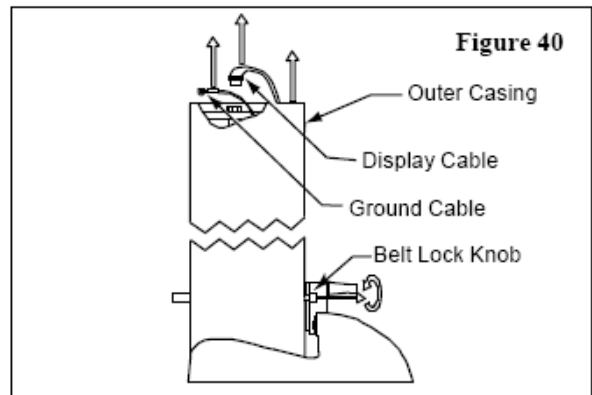

Clean Glass Scale – Carefully clean the Glass Scale with a soft lint free cloth lightly dampened with Isopropyl Alcohol. Next, coat the Scale by applying a greaseless lubricant such as LPS[®] 1† by saturating a lint-free cloth then wiping it onto the surface of the glass and letting it dry. (See Figure 41)

Clean Slide Bearing Tracks and Slide Bearings – Carefully clean the 3 Slide Bearing Tracks and 3 Slide Bearings outside diameter with a soft cloth or cotton swab lightly dampened with Isopropyl Alcohol. (See Figure 42)

Clean Guide ways – Carefully clean the guide ways and 8 guide way bearings located along both sides of the column with a soft cloth lightly dampened with Isopropyl Alcohol. (See Figure 42)

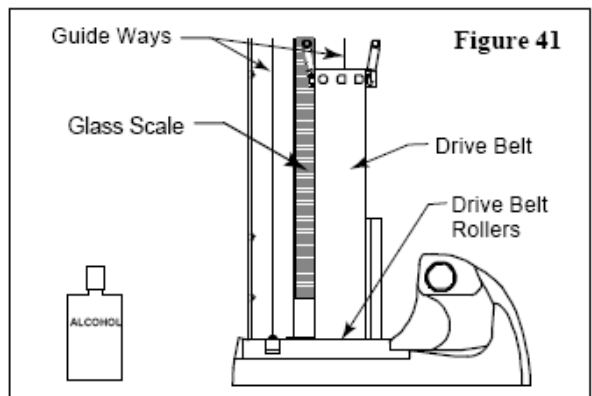

Clean Drive Belt and Rollers – Carefully clean the 2 Rollers located at the top and 2 Rollers located at the bottom of the column with a soft cloth lightly dampened with Isopropyl Alcohol. Clean the side of the Drive Belt that comes in contact with the rollers.

Replace the Cover – Reconnect the Display and Ground Cables and replace the Top Cover. Be careful not to over tighten the screws.

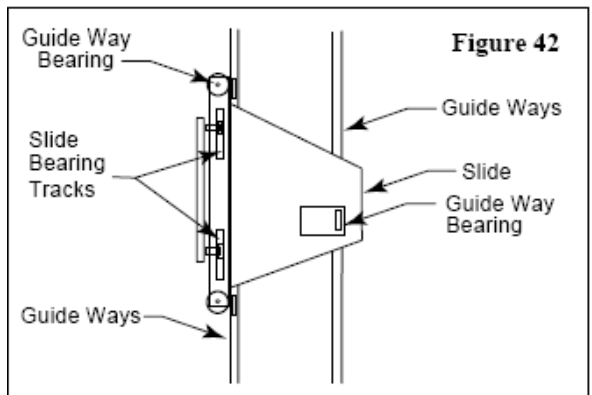

† © 1997 LPS[®] is a registered trademark of LPS Laboratories, Inc.

Troubleshooting

Error Messages:

E01 – This message usually results from an over speed condition. If this message appears on display, turn the power off, wait 5 seconds and turn the power on again. Pressing the UNDO key and then the CLEAR Key may also clear the error. If this fails to clear the error condition then it may be necessary to perform maintenance on the tool. See Maintenance Section.

Probe Calibration

Deviation is high - If the Deviation is over .0002" (.004 mm), then check the tightness of the Probe Arm and Probe. Check the cleanliness of the Probe Tip and Calibration Block. Make sure that the Probe and Belt Locks are fully unlocked. Then recalibrate the Probe.

Inaccurate Measurements

Poor measurement repeatability - Check the tightness of the Probe Arm and Probe. Make sure that the Probe and Belt Locks are fully unlocked. Then recalibrate the Probe and reestablish the Datum. Inaccurate Measurement - Check to see that the proper Datum is selected.

Icons Flashing

If the Probe Icon in the upper left corner of the display is flashing the Probe needs to be calibrated. If the Datum Icon in the upper left corner is flashing a Datum needs to be established.

Icons Light

If the word "FORCE" appears above the Probe Icon in the upper left corner of the display it indicates that the Probing Force is set at a value other than the Calibrated Value. See Probe Force Setting in the Setup Mode Section.

If the battery symbol lights in the upper right corner the batteries should be recharged. See Battery Charging in Care and Maintenance Section.

Accessories and Replacement Order Information

Description	Catalog No.	EDP No.
Height Gage	2000-24	67008
Ø .1875" (4.8 mm) Carbide Probe (Standard)	PT27937	67009
Probe Holder (Standard)	PT27940	67010
Probe Calibration Block (Standard)	PT27944	67011
Accessory Set (Includes)	S2000AZ	66997
1. Probe Tip, 5 Way Adapter w/Shank	PT27948	67012
2. Ø.040" (1 mm) Carbide Contact Point	PT23942	65255
3. Ø.078" (2 mm) Carbide Contact Point	PT23914	64222
4. Ø.120" (3 mm) Carbide Contact Point	PT23943	65256
5. Contact Wrench	PT27952	67013
6. Ø.400" (10.2 mm) Cylindrical Probe	PT27945	67014
7. Round Carbide Scriber	PT27950	67015
8. Depth Gage Attachment	PT27949	67016
9. Holder for Dovetail Indicators	PT27946	67017
Replacement Battery Pack, NiMH 6V	PT62011	67018
Charger/Power Supply for USA and Canada	PT62015	67002
Charger/Power Supply for United Kingdom Configuration	PT62130	67003
Charger/Power Supply for European Configuration	PT62131	67004
Interface Adapter for Starrett Tools to IBM-PC or Compatible	PT61768	66454
Shielded Cable to Starrett Nos. 761/772 Series Starrett Modules, No.768 Remote Display and No. PT61768 Adapter	PT62103	67019

Free Manuals Download Website

<http://myh66.com>

<http://usermanuals.us>

<http://www.somanuals.com>

<http://www.4manuals.cc>

<http://www.manual-lib.com>

<http://www.404manual.com>

<http://www.luxmanual.com>

<http://aubethermostatmanual.com>

Golf course search by state

<http://golfingnear.com>

Email search by domain

<http://emailbydomain.com>

Auto manuals search

<http://auto.somanuals.com>

TV manuals search

<http://tv.somanuals.com>