

INSTALLATION AND MAINTENANCE INSTRUCTIONS

B110RLP Plug-in Detector Base

For use with the following smoke detectors:

In US :	1151, 2151
In Canada:	1151A, 2151A
In Europe:	1151E, 2151E



156-0596-0051R

3825 Ohio Avenue, St. Charles, Illinois 60174
1-800-SENSOR2, FAX: 630-377-6495
www.systemsensor.com

SPECIFICATIONS

Base Diameter:	6.2 inches (157 mm)
Base Height:	0.95 inches (24 mm)
Weight:	0.3 lb. (130 g)
Mounting:	4-inch square box with or without plaster ring. Min. Depth-1.5 inches 4-inch octagon box. Min. Depth-1.5 inches 3-1/2 inch octagon box. Min. Depth-1.5 inches
Operating Temperature Range:	0° to +49°C (32° to 120°F)
Operating Humidity Range:	10% to 93% Relative Humidity
Electrical Ratings — includes base and detector	
System Voltage:	24 VDC
Maximum Ripple Voltage:	4 Volts peak to peak
Start-up Capacitance:	0.02 µF Maximum
Standby Ratings:	17 VDC Minimum; 32 VDC Maximum 120 µA Maximum
Alarm Ratings:	10 mA Minimum at 10.5 VDC; 62 mA Maximum at 32 VDC (If used, the RA400 remote lamp operates within specified detector alarm currents.)
Maximum Alarm Impedance:	1050Ω
Minimum Alarm Impedance:	516Ω
Reset Voltage:	2.50 VDC Minimum
Reset Time:	0.3 Seconds Maximum
Start-up Time:	34.0 Seconds Maximum

BEFORE INSTALLING

Please read thoroughly System Sensor's *Applications Guide for System Smoke Detectors* (SPAG91), which provides detailed information on detector spacing, placement, zoning, wiring, and special applications. This is available online from System Sensor's website: www.systemsensor.com. (For installations in Canada, please refer to CAN4-S524, *Standard for the Installation of Fire Alarm Systems*, and CEC Part 1, Sec. 32.)

NOTICE: This manual should be left with the owner/user of this equipment.

IMPORTANT: The detector used with this base must be tested and maintained regularly following NFPA 72 requirements. The detector used with this base should be cleaned at least once a year.

GENERAL DESCRIPTION

The B110RLP plug-in detector base is used with System Sensor model 1151 and 1151A ionization detector heads and model 2151 and 2151A photoelectric detector heads. The capability of plugging these detectors into a variety of special bases makes them more versatile than equivalent direct-wired models. Refer to the System Sensor catalog for other available plug-in detector bases.

This base is intended for use in 2-wire systems, with screw terminals provided for power, ground, and remote annunciator connections. The base also contains a resistor to provide current limiting in the alarm state.

MOUNTING

This detector base mounts directly to 3-1/2-inch and 4-inch octagon boxes, and 4-inch square boxes (with or without plaster rings). To mount, remove decorative ring by turning it in either direction to unhook the snaps, then separate the ring from the base. Install the base to the box using the screws supplied with the junction box and the appropriate mounting slots in the base. Place decorative ring onto base, then turn in either direction until the ring snaps in place (see Figure 1).

INSTALLATION GUIDELINES

All wiring must be installed in compliance with the National Electrical Code and the local codes having jurisdiction. Proper wire gauges should be used. The conductors used to connect smoke detectors to control panels and accessory devices should be color-coded to reduce the likelihood of wiring errors. Improper connections can prevent a system from responding properly in the event of a fire.

FIGURE 1. MOUNTING BASE TO BOX:

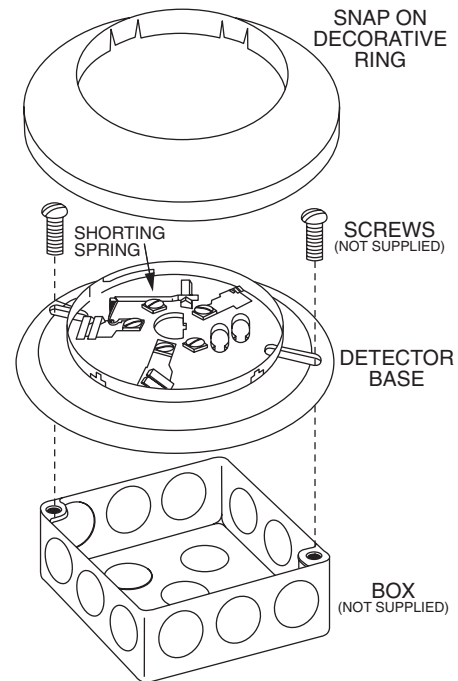

C503-00

For signal wiring (the wiring between interconnected detectors), it is recommended that the wire be no smaller than 18 gauge (1.0 square mm). Wire sizes up to 12 gauge wire (2.5 square mm) may be used with the base. For best system performance, the power (+) and (-) loop wires should be twisted pair and installed in separate grounded conduit to protect the loop from extraneous electrical interference.

Smoke detectors and alarm system control panels have specifications for allowable loop resistance. Consult the control panel manufacturer's specifications for the total loop resistance allowed for the particular model control panel being used before wiring the detector loops.

CAUTION

For system supervision — For terminals 2, 3, and 5 do not use looped wire under terminals. Break wire run to provide system supervision of connections.

Wire connections are made by simply stripping insulation from the end of the wire, sliding the bare end of the wire under the clamping plate, and tightening the clamping plate screw. Use the strip gauge molded into the base for ease of wiring to terminals 1 through 5.

System Sensor smoke detectors and mounting bases are marked with a compatibility identifier located as the last digit of a five digit code stamped on the back of the product. Connect detectors/mounting bases only to compatible control units as indicated in System Sensor's compatibility chart which contains a current list of UL listed control units and detector head/base combinations. A copy of this list is available from System Sensor upon request.

The zone wiring of the detector base should be checked before the detector heads are installed in them. To make this possible, this base contains a special spring-type shorting jumper. After a detector base is properly wired and mounted on an electrical box, make sure that the jumper spring is in contact with the base of Terminal 3. This temporary connection shorts the negative-in and negative-out leads and permits the wiring of the loop to be checked for continuity.

Once all the detector bases have been wired and mounted, and the loop wiring has been checked, the detector heads may be installed in the bases. The shorting spring in the base will disengage automatically when the detector head is removed from the base. DO NOT remove the shorting spring since it reengages as the detector head is turned into the base, completing the circuit.

TAMPER-RESISTANCE FEATURE

NOTE: Do not use the tamper-resistance feature if the XR2 removal tool is to be used.

The tamper-resistant tab, in the detector mounting bracket, can make the detector tamper-resistant by making it necessary to use a small screwdriver or similar tool to detach the detector from the bracket.

To make the detector tamper-resistant, use needle-nose pliers to break the smaller tab at the scribed line on the tamper-resistance tab. Figure 3A shows the location of this tab on the detector mounting bracket.

To remove a detector from the bracket after it has been made tamper resistant, use a small screwdriver or other similar tool, to depress the tamper-resistance tab in the slot on the mounting bracket, and rotate the detector counterclockwise (see Figure 3B).

NOTE: The decorative ring must be removed before the smoke detector can be detached from the base after the tamper-resistant capability is enabled.

FIGURE 2. TYPICAL WIRING DIAGRAM FOR 2-WIRE DETECTOR SYSTEMS:

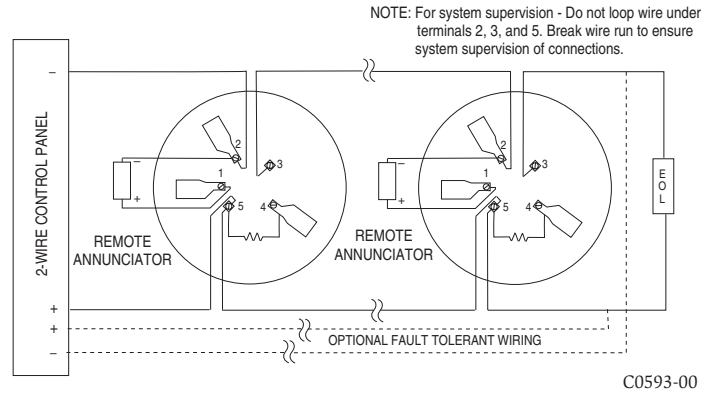

FIGURE 3A. ACTIVATING THE TAMPER-RESISTANCE FEATURE:

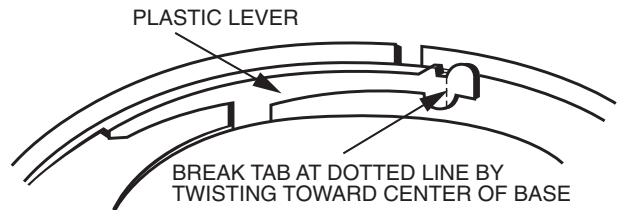
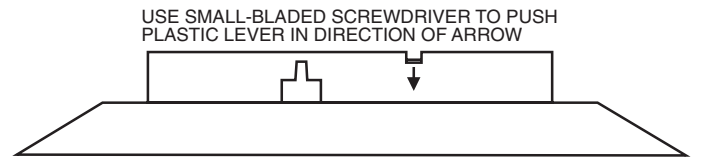

FIGURE 3B. REMOVING DETECTOR HEAD FROM BASE:



C0130-00

C0130-00

Please refer to insert for the Limitations of Fire Alarm Systems

THREE-YEAR LIMITED WARRANTY

System Sensor warrants its enclosed smoke detector base to be free from defects in materials and workmanship under normal use and service for a period of three years from date of manufacture. System Sensor makes no other express warranty for this smoke detector base. No agent, representative, dealer, or employee of the Company has the authority to increase or alter the obligations or limitations of this Warranty. The Company's obligation of this Warranty shall be limited to the repair or replacement of any part of the smoke detector base which is found to be defective in materials or workmanship under normal use and service during the three year period commencing with the date of manufacture. After phoning System Sensor's toll free number 800-SENSOR2 (736-7672) for a Return Authorization number, send defective units postage prepaid to: Honeywell,

12220 Rojas Drive, Suite 700, El Paso TX 79936, USA. Please include a note describing the malfunction and suspected cause of failure. The Company shall not be obligated to repair or replace units which are found to be defective because of damage, unreasonable use, modifications, or alterations occurring after the date of manufacture. In no case shall the Company be liable for any consequential or incidental damages for breach of this or any other Warranty, expressed or implied whatsoever, even if the loss or damage is caused by the Company's negligence or fault. Some states do not allow the exclusion or limitation of incidental or consequential damages, so the above limitation or exclusion may not apply to you. This Warranty gives you specific legal rights, and you may also have other rights which vary from state to state.

Free Manuals Download Website

<http://myh66.com>

<http://usermanuals.us>

<http://www.somanuals.com>

<http://www.4manuals.cc>

<http://www.manual-lib.com>

<http://www.404manual.com>

<http://www.luxmanual.com>

<http://aubethermostatmanual.com>

Golf course search by state

<http://golfingnear.com>

Email search by domain

<http://emailbydomain.com>

Auto manuals search

<http://auto.somanuals.com>

TV manuals search

<http://tv.somanuals.com>