



OWNER'S GUIDE USE AND CARE MANUAL

MODEL MB10 & MB20

For Customer Assistance
CALL 1-800-325-6952

Congratulations: You have purchased a product of superior performance and design, which will give the best service when properly operated and maintained. These coolers can be used as convenient, roll-around spot coolers.

This guide was designed to provide you with the information needed to assemble the unit for roll-around spot-cooling. It also contains information on how to safely operate, inspect, maintain and troubleshoot your evaporative air cooler.

The first section, Assembly, contains instructions to prepare your cooler for roll-around portable service. The second section, Maintenance, contains operational and maintenance instructions to aid in keeping your unit in good working order, while Troubleshooting includes information to help diagnose and repair commonly encountered problems.

- * Safety
- * Installation
- * Operation
- * Maintenance
- * Trouble Shooting
- * Parts Replacement

READ THIS FIRST

READ AND SAVE THESE IMPORTANT SAFETY INSTRUCTIONS

WARNING - TO REDUCE THE RISK OF FIRE, ELECTRIC SHOCK, OR INJURY TO PERSONS, OBSERVE THE FOLLOWING.

Read all instructions carefully before installation.

This cooler must be connected to 120 VoltAC, 60 Hz (cycle) power only. NOTE: Improper voltage will void the pump and/or motor warranties and may cause serious personal injury or property damage.

This cooler must be plugged into a GFCI protected receptacle, which has been properly installed in accordance with all local and national codes. If you are not sure that the receptacle is GFCI protected, consult with a qualified electrician.

This cooler is equipped with a power cord having an equipment grounding conductor and grounding plug. Do not attempt to defeat this safety device by removing the grounding pin.

Do not step on or rollover power cord with heavy or sharp objects. Do not operate if plug or cord is damaged in any way. If the unit is damaged or malfunctions, do not continue to operate it.

Remove the plug from the electrical receptacle by pulling on the plug and not the cord.

Always disconnect electrical power to unit before attempting to work on or service your cooler.

Do not operate near open containers of flammable liquids or gases.

Do not operate this cooler (fan motor) with any solid-state speed control device.

Do not operate this unit with pad frame(s) and/or air outlet grille removed, this may cause the fan motor to overload and damage the motor.

Never wash your cooler cabinet with a garden hose, water may harm motor and pump.

NOTE:

Do not use indoors on carpet or wood floor. Unit may leak water and could damage flooring or create a slip hazard.

Do not locate or operate cooler near exhaust or vent pipes as odors or fumes may be drawn into unit.

Your warranty does not cover shipping damage. Report all shipping damage at once to store making the delivery.

For future reference, record the serial number and purchase date of your evaporative cooler here:

Serial # _____

Purchase Date: _____

Place of Purchase: _____

THE USE OF ANODE DEVICES, CHEMICAL ADDITIVES, OR COOLER CLEANER TREATMENTS IN THIS COOLER WILL VOID THE WARRANTY.

INTRODUCTION

Your evaporative air cooler was thoroughly tested and inspected before leaving the factory. This is your guide to economical, trouble free comfort cooling over the years with reasonable care and regular maintenance. Failure to follow these instructions may damage your cooler, impair its operation and/or void the warranty.

Read it carefully.

PREPARATION FOR ASSEMBLY

Unpacking the unit

Remove the pad frames by slightly lifting the pad frame from the bottom, pull outwards until clear of cabinet bottom pan, then downwards until frame clears cabinet top. Remove the following items from the cooler:

1. Box containing swivel casters and attachment hardware.
2. Plastic bag containing small parts, float valve, garden hose adapter, hose nut, hose washer, o-ring.
3. Bag with hose adapter for float valve (roll-around use)

Gather tools required to assemble & install unit

The following tools are required to assemble the unit:

- | | |
|------------------------------|--------------------|
| 7/16" box or open end wrench | 6" crescent wrench |
| 3/8" box or open end wrench | 1/4" nut driver |

SETUP FOR ROLL-AROUND USE

1. Open parts box & remove casters from parts bag. Assemble each caster (Fig.1) per caster plate using supplied 1/4-20 nuts & carriage bolts.
2. Place casters w/ brakes on the front of the unit, and the casters without the brakes should be mounted on the back of the cooler. Use 4 of the 1/4-20 bolts from the parts bag to secure all 4 of the casters to their respective caster plates. Apply brakes before lifting cooler upright to complete assembly.

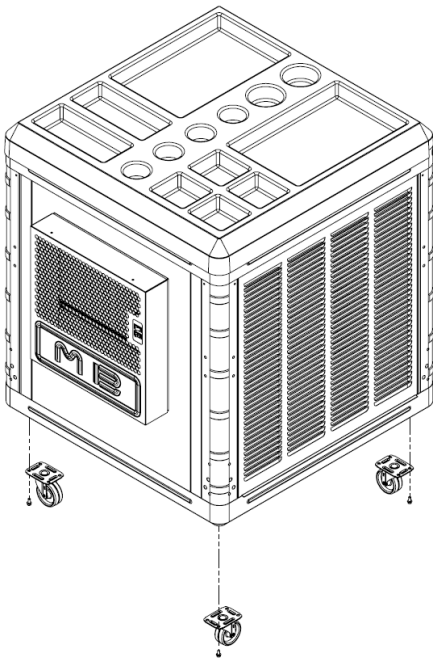

Figure 1

Install drain bushing and standpipe

Install overflow drain bushing in bottom of cooler. Slide rubber washer over drain bushing, push drain bushing through bottom of cooler, and tighten nut. Screw plastic overflow standpipe into the drain bushing and tighten snugly (hand-tight) to prevent leakage. Where conditions allow for drainage, connect a drain line (garden hose) to drain bushing and drain

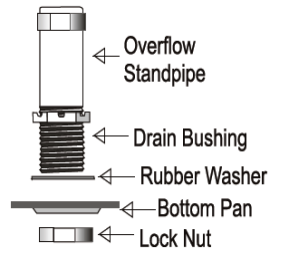

Figure 2

Install float valve and hose adapter

Attach the float valve to the cabinet as shown in The garden hose adapter attaches to the brass inlet fitting on the float valve (see). NOTE: verify that the hose washers are correctly in place.

Water connection and float adjustment

Move cooler to desired location (this should be a level area for proper operation of the cooler).

1. Locate a knock-out in the bottom of any of the four corner posts.
2. Connect to water supply using a commercial grade of water hose(not supplied with cooler, obtained separately) to the adapter on the float valve and turn water on. CAUTION: water inlet pressure should be limited to a maximum of 65 PSI to avoid rupturing the water hose. If pressure exceeds this value, an inline pressure regulator should be installed (obtainable from a local plumbing or hardware store).
3. Check that all connections are tight by visually inspecting hose, float valve, etc. for leakage.
4. Set float valve for a water depth of 2.5". The float is adjusted by lightly bending the float rod.

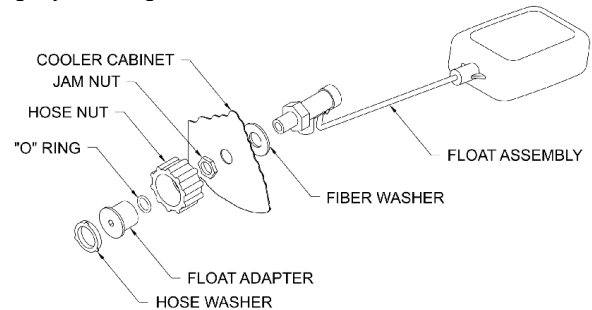

Figure 3

Cooler checkout and first time start-up

Congratulations, once you re-install the pad frames, your roll-around Master Blaster cooler will be complete and ready for use. Please proceed to the Pre-startup inspection checklist on page 3 before starting unit for the first time.

Motor and blower wheel check

Check motor mounting to be sure all screws and nuts are tightened down properly. Rotate blower wheel by hand to see that it moves freely without rubbing against housing.

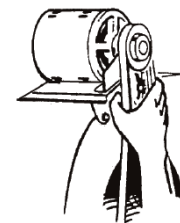

Figure 4

Electric Power

CAUTION:

This cooler is designed for connection to 120 volt AC, 60 Hz (cycle) power only. NOTE: Improper voltage will void the pump and/or motor warranties and may cause serious personal injury or property damage.

This cooler must be plugged into a GFCI protected receptacle, which has been properly installed in accordance with all local and national codes. If you are not sure that the receptacle is GFCI protected, consult with a qualified electrician.

This cooler is equipped with a power cord having equipment grounding conductor and grounding plug. Do not attempt to defeat this safety device by removing the grounding pin.

GENERAL INSPECTION

Pre-Start-up Inspection Checklist

Before start-up of the cooler motor and pump for the first time, or at the beginning of each cooling season, make sure all connections and adjustments have been made.

Cooler is on a level surface, casters locked to prevent unnecessary movement (prevent spillage).

- ✓ Power supply cord is plugged into a GFCI protected receptacle; cord is secure from accidental damage.
- ✓ Drain and float valve installed.
- ✓ Water hose connected securely without leaks.
- ✓ Water faucet or supply is turned on.
- ✓ Float adjusted for proper water level.
- ✓ Pad frames and air outlet grille correctly installed.
- ✓ Pump impeller turns freely. Remove impeller cover (see "Cleaning Pump"), and check rotation.
- ✓ Blower wheel, shaft, pulley and motor sheave set bolts/screws are snug. (see figure 4)
- ✓ Motor sheave / Blower pulley alignment is okay; belt tension is okay (see for instructions).

Start-up Checklist

CAUTION: Never operate unit with pad frame(s) and/or air outlet grille removed. This will result in an overloaded condition and may damage the fan motor. The motor and pump have an internal automatic thermal overload switch that will shut the motor and/or the pump off if it overheats! The motor and/or pump can restart automatically when they cool down.

To verify and check out the cooler installation on initial start-up, the following procedure should be followed.

- ✓ Push "COOL" switch to ON position (pump on).
- ✓ Verify that pump starts and pads are evenly wet.
- ✓ Open windows, doors or vents in building.
- ✓ Push "FAN" switch to LOW position (low speed on).
- ✓ Observe that motor starts and runs. Check high-speed function by turning "FAN" switch to HIGH (high speed on).
- ✓ When switching from Low to Hi speed you should pause in center position (OFF) for 2 seconds to extend motor life.

In case of trouble in any of these stages, refer to the Troubleshooting Chart on page 6.

Cabinet Inspection Checklist

After initial start-up and during periodic inspections, check for and/or observe the following: Refer to the Troubleshooting Chart on page 6 if necessary.

- ✓ Leaks from water lines, pad frames, cabinet, etc.
- ✓ Observe cooler pads for uneven wetting
- ✓ Confirm water level setting is correct.
- ✓ Verify full, even flow in water distribution system.
- ✓ Blower wheel / motor rotates freely.
- ✓ Belt condition / tension / alignment.
- ✓ Check that set screws on pulleys, blower wheel are tight.
- ✓ Check motor mounting and cabinet hardware.

OPERATING INSTRUCTIONS

Guidelines and location

Always make sure that the roll-around unit is operated on a solid, level surface strong enough to hold its weight (unit can weigh 270 lbs when full). Make sure the two locking casters have been locked to prevent the cooler from accidentally moving while in use. Use caution when rolling the unit to avoid splashing or spilling of water. Unless the move is for a short distance, it is best to drain the unit, move it and then refill it in its new location.

Controls

Rocker-type control switches are used to select the operating mode of the cooler. These switches control fan speed (FAN-HIGH/OFF/LOW) and the pump operation (COOL-ON/OFF).

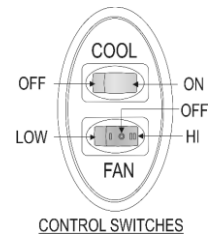

Figure 5

To eliminate a rush of warm air when starting the cooler, be sure to turn the pump (COOL) on for a few minutes before turning on the blower motor (FAN) in low or high speed.

Maintenance Schedule

Regular maintenance and periodic inspection is a key to long and successful service of your Master Blaster Cooler. The cooler should be serviced at least once a year or more often if required. For maximum efficiency, longer life and appearance, every two months during operation, the cooler should be inspected and cleaned.

Note: Do Not Undercoat the Water Reservoir

Your cooler's water reservoir is finished with our Peblar XT® appliance-type finish. Asphalt-type cooler undercoating will not stick to it. Undercoating will break free, clogging the pump and water distributor.

NOTE: Do not use cooler cleaners, cooler treatments or other chemical additives in this evaporative cooler. Use of any additives or water treatment other than bleed-off will void your warranty and impair the life of the cooler.

Before starting any maintenance operation, read all operating and maintenance instructions and observe all cautions and warnings thoroughly.

CAUTION: Disconnect all electrical power to the cooler by removing plug from receptacle before attempting to install, open, or service your cooler.

Even while routinely inspecting or servicing the inside, the cooler can be accidentally started. Keep all personnel away from the cooler and electrical supply when you are working on it. Before servicing or cleaning unit, switch "COOL" and "FAN" to the OFF position and remove power cord from receptacle.

All foreign materials, scale, salt deposits, lime, etc. can and should be removed from louvers, bottom pan, and other components. Your cooler's long lasting finish can be brought to like-new condition by using warm water and a soft cloth.

NOTE: Avoid using scouring pads, steel wool or wire brushes, as these will damage the finish and encourage corrosion.

Maintenance & Inspection

CAUTION: Disconnect all electrical power to the cooler by removing the plug from the receptacle before attempting to install, open, or service your cooler.

IMPORTANT: Before operating cooler at beginning of each cooling season, turn blower wheel, cooler motor and pump motor shafts by hand to make sure they turn freely. Failure to do so may result in burning out the motor.

Periodic inspection of your cooler will enhance long, trouble-free service life. For maximum efficiency, every two months during operation, or any time the cooler is opened, the cooler should be inspected. Some suggested items:

- ✓ Check for leaks from pad frames, cabinet, etc.
- ✓ Are there any dry spots on the media when cooler is in operation?
- ✓ Are bolts, nuts and set screws snug?
- ✓ Are the bearings making unusual noises?
- ✓ Does the blower wheel turn freely?
- ✓ Is float level set correctly?
- ✓ Is water in the bottom pan clean?
- ✓ Belt condition / tension / alignment?

Set Screws, Bolts and Nuts

Check torque on set screws and cabinet hardware:

- ✓ Motor and Blower Pulley set screws (95 in-lbs.)
- ✓ Blower Wheel set screws (1 per side, 150 in-lbs)
- ✓ Cabinet hardware (25 in-lbs)

CAUTION: Disconnect all electrical power to the cooler and insure that belt is not rotating before adjusting belt tension.

Adjust Belt Tension

Each time you inspect your cooler, be sure to check belt tension on motor/blower assembly. Check belt condition and replace it if trays or cracks appear. Check alignment of blower pulley with motor pulley.

Cleaning Water Pump & Hose

CAUTION: Do not allow pump to fall over and become submerged; water will damage pump motor.

Clean water pump and hose assembly as follows:

1. Unplug pump cord, remove mounting bracket screw and remove pump from cooler. Shake gently to remove water.
2. To prevent breakage, carefully release and remove impeller base plate from the pump body. (see figure 9)
3. Using a mild detergent solution and clean cloth, clean deposits from pump screen, around impeller and base plate.
4. Spin impeller to dislodge any foreign material.
5. Remove any foreign material in the adapter between the pump and hose, or between the hose and the water distributor assembly.
6. Rinse and reinstall impeller base plate.
7. Reinstall pump and reconnect pump cord.

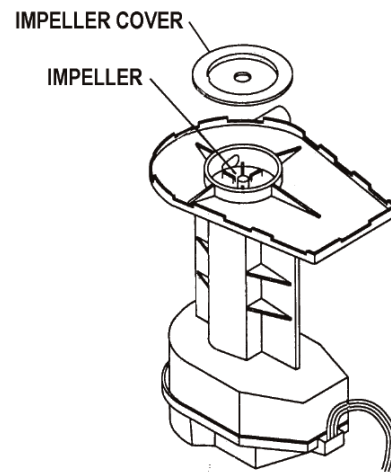

Figure 6

Draining

Drain the cooler cabinet (with power off and panels removed) as follows:

1. Connect a drain hose to the drain fitting on the bottom of the reservoir, if not already connected to drain line.
2. Remove overflow standpipe from the drain fitting.
3. Drain, clean and dry reservoir.

Touch-Up

The hardness, adhesion and smoothness of the internal and external finish on your cooler makes it extremely unlikely that scratches or chipping will occur. In the event that finish damage does occur, it should be promptly repaired by the following procedures:

1. Sand the area around bare metal spots.
2. Prime and paint with a quality paint.

Do not use asphalt type cooler undercoat material in water reservoir. Undercoat will break free, clogging the pump and water distributor.

LUBRICATION

Motor Bearings

Some motors used in Master Blaster coolers have ports for lubricating the motor and are oiled at the factory. They should be checked after 20-30 days of operation. If the need for oiling is indicated, see the motor nameplate for specific instructions on re-

lubricating the motor. Under normal use, these motors require oiling about every 12 months of operation.

Do Not Over-Oil.

Blower Shaft Bearings

Blower shaft bearings need periodic lubrication. The oil cups on the bearings should be filled with SAE 30W non-detergent oil when necessary. Under normal use, oiling is required every three months of operation.

Do Not Over-Oil.

Pump Bearings

The pump motor bearings are permanently lubricated

Changing Cooler Pads

Scale may build up on outside of the Rigid Pad, which will restrict the airflow. The Rigid Pad should be removed and replaced if scale cannot be removed using the methods described below. Failure to do so may result in premature failure of components.

Replace pads as follows:

1. Remove pad assembly from cabinet.
2. Remove pad retainers from frame. Carefully remove all rigid media from the louver panel, paying attention to the bottom of the media as there is a cut made at the bottom. Remove and discard old pads.
3. If passages are clogged or pad is dirty, hose off the inlet face of the pad. Light, gentle brushing of the inlet edges of the pad with a stiff bristle brush (don't use a wire brush) will not harm the pad and will remove stubborn scaling.
4. If necessary, replace with new rigid media pads. Aspen, expanded paper or other types of evap cooling pads will not work and will void your warranty.
5. Lay new rigid media pads into the louver panel assy., paying attention to how the slit at the bottom of the pad is oriented.
6. Return the rigid media retainer so that it fits on top of the rigid media pads and holds them securely against the louver panel.
7. Pre-soak pads and check for air gaps along edges, reinstall pad frames into unit.
8. Start pump and allow troughs to fill... check water level in troughs by slightly tilting each pad frame out.

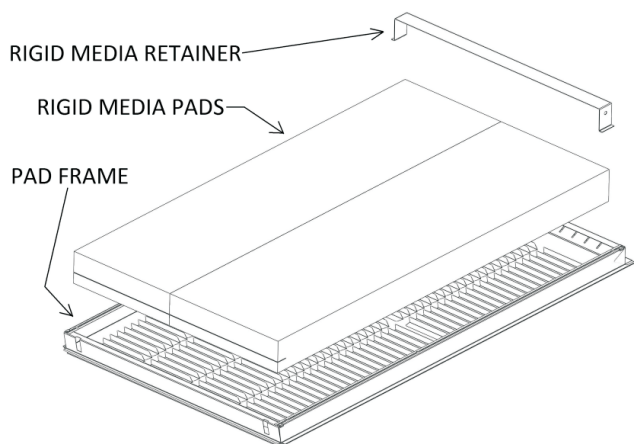
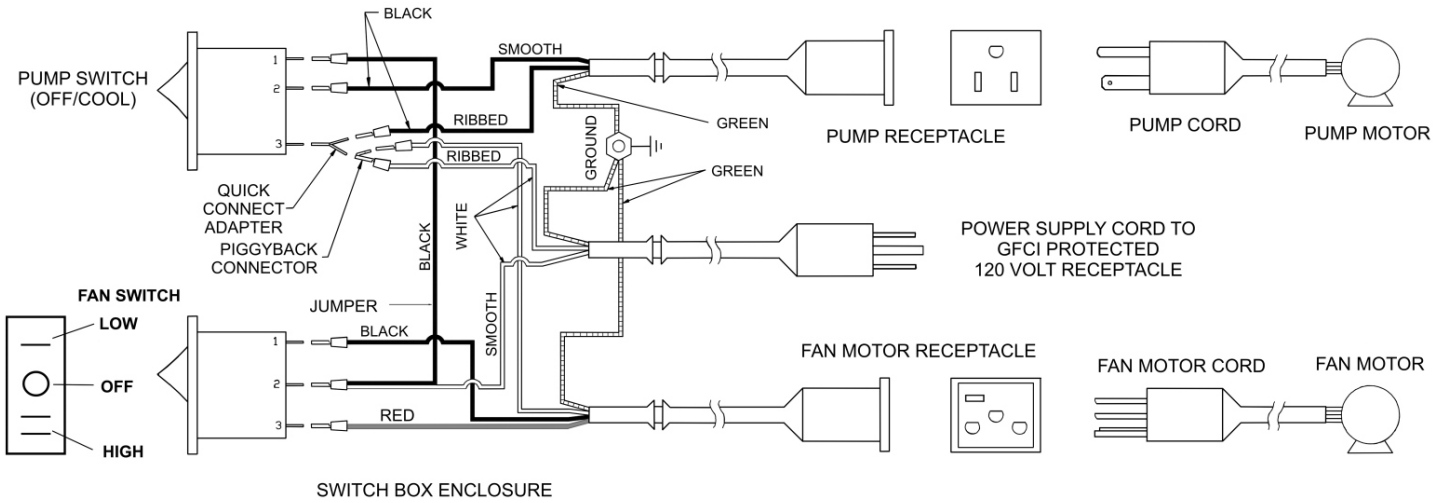

Figure 7

Replacement

When ordering replacement parts, always refer to the serial and model number of your cooler. Use the part numbers listed in the accompanying parts list, as illustrated in the diagrams for your model.

WIRING DIAGRAM



TROUBLESHOOTING GUIDE: Should an obvious problem occur with your cooler consult the following table. If you cannot correct the problem, or if it persists, contact qualified service personnel.

PROBLEM / SYMPTOM	POSSIBLE CAUSE	CORRECTIVE ACTION
Water draining from unit	Float valve out of adjustment	Adjust float to 2 1/2" water depth
	Float movement obstructed	Free float from obstruction
	Float valve non-functional	Replace float assembly
Dry pads	Pump intake clogged	Remove obstruction
	Water pump non-functional	Replace water pump
	Clogged water line	Locate and free obstruction
	Pad trough clogged	Clear debris from trough
	Switch non-functional	Replace switch
	Wiring non-functional	Repair or replace non-functional wiring
	Water turned off to cooler	Turn on water supply
Motor does not start or no air delivery	Electrical power disconnected	Check power receptacle and cord
	Belt too loose or too tight	Adjust belt tension
	Non-functional motor	Replace motor
	Non-functional switch	Replace switch
	Broken belt	Replace belt
Inadequate air delivery	Insufficient air exhaust	Open windows to increase air flow
	Belt too loose	Adjust belt tension or replace is needed
	Pads plugged	Replace pads
Motor cycles on & off	Low voltage	Check voltage
	Excessive belt tension	Adjust belt tension
	Blower shaft tight or locked	Oil or replace bearings
	Bearings dry	Oil bearings
	Pad frame(s) or air outlet grille removed	Re-install pad frame(s) or air outlet grille
Noisy operation	Blower rubbing on housing	Reposition wheel
	Motor sheave or blower set screws loose	Tighten set screws
Excessive humidity in house	Inadequate exhaust	Open doors and windows to increase ventilation

Free Manuals Download Website

<http://myh66.com>

<http://usermanuals.us>

<http://www.somanuals.com>

<http://www.4manuals.cc>

<http://www.manual-lib.com>

<http://www.404manual.com>

<http://www.luxmanual.com>

<http://aubethermostatmanual.com>

Golf course search by state

<http://golfingnear.com>

Email search by domain

<http://emailbydomain.com>

Auto manuals search

<http://auto.somanuals.com>

TV manuals search

<http://tv.somanuals.com>