

VEC049D  
VEC050D  
VEC051D  
VEC053D  
VEC054D  
VEC056D



# MAXX SST™

## Compact Power Inverters

Converts 12 Volt DC to 120 Volt AC  
Advanced MOSFET Technology



VEC049D



VEC053D



VEC050D



VEC054D



VEC051D



VEC056D

### USER'S MANUAL & WARRANTY INFORMATION

**IMPORTANT SAFETY INFORMATION, SAVE THESE INSTRUCTIONS**

TO REDUCE THE RISK OF INJURY, USER MUST READ AND UNDERSTAND THIS INSTRUCTIONAL MANUAL. THIS MANUAL CONTAINS IMPORTANT INFORMATION REGARDING THE OPERATION AND WARRANTY OF THIS PRODUCT. PLEASE RETAIN FOR FUTURE REFERENCE.

4140 S.W. 30th Ave., Ft. Lauderdale, FL 33312  
Toll Free: (866) 584-5504

[www.vectormfg.com](http://www.vectormfg.com)

### SPECIFICATIONS

1. These models feature multiple U ground 120 volt AC outlets.
2. All of these inverters meet North American Standard Requirements.

Power Inverter Model	VEC049D	VEC053D	VEC050D	VEC054D	VEC051D	VEC056D	VEC051D
Maximum Continuous Power	1000 watts	1200 watts	1500 watts	2000 watts	2500 watts	3000 watts	3000 watts
Surge Capacity (Peak Power)	2000 watts	2400 watts	3000 watts	4000 watts	5000 watts	6000 watts	6000 watts
Rated Input Voltage	12.8 - 13.2 volts	12.8 - 13.2 volts	12.8 - 13.2 volts	12.8 - 13.2 volts	12.8 - 13.2 volts	12.8 - 13.2 volts	12.8 - 13.2 volts
Output Voltage Range	105 - 125 volts	105 - 125 volts	105 - 125 volts	105 - 125 volts	105 - 125 volts	105 - 125 volts	105 - 125 volts
Output Frequency	58 - 62 Hz	58 - 62 Hz	58 - 62 Hz	58 - 62 Hz	58 - 62 Hz	58 - 62 Hz	58 - 62 Hz
Output Voltage	110/120VAC 60 Hz	110/120VAC 60 Hz	110/120VAC 60 Hz	110/120VAC 60 Hz	110/120VAC 60 Hz	110/120VAC 60 Hz	110/120VAC 60 Hz
Maximum Efficiency	≥87%	≥87%	≥87%	≥87%	≥87%	≥87%	≥87%
Full Load Efficiency	≥82%	≥82%	≥82%	≥82%	≥82%	≥82%	≥82%
No Load Current Draw	<0.5 amp	<0.6 amp	<0.6 amp	<0.8 amp	<1.0 amp	<1.0 amp	<1.0 amp
Over Voltage Shutdown	15.5 ± 0.5 volts DC	15.5 ± 0.5 volts DC	15.5 ± 0.5 volts DC	15.5 ± 0.5 volts DC	15.5 ± 0.5 volts DC	15.5 ± 0.5 volts DC	15.5 ± 0.5 volts DC
Low Voltage Alarm	10.5 ± 0.3 volts DC	10.5 ± 0.3 volts DC	10.5 ± 0.3 volts DC	10.5 ± 0.3 volts DC	10.5 ± 0.3 volts DC	10.5 ± 0.3 volts DC	10.5 ± 0.3 volts DC
Low Voltage Shutdown	10.0 ± 0.3 volts DC	10.0 ± 0.3 volts DC	10.0 ± 0.3 volts DC	10.0 ± 0.3 volts DC	10.0 ± 0.3 volts DC	10.0 ± 0.3 volts DC	10.0 ± 0.3 volts DC
Thermal Shutdown Auto Reset	YES	YES	YES	YES	YES	YES	YES
North American Standard Outlets	2	2	3	3	4	4	4
ANL Fuse Rating for Direct Hardwire	200	250	300	500	500	500	500
Proper Cable Gauge (AWG) @ 6 FT.	#3	#3	#2	1/0	2/0	2/0	2/0
Proper Cable Gauge (AWG) @ 10 FT.	#1	1/0	2/0	3/0	3/0	250 mcm	250 mcm

\*For lengths greater than 10 FT., contact Vector's Technical Support, tollfree, at (866) 584-5504

# **IMPORTANT SAFETY INSTRUCTIONS**

To ensure reliable service, your power inverter must be installed and used properly. Please read the installation and operating instructions thoroughly prior to installation and use. Pay particular attention to the WARNING and CAUTION statements in this User's Manual. The CAUTION statements advise against certain conditions and practices that may result in damage to your inverter. The WARNING statements identify conditions or practices that may result in personal injury.

## **WARNINGS**

**TO REDUCE THE RISK OF FIRE, ELECTRIC SHOCK, EXPLOSION OR INJURY:**

- **NEVER connect to AC distribution wiring.**
- **Remove appliance plug from outlet strip or turn off inverter before working on the appliance. Multiple outlet power strips with switches and circuit breakers only interrupt power to the "hot" receptacle terminals. The "neutral" terminals remain powered with respect to the "ground" terminals.**
- **NOT approved for ignition protected areas. Do not make any electrical connections or disconnections in areas designated as IGNITION PROTECTED.**
- **This is not a toy — keep away from children.**
- **This equipment employs components that tend to produce arcs or sparks. DO NOT install in compartments containing batteries or flammable materials.**
- **Use this unit in properly ventilated areas ONLY.**
- **Do not open — there are no user-serviceable parts inside.**
- **Do not insert foreign objects into the outlets.**
- **Do not expose the unit to liquids, including water, rain or snow.**

## **CAUTIONS**

- Always inspect battery supply connections and cables to ensure they are tight and that cable insulation is not damaged.
- Do not use with positive ground electrical systems\*. Reverse polarity connection will result in a blown fuse and may cause permanent damage to the inverter and will void warranty.  
*\*The majority of modern automobiles, RVs, trucks and boats are negative ground.*
- Grounding the Neutral will cause the inverter to shut down. Do not operate this inverter if it is wet. Do not install in engine compartment — install in a well ventilated area.
- This inverter has not been tested for use with medical devices.
- Do not attempt to install or operate this unit while operating a motor vehicle.

## **APPLIANCE CAUTIONS**

NEVER plug small appliances directly into the inverter outlets to recharge nickel-cadmium batteries. Always use the charger provided with the appliance.

NEVER plug in battery chargers for cordless power tools if the charger carries a warning that dangerous voltages are present at the battery terminals.

Certain chargers for small nickel-cadmium batteries can be damaged if plugged into the inverters. DO NOT use inverters with the following two types of equipment.

1. Small, battery-operated appliances such as flashlights, cordless razors and toothbrushes that can be plugged directly into an AC receptacle to recharge.
2. Battery chargers that have a warning label stating that dangerous voltages are present at the battery terminals.

The majority of portable appliances do not have this problem. Most portable appliances use separate transformers or chargers that plug into AC receptacles to supply a low DC or AC voltage output to the appliance. If the appliance label states that the charger or adapter produces a low DC or AC voltage output (30 volts or less), there should be no problem powering that charger or adapter.

Some fluorescent lamps may not operate properly with this type of inverter. If the bulb appears to be too bright, or fails to light, do not use the lamp with this inverter.

Some fans with synchronous motors may slightly increase in speed (RPM) when powered by the inverter. This is not harmful to the fan or to the inverter.

## **Important Cable Information**

Substantial power loss and reduced battery operating time results from inverters installed with cables that are not able to supply full power. Symptoms of low battery power can result from cables that are either excessively long or an insufficient gauge. Marine installations are also subjected to vibration and stresses that exceed those of other mobile installations. Therefore, the installer/operator should be especially aware of the requirements to maintain secure, tight, water-resistant electrical connections and to provide for strain relief for DC cables and appliance wiring. Cable insulation must be the appropriate type for the environment.

**Read All Instructions Before Using This Power Inverter!**

## **SAVE THESE INSTRUCTIONS**

# TABLE OF CONTENTS

Introduction	1
Features	1
VEC049D & VEC053D Diagrams	2
VEC050D & VEC054D Diagrams	2
VEC051D & VEC056D Diagrams	3
MAXX SST Safety Features	3
Principle of Operation	4
Appliance Power Consumption	5
Appliance Consumption in Amps and Watts Chart	6
Operating Instructions	7
Power Source Requirements	7
Determining Battery Size	8
Runtime	8
Protective Features	9
Installation	10
Operating Environment	10
Installation Procedures	11
Connection To Load	13
Operating Tips	13
Notes on Using the Remote Control (sold separately)	14
Care and Maintenance	14
Storage	14
Fuse Replacement	14
Preventive Maintenance	14
Troubleshooting	15
Common Audio/Visual Problems	15
Resetting the Unit	15
Fault Protection and Troubleshooting Guide	15
Specifications	16

## TWO YEAR LIMITED WARRANTY PROGRAM

This limited warranty program is the only one that applies to this product, and it sets forth all the responsibilities of Vector Manufacturing, regarding this product. There is no other warranty, other than those described herein. Any implied warranty of merchantability or fitness for a particular purpose on this product is limited in duration to the duration of this warranty.

This Vector Manufacturing product is warranted, to the original purchaser only, to be free of defects in materials and workmanship for two years from the date of purchase without additional charge. The warranty does not extend to subsequent purchasers or users. Manufacturer will not be responsible for any amount of damage in excess of the retail purchase price of the product under any circumstances. Incidental and consequential damages are specifically excluded from coverage under this warranty.

This product is not intended for commercial use. This warranty does not apply to damage to units from misuse or incorrect installation/connection. Misuse includes wiring or connecting to improper polarity power sources.

**RETURN/REPAIR POLICY:** Defective products may be returned to manufacturer. Any defective product that is returned to manufacturer within 30 days of the date of purchase will be replaced free of charge. If such a product is returned more than 30 days but less than two years from the purchase date, manufacturer will repair the unit or, at its option, replace it, free of charge.

If the unit is repaired, new or reconditioned replacement parts may be used, at manufacturer's option. A unit may be replaced with a new or reconditioned unit of the same or comparable design. The repaired or replaced unit will then be warranted under the terms of the remainder of the warranty period. The customer is responsible for the shipping charges on all returned items. During the warranty period, manufacturer will be responsible for the return shipping charges to the customer in the United States.

**LIMITATIONS:** This warranty does not cover accessories, such as charging adapters, bulbs, fuses and batteries, damage or defects resulting from normal wear and tear (including chips, scratches, abrasions, discoloration or fading due to usage or exposure to sunlight), accidents, damage during shipping to our service facility, alterations, unauthorized use or repair, neglect, misuse, abuse, failure to follow instructions for care and maintenance, fire, flood and Acts of God.

If your problem is not covered by this warranty, call our Technical Support Department at (954) 584-4446 or toll free at (866) 584-5504 for general repair information and charges if applicable. You may also contact us through our website at [www.vectormfg.com](http://www.vectormfg.com).

**STATE LAW RIGHTS:** This warranty gives you specific legal rights. Some states do not allow limitations on how long an implied warranty lasts or the exclusion or limitation of incidental or consequential damages, so the exclusions or limitations stated herein may not apply. This warranty gives the purchaser specific legal rights; other rights, which vary from state to state, may apply.

**TO REQUEST WARRANTY SERVICE FOR THIS PRODUCT:** Contact Technical Support by telephone, fax or mail (see below). We suggest that you keep the original packaging in case you need to ship the unit. When returning a product, include your name, address, phone number, dated sales receipt (or copy) and a description of the reason for return and product serial number. After repairing or replacing the unit, we will make every effort to return it to you within four weeks.

**WARRANTY ACTIVATION:** Please complete Warranty Activation Card and mail to Vector Manufacturing. Enter the appropriate model number as Model and "MAXX SST" Compact Power Inverter" as Product Type. All Vector products must be registered within 30 days of purchase to activate this warranty. Mail the completed registration form, along with a copy of the original sales receipt, to:

ATTN.: CUSTOMER SERVICE  
1410 SW 30th Ave., Ft. Lauderdale, FL 33312  
• TOLL FREE: (866) 584-5504 • FAX: (954) 584-5556 •

WARRANTY IS NON-TRANSFERABLE.

BD012606

© 2006 VECTOR MANUFACTURING  
MADE IN CHINA

## INTRODUCTION

Thank you for purchasing a **Vector Power Inverter**. Please read this guide carefully before use to ensure optimum performance and to avoid damage to this product.

This Power Inverter is configured with the latest Soft Start Technology (SST) and supplies continuous power and peak watts in the form of 120 volt AC outlets to run most household or electronic appliances. Before introduction of SST, high start-up currents from large inductive loads could shut down an inverter. SST improves inverter operation by:

- Gradual voltage ramp-up during inverter start-up, eliminating failed cold starts under load.
- Output that momentarily dips in voltage and quickly recovers to allow large motorized loads to start, eliminating most shutdowns from momentary overloads.
- A new technology that cools the power transistors more efficiently, and, combined with Soft Start, dramatically increases reliability and life of the product.

Added safety features include automatic shutdown and a low battery alarm to prevent damage to your battery.

## FEATURES

On the front panel are two LED indicators. The green LED indicates power and proper operation of the inverter, the red LED indicates inverter shutdown from over-load or over-temperature condition, or abnormal input voltages. The ON/OFF Switch turns the inverter ON and OFF. The switch can also be used to force reset of inverter circuits by switching it OFF, then back ON again. All models also feature a port to attach a remote control (sold separately).

120 volt AC power is supplied through North American three-prong type outlets. The VEC049D and VEC053D feature two outlets; the VEC050D and VEC054D feature three; and the VEC051D and VEC056D feature four. The outlets can accommodate either two- or three-pin AC plugs.

### VEC049D & VEC053D Front View Diagram

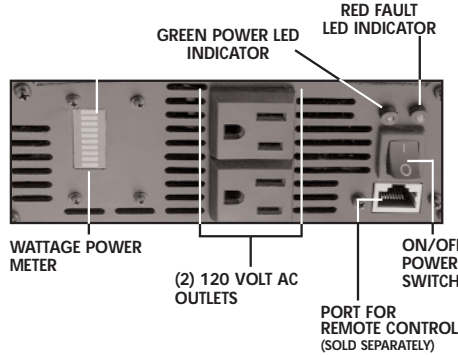

### Back View Diagram

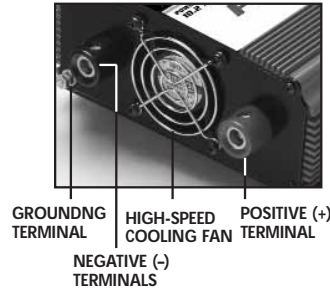

### VEC051D & VEC056D Front View Diagram

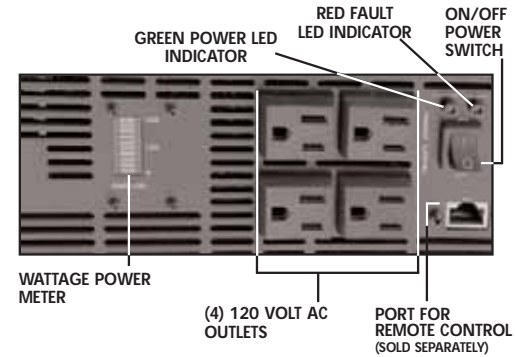

### VEC050D & VEC054D Front View Diagram

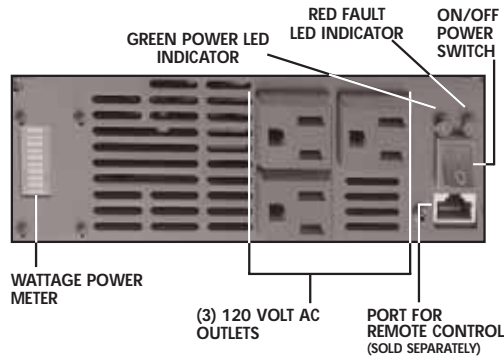

### VEC051D Back View Diagram

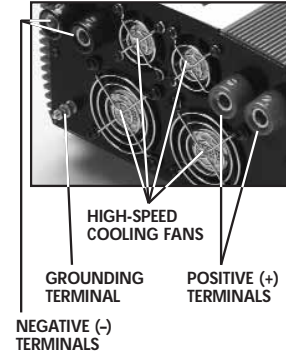

### VEC056D Back View Diagram

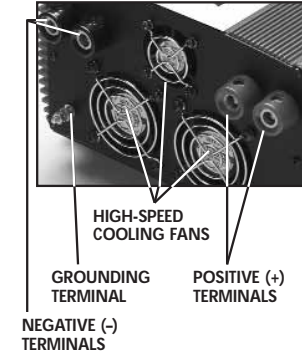

### VEC050D Back View Diagram

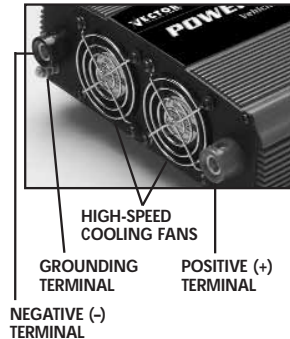

### VEC054D Back View Diagram

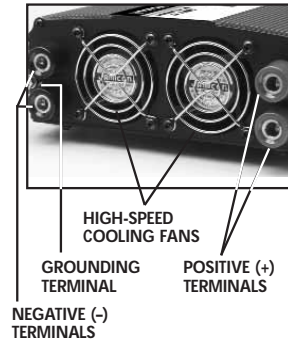

## MAXX SST™ Safety Features

Built-in Automatic Safety Features include:

- Overload and over-temperature shutdown activated if AC output exceeds rated watts
- AC short-circuit shutdown
- Low voltage audible alarm (sounds at 10.5 volts input)
- Low-voltage shutdown (activates at 10.0 volts DC)
- High-input voltage shutdown (activates at above 15.5 volts DC)

MAXX SST™ uses a 12 volt DC power source like those found in motor vehicles, or it can be operated using multiple battery configurations with commercial battery chargers or solar battery chargers. For most heavy-duty applications, a multiple battery configuration and the use of deep-cycle batteries is required.

When using multiple batteries, inverters can be operated from one of the vehicle 12 volt batteries, so there's always one battery with adequate charge to start an engine. MAXX SST™ includes a high-surge capability. This is required to start heavy loads, such as motors and other inductive devices.

## PRINCIPLE OF OPERATION

The MAXX SST™ inverter converts 12 volt DC (direct current) from a vehicle battery or other 12 volt DC power source to standard 120 volt AC (alternating current) household power.

It converts power in two stages (see the diagram below). In the first stage, the inverter raises the 12 volt DC input to 145 volts DC. This MAXX SST™ inverter uses high-frequency conversion techniques that replace bulky and heavy transformers found in older inverters. In the second (output) stage, the inverter converts the 145 volt DC to 110/120 volt AC using multiple banks of metal-oxide semiconductor field-effect transistors (MOSFETs). The unit's solid-state circuitry ensures excellent overload protection and the ability to operate reactive loads such as those found in inductive motors. In this stage, the inverter functions as a high-power bipolar switch, alternately applying opposite polarity to the AC outlet HOT and NEUTRAL terminals.

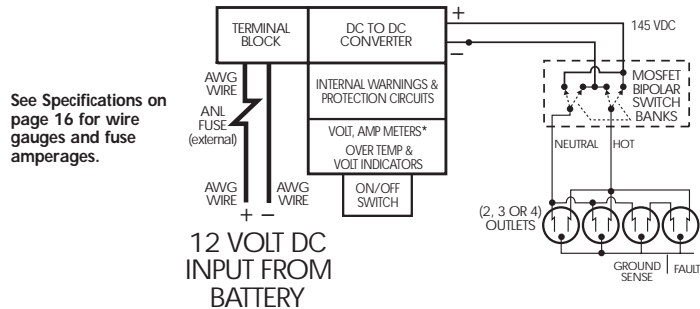

See Specifications on page 16 for wire gauges and fuse amperages.

### Notes: Simplified diagram.

Cables, fuse and battery are not included and must be supplied by user.

### The Power Inverter Output Waveform

The AC output waveform of the Power Inverter is known as “modified sine wave.” It is a waveform that has characteristics similar to the sine wave shape of utility power. This type of waveform is suitable for most AC loads, including linear and switching power supplies used in electronic equipment, transformers, and motors.

The modified sine wave produced by the Power Inverter has an RMS (root mean square) voltage of 115 volts, which is the same as standard household power. Most AC voltmeters (both digital and analog) are sensitive to the average value of the waveform rather than the RMS value. They are calibrated for RMS voltage under the assumption that the waveform measured will be a pure sine wave. These meters will not read the RMS voltage of a modified sine wave correctly. They will read about 20 to 30 volts low when measuring the output of the inverter. For accurate measurement of the output voltage of this unit, use a true RMS reading voltmeter such as a Fluke 179, Fluke 79 III series, Beckman 4410 or Triplet 4200.

### Modified Sine Wave and Sine Wave Comparison

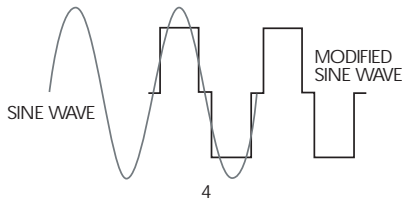

## APPLIANCE POWER CONSUMPTION

MAXX SST™ inverters are ideal for powering:

- Lights
- TVs and TV/DVD (VCR) combinations units
- Radio receivers/transceivers and stereo systems
- Computers and peripheral equipment
- Refrigerator/freezers
- Small microwave ovens
- Household appliances
- Dry and/or wet/dry vacuums
- Heavy duty power tools & chargers
- Sump pumps, motors and other electric-powered equipment

Most electrical tools, appliances and audio/video equipment have labels that show the unit's power consumption in amps, watts, or both. To avoid inverter shutdown and possible damage to the inverter, avoid exceeding the wattage rating of this unit. To obtain a rough estimate of the current (in amperes) the power source must deliver where the power consumption of the tool or device is given in watts AC, simply divide the power consumption of the load by 10.

Example: If a load is rated at 200 watts AC, the power source must be able to deliver: 200 divided by 10 = 20 amperes.

The inverter has built-in overload protection so that if you do exceed the inverter's output capacity continuously, the unit will automatically shut down. Once the excessive load is removed, the inverter can be restarted and resume normal operation.

**Note:** To restart the inverter, turn it OFF, and then ON again. The ON/OFF Switch is located on the unit's Front Panel (see page 2).

The inverter powers resistive loads the easiest; however, larger resistive loads, such as electric stoves or heaters, could draw more wattage than the inverter can deliver on a continuous basis.

### ⚠ CAUTIONS

**Ensure that total continuous power consumption of all tools and/or appliances connected to the inverter (and in use) does not exceed the inverter's continuous watts rating. Also ensure that start-up wattage for inductive loads does not exceed peak watts for more than a second.**

**Appliances such as microwave ovens will normally draw more than their rated current and could possibly overload the inverter when operating simultaneously with other appliances. For example: A 600 watt microwave oven draws approximately 940 watts.**

The following chart shows the approximate amperage and corresponding wattage at 120 volts AC for various common tools and appliances.

## Appliance Consumption in Amps and Watts Chart

APPLIANCE	AMPS@ 120VAC	WATTS@ 120VAC
Laptop Computer	0.5	55
Household Power Mixer	2	220
240-Watt Stereo/Amplifier	2.2	242
Refrigerator	3	330
3/8" Variable Speed Drill	3	330
Variable Speed Jig Saw	3	330
10-Speed Blender	3.2	352
Belt Sander	3.4	374
3/8" Reversible Drill	3.5	385
Household Food Processor	3.6	396
Computer and Monitor	4	440
Portable Vacuum	4.6	506
8-Cup Coffee Maker	5.5	605
Electric Trimmer	5.5	605
1/2" Hammer-Drill	5.5	605
Reciprocating Saw	6	660
Vacuum Cleaner	7.2	792
1-1/8" Rotary Hammer	7.8	858
1/6 H.P. Submersible Sump Pump	8	880
Compact Microwave Oven	8.5	935
10" Bench Saw	13.0	1500

**Note:** Appliance specifications may vary from brand to brand. This table is offered only as a guide to approximate power ratings. Check appliance manuals or product labeling for actual ratings. For continuous use at maximum output, the MAXX SST™ inverter must be connected to a DC power supply capable of providing at least 1/10th of the inverter's continuous wattage rating.

The inverter will operate most AC loads within its power rating. Some induction motors used in refrigerators, freezers, pumps and other motor-operated equipment, require very high surge currents to start them. The inverter may not be able to start some of these motors even though their rated current draw is within specifications for this power inverter.

If a motor refuses to start, observe the battery voltage using a DC voltmeter while trying to start the motor. If the battery voltmeter drops below 11 volts while the inverter is attempting to start the motor, this may be why the motor won't start. Make sure the

battery connections are tight and the battery (or batteries) is (are) fully-charged. If the connections are good and the battery is charged, but the voltage still drops below 11 volts, you may need to use a larger battery (or battery combination).

### ⚠ CAUTION

#### Rechargeable Devices

Certain rechargeable devices do not operate well from a modified sine wave inverter. They only operate properly from a standard household outlet, which provides a pure sine wave. Therefore, the manufacturer recommends that these types of devices be operated from a standard household outlet only, not from the inverter.

This problem does not occur with most battery-operated equipment. Most of these devices use a separate charger or transformer that is plugged into an AC receptacle. This inverter is easily capable of running most chargers and transformers.

## OPERATING INSTRUCTIONS

### Power Source Requirements

The inverter will operate from input voltages between 11 and 15 volts DC. If the voltage drops below 10.5 volts, an audible low battery warning alarm will sound. The inverter will shut down if the input voltage drops below 10 volts DC. This built-in feature protects the battery from being completely discharged.

The inverter will also shut down if the input voltage exceeds 15.5 volts. This protects the inverter against excessive input voltage. Although the inverter has built-in protection against over voltage, it may still be damaged if the input voltage exceeds 15.5 volts.

Inductive loads, such as TVs and stereos, require more current to operate than do resistive loads with the same wattage rating. Induction motors, as well as some TVs, may require two to six times their rated wattage to start up. Because the MAXX SST™ inverters have a peak watt power rating, many such appliances and tools may be safely operated. The equipment that needs the highest starting wattage are pumps and compressors that start under load. This equipment can be safely tested. If an overload is detected, the inverters will simply shut down until the overload situation is corrected. Use the front panel switch to turn OFF the inverter, then ON, to reset the inverter.

### ⚠ CAUTIONS

Exceeding recommended voltage limits will void manufacturer's warranty.

**NEVER try to use the inverter with any 12 volt DC power source that uses a POSITIVE ground. (Most vehicles and boats use negative ground systems.)**

The DC power source must be a well-regulated DC power supply as typically found in vehicle and deep-cycle marine batteries. The DC power source may also be two 12 volt batteries connected in parallel. On larger applications the power source may be several batteries connected in parallel as shown in the following "Battery Wiring" diagram.

## Battery Configuration

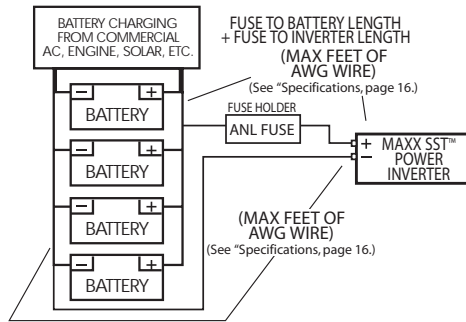

**Note:** For typical heavy-duty uses, Vector recommends a specified or equivalent ANL fuse be added as close as possible to the power source (battery) positive terminal. The fuse amperage size must be appropriate to allow simultaneous operation of all the AC appliances to be powered, with delay characteristics that allow for the momentary high start-up current requirements of inductive loads. Use the recommended fuse block (fuse holder) and fuse, or an electrical equivalent. For full rated output and motor start-up surge output, ensure that the installation is configured to handle the full load. See "Specifications" on page 16.

## Determining Battery Size

To determine the minimum battery size you will need to operate appliances from MAXX SST™ inverters, follow these steps:

1. Determine the wattage of each appliance and/or tool you will need to simultaneously operate from the inverter. To do this, read the labels on the equipment to be operated.
2. Estimate the number of hours the equipment will be in use between battery recharges.
3. Determine the total watt-hours of energy use, the total running time and the average power consumption.

Keep in mind that some appliances are not drawing the same power continuously. For example, a typical home-use coffee maker draws 500 watts during brew time (approx. 5 minutes), but maintains the pot temperature at only about 100 watts. Typical use of a microwave is only for a few minutes, sometimes at low power.

## Runtime

The following graph is a set of curves that show how appliance load, in watts or in amperes, affects runtime. These curves are only estimates of operating time, dependent upon:

- The condition of the batteries
- The state of charge on the batteries
- The amount of other DC appliances drawing current from the batteries

Three curves were developed for a battery of 50 Ampere Hours (AH) capacity, and three for multiple batteries in parallel. The higher capacity curves are for 120 AH, 200 aH and 400 aH capacities. These large capacity batteries clearly extend

operating time at full load. To extend operating time in general, reduce the heavy appliance load to a minimum. Remember, you are operating on stored energy and probably under power loss conditions.

**Note:** All operating time curves assume permanent installation with the appropriate DC input wire (See the "Specifications" section on page 16) and a full charge on the batteries.

## Battery Operating Times

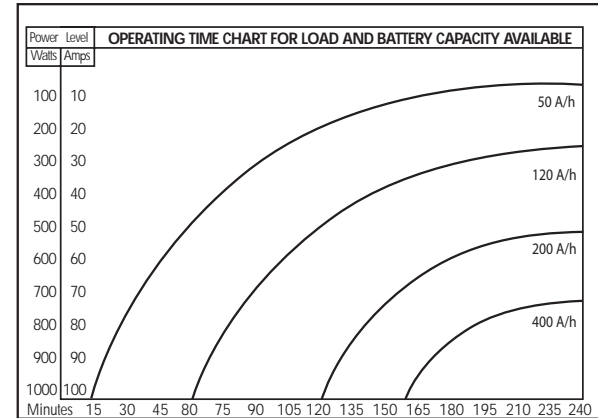

For example, as shown in the above graph, using a 400 A/h battery (batteries), if the average power usage will be 1000 watts, the operating time will be about 150 minutes. A larger capacity battery will deliver more operating time between recharges.

**Note:** The manufacturer recommends conservative estimates when selecting a battery. More amp hours will deliver a reserve capacity, and a larger capacity battery will not be subject to deep discharges. Ideally, the number of amp hours (A/h) you expect to use should be less than 50% of the battery's rated capacity.

## Protective Features

### LOW BATTERY ALARM

An audible alarm will sound when the 12 volt DC power supply voltage drops down to  $10.5 \pm 0.3$  volts. This indicates that the battery needs to be charged or there is an excessive voltage drop between the battery power source and the inverter.

**Notes:** It is normal for the alarm to sound when the inverter is being connected to, or disconnected from, a 12 volt DC power source. This does not indicate a problem. However, if this alarm sounds continuously, discontinue inverter operation and charge the battery before resuming operation. If the voltage drops to 10.0 volts DC, the inverter will automatically shut down.

If the low voltage alarm sounds when the battery is fully charged (refer to the "Fault Protection and Troubleshooting Guide" on pages 15).

### CIRCUIT PROTECTION

The inverter has electronic circuit protection against overload or short circuit conditions.

## **⚠ CAUTION**

If turning the ON/OFF Switch OFF then ON again does not reset the inverter, DO NOT ATTEMPT TO OPEN THE INVERTER. Opening the inverter for any reason will void the warranty. The unit must be returned to Vector Manufacturing for testing and repair by professional factory technicians.

## **INSTALLATION**

MAXX SST™ inverters will provide you with continuous electrical power when powered by a 12 volt DC source, such as a vehicle battery or a multiple battery configuration (see the diagram under “Battery Configuration,” page 6). This manual does not describe all of the possible configurations.

### **Operating Environment**

Do not locate inverters in an area, room or compartment where explosives or flammable fumes might be present, such as engine rooms, engine compartments, and boats or small, unvented battery compartments.

To avoid possible dangerous conditions, the inverters must be located where:

1. The unit is kept dry;
2. Air temperature is between 30°F (–1°C), non-condensing, and 105° F (40°C);
3. At least three inches of clearance from other objects is maintained for cooling airflow;
4. The unit is not exposed to direct heat, sunlight or to explosive or flammable fumes; and
5. The unit is as close to the DC power source as possible.

Never connect the chassis ground wire from the inverter to the DC negative input.

- CHECK to ensure that the combined loads of the appliances being powered by the inverter DO NOT continuously exceed the inverter’s wattage rating.
- NEVER place items on or over the inverter during operation

MAXX SST™ inverters generate heat during operation and must be placed where cool air can circulate to the internal fan, and hot air can be removed.

For optimum operation, the inverter should be placed or mounted on a flat surface; ideally, a normally cool metal surface to help diffuse the heat that is generated. Two cables (see the diagram on page 8) are not supplied, but will be required to allow for full power operation and to provide flexibility in positioning the inverter.

### **Marine Applications**

In all marine applications, DO NOT install the inverter below or near the waterline, and keep the inverter away from moisture and water.

Use ONLY non-corrosive marine fasteners and fittings for installation. Only connect the inverter’s DC input to existing wiring (which must be approved for marine use) at the appropriate gauge, cable and length (see the “Specifications” section, page 16). For cable lengths exceeding 6 feet from inverter to batteries, call Vector for additional installation information. The cable, fuse holder and fuse (not supplied) can be purchased at an electrical supply company. The fuse holder and fuse are a specified amperage rating (see Specifications, page 16). Call Vector Technical Support at (954) 584-4446 or toll-free at (866) 584-5504 with any questions.

## **Installation Procedures**

When wiring the inverter to a 12 volt DC power source, ensure that polarity is correct. Reversed polarity will blow a fuse and may cause permanent damage to the inverter. Review diagrams on page 2, if necessary, to identify the location of the DC terminals.

**Note:** *The manufacturer’s warranty does NOT cover damage due to reversed polarity.*

### **Quick Operational Test or Emergency Use**

You will need:

- A heavy-duty jumper cable set of the specified AWG wire rating (see the “Specifications” section, page 16)
- A fully-charged automobile battery
- A common slip joint plier for loosening and tightening terminal nuts

### **PROCEDURE**

1. Unscrew nuts in input terminal block.
2. Identify the positive and negative terminals on the 12 volt DC battery (or other 12 volt DC power source) and identify the positive and negative terminals on the inverter.
3. Using a set of heavy-duty jumper cables, attach the red cable to the inverter’s positive (+) terminal and the black cable to the inverter’s negative (–) terminal.
4. Connect the clamps on the other ends of the jumper cables to the corresponding positive (+) and negative (–) terminals on the 12 volt DC vehicle battery (or other 12 volt DC power source). There may be some minor sparking.
5. Turn the inverter ON/OFF Switch ON.
6. Plug in a lamp with a 100 watt light bulb and switch the lamp on. If the lamp works normally, the inverter is functioning properly and you can proceed to a permanent installation or continue to use the inverter with low wattage appliances. If the lamp does not light or does not work correctly:
  - A. Check all connections and tighten any that may be loose.
  - B. Ensure that the source battery has adequate charge.
  - C. If steps A and B do not correct the problem, contact Vector Technical Support, toll-free, at (866) 584-5504, for assistance.

### **Permanent Installation**

For permanent installation to heavy-duty battery power you will need:

- Two cables (as indicated in the “Specifications” section on page 16)
- Terminals to fit cable ends and stud terminals to inverter
- Hardware and battery connector to connect cables to the battery bank
- A single length of AWG cable multi-stranded, flexible, insulated cable (as indicated in the “Specifications” section on page 16) for chasis ground connection
- A holder and fuse (see “Specifications” on page 16)
- Mounting screws, bolts and nuts for mounting the inverter and fuse holder
- A drill for mounting the inverter and fuse holder
- Lead-tin solder, flux, propane torch and an igniter for the torch
- Wire stripper/cutting tool



## PRELIMINARY STEPS

The inverter has four slots in its mounting bracket that allow the unit to be fastened against a bulkhead, floor, wall or other flat surface. Ideally, the mounting surface should be cool to the touch. It is more efficient to use longer AC wiring than DC wiring, so install the inverter as close as possible to the 12 volt DC power source.

Vector inverters should be operated in horizontal position; if it is to be mounted on a wall, mount it horizontally so that indicators, switches, outlets and terminal blocks on the front panel are visible and accessible.

1. If inverter is to be installed in a vehicle, it is recommended that the unit be shock mounted to either the floor (in a clear, safe area) or on a secure flat surface.
2. Locate a convenient place to mount the inverter and fuse holder.
3. Perform a test routing of the proposed cable length, but don't do any cutting at this time (refer to the diagram on page 8 under "Battery Configuration").
4. Be sure that the positive (+) and negative (-) cables to the battery do not exceed six feet.
5. Using an appropriate AWG cable (see the diagram on page 8), reposition the inverter and fuse holder if necessary.
6. After you have performed the above preliminary installation steps, proceed with the actual inverter installation.

Contact the manufacturer for any further installation information or questions. You can purchase fuses, fuse holders, specific cable or cable battery connectors from your local electrical supplier or call Vector Technical Support, toll-free, at (866) 584-5504.

**Note:** *This procedure is for using locally purchased supplies. If a Vector Cable Set is used, follow the directions included with that set.*

## PERMANENT INSTALLATION PROCEDURE

The cables between the power source and inverter should be set up as illustrated in the diagram on page 8. Unscrew terminal nuts before beginning permanent installation. Proceed with DC cable and fuse installation as follows:

1. Ensure the inverter's ON/OFF Power Switch is in the OFF position.
2. Using tools and hardware, mount the inverter to a flat surface.
3. Ensure that mounting hardware does not touch any fuse holder or fuse contacts. Ensure that fuse is removed from its holder.
4. Measure the cable twice before cutting the cable.
5. Cut one cable length to connect the negative (-) battery terminal to the inverter's negative terminal, leaving a little slack in the cable.
6. Cut another cable to connect the positive (+) battery terminal to one side of fuse holder, leaving a little slack.
7. Cut the final cable to connect the other side of fuse holder to the inverter's positive (+) terminal.
8. Strip the end insulation of all three cables to 1-inch (2.45 cm).
9. Sweat-solder end ends of all cables. For safety, do this in an open space because it may require the use of a propane torch.
10. Connect one end of the negative (-) cable to a ring terminals\* going to the battery(ies).
11. Connect the short end of the positive (+) cable to a ring terminals\* going to the battery(ies).
12. Crimp or clamp ring terminals of the negative (-) and positive (+) cables (going to the battery), but do not connect the battery yet.

13. Connect the stripped, soldered (longer) end of the positive (+) cable to the red stud marked (+) on the inverter and tighten the retaining nut.
14. Connect the stripped, soldered end of the negative (-) cable to the black stud marked (-) on the inverter and tighten the retaining nut.
15. Connect the other (long) end of the (+) positive cable to one terminal of the heavy-duty fuse holder.
16. Connect the other conductor of the heavy-duty fuse holder to the (short) positive (+) battery terminal.
17. Connect the other end of the (-) negative cable with the ring terminal to the negative (-) battery terminal.
18. Connect an insulated wire (at least #12 AWG) between the chassis grounding screw on the inverter's case and a solid electrical ground to minimize possible electrical noise in TVs and radios. **Do not connect this wire to the negative DC input terminal.**
19. Ensure that all electrical connections have been tightened.
20. Ensure that the inverter's ON/OFF Switch is in the OFF position.
21. Insert the fuse into the fuse holder. There may be some sparking.
22. Ensure the 12 volt DC power source has an adequate charge.
23. Turn the inverter ON and apply a test load to the 120 volt AC outlets.

\* *Ring terminals are not included and must be supplied by user.*

If, after following all of the above steps, the inverter does not perform properly, the source voltage may be too low or the cables may be too long (or the gauge too light). Having checked and, if necessary, corrected these conditions, contact Vector Technical Support, toll-free, at (866) 584-5504 for assistance if problems persist.

## Connection To Load

The Power Inverter is equipped with standard North American three-prong type outlets. Plug the cord from the equipment you wish to operate into the AC outlet(s). Make sure the combined load requirement of your equipment does not exceed maximum continuous power.

The Power Inverter is engineered to be connected directly to standard electrical and electronic equipment in the manner described above. Do not connect the Power Inverter to household or RV AC distribution wiring. Do not connect the Power Inverter to any AC load circuit in which the neutral conductor is connected to ground (earth) or to the NEGATIVE of the DC (battery) source.

## **⚠ WARNING**

**Do not connect to AC distribution wiring!**

## Operating Tips

For best operating results, the inverter should be placed on a stable, flat surface. The inverter should only be used in locations that meet the following criteria:

**DRY** — Do not allow water or other liquids to come into contact with the inverter.

**COOL** — Surrounding air temperature should be between -0°C and 40°C — ideally between 15°C and 25°C (60-80°F). Keep the inverter away from direct sunlight, when possible.

**WELL-VENTILATED** — Keep the area surrounding the inverter clear to ensure free air circulation around the unit. Do not place items on or over the inverter during operation. The unit will shut down if the internal temperature gets too hot.

SAFE — Do not use the inverter near flammable materials or in any locations that may accumulate flammable fumes or gases. This is an electrical appliance that can briefly spark when electrical connections are made or broken.

## ⚠ CAUTION

### Rechargeable Devices

**Certain rechargeable devices do not operate well from a modified sine wave inverter. They only operate properly from a standard household outlet, which provides a pure sine wave. Therefore, the manufacturer recommends that these types of devices be operated from a standard household outlet only, not from the inverter.**

**This problem does not occur with most battery-operated equipment. Most of these devices use a separate charger or transformer that is plugged into an AC receptacle. The Power Inverter is easily capable of running most chargers and transformers.**

### Notes on Using the Remote Control (sold separately)

For ease of use, Vector offers (as a separate item) a Remote Control specifically designed for this line of MAXX SST inverters. The inverter ON/OFF Switch must be in the OFF position when connecting the Remote Control to the unit or the Remote Control will not operate. Once the unit has been turned ON using the Remote Control, inverter operation will continue to be controlled through the Remote Control. Turn the inverter OFF before disconnecting the Remote Control.

For more information about attaching and using the Remote Control, please refer to the Remote Control User's Manual.

## CARE AND MAINTENANCE

### Storage

1. Ideal storage temperature range is 50-68°F (10-20°C).
2. Store and use the inverter in a cool, dry place with adequate ventilation.
3. Avoid locations that are exposed to heating units, radiators, direct sunlight or excessive humidity or dampness.

### Fuse Replacement

This inverter is equipped with multiple internal fuses. Normally, these fuses will not “blow” unless there is a serious problem inside the unit. **Internal fuses are replaceable; however, only trained personnel should attempt fuse replacement.** If the unit is damaged during fuse replacement, the warranty may be voided. The manufacturer recommends contacting Technical Support, toll-free, at (866) 584-5504.

### Preventive Maintenance

Inverters require minimal maintenance. For optimum performance, the manufacturer recommends periodically performing the following preventive maintenance.

1. Turn OFF the inverter using the front panel ON/OFF Power Switch.
2. Remove the DC power fuse.
3. Check and tighten all electrical connections, including the ground.
4. Using a non-metallic vacuum cleaner hose, vacuum the air slots and fan area.
5. Clean the outside of the unit using a damp (not wet) cloth.
6. Wipe unit surfaces thoroughly with a dry cloth.
7. Re-insert the fuse and resume operation.

## TROUBLESHOOTING

### Common Audio/Visual Problems

#### “Buzzing” sound in audio systems

Some inexpensive stereo systems and “boom boxes” emit a buzzing sound from their speakers when operated from the Power Inverter. This occurs because the power supply in the electronic device does not adequately filter the modified sine wave produced by the inverter. The only solution to this problem is to use a higher quality sound system that incorporates a higher quality power amplified supply.

#### Television Interference

The Inverter is shielded to minimize interference with TV signals. However, in some instances, some interference may still be visible, particularly with weak TV signals. Try the following corrective measures:

- Position the inverter as far as possible from the television, the antenna and the antenna cables. Use an extension cable, if necessary.
- Adjust the orientation of the inverter, the antenna cables and the TV power cord to minimize interference.
- Make sure the antenna feeding the television provides an adequate (“snow free”) signal and that high quality, shielded antenna cable is used.
- Do not use the inverter to operate high-power appliances or tools at the same time you are using it to operate the TV.
- Make sure the inverter’s case is properly grounded (see “Permanent Installation Procedure” on page 12).

### Resetting the Unit

After over-voltage or thermal automatic shutdown, the VEC049D and VEC053D will reset automatically. To reset all other units, turn the ON/OFF Power Switch to the “OFF” position, then back “ON.”

## Fault Protection and Troubleshooting Guide

INVERTER POWER SWITCH TURNED ON

Trouble/Indication	Possible Cause	Suggested Remedy
No AC output — red LED lit	DC input is below 10 volts	Recharge or replace battery.
	Excessive appliance load — thermal shutdown	Turn unit OFF. Reduce the load, wait for the inverter to cool down, then turn the unit ON again.
No AC output — green LED not lit	Fuse(s) open	Check DC input — fuse(s) in vehicle. Replace the fuse with one of the same type and rating if necessary.
Low battery alarm sounds continuously	Low battery voltage	Recharge battery. Remove load from the inverter while recharging battery.
	Bad connection or wiring	Tighten all DC connections.
Motorized power tool will not start	Excessive start-up load	If appliance does not start, appliance is drawing excessive voltage and will not work with inverter.
Motorized power tool does not operate at correct speed	Purely inductive load	Make the load not purely inductive. Operate an incandescent lamp at the same time as motor.
Television/radio interference	Snow in picture, “buzzing” sound	Keep inverter and antenna distant from each other. Use shielded antenna. Connect antenna to amplifier.

## Free Manuals Download Website

<http://myh66.com>

<http://usermanuals.us>

<http://www.somanuals.com>

<http://www.4manuals.cc>

<http://www.manual-lib.com>

<http://www.404manual.com>

<http://www.luxmanual.com>

<http://aubethermostatmanual.com>

Golf course search by state

<http://golfingnear.com>

Email search by domain

<http://emailbydomain.com>

Auto manuals search

<http://auto.somanuals.com>

TV manuals search

<http://tv.somanuals.com>