

Operator's Manual

Vibratory Rammer

BS 50-4s, BS 50-4As
BS 60-4s, BS 60-4As
BS 70-4As

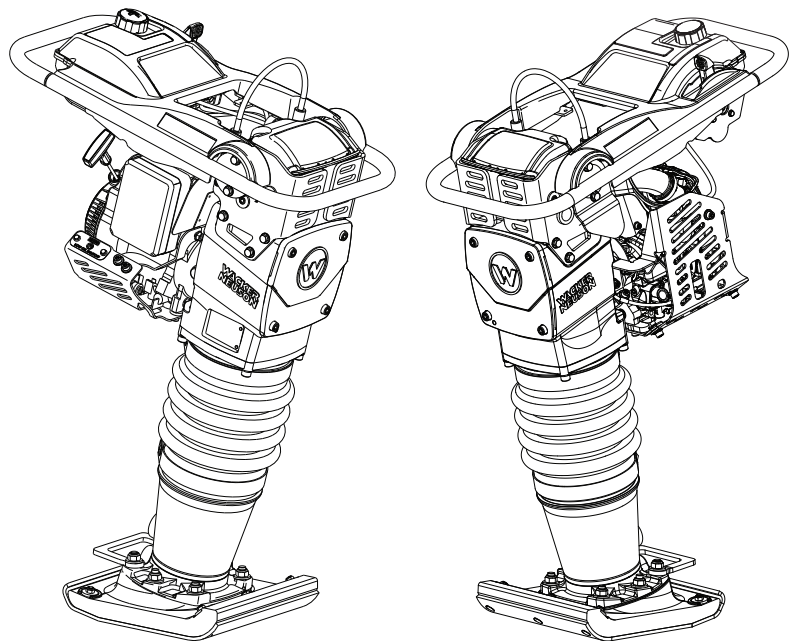

Type	BS 50-4s, BS 50-4As, BS 60-4s, BS60-4As, BS 70-4As
Document	5200015017
Date	0515
Version	05
Language	EN



Copyright notice

© Copyright 2015 by Wacker Neuson Production Americas LLC

All rights, including copying and distribution rights, are reserved.

This publication may be photocopied by the original purchaser of the machine. Any other type of reproduction is prohibited without express written permission from Wacker Neuson Production Americas LLC.

Any type of reproduction or distribution not authorized by Wacker Neuson Production Americas LLC represents an infringement of valid copyrights. Violators will be prosecuted.

Trademarks

All trademarks referenced in this manual are the property of their respective owners.

Manufacturer

Wacker Neuson Production Americas LLC

N92W15000 Anthony Avenue

Menomonee Falls, WI 53051 U.S.A.

Tel: (262) 255-0500 · Fax: (262) 255-0550 · Tel: (800) 770-0957

www.wackerneuson.com

Original instructions

This Operator's Manual presents the original instructions. The original language of this Operator's Manual is American English.

Foreword

SAVE THESE INSTRUCTIONS—This manual contains important instructions for the machine models below. These instructions have been written expressly by Wacker Neuson Production Americas LLC and must be followed during installation, operation, and maintenance of the machines.

Machine	Item Number
BS 50-4s, BS 50-4As	5200000644, 5200000662, 5200000679, 5200000680, 5200018226, 5200018219, 5100015099
BS 60-4s, BS 60-4As	5200000647, 5200000648, 5200000667, 5200000668, 5200000674, 5200000675, 5200014910, 5200018231, 5200018232, 5200018233, 5200022984, 5100015123
BS 70-4As	5100015124, 5100015126

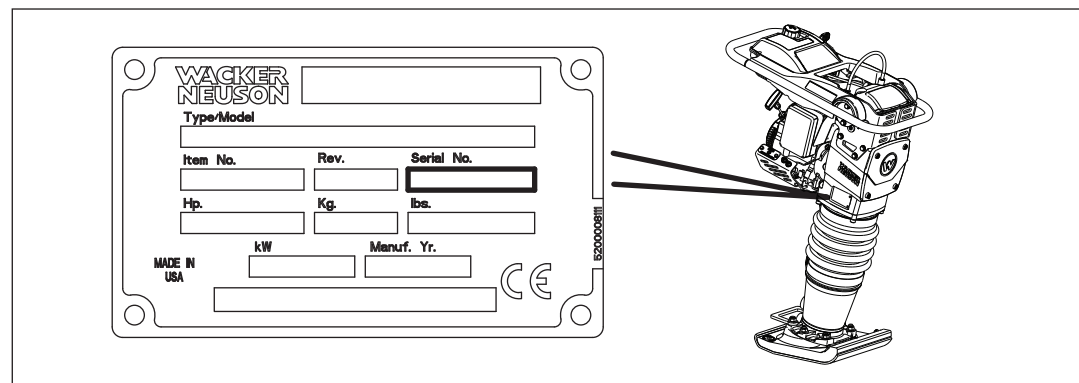

wc_gr011588

Machine identification

A nameplate listing the model number, item number, revision number, and serial number is attached to this machine. The location of the nameplate is shown above.

Serial number (S/N)

For future reference, record the serial number in the space provided below. You will need the serial number when requesting parts or service for this machine.

Serial Number:

Machine documentation

- From this point forward in this documentation, Wacker Neuson Production Americas LLC will be referred to as Wacker Neuson.
- Keep a copy of the Operator’s Manual with the machine at all times.
- When ordering parts or requesting service information, be prepared to provide the machine model number, item number, revision number, and serial number.

Important: For spare parts information, please see your Wacker Neuson Dealer, or visit the Wacker Neuson website at <http://www.wackerneuson.com/>.

Expectations for information in this manual

- This manual provides information and procedures to safely operate and maintain the above Wacker Neuson model(s). For your own safety and to reduce the risk of injury, carefully read, understand, and observe all instructions described in this manual.
 - Wacker Neuson expressly reserves the right to make technical modifications, even without notice, which improve the performance or safety standards of its machines.
 - The information contained in this manual is based on machines manufactured up until the time of publication. Wacker Neuson reserves the right to change any portion of this information without notice.
 - The illustrations, parts, and procedures in this manual refer to Wacker Neuson factory-installed components. Your machine may vary depending on the requirements of your specific region.
-

CALIFORNIA Proposition 65 Warning

Engine exhaust, some of its constituents, and certain vehicle components contain or emit chemicals known to the State of California to cause cancer and birth defects or other reproductive harm.

Laws pertaining to spark arresters

NOTICE: State Health Safety Codes and Public Resources Codes specify that in certain locations spark arresters be used on internal combustion engines that use hydrocarbon fuels. A spark arrester is a device designed to prevent accidental discharge of sparks or flames from the engine exhaust. Spark arresters are qualified and rated by the United States Forest Service for this purpose. In order to comply with local laws regarding spark arresters, consult the engine distributor or the local Health and Safety Administrator.

Manufacturer's approval

This manual contains references to *approved* parts, attachments, and modifications. The following definitions apply:

- **Approved parts or attachments** are those either manufactured or provided by Wacker Neuson.
- **Approved modifications** are those performed by an authorized Wacker Neuson service center according to written instructions published by Wacker Neuson.
- **Unapproved parts, attachments, and modifications** are those that do not meet the approved criteria.

Unapproved parts, attachments, or modifications may have the following consequences:

- Serious injury hazards to the operator and persons in the work area
- Permanent damage to the machine which will not be covered under warranty

Contact your Wacker Neuson dealer immediately if you have questions about approved or unapproved parts, attachments, or modifications.



EC Declaration of Conformity

Manufacturer

Wacker Neuson Production Americas LLC, N92W15000 Anthony Avenue,
Menomonee Falls, Wisconsin 53051 USA

Product

Product	BS 50-4s
Product category	Vibratory Rammer
Product function	To compact soil
Item number	5200000662
Net installed power	2.4 kW
Measured sound power level	103 dB(A)
Guaranteed sound power level	108 dB(A)

Conformity Assessment Procedure

According to 2000/14/EC ANNEX VIII

Notified Body

Lloyds Register Verification Limited (Notified Body No 0038)
71 Fenchurch Street, London EC3M 4BS, United Kingdom

Directives and Standards

We hereby declare that this product meets and complies with the relevant regulations and requirements of the following directives and standards:

2006/42/EC, 2000/14/EC, 2005/88/EC, 2004/108/EC, EN 500-1, EN 500-4

Authorized Person for Technical Documents

Leo Goeschka, Wacker Neuson Produktion GmbH & Co. KG, Preußenstraße 41,
80809 München

Menomonee Falls, WI, USA,

20.02.2015

Keith Herr
Managing Director
For Wacker Neuson

Dan Domanski
Technical Director
For Wacker Neuson

Paul Sina
Manager, Product Engineering
For Wacker Neuson



EC Declaration of Conformity

Manufacturer

Wacker Neuson Production Americas LLC, N92W15000 Anthony Avenue,
Menomonee Falls, Wisconsin 53051 USA

Product

Product	BS 50-4As	
Product category	Vibratory Rammer	
Product function	To compact soil	
Item number	5200018219	5100015099
Net installed power	2.35 kW	2.70 kW
Measured sound power level	103 db(A)	104 db(A)
Guaranteed sound power level	108 db(A)	

Conformity Assessment Procedure

According to 2000/14/EC ANNEX VIII

Notified Body

Lloyds Register Verification Limited (Notified Body No 0038)
71 Fenchurch Street, London EC3M 4BS, United Kingdom

Directives and Standards

We hereby declare that this product meets and complies with the relevant regulations and requirements of the following directives and standards:

2006/42/EC, 2000/14/EC, 2005/88/EC, 2004/108/EC, EN 500-1, EN 500-4

Authorized Person for Technical Documents

Leo Goeschka, Wacker Neuson Produktion GmbH & Co. KG, Preußenstraße 41,
80809 München

Menomonee Falls, WI, USA, 29.04.2015

Keith Herr
Managing Director
For Wacker Neuson

Dan Domanski
Technical Director
For Wacker Neuson

Paul Sina
Manager, Product Engineering
For Wacker Neuson

Original Declaration of Conformity



EC Declaration of Conformity

Manufacturer

Wacker Neuson Production Americas LLC, N92W15000 Anthony Avenue,
Menomonee Falls, Wisconsin 53051 USA

Product

Product	BS 60-4s
Product category	Vibratory Rammer
Product function	To compact soil
Item number	5200000667, 5200000675, 5200000674, 5200000668
Net installed power	2.4 kW
Measured sound power level	103 dB(A)
Guaranteed sound power level	108 dB(A)

Conformity Assessment Procedure

According to 2000/14/EC ANNEX VIII

Notified Body

Lloyds Register Verification Limited (Notified Body No 0038)
71 Fenchurch Street, London EC3M 4BS, United Kingdom

Directives and Standards

We hereby declare that this product meets and complies with the relevant regulations and requirements of the following directives and standards:

2006/42/EC, 2000/14/EC, 2005/88/EC, 2004/108/EC, EN 500-1, EN 500-4

Authorized Person for Technical Documents

Leo Goeschka, Wacker Neuson Produktion GmbH & Co. KG, Preußenstraße 41,
80809 München

Menomonee Falls, WI, USA, 20.02.2015

Keith Herr
Managing Director
For Wacker Neuson

Dan Domanski
Technical Director
For Wacker Neuson

Paul Sina
Manager, Product Engineering
For Wacker Neuson



EC Declaration of Conformity

Manufacturer

Wacker Neuson Production Americas LLC, N92W15000 Anthony Avenue,
Menomonee Falls, Wisconsin 53051 USA

Product

Product	BS 60-4As	
Product category	Vibratory Rammer	
Product function	To compact soil	
Item number	5200018232, 5200018233	5100015123
Net installed power	2.35 kW	2.7 kW
Measured sound power level	104 db(A)	
Guaranteed sound power level	108 db(A)	

Conformity Assessment Procedure

According to 2000/14/EC ANNEX VIII

Notified Body

Lloyds Register Verification Limited (Notified Body No 0038)
71 Fenchurch Street, London EC3M 4BS, United Kingdom

Directives and Standards

We hereby declare that this product meets and complies with the relevant regulations and requirements of the following directives and standards:

2006/42/EC, 2000/14/EC, 2005/88/EC, 2004/108/EC, EN 500-1, EN 500-4

Authorized Person for Technical Documents

Leo Goeschka, Wacker Neuson Produktion GmbH & Co. KG, Preußenstraße 41,
80809 München

Menomonee Falls, WI, USA, 29.04.2015

Keith Herr
Managing Director
For Wacker Neuson

Dan Domanski
Technical Director
For Wacker Neuson

Paul Sina
Manager, Product Engineering
For Wacker Neuson



EC Declaration of Conformity

Manufacturer

Wacker Neuson Production Americas LLC, N92W15000 Anthony Avenue,
Menomonee Falls, Wisconsin 53051 USA

Product

Product	BS 70-4As
Product category	Vibratory Rammer
Product function	To compact soil
Item number	5100015124
Net installed power	2.7 kW
Measured sound power level	104 db(A)
Guaranteed sound power level	108 db(A)

Conformity Assessment Procedure

According to 2000/14/EC ANNEX VIII

Notified Body

Lloyds Register Verification Limited (Notified Body No 0038)
71 Fenchurch Street, London EC3M 4BS, United Kingdom

Directives and Standards

We hereby declare that this product meets and complies with the relevant regulations and requirements of the following directives and standards:

2006/42/EC, 2000/14/EC, 2005/88/EC, 2004/108/EC, EN 500-1, EN 500-4

Authorized Person for Technical Documents

Leo Goeschka, Wacker Neuson Produktion GmbH & Co. KG, Preußenstraße 41,
80809 München

Menomonee Falls, WI, USA, 29.04.2015

Keith Herr
Managing Director
For Wacker Neuson

Dan Domanski
Technical Director
For Wacker Neuson

Paul Sina
Manager, Product Engineering
For Wacker Neuson

Foreword	3
EC Declaration of Conformity	5
1 Safety Information	17
1.1 Signal Words Used in this Manual	17
1.2 Machine Description and Intended Use	18
1.3 Safety Guidelines for Operating the Machine	19
1.4 Safety Guidelines for Lifting the Machine	20
1.5 Service Safety	21
1.6 Operator Safety while Using Internal Combustion Engines	23
2 Labels	24
2.1 Label Locations	24
2.2 Label Meanings	25
3 Lifting and Transporting	29
3.1 Lifting the Rammer	29
3.2 Transporting the Rammer	30
4 Operation	33
4.1 Preparing the Machine for First Use	33
4.2 Recommended Fuel	33
4.3 Refueling the Machine	34
4.4 Position of the Operator	35
4.5 Before Starting	35
4.6 Starting, Operating, and Stopping the Machine—WM 100	36
4.7 Starting, Operating, and Stopping the Machine—Honda	38
4.8 Low Oil Shut-Off Switch—WM100	40
4.9 Low Oil Shut-Off Switch—Honda	41
4.10 Emergency Shutdown Procedure	41
4.11 Optional Equipment	42
5 Maintenance	43
5.1 Maintaining the Emission Control System	43
5.2 Periodic Maintenance Schedule	44
5.3 Servicing the Air Cleaner	45

5.4	Checking the Fuel Lines and Fittings	46
5.5	Maintaining the Shoe Hardware	47
5.6	Inspecting the Machine	48
5.7	Cleaning the Engine Cooling Fins	49
5.8	Cleaning and Checking the Spark Plug	50
5.9	Checking and Changing the Engine Oil	51
5.10	Checking and Changing the Ramming System Oil	53
5.11	Inspecting and Cleaning the Fuel Filter	55
5.12	Replacing the In-Line Fuel Filter Assembly	56
5.13	Long-Term Storage	57
5.14	Machine Disposal / Decommissioning	58
6	Troubleshooting	59
7	Technical Data	60
7.1	BS 50-4s	60
7.2	BS 50-4As	61
7.3	BS 60-4s	62
7.4	BS 60-4As	63
7.5	BS 70-4As	64
7.6	Sound Measurements	65
7.7	Vibration Measurements	66
7.8	Dimensions	67
8	Emission Control Systems Information and Warranty—Gasoline	69
8.1	Emission Control System Background Information	69
8.2	Limited Defect Warranty for Exhaust Emission Control System	70
8.3	Limited Defect Warranty for Wacker Neuson Evaporative Emission Control Systems	70

1 Safety Information

1.1 Signal Words Used in this Manual

This manual contains DANGER, WARNING, CAUTION, *NOTICE*, and NOTE signal words which must be followed to reduce the possibility of personal injury, damage to the equipment, or improper service.



This is the safety alert symbol. It is used to alert you to potential personal hazards.

- ▶ Obey all safety messages that follow this symbol.



DANGER

DANGER indicates a hazardous situation which, if not avoided, will result in death or serious injury.

- ▶ To avoid death or serious injury from this type of hazard, obey all safety messages that follow this signal word.



WARNING

WARNING indicates a hazardous situation which, if not avoided, could result in death or serious injury.

- ▶ To avoid possible death or serious injury from this type of hazard, obey all safety messages that follow this signal word.



CAUTION

CAUTION indicates a hazardous situation which, if not avoided, could result in minor or moderate injury.

- ▶ To avoid possible minor or moderate injury from this type of hazard, obey all safety messages that follow this signal word.

NOTICE: Used without the safety alert symbol, NOTICE indicates a situation which, if not avoided, could result in property damage.

Note: *A Note contains additional information important to a procedure.*

1.2 Machine Description and Intended Use

This machine is a vibratory rammer. The Wacker Neuson Rammer consists of a gasoline or diesel engine, a clutch, a fuel tank, a spring-loaded ramming system, a ramming shoe, and a handle. The engine transmits power through the ramming system and ramming shoe, generating percussive impact force to compact soil. The operator guides and controls the machine from behind using the handle.

This machine is intended to be used for compacting cohesive, mixed, and granular soils in confined areas.

This machine has been designed and built strictly for the intended use described above. Using the machine for any other purpose could permanently damage the machine or seriously injure the operator or other persons in the area. Machine damage caused by misuse is not covered under warranty.

The following are some examples of misuse:

- Using the machine as a ladder, support, or work surface
 - Using the machine to carry or transport passengers or equipment
 - Using the machine as a hammer or for other demolition work
 - Attaching the machine to any other machine
 - Operating the machine outside of factory specifications
 - Operating the machine in a manner inconsistent with all warnings found on the machine and in the Operator's Manual
-

This machine has been designed and built in accordance with the latest global safety standards. It has been carefully engineered to eliminate hazards as far as practicable and to increase operator safety through protective guards and labeling. However, some risks may remain even after protective measures have been taken. They are called residual risks. On this machine, they may include exposure to:

- Heat, noise, exhaust, and carbon monoxide from the engine
- Fire hazards from improper refueling techniques
- Fuel and its fumes
- Personal injury from improper lifting techniques or operating techniques

To protect yourself and others, make sure you thoroughly read and understand the safety information presented in this manual before operating the machine.

1.3 Safety Guidelines for Operating the Machine

Operator training

Before operating the machine:

- Read and understand the operating instructions contained in all manuals delivered with the machine.
- Familiarize yourself with the location and proper use of all controls and safety devices.
- Contact Wacker Neuson for additional training if necessary.

When operating this machine:

- Do not allow improperly trained people to operate the machine. People operating the machine must be familiar with the potential risks and hazards associated with it.

Operator qualifications

Only trained personnel are permitted to start, operate, and shut down the machine. They also must meet the following qualifications:

- have received instruction on how to properly use the machine
- are familiar with required safety devices

The machine must not be accessed or operated by:

- children
- people impaired by alcohol or drugs

Application area

Be aware of the application area.

- Keep unauthorized personnel, children, and pets away from the machine.
- Remain aware of changing positions and the movement of other equipment and personnel in the application area/job site.
- Identify whether special hazards exist in the application area, such as toxic gases, or unstable ground conditions, and take appropriate action to eliminate the special hazards before using the machine.

Be aware of the application area.

- Do not operate the machine in areas that contain flammable objects, fuels, or products that produce flammable vapors.

Safety devices, controls, and attachments

Only operate the machine when:

- All safety devices and guards are in place and in working order.
- All controls operate correctly.
- The machine is set up correctly according to the instructions in the Operator's Manual.
- The machine is clean.
- The machine's labels are legible.

To ensure safe operation of the machine:

- Do not operate the machine if any safety devices or guards are missing or inoperative.
- Do not modify or defeat the safety devices.
- Only use accessories or attachments that are approved by Wacker Neuson.

Safe operating practices

When operating this rammer:

- Remain aware of the rammer's moving parts. Keep hands, feet, and loose clothing away from the rammer's moving parts.
- When working near the edges of pits, slopes, trenches, and platforms, always operate the rammer in such a way that there is no possibility of it tipping over or falling in.

When operating this rammer:

- Do not operate a rammer in need of repair.
- Do not tamper with or disable the function of the operating controls.
- Do not leave the rammer running unattended.
- Do not consume the operating fluids used in this machine. Depending on your machine model, these operating fluids may include water, wetting agents, fuel (gasoline, diesel, kerosene, propane, or natural gas), oil, coolant, hydraulic fluid, heat transfer fluid (propylene glycol with additives), battery acid, or grease.

Personal Protective Equipment (PPE)

Wear the following Personal Protective Equipment (PPE) while operating this machine:

- Close-fitting work clothes that do not hinder movement
- Safety glasses with side shields
- Hearing protection
- Safety-toed footwear

After use

- Stop the engine when the machine is not being operated.
- Close the fuel valve on engines equipped with one when the machine is not being operated.
- Ensure that the machine will not tip over, roll, slide, or fall when not being operated.
- Store the machine properly when it is not being used. The machine should be stored in a clean, dry location out of the reach of children.

1.4 Safety Guidelines for Lifting the Machine

When lifting the machine:

- Make sure slings, chains, hooks, ramps, jacks, forklifts, cranes, hoists, and any other type of lifting device used is attached securely and has enough weight-bearing capacity to lift or hold the machine safely. See section *Technical Data* for machine weight.
- Remain aware of the location of other people when lifting the machine.
- Only use the lifting points and tie-downs described in the Operator's Manual.
- Make sure the transporting vehicle has sufficient load capacity and platform size to safely transport the machine.

To reduce the possibility of injury:

- Do not stand under the machine while it is being lifted or moved.
- Do not get onto the machine while it is being lifted or moved.

1.5 Service Safety

Service training

Before servicing or maintaining the machine:

- Read and understand the instructions contained in all manuals delivered with the machine.
- Familiarize yourself with the location and proper use of all controls and safety devices.
- Only trained personnel shall troubleshoot or repair problems occurring with the machine.
- Contact Wacker Neuson for additional training if necessary.

When servicing or maintaining this machine:

- Do not allow improperly trained people to service or maintain the machine. Personnel servicing or maintaining the machine must be familiar with the associated potential risks and hazards.

Precautions

Follow the precautions below when servicing or maintaining the machine.

- Read and understand the service procedures before performing any service to the machine.
- All adjustments and repairs must be completed before operating the machine. Do not operate the machine with a known problem or deficiency.
- All repairs and adjustments shall be completed by a qualified technician.
- Turn off the machine before performing maintenance or making repairs.
- Remain aware of the machine's moving parts. Keep hands, feet, and loose clothing away from the machine's moving parts.
- Re-install the safety devices and guards after repair and maintenance procedures are complete.

Machine modifications

When servicing or maintaining the machine:

- Use only accessories/attachments that are approved by Wacker Neuson.

When servicing or maintaining the machine:

- Do not defeat safety devices.
- Do not modify the machine without the express written approval of Wacker Neuson.

Replacing parts and labels

- Replace worn or damaged components.
- Replace all missing and hard-to-read labels.
- When replacing electrical components, use components that are identical in rating and performance to the original components.
- When replacement parts are required for this machine, use only Wacker Neuson replacement parts or those parts equivalent to the original in all types of specifications, such as physical dimensions, type, strength, and material.

Cleaning

When cleaning and servicing the machine:

- Keep the machine clean and free of debris such as leaves, paper, cartons, etc.
- Keep the labels legible.

When cleaning the machine:

- Do not clean the machine while it is running.
- Never use gasoline or other types of fuels or flammable solvents to clean the machine. Fumes from fuels and solvents can become explosive.

Personal Protective Equipment (PPE)

Wear the following Personal Protective Equipment (PPE) while servicing or maintaining this machine:

- Close-fitting work clothes that do not hinder movement
- Safety glasses with side shields
- Hearing protection
- Safety-toed footwear

In addition, before servicing or maintaining the machine:

- Tie back long hair.
- Remove all jewelry (including rings).

Safe service practices

- Do not alter engine speeds. Run the engine only at speeds specified in *Technical Data*.
- Do not operate the machine without an air cleaner.
- Disconnect the spark plug before servicing to avoid accidental start-up.
- Do not crank a flooded engine with the spark plug removed. Fuel trapped in the cylinder will squirt out the spark plug opening.
- Do not test for spark if the engine is flooded or the smell of gasoline is present. A stray spark could ignite the fumes.

1.6 Operator Safety while Using Internal Combustion Engines



WARNING

Internal combustion engines present special hazards during operation and fueling. Failure to follow the warnings and safety standards could result in severe injury or death.

- ▶ Read and follow the warning instructions in the engine owner’s manual and the safety guidelines below.



DANGER

Exhaust gas from the engine contains carbon monoxide, a deadly poison. Exposure to carbon monoxide can kill you in minutes.

- ▶ NEVER operate the machine inside an enclosed area, such as a tunnel, unless adequate ventilation is provided through such items as exhaust fans or hoses.

Operating safety

When running the engine:

- Keep the area around the exhaust pipe free of flammable materials.
- Check the fuel lines and the fuel tank for leaks and cracks before starting the engine. Do not run the machine if fuel leaks are present or the fuel lines are loose.

When running the engine:

- Do not smoke while operating the machine.
- Do not run the engine near sparks or open flames.
- Do not touch the engine or muffler while the engine is running or immediately after it has been turned off.
- Do not operate a machine when its fuel cap is loose or missing.
- Do not start the engine if fuel has spilled or a fuel odor is present. Move the machine away from the spill and wipe the machine dry before starting.

Refueling safety

When refueling the engine:

- Clean up any spilled fuel immediately.
- Refill the fuel tank in a well-ventilated area.
- Re-install the fuel tank cap after refueling.
- Do not smoke.
- Do not refuel a hot or running engine.
- Do not refuel the engine near sparks or open flames.
- Use suitable tools for refueling (for example, a fuel hose or a funnel).
- Do not refuel if the machine is positioned in a truck fitted with a plastic bed liner. Static electricity can ignite the fuel or fuel vapors.

2 Labels

2.1 Label Locations

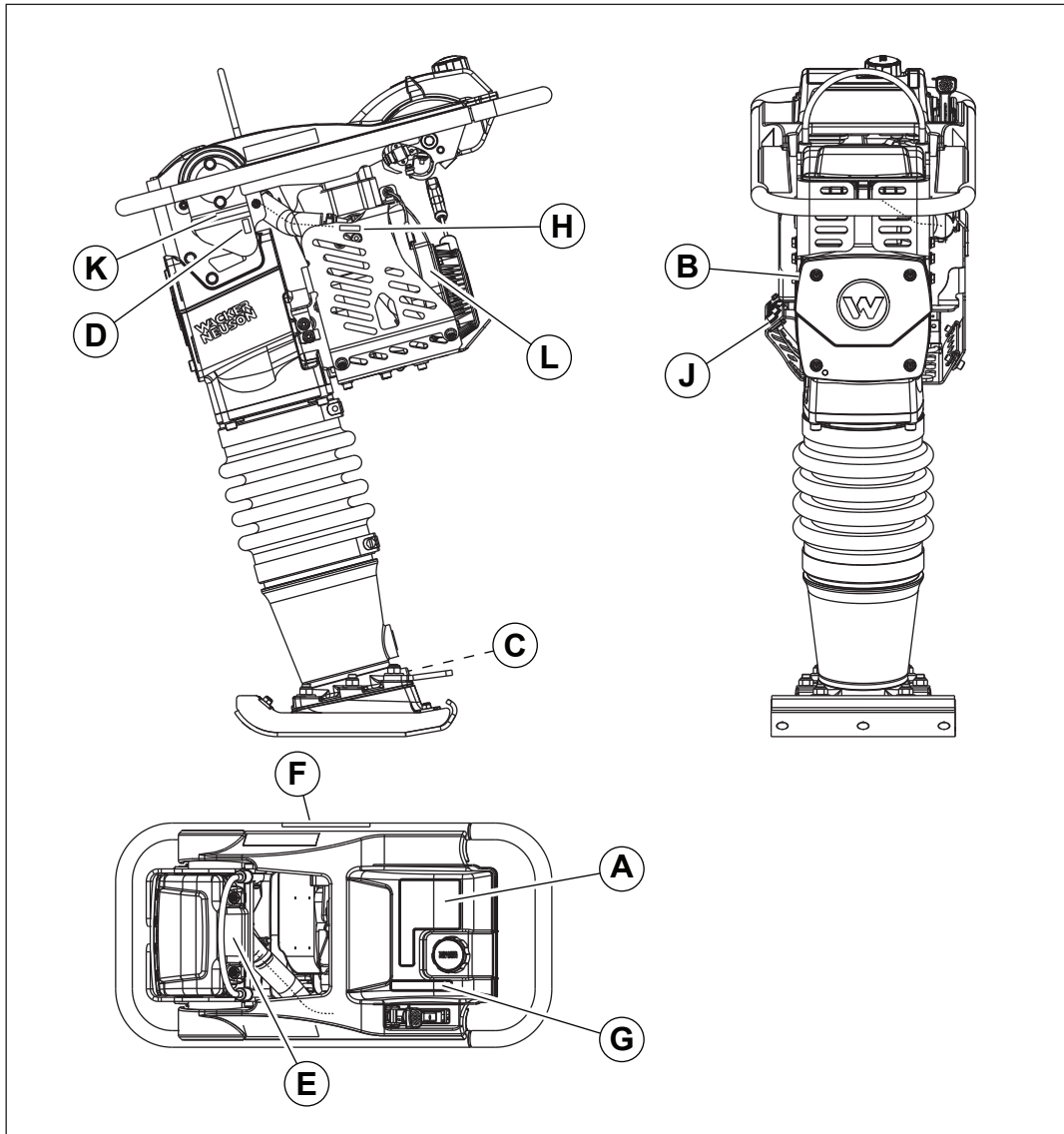

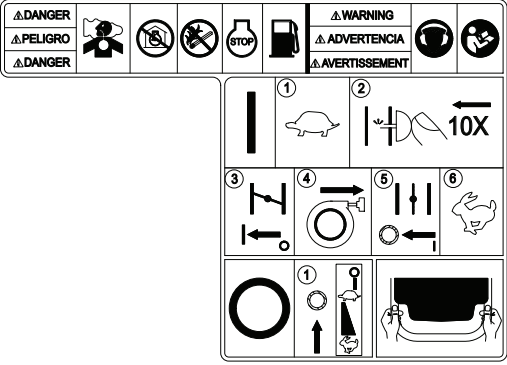
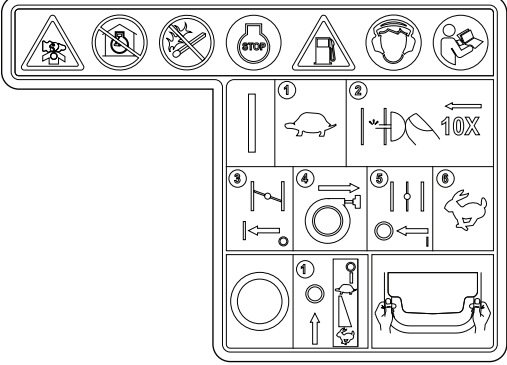

wc_gr010393

2.2 Label Meanings

<p>A</p>  <p style="text-align: right;">192884</p>  <p style="text-align: right;">192883</p>	<p>Danger Asphyxiation hazard.</p> <ul style="list-style-type: none"> ■ Engines emit carbon monoxide. ■ Do not run the machine indoors or in an enclosed area unless adequate ventilation, through such items as exhaust fans or hoses, is provided. ■ No sparks, flames, or burning objects near the machine. ■ Stop the engine before refueling. <p>Warning</p> <ul style="list-style-type: none"> ■ To reduce the risk of hearing loss, always wear hearing protection when operating this machine. ■ Read the Operator's Manual. <p>To start the machine:</p> <ol style="list-style-type: none"> 1. Move the throttle to the IDLE position. 2. Push the purge bulb 10 times. 3. Close the choke. 4. Pull the starter rope until engine starts. 5. Open the choke. 6. Move the throttle to the FAST position. <p>To stop the machine:</p> <ol style="list-style-type: none"> 1. Move the throttle past the SLOW position. <p>For optimal control, performance, and minimal hand/arm vibration, grasp handle as shown. Read the Operator's Manual.</p>
-----------------------------------------------------------------------------------------------------------------------------------------------------------------------------------------------------------------------------------------------------------------------------------------	-------------------------------------------------------------------------------------------------------------------------------------------------------------------------------------------------------------------------------------------------------------------------------------------------------------------------------------------------------------------------------------------------------------------------------------------------------------------------------------------------------------------------------------------------------------------------------------------------------------------------------------------------------------------------------------------------------------------------------------------------------------------------------------------------------------------------------------------------------------------------------------------------------------------------------------------------------------------------------------------------------------------------------------------------------------------------------------------------------------------------------------------------------------------------------------------------------------------------------------------

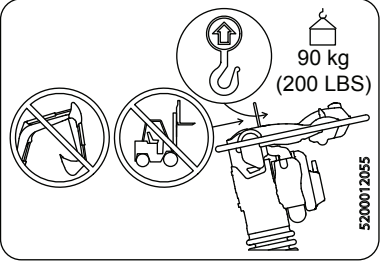
<p>B</p>	<p>178732</p> <p>WC_sy5200018773</p> <p>5200018772</p>	<p>WARNING Hot surface</p> <p>WM100</p> <p>Honda GX100</p>
<p>C</p>	<p>178792</p> <p>118839</p>	<p>WARNING Springs are compressed. Release cover slowly to avoid spring ejection. See the Repair Manual for proper disassembly instructions.</p>

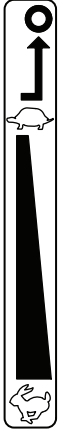
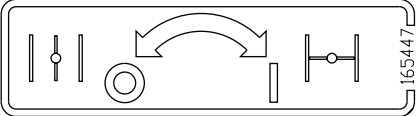
<p>D</p>		<p>Guaranteed sound power level in dB(A)</p>
<p>E</p>		<p>Lifting the rammer Use proper lifting device (crane or hoist) with proper lifting gear (hooks, slings and/or chains) to lift the rammer. Do not use the end of a boom or a fork lift tine to directly lift a rammer. Only lift the rammer by the lifting cable.</p>
<p>F</p>		<p>WARNING Operation of this equipment may create sparks that can start fires around dry vegetation. A spark arrester may be required. The operator should contact local fire agencies for laws or regulations relating to fire prevention requirements.</p>
<p>G</p>	 <p>5200000314</p>	<p>Turtle = Idle/slow engine speed Rabbit = Full/fast engine speed To stop the engine: From the idle position, push the throttle lever to the right, then forward to the OFF Position.</p>
<p>H</p>	 <p>165447</p>	<p>Choke: O = Open I = Closed</p>

<p>J</p>	<p>0164256</p> <p>0180779</p> <p>5200017492</p> <p>5200018534</p>	<p>This rammer is equipped with a low oil shutoff switch, it will not allow the engine to operate unless a sufficient amount of oil is present. See topic <i>Low Oil Shut-Off Switch</i>.</p> <p>WM 100</p> <p>Honda GX100 / GXR120</p>
<p>K</p>	<p>U.S.PAT.Nos.: 5720250, 5890834, 5934825, 6000879, 6390034, 6394697, 7303356, 7475665, 7498932, 7896575 OTHER U.S. AND FOREIGN PATENTS PENDING RAMMER/PLATE 159113</p>	<p>This machine may be covered by one or more patents.</p>
<p>L</p>	<p>5200015183XXXXX</p> <p>WACKER NEUSON Emission Control Information This Equipment Meets U.S. EPA / EVP Standards Using Certified Components DOM</p>	<p>Emission Control Information This equipment meets U.S. EPA EVAP standards.</p>

3 Lifting and Transporting

3.1 Lifting the Rammer

- Requirements**
- Lifting device (crane or hoist) capable of supporting the rammer's weight (see the identification plate on the rammer)
 - Lifting gear (hooks, slings, and/or chains) capable of supporting the rammer's weight
 - Engine stopped and cool to the touch

Procedure Perform the procedure below to lift the rammer.

1. Attach the lifting gear to the central lifting cable (a).

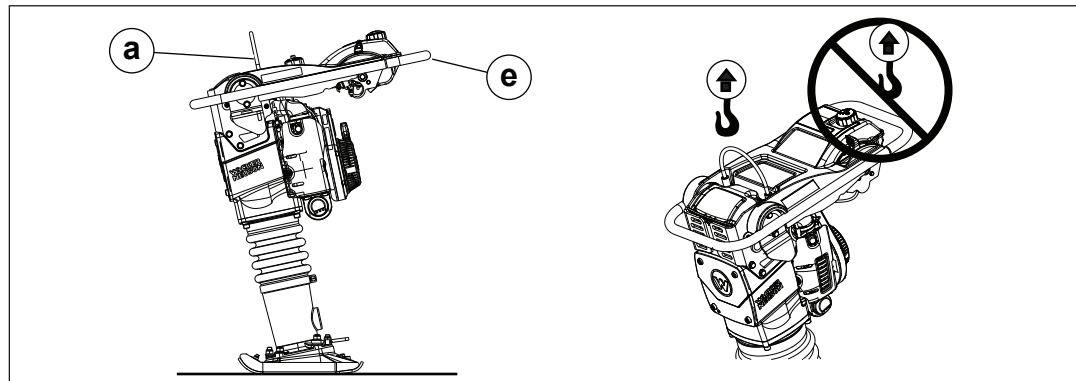

wc_gr010405



WARNING

Crushing hazard. Do not use the guide handle (e) to lift the rammer.

- ▶ Use only the central lifting cable to lift the rammer.



WARNING

Crushing hazard. Do not use the central lifting cable if there are any signs of cut wires, excessive wear, or other defects.

- ▶ Always inspect the central lifting cable for wear, damage, or abuse. Replace a damaged lifting cable immediately.
- ▶ Protect the central lifting cable from all sharp edges.

2. Lift the rammer a short distance, making sure that all connections are secure.
3. Continue lifting the rammer as required.

3.2 Transporting the Rammer

Overview This rammer can be transported in a vehicle, or manually, depending on job site conditions and distance to be traveled.

NOTICE: Do not tow this rammer.

Requirements

- Engine stopped and cool to the touch
- Lifting devices and gear
- Fuel tank drained (if transporting horizontally)

Transporting in a vehicle Perform the procedure below to transport the rammer in a vehicle.



WARNING

Lifting injury. This machine is too heavy to lift without mechanical assistance.

- ▶ Do not attempt to lift or carry the rammer without using appropriate lifting devices and gear as described in topic *Lifting the Rammer*.
-

1. Lift the rammer into the transport vehicle. See topic *Lifting the Rammer*.
2. Secure the rammer to the transport vehicle in the upright position to prevent it from tipping, falling, or rolling.

This procedure continues on the next page.

Continued from the previous page.

If the rammer cannot be secured in the upright position,

- a. Drain the fuel tank to prevent fuel from leaking from the cap **(c)**.
- b. Lay the rammer down only as shown and tie it to the vehicle at points **(a)** and **(b)**.

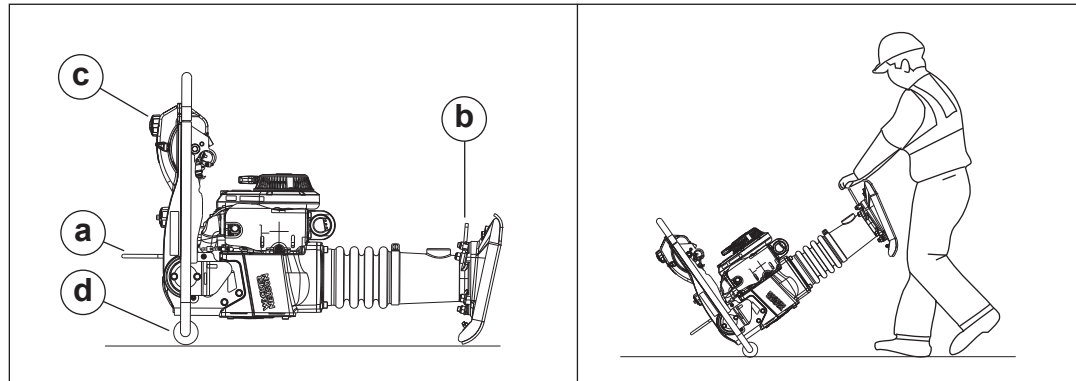

wc_gr010406

Transporting manually

Rollers **(d)** enable the rammer to be rolled from one location to another. Perform the procedure below to transport the rammer manually.

1. Drain the fuel tank to prevent fuel from leaking from the cap.
2. Lay the rammer down as shown.
3. Raise the rammer by the lifting handle **(b)**.
4. Roll the rammer forward or backward as needed.

Notes



4 Operation

4.1 Preparing the Machine for First Use

1. Make sure all loose packaging materials have been removed from the machine.
2. Check the machine and its components for damage. If there is visible damage, do not operate the machine! Contact your Wacker Neuson dealer immediately for assistance.
3. Take inventory of all items included with the machine and verify that all loose components and fasteners are accounted for.
4. Attach component parts not already attached.
5. Add fluids as needed, including fuel, engine oil, and ramming system oil.
6. Move the machine to its operating location.

4.2 Recommended Fuel

This engine is certified to operate on automotive unleaded gasoline. Use only fresh, clean gasoline. Gasoline containing water or dirt will damage fuel system.

Use of oxygenated fuels

Some conventional gasolines are blended with alcohol. These gasolines are collectively referred to as oxygenated fuels. If you use an oxygenated fuel, be sure it is unleaded and meets the minimum octane rating requirement.

Before using an oxygenated fuel, confirm the fuel's contents. Some states and provinces require this information to be posted on the fuel pump.

The following is the Wacker Neuson approved percentage of oxygenates:

ETHANOL - (ethyl or grain alcohol) 10% by volume. You may use gasoline containing up to 10% ethanol by volume (commonly referred to as E10). Gasoline containing more than 10% ethanol (such as E15, E20, or E85) may not be used because it could damage the engine.

If you notice any undesirable operating symptoms, try another service station, or switch to another brand of gasoline.

Fuel system damage or performance problems resulting from the use of an oxygenated fuel containing more than the percentages of oxygenates mentioned above are not covered under warranty.

4.3 Refueling the Machine

- Requirements**
- Machine shut down
 - Engine cool
 - Machine standing upright on the ramming shoe
 - Fresh, clean fuel supply

Procedure Perform the procedure below to refuel the machine.



WARNING

Fire and burn hazard. Fuel and its vapors are extremely flammable.

- ▶ Keep all sources of ignition away from the machine while refueling.
- ▶ Do not refuel if the machine is positioned in a truck fitted with a plastic bed liner. Static electricity can ignite the fuel or fuel vapors.
- ▶ Refuel only when the machine is outdoors.
- ▶ Clean up spilled fuel immediately.

1. Remove the fuel cap (a).

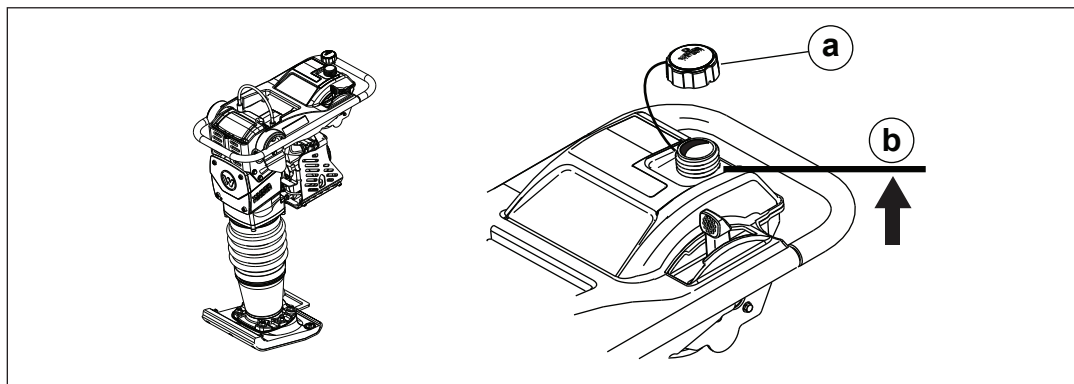

wc_gr010396

2. Fill the fuel tank until the fuel level reaches the bottom of the fuel tank neck (b).



CAUTION

Fire and health hazard. Fuel expands when heated. Expanding fuel in an over-filled tank can lead to spills and leaks.

- ▶ Do not overfill the fuel tank.

3. Re-install the fuel cap.

Result The machine has now been refueled.

4.4 Position of the Operator

For optimal control, performance, and minimal hand/arm vibration, follow the guidelines below when using the machine.

Grasp the handle with both hands as shown.

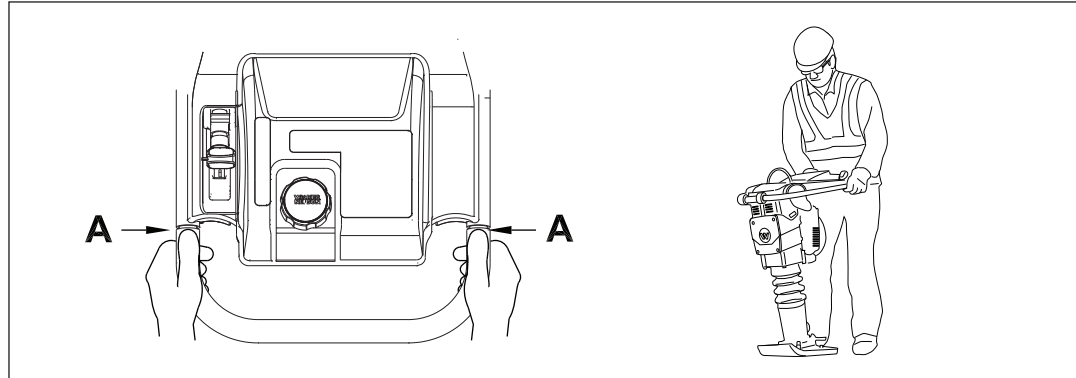

wc_gr011468

Stand behind the rammer, walking slowly and guiding the direction of travel as the machine moves forward.

Note: *Hand/Arm Vibration (HAV) has been optimized for the hand position shown. Reported HAV levels are measured at position A in conformance with EN 1033 and ISO 5349 standards.*

4.5 Before Starting

1. Read safety instructions at the beginning of this manual.
2. Make sure that the fuel tank is full.
3. Check engine oil level.
4. Check fuel lines and fittings.
5. Check the air filter.
6. Check the ramming system oil level.
7. Place rammer on loose soil or gravel. DO NOT start rammer on hard surfaces such as asphalt or concrete.

4.6 Starting, Operating, and Stopping the Machine—WM 100

- Requirements**
- Rammer is in serviceable condition and has been properly maintained
 - There is fuel in the tank

Starting the machine

Perform the procedure below to start the machine.

1. Move the throttle to the idle position (c2). This will automatically start the flow of fuel.

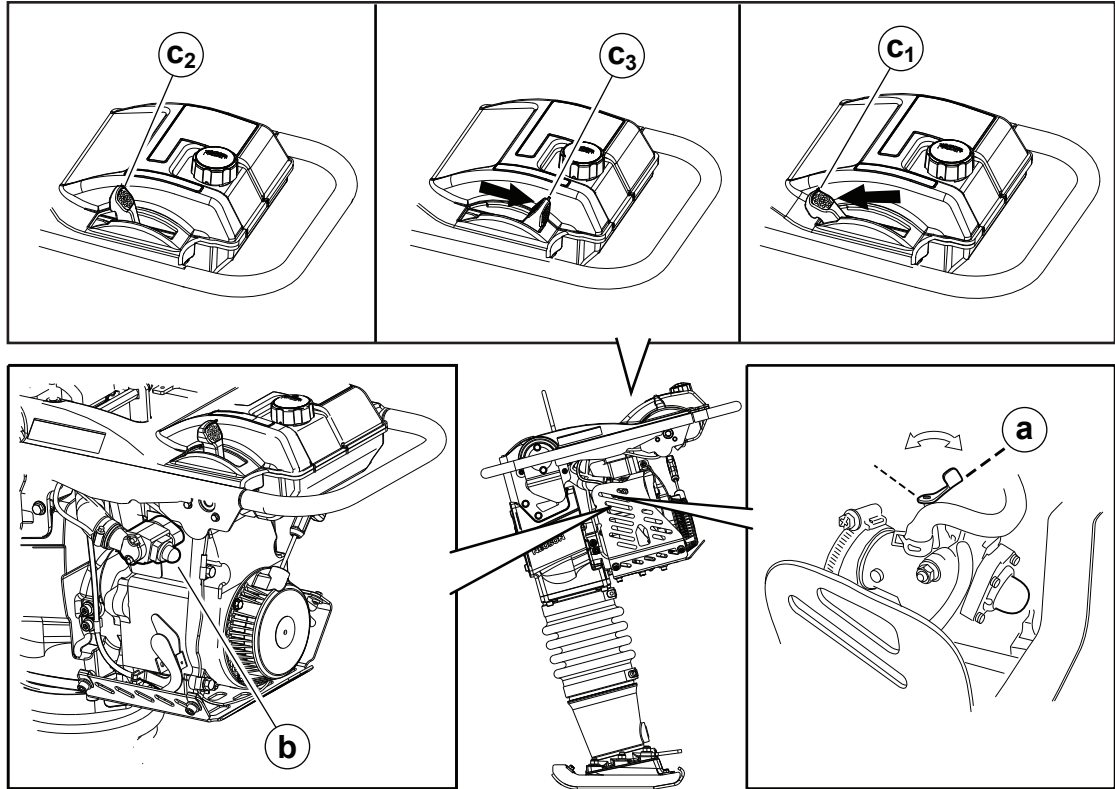

wc_gr011596

2. Close the choke (a).
3. Pump the purge bulb (b) 6 to 10 times or until you see fuel in the bulb.
Note: The engine will not become flooded by pumping the purge bulb more than 10 times. Pumping the purge bulb removes air from the fuel system. It does not pump fuel into the carburetor.

4. Pull the starter rope repeatedly until the engine starts.

Multiple pulls of the starter rope (usually fewer than five) may be required to start an engine:

- on a new machine being operated for the first time
- that has not been run for a long period of time (a week or more)
- that has been run completely out of fuel
- in cold weather conditions

This procedure continues on the next page.

Continued from the previous page.

Operating the machine

Perform the procedure below to operate the rammer.

1. Open the choke **(a)**.
2. Move the throttle to the full position **(c3)**.
3. Guide the rammer's direction of travel. Allow the rammer to pull itself forward. Do not try to overpower the rammer.



CAUTION

Do not lift or move the rammer to another location while it is operating. You may lose control of it.

- ▶ Stop the engine before lifting or moving the rammer to another location.
- ▶ Restart the engine only after the rammer is in place.

Safe operating practices

- For best compaction and shoe wear, the shoe must hit the ground flat **(d)**, not on its toe or heel.

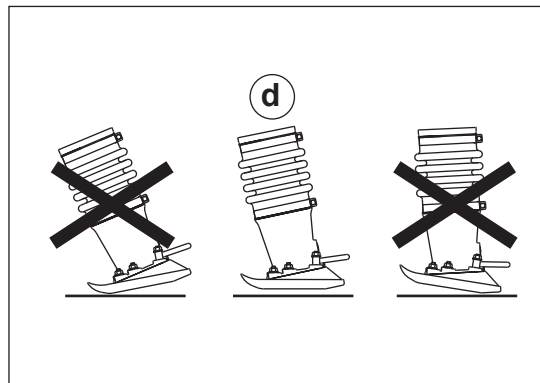

wc_gr008978

- Guide the rammer in such a way that you are not squeezed between the rammer and solid objects.
- Make sure you have solid footing when operating the rammer on uneven ground or when compacting coarse material.

Stopping the machine

1. Place the throttle in the idle position **(c2)**.

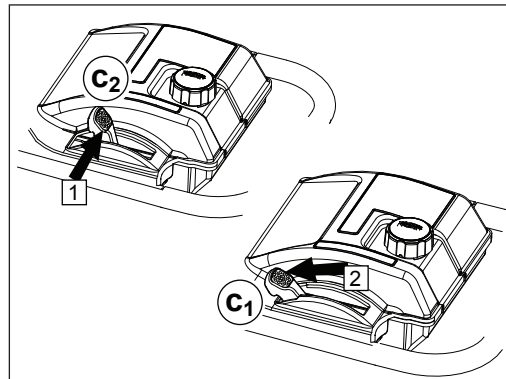

wc_gr011886

2. From the idle position, push the throttle to the right, then forward to the OFF position **(c1)**. The engine will stop and the fuel valve will close.

4.7 Starting, Operating, and Stopping the Machine—Honda

- Requirements**
- Rammer is in serviceable condition and has been properly maintained
 - There is fuel in the tank

Starting the machine

Perform the procedure below to start the machine.

1. Move the throttle to the idle position (**c2**). This will automatically start the flow of fuel.

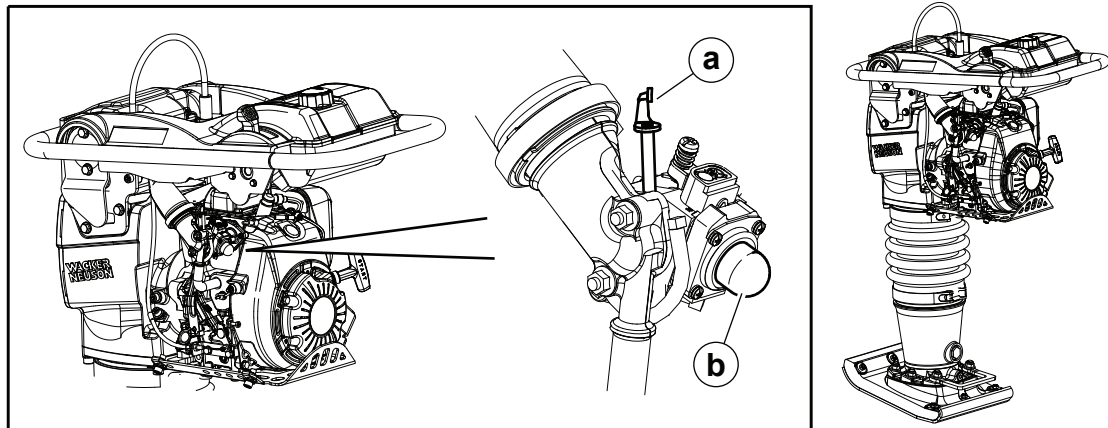
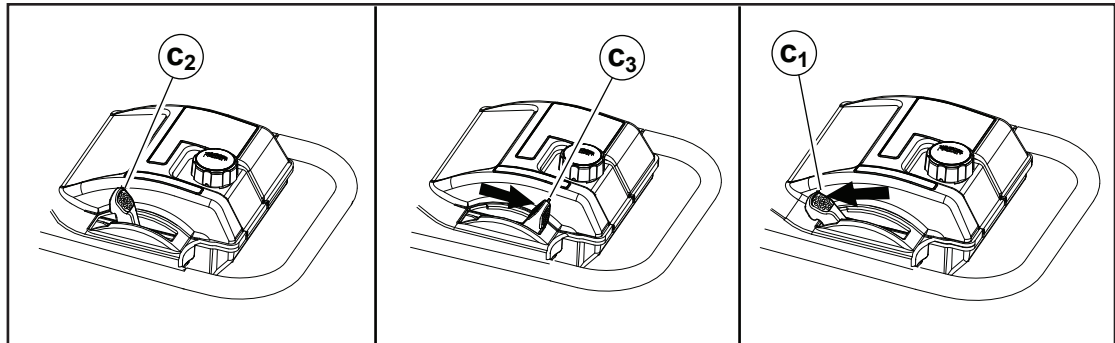

wc_gr011883

2. Close the choke (**a**).
3. Pump the purge bulb (**b**) 6 to 10 times or until you see fuel in the bulb.

Note: The engine will not become flooded by pumping the purge bulb more than 10 times. Pumping the purge bulb removes air from the fuel system. It does not pump fuel into the carburetor.

4. Pull the starter rope repeatedly until the engine starts.

Multiple pulls of the starter rope (usually fewer than five) may be required to start an engine:

- on a new machine being operated for the first time
- that has not been run for a long period of time (a week or more)
- that has been run completely out of fuel
- in cold weather conditions

This procedure continues on the next page.

Continued from the previous page.

Operating the machine

Perform the procedure below to operate the rammer.

1. Open the choke **(a)**.
2. Move the throttle to the full position **(c3)**.
3. Guide the rammer's direction of travel. Allow the rammer to pull itself forward. Do not try to overpower the rammer.



CAUTION

Do not lift or move the rammer to another location while it is operating. You may lose control of it.

- ▶ Stop the engine before lifting or moving the rammer to another location.
- ▶ Restart the engine only after the rammer is in place.

Safe operating practices

- For best compaction and shoe wear, the shoe must hit the ground flat **(d)**, not on its toe or heel.

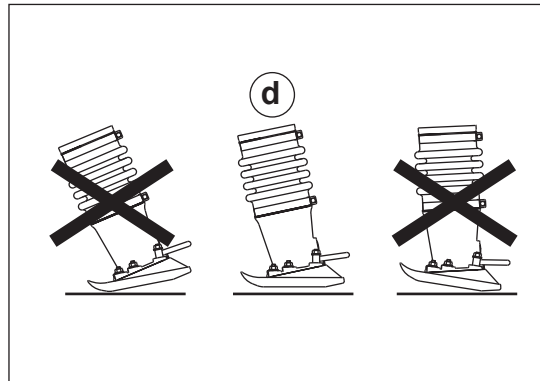

wc_gr008978

- Guide the rammer in such a way that you are not squeezed between the rammer and solid objects.
- Make sure you have solid footing when operating the rammer on uneven ground or when compacting coarse material.

Stopping the machine

1. Place the throttle in the idle position **(c2)**.

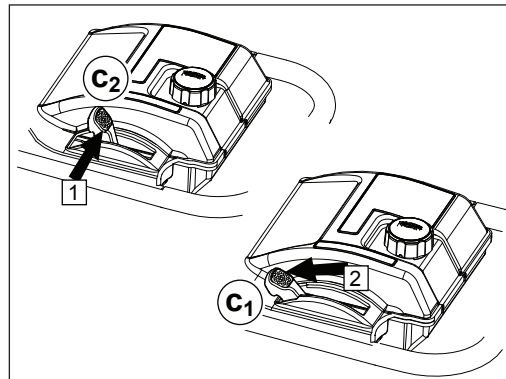

wc_gr011886

2. From the idle position, push the throttle to the right, then forward to the OFF position **(c1)**. The engine will stop and the fuel valve will close.

4.8 Low Oil Shut-Off Switch—WM100

Overview

The low oil shutoff switch is designed to prevent engine damage caused by an insufficient amount of oil. When the engine is started, an illuminated indicator (a) notifies the operator of the status of the engine oil level.

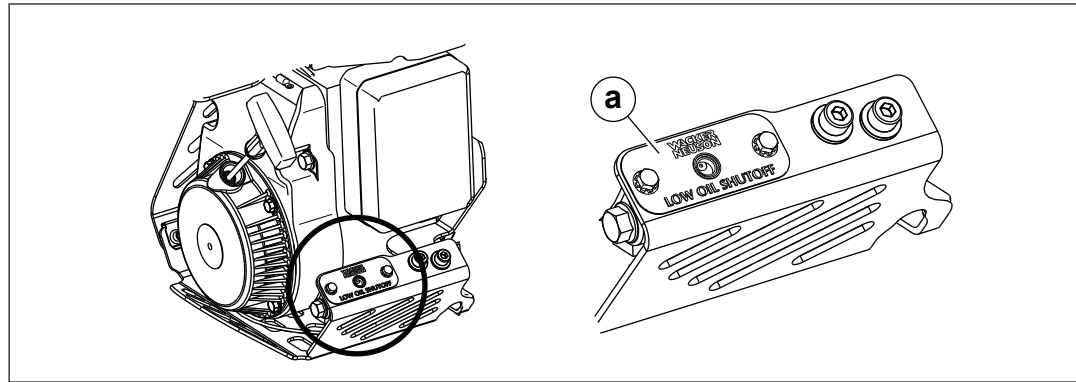

wc_gr011597

Condition	Engine oil level status	Required action
<ul style="list-style-type: none"> ■ Indicator flashes quickly once upon engine startup 	Engine oil level is acceptable	None
<ul style="list-style-type: none"> ■ Indicator flashes slowly ■ Engine starts, but stops after 10–15 seconds 	Engine oil level is low	Add engine oil. See <i>Technical Data</i> for quantity and type.
<ul style="list-style-type: none"> ■ Indicator illuminates and remains lit ■ Engine starts and continues to run 	Engine oil level is acceptable, but low oil shutoff switch is not functioning properly	Check connections on low oil shutoff switch. Replace the switch if indicator remains lit.
<ul style="list-style-type: none"> ■ Indicator does not flash upon engine startup ■ Engine starts and continues to run 	Low oil shutoff switch is not functioning properly	Check connections on low oil shutoff switch. Replace the switch if indicator still does not illuminate.

4.9 Low Oil Shut-Off Switch—Honda

Overview The low oil shutoff switch is designed to prevent engine damage caused by an insufficient amount of oil. When starting the engine, an illuminated indicator (a) notifies the operator that the engine oil level is low.

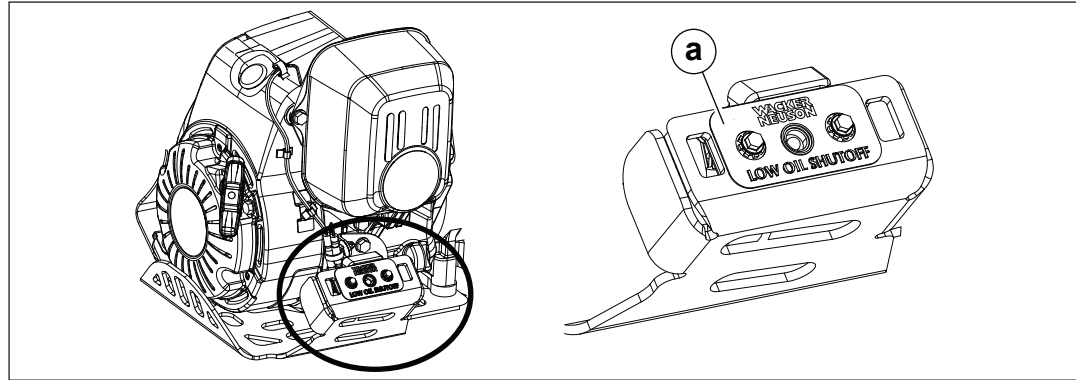

wc_gr011882

Condition	Engine oil level status	Required action
<ul style="list-style-type: none"> ■ Indicator does not flash and engine starts 	Engine oil level is acceptable	None
<ul style="list-style-type: none"> ■ Indicator flashes slowly ■ Engine does not start 	Engine oil level is low	Add engine oil. See <i>Technical Data</i> for quantity and type.

4.10 Emergency Shutdown Procedure

Procedure If a breakdown or accident occurs while the machine is operating, follow the procedure below:

1. Reduce engine speed to idle.
2. From the idle position, push the throttle to the right, then forward to the OFF position. The engine will stop and the fuel valve will close.
3. Contact the rental yard or machine owner for further instructions.

4.11 Optional Equipment

The following optional equipment is available:

- Foot extensions **(a)**—a narrow rammer foot for use in compacting trenches and in areas of limited clearance. Available sizes are 102 mm x 102 mm (4 in. x 4 in.) and 102 mm x 309 mm (4 in. x 12 in.).
- Wheel kit **(b)**—solid rubber tires joined to a steel axle, attached to the lifting handle by means of a slip-on retaining plate.

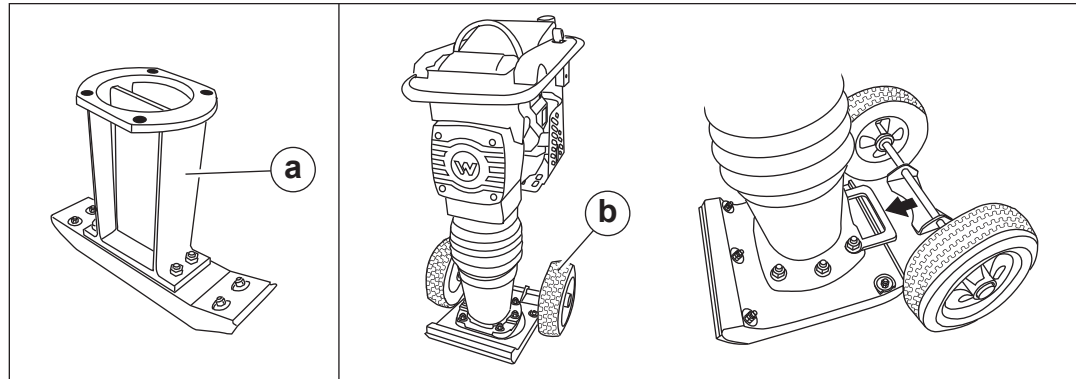

wc_gr008992

Contact your Wacker Neuson dealer for ordering information.

5 Maintenance



WARNING

A poorly maintained machine can malfunction, causing injuries or permanent damage to the machine.

- ▶ Keep the machine in safe operating condition by performing periodic maintenance and making repairs as needed.
-

5.1 Maintaining the Emission Control System

For machines sold in North America:

Normal maintenance, replacement, or repair of emission control devices and systems may be performed by any repair establishment or individual; however, warranty repairs must be performed by a dealer/service center authorized by Wacker Neuson. The use of service parts that are not equivalent in performance and durability to authorized parts may impair the effectiveness of the emission control system and may have a bearing on the outcome of a warranty claim.

5.2 Periodic Maintenance Schedule

The table below lists basic machine maintenance and engine maintenance. Refer to the engine manufacturer's owner's manual for additional information. Tasks designated with check marks may be performed by the operator. Tasks designated with square bullet points require special training and equipment.

	Daily before starting	After first 5 hours	Every week or 25 hours	Every month or 100 hours	Every 3 months or 300 hours	Every 5 months or 500 hours	Every year
Check engine oil.	✓						
Check and replace air filter as needed.	✓						
Check ramming system oil level in sightglass.	✓						
Check fuel line and fittings for cracks or leaks. Replace as needed.	■						
Tighten ramming shoe hardware.		■	■				
Inspect the machine.		✓	✓				
Clean engine cooling fins.			✓				
Clean and check spark plug gap.			■				
Change engine oil. ¹				■			
Change ramming system oil. ²					■		
Inspect central lifting cable for wear, damage, or abuse.					✓		
Replace in-line fuel filter assembly.						■	
Replace spark plug.						■	
Inspect and clean in-tank fuel filter.							✓

¹ Change engine oil after first 20 hours of operation.

² Change ramming system oil after first 50 hours of operation.

5.3 Servicing the Air Cleaner

When Inspect the air filter daily. Replace filter elements as needed.

- Requirements**
- Engine stopped and cool to the touch
 - Replacement filter elements (as needed)
 - Mild detergent
 - Warm water
 - Compressed air

NOTICE: Do not run the engine without the main paper air filter **(b)**. Severe engine damage will occur.



WARNING

Explosion and fire hazards.

- ▶ Never use gasoline or other types of low flash point solvents for cleaning the air filter. Use only compressed air, mild detergent, and warm water.

Procedure Perform the procedure below to clean the filter elements.

1. Remove the air cleaner cover **(a)**.

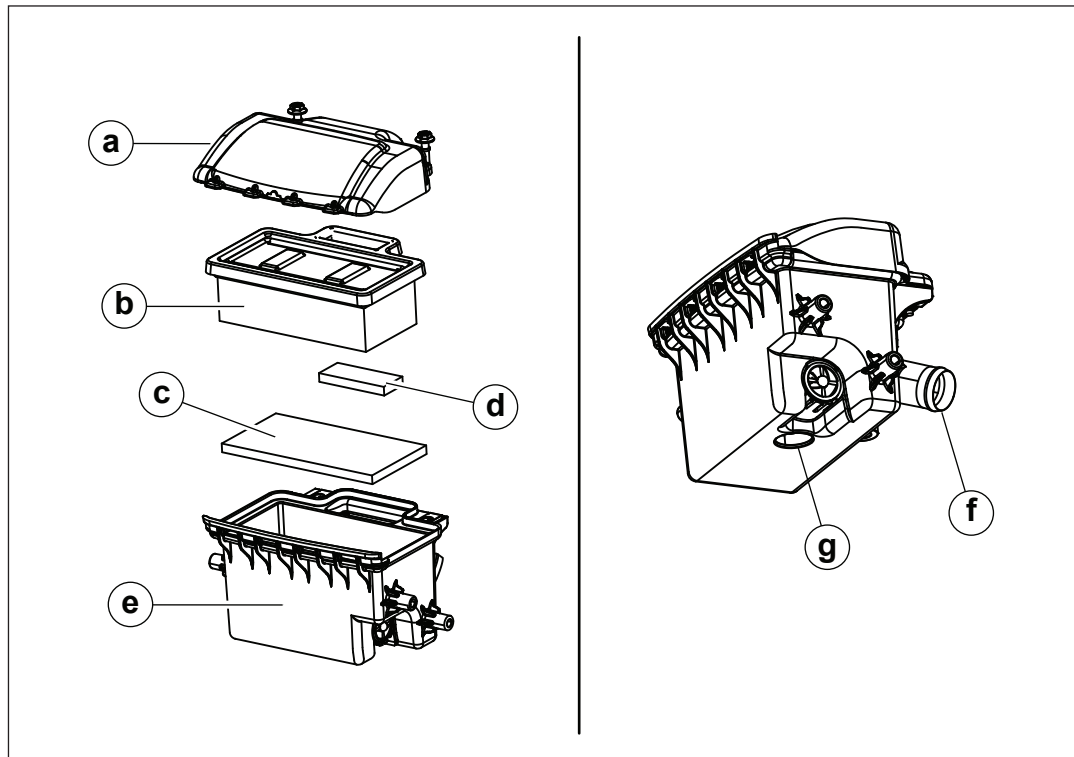

wc_gr011512

This procedure continues on the next page.

Continued from the previous page.

2. Remove the main paper filter element **(b)**, foam prefilter **(c)**, and foam discharge filter **(d)** and inspect them for holes or tears. Replace the element and filters if they are damaged.
3. Replace the main paper filter element **(b)** if it appears heavily soiled.
4. Clean the foam prefilter and foam discharge filter **(c, d)** with low-pressure compressed air. If the filters are extremely soiled, wash them in a solution of mild detergent and warm water. Rinse the filters thoroughly in clean water. Allow them to dry thoroughly before re-installing.

Note: Do not oil the foam prefilter or the foam discharge filter.

5. Wipe out the filter housing **(e)** with a clean cloth. Do not use compressed air.

NOTICE: Do not allow dirt to get into the engine intake port **(f)** while cleaning. Damage to engine will result.

6. Check that the precleaner debris ejector port **(g)** is clear.

Result The air cleaner has now been serviced.

5.4 Checking the Fuel Lines and Fittings

When Daily before starting the machine

Procedure 1. Check the fuel lines **(a)** and fittings **(b)** for cracks and leaks.

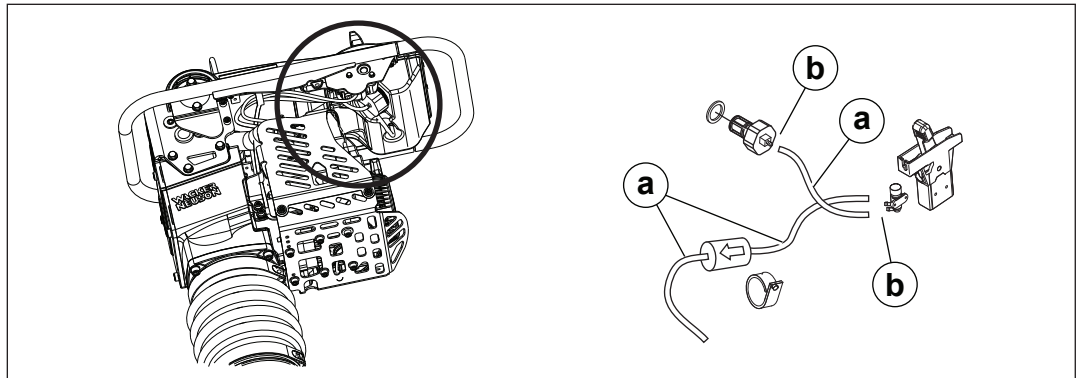

wc_gr010399

2. Repair or replace components as needed.

Result The fuel lines and fittings have now been checked.

5.5 Maintaining the Shoe Hardware

When On new machines, or after replacing shoe, check and tighten shoe hardware after the first five hours of operation. Inspect hardware every week thereafter.

Procedure Torque hardware as specified.

Cast Iron Shoe

Plastic Shoe

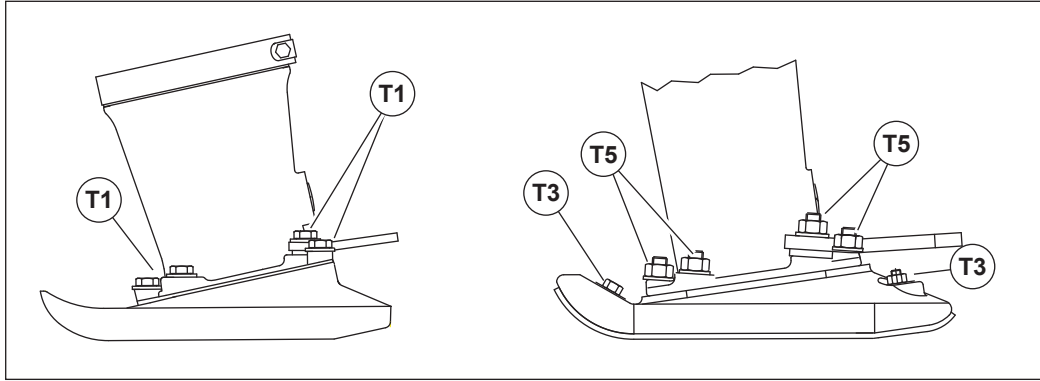

wc_gr005385

Torque	Nm	ft.lbs.
T1	86	63
T3	19	14
T5	79	58

5.6 Inspecting the Machine

When After the first five hours, and every week or every 25 hours thereafter (whichever comes first)

Requirements

- Engine stopped
- Machine cool to the touch
- Replacement parts as needed (refer to the Parts Book)

Procedure

1. Perform a walk-around inspection of the machine. Check for:
 - Loose or missing fasteners
 - Cracked, corroded, or missing parts
 - Damaged controls



CAUTION

Injury hazard.

► Do not operate the machine if any safety devices, guards, controls, or fasteners are loose, missing, or inoperative.

2. Tighten loose fasteners. Replace missing fasteners as needed.

3. Replace damaged or missing parts. Use only Wacker Neuson replacement parts or those parts equivalent to the original in all types of specifications, such as physical dimensions, type, strength, and material.

Result The machine has now been inspected.

5.7 Cleaning the Engine Cooling Fins

When Every week, or every 25 hours (whichever comes first)

Background Clean engine cooling fins allow fresh air to freely circulate around the combustion chamber. Free air circulation is necessary to prevent the engine from overheating.

- Requirements**
- Engine stopped and cool to the touch
 - Compressed air

Procedure Perform the procedure below to clean the engine cooling fins.

1. Locate the engine cooling fins (a).

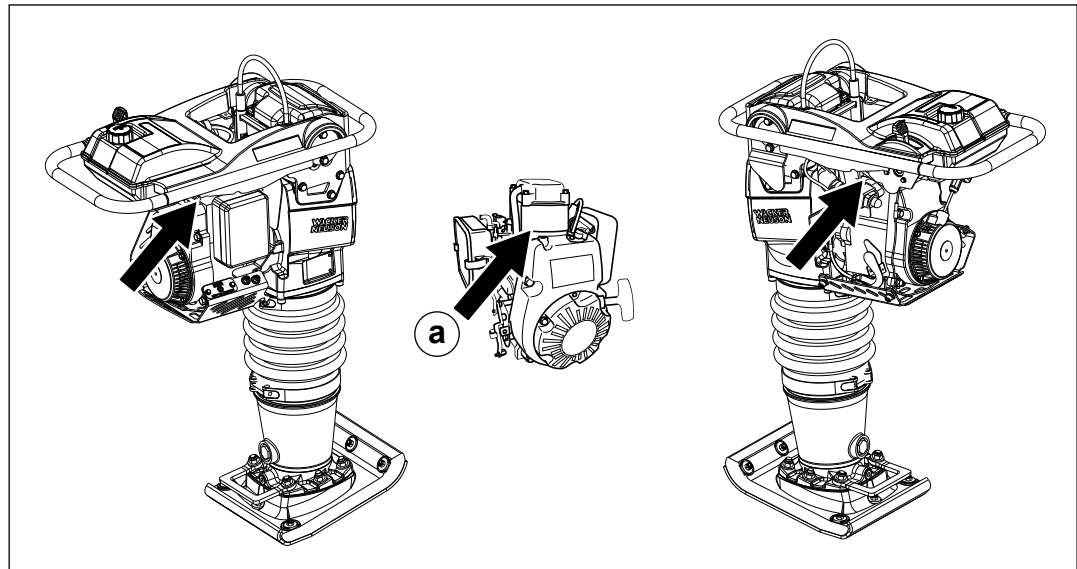

wc_gr011598

2. Use compressed air to blow dirt and debris off the engine cooling fins.

Result The engine cooling fins have been cleaned.

5.8 Cleaning and Checking the Spark Plug

When Every week, or every 25 hours (whichever comes first)

- Requirements**
- Engine stopped and cool to the touch
 - Spark plug wrench
 - Spark plug gap tool
 - Wire brush
 - Replacement spark plug as needed (see *Technical Data*)



WARNING

Burn hazard. The engine and muffler become very hot during operation and require cool-down time after the engine is stopped.

- ▶ Do not touch the engine, muffler, or spark plug until the machine is cool.

Procedure Perform the procedure below to clean and check the spark plug.

1. Disconnect the spark plug wire **(b)** and remove the spark plug **(a)**.

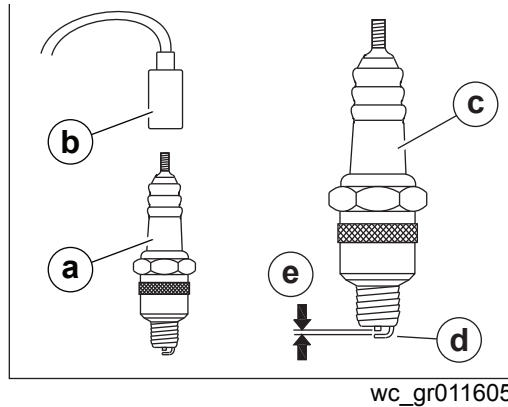

2. Inspect the spark plug. Replace the spark plug if the insulator **(c)** is cracked or chipped.
3. Clean spark plug electrodes **(d)** with a wire brush to remove carbon deposits.
4. Check the electrode gap **(e)** and adjust as needed. See *Technical Data* for the recommended gap setting.
5. Reinstall the spark plug and torque it to 35–41 Nm (25.8–30.2 ft.lbs.).

NOTICE: A loose spark plug can become very hot and may cause engine damage.

Result The spark plug has now been cleaned and checked.

5.9 Checking and Changing the Engine Oil

- When**
- ▶ Check the engine oil daily, before starting the machine.
 - ▶ Change the engine oil every month, or after every 100 hours of operation.

- Requirements**
- Engine is stopped, but still warm
 - Fresh engine oil (see *Technical Data* for quantity and type).
 - Plastic cloth and a container of sufficient volume to collect drained oil

Note: *Collect, store and dispose of drained oil in accordance with current environmental protection regulations.*



WARNING

Burn hazard. Engine and exhaust pipe become extremely hot during operation.

- ▶ Stop the engine and allow the machine to cool before changing the engine oil.



WARNING

Most used oil contains small amounts of materials that can cause cancer and other health problems if inhaled, ingested, or left in contact with skin for prolonged periods of time.

- ▶ Take steps to avoid inhaling or ingesting used engine oil.
- ▶ Wash skin thoroughly after exposure to used engine oil.

Checking Perform the procedure below to check/change the engine oil.

1. Set the rammer on a level surface as shown.

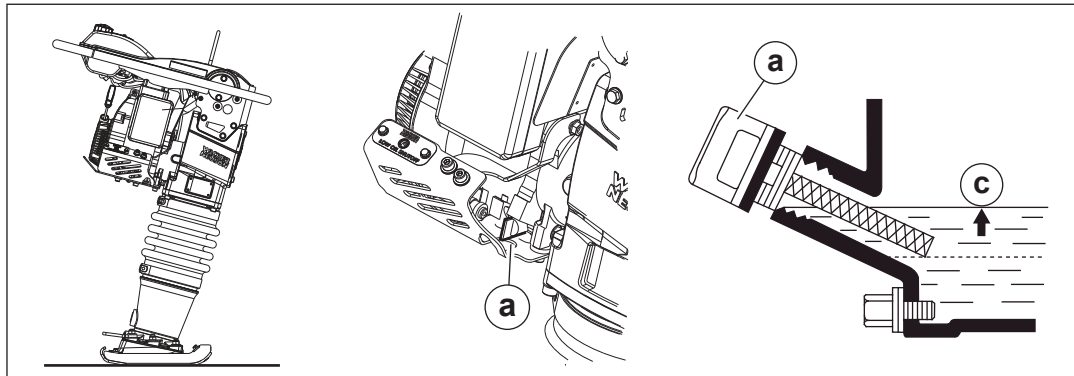

wc_gr011601

2. Remove the dipstick (a) and wipe it clean.
3. Re-insert the dipstick as shown to check the oil level. Do not thread it in.
4. Add oil as needed so that the engine oil level is up the opening (c).

This procedure continues on the next page.

Continued from the previous page.

Changing

1. Remove the dipstick **(a)**. Remove the drain plug **(b)** and drain the engine oil.

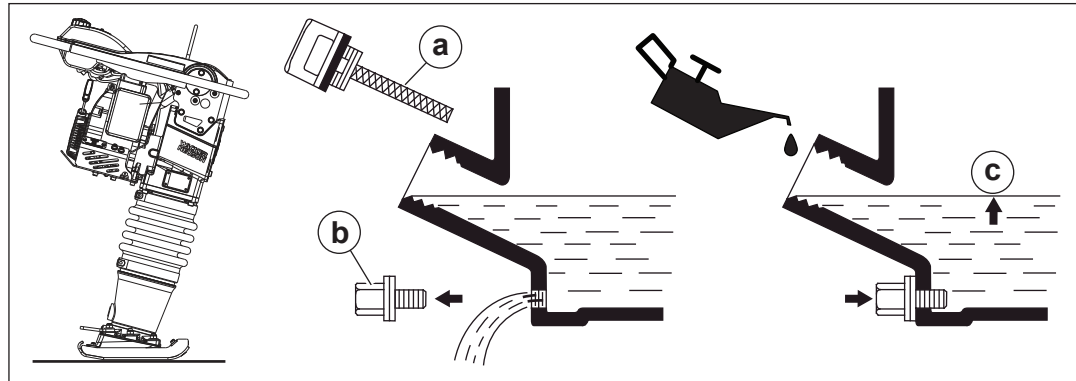

wc_gr011602

2. Re-install the drain plug **(b)**.
3. Fill the engine crankcase with the recommended oil up to the level of the opening **(c)**.
4. Re-install the dipstick **(a)**.

Result

The engine oil has now been changed.

5.10 Checking and Changing the Ramming System Oil

Background Lubricating oil is distributed throughout the ramming system by the vibrating action of the rammer. Holes drilled in the piston carry oil from the bottom of the rammer to the crankcase as the rammer operates. Oil in the ramming system must be maintained at the correct level to ensure that the ramming system operates efficiently.

Checking the oil level

Perform the following procedure to check the ramming system oil level.

Note: *If the rammer has been transported in the horizontal position or has recently been used, place it upright and allow it to stand in the upright position for 15 minutes before checking the oil level. This will allow the oil to settle and provide a more accurate reading.*

1. Tip the rammer so that it is perpendicular with the ground.

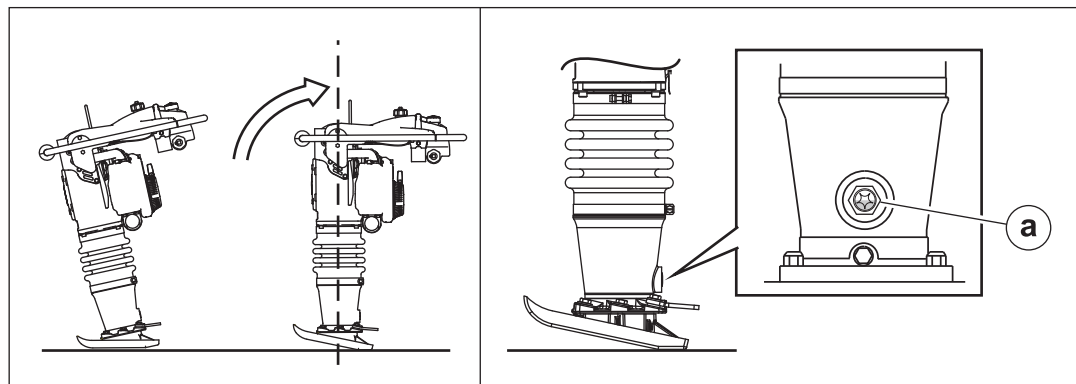

wc_gr007389

2. Check the oil through the sightglass (a).
The correct oil level will fill 1/2 to 3/4 of the sightglass. Add more oil if necessary.

Adding oil

Perform the following procedure to add oil to the ramming system.

NOTICE: Do not overfill the ramming system with oil. Excessively high levels of oil can create a hydraulic lock in the ramming system. This can result in erratic operation and cause damage to the engine clutch, the ramming system, and the shoe.

1. Tip the rammer forward to allow access to the sightglass. Secure the rammer in this position.

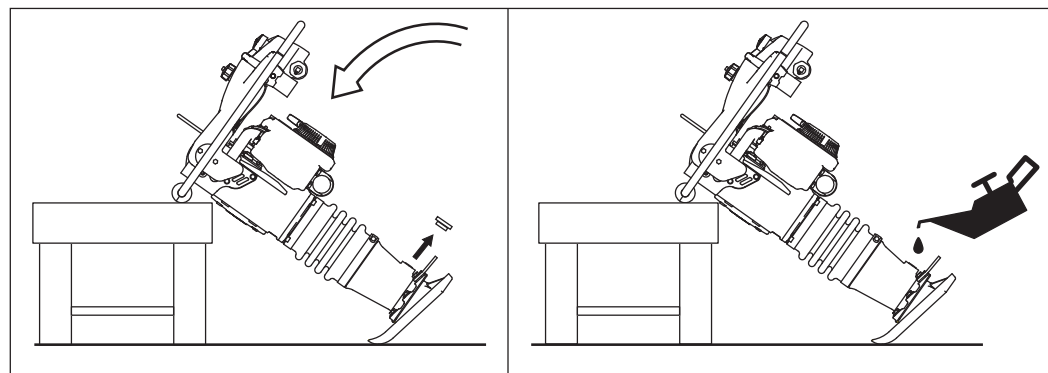

wc_gr007401

This procedure continues on the next page.

Continued from the previous page.

2. Remove the sightglass. Clean the threads of the sightglass, then wrap the threads with Teflon tape.
3. Add oil to the machine through the sightglass opening in the housing.
4. Re-install the sightglass, but do not torque it at this time.
5. Stand the machine upright and check the oil level.
6. Add oil as needed so that it fills 1/2 to 3/4 of the sightglass.
7. Torque the sightglass to 9 Nm (6 ft.lbs.).

Changing oil

Perform the following procedure to change the ramming system oil.

Note: *Dispose of used oil in accordance with local environmental regulations.*

1. Remove the drain plug **(b)**. (On BS 50 machines, remove the sightglass **(a)**.)

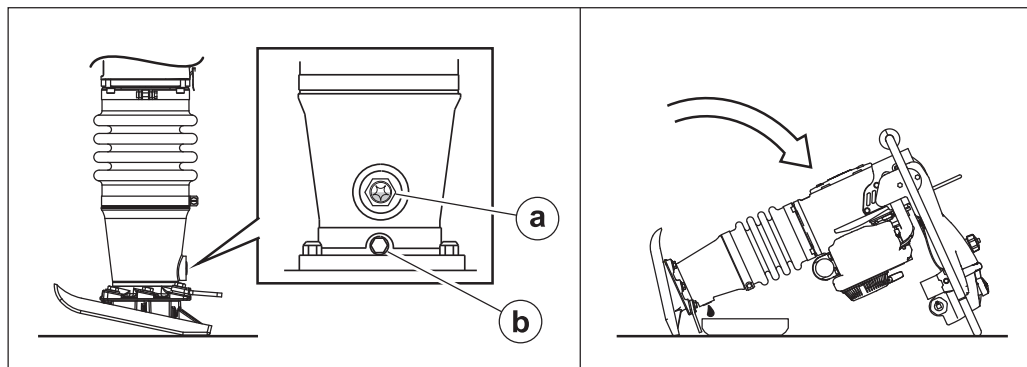

wc_gr007410

2. Tilt the rammer backward until it is resting on the handle and drain the oil into a suitable container.

Note: *It may take up to 10 minutes for the oil to drain.*

3. Re-install the drain plug. Torque it to 54 Nm (40 ft.lbs.).
4. Add oil as stated above.

Result

The ramming system oil has now been changed.

5.11 Inspecting and Cleaning the Fuel Filter

When Every year or every 1200 hours (whichever comes first)

- Requirements**
- Engine stopped
 - Fuel tank empty
 - Clean, dry, lint-free cloth
 - Replacement fuel filter (as needed)

Procedure Perform the procedure below to clean the fuel filter.

1. Clamp, then disconnect the fuel hose (b) from the fuel filter (a).

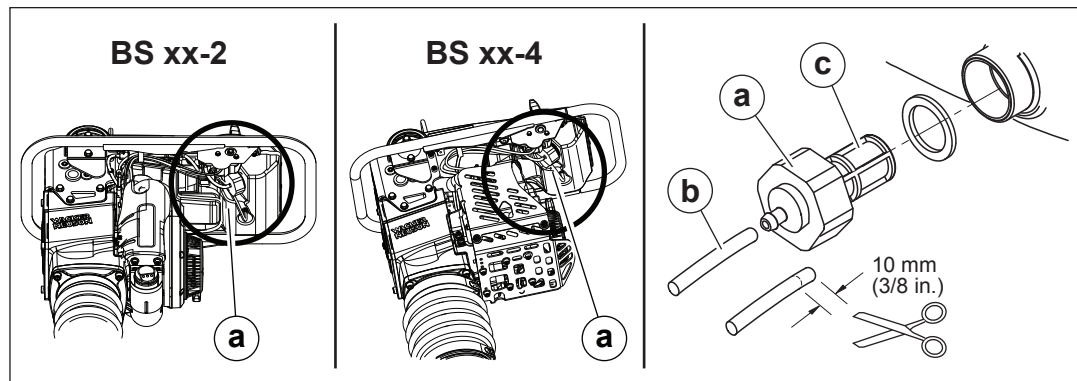

wc_gr010412

2. Unscrew and remove the fuel filter.
3. Wipe visible sediment or debris from the exterior of the fuel filter screen (c) using a clean, dry, lint-free cloth.
4. Inspect the fuel filter screen for cracks or damage. Replace the fuel filter if it is damaged.
5. Re-install the fuel filter.
6. To ensure a proper connection, cut approximately 10 mm (3/8 in.) from the end of the fuel hose, then connect it to the fuel filter.
7. Check for fuel leaks before restarting the machine.

Result The fuel filter has now been inspected and cleaned.

5.12 Replacing the In-Line Fuel Filter Assembly

When Every 5 months or every 500 hours (whichever comes first)

Requirements

- Engine stopped
- Replacement in-line fuel filter assembly

Procedure Perform the procedure below to replace the in-line fuel filter assembly. The in-line fuel filter assembly consists of the fuel filter **(a)** and two hoses **(b)**.

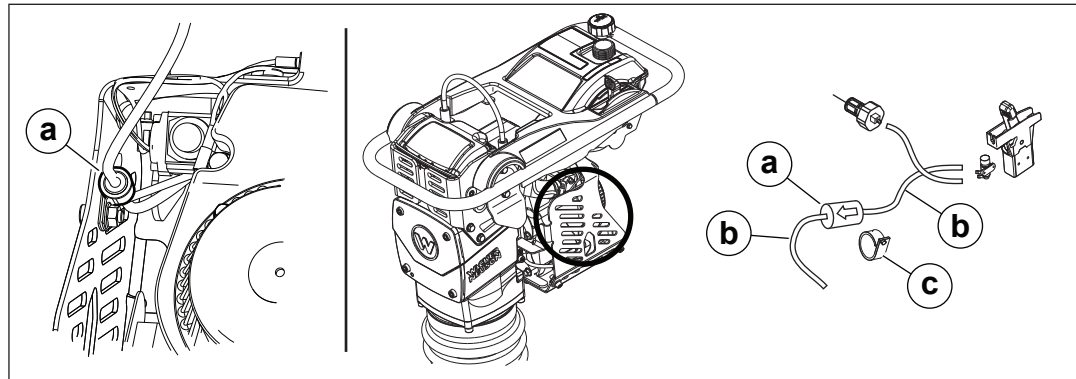

wc_gr011599

1. Set the throttle to the OFF position. This will close the fuel valve.
2. Remove the clamp **(c)** and remove the existing in-line fuel filter assembly. Discard the in-line fuel filter assembly in accordance with local environmental protection regulations.
3. Re-install the clamp **(c)** and connect the new in-line fuel filter assembly, making sure to orient the fuel filter as shown in the illustration.
4. Set the throttle to the IDLE position. This will open the fuel valve.
5. Check for fuel leaks before restarting the machine.

Result The in-line fuel filter assembly has now been replaced.

5.13 Long-Term Storage

Introduction	This machine requires preventive maintenance before long-term storage. Performing preventive maintenance helps to preserve machine components and ensures that the machine will be ready for future use.
When	Prepare your machine for extended storage if it will not be operated for 30 days or more.
Preparing for storage	<p>Follow the procedures below to prepare your machine for storage.</p> <ol style="list-style-type: none"> 1. Complete any needed repairs. 2. Replenish or change oils (engine, ramming system, etc.) per the intervals specified in the Periodic Maintenance table. 3. 4-cycle machines only: Consult the engine owner's manual for instructions on preparing the engine for storage.
Stabilizing the fuel	<p>After completing the procedures listed above, fill the fuel tank completely and add a high-quality stabilizer to the fuel.</p> <ul style="list-style-type: none"> ■ Choose a stabilizer that includes cleaning agents and additives designed to coat/protect the cylinder walls. ■ Make sure the stabilizer you use is compatible with the fuel in your area, fuel type, grade, and temperature range. Do not add extra alcohol to fuels which already contain it (for example, E10). ■ Add the correct amount of stabilizer per the manufacturer's recommendations.
Storing the machine	<p>Perform these remaining steps to store your machine.</p> <ol style="list-style-type: none"> 1. Wash the machine and allow it to dry. 2. Move the machine to a clean, dry, secure storage location. 3. Secure the machine in an upright position. 4. Cover the machine.

5.14 Machine Disposal / Decommissioning

Introduction This machine must be properly decommissioned at the end of its service life. Responsible disposal of recyclable components, such as plastic and metal, ensures that these materials can be reused—conserving landfill space and valuable natural resources.

Responsible disposal also prevents toxic chemicals and materials from harming the environment. The operating fluids in this machine, including fuel, engine oil, ramming system oil, and grease, may be considered hazardous waste in many areas. Before decommissioning this machine, read and follow local safety and environmental regulations pertaining to the disposal of construction equipment.

Preparation Perform the following tasks to prepare the machine for disposal.

- Move the machine to a protected location where it will not pose any safety hazards and cannot be accessed by unauthorized individuals.
- Ensure that the machine cannot be operated from the time of final shutdown to disposal.
- Drain all fluids, including fuel, engine oil, and ramming system oil.
- Seal any fluid leaks.

Disposal Perform the following tasks to dispose of the machine.

- Disassemble the machine and separate all parts by material type.
- Dispose of recyclable parts as specified by local regulations.
- Dispose of all non-hazardous components that cannot be recycled.
- Dispose of waste fuel, oil, and grease in accordance with local environmental protection regulations.

6 Troubleshooting

Problem	Cause	Remedy
Engine does not start, or stalls.	No fuel in tank	Add fuel.
	Spark plug fouled	Clean or replace spark plug.
	Engine oil level low	Add engine oil.
Engine does not accelerate, is hard to start, or runs erratically.	Spark plug fouled	Clean or replace spark plug.
	Obstructed muffler and/or exhaust port	Clear obstructions.
	Leaky crankshaft seals	Replace crankshaft seals.
	Dirty or clogged air cleaner	Service air cleaner.
	Engine oil level low	Add engine oil.
Engine overheats.	Dirty cooling fins and/or fan blades	Clean cooling fins and/or fan blades.
Engine runs, rammer does not tamp.	Damaged clutch	Repair or replace clutch.
	Broken connecting rod or crank gear	Replace broken parts.
	Low engine performance: compression loss	Adjust compression.
	Obstructed exhaust port	Clear obstructions.
Engine runs, rammer operation is erratic.	Oil or grease on clutch	Remove oil/grease from clutch.
	Broken or worn springs	Replace broken parts.
	Soil buildup on ramming shoe	Clean soil from ramming shoe.
	Broken parts in ramming system or crankcase	Replace broken parts.
	Engine operating speed too high	Adjust engine operating speed.
Low oil shutoff indicator flashes slowly, illuminates and remains lit. Engine does not start.	Engine oil low	See topic "Low Oil Shut-Off Switch."

7 Technical Data

7.1 BS 50-4s

Machine		BS 50-4s	
Item number		5200000644 5200000662	5200000679 5200000680
Engine model		WM 100	
Operating weight	kg (lb)	63 (139)	
Engine speed—operating	rpm	3,950 ± 100	4,200 ± 100
Engine speed—idle	rpm	2,000 ± 100	
Clutch Engagement	rpm	2,650 ± 100	
Max. rated power @ rated speed ¹	kW (hp)	2.4 (3.2)	
Spark plug	type	NGK: BMR4A or CHAMPION: RCJ14	
Electrode gap	mm (in.)	0.6–0.7 (0.023–0.027)	
Air cleaner	type	Four-stage with cyclonic precleaner	
Engine lubrication	oil grade	SAE 10W30 SJ or higher	
Engine oil capacity	L (qt)	0.30 (0.3)	
Fuel tank capacity	L (qt)	3.0 (3.2)	
Fuel	type	Regular unleaded gasoline	
Fuel consumption	L (qt)/hr	1.2 (1.3)	
Running time	hr	2.5	
Ramming system lubrication	oil grade	SAE 10W30 SJ or higher	
Ramming system capacity	ml (oz.)	890 (30)	

¹Gross engine power rating per SAE J1995. Actual power output may vary due to conditions of specific use.

7.2 BS 50-4As

Machine		BS 50-4As		
Item number		5200018219 5200018226		5100015099
Engine model		Honda GX100		Honda GXR120
Operating weight	kg (lb)	64 (141)		
Engine speed—operating	rpm	3,950 ± 100	4,200 ± 100	3,950 ± 100
Engine speed—idle	rpm	1,850 ± 150		
Clutch Engagement	rpm	2,650 ± 100		
Max. rated power @ rated speed ¹	kW (hp)	2.35 (3.15)		2.80 (3.75)
Spark plug	type	NGK: CR5HSB or DENSO U16FSR-UB		
Electrode gap	mm (in.)	0.6–0.7 (0.024–0.028)		
Air cleaner	type	Four-stage with cyclonic precleaner		
Engine lubrication	oil grade	SAE 10W30 SJ or higher		
Engine oil capacity	L (qt)	0.40 (0.42)		
Fuel tank capacity	L (qt)	3.0 (3.2)		
Fuel	type	Regular unleaded gasoline		
Fuel consumption	L (qt)/hr	0.88 (0.93)		1.00 (1.10)
Running time	hr	3.4		3.0
Ramming system lubrication	oil grade	SAE 10W30 SJ or higher		
Ramming system capacity	ml (oz.)	890 (30)		

¹Gross engine power rating per SAE J1995. Actual power output may vary due to conditions of specific use.

7.3 BS 60-4s

Machine		BS 60-4s	
Item number		5200000647 5200000667 5200000674 5200000675	5200000648 5200000668 5200022984
Engine model		WM 100	
Operating weight	kg (lb)	71 (156)	
Engine speed—operating	rpm	3,950 ± 100	4,200 ± 100
Engine speed—idle	rpm	2,000 ± 100	
Clutch Engagement	rpm	2,650 ± 100	
Max. rated power @ rated speed ¹	kW (hp)	2.4 (3.2)	
Spark plug	type	NGK: BMR4A or CHAMPION: RCJ14	
Electrode gap	mm (in.)	0.6–0.7 (0.023–0.027)	
Air cleaner	type	Four-stage with cyclonic precleaner	
Engine lubrication	oil grade	SAE 10W30 SJ or higher	
Engine oil capacity	L (qt)	0.30 (0.3)	
Fuel tank capacity	L (qt)	3.0 (3.2)	
Fuel	type	Regular unleaded gasoline	
Fuel consumption	L (qt)/hr	1.2 (1.3)	
Running time	hr	2.5	
Ramming system lubrication	oil grade	SAE 10W30 SJ or higher	
Ramming system capacity	ml (oz.)	890 (30)	

¹Gross engine power rating per SAE J1995. Actual power output may vary due to conditions of specific use.

7.4 BS 60-4As

Machine		BS 60-4As		
Item number		5200014910 5200018231 5200018232 5200018233		5100015123
Engine model		Honda GX100		Honda GXR120
Operating weight	kg (lb)	72 (158)		
Engine speed—operating	rpm	3,950 ± 100	4,200 ± 100	3,950 ± 100
Engine speed—idle	rpm	1,850 ± 150		
Clutch Engagement	rpm	2,650 ± 100		
Max. rated power @ rated speed ¹	kW (hp)	2.35 (3.15)		2.80 (3.75)
Spark plug	type	NGK: CR5HSB or DENSO: U16FSR-UB		
Electrode gap	mm (in.)	0.6–0.7 (0.024–0.028)		
Air cleaner	type	Four-stage with cyclonic precleaner		
Engine lubrication	oil grade	SAE 10W30 SJ or higher		
Engine oil capacity	L (qt)	0.40 (0.42)		
Fuel tank capacity	L (qt)	3.0 (3.2)		
Fuel	type	Regular unleaded gasoline		
Fuel consumption	L (qt)/hr	0.88 (0.93)		1.00 (1.10)
Running time	hr	3.0		3.4
Ramming system lubrication	oil grade	SAE 10W30 SJ or higher		
Ramming system capacity	ml (oz.)	890 (30)		

¹Gross engine power rating per SAE J1995. Actual power output may vary due to conditions of specific use.

7.5 BS 70-4As

Machine		BS 70-4As
Item number		5100015124, 5100015126
Engine model		Honda GXR120
Operating weight	kg (lb)	80 (177)
Engine speed—operating	rpm	3,950 ± 100
Engine speed—idle	rpm	1,850 ± 150
Clutch Engagement	rpm	2,650 ± 100
Max. rated power @ rated speed ¹	kW (hp)	2.80 (3.75)
Spark plug	type	NGK: CR5HSB or DENSO: U16FSR-UB
Electrode gap	mm (in.)	0.6–0.7 (0.024–0.028)
Air cleaner	type	Four-stage with cyclonic precleaner
Engine lubrication	oil grade	SAE 10W30 SJ or higher
Engine oil capacity	L (qt)	0.40 (0.42)
Fuel tank capacity	L (qt)	3.0 (3.2)
Fuel	type	Regular unleaded gasoline
Fuel consumption	L (qt)/hr	1.00 (1.10)
Running time	hr	3.4
Ramming system lubrication	oil grade	SAE 10W30 SJ or higher
Ramming system capacity	ml (oz.)	890 (30)

¹Gross engine power rating per SAE J1995. Actual power output may vary due to conditions of specific use.

7.6 Sound Measurements

Products are tested for sound pressure level in accordance with EN 500-4:2011.
 Sound power level is tested in accordance with European Directive 2000/14/EC -
 Noise Emission in the Environment by Equipment for use outdoors.

Machine		Sound Pressure at Operator's Location dB(A)	Guaranteed Sound Power dB(A)
BS 50-4As	5200018219	90	108
	5200018226		
BS 50-4s BS 50-4As	5200000644	91	108
	5200000662		
	5100015099		
BS 60-4s	5200000648	91	108
	5200000668		
BS 60-4As	5200014910	92	108
	5200018231		
	5200018232		
	5200018233		
	5100015123		
BS 60-4s BS 60-4As	5200000647	98	108
	5200000667		
	5200000674		
	5200000675		
	5200011110		
	5200011111		
BS 70-4As	5100015124	92	108
	5100015126		

7.7 Vibration Measurements

Products are tested for hand/arm vibration (HAV) level in accordance with ISO 5349, EN1033, and EN500-4 where applicable.

Machine		HAV m/sec ²	HAV ft/sec ²
BS 50-4s	5200000644 5200000662	9.2	30.2
BS 50-4s	5200000679	4.9	16.1
BS 50-4s	5200000680	8.6	28.2
BS 50-4As	5200018219 5200018226	9.0	29.5
BS 50-4As	5100015099	9.4	30.8
BS 60-4s BS 60-4As	5200000647 5200000648 5200000667 5200000668 5200000674 5200000675 5200011110 5200011111	6.5	21.3
BS 60-4As	5200014910 5200018231 5200018232 5200018233	9.1	29.8
BS 60-4As	5100015123	9.2	30.2
BS 70-4As	5100015124 5100015126	7.4	24.3

HAV Uncertainties Hand-transmitted vibration was measured per ISO 5349-1. This measurement includes an uncertainty of 1.5 m/s².

7.8 Dimensions

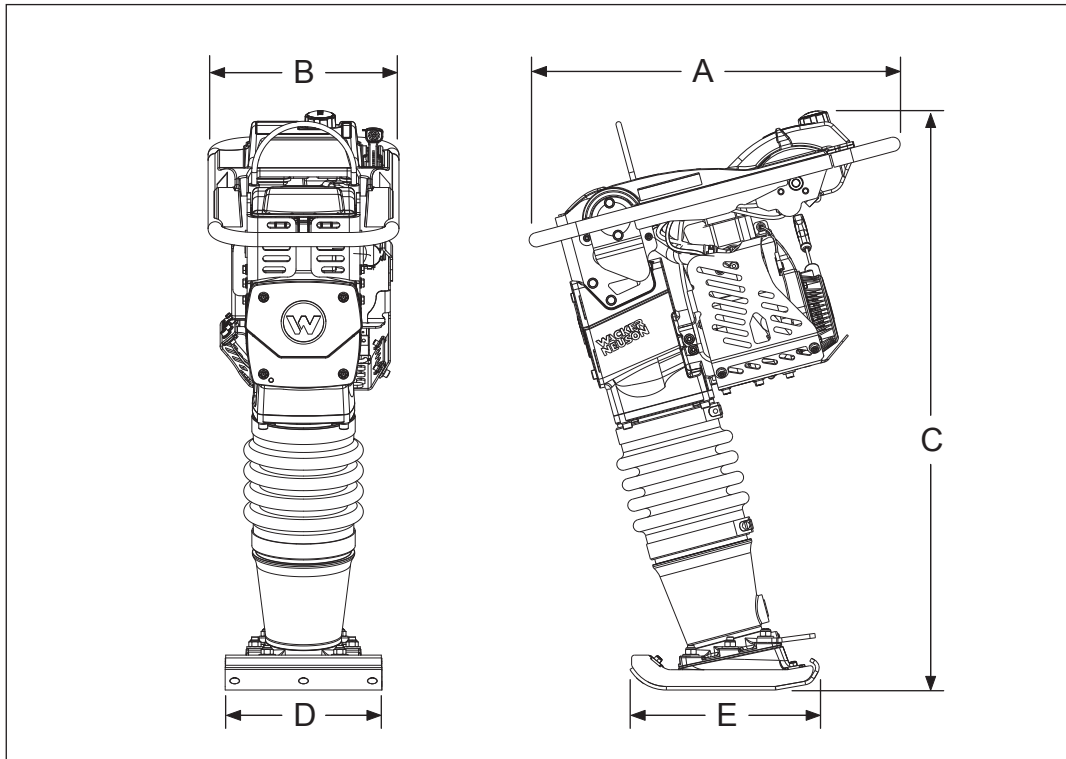

wc_gr011607

	A mm (in.)	B mm (in.)	C mm (in.)	D mm (in.)	E mm (in.)
BS 50-4s BS 50-4As	673 (26.5)	343 (13.5)	940 (37)	280 (11.0)	337 (13.27)
BS 60-4s BS 60-4As	673 (26.5)	343 (13.5)	965 (38)	280 (11.02)	336 (13.25)
BS 70-4As	673 (26.5)	343 (13.5)	965 (38)	280 (11.02)	336 (13.25)

Notes



8 Emission Control Systems Information and Warranty—Gasoline

The Emission Control Warranty and associated information is valid only for the U.S.A., its territories, and Canada.

8.1 Emission Control System Background Information

Introduction

Wacker Neuson spark-ignited engines/equipment must conform with applicable Environmental Protection Agency (EPA) and the State of California emissions regulations. There are two types of emissions that fall under these regulations: 1) exhaust, and 2) evaporative. These regulations require that manufacturers warrant the emission control systems for defects in materials and workmanship.

Furthermore, EPA and California regulations require all manufacturers to furnish written instructions describing how to operate and maintain the engines/equipment including the emission control systems. This information is provided with all Wacker Neuson engines/equipment at the time of purchase.

Exhaust Emissions

The combustion process produces carbon monoxide, oxides of nitrogen, and hydrocarbons. Control of hydrocarbons and oxides of nitrogen is very important because, under certain conditions, they react to form photochemical smog when subjected to sunlight. Carbon monoxide does not react in the same way, but it is toxic.

Wacker Neuson utilizes lean carburetor settings and other systems to reduce the emissions of carbon monoxide, oxides of nitrogen, and hydrocarbons.

Evaporative Emissions

Evaporative emissions are fuel emissions and generally include emissions that result from permeation of fuel through the fuel-system materials or from ventilation of the fuel system.

Wacker Neuson utilizes low-permeation fuel lines and fuel tanks where applicable to reduce evaporative emissions.

Problems that may affect Emissions

If any of the following symptoms arise, have the engine/equipment inspected and repaired by a Wacker Neuson dealer/service center.

- Hard starting or stalling after starting
 - Rough idling
 - Misfiring or backfiring under load
 - Afterburning (backfiring)
 - Presence of black exhaust smoke during operation
 - High fuel consumption
-

Emission Control Systems Information and Warranty—Gasoline

Tampering and Altering

Tampering with or altering the emission control system may increase emissions beyond the legal limit. If evidence of tampering is found, Wacker Neuson may deny a warranty claim. Among those acts that constitute tampering are:

- Removing or altering of any part of the air intake, fuel, or exhaust systems.
- Altering or defeating the speed-adjusting mechanism causing the engine to operate outside its design parameters.

8.2 Limited Defect Warranty for Exhaust Emission Control System

See the supplied engine owner's manual for the applicable emission warranty statement.

8.3 Limited Defect Warranty for Wacker Neuson Evaporative Emission Control Systems

The Emission Control Warranty is valid only for the U.S.A., its territories, and Canada.

Wacker Neuson Sales Americas, LLC, N92 W15000 Anthony Avenue, Menomonee Falls, WI 53051, (hereinafter "Wacker Neuson") warrants to the initial retail purchaser and each subsequent owner, that this engine/equipment, including all parts of its evaporative emission control system, have been designed, built, and equipped to conform at the time of initial sale to all applicable evaporative emission regulations of the U.S. Environmental Protection Agency (EPA), and that the engine/equipment is free of defects in materials and workmanship which would cause this engine/equipment to fail to conform to EPA regulations during its warranty period.

Wacker Neuson is also liable for damages to other engine/equipment components caused by a failure of any warranted parts during the warranty period.

Limited Defect Warranty Period for Wacker Neuson Evaporative Emission Control Systems

The warranty period for this engine/equipment begins on the date of sale to the initial purchaser and continues for a minimum of two (2) years. For the warranty terms for your specific engine/equipment, visit wackerneuson.com.

Any implied warranties are limited to the duration of this written warranty.

What is covered

Wacker Neuson recommends the use of genuine Wacker Neuson parts, or the equivalent, whenever maintenance is performed. The use of replacement parts not equivalent to the original parts may impair the effectiveness of the engine/equipment emission controls systems. If such a replacement part is used in the repair or maintenance of the engine/equipment, assure yourself that such part is warranted by its manufacturer to be equivalent to the parts offered by Wacker Neuson in performance and durability. Furthermore, if such a replacement part is used in the repair or maintenance of the engine/equipment, and an authorized

Emission Control Systems Information and Warranty—Gasoline

Wacker Neuson dealer/service center determines it is defective or causes a failure of a warranted part, the claim for repair of the engine/equipment may be denied. If the part in question is not related to the reason the engine/equipment requires repair, the claim will not be denied.

For the components listed in the following table, an authorized Wacker Neuson dealer/service center will, at no cost to you, make the necessary diagnosis, repair, or replacement necessary to ensure that the engine/equipment complies with the applicable EPA regulations. All defective parts replaced under this warranty become property of Wacker Neuson.

System Covered	Components
Evaporative emissions	Fuel tank (if applicable)
	Fuel tank cap (if applicable)
	Fuel line (if applicable)
	Fuel line fittings (if applicable)
	Clamps (if applicable)
	Carbon canister (if applicable)
	Purge port connector (if applicable)
Miscellaneous parts associated with the evaporative emission control system	Clamps
	Gaskets
	Mounting brackets

What is not covered

- Failures other than those resulting from defects in material or workmanship.
- Any systems or parts which are affected or damaged by owner abuse, tampering, neglect, improper maintenance, misuse, improper fueling, improper storage, accident and/or collision; the incorporation of, or any use of, add-on or modified parts, or unsuitable attachments, or the alteration of any part.
- Replacement of expendable maintenance items made in connection with required maintenance services after the item's first scheduled replacement as listed in the maintenance section of the engine/equipment operator's manual, such as spark plugs and filters.
- Incidental or consequential damages such as loss of time or the use of the engine/equipment, or any commercial loss due to the failure of the engine/equipment.
- Diagnosis and inspection charges that do not result in warranty-eligible service being performed.
- Any non-authorized replacement part, or malfunction of authorized parts due to use of non-authorized parts.

Owner's Warranty Responsibility

The engine/equipment owner, is responsible for the performance of the required maintenance listed in the Wacker Neuson engine/equipment operator's manual. Wacker Neuson recommends that all receipts covering maintenance on the

Emission Control Systems Information and Warranty—Gasoline

engine/equipment be retained, but Wacker Neuson cannot deny warranty coverage solely for the lack of receipts or for the failure to ensure the performance of all scheduled maintenance.

Normal maintenance, replacement, or repair of emission control devices and systems may be performed by any repair establishment or individual; however, warranty repairs must be performed by an authorized Wacker Neuson dealer/service center.

The engine/equipment must be presented to an authorized Wacker Neuson dealer/service center as soon as a problem exists. Contact Wacker Neuson Product Support Department (1-800-770-0957) or visit wackerneuson.com to find a dealer/service center in your area, or to answer questions regarding warranty rights and responsibilities.

How to Make a Claim

In the event that any emission-related part is found to be defective during the warranty period, you shall notify Wacker Neuson Product Support Department (1-800-770-0957, or technical.support@wackerneuson.com, or wackerneuson.com), and you will be advised of the appropriate dealer/service center where warranty repair can be performed. All repairs qualifying under this limited warranty must be performed by an authorized Wacker Neuson dealer/service center.

You must take your Wacker Neuson engine/equipment along with proof of original purchase date, at your expense, to the authorized Wacker Neuson dealer/service center during their normal business hours.

For owners located more than 100 miles from an authorized dealer/service center (excluding the states with high-altitude areas as identified in 40 CFR Part 1068, Appendix III), Wacker Neuson will pay for pre-approved shipping costs to and from an authorized Wacker Neuson dealer/service center.

Claims for repair or adjustment found to be caused solely by defects in material or workmanship will not be denied because the engine/equipment was not properly maintained and used.

The warranty repairs should be completed in a reasonable amount of time, not to exceed 30 days.

Important: For spare parts information, please see your Wacker Neuson Dealer, or visit the Wacker Neuson website at <http://www.wackerneuson.com/>.

Wichtig! Informationen über Ersatzteile erhalten Sie von Ihrem Wacker Neuson Händler oder besuchen Sie die Wacker Neuson Website unter <http://www.wackerneuson.com/>.

Important : Pour des informations sur les pièces détachées, merci de consulter votre distributeur Wacker Neuson, ou de visiter le site Internet de Wacker Neuson sur <http://www.wackerneuson.com/>.

Importante : Para saber más sobre las piezas de repuesto, póngase en contacto con su distribuidor de Wacker Neuson o acceda al sitio web de Wacker Neuson en <http://www.wackerneuson.com/>.

Importante : Per informazioni sui pezzi di ricambio, contattare il rivenditore Wacker Neuson o visitare il sito di Wacker Neuson all'indirizzo www.wackerneuson.com.

Viktigt : För information om reservdelar, kontakta din Wacker Neuson-leverantör eller besök Wacker Neusons webbplats på <http://www.wackerneuson.com/>.

Tärkeää : Pyydä varaosatietoja Wacker Neusonin jälleenmyyjältä tai vieraile Wacker Neusonin web-sivustolla osoitteessa <http://www.wackerneuson.com/>

Viktig : For informasjon om reservedeler, vennligst kontakt din Wacker Neuson-forhandler, eller besøk Wacker Neusons nettside på <http://www.wackerneuson.com/>.

Viktigt : Hvis du ønsker oplysninger om reservedele, bedes du kontakte din Wacker Neuson forhandler eller besøg Wacker Neuson websiden på <http://www.wackerneuson.com/>.

Belangrijk! Neem contact op met uw Wacker Neuson dealer of bezoek de website van Wacker Neuson op <http://www.wackerneuson.com/> voor meer informatie over reserveonderdelen.

Importante : Para obter informações sobre as peças sobresselentes, consulte o seu fornecedor da Wacker Neuson ou acesse ao site Web da Wacker Neuson em http://www.wackerneuson.com

Ważne : W celu uzyskania informacji na temat części zamiennych skontaktuj się z przedstawicielem firmy Wacker Neuson lub skorzystaj z witryny internetowej <http://www.wackerneuson.com/>.

Důležitě upozornění! Pro informace o náhradních dílech, prosím, kontaktujte svého Wacker Neuson dealera, nebo navštivte webové stránky <http://www.wackerneuson.com/>.

FONTOS: A pótalkatrészekre vonatkozó információkért kérjük, forduljon Wacker Neuson kereskedőjéhez vagy látogasson el a Wacker Neuson weboldalára a következő címen: <http://www.wackerneuson.com/>.

Важно! Для ознакомления с информацией о запасных частях, пожалуйста, обратитесь к местному торговому представителю компании Wacker Neuson или посетите веб-сайт <http://www.wackerneuson.com/>.

Σημαντικό : Για πληροφορίες σχετικά με τα ανταλλακτικά, μιλήστε με τον αντιπρόσωπό σας της Wacker Neuson, ή επισκεφθείτε τον ιστότοπο <http://www.wackerneuson.com/>.

Važno : Za rezervne dijelove obratite se svom Wacker Neuson prodavaču ili posjetite mrežne stranice tvrtke Wacker Neuson: <http://www.wackerneuson.com/>.

Önemli : Yedek parça bilgileri için Wacker Neuson Bayinize bakın veya Wacker Neuson web sitesini ziyaret edin. <http://www.wackerneuson.com/>

重要 交換部品の情報については、ワッカーノイソンディーラーにお問い合わせ頂くか、ワッカーノイソンウェブサイト <http://www.wackerneuson.com/> をご覧ください。

重要 有关备件信息，请咨询您的威克诺森经销商或访问威克诺森网站：
<http://www.wackerneuson.com/>。

Important : Pentru informații referitoare la piesele de schimb, vă rugăm să vă adresați distribuitorului Wacker Neuson sau să vizitați site-ul web Wacker Neuson la adresa <http://www.wackerneuson.com/>.

Важно : За информация относно резервни части, моля, обърнете се към местния дилър на Wacker Neuson или посетете уебсайта на Wacker Neuson на адрес <http://www.wackerneuson.com/>.

Wacker Neuson Produktion GmbH & Co. KG, Preußenstraße 41, D-80809 München,

Tel.: +49-(0)89-3 54 02-0 Fax: +49 - (0)89-3 54 02-390

Wacker Neuson Production Americas LLC, N92W15000 Anthony Ave., Menomonee Falls, WI. 53051

Tel.: (262) 255-0500 Fax: (262) 255-0550 Tel.: (800) 770-0957

Wacker Neuson Limited - Room 1701-03 & 1717-20, 17/F, Tower 1, Grand Century Place, 193 Prince Edward Road West, Mongkok, Kowloon, Hongkong. Tel: (852) 3605 5360, Fax: (852) 2758 0032

Free Manuals Download Website

<http://myh66.com>

<http://usermanuals.us>

<http://www.somanuals.com>

<http://www.4manuals.cc>

<http://www.manual-lib.com>

<http://www.404manual.com>

<http://www.luxmanual.com>

<http://aubethermostatmanual.com>

Golf course search by state

<http://golfingnear.com>

Email search by domain

<http://emailbydomain.com>

Auto manuals search

<http://auto.somanuals.com>

TV manuals search

<http://tv.somanuals.com>