

Operator's Manual

Pump

PT2 / PT2A / PT2H PT3 / PT3A / PT3H

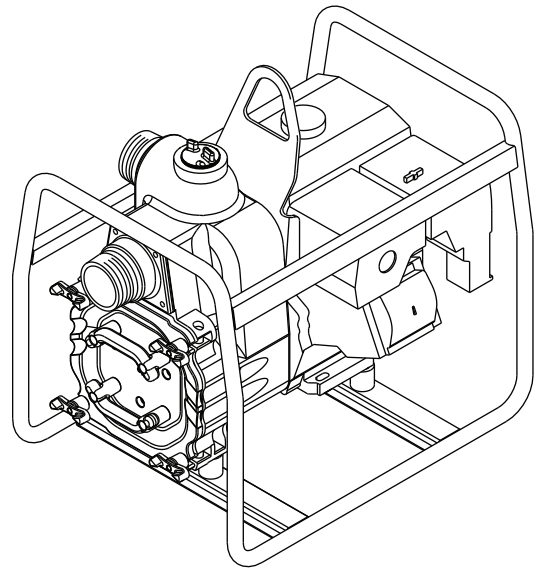

EN

5100016561	02	0915
------------	----	------



Copyright notice

© Copyright 2015 by Wacker Neuson Production Americas LLC

All rights, including copying and distribution rights, are reserved.

This publication may be photocopied by the original purchaser of the machine. Any other type of reproduction is prohibited without express written permission from Wacker Neuson Production Americas LLC.

Any type of reproduction or distribution not authorized by Wacker Neuson Production Americas LLC represents an infringement of valid copyrights. Violators will be prosecuted.

Trademarks

All trademarks referenced in this manual are the property of their respective owners.

Manufacturer

Wacker Neuson Production Americas LLC

N92W15000 Anthony Avenue

Menomonee Falls, WI 53051 U.S.A.

Tel: (262) 255-0500 · Fax: (262) 255-0550 · Tel: (800) 770-0957

www.wackerneuson.com

Original instructions

This Operator's Manual presents the original instructions. The original language of this Operator's Manual is American English.

Foreword

SAVE THESE INSTRUCTIONS—This manual contains important instructions for the machine models below. These instructions have been written expressly by Wacker Neuson Production Americas LLC and must be followed during installation, operation, and maintenance of the machines.

Machine	Item Number
PT2	5000009318
PT2A, PT2A(I)	5000009092, 5000009095, 5000009237
PT2(I)	5000620725
PT2H, PT2H(I)	5000009094, 5000009097
PT3	5000009321, 5000009322
PT3A, PT3A(I)	5000009098, 5000009101, 5000009240, 5000620800
PT3(I)	5000620726
PT3H, PT3H(I)	5000009100, 5000009103

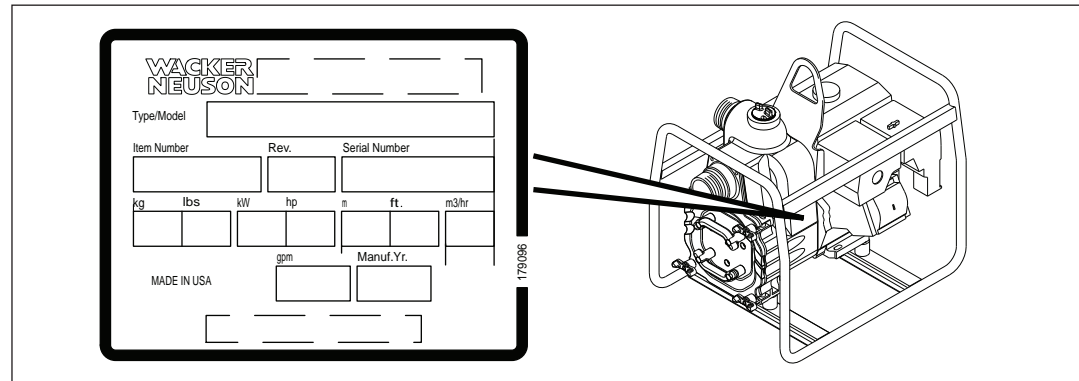

wc_gr012659

Machine identification

A nameplate listing the model number, item number, revision number, and serial number is attached to this machine. The location of the nameplate is shown above.

Serial number (S/N)

For future reference, record the serial number in the space provided below. You will need the serial number when requesting parts or service for this machine.

Serial Number:

Machine documentation

- From this point forward in this documentation, Wacker Neuson Production Americas LLC will be referred to as Wacker Neuson.
- Keep a copy of the Operator’s Manual with the machine at all times.
- For spare parts information, please see your Wacker Neuson Dealer, or visit the Wacker Neuson website at <http://www.wackerneuson.com/>.
- When ordering parts or requesting service information, be prepared to provide the machine model number, item number, revision number, and serial number.

Expectations for information in this manual

- This manual provides information and procedures to safely operate and maintain the above Wacker Neuson model(s). For your own safety and to reduce the risk of injury, carefully read, understand, and observe all instructions described in this manual.
 - Wacker Neuson expressly reserves the right to make technical modifications, even without notice, which improve the performance or safety standards of its machines.
 - The information contained in this manual is based on machines manufactured up until the time of publication. Wacker Neuson reserves the right to change any portion of this information without notice.
 - The illustrations, parts, and procedures in this manual refer to Wacker Neuson factory-installed components. Your machine may vary depending on the requirements of your specific region.
-

CALIFORNIA Proposition 65 Warning

Combustion exhaust, some of its constituents, and certain vehicle components contain or emit chemicals known to the State of California to cause cancer and birth defects or other reproductive harm.

Laws pertaining to spark arresters

NOTICE: State Health Safety Codes and Public Resources Codes specify that in certain locations spark arresters be used on internal combustion engines that use hydrocarbon fuels. A spark arrester is a device designed to prevent accidental discharge of sparks or flames from the engine exhaust. Spark arresters are qualified and rated by the United States Forest Service for this purpose. In order to comply with local laws regarding spark arresters, consult the engine distributor or the local Health and Safety Administrator.

Manufacturer's approval

This manual contains references to *approved* parts, attachments, and modifications. The following definitions apply:

- **Approved parts or attachments** are those either manufactured or provided by Wacker Neuson.
- **Approved modifications** are those performed by an authorized Wacker Neuson service center according to written instructions published by Wacker Neuson.
- **Unapproved parts, attachments, and modifications** are those that do not meet the approved criteria.

Unapproved parts, attachments, or modifications may have the following consequences:

- Serious injury hazards to the operator and persons in the work area
- Permanent damage to the machine which will not be covered under warranty

Contact your Wacker Neuson dealer immediately if you have questions about approved or unapproved parts, attachments, or modifications.



EC Declaration of Conformity

Manufacturer

Wacker Neuson Production Americas LLC, N92W15000 Anthony Avenue,
Menomonee Falls, Wisconsin 53051 USA

Product

Product	PT2A, PT2H
Product category	Water Pump Units
Product function	To pump fluid
Item number	5000009095, 5000009097, 5000009237
Net installed power	PT 2A: 3.6 kW; PT 2H: 3.4 kW
Measured sound power level	PT 2A: 99 dB(A); PT 2H: 102 dB(A)
Guaranteed sound power level	PT 2A: 101 dB(A); PT 2H: 103 dB(A)

Conformity Assessment Procedure

According to 2000/14/EC ANNEX V

Directives and Standards

We hereby declare that this product meets and complies with the relevant regulations and requirements of the following directives and standards:
2006/42/EC, 2000/14/EC

Authorized Person for Technical Documents

Leo Goeschka, Wacker Neuson Produktion GmbH & Co. KG, Preußenstraße 41,
80809 München

Menomonee Falls, WI, USA, 24.08.15

Keith Herr
Vice President and Managing Director
For Wacker Neuson

Dan Domanski
Technical Director
For Wacker Neuson

Travis Pound
Manager, Product Engineering
For Wacker Neuson



EC Declaration of Conformity

Manufacturer

Wacker Neuson Production Americas LLC, N92W15000 Anthony Avenue,
Menomonee Falls, Wisconsin 53051 USA

Product

Product	PT3, PT3A, PT3H
Product category	Water Pump Units
Product function	To pump fluid
Item number	5000009101, 5000009240, 5000009103, 5000009322, 5000620800
Net installed power	PT 3: 6.6 kW; PT 3A: 5.9 kW; PT 3H: 5.0 kW
Measured sound power level	PT 3: 102 dB(A); PT 3A: 101 dB(A); PT 3H: 106 dB(A)
Guaranteed sound power level	PT 3: 103 dB(A); PT 3A: 102 dB(A); PT 3H: 106 dB(A)

Conformity Assessment Procedure

According to 2000/14/EC ANNEX V

Directives and Standards

We hereby declare that this product meets and complies with the relevant regulations and requirements of the following directives and standards:
2006/42/EC, 2000/14/EC

Authorized Person for Technical Documents

Leo Goeschka, Wacker Neuson Produktion GmbH & Co. KG, Preußenstraße 41,
80809 München

Menomonee Falls, WI, USA, 27.03.15

Keith Herr
Vice President and Managing Director
For Wacker Neuson

Dan Domanski
Technical Director
For Wacker Neuson

Travis Pound
Manager, Product Engineering
For Wacker Neuson

Foreword	3
EC Declaration of Conformity	5
EC Declaration of Conformity	7
1 Safety Information	11
1.1 Signal Words Used in this Manual	11
1.2 Machine Description and Intended Use	12
1.3 Safety Guidelines for Operating the Machine	13
1.4 Service Safety	15
1.5 Operator Safety while Using Internal Combustion Engines	17
2 Labels	18
2.1 Label Locations	18
2.2 Label Meanings	19
3 Lifting and Transporting	22
3.1 Lifting the Machine	22
3.2 Preparing the Machine for Transport on a Truck or Trailer	23
4 Operation	24
4.1 Preparing the Machine for First Use	24
4.2 Recommended Fuel	25
4.3 Recommended Fuel (Hatz powered machines only)	25
4.4 Refueling the Machine	26
4.5 Positioning and Preparing the Machine for Operation	27
4.6 Before Starting the Machine	28
4.7 Starting and Stopping the Machine (WM 170 / WM 270)	29
4.8 Starting and Stopping the Machine (Honda)	30
4.9 Starting and Stopping the Machine (Hatz)	31
4.10 Emergency Shutdown Procedure	32
5 General Maintenance	33
5.1 Maintaining the Emission Control System	33
5.2 Periodic Maintenance Schedule	33

5.3	Inspecting the Impeller	34
5.4	Storage	36
5.5	Machine Disposal and Decommissioning	37
6	Engine Maintenance: WM 130 / WM 170 / WM 270	38
7	Engine Maintenance: Honda GX160	40
8	Engine Maintenance: Honda GX390	42
9	Engine Maintenance: Hatz 1B 20 / 1B 30	44
10	Troubleshooting	47
11	Technical Data	48
11.1	Engine—PT2 / PT2(I) / PT2H / PT2H(I)	48
11.2	Engine—PT2A / PT2A(I)	49
11.3	Engine—PT3 / PT3A / PT3(I) / PT3H	50
11.4	Pump—PT2 / PT2(I) / PT2A / PT2H	51
11.5	Pump—PT3 / PT3(I) / PT3A / PT3H	51
11.6	Sound Measurements	52
11.7	Dimensions	53
12	Emission Control Systems Information and Warranty	55
12.1	Emission Control Systems Warranty Statement	55
13	AEM Safety Manual	57

1 Safety Information

1.1 Signal Words Used in this Manual

This manual contains DANGER, WARNING, CAUTION, *NOTICE*, and NOTE signal words which must be followed to reduce the possibility of personal injury, damage to the equipment, or improper service.



This is the safety alert symbol. It is used to alert you to potential personal hazards.
▶ Obey all safety messages that follow this symbol.



DANGER

DANGER indicates a hazardous situation which, if not avoided, will result in death or serious injury.

- ▶ To avoid death or serious injury from this type of hazard, obey all safety messages that follow this signal word.
-



WARNING

WARNING indicates a hazardous situation which, if not avoided, could result in death or serious injury.

- ▶ To avoid possible death or serious injury from this type of hazard, obey all safety messages that follow this signal word.
-



CAUTION

CAUTION indicates a hazardous situation which, if not avoided, could result in minor or moderate injury.

- ▶ To avoid possible minor or moderate injury from this type of hazard, obey all safety messages that follow this signal word.
-

NOTICE: Used without the safety alert symbol, NOTICE indicates a situation which, if not avoided, could result in property damage.

Note: A Note contains additional information important to a procedure.

1.2 Machine Description and Intended Use

This machine is a centrifugal trash pump. The Wacker Neuson Trash Pump consists of a tubular steel frame surrounding a gasoline or diesel engine, a fuel tank, and an impeller pump with ports for water suction and discharge. The engine rotates the impeller during operation. Waste water is drawn into the pump through the suction port and expelled through the discharge port. The operator connects hoses to the pump and routes them so that water and solids are drained from the work area and discharged into an appropriate location.

This machine is intended to be used for general de-watering applications. This machine is intended for the pumping of clear water, or water containing solids up to the size stated within the product specifications, and up to the flow, head, and suction lift limits also stated within the product specifications.

This machine has been designed and built strictly for the intended use described above. Using the machine for any other purpose could permanently damage the machine or seriously injure the operator or other persons in the area. Machine damage caused by misuse is not covered under warranty.

The following are some examples of misuse:

- Pumping flammable, explosive, or corrosive fluids
 - Pumping hot or volatile fluids that result in pump cavitation
 - Operating the pump outside of product specifications due to incorrect diameter hoses, incorrect length hoses, other inlet or outlet restrictions, or excessive suction lift or head
 - Using the machine as a ladder, support, or work surface
 - Operating the machine outside of factory specifications
 - Operating the machine in a manner inconsistent with all warnings found on the machine and in the Operator's Manual
-

This machine has been designed and built in accordance with the latest global safety standards. It has been carefully engineered to eliminate hazards as far as practicable and to increase operator safety through protective guards and labeling. However, some risks may remain even after protective measures have been taken. They are called residual risks. On this machine, they may include exposure to:

- Heat, noise, exhaust, and carbon monoxide from the engine
- Fire hazards from improper refueling techniques
- Fuel and its fumes
- Personal injury from improper lifting techniques
- Projectile hazard from discharge
- Crushing hazards from a tipping or falling pump

To protect yourself and others, make sure you thoroughly read and understand the safety information presented in this manual before operating the machine.

1.3 Safety Guidelines for Operating the Machine

Operator training

Before operating the machine:

- Read and understand the operating instructions contained in all manuals delivered with the machine.
- Familiarize yourself with the location and proper use of all controls and safety devices.
- Contact Wacker Neuson for additional training if necessary.

When operating this machine:

- Do not allow improperly trained people to operate the machine. People operating the machine must be familiar with the potential risks and hazards associated with it.

Operator qualifications

Only trained personnel are permitted to start, operate, and shut down the machine. They also must meet the following qualifications:

- have received instruction on how to properly use the machine
- are familiar with required safety devices

The machine must not be accessed or operated by:

- children
- people impaired by alcohol or drugs

Application area

Be aware of the application area.

- Keep unauthorized personnel, children, and pets away from the machine.
- Remain aware of changing positions and the movement of other equipment and personnel in the application area/job site.
- Identify whether special hazards exist in the application area, such as toxic gases or unstable ground conditions, and take appropriate action to eliminate the special hazards before using the machine.

Be aware of the application area.

- Do not operate the machine in areas that contain flammable objects, fuels, or products that produce flammable vapors.

Safety devices, controls, and attachments

Only operate the machine when:

- All safety devices and guards are in place and in working order.
- All controls operate correctly.
- The machine is set up correctly according to the instructions in the Operator's Manual.
- The machine is clean.
- The machine's labels are legible.

To ensure safe operation of the machine:

- Do not operate the machine if any safety devices or guards are missing or inoperative.
- Do not modify or defeat the safety devices.
- Only use accessories or attachments that are approved by Wacker Neuson.

Safe operating practices

When operating this machine:

- Remain aware of the machine's moving parts. Keep hands, feet, and loose clothing away from the machine's moving parts.

When operating this machine:

- Do not operate a machine in need of repair.
-

Personal Protective Equipment (PPE)

Wear the following Personal Protective Equipment (PPE) while operating this machine:

- Close-fitting work clothes that do not hinder movement
 - Safety glasses with side shields
 - Hearing protection
 - Safety-toed footwear
-

Safe operating practices

- Do not open the priming plug when the pump is hot. Do not loosen or remove inlet or discharge hose fittings when the pump is hot. Hot water inside could be pressurized much like the radiator on an automobile. Allow the pump to cool to the touch before loosening the plug and before loosening or removing the inlet or discharge hose fittings.
- Do not position the pump on a loose, uneven, or unstable surface where it can tip, roll, slide or fall! The pump must be secure before operating. Position the pump on a firm and flat surface
- Do not open the pump housing cover while the pump is operating or start the pump with the cover off. The rotating impeller inside the pump can cut or sever objects caught in it.
- Do not block or restrict flow from the inlet line or the discharge line. Remove kinks from the discharge line before starting the pump. Operation with a blocked inlet line or discharge line can cause water inside the pump to overheat.
- Do not reach into or insert anything into the pump while the engine is on! The impeller inside the pump housing is turning at all times while the engine is running.
- Do not allow anyone to stand in front of the discharge port when starting the engine or while priming the pump! The sudden out-rush of water could push or knock a person down.
- Always make sure the hose connections on the pump are tight. A loose connection could cause water to spray or result in a hose falling off the pump while it is in operation.
- Always make sure the water stream from the pump discharge is not directed in such a way so as to cause erosion to the surrounding ground or damage or weakening of nearby structures!

1.4 Service Safety

Service training

Before servicing or maintaining the machine:

- Read and understand the instructions contained in all manuals delivered with the machine.
- Familiarize yourself with the location and proper use of all controls and safety devices.
- Only trained personnel shall troubleshoot or repair problems occurring with the machine.
- Contact Wacker Neuson for additional training if necessary.

When servicing or maintaining this machine:

- Do not allow improperly trained people to service or maintain the machine. Personnel servicing or maintaining the machine must be familiar with the associated potential risks and hazards.

Precautions

When servicing or maintaining the machine:

- Read and understand the service procedures before performing any service to the machine.
- All adjustments and repairs must be completed before operating the machine. Do not operate the machine with a known problem or deficiency.
- All repairs and adjustments shall be completed by a qualified technician.
- Turn off the machine before performing maintenance or making repairs.
- Remain aware of the machine's moving parts. Keep hands, feet, and loose clothing away from the machine's moving parts.
- Re-install the safety devices and guards after repair and maintenance procedures are complete.

Machine modifications

When servicing or maintaining the machine:

- Use only accessories/attachments that are approved by Wacker Neuson.

When servicing or maintaining the machine:

- Do not defeat safety devices.
- Do not modify the machine without the express written approval of Wacker Neuson.

Replacing parts and labels

- Replace worn or damaged components.
- Replace all missing and hard-to-read labels.
- When replacing electrical components, use components that are identical in rating and performance to the original components.
- When replacement parts are required for this machine, use only Wacker Neuson replacement parts or those parts equivalent to the original in all types of specifications, such as physical dimensions, type, strength, and material.

Cleaning

When cleaning and servicing the machine:

- Keep the machine clean and free of debris such as leaves, paper, cartons, etc.
- Keep the labels legible.

When cleaning the machine:

- Do not clean the machine while it is running.
 - Never use gasoline or other types of fuels or flammable solvents to clean the machine. Fumes from fuels and solvents can become explosive.
-

Personal Protective Equipment (PPE)

Wear the following Personal Protective Equipment (PPE) while servicing or maintaining this machine:

- Close-fitting work clothes that do not hinder movement
- Safety glasses with side shields
- Hearing protection
- Safety-toed footwear

In addition, before servicing or maintaining the machine:

- Tie back long hair.
 - Remove all jewelry (including rings).
-

After Use

- Stop the engine when the machine is not being operated.
- Close the fuel valve on engines equipped with one when machine is not being operated.
- Ensure that the machine will not tip over, roll, slide, or fall when not being operated.
- Store the machine properly when it is not being used. The machine should be stored in a clean, dry location out of the reach of children.

1.5 Operator Safety while Using Internal Combustion Engines



WARNING

Internal combustion engines present special hazards during operation and fueling. Failure to follow the warnings and safety standards could result in severe injury or death.

- ▶ Read and follow the warning instructions in the engine owner's manual and the safety guidelines below.



DANGER

Exhaust gas from the engine contains carbon monoxide, a deadly poison. Exposure to carbon monoxide can kill you in minutes.

- ▶ NEVER operate the machine inside an enclosed area, such as a tunnel, unless adequate ventilation is provided through such items as exhaust fans or hoses.

Operating safety

When running the engine:

- Keep the area around the exhaust pipe free of flammable materials.
- Check the fuel lines and the fuel tank for leaks and cracks before starting the engine. Do not run the machine if fuel leaks are present or the fuel lines are loose.

When running the engine:

- Do not smoke while operating the machine.
- Do not run the engine near sparks or open flames.
- Do not touch the engine or muffler while the engine is running or immediately after it has been turned off.
- Do not operate a machine when its fuel cap is loose or missing.
- Do not start the engine if fuel has spilled or a fuel odor is present. Move the machine away from the spill and wipe the machine dry before starting.

Refueling safety

When refueling the engine:

- Clean up any spilled fuel immediately.
- Refill the fuel tank in a well-ventilated area.
- Re-install the fuel tank cap after refueling.
- Do not smoke.
- Do not refuel a hot or running engine.
- Do not refuel the engine near sparks or open flames.
- Use suitable tools for refueling (for example, a fuel hose or a funnel).
- Do not refuel if the machine is positioned in a truck fitted with a plastic bed liner. Static electricity can ignite the fuel or fuel vapors.



2 Labels

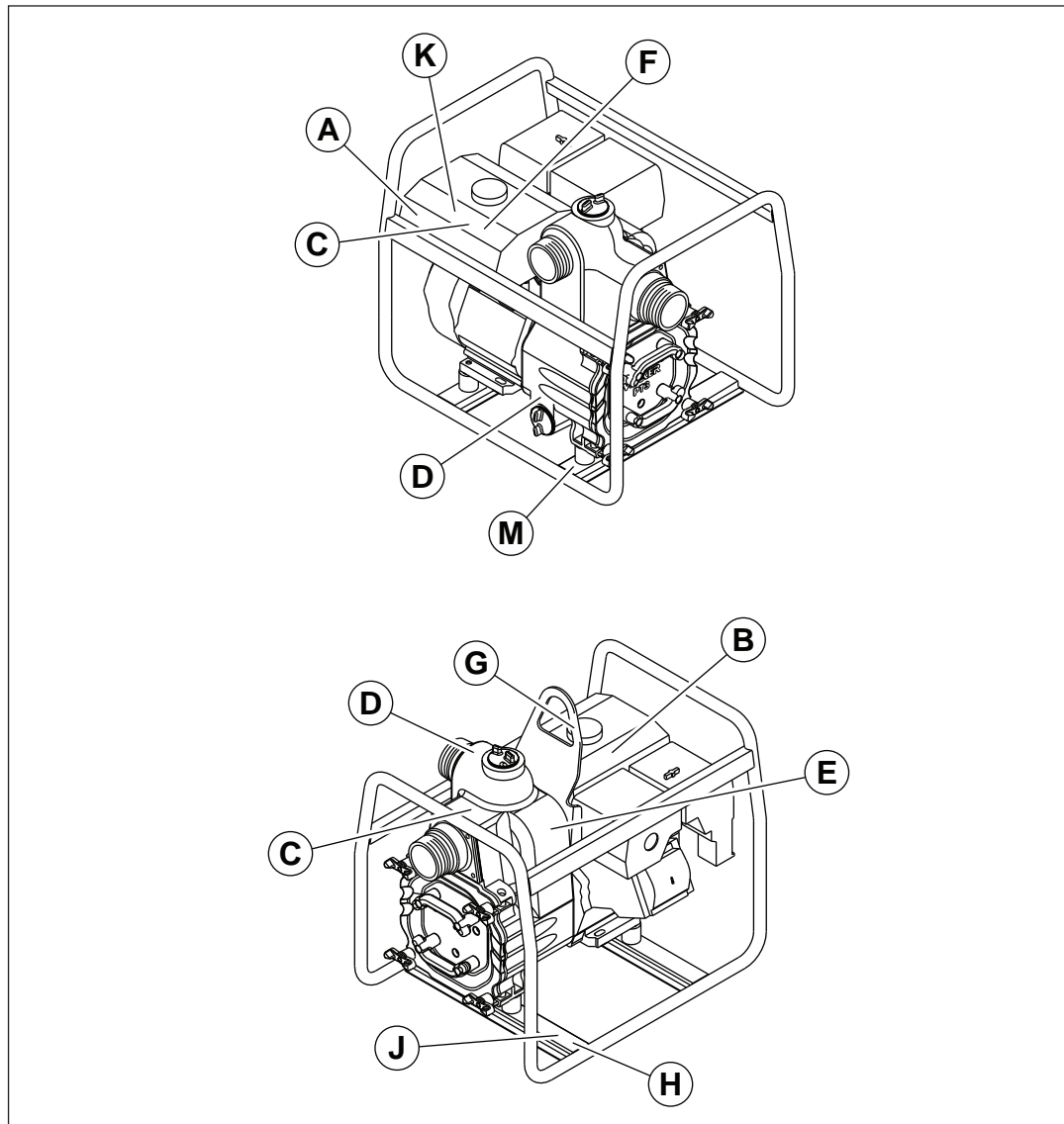





2.1 Label Locations

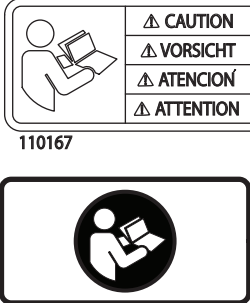



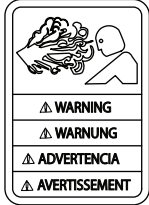

wc_gr012671

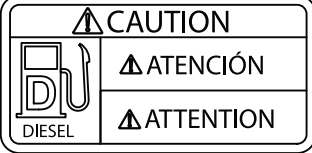
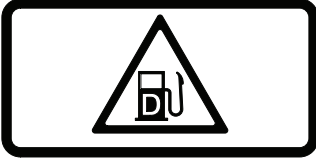
2.2 Label Meanings

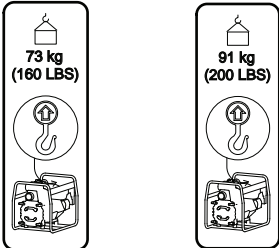
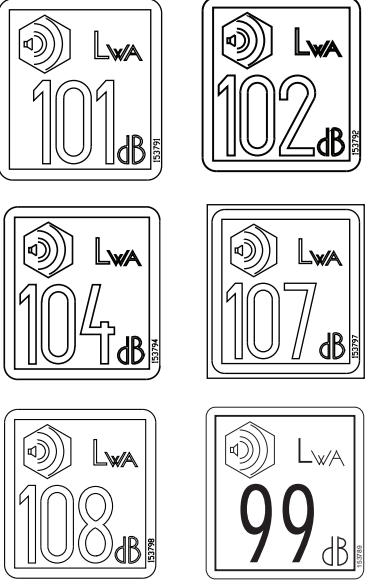
<p>A</p>	 <p>117034 HONDA</p> <p>178715</p>	<p>DANGER Asphyxiation hazard.</p> <ul style="list-style-type: none"> ■ Engines emit carbon monoxide. ■ Do not run the machine indoors or in an enclosed area. ■ NEVER use inside a home or garage, EVEN IF doors and windows are open. ■ Only use OUTSIDE and far away from windows, doors, and vents. ■ Read the Operator's Manual. ■ No sparks, flames, or burning objects near the machine. ■ Stop the engine before refueling. ■ Use only clean, filtered diesel fuel.
<p>B</p>	 <p>117039</p> <p>178713</p>	<p>WARNING Hot surface</p>
<p>C</p>	 <p>110167</p> <p>178714</p>	<p>CAUTION Read and understand the supplied Operator's Manual before operating this machine. Failure to do so increases the risk of injury to yourself and others.</p>

<p>D</p>	 <p>110164</p>  <p>5100015564</p>  <p>110164</p>  <p>5100015565</p>	<p>WARNING Pressurized contents. Do not open when hot!</p>
<p>E</p>	 <p>151049</p>  <p>178764</p>	<p>WARNING Never pump volatile, flammable, or low-flash-point fluids. These fluids could ignite or explode.</p>
<p>F</p>	 <p>116679</p>  <p>181145</p>	<p>CAUTION Use only clean, filtered diesel fuel (Hatz powered machines only)</p>

<p>G</p>		<p>NOTICE Lifting point</p>
<p>H</p>		<p>Guaranteed sound power level in dB(A)</p>
<p>J</p>		<p>Certified Performance Contractors Pump Bureau A Bureau of AEM The manufacturer of this pump certifies that it was manufactured in accordance with the standards of the Contractors Pump Bureau.</p>
<p>K</p>		<p>WARNING Operation of this equipment may create sparks that can start fires around dry vegetation. A spark arrester may be required. The operator should contact local fire agencies for laws or regulations relating to fire prevention requirements.</p>
<p>M</p>		<p>This machine may be covered by one or more patents.</p>

3 Lifting and Transporting

3.1 Lifting the Machine

- Requirements**
- Lifting equipment (crane, hoist, or fork truck) capable of supporting the machine's weight
 - Lifting devices (hooks, chains, and shackles) capable of supporting the machine's weight
 - Engine stopped

Lifting the machine

A lifting eye is used for lifting the machine.

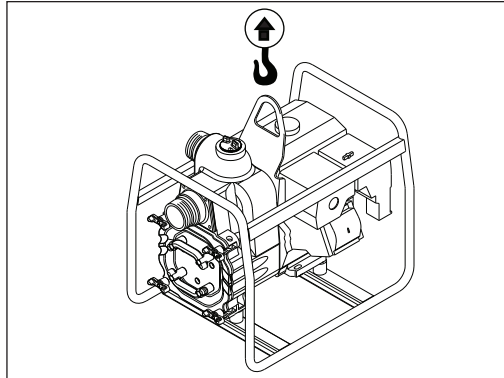

wc_gr012660

Perform the procedure below to lift the machine.

1. Attach the lifting devices and equipment to the lifting eye. Do not attach lifting devices to any other part of the machine.
2. Lift the machine a small distance.



WARNING

Crushing hazard. An unstable machine may cause the lifting devices and equipment to fail. You may be crushed if the lifting devices and equipment fail.

- ▶ Check for stability before continuing.

3. Check for stability. If necessary, lower the machine, reposition the lifting devices, and lift the machine a small distance again.
4. Continue lifting the machine only when it is stable.

3.2 Preparing the Machine for Transport on a Truck or Trailer

- Requirements**
- Machine stopped
 - Flatbed truck or trailer capable of supporting the machine's weight
 - Chains, hooks, or straps capable of supporting the machine's weight
-

- Checklist**
- Before transporting the machine, check the following items:
- Check that the transport vehicle or trailer can support the weight of the machine.
 - Check that the transport vehicle or trailer is wide enough to support the machine.
 - Check that the wheels of the transport vehicle or trailer are chocked during the loading process.
 - Check that the transport vehicle or trailer is clean and free of grease, oil, ice, and other loose material.
 - Check that any ramps used in the loading process:
 - Can support the weight of the machine.
 - Are clean and free of grease, oil, ice, and other loose material.
 - Are securely connected to the transport vehicle or trailer.
 - Are of sufficient length to keep the loading angle 15° or less.
- In addition:**
- Check that the loading area is flat and the ground is stable.
 - Check the overall height of the machine once it is loaded on the truck or trailer.
 - Plan your travel route so there will be adequate clearance for overpasses, road signs, buildings, etc.
 - Check local regulations regarding transporting and obey these regulations.

4 Operation**4.1 Preparing the Machine for First Use**

1. Make sure all loose packaging materials have been removed from the machine.
2. Check the machine and its components for damage. If there is visible damage, do not operate the machine! Contact your Wacker Neuson dealer immediately for assistance.
3. Take inventory of all items included with the machine and verify that all loose components and fasteners are accounted for.
4. Attach component parts not already attached.
5. Add fluids as needed and applicable, such as fuel and engine oil.
6. Move the machine to its operating location.

4.2 Recommended Fuel

The engine requires regular grade unleaded gasoline. Use only fresh, clean gasoline. Gasoline containing water or dirt will damage the fuel system. Consult the engine owner's manual for complete fuel specifications.

Use of oxygenated fuels

Some conventional gasolines are blended with alcohol. These gasolines are collectively referred to as oxygenated fuels. If you use an oxygenated fuel, be sure it is unleaded and meets the minimum octane rating requirement.

Before using an oxygenated fuel, confirm the fuel's contents. Some states and provinces require this information to be posted on the fuel pump.

The following is the Wacker Neuson approved percentage of oxygenates:

ETHANOL - (ethyl or grain alcohol) 10% by volume. You may use gasoline containing up to 10% ethanol by volume (commonly referred to as E10). Gasoline containing more than 10% ethanol (such as E15, E20, or E85) may not be used because it could damage the engine.

If you notice any undesirable operating symptoms, try another service station, or switch to another brand of gasoline.

Fuel system damage or performance problems resulting from the use of an oxygenated fuel containing more than the percentages of oxygenates mentioned above are not covered under warranty.

4.3 Recommended Fuel (Hatz powered machines only)

Low temperatures cause diesel fuel to gel. Always use the proper fuel for the conditions. Follow the guidelines in the table below.

Lowest expected ambient temperature	Recommended fuel ¹
Above freezing > 0°C (32°F)	#2 diesel plus additives
Below freezing < 0°C (32°F)	Winter-blend diesel

¹Your engine may require ultra low sulfur fuel. Consult the engine owner's manual.



CAUTION
Fire hazard.

► Do not use gasoline, crankcase oil, or any oil containing gasoline.

4.4 Refueling the Machine

- Requirements**
- Machine shut down
 - Engine cool
 - Machine/fuel tank level with the ground
 - Fresh, clean fuel supply

Procedure Perform the procedure below to refuel the machine.



WARNING

Fire hazard. Fuel and its vapors are extremely flammable. Burning fuel can cause severe burns.

- ▶ Keep all sources of ignition away from the machine while refueling.
 - ▶ Do not refuel if the machine is positioned in a truck fitted with a plastic bed liner. Static electricity can ignite the fuel or fuel vapors.
 - ▶ Refuel only when the machine is outdoors.
 - ▶ Clean up spilled fuel immediately.
-

1. Remove the fuel cap **(a)**.

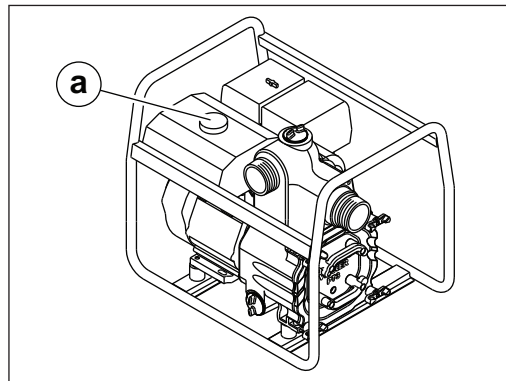

wc_gr012714

2. Fill the fuel tank to the base of the neck.



CAUTION

Fire and health hazard. Fuel expands when heated. Expanding fuel in an over-filled tank can lead to spills and leaks.

- ▶ Do not overfill the fuel tank.
-

3. Re-install the fuel cap.
-

Result The procedure to refuel the machine is now complete.

4.5 Positioning and Preparing the Machine for Operation



WARNING

Personal injury hazard. Failure to follow the listed procedures may cause injury to personnel or damage to the machine.

- ▶ All persons setting up the machine must be fully trained on the installation of the machine.

Pre-operation setup

Perform the procedure below to position and prepare the machine for operation.

1. Position the pump as near to the water as possible, on a firm, flat surface. Keep the pump level.
2. Connect the suction hose **(a)** to the suction port **(b)**.
 - Suction hoses must be rigid enough not to collapse.
 - At least two T-bolt clamps are recommended for connecting the suction hose to the suction port. Position the hose clamps at 90° intervals for best seal.

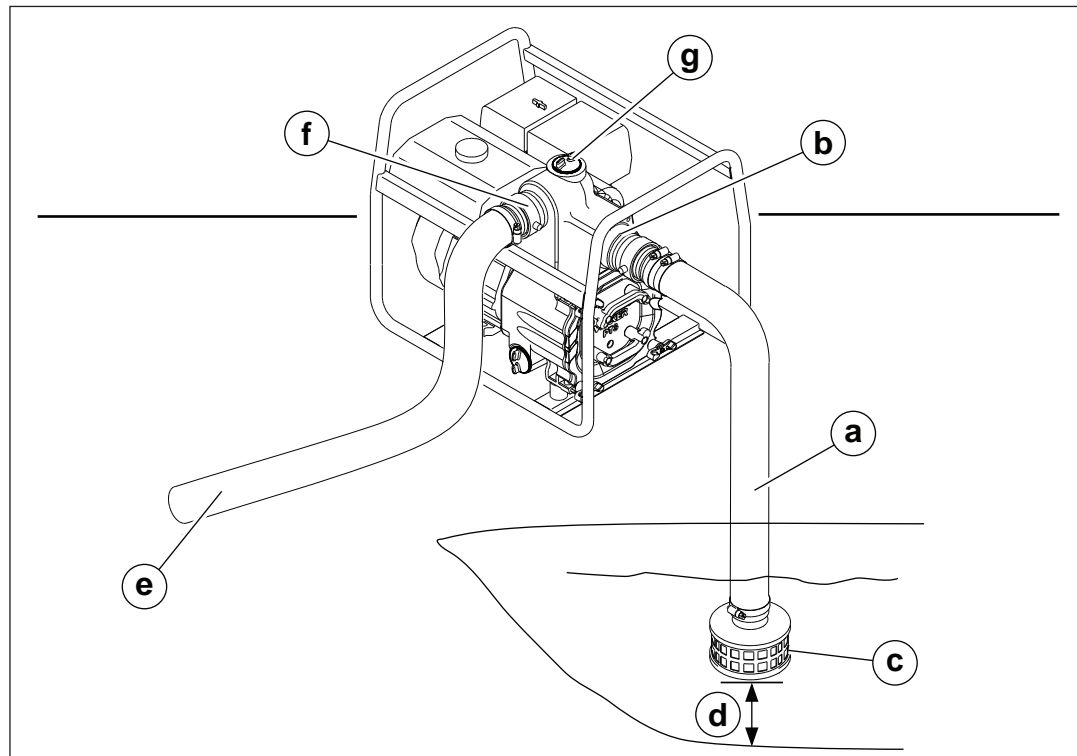

wc_gr012715



WARNING

Personal injury hazard. A loose connection between the suction hose and the suction port can result in personal injury should the suction hose break loose while the pump is operating.

- ▶ Only operate the machine when the suction hose is securely fastened to the suction port.

This procedure continues on the next page.

Continued from the previous page.

3. Connect the strainer **(c)** to the suction hose.
 - Always use a strainer on the end of the suction hose to prevent pulling in large debris which could clog the pump or jam the impeller.
 - Do not use a strainer with holes larger than the maximum solid-size rating of the pump.

Machine	Maximum solid-size rating
PT2	25 mm (1.0 in.)
PT3	38 mm (1.5 in.)

4. Submerge the suction hose.
 - Do not place the strainer directly into mud or sand. Always keep the strainer suspended **(d)** in the liquid being pumped.
5. Connect the discharge hose **(e)** to the discharge port **(f)**.
Note: *Lay the discharge hose as straight as possible. Avoid sharp bends and turns.*
6. Prime the pump. To do so:
 - a. Remove the priming plug **(g)**.
 - b. With the suction hose submerged, fill the pump housing with water.
 - c. Close the priming plug.

4.6 Before Starting the Machine

Before starting the machine, perform each item on the following checklist.

Pre-operation checks

- Read and understand the engine owner’s manual.
- Review and follow the safety instructions found in the front of this Operator’s Manual.

External checks

- Check the suction hose and discharge hose for holes or tears.
- Make sure that the hose couplings and hose clamps are attached.
- Check that the priming plug is closed.
- Check the tightness of the external fasteners—tighten the external fasteners as necessary.

Internal checks

- Check engine oil and fuel levels—fill as required.
- Check the condition of the air cleaner—remove debris or replace air cleaner.

4.7 Starting and Stopping the Machine (WM 170 / WM 270)

- Requirements**
- Suction and discharge hoses properly attached and positioned
 - There is fuel in the tank

Starting the machine

Perform the procedure below to start the machine.

1. Set the fuel valve to the open position (**a₁**).

Note: If the engine is cold, set the choke lever to the closed position (**b₁**). If the engine is hot, set the choke lever to the open position (**b₂**).

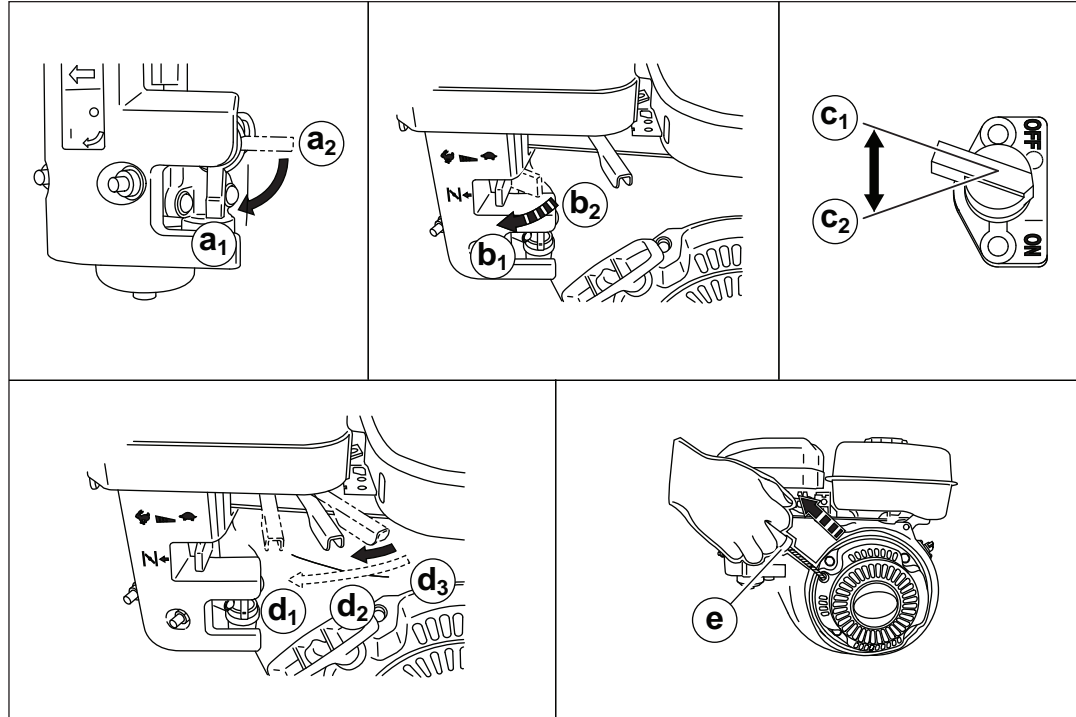

wc_gr012716

2. Turn the engine start switch to the "ON" position (**c₁**).
 3. Move the throttle lever slightly to the left (**d₂**), about 1/3 of the way toward the high speed position (**d₁**).
 4. Pull the starter rope (**e**).
- Note:** If the oil level in the engine is low, the engine will not start. If this happens, add oil to the engine.
5. Open the choke (**b₁**) as the engine warms.
 6. Set the throttle lever to the high speed position (**d₁**) to operate the machine.

Stopping the machine

Perform the procedure below to stop the machine.

1. Set the throttle lever to the slow/idle position (**d₃**) to reduce engine RPM.
2. Turn engine start switch to the "OFF" position (**c₂**).
3. Set the fuel valve to the closed position (**a₂**).

4.8 Starting and Stopping the Machine (Honda)

- Requirements**
- Suction and discharge hoses properly attached and positioned
 - There is fuel in the tank

Starting the machine

Perform the procedure below to start the machine.

1. Set the fuel valve to the open position (**a₁**).
- Note:** If the engine is cold, set the choke lever to the closed position (**b₁**). If the engine is hot, set the choke lever to the open position (**b₂**).

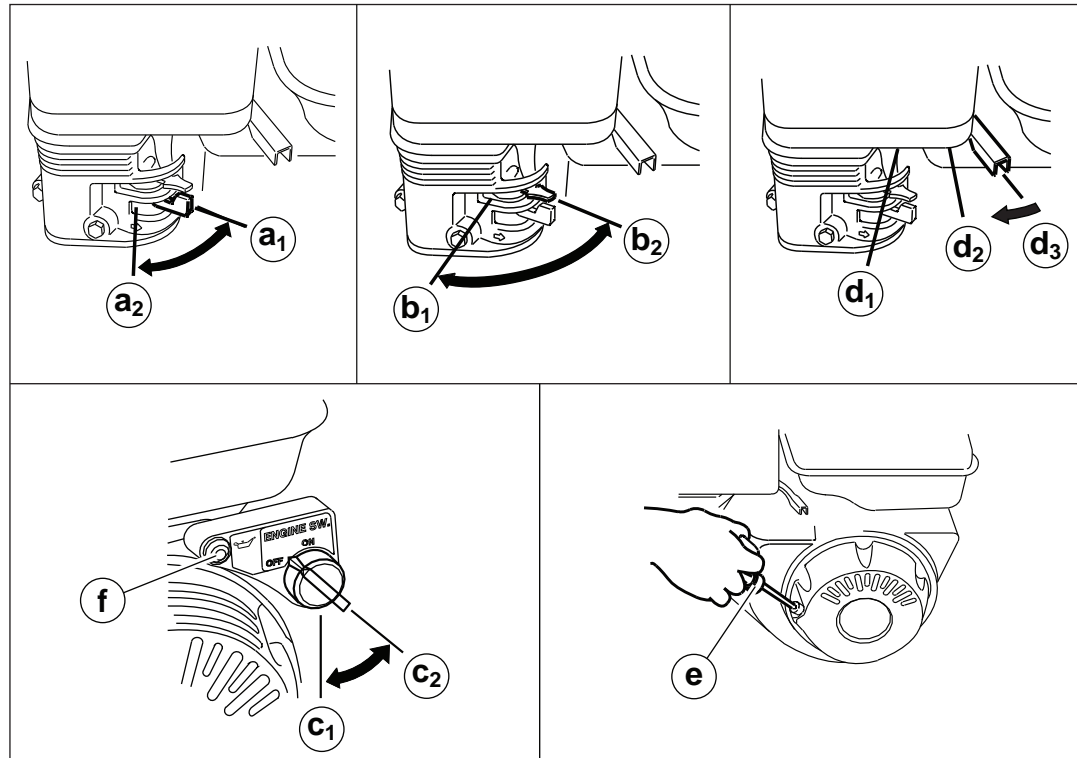

wc_gr012718

2. Turn the engine start switch to the “ON” position (**c₁**).
 3. Move the throttle lever slightly to the left (**d₂**), about 1/3 of the way toward the high speed position (**d₁**).
 4. Pull the starter rope (**e**).
- Note:** If the oil level in the engine is low, the engine will not start. If this happens, add oil to the engine. Your engine may be equipped with an oil alert light (**f**) that will illuminate while pulling the starter rope.
5. Open the choke (**b₁**) as the engine warms.
 6. Set the throttle lever to the high speed position (**d₁**) to operate the machine.

Stopping the machine

Perform the procedure below to stop the machine.

1. Set the throttle lever to the slow/idle position (**d₃**) to reduce engine RPM.
2. Turn engine start switch to the “OFF” position (**c₂**).
3. Set the fuel valve to the closed position (**a₂**).

4.9 Starting and Stopping the Machine (Hatz)

- Requirements**
- Suction and discharge hoses properly attached and positioned
 - There is fuel in the tank

Starting the machine

Perform the procedure below to start the machine.

1. Set the engine speed control lever **(a)** to the 1/2 START or START position, as desired or necessary.

Note: Starting the engine at a lower speed will help to prevent exhaust smoke.

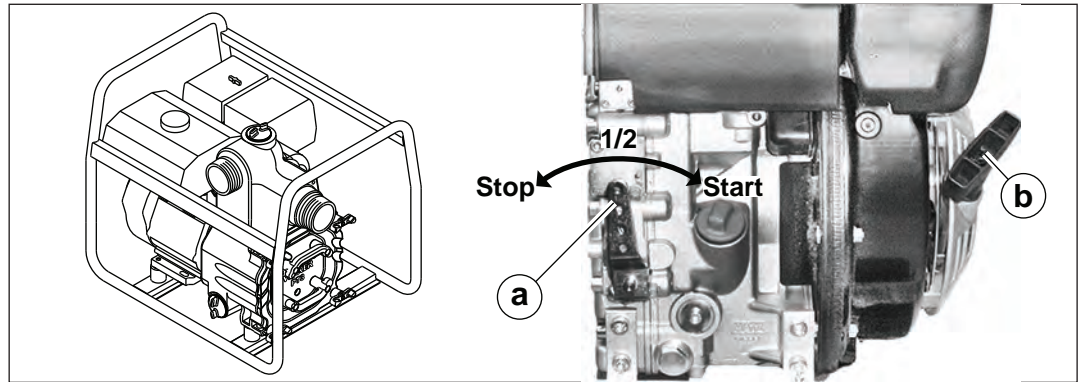

2. Pull the starter rope **(b)** lightly until you feel slight resistance.
3. Allow the recoil starter to pull the starter rope back in. This allows the entire length of the starter rope to be used to start the engine.
4. Grip the starter rope handle with both hands.
5. Pull the starter rope briskly. Repeat until the engine starts.

Note: If after several attempts to start the engine and exhaust begins to emit white smoke, move the speed control lever to the STOP position. Then, pull the starter rope out slowly 5 times. Repeat the starting the machine procedure at step 1.

Stopping the machine

Set the engine speed control lever to the STOP position.

4.10 Emergency Shutdown Procedure

Perform the procedure below if a breakdown or accident occurs while the machine is operating.

1. Stop the engine.
2. Remove the obstruction.
3. Un-kink the hoses.
4. Allow the machine to cool.
5. Contact the rental yard or machine owner.

5 General Maintenance



WARNING

A poorly maintained machine can malfunction, causing injuries or permanent damage to the machine.

- ▶ Keep the machine in safe operating condition by performing periodic maintenance and making repairs as needed.

5.1 Maintaining the Emission Control System

For machines sold in North America:

Normal maintenance, replacement, or repair of emission control devices and systems may be performed by any repair establishment or individual; however, warranty repairs must be performed by a dealer/service center authorized by Wacker Neuson. The use of service parts that are not equivalent in performance and durability to authorized parts may impair the effectiveness of the emission control system and may have a bearing on the outcome of a warranty claim.

5.2 Periodic Maintenance Schedule

The table below lists basic machine and engine maintenance. Tasks designated with check marks may be performed by the operator. Tasks designated with square bullet points require special training and equipment.

Refer to the engine owner's manual for additional information.

	Daily before starting
Check external hardware.	✓
Open pump housing cover and remove any debris from inside of pump housing.	✓
Inspect for leaks between pump and engine.	✓
Check the condition of the fuel tank cap and drain plug cap.	✓
Check housing cover O-rings.	■
Inspect shockmounts for damage.	■

5.3 Inspecting the Impeller

Background Sand, dirt, and debris will cause the impeller to wear. If the pump's performance drops over time, check and adjust the clearance between the impeller and the insert.

- Requirements**
- Machine shut down
 - Bleach and source of clean water
 - Shims (if needed)



WARNING

Personal injury hazard.

- ▶ Do not reach into or insert anything into the pump while the engine is running.
- ▶ Do not run the pump with the pump housing cover removed.

Procedure Perform the procedure below to inspect the impeller.

1. Open the drain plug **(a)** and drain the pump.

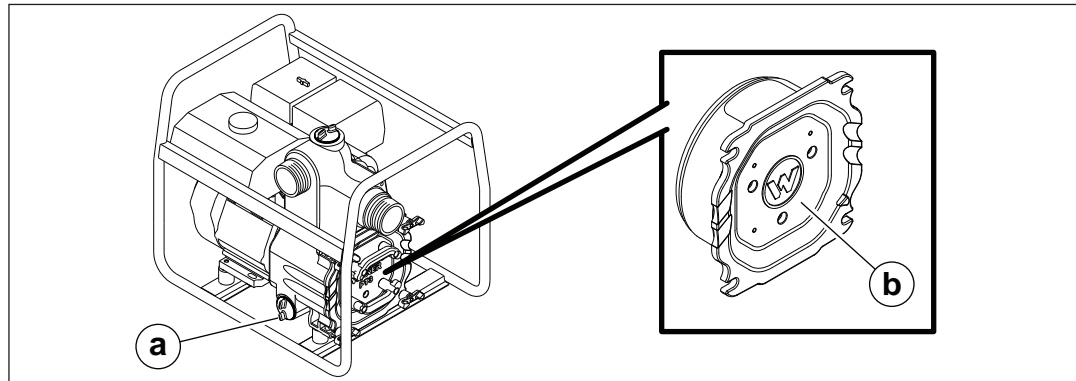

wc_gr012673

2. Remove the pump housing cover **(b)** from the front of the pump.



WARNING

Personal injury hazard. Impeller edges can become sharp.

- ▶ Use care when working on the pump to reduce the risk of being cut.

This procedure continues on the next page.

Continued from the previous page.

3. Remove the volute (**c**) and clean the impeller (**d**) with a 50-50 mixture of bleach and water before working on it.

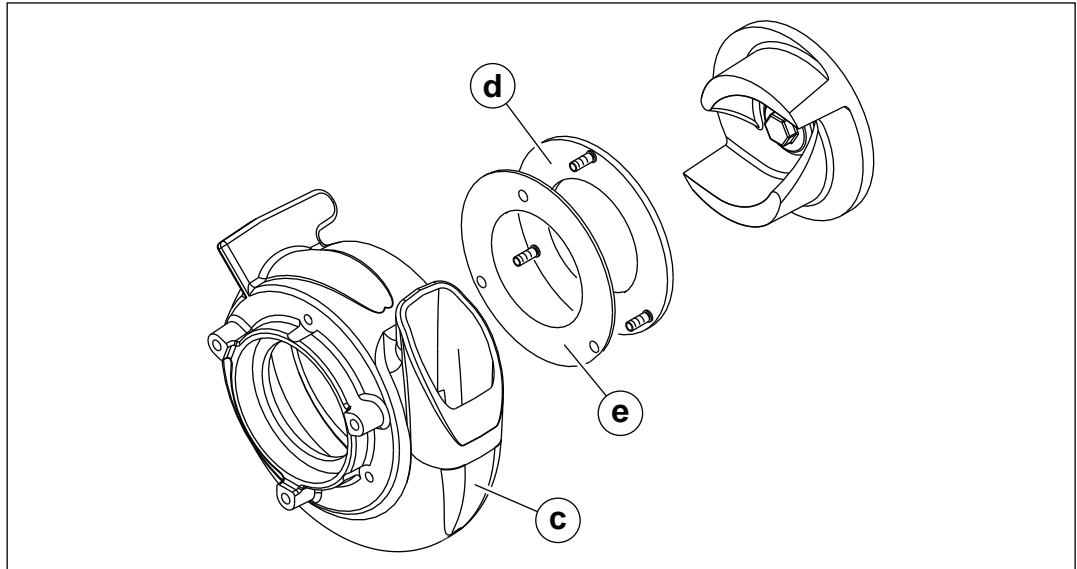

wc_gr012674

4. Check clearance between the impeller and the insert by slowly pulling the starter rope to turn the impeller. If starter rope is difficult to pull, or rubbing is heard from inside pump, the impeller and insert are too close to each other. Remove a shim (**e**) from behind the insert and check again for rubbing. Continue removing shims until the impeller turns easily.

Note:

- It is important not to remove too many shims or the clearance between the impeller and the insert will become too wide and pump performance will be reduced.
- As the impeller wears down, additional shims may be required to maintain the clearance between the impeller and the insert.

5. Re-install the pump housing cover.

Result

The impeller has now been inspected.

5.4 Storage

Introduction Extended storage of equipment requires preventive maintenance. Performing these steps helps to preserve machine components and ensures the machine will be ready for future use. While not all of these steps necessarily apply to this machine, the basic procedures remain the same.

When Prepare your machine for extended storage if it will not be operated for 30 days or more.

Preparing for storage Follow the procedures below to prepare your machine for storage.

- Complete any needed repairs.
- Replenish or change oils (engine, exciter, seal and bearing housings, and gearcase) per the intervals specified in the Periodic Maintenance Schedule.
- Grease all fittings and, if applicable, repack bearings.
- Inspect engine coolant. Replace coolant if it appears cloudy, is more than two seasons old, or does not meet the average lowest temperature for your area.
- If your machine has an engine equipped with a fuel valve, start the engine, close the fuel valve, and run the engine until it stops.
- Flush the pump and the hose lines by pumping clean water for a few minutes. If the pump was used for pumping salt water, be sure to use fresh water when flushing it.
- Remove the covers and clean the pump's interior. Wipe or spray all interior surfaces with a rust-inhibiting oil.
- Consult the engine owner's manual for instructions on preparing the engine for storage.

Stabilizing the fuel After completing the procedures listed above, fill the fuel tank completely and add a high-quality stabilizer to the fuel.

- Choose a stabilizer that includes cleaning agents and additives designed to coat/protect the cylinder walls.
- Make sure the stabilizer you use is compatible with the fuel in your area, fuel type, grade and temperature range. Do not add extra alcohol to fuels which already contain it (for example, E10).
- For engines with diesel fuel, use a stabilizer with a biocide to restrict or prevent bacteria and fungus growth.
- Add the correct amount of stabilizer per the manufacturer's recommendations.

Storing the machine Perform these remaining steps to store your machine.

- Wash the machine and allow it to dry.
- Move the machine to a clean, dry, secure storage location. Block or chock wheels to prevent machine movement.
- Use touch-up paint as needed to protect exposed metal against rust.
- If the machine has a battery, either remove or disconnect it.

NOTICE: Allowing the battery to freeze or completely discharge is likely to cause permanent damage. Periodically charge the battery while the machine is not in use. In cold climates, store and charge the battery indoors or in a warm location.

- Cover the machine. Tires and other exposed rubber items should be protected from the weather. Either cover them or use a readily available protectant.

5.5 Machine Disposal and Decommissioning

Introduction This machine must be properly decommissioned at the end of its service life. Responsible disposal of recyclable components, such as plastic and metal, ensures that these materials can be reused—conserving landfill space and valuable natural resources.

Responsible disposal also prevents toxic chemicals and materials from harming the environment. The operating fluids in this machine, including fuel, engine oil, and grease, may be considered hazardous waste in many areas. Before decommissioning this machine, read and follow local safety and environmental regulations pertaining to the disposal of construction equipment.

Preparation Perform the following tasks to prepare the machine for disposal.

- Move the machine to a protected location where it will not pose any safety hazards and cannot be accessed by unauthorized individuals.
- Ensure that the machine cannot be operated from the time of final shutdown to disposal.
- Drain all fluids, including fuel, engine oil, and coolant.
- Seal any fluid leaks.

Disposal Perform the following tasks to dispose of the machine.

- Disassemble the machine and separate all parts by material type.
- Dispose of recyclable parts as specified by local regulations.
- Dispose of all non-hazardous components that cannot be recycled.
- Dispose of waste fuel, oil, and grease in accordance with local environmental protection regulations.

Engine Maintenance: WM 130 / WM 170 / WM 270

6 Engine Maintenance: WM 130 / WM 170 / WM 270

The viscosity of the engine oil is an important factor when determining the correct engine oil to use in your machine. Use an engine oil of appropriate viscosity based on the expected outside air temperature. See the table below.



WARNING

Most used liquids from this machine such as oil, gasoline, grease, etc., contain small amounts of materials that can cause cancer and other health problems if inhaled, ingested, or left in contact with skin for prolonged periods of time.

- ▶ Take steps to avoid inhaling or ingesting used liquids.
- ▶ Wash skin thoroughly after exposure to used liquids.

CLASSIFICATION BY OIL VISCOSITY

SAE (Society of Automotive Engineers)

Single grade	5W						
	10W						
	20W						
	#20						
	#30						
	#40						
Multigrade	10W-30						
	10W-40						
Ambient temperature	-20	-10	0	10	20	30	40°C
	-4	14	32	50	68	86	104°F

770081

Engine Maintenance: WM 130 / WM 170 / WM 270

The engine maintenance schedule(s) in this chapter are reproduced from the engine owner's manual. For additional information, see the engine owner's manual.

	Daily before starting	After first 20 hours	Every 2 weeks or 50 hrs.	Every month or 100 hrs.	Every year or 300 hrs.	Every 500 hrs.
Check fuel level.	■					
Check engine oil level.	■					
Inspect fuel lines.	■					
Inspect air filter. Replace as needed.	■					
Check external hardware.	■					
Clean air cleaner elements.			■			
Change engine oil.		■*		■		
Clean sediment cup / fuel filter.				■		
Check and clean spark plug.				■		
Check and adjust valve clearance.					■	
Replace spark plug.						■

* Perform initially after first 20 hours of operation.

Maintenance, replacement or repair of emission control devices and systems may be performed by any repair establishment or individual.

770082

Engine Maintenance: Honda GX160

7 Engine Maintenance: Honda GX160

The information in this chapter comes from copyrighted Honda material.

The viscosity of the engine oil is an important factor when determining the correct engine oil to use in your machine. Use an engine oil of appropriate viscosity based on the expected outside air temperature. See the table below.



WARNING

Most used liquids from this machine such as oil, gasoline, grease, etc., contain small amounts of materials that can cause cancer and other health problems if inhaled, ingested, or left in contact with skin for prolonged periods of time.

- ▶ Take steps to avoid inhaling or ingesting used liquids.
- ▶ Wash skin thoroughly after exposure to used liquids.

Recommended Oil

Use 4-stroke motor oil that meets or exceeds the requirements for API service category SJ or later (or equivalent). Always check the API service label on the oil container to be sure it includes the letters SJ or later (or equivalent).

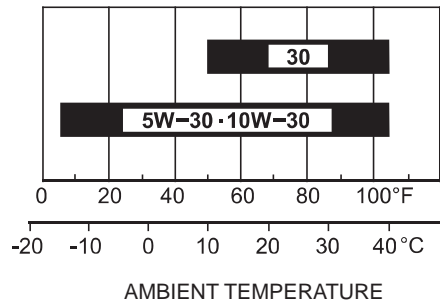

SAE 10W-30 is recommended for general use. Other viscosities shown in the chart may be used when the average temperature in your area is within the indicated range.

770077

Engine Maintenance: Honda GX160

The engine maintenance schedule(s) in this chapter are reproduced from the engine owner's manual. For additional information, see the engine owner's manual.

MAINTENANCE SCHEDULE

REGULAR SERVICE PERIOD (3) Perform at every indicated month or operating hour interval, whichever comes first.		Each Use	First Month or 20 Hrs	Every 3 Months or 50 Hrs	Every 6 Months or 100 Hrs	Every Year or 300 Hrs	Refer to Page
ITEM							
Engine oil	Check level	○					9
	Change		○		○		9
Reduction case oil (applicable types)	Check level	○					9-10
	Change		○		○		10
Air cleaner	Check	○					10
	Clean			○ (1)	○*(1)		11-12
	Replace					○**	
Sediment cup	Clean				○		12
Spark plug	Check-adjust				○		12
	Replace					○	
Spark arrester (applicable types)	Clean				○ (4)		13
Idle speed	Check-adjust					○ (2)	13
Valve clearance	Check-adjust					○ (2)	Shop manual
Combustion chamber	Clean	After every 500 Hrs. (2)					Shop manual
Fuel tank & filter	Clean				○ (2)		Shop manual
Fuel tube	Check	Every 2 years (Replace if necessary) (2)					Shop manual

- * • Internal vent carburetor with dual element type only.
Cyclone type every 6 months or 150 hours.

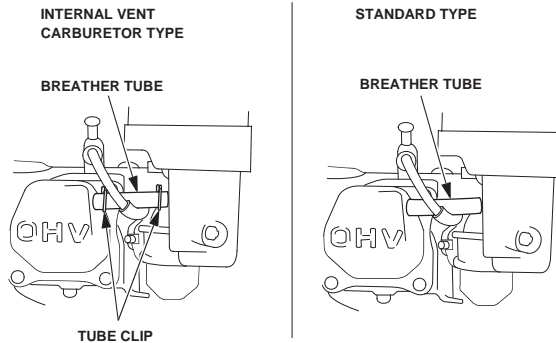

- ** • Replace paper element type only.
• Cyclone type every 2 years or 600 hours.

- (1) Service more frequently when used in dusty areas.
- (2) These items should be serviced by your servicing dealer, unless you have the proper tools and are mechanically proficient. Refer to the Honda shop manual for service procedures.
- (3) For commercial use, log hours of operation to determine proper maintenance intervals.
- (4) In Europe and other countries where the machinery directive 2006/42/EC is enforced, this cleaning should be done by your servicing dealer.

Failure to follow this maintenance schedule could result in non-warrantable failures.

770078

Engine Maintenance: Honda GX390

8 Engine Maintenance: Honda GX390

The information in this chapter comes from copyrighted Honda material.

The viscosity of the engine oil is an important factor when determining the correct engine oil to use in your machine. Use an engine oil of appropriate viscosity based on the expected outside air temperature. See the table below.



WARNING

Most used liquids from this machine such as oil, gasoline, grease, etc., contain small amounts of materials that can cause cancer and other health problems if inhaled, ingested, or left in contact with skin for prolonged periods of time.

- ▶ Take steps to avoid inhaling or ingesting used liquids.
- ▶ Wash skin thoroughly after exposure to used liquids.

Recommended Oil

Use 4-stroke motor oil that meets or exceeds the requirements for API service category SJ or later (or equivalent). Always check the API service label on the oil container to be sure it includes the letters SJ or later (or equivalent).

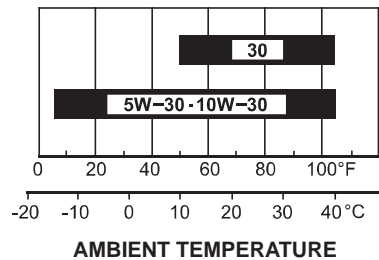

SAE 10W-30 is recommended for general use. Other viscosities shown in the chart may be used when the average temperature in your area is within the indicated range.

770079

Engine Maintenance: Honda GX390

The engine maintenance schedule(s) in this chapter are reproduced from the engine owner's manual. For additional information, see the engine owner's manual.

MAINTENANCE SCHEDULE

REGULAR SERVICE PERIOD (3) Perform at every indicated month or operating hour interval, whichever comes first.		Each Use	First Month or 20 Hrs	Every 3 Months or 50 Hrs	Every 6 Months or 100 Hrs	Every Year or 300 Hrs	Refer to Page	
ITEM								
Engine oil	Check level	○					9	
	Change		○		○		9	
Reduction case oil (applicable types)	Check level	○					9-10	
	Change		○		○		10	
Air cleaner	Check	○					10	
	Clean			○ (1)	○ *(1)		11-12	
	Replace					○ **		
Sediment cup	Clean				○		12	
Spark plug	Check-adjust				○		12	
	Replace					○		
Spark arrester (applicable types)	Clean				○ (4)		13	
Idle speed	Check-adjust					○ (2)	13	
Valve clearance	Check-adjust					○ (2)	Shop manual	
Combustion chamber	Clean	After every 1000 Hrs. (2)						Shop manual
Fuel tank & filter	Clean				○ (2)		Shop manual	
Fuel tube	Check	Every 2 years (Replace if necessary) (2)						Shop manual

- * • Internal vent carburetor with dual element type only.
Cyclone type every 6 months or 150 hours.

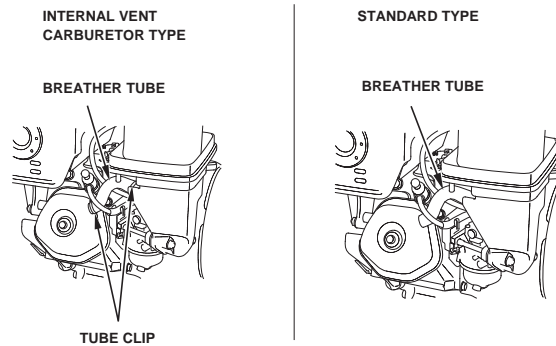

- ** • Replace paper element type only.
• Cyclone type every 2 years or 600 hours.

- (1) Service more frequently when used in dusty areas.
- (2) These items should be serviced by your servicing dealer, unless you have the proper tools and are mechanically proficient. Refer to the Honda shop manual for service procedures.
- (3) For commercial use, log hours of operation to determine proper maintenance intervals.
- (4) In Europe and other countries where the machinery directive 2006/42/EC is enforced, this cleaning should be done by your servicing dealer.

Failure to follow this maintenance schedule could result in non-warrantable failures.

770080

Engine Maintenance: Hatz 1B 20 / 1B 30

9 Engine Maintenance: Hatz 1B 20 / 1B 30

The information in this chapter comes from copyrighted Hatz material.

The viscosity of the engine oil is an important factor when determining the correct engine oil to use in your machine. Use an engine oil of appropriate viscosity based on the expected outside air temperature. See the table below.



WARNING

Most used liquids from this machine such as oil, gasoline, grease, etc., contain small amounts of materials that can cause cancer and other health problems if inhaled, ingested, or left in contact with skin for prolonged periods of time.

- ▶ Take steps to avoid inhaling or ingesting used liquids.
- ▶ Wash skin thoroughly after exposure to used liquids.

Oil viscosity

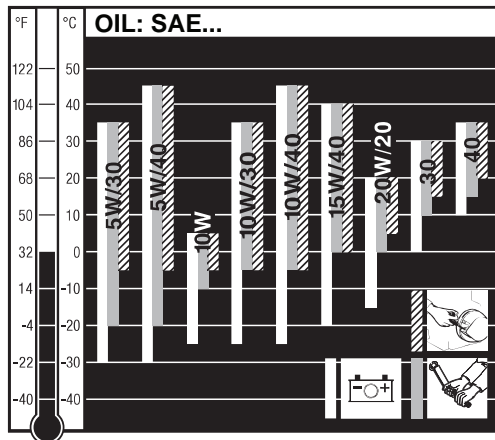

Choose the recommended viscosity based on the type of start (recoil, crank-handle or electric) and on the engine temperature at which the engine will be operated.

CAUTION



Engine damage from unsuitable engine oil.

Using engine oil that does not meet the above specifications considerably shortens the engine service life.

770062

Engine Maintenance: Hatz 1B 20 / 1B 30

The engine maintenance schedule(s) in this chapter are reproduced from the engine owner's manual. For additional information, see the engine owner's manual.

Symbol	Maintenance interval	Maintenance activity/check
	Every 8-15 operating hours or every day before starting	Check the oil level.
		Check the engine oil level in the bottom section of the oil bath filter and examine the oil for contamination. Change the oil if it is sludgy.
		In models with a cyclone pre-cleaner: remove the dust trap.
		Check the intake area of the combustion and cooling air.
		Check the air filter maintenance indicator.
		Check the water separator.
	Every 250 operating hours	Maintain the oil bath filter.
		Change the engine oil.
		Check and adjust the tappet clearance (not in models with an automatic valve lash adjustment).
		Clean the cooling air area.
		Check the screw connections.
		Clean the exhaust screen.

770063

Engine Maintenance: Hatz 1B 20 / 1B 30

Symbol	Maintenance interval	Maintenance activity/check	Chapter
9441	Every 500 operating hours	Change the fuel filter.	8.2.11 <i>Changing the fuel filter, page 68</i>
		Maintain the dry air filter.	8.2.12 <i>Maintaining the dry air filter, page 73</i>
1000h	Every 1000 operating hours	Clean the oil filter.	8.2.5 <i>Clean the oil filter, page 54</i>

In new and generally overhauled engines, after 25 operating hours:

- Change the engine oil
- Check the tappet clearance and adjust if necessary
- Check the screw connections (do not retighten the screws for attaching the cylinder head)

In case of a low number of operating hours, change the engine oil no later than every 12 months, regardless of the actual number of operating hours.

770064

10 Troubleshooting

Problem / Symptom	Reason	Remedy
Engine does not start.	<ul style="list-style-type: none"> ■ No fuel in tank ■ Old fuel ■ Engine oil pressure/oil level low ■ Impeller rubbing on insert 	<ul style="list-style-type: none"> ■ Add fuel. ■ Drain fuel tank, change fuel filter, and fill with fresh fuel. ■ Add engine oil. ■ Inspect impeller and remove shims as necessary.
Engine is hard to start.	<ul style="list-style-type: none"> ■ Dirt or debris inside pump housing blocking movement of impeller 	<ul style="list-style-type: none"> ■ Clean or remove debris.
Impeller does not turn and pump is hard to start.	<ul style="list-style-type: none"> ■ Impeller jammed or blocked ■ Impeller rubbing on insert 	<ul style="list-style-type: none"> ■ Remove pump housing cover and clean or remove debris. ■ Inspect impeller and remove shims as necessary.
Engine starts but pump does not take in water.	<ul style="list-style-type: none"> ■ Pump housing not filled with water ■ Suction strainer partially clogged ■ Suction hose damaged ■ Air leak at suction port ■ Pump too high above water line ■ Engine speed too low ■ Debris collecting in pump housing ■ Too much clearance between impeller and insert. 	<ul style="list-style-type: none"> ■ Prime the pump. ■ Clean or remove debris. ■ Repair or replace suction hose. ■ Repair air leak. ■ Move pump closer to water. ■ Run pump at maximum operating speed. ■ Clean or remove debris. ■ Inspect impeller and add shims as necessary.
Pump takes in water but discharges little or no water.	<ul style="list-style-type: none"> ■ Impeller worn ■ Discharge hose kinked or blocked ■ Engine speed too low ■ Volute insert worn or damaged 	<ul style="list-style-type: none"> ■ Inspect impeller and add shims as necessary. ■ Un-kink discharge hose or remove obstruction. ■ Run pump at maximum operating speed. ■ Adjust clearance or replace volute insert.
Suction hose leaks at inlet.	<ul style="list-style-type: none"> ■ Clamps not sealed properly ■ Suction hose diameter too large ■ Suction hose damaged 	<ul style="list-style-type: none"> ■ Tighten, replace, or add clamps. ■ Use a hose with a smaller diameter. ■ Replace suction hose.
Discharge hose does not stay on coupling.	<ul style="list-style-type: none"> ■ Pressure is too high for clamps being used ■ Discharge hose kinked or blocked 	<ul style="list-style-type: none"> ■ Add another clamp. ■ Un-kink discharge hose or remove obstruction.
Engine stops by itself.	<ul style="list-style-type: none"> ■ No fuel in tank ■ Engine oil pressure/oil level low ■ Engine too hot 	<ul style="list-style-type: none"> ■ Add fuel. ■ Add engine oil. ■ Allow the engine to cool. Check/add coolant.

11 Technical Data

11.1 Engine—PT2 / PT2(I) / PT2H / PT2H(I)

Machine		PT2 5000009318	PT2H 5000009094 5000009097
Engine type		4-stroke, overhead valve, single cylinder	4-stroke, air cooled, diesel
Engine make		Wacker Neuson	Hatz
Engine model		WM170	1B 20
Maximum rated power at rated speed ¹	kW (hp)	4.2 (5.7) @ 4000 rpm	3.4 (4.6) @ 3600 rpm
Displacement	cm ³ (in. ³)	169 (10.3)	232 (14.2)
Spark plug		(NGK) BR 6HS Champion RL86C	—
Electrode gap	mm (in.)	0.6–0.7 (0.024–0.028)	—
Operating speed	rpm	3500	
Maximum engine speed—no load	rpm	3700 ± 100	3700 ± 50
Valve clearance (cold)	mm (in.)	Intake and exhaust: 0.12–0.15 (0.005–0.006)	
Air cleaner	type	Dual element	Dry pleated paper element
Engine lubrication	oil grade	SAE 10W30 Service class SJ, SL	CH, CI, CJ rated
Engine oil capacity	L (qt)	0.60 (0.63)	0.90 (.95)
Fuel	type	Regular unleaded gasoline	No. 2 diesel
Fuel tank capacity	L (qt)	3.6 (3.8)	3.0 (3.2)

¹Net engine power rating per SAE J1349 and ISO 3046. Actual power output may vary due to conditions of specific use.

11.2 Engine—PT2A / PT2A(I)

Machine		PT2A 5000009092 (100–200) 5000009095 (100–201) 5000009237 (100–201)	PT2A 5000009092 (201–) 5000009095 (202–) 5000009237 (202–)
Engine type		4-stroke, overhead valve, single cylinder	
Engine make		Honda	
Engine model		GX 160 K1 TX2	GX 160 UT2 TX2
Maximum rated power at rated speed ¹	kW (hp)	3.6 (4.8) @ 3600 rpm	
Displacement	cm ³ (in. ³)	163 (9.9)	
Spark plug		(NGK) BPR 6ES BOSCH WR7DC	
Electrode gap	mm (in.)	0.7–0.8 (0.028–0.031)	
Operating speed	rpm	3500	
Maximum engine speed—no load	rpm	3700 ± 100	
Valve clearance (cold) intake: exhaust:	mm (in.)	0.15 ± 0.02 (.006) 0.20 ± 0.02 (.008)	
Air cleaner	type	Dual element	
Engine lubrication	oil grade	SAE 10W30 Service Class SJ, SL	
Engine oil capacity	L (qt)	0.6 (0.63)	
Fuel	type	Regular unleaded gasoline	
Fuel tank capacity	L (qt)	3.1 (3.3)	

¹Net engine power rating per SAE J1349 and ISO 3046. Actual power output may vary due to conditions of specific use.

11.3 Engine—PT3 / PT3A / PT3(I) / PT3H

Machine		PT3 5000009321 5000009322	PT3A 5000009098 5000009101 5000009240 5000620800	PT3H 5000009100 5000009103
Engine type		4-stroke, overhead valve, single cylinder		4-stroke, air cooled, diesel engine
Engine make		Wacker Neuson	Honda	Hatz
Engine model		WM270	GX240 UT2PA2	1B 30
Maximum rated power at rated speed ¹	kW (hp)	6.6 (9) @ 4000 rpm	5.9 (7.9) @ 3600 rpm	5.0 (6.8) @ 3600 rpm
Displacement	cm ³ (in. ³)	265 (16.17)	270 (16.5)	347 (21.2)
Spark plug		(NGK) BR 6HS Champion RL86C	(NGK) BPR 6ES (DENSO) W20EPR-U	—
Electrode gap	mm (in.)	0.6–0.7 (0.024–0.028)	0.7–0.8 (0.028–0.031)	—
Operating speed	rpm	3500		
Maximum engine speed—no load	rpm	3700 ± 100		3700 ± 50
Valve clearance (cold) Intake and exhaust	mm (in.)	—		0.10 (0.004)
Air cleaner	type	Dual element		Dry pleated paper element
Engine lubrication	oil grade	SAE 10W30 Service class SJ		CD, CE, CF, CG rated
Engine oil capacity	L (qt)	1.1 (1.2)		
Fuel	type	Regular unleaded gasoline		No. 2 diesel
Fuel tank capacity	L (qt)	6.0 (6.4)	5.3 (5.6)	5.0 (5.3)

¹Net engine power rating per SAE J1349 and ISO 3046. Actual power output may vary due to conditions of specific use.

11.4 Pump—PT2 / PT2(I) / PT2A / PT2H

Machine		PT2(I) 5000620725	PT2 5000009318	PT2A 5000009092 5000009095 5000009237	PT2H 5000009094 5000009097
Dimensions	mm (in.)	550 x 465 x 500 (21.7 x 18.3 x 19.6)			590 x 495 x 510 (23.2 x 19.4 x 20.0)
Operating weight	kg (lb)	—	43 (96)		59 (131)
Maximum suction lift ¹	m (ft)	7.5 (25)			
Maximum total head	m (ft)	32 (106)			
Maximum pressure	bar (psi)	3.2 (46)			
Maximum flow rate ²	L/min (gpm)	652 (172)			
Suction / discharge diameter	mm (in.)	50 (2)			
Maximum solid size	mm (in.)	25 (1)			

¹Based on pump operating at sea level. Maximum suction lift will be less at higher altitudes.

²Zero net head

11.5 Pump—PT3 / PT3(I) / PT3A / PT3H

Machine		PT3(I) 5000620726	PT3 5000009321 5000009322 5000009323	PT3A 5000009098 5000009101 5000009240 5000620800	PT3H 5000009100 5000009103 5000009242
Dimensions	mm (in.)	675 x 505 x 570 (26 x 20 x 23)			
Operating weight	kg (lb)	—	64 (140)	68 (149)	77 (169)
Maximum suction lift ¹	m (ft)	7.5 (25)			
Maximum total head	m (ft)	29 (93)			
Maximum pressure	bar (psi)	2.8 (40)			
Maximum flow rate ²	L/min (gpm)	1350 (356)			
Suction / discharge diameter	mm (in.)	75 (3)			
Maximum solid size	mm (in.)	38 (1.5)			

¹Based on pump operating at sea level. Maximum suction lift will be less at higher altitudes.

²Zero net head

11.6 Sound Measurements

Products are tested for sound pressure level in accordance with EN ISO 11201:2010.

Sound power level is tested in accordance with European Directive 2000/14/EC - Noise Emission in the Environment by Equipment for use outdoors.

Machine	Sound Pressure at Operator's Location dB(A)	Guaranteed Sound Power dB(A)
PT2A	99	101
PT2H	102	103
PT3A	101	102
PT3H	106	106

11.7 Dimensions

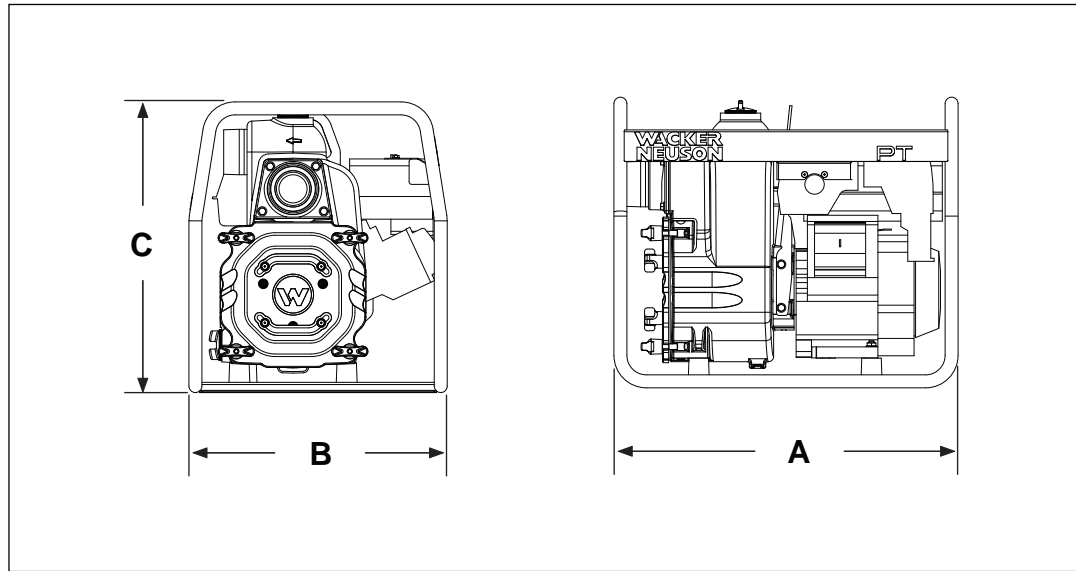

wc_gr012713

Machine		A	B	C
PT2	mm (in.)	550 (21.7)	465 (18.3)	500 (19.6)
PT2(l)				
PT2A				
PT2H				
PT3	mm (in.)	675 (26.0)	505 (20.0)	570 (23.0)
PT3(l)				
PT3A				
PT3H				



12 Emission Control Systems Information and Warranty

The Emission Control Warranty and associated information is valid only for the U.S.A., its territories, and Canada.

12.1 Emission Control Systems Warranty Statement

See the supplied engine owner's manual for the applicable exhaust and evaporative emission warranty statement.



PORTABLE PUMPS

www.aem.org



SAFETY MANUAL

FOR OPERATING AND MAINTENANCE PERSONNEL

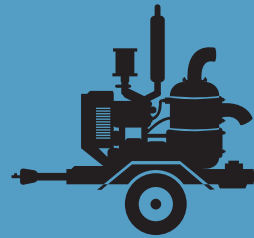
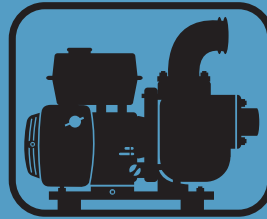

SAFETY ALERT SYMBOL



This Safety Alert Symbol means
ATTENTION is involved!

The Safety Alert Symbol identifies important safety messages on machines, safety signs, in manuals, or elsewhere. When you see this symbol, be alert to the possibility of personal injury or death. Follow the instructions in the safety message.

Why is SAFETY important to YOU?

3 BIG REASONS

- **Accidents KILL or DISABLE**
- **Accidents COST**
- **Accidents CAN BE AVOIDED**

NOTICE OF COPYRIGHT PROTECTION

AEM Safety Manuals are protected as a copyrighted work with ownership duly registered with the Copyright Office, Washington, D.C. Any reproduction, translation, decompiling or other use of an AEM Safety Manual, or portion thereof, or the

creation of derivative works based on an AEM Safety Manual, without the prior written approval of AEM is expressly prohibited. Copyright infringement can result in civil and criminal sanctions, damages and other penalties being imposed.

Copyright © 2004— Association of Equipment Manufacturers

1

REFERENCES

The following is a partial list of referenced material on safe operating practices:

U.S. Department of Labor publishes safety and health regulations and standards under the authority of the Occupational Safety and Health Act for the general construction and mining industries.

U.S. Department of Labor
Washington, DC 20210

NFPA — National Fire Protection Association
P.O. Box 9101
1 Battery March Park
Quincy, MA 02269-9101

SAE — Society of Automotive Engineers, Inc.
400 Commonwealth Drive
Warrendale, PA 15096
Publishes a list, "Operator Precautions" SAE J153
MAY 87.

AEM — Association of Equipment Manufacturers
111 East Wisconsin Avenue
Milwaukee, WI 53202

CONTENTS

	Page	Section
FOREWORD.....	4	
FOLLOW A SAFETY PROGRAM	5	1
PERFORM MAINTENANCE SAFELY	7	2
PREPARE FOR SAFE OPERATION	9	3
WORK SAFELY – Pumps In General	10	4
WORK SAFELY – Engine Driven Pumps.....	13	5
WORK SAFELY – Electric Motor Driven Pumps.....	15	6
WORK SAFELY – Submersibles	17	7
TEST YOUR KNOWLEDGE	19	8
FINAL WORD TO THE USER	20	9

FOREWORD

This safety manual is intended to point out some of the basic situations which may be encountered during the normal operation and maintenance of your equipment, and to suggest possible ways of dealing with these conditions.

Additional precautions may be necessary, depending on application, pump type, configuration and attachments used, conditions at the work-site or in the maintenance area. The manufacturer has no direct control over pump application, operation, inspection, lubrication or maintenance. Therefore, it is your responsibility to use good, safe, practices in these areas.

The information provided in this manual supplements the specific information about your pump that is contained in the manufacturer's manual(s). Other information which may affect the safe operation of your pump may be contained on safety signs, decals, markings, insurance requirements, employer's safety programs, safety codes, local, state/provincial and federal laws, rules and regulations, contracts, agreements and warranties.

It is your responsibility to read and understand this safety manual and the manufacturer's manual(s) before operating your pump. This safety manual takes you step-by-step through your working day. If you do not understand any of this information, or if errors or contradictions seem to exist, consult with your supervisor before operating your pump.

IMPORTANT: If you do not have the manufacturer's manual(s) for your particular pump, get a replacement manual from your employer, equipment dealer, or manufacturer of your pump. Keep this safety manual and the manufacturer's manual(s) with your pump.

Unauthorized modifications of pumps create hazards. Pumps must not be modified or altered unless prior approval is obtained from the manufacturer.

DO NOT PUMP VOLATILE/FLAMMABLE OR CAUSTIC/CORROSIVE LIQUIDS.

REFER TO THE OWNER'S MANUAL OR CONSULT WITH THE MANUFACTURER FOR THE PROPER PUMP MATERIALS IF YOU ARE TO PUMP HAZARDOUS CAUSTIC/CORROSIVE LIQUIDS.

FOLLOW A SAFETY PROGRAM

KNOW THE RULES

Every employer is concerned about safety. Safe operation and proper maintenance of your pump can prevent accidents. **KNOW** the rules — **LIVE** by them. (FIG. 1)

When starting work at a new site, check with the designated safety coordinator for specific safety instructions. **DON'T LEARN SAFETY THE HARD WAY.**

Know the meaning of all hand signals, signal flags, signs and markings.

Know the traffic rules used at the work site. Know who the signal man is; watch and obey his signals.

Know where the fire extinguishers and first aid kits are kept and how to use them. Know where to get proper aid and assistance when needed.

Use common sense to avoid accidents. If an accident does occur, be prepared to react to it quickly and effectively.

NEVER PANIC.

Remember that **YOU are the key to safety.** Good safety practices not only protect you but also protect the people around you. Study this manual and the manufacturer's manual(s) for your specific pump. Make them a working part of your safety program. Keep in mind that this safety manual is written for only this type of equipment. Practice all other usual and customary safe working precautions, and above all (FIG. 1).

**REMEMBER — SAFETY IS UP TO YOU
YOU CAN PREVENT
SERIOUS INJURY OR DEATH**



FIG. 1

1

5

FOLLOW A SAFETY PROGRAM

KNOW WHAT IT IS?

Consult your supervisor for specific instructions and personal safety equipment required.

For instance, you may need:

- Hard Hat
- Safety Shoes
- Eye Protection
- Respirators
- Heavy Gloves
- Reflector Vests
- Hearing Protection
- Face Protection
- Back Supports
- Other job related specific items

Do not wear loose clothing or any accessory — flopping cuffs, untied shoe-laces, dangling neckties and scarves, rings, wrist watches, or other jewelry — that can catch on protruding or moving parts or controls. Long hair should be securely bound to prevent entanglement with moving parts. (FIG. 3)



FIG. 2



FIG. 3

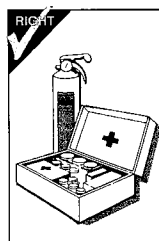

FIG. 4

BE ALERT!

Know where to get assistance. Know how to use a first aid kit and fire extinguisher or fire suppression system. (FIG. 4)

BE AWARE!

Take advantage of training programs offered.

Safety programs should require that one person at each jobsite be assigned the overall responsibility and authority for safety. Know who the person is, and **COMMUNICATE** with them.

Know what the jobsite rules are, and **FOLLOW THE RULES.** Be safety conscious, responsible and reliable. Think about safety **BEFORE** something happens.

BE CAREFUL!

Human error is caused by many factors: carelessness, fatigue, overload, preoccupation, incompatibility between operator and the equipment, drugs, and alcohol to name a few. Damage to the equipment can be fixed in a short period of time, but injury, or death has a lasting effect.

For your safety and safety of others, encourage your fellow workers to act within safety rules.

1

6

PERFORM MAINTENANCE SAFELY

CLOTHING AND PERSONAL PROTECTIVE ITEMS

ALWAYS wear appropriate safety glasses, goggles or face shield when working. (FIG. 2) Proper eye protection can keep flying particles from grinding, drilling or hammering operations, or fluids such as fuel, solvents, lubricants and brake fluids from damaging your eyes. Normal glasses do NOT provide adequate protection.

ALWAYS wear a hard hat and safety shoes. (FIG. 2) ALWAYS wear hearing protectors when exposed to high noise levels for extended periods. ALWAYS wear a respirator when painting or exposed to dusty conditions. ALWAYS keep your pockets free of loose objects which can fall out and drop into machinery. (FIG. 5) Heavy gloves should be worn for many operations.

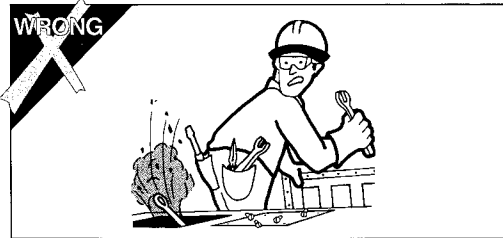

FIG. 5

EXHAUST FUMES

Engine exhaust fumes can cause sickness or death. If it is necessary to run an engine in an enclosed area, remove the exhaust fumes from the area with an exhaust pipe extension. If you do not have an exhaust pipe extension, be positive the area is adequately ventilated. (FIG. 6)



FIG. 6

HEAVY PARTS

Handle tools and heavy parts sensibly — with regard for yourself and other persons. Lower items — don't throw or drop them.

ALWAYS use proper hoisting equipment for lifting heavy loads.

ALWAYS use a back brace when lifting by hand.

2

7

PERFORM MAINTENANCE SAFELY

FIRE PREVENTION

Whenever possible use a nonflammable solvent to clean parts. Do not use gasoline or other fluids that give off harmful vapors.

If flammable fluids, such as gasoline or diesel fuel, must be used, extinguish open flames or sparks and DO NOT smoke.

Store dangerous fluids in a suitable place, in approved containers which are clearly marked. NEVER smoke in areas where flammable fluids are used or stored. (FIG. 7)

Use proper nonflammable cleaning solvents. Follow solvent manufacturer's instructions for use.

Always remove all flammable material in the vicinity of welding and/or burning operations.

ALWAYS keep the floor in the work area clean and dry. Oily, greasy floors can easily lead to falls. Wet spots, especially near electrical equipment, can be hazardous. (FIG. 7)

Know where fire extinguishers are kept — how they operate — and for what type of fire they are intended.

Check readiness of any fire detectors and fire suppression systems.



FIG. 7

2

8

PREPARE FOR SAFE OPERATION

LEARN TO BE SAFE

NEVER operate a pump which is new to you without first being instructed in its proper operation. READ the operator's manual. If one has not been provided, GET ONE AND STUDY IT BEFORE OPERATING THE PUMP.

Know the meaning of all identification symbols on your controls and gauges. (FIG. 8)

Know the location of the emergency shut-down control if the machine is so equipped.

Before attempting to operate the pump, know the capabilities and limitations of the pump. Familiarize yourself with controls and instruments — their locations and functions.

Keep hands, levers and knobs clean of oil or grease to prevent slipping.

Carefully read and follow the instructions on all safety signs and decals on the pump. Keep safety signs in good condition. Replace missing or damaged safety signs.

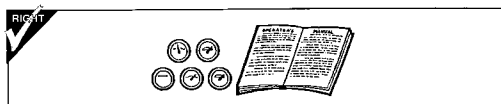

FIG. 8

CHECK IT OUT!

Know what safety devices your machine is equipped with ... and see that each item is securely in place and in operating condition. (FIG. 9)

For example:

- Drawbar Coupling Chains and Pins
- Alarms and Warning Lamps
- Reflectors
- Guards and Shields
- Drain Covers, Plugs, and Caps
- Shut-Down Devices
- Leveling Jacks
- Pressure Relief Devices
- Lifting Devices



FIG. 9

NEVER START OR OPERATE A PUMP KNOWN OR SUSPECTED TO BE DEFECTIVE OR MALFUNCTIONING.

If your daily check uncovers any items that need attention — repair, replacement, or adjustment — report them promptly. The most minor malfunction could be the result of more serious trouble — or can cause it, if pump is operated. When in doubt, attach an OSHA Lockout/Tagout device tag to the control panel to disconnected electrical power supply at breaker, on electrically driven pumps and disconnect the battery and/or spark plug wire on engine driven pumps.

3

9

WORK SAFELY — Pumps In General

SAFE WORKING PROCEDURES

USE COMMON SENSE! Most accidents can be avoided by using common sense and concentrating on the job to be done.

ONLY EXPERIENCED AND QUALIFIED personnel should install and operate pump equipment.

KNOW THE PROPER starting procedure for your equipment. Follow the manufacturer's operation manual ... to the letter.

DO NOT operate a pump without all guards and shields in place. (If OSHA required guards are damaged or misplaced, contact the manufacturer for a replacement.)

When **lifting pump** use only lifting equipment in good repair and with adequate capacity. Follow manufacturer's lifting recommendation.

Check all lubricant levels before pump installation in accordance with manufacturer's maintenance programs.

Keep hands and feet clear of moving parts. DO NOT stick fingers into a pump when in operation. Check suction strainer and hose regularly for proper submergence and to be sure it is free of obstructions.

NEVER operate a self-priming pump unless the volute is filled with liquid. The pump will not prime when dry.

PUMP only liquids for which the pump has been designed to handle.

DO NOT pump flammable, corrosive or caustic materials unless the pump and piping are explicitly designed for that purpose.

NOTE the direction of rotation — operation of a pump in the wrong direction can cause the impeller to unscrew and damage the volute case.

A pump should not be operated against a closed valve or other no flow conditions. Refer to the pump manufacturer's recommended practice for start-up, operation and shut-down procedures. **DO NOT** close down or restrict a discharge hose. **Be careful** of discharge hose whipping under pressure.

4

WORK SAFELY – Pumps In General

MAKE CERTAIN that whatever is to be connected to the pump is not subjected to pressures greater than those given in the manufacturer's instructions.

MAKE CERTAIN all connections are securely made and hoses under pressure are secured, with appropriate safety devices, to prevent whipping.

BE AWARE OF LIGHTNING. Stay clear of the pumping equipment during electrical storms. It can attract lightning. (FIG. 10)

OVERHEATING PRECAUTIONS

Overheated pumps can cause severe damage to the equipment and can cause severe physical burns and injury.

Operating a pump with the suction and/or discharge valve closed is a principal cause of overheating. Approach cautiously any pump that has been in operation.

DO NOT remove hoses from a pump until the system is properly cooled to ambient temperature.

DO NOT remove the cover plate or drain plugs from any overheated pump. Allow the pump to cool. Check pump temperature before opening fill port or drain plug.

If overheating of the pump casing occurs:

- **STOP** the pump immediately.
- Allow the equipment to **cool completely**.
- Slowly and cautiously **vent the pump**.
- **Refer to the manufacturer's instruction manual** before restarting the unit.
- Remove hoses carefully. Heated water can be in hoses and static head produces pressure.

4

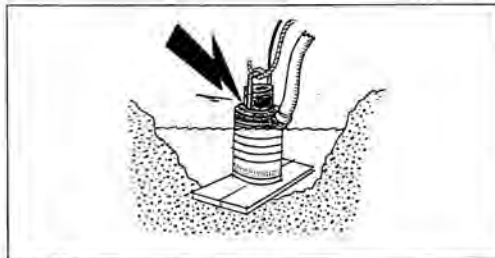

FIG. 10

11

WORK SAFELY – Pumps In General

BEFORE STARTING

Check the pump thoroughly at delivery for any shipping damage.

Locate the pump in an accessible location, as close to the liquid as possible.

Secure the pump after it is placed in its intended operating position so it does not tip, roll, slide or fall.

IMMEDIATELY ON STARTING THE PUMP

Observe gauges, instruments and warning lights to ensure that they are functioning and their readings are within the normal operating range.

- Be sure the immediate work area is safe for operation.
- Operate controls; make certain all operate properly and "feel" right. Accustom yourself to the "feel" of the equipment.
- Listen for any unusual noises, smell for any unusual odors; look for any signs of trouble.
- Be sure to open all manual valves slowly to prevent WATER HAMMER.
- Check all warning and safety devices and indicators.

• If safety-related defects or malfunctions are detected, **SHUT DOWN** the equipment. Correct the problem, or notify your supervisor. **DO NOT OPERATE EQUIPMENT WITH DEFECTS OR MALFUNCTIONS UNTIL CORRECTED.**

• **If an unsafe condition cannot be remedied immediately, notify your supervisor and tagout/lockout** the pump on the start switch and/or appropriate, prominent location. (FIG. 11)

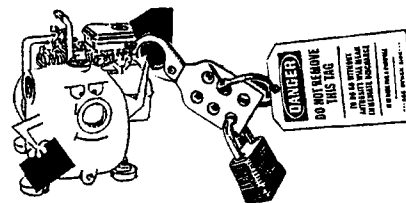

FIG. 11

4

WORK SAFELY – Engine Driven Pumps

SAFE WORKING PROCEDURES

Do not jump start engine battery.

When operating internal combustion engines in an enclosed area, always make provisions to pipe exhaust fumes to the outside.

EXHAUST FUMES CAN KILL: Do not operate engine driven pump equipment in a confined or enclosed space without adequate ventilation.

Exhaust gases are odorless and deadly poison.

DO NOT TOUCH: The exhaust system components get very hot and stay hot for some time after shutting the engine off.

Follow engine manufacturer's instructions explicitly on hand cranking.

Do not shut down high head pumps quickly:

- A) Throttle back slowly
- B) Open by-pass line
- C) Should have a check valve
- D) Slowly close gate valve on discharge if so equipped.

Check for fuel, oil and hydraulic fluid leaks, worn and damaged hoses/lines or power cables.

Refueling

When refueling, the following precautions must be followed:

- Add fuel of proper type and grade, only when the pump is not running and engine is cool.
- Fuel in well ventilated area.
- Turn off all electrical switches.
- Keep lighted smoking materials, flames or spark producing devices at a safe distance while refueling.
- Keep fuel nozzle in contact with tank being filled, or provide a ground to prevent static sparks from igniting fuel.
- **Do not spill fuel on hot surfaces.**
- Clean up spillage immediately.
- Do not start engine until fuel cap is secured to the fuel tank.
- **Always** make sure that fuel is being put in the fuel tank, motor oil in the proper location and hydraulic oil into hydraulic oil reservoirs.

5

13

WORK SAFELY – Engine Driven Pumps

Maintenance and Repair

All installations, operations and maintenance should be in accordance with pump and engine manufacturer's recommended operation and maintenance program. These manuals should be kept available with the equipment.

Maintenance work can be **hazardous** if not done in a careful manner. All personnel should realize the hazards and strictly follow safe practices.

NEVER perform any work on the equipment unless authorized to do so.

BEFORE ANY maintenance **work** is to be done, a LOCKOUT/TAGOUT standard device and procedure should be implemented. Prior to removal of LOCKOUT/TAGOUT, the equipment must be fully operational and all personnel accounted for. Except in cases of emergency, the removal of the LOCKOUT/TAGOUT should be done **ONLY** by the initiating person prior to the return to start-up (see page 12, Fig. 11).

BEFORE doing any major work, disconnect the ignition and battery if so equipped.

Always replace safety devices removed during service or repair before returning pump to operation.

Battery Servicing

- **Always wear** safety glasses and gloves when servicing or working with batteries.
- **Before servicing battery**, turn off electrical systems, then disconnect ground terminal clamp. Before installing a battery, turn off electrical equipment, then connect the battery ground clamp **last**.
- **Maintain** electrolyte at the recommended level. Check level frequently. Add distilled water to batteries only when starting up, never when shutting down.
- **Use a flashlight** to check level. **NEVER** use a flame.
- **Do not short** across battery terminals — the spark could ignite the battery gases.

Battery acids will **burn skin**, eat holes in clothing, and can **cause blindness** if splashed in eyes.

If you spill acid on yourself flush skin immediately with lots of water. Apply baking soda to help neutralize the acid. If acid gets into the eyes, flush immediately with large amounts of water and seek proper medical treatment immediately.

5

14

WORK SAFELY – Electric Motor Driven Pumps

SAFE WORKING PROCEDURES

Allow only qualified personnel to INSTALL, WIRE AND OPERATE electric motor driven pumps. Whenever electricity is present there is the possibility of **electrocution**.

NEVER use a pump/motor in an explosive atmosphere if it is not exclusively designed for the application.

Always ground electrical units.

Make certain to connect pump motor to the right phase and voltage.

Do not run pump if voltage is not within limits.

Make sure motor rotation is in accordance with impeller rotation (which should be indicated somewhere on the pump — check the manufacturer's manual).

Make all electrical installations in accordance with National Electric Code, State and Local electrical codes.

Never use gas piping as an electrical ground.

Make sure the related electrical circuits are dead and locked out before performing any maintenance.

Follow motor manufacturer's recommended maintenance and operation instructions.

If circuit breaker or fuse is tripped, examine the system for the problem before restarting pump.

NEVER use the power cord to aid lifting the pump.

NEVER operate a pump with a plug-in type power cord without a ground fault circuit interrupter.

NEVER use cords with frayed, cut or brittle insulation. Check the cord on the pump for nicks in the insulation and for sound connections to the ground fault interrupter plug and motor.

NEVER let extension cords or the plug connections lay in water. Locate the pump so that the cord cannot fall into any water or be submerged by rising water, unless the pump is designed for such use.

NEVER handle energized power cords with wet hands.

MOTOR OVERLOAD: do not exceed the manufacturer's recommendation for maximum lift or discharge head. See manufacturer's published curve for proper sizing of motors. A misapplied motor can overheat.

6

15

WORK SAFELY – Electric Motor Driven Pumps

Pump Maintenance and Repair

MAKE SURE the pump is disconnected from the power source or the appropriate circuits are dead and OSHA Lockout/Tagout is applied before doing any maintenance or repair work on the pump.

Maintenance work can be **hazardous** if not done in a careful manner. All personnel should realize the hazards and strictly follow safe practices.

NEVER perform any work on the equipment unless authorized to do so. (FIG. 11) Before performing any maintenance or repair work, consult the manufacturer's instruction manual for recommended procedures.

Pumps with float switches or other automatic devices can start without warning if not properly locked out.

BEFORE ANY maintenance work is to be done, a LOCKOUT/TAGOUT standard device and procedure should be implemented. Prior to removal of LOCKOUT/TAGOUT, the equipment must be fully operational and all personnel accounted for. Except in cases of emergency, the removal of the LOCKOUT/TAGOUT should be done **ONLY** by the initiating person prior to the return to start-up.

ALWAYS replace safety devices removed during the service or repair before returning pump to operation.

NEVER use the power cord to aid in lifting the pump.

Sizing Extension Cords

Use the following chart to select the correct size extension cord to prevent excessive amperage draw or voltage drop which would cause the motor to overheat. **Cables that are too long or coiled** can cause a voltage drop. **Be aware** that strong sunlight can cause a voltage drop.

Amperes	Wire Gauge and Cord Length (in feet)		
	50	100	150
6	16	16	14
8	16	14	12
10	16	14	12
12	14	14	12
14	14	12	10
16	12	12	10

6

WORK SAFELY – Submersibles

SAFE WORKING PROCEDURES

ALLOW only qualified personnel to INSTALL, WIRE and OPERATE submersible pumps.

Whenever electricity is present there is the possibility of **electrocution**.

NEVER use a pump/motor in an explosive atmosphere, if it is not exclusively designed for that application.

ALWAYS ground the pump.

Make certain to connect the pump to the right phase and voltage.

DO NOT run the pump if voltage is not within limits. **Make all electrical installations** in accordance with National Electric Code, State and Local electrical codes.

Mount electrical control box in a vertical position, protected from the elements.

NEVER attempt to use the power cord or hydraulic hoses as a lifting or lowering device for submersibles. Attach a lifting cable to the manufacturer's recommended attachment point on the pump for lowering and lifting the pump. (FIG. 12)

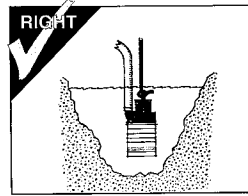

FIG. 12

NEVER position the pump directly on a soft, loose bottom. To attain maximum capacity and prevent excessive wear, position the pump so it will not burrow itself into sand or clay. Stand the pump on a plank, a bed of coarse gravel, within a perforated container, on a suitable floatation device, or retain it hanging freely by a lifting cable. (FIG. 13)

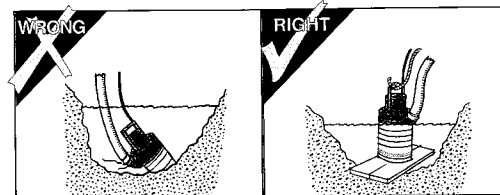

FIG. 13

7

17

WORK SAFELY – Submersibles

Pump Maintenance and Repair

MAKE SURE the pump is disconnected from the power source or the appropriate circuits are dead and OSHA Lockout/Tagout is applied before doing any maintenance or repair work on the unit.

Maintenance work can be **hazardous** if not done in a careful manner. All personnel should realize the hazards and strictly follow safe practices.

NEVER perform any work on the equipment unless authorized to do so. Before performing any maintenance or repair work, consult the manufacturer's instruction manual for recommended procedures.

BEFORE ANY maintenance work is to be done, a LOCKOUT/TAGOUT standard device and procedure should be implemented. Prior to removal of LOCKOUT/TAGOUT, the equipment must be fully operational and all personnel accounted for. Except in cases of emergency, the removal of the LOCKOUT/TAGOUT should be done **ONLY** by the initiating person prior to the return to start-up.

Check oil level ONLY when pump is cool.

USE ONLY recommended oil per manufacturer's recommendation.

INSPECT ELECTRICAL WIRING for worn or damaged insulation. **INSTALL** new wiring if wires are damaged. **After repairs are made, clean the equipment before putting the pump back into position.**



7

TEST YOUR KNOWLEDGE

Do you understand this AEM SAFETY MANUAL AND ITEMS SUCH AS ...

- Your safety program?
 - Your pump manufacturer's manual(s)?
 - Proper clothing and personal safety equipment?
 - Your pump's controls, warning signs and devices, and safety equipment?
 - How to properly inspect, mount, and start your pump?
 - How to check your pump for proper operation?
 - Your work area and any special hazards that may exist?
- Proper operating procedures?
 - Proper shutdown procedures?
 - Proper maintenance procedures?
 - Proper loading and unloading procedures for transporting?
 - Under what conditions you should not operate your pump?

If you do not understand any of these items, consult with your supervisor BEFORE operating your equipment!

8

19

FINAL WORD TO THE USER

Remember that **YOU are the key to safety**. Good safety practices not only protect you but protect the people around you.

You have read this safety manual and the manufacturer's manual(s) for your specific pump. Make them a working part of your safety program. Keep in mind that this safety manual is written for only this type of equipment.

Practice all other usual and customary safe working precautions, and above all —

**REMEMBER
SAFETY IS UP TO YOU
YOU CAN PREVENT SERIOUS
INJURY OR DEATH**

9

20

This manual is another in a series on the safe operation of machinery published by AEM.
For additional publications visit our web site at www.aem.org.



Association of Equipment Manufacturers

Toll free 1-866-AEM-0442

e-mail aem@aem.org

www.aem.org

Important: For spare parts information, please see your Wacker Neuson Dealer, or visit the Wacker Neuson website at <http://www.wackerneuson.com/>.

Wichtig! Informationen über Ersatzteile erhalten Sie von Ihrem Wacker Neuson Händler oder besuchen Sie die Wacker Neuson Website unter <http://www.wackerneuson.com/>.

Important : Pour des informations sur les pièces détachées, merci de consulter votre distributeur Wacker Neuson, ou de visiter le site Internet de Wacker Neuson sur <http://www.wackerneuson.com/>.

Importante : Para saber más sobre las piezas de repuesto, póngase en contacto con su distribuidor de Wacker Neuson o acceda al sitio web de Wacker Neuson en <http://www.wackerneuson.com/>.

Importante : Per informazioni sui pezzi di ricambio, contattare il rivenditore Wacker Neuson o visitare il sito di Wacker Neuson all'indirizzo www.wackerneuson.com.

Viktigt : För information om reservdelar, kontakta din Wacker Neuson-leverantör eller besök Wacker Neusons webbplats på <http://www.wackerneuson.com/>.

Tärkeää : Pyydä varaosatietoja Wacker Neusonin jälleenmyyjältä tai vieraile Wacker Neusonin web-sivustolla osoitteessa <http://www.wackerneuson.com/>

Viktig : For informasjon om reservedeler, vennligst kontakt din Wacker Neuson-forhandler, eller besøk Wacker Neusons nettside på <http://www.wackerneuson.com/>.

Viktigt : Hvis du ønsker oplysninger om reservedele, bedes du kontakte din Wacker Neuson forhandler eller besøg Wacker Neuson websiden på <http://www.wackerneuson.com/>.

Belangrijk! Neem contact op met uw Wacker Neuson dealer of bezoek de website van Wacker Neuson op <http://www.wackerneuson.com/> voor meer informatie over reserveonderdelen.

Importante : Para obter informações sobre as peças sobresselentes, consulte o seu fornecedor da Wacker Neuson ou acesse ao site Web da Wacker Neuson em http://www.wackerneuson.com

Ważne : W celu uzyskania informacji na temat części zamiennych skontaktuj się z przedstawicielem firmy Wacker Neuson lub skorzystaj z witryny internetowej <http://www.wackerneuson.com/>.

Důležitě upozornění! Pro informace o náhradních dílech, prosím, kontaktujte svého Wacker Neuson dealera, nebo navštivte webové stránky <http://www.wackerneuson.com/>.

FONTOS: A pótalkatrészekre vonatkozó információkért kérjük, forduljon Wacker Neuson kereskedőjéhez vagy látogasson el a Wacker Neuson weboldalára a következő címen: <http://www.wackerneuson.com/>.

Важно! Для ознакомления с информацией о запасных частях, пожалуйста, обратитесь к местному торговому представителю компании Wacker Neuson или посетите веб-сайт <http://www.wackerneuson.com/>.

Σημαντικό : Για πληροφορίες σχετικά με τα ανταλλακτικά, μιλήστε με τον αντιπρόσωπό σας της Wacker Neuson, ή επισκεφθείτε τον ιστότοπο <http://www.wackerneuson.com/>.

Važno : Za rezervne dijelove obratite se svom Wacker Neuson prodavaču ili posjetite mrežne stranice tvrtke Wacker Neuson: <http://www.wackerneuson.com/>.

Önemli : Yedek parça bilgileri için Wacker Neuson Bayinize bakın veya Wacker Neuson web sitesini ziyaret edin. <http://www.wackerneuson.com/>

重要 交換部品の情報については、ワッカーノイソンディーラーにお問い合わせ頂くか、ワッカーノイソンウェブサイト <http://www.wackerneuson.com/> をご覧ください。

重要 有关备件信息，请咨询您的威克诺森经销商或访问威克诺森网站：
<http://www.wackerneuson.com/>。

Important : Pentru informații referitoare la piesele de schimb, vă rugăm să vă adresați distribuitorului Wacker Neuson sau să vizitați site-ul web Wacker Neuson la adresa <http://www.wackerneuson.com/>.

Важно : За информация относно резервни части, моля, обърнете се към местния дилър на Wacker Neuson или посетете уебсайта на Wacker Neuson на адрес <http://www.wackerneuson.com/>.

Free Manuals Download Website

<http://myh66.com>

<http://usermanuals.us>

<http://www.somanuals.com>

<http://www.4manuals.cc>

<http://www.manual-lib.com>

<http://www.404manual.com>

<http://www.luxmanual.com>

<http://aubethermostatmanual.com>

Golf course search by state

<http://golfingnear.com>

Email search by domain

<http://emailbydomain.com>

Auto manuals search

<http://auto.somanuals.com>

TV manuals search

<http://tv.somanuals.com>