



Sno-Thro®

Owner/Operator Manual

Models

932035 - 724

932503 - 724

932101 - 824

932309 - 824

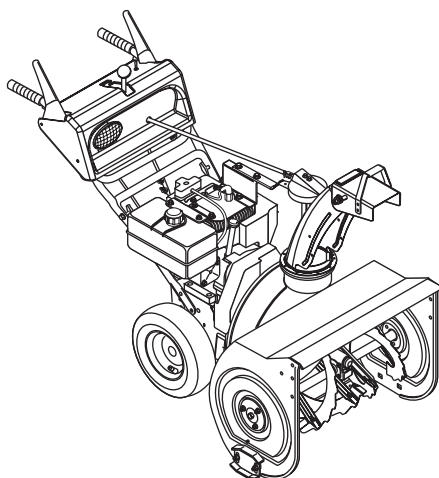

(GB) ENGLISH

(F) FRANÇAIS

(E) ESPAÑOL

Transfer model & serial number label from product registration here.

Coller l'autocollant du modèle et du numéro de série dans cet encadré.

Transferir aquí la etiqueta del modelo y número de serie del registro del producto.

03245600D 4/02
Supersedes 03245600,A,B,C
Printed in USA



Ariens Company
655 West Ryan Street
P.O. Box 157
Brillion, Wisconsin 54110-0157
USA
Telephone (920) 756-2141
Facsimile (920) 756-2407



MODEL CERTIFICATE OF CONFORMITY ISSUED BY THE MANUFACTURER
CERTIFICAT DE CONFORMITÉ DU MODÈLE DÉLIVRÉ PAR LE FABRICANT
MODELL-KONFORMITÄTSBESCHEINIGUNG AUSGESTELLT DURCH DEN HERSTELLER
CERTIFICATO DI COMFORMITÀ DEL MODELLO RILASCIATO DAL PRODUTTORE
CERTIFICADO DE CONFORMIDAD DEL MODELO PROVISTO POR EL FABRICANTE
MODELLSERTIFIKAT FOR OVERENSSTEMMELSE UTSTEDT AV FABRIKANT
TILLVERKARENS MODELLCERTIFIKAT OM ÖVERENSSTÄMMELSE
VALMISTAJAN ANTAMA VAKUUTUS MALLIN MÄÄRÄYSTEN MUKAISUUDESTA

We the undersigned, - Je soussigné, - Mit meiner Unterschrift - Wij de ondergetekenden, - Il sottoscritto, - El abajo firmante - Undertegnede, - Undertecknaren av detta dokument, - Me, allekirjoittaneet,

ARIENS COMPANY, certify that the Snow Thrower - certifie que le chasse-neige - bestätigen daß die Schneefräse, verklaren dat de sneeuwschuíver - certifica che lo spazzavere - certifica que el quita nieves - attesterer at sneslynger - bevítner at snøfreseren - försäkrar att snöslungan, vakuutamme, että lumilinko: :

Category: **WALK BEHIND SNOW THROWER**

Make and **ARIENS**
Trade Name:

Model: 932309 932503
Serial #
Range: 001501 and up 001300 and up

conform to the specifications of directive 98/37/EC and EC directive (EMC) 89/336/EEC as amended by EC directive 92/31/EEC, and 2000/14/EC.

conforme aux spécifications de la directive 98/37/CE et de la directive CE (EMC) 89/336/CE modifiée par la directive CE 92/31/CE et 2000/14/CE.

entsprechen den Spezifikationen der EU-Richtlinien 98/37/EC und (EMC) 89/336/EEC, abgeändert durch EU-Richtlinien 92/31/EEC und 2000/14/EC.

conforme alle specifiche contenute nella direttiva 98/37/EC e nella direttiva CE (EMC) 89/336/EEC, come emendata dalla direttiva 92/31/EEC e dalla 2000/14/EC.

conforme a las especificaciones de la directiva 98/37/EC y directiva EC (EMC) 89/336/EEC como se enmienda por la directiva EC 92/31/EEC, y 2000/14/EC.

følg spesifikasjonene i direktiv 98/37/EF og EF-direktiv (EMC) 89/336/EØF som er endret av EF-direktiv 92/31/EØF, og 2000/14/EF.

uppfyller specifikationerna i direktiv 98/37/EC och EC-direktiv (EMC) 89/336/EEC med ändringar enligt EC-direktiv 92/31/EEC och 2000/14/EC.

vastaa direktiiviä 98/37/EC ja EC direktiiviä (EMC) 89/336/EEC, joissa EC direktiivin 92/31/EEC ja 2000/14/EC muutokset.

Representative Measured Sound Power Level Niveau de puissance acoustique représentatif Repräsentativer gemessener Geräuschpegel Livello di potenza sonora rappresentativo rilevato Nivel de potencia acústica representativo medido Representativt målt lydeffektnivå Representativ uppmätt ljudnivå Edustava, mitattu äänen tehotaso	Guaranteed Sound Power Level - Niveau garanti de puissance acoustique Garantierter Geräuschpegel Livello di potenza sonora garantito Nivel de potencia acústica garantizado Garantert lydeffektnivå Garanterad ljudnivå Taattu äänen tehotaso
932309: 106 dBa 932503: 99 dBa	932309: 108 dBa 932503: 101 dBa

Stated Sound Power Levels are established following Annex V "Internal Control of Production" of directive 2000/14/EC and assessment procedure EN-ISO 3744:1995.

Les déclarations de niveau de puissance acoustique sont établies conformément à l'Article V « Contrôle interne de la production » de la directive 2000/14/CE et de la procédure d'examen EN-ISO 3744:1995.

Die angegebenen Geräuschpegel wurden gem. Anhang V „Internal Control of Production“ (Interne Produktionskontrolle) der Richtlinie 2000/14/EC und dem Bewertungsverfahren EN-ISO 3744:1995 festgelegt.

Il livello della potenza sonora dichiarata viene rilevato in base all'Appendice V del "Controllo Interno di Produzione" della direttiva 2000/14/CE e della procedura di rilevamento EN-ISO 3744:1995

Los niveles de potencia acústica formulados se establecen siguiendo el anexo V "Control interno de producción" de la directiva 2000/14/EC y el procedimiento de evaluación EN-ISO 3744:1995.

Lydeffektnivåene er fastsatt etter tillegg V om "Intern produksjonskontroll" i direktiv 2000/14/EC og vurderingsprosedyren EN-ISO 3744:1995."

Fastställda ljudnivåer har etablerats enligt bilaga V, "Internal Control of Production", i direktiv 2000/14/EC och utvärderingsprocedur EN-ISO 3744:1995.

Mainitut äänen painetasot on mitattu direktiiviä 2000/14/EC vastaavasti ("Internal Control of Production") mittausmenetelmä EN-ISO 3744:1995 käyttäen.

April, 2002 Manager of Product Conformance
Date/Datum/Data/ Position/Qualité/Functie/Qualifica/
Fecha/Dato/Päiväys Puesto/Stilling/Titel/Arvo



Signature/Unterschrift/
Handtekening/Firma/
Underskrift/Underskrift
Handlekening/
Underskrift/Allekirjoitus

⚠ WARNING ⚠

The engine exhaust from this product contains chemicals known to the State of California to cause cancer, birth defects or other reproductive harm.

CONTROLS AND FEATURES

ENGLISH

1. Traction Drive Clutch Lever
2. Ignition Switch, push-pull
3. Choke
4. Throttle (Engine Stop)
5. Runner(s)
6. Axle Lock Pin (932101, 309)
7. Belt Cover
8. Headlight (932101, 309)
9. Discharge Chute Deflector
10. Discharge Chute
11. Impeller
12. Auger
13. Scraper Blade
14. Spark Plug and Wire
15. Primer Bulb
16. Oil Fill and Dipstick
17. Gas Tank and Cap
18. Recoil Starter Handle
19. Attachment Clutch Lever
20. Speed Selector
21. Electric Starter (932035, 101)
22. Chute Crank

FRANÇAIS

1. Levier d'embrayage de l'entraînement de la traction
2. Clé de contact, pousser-tirer
3. Starter
4. Commande des gaz (arrêt du moteur)
5. Patin(s)
6. Broche de blocage de l'essieu (932101, 309)
7. Couvercle du courroie
8. Phare (932101, 309)
9. Déflecteur de la goulotte d'évacuation
10. Goulotte d'évacuation
11. Turbine
12. Rotor
13. Lame racluse
14. Bougie et fil
15. Poire d'amorçage
16. Tube de remplissage en huile et jauge
17. Réservoir de carburant et bouchon
18. Poignée du démarreur à cordon
19. Levier d'embrayage de l'outil
20. Sélecteur de vitesses
21. Démarreur électrique (932035, 101)
22. Manivelle de la goulotte

ESPAÑOL

1. Palanca del embrague de la transmisión de la tracción
2. Interruptor de encendido, tiro-empujel
3. Estrangulador
4. Acelerador (parada de motor)
5. Guía(s)
6. Pasador de traba del eje (932101, 309)
7. Cubierta de la correa
8. Faro (932101, 309)
9. Deflector de la tolva de descarga
10. Tolva de descarga
11. Propulsor
12. Sinfín
13. Cuchilla raspadora
14. Bujía y cable
15. Perilla de cebado
16. Llenado de aceite y varilla medidora
17. Depósito de gasolina y tapa
18. Manilla de arranque de retroceso
19. Palanca del embrague del accesorio
20. Selector de velocidad
21. Arranque eléctrico (932035, 101)
22. Manivela de la tolva

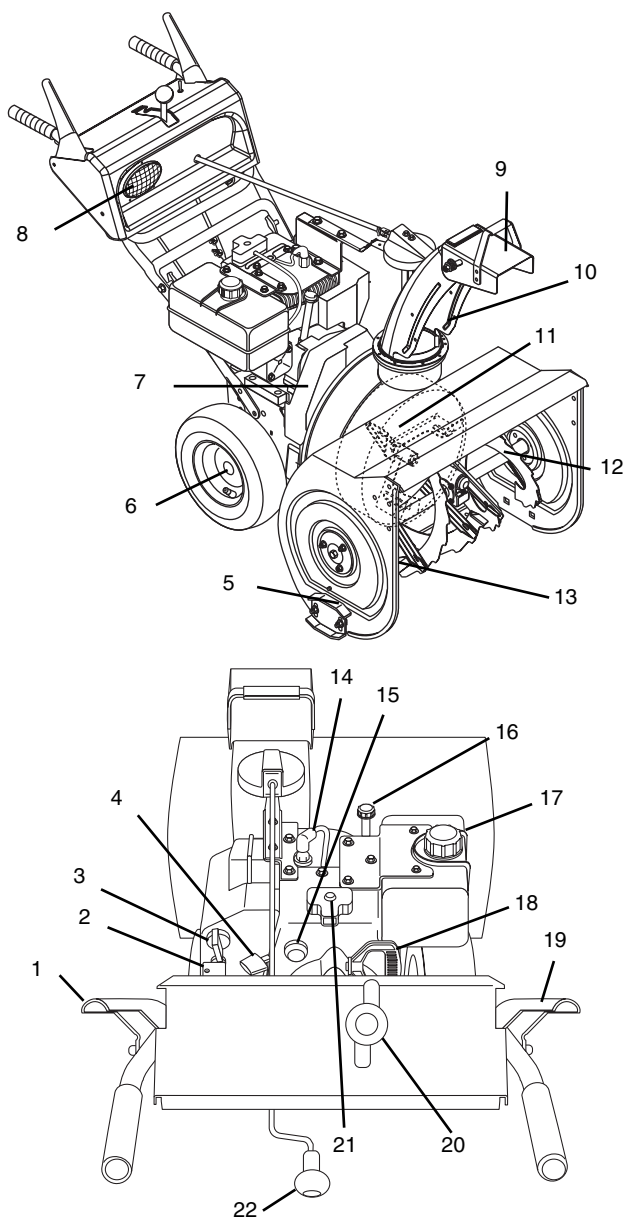

Figure 1

OS0502
OS2100

TABLE OF CONTENTS

Controls and Features	4	Storage	28
Safety	7	Troubleshooting	28
Assembly	12	Service Parts	29
Operation	14	Accessories	29
Maintenance	18	Specifications	30
Service and Adjustments	20	Warranty	31

INTRODUCTION

THE MANUAL

Before operation of unit, carefully and completely read your manuals. If used improperly, this unit could be dangerous and cause personal injury or property damage. The contents will provide you with safety instructions for the safe use of your unit during normal operation and maintenance.

All reference to left, right, front, or rear are given from operator standing in operation position and facing the direction of forward travel.

MODEL AND SERIAL NUMBERS

When ordering replacement parts or making service inquiries, know the Model and Serial numbers of your unit and engine.

Numbers are located on the product registration form in the unit literature package. They are printed on a serial number label, located on the frame of your unit.

- Record Engine Model and Serial number here.

PRODUCT REGISTRATION

A warranty registration card must be filled out, signed, and returned at time of purchase. This card activates the warranty.

UNAUTHORIZED REPLACEMENT PARTS

Use only Ariens replacement parts. The replacement of any part on this vehicle with anything other than an Ariens authorized replacement part may adversely affect the performance, durability, or safety of this unit and may void the warranty. Ariens disclaims liability for any claims or damages, whether warranty, property damage, personal injury or death arising out of the use of unauthorized replacement parts.

For a brief list of replacement parts see *Service Parts* in this manual. To obtain a complete parts manual, find your model and serial number. Then go to www.ariens.com or call 1-800-678-5443.

DISCLAIMER

Ariens reserves the right to discontinue, make changes to, and add improvements upon its products at any time without public notice or obligation. The descriptions and specifications contained in this manual were in effect at printing. Equipment described within this manual may be optional. Some illustrations may not be applicable to your unit.

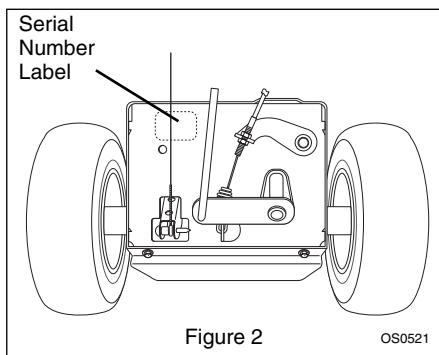

- Record Unit Model and Serial numbers here.

DELIVERY

Customer Note: If you have purchased this product without complete assembly and instruction by your retailer, it is your responsibility to:

1. Read and understand all assembly instructions in this manual. If you do not understand or have difficulty following the instructions, contact your nearest Ariens Dealer for assistance. Make sure all assembly has been properly completed.

NOTE: To locate your nearest Ariens Dealer, call 1-800-678-5443 or go to www.ariens.com on the internet.



WARNING: Improper assembly or adjustments can cause serious injury.

2. Understand all Safety Precautions provided in the manuals.
3. Review control functions and operation of the unit. Do not operate the Sno-Thru unless all controls function as described in this manual.
4. Review recommended lubrication, maintenance and adjustments.
5. Review Limited Warranty Policy.
6. Fill out Original Purchaser Registration Card and return the card to Ariens Company.

SAFETY

SAFETY ALERTS



Look for these symbols to point out important safety precautions. They mean:

Attention!



Personal Safety Is Involved!

Become Alert!

Obey The Message!

The safety alert symbols above and signal words below are used on decals and in this manual. Read and understand all safety messages.



DANGER: IMMINENTLY HAZARDOUS SITUATION! If not avoided, WILL RESULT in death or serious injury.



WARNING: POTENTIALLY HAZARDOUS SITUATION! If not avoided, COULD RESULT in death or serious injury.



CAUTION: POTENTIALLY HAZARDOUS SITUATION! If not avoided, MAY RESULT in minor or moderate injury. It may also be used to alert against unsafe practices.

NOTATIONS

NOTE: General reference information for proper operation and maintenance practices.

IMPORTANT: Specific procedures or information required to prevent damage to unit or attachment.

PRACTICES AND LAWS

Practice usual and customary safe working precautions, for the benefit of yourself and others. Understand and follow all safety messages. Be alert to unsafe conditions and the possibility of minor, moderate, or serious injury or death. Learn applicable rules and laws in your area. Always follow the practices set forth in this manual.

REQUIRED OPERATOR TRAINING

Original purchaser of this unit was instructed by the seller on safe and proper operation. If unit is to be used by someone other than original purchaser; loaned, rented or sold, ALWAYS provide this manual and any needed safety training before operation.

SAFETY DECALS AND LOCATIONS

ALWAYS replace missing or damaged Safety Decals. Refer to figure below for Safety Decal locations.

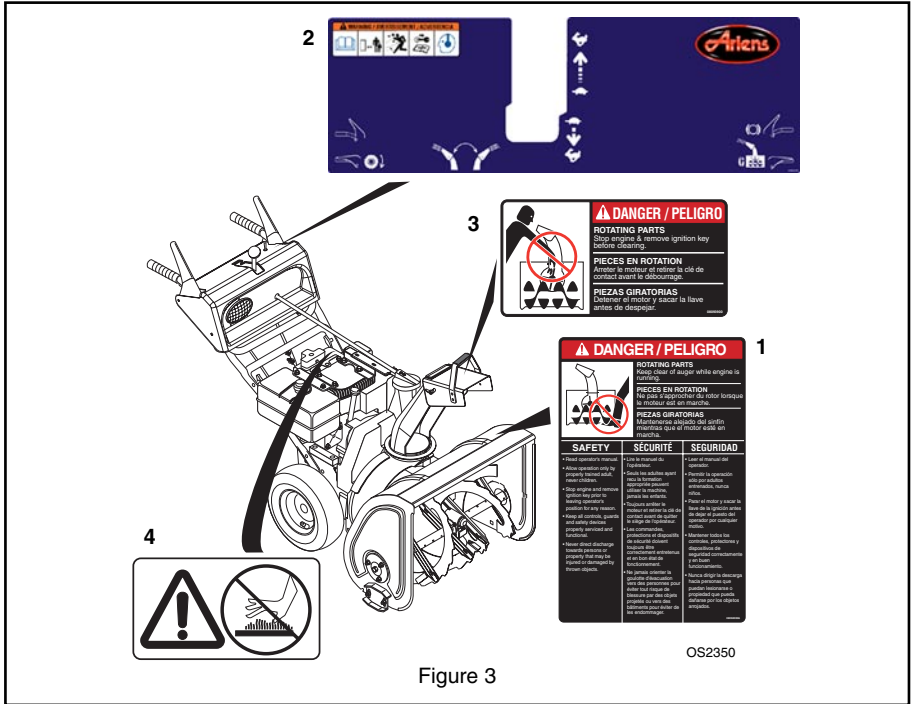

Figure 3

1. DANGER!



ROTATING PARTS.
Keep clear of auger while engine is running.

- Read Operator 's Manual.
- Allow operation only by properly trained adult, never children.
- Stop engine and remove ignition key prior to leaving the operator's position for any reason.
- Keep all controls, guards and safety devices properly serviced and functional.
- Never direct discharge towards persons or property that may be injured or damaged by thrown objects.

2. WARNING!



Read Owner/Operator Manual.

OL1801



Keep people away from unit while operating. Keep children out of work area and under watchful care of a responsible adult.

OL4370



Never direct discharge towards persons or property that may be injured or damaged by thrown objects.

OL0910



OL4010

Stop engine, remove key, read manual before making any repairs, adjustments.



OL4690

Wear appropriate hearing protection.

3. DANGER!



OS2070

ROTATING PARTS! Stop engine and remove key before clearing. **High speed impeller rotates below discharge opening. Wait for all moving parts to stop before removing clogs or servicing.**

4. HOT SURFACES!



OL4340

DO NOT touch parts which are hot from operation. ALWAYS allow parts to cool.

ASSEMBLY SAFETY RULES

Read, understand, and follow all safety practices in Owner/Operator Manual before beginning assembly. Failure to follow instructions could result in personal injury and/or damage to unit.

ALWAYS remove key and/or wire from spark plug before assembly. Unintentional engine start up can cause death or serious injury.

OPERATIONAL SAFETY RULES

Walk Around Inspection

Complete a walk around inspection of unit and work area to understand:

- Work area
- Your unit
- All safety decals

Work Area

ALWAYS check overhead and side clearances carefully before operation. ALWAYS be aware of traffic when operating along streets or curbs.

Keep children and people away. Keep children out of work area and under watchful care of a responsible adult.

NEVER allow children to operate or play on or near unit. Be alert and shut off unit if children enter area.

DO NOT allow adults to operate unit without proper training.

Keep area of operation clear of all toys, pets, and debris. Thrown objects can cause injury.

Check for weak spots on dock, ramps or floors. Avoid uneven work areas and rough terrain. Stay alert for hidden hazards.

Avoid uneven and rough terrain. DO NOT operate near drop offs, ditches, or embankments. Unit can suddenly turn over if a wheel is over the edge of a cliff or ditch, or if an edge caves in.

Falling snow, fog, etc. can reduce vision and cause an accident. Operate unit only when there is good visibility and light.

Personal Safety

Only trained adults may operate unit.

Training includes actual operation.

NEVER operate unit after or during the use of medication, drugs or alcohol. Safe operation requires your complete and unimpaired attention at all times.

NEVER allow anyone to operate this unit when their alertness or coordination is impaired.

DO NOT operate unit without wearing adequate winter outer garments. Wear adequate safety gear, including safety glasses with side shields, and protective gloves. Wear proper footwear to improve footing on slippery surfaces.

DO NOT wear loose clothing or jewelry and tie back hair that may get caught in rotating parts.

Protect eyes, face and head from objects that may be thrown from unit. Wear appropriate hearing protection.

Avoid sharp edges. Sharp edges can cut. Moving parts can cut off fingers or a hand.

ALWAYS keep hands and feet away from all rotating parts during operation. Rotating parts can cut off body parts.

ALWAYS keep hands away from all pinch points.

DO NOT touch unit parts which might be hot from operation. Allow parts to cool before attempting to maintain, adjust or service.

NEVER place your hands or any part of your body or clothing inside or near any moving part while unit is running.

Never direct discharge towards persons or property that may be injured or damaged by thrown objects. Use extreme caution on gravel surfaces. Stay alert for hidden hazards or traffic. Adjust Runners so Scraper Blade does not contact gravel.

DO NOT throw snow any higher than necessary.

Deflected materials can cause injury and property damage.

Always stand clear of the discharge area when operating this unit.

Fumes from engine exhaust can cause injury or death. DO NOT run engine in an enclosed area. Always provide good ventilation.

ALWAYS disengage attachment, stop unit and engine, remove key and allow moving parts to stop before leaving operator's position.

Operation

Read, understand, and follow all instructions in the manual and on the machine before starting.

Understand:

- How to operate all controls
- The functions of all controls
- How to STOP in an Emergency

Rotating impeller can cause serious injury. DO NOT unclog unit while engine is running.

When leaving operator's position for *any reason*, ALWAYS disengage auger, stop unit and engine, remove key and allow moving parts to stop.

Before starting engine, disengage control(s).

Use only approved extension cords and receptacles when starting units equipped with Electric starter. DO NOT connect electric starter cord to any wiring system that is not a three-wire grounded system.

ALWAYS allow unit and engine to adjust to outdoor temperatures before clearing snow.

Always be sure of your footing, especially when operating in reverse or leaving the operator's position. Walk, never run during operation.

DO NOT operate at too fast a rate.

Slow down and turn corners slowly.

Do not operate in reverse unless absolutely necessary. ALWAYS back up slowly. Always look down and behind before and while backing.

Disengage attachment drive when traveling from one work area to another.

Abnormal Vibrations are a warning of trouble. Striking a foreign object can damage unit.

Immediately stop unit and engine. Remove key and wait for all moving parts to stop.

Remove wire from spark plug. Inspect unit and make any necessary repairs before restart.

Before cleaning, removing clogs or making any inspections, repairs, etc.: disengage clutch(es), stop unit and engine, remove key, allow moving parts to stop. Allow hot parts to cool.

Run unit a few minutes after clearing snow to prevent freeze-up of attachment.

Disengage attachment when not in use.

Before starting engine: disengage all clutches and shift into neutral. Adjust runners to clear gravel or crushed rock surfaces safely.

Never leave a running unit unattended.

ALWAYS shut off engine before leaving unit.

ALWAYS remove key to prevent unauthorized use.

Never carry passengers.

Check clutch and brake operation frequently.

Adjust and service as required. All motion of drive wheels and auger/impeller must stop quickly when control levers are released.

Hazardous Slopes

DO NOT operate on steep slopes. DO NOT clear snow across the face of slopes. Keep all movement on slopes slow and gradual. DO NOT make sudden changes in speed or direction. Use a slow speed to avoid stops or shifts on slopes. Avoid starting or stopping on a slope.

DO NOT park unit on a slope unless absolutely necessary. When parking on a slope always block the wheels.

Transport

ALWAYS shut off engine, remove key and drain fuel when transporting unit on a truck or trailer.

Use extra care when loading or unloading unit onto trailer or truck.

Secure unit chassis to transport vehicle.

NEVER secure from rods or linkages that could be damaged.

DO NOT transport machine while engine is running.

Cleaning

Keep unit free of ice or other debris. Clean up oil or fuel spills.

Spark Arrester

This product is equipped with an internal combustion type engine. DO NOT use unit on or near any unimproved, forest-covered or brush covered land unless exhaust system is equipped with a spark arrester meeting applicable local, state or federal laws. A spark arrester, if it is used, must be maintained in effective working order by operator.

FUEL SAFETY RULES

Fuel is highly flammable and its vapors are explosive. Handle with care. Use an approved fuel container.

NO smoking, NO sparks, NO flames. ALWAYS allow engine to cool before servicing.

NEVER fill fuel tank when engine is running or hot from operation.

NEVER fill or drain fuel tank indoors.

Replace fuel cap securely and clean up spilled fuel.

Never fill containers inside a vehicle or on a truck or trailer bed with a plastic liner. Always place containers on the ground away from your vehicle before filling.

When practical, remove gas-powered equipment from the truck or trailer and refuel it on the ground. If this is not possible, then refuel such equipment on a trailer with a portable container, rather than from a gasoline dispenser nozzle.

Keep the nozzle in contact with the rim of the fuel tank or container opening at all times until fueling is complete. Do not use a nozzle lock-open device.

If fuel is spilled on clothing, change clothing immediately.

MAINTENANCE AND SERVICE SAFETY RULES

Before tipping unit up onto housing, remove fuel so no spills will occur and remove battery (if equipped). Ensure unit is secure and will not tip over during maintenance.

ALWAYS keep protective structures, guards, and panels in good repair, in place and securely fastened. NEVER modify or remove safety devices.

DO NOT change engine governor settings or over-speed engine.

Before cleaning, removing clogs or making any inspections, repairs, etc.: disengage clutch(es), stop unit and engine, remove key, allow moving parts to stop. Allow hot parts to cool.

Fumes from engine exhaust can cause injury or death. DO NOT run engine in an enclosed area. Always provide good ventilation.

ALWAYS maintain unit in safe operating condition. Damaged or worn out muffler can cause fire or explosion.

Keep all hardware properly tightened. Check shear bolts frequently.

Maintain or replace safety and instruction labels, as necessary.

STORAGE SAFETY RULES

NEVER store unit with fuel in fuel tank, inside a building where any ignition sources are present.

Allow engine to cool completely before storing in closed area or covering unit.

For extended storage, clean unit thoroughly. See Engine Manual for proper storage.

ACCESSORY AND ATTACHMENT SAFETY RULES

Use only attachments or accessories designed for your unit.

Check components frequently. If worn or damaged, replace with manufacturer's recommended parts.

ASSEMBLY



WARNING: AVOID INJURY. Read and understand *Assembly and Fuel Safety Rules* before proceeding.



WARNING: Dropping or tipping over boxed unit could result in personal injury or damage to unit.

Tools Required:

- Pliers
- Open-End Wrenches: 3/8, 7/16, 1/2, 9/16" and/or Adjustable Wrench
- Tire Gauge

ASSEMBLY

Handlebar and Shift Rod

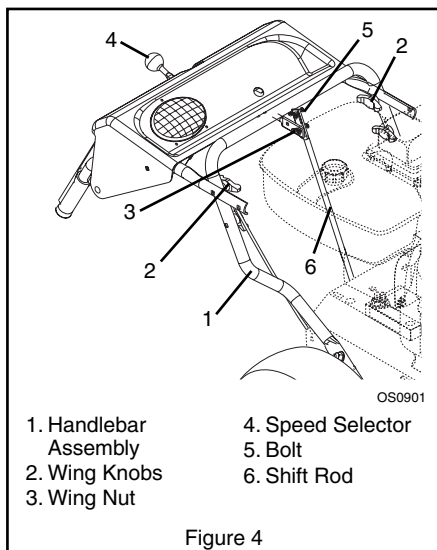

Figure 4

1. Remove lower wing knobs on handlebar assembly (Figure 4).
2. Remove upper wing nut and bolt on shift rod.
3. Loosen upper wing knobs on handlebar.
4. Loosen lower wing nut and bolt on shift rod.
5. Put speed selector lever into fastest reverse panel notch.
6. Rotate handlebar up so wing knob holes align. Install and tighten all wing knobs.

7. Install wing nut and bolt removed in step 2 onto shift rod and tighten hardware.

Install Discharge Chute and Crank

Figures 5 and 6.

1. Grease discharge chute ring on blower housing (if not already greased).
2. Remove mounting hardware from top of engine.
3. Slide chute ring under retainer clip on blower housing and put chute on housing.
4. Secure chute by fastening chute strap to engine with hardware just removed.

NOTE: Washers and lock nuts go on top of chute strap.

5. Loosen mounting nut on chute and move chute up or down so that chute ring is approximately centered between retainer clip and lower ring and tighten.
6. Slide chute crank rod through bracket under handlebar and through hole in panel.
7. Align chute crank rod with the universal joint on chute and fasten with spring clip.

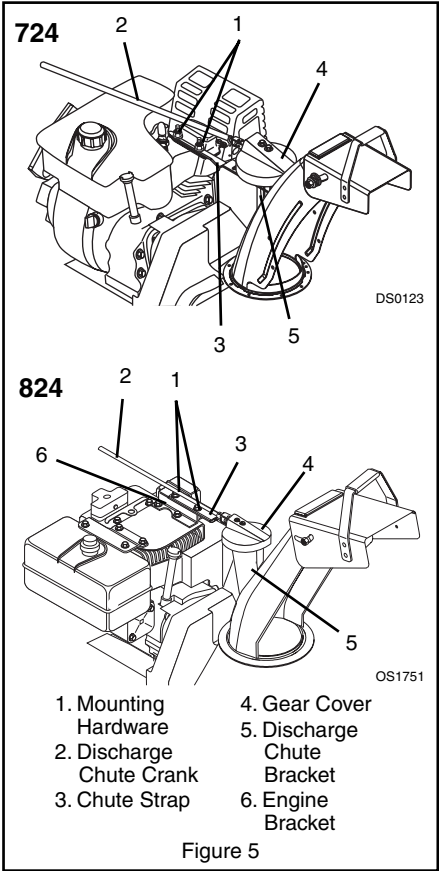

Figure 5

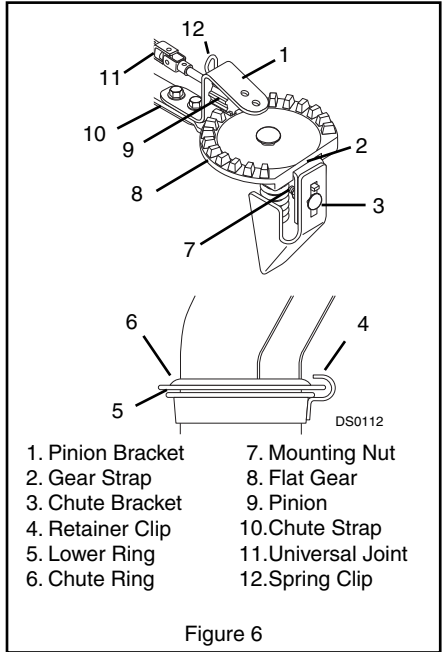

Figure 6

Check Function of Dual Handle Interlock (932101, 309)

Without the engine running, press down (engage) both clutch levers. Release attachment clutch lever. Attachment clutch should remain engaged until traction clutch lever is released, then both clutches *must* disengage. If they do not, contact your dealer for repairs.

Check Tire Pressure

Check tire pressure and adjust to the pressure listed on tire sidewall.

Check Auger Gearcase Oil

Check oil level in auger gearcase (see *Service and Adjustments*).

Check Engine Crankcase Oil

IMPORTANT: Engines on all Sno-Thro models 932101 and 932309 are shipped with 5W-30 oil in crankcase. Refer to Engine Manual for detailed instructions.

Fill Engine Fuel Tank

Refer to Engine Manual for proper fuel type and tank capacity.

Check Function of all Controls

Ensure unit runs and performs properly. Refer to *Operation*.

Run in Attachment Belt

1. Start unit in a well-ventilated area according to *Starting and Shut-Off in Operation*.
2. Engage attachment clutch lever and run attachment for about 15 minutes.

3. Stop unit, wait for all moving parts to stop, and remove spark plug wire.
4. Adjust clutch according to *Attachment Clutch/Brake Adjustment in Service and Adjustments*.

OPERATION



WARNING: AVOID INJURY. Read and understand *Operational and Fuel Safety Rules* before proceeding.

CONTROLS AND FEATURES

See Figure 1 for all Controls and Features locations.

Dual Handle Interlock (932101, 309)

When Attachment Clutch and then Traction Drive Clutch are engaged, the Attachment Clutch will remain engaged (lever down) if released. To stop attachment, release Traction Drive Clutch and both clutches will disengage.

Traction Drive Clutch - Left Hand Lever

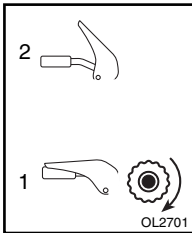

Squeeze the Traction Drive Clutch Lever against the Handlebar (1) to engage wheel drive for propelling unit. Forward speed will vary according to snow depth and moisture content. Release lever (2) to stop movement.

NOTE: When traveling to or from the area to be cleared, press down on the handlebars enough to raise the front of the unit slightly off the surface. Engage the traction drive clutch without engaging the attachment drive clutch.

Attachment Clutch - Right Hand Lever

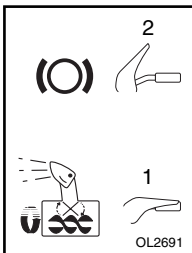

Squeeze Attachment Clutch Lever against handlebar (1) to engage attachment. Release both clutch levers (2) to disengage power and apply brake to attachment.

IMPORTANT: If the belt squeals when the attachment clutch lever is engaged, the attachment drive may be frozen. Immediately release the attachment clutch lever and move the unit into a heated area to thaw.

Ignition Switch



Key Switch has two positions:

1. "Stop" - pulled out
2. Run - pushed in

NOTE: DO NOT twist key after it is inserted.

Primer Bulb



Pushing the primer bulb in adds fuel for easier engine start. Refer to *Starting and Shut Off*.

Speed Selector

The Speed Selector controls the unit travel in a forward or reverse direction when positioned in notch of speed.

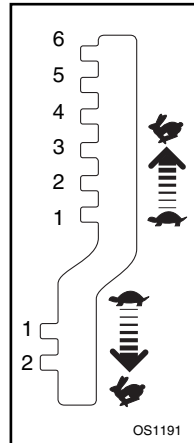

Forward:

(6) Fastest

(1) Slow

Reverse:

(1) Slow

(2) Fast

IMPORTANT: DO NOT change motion from forward to reverse with clutch engaged. Forward speed can be changed without declutching.

Choke Control Knob

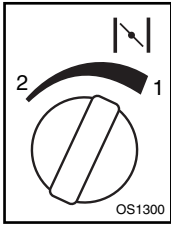

1. Choke Closed position: chokes off air to engine for easier start.
2. Choke Open position: allows for normal operation.

IMPORTANT: Gradually open choke after engine starts.

Throttle

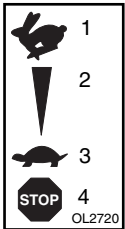

The throttle controls the engine speed. To increase or decrease the engine speed, adjust to:

1. Fast (normal or warm starts)
2. Part-Throttle
3. Slow (cold weather starts)
4. Stop (engine is off)

Electric Starter (932035, 101)

The electric starter will start a properly choked and cranked engine when the starter button is pushed. Refer to *Starting and Shut-Off*.

Recoil Starter Handle

When pulled, handle will turn engine over.

IMPORTANT: DO NOT let handle snap back against starter.

Discharge Chute Deflector

ALWAYS position discharge chute deflector at a safe angle before starting engine.

DO NOT throw snow any higher than necessary.

Push deflector handle forward or down to throw snow lower. Pull deflector handle up or to the rear to throw snow higher.

IMPORTANT: If Chute Deflector does not stay in set position, adjust as directed in *Service and Adjustments*, or repair before operation.

Discharge Chute

Discharge chute rotates 220°.

ALWAYS position discharge chute in safe direction and angle, away from operator and bystanders, before starting engine.

Chute Crank

IMPORTANT: If chute does not stay in set position, adjust as directed in *Service and Adjustments*, or repair before operation.

Rotate the Chute with Discharge Chute Crank Handle.

IMPORTANT: DO NOT force frozen chute controls. Start engine and run for 3-5 minutes to thaw. If still frozen, take to warm place until controls are free.

Axle Lock Pin (932101, 309)

The axle lock pin is located on the right wheel hub. Moving pin from the hub to the axle shaft allows the right wheel to turn freely.

Scraper Blade

The scraper blade allows the back of the housing to keep better contact with the surface being cleared. It also prevents damage to the housing from normal wear.

IMPORTANT: DO NOT allow Scraper Blade to wear too far or Auger/Impeller housing will become damaged.

Runners

The runners control the distance between the scraper blade and the ground. Adjust runners equally to keep blade level with the ground. Refer to *Pre-Start* for recommended settings.

FILLING FUEL TANK

WARNING: AVOID INJURY. Read and understand *Fuel Safety Rules* in *Safety* section before proceeding.

To add fuel to fuel tank:

1. ALWAYS place unit in open or well ventilated area.
2. Stop engine and allow to cool.
3. Clean Fuel Cap and surrounding area to prevent dirt from entering Fuel Tank.
4. Remove Cap.

IMPORTANT: DO NOT use gasohol or gasoline containing alcohol. See Engine Manual for correct type and grade of fuel.

5. Fill fuel tank to within 1/2 in (1,2 cm) below bottom of filler neck with unleaded gasoline.

NOTE: 932101 and 309 tank capacity is 1 gallon (3.8 liters). Tank capacity of other models is 3.5 quarts (3,3 liters).

6. Replace Fuel Cap and tighten.
7. ALWAYS clean up any spilled fuel.

PRE-START

1. Frozen Impeller

IMPORTANT: Before starting engine, check impeller to be sure it is not frozen.

To check impeller:

1. With key in "Stop" position, squeeze Attachment Clutch Lever to Engaged position.
2. Pull Recoil Starter Handle.
3. If Impeller is frozen, (cannot pull Starter Handle) move unit to a heated area and thaw to prevent possible damage.

2. Check Function of Clutches (932035, 503)

If clutches do not engage or disengage properly, adjust or repair before operation (see *Service and adjustments*).

3. Check Dual Handle Interlock (932101, 309)

Without the engine running, press down (engage) both clutch levers. Release attachment clutch lever. Attachment clutch should remain engaged until traction clutch lever is released, then both clutches *must* disengage.

If clutches do not engage or disengage properly, adjust or repair before operation (see *Service and Adjustments*).

4. Adjust Axle Lock (932101, 309)

Keep locking pin on the right wheel hub for best traction when throwing snow.

5. Adjust Runners

Check and adjust Runners (see *Service and Adjustments*). Allow 1/8 in (3 mm) between scraper blade and hard, smooth surface(s). Allow 1-1/4 in (30 mm) between scraper blade and uneven or gravel surfaces.

6. Check Engine Fuel & Crankcase Oil



WARNING: AVOID INJURY. Read and understand *Fuel Safety Rules* in *Safety* section before proceeding.

Check and add fuel if required. Check that the engine crankcase oil is full using dipstick. Refer to Engine Manual for detailed instructions.

TO STOP IN AN EMERGENCY

Immediately release both control levers to stop unit in an emergency. Stop engine, remove key and wait for all rotating parts to stop before leaving operator's position.

STARTING AND SHUT OFF



WARNING: FAILURE TO FOLLOW INSTRUCTIONS could result in personal injury and/or damage to unit. **DO NOT** attempt to start your unit at this time. Read entire Owner/Operator Manual and the Engine Manual first.

IMPORTANT: Allow unit and engine to adjust to the outdoor temperatures before clearing snow. Before shut-off, run the attachment a few minutes to prevent freeze-up.

NOTE: Try out each control without the engine running to see how it works and what it does.

Manual Start

1. Turn discharge chute straight ahead.
2. Make sure that the traction clutch and attachment drive clutch levers are fully disengaged.
3. Push Primer Bulb 2 or 3 times for cold engine.

NOTE: When temperature is below -15° F (-26° C) additional priming may be needed.

4. If engine is cold, apply choke. See Engine Manual for detailed instructions.

NOTE: A warm engine requires less choking than a cold engine.

5. Set throttle to proper starting position.
6. Insert key into ignition switch and push into RUN position. **DO NOT** twist key after it is inserted.
7. Grasp starter handle and pull rope out slowly until it pulls harder. Let rope rewind slowly.
8. Pull rope with a rapid continuous full arm stroke. Let rope rewind slowly.

IMPORTANT: **DO NOT** let Starter Handle snap against Starter.

9. Repeat steps 7 and 8 until engine starts. (If engine does not start, refer to *Troubleshooting*.)
10. Adjust choke as needed.
11. Set throttle to Part Throttle or Slow position for adaptation to outside temperature or travel. Set throttle to Fast position for normal operation.

Electric Start (120V or 240V) (932035, 101, optional on 309, 503)

1. Connect extension cord to prongs on starter.

IMPORTANT: Prevent damage to unit. Know voltage of your starter and only use matching outlets.

2. Plug extension into:
240V 3-wire, grounded outlet.
120V 3-wire, grounded outlet.
3. Turn discharge chute straight ahead.
4. Make sure that the traction clutch and attachment drive clutch levers are fully disengaged.
5. Push Primer Bulb 2 or 3 times for cold engine.

NOTE: When temperature is below -15° F (-26° C) additional priming may be needed.

6. Insert key into ignition switch on engine and push into "Run" position. DO NOT twist key after it is inserted.
7. If engine is cold, apply choke. A warm engine requires less choking than a cold engine. See Engine Manual for detailed instructions.
8. Set throttle to proper starting position.
9. Press starter button on engine until engine starts.

IMPORTANT: DO NOT operate starter more than 15 seconds per minute, as overheating and damage can occur. (If engine does not start, refer to *Troubleshooting*.)

10. Adjust choke as needed.
11. Disconnect power cord from outlet, then starter.
12. Set throttle to Part Throttle or Slow position for travel or adaptation to outside temperature. Once achieved, set throttle to Fast position for normal operation.

Shut Off

1. Release Traction Drive Clutch Lever and allow unit to come to a complete stop.
2. Run Impeller a few minutes after use to prevent freeze-up of Impeller.
3. Release Attachment Clutch Lever and wait for all moving parts to come to a complete stop.
4. Move Throttle to the "Stop" position.
5. Remove key.

SNOW REMOVAL

IMPORTANT: Allow unit and engine to adjust to the outdoor temperatures before clearing snow.

NOTE: Attachment clutch should be engaged before wheel drive clutch when throwing snow.

1. Select Speed Control position and direction.
2. Engage Attachment Clutch - Right Hand Lever.
3. Engage Traction Drive Clutch - Left Hand Lever.

IMPORTANT: DO NOT overload unit capacity by attempting to clear snow at too fast a rate. Use slow speed to clear deep or hard packed snow.

Tips for Operation

Snow is best removed as soon as possible after snow fall.

To clear an area, run unit in an overlapping series of paths. For large areas; start in the middle and throw snow to each side, so snow is not cleared more than once.

ALWAYS direct snow away from area to be cleared and with direction of the wind.

TRAVELING

To travel from one work area to another:

1. Set Throttle to Slow or Part-Throttle position.
2. Press down on handlebars enough to raise front of unit slightly off surface.
3. Engage wheel drive clutch without engaging attachment drive clutch.

TRANSPORT

ALWAYS shut off engine, remove key and drain fuel when transporting unit on a truck or trailer.

Use extra care when loading or unloading unit onto trailer or truck.

Secure unit chassis to transport vehicle. NEVER secure from rods or linkages that could be damaged.

DO NOT transport machine while engine is running.

MAINTENANCE

Ariens Dealers will provide any service or adjustments which may be required to keep your unit operating at peak efficiency. Should engine service be required, contact an Ariens dealer or an authorized engine manufacturer's service center.



WARNING: AVOID INJURY. Read and understand *Maintenance and Service Safety Rules* in *Safety* section before attempting any maintenance.

SERVICE POSITION



WARNING: Before tipping unit up onto housing, remove fuel so no spills will occur. Ensure unit is secure and will not tip over during maintenance.

Place unit on a flat level surface. Tip unit forward onto front of impeller housing for service. Assure unit is secure and will not tip over. Strap and clamp onto bench if needed.

MAINTENANCE SCHEDULE

The chart below shows the recommended maintenance schedule that should be performed on a regular basis. More frequent service may be required.

MAINTENANCE SCHEDULE

Service Performed	Each Use	Every 5 hrs.	Every 25 hrs.	Yearly
Check Dual Handle Interlock	•			
Check Fasteners	•			
Check Clutches	•			
Clean Engine	•			
Check Engine Oil		•		
Change Engine Oil		*	•	
Check Tire Pressure			•	
Check Auger Gearcase			•	•
General Lubrication			•	•

* After first two hours of operation.

CHECK DUAL HANDLE INTERLOCK

Without the engine running, press down (engage) both clutch levers. Release attachment clutch lever. Attachment clutch should remain engaged until traction clutch lever is released, then both clutches *must* disengage.

CHECK FASTENERS

Make sure all hardware is tightened properly.

CHECK CLUTCHES

Auger / impeller must stop within 3 seconds when attachment clutch/impeller brake lever is released.

Wheels must stop quickly when traction drive clutch lever is released.

If clutches do not engage or disengage properly, adjust or repair before operation (see *Service and Adjustments*).

CLEAN ENGINE

Refer to Engine Manual for detailed instructions.

CHECK ENGINE OIL

The engine crankcase oil should be checked every 5 hours of operation. Oil level **MUST** be maintained in safe operating range on dipstick at all times or engine damage will result (See Engine Manual).

Park unit on a level surface. Refer to Engine Manual for detailed instructions.

CHANGE ENGINE OIL

Change oil after first 2 hours of operation, thereafter change oil every 25 hours (more often if required). Refer to Engine Manual for detailed instructions.

Run engine just prior to changing oil. Warm oil will flow more freely and carry away more contamination.

CHECK TIRE PRESSURE

Keep tires at pressure listed on the tire sidewall.

CHECK AUGER GEARCASE

IMPORTANT: Proper oil level must be maintained.

Gear cases are filled to the correct level at the factory. Unless there is evidence of leakage, no additional lubricant should be required.

Check oil level each season or every 25 hours of operation.

To ensure adequate lubricant level:

1. Remove filler plug (Figure 7). Lubricant must be at least up to bottom of lubricant filler hole with unit resting on a level-surface.
2. Add lubricant if required. Allow oil to drain to level of plug and replace plug.

IMPORTANT: Use only Ariens special gear lubricant L-2 (Part Number 00008000).

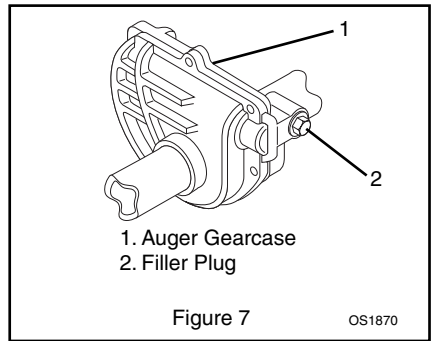

GENERAL LUBRICATION

IMPORTANT: Wipe each fitting clean before and after lubrication.

IMPORTANT: DO NOT allow grease or oil to get on friction disc, friction plate or belts.

NOTE: Apply Stens Mix Hi-Temp Grease or equivalent to the lubrication fittings. See *Service Parts*.

Sno-Thro should be lubricated (Figure 8) at beginning of season or every 25 operating hours.

Auger Shaft

NOTE: To grease auger shaft, remove shear bolt nuts, and shear bolts. Turn auger on shaft while applying grease at zerk fittings. Replace shear bolt per instructions in *Service and Adjustments*.

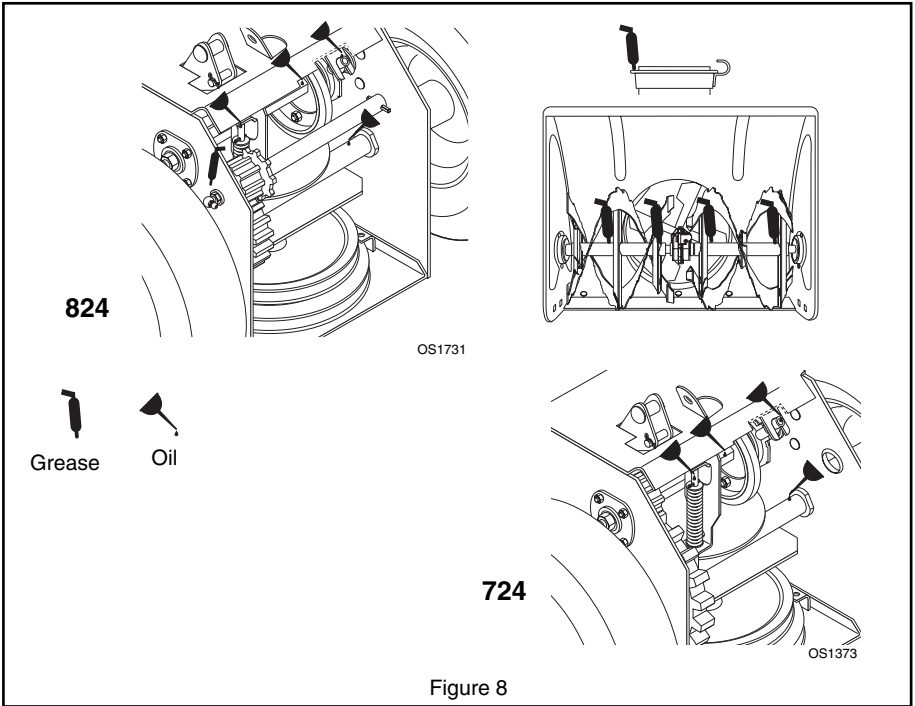

Figure 8

SERVICE AND ADJUSTMENTS

WARNING: AVOID INJURY. Read and understand *Maintenance and Service Safety Rules* in *Safety* section before attempting service or adjustments.

DISCHARGE CHUTE DEFLECTOR

Deflector must stay in selected position while throwing snow.

To adjust, loosen then retighten hardware to desired deflector drag force (Figure 9).

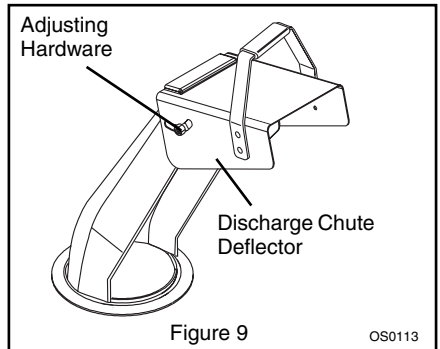

Figure 9

OS0113

DISCHARGE CHUTE

If chute does not stay in position while operating, tighten nut on carriage bolt at pivot point to increase tension on spring (Figure 10). Smooth and easy rotation of properly lubricated chute with crank is obtained by adjusting pinion and chute gear teeth so they mesh together.

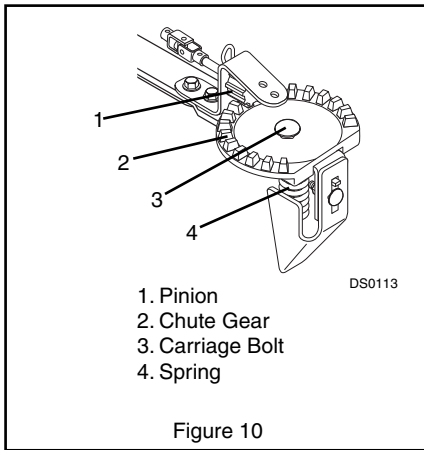

Figure 10

SCRAPER BLADE

IMPORTANT: Damage to auger/impeller housing will result if blade wears down too far. Scraper blade is adjustable to compensate for wear.

To adjust scraper blade:

1. Tip unit back onto handlebar, support housing and loosen nuts retaining blade.
2. Adjust runners to fully raised position (housing closest to ground).
3. Reposition scraper blade flush with runners and tighten lock nuts.

SHEAR BOLTS

IMPORTANT: Use only Ariens shear bolts for replacement. Use of any other type of shear bolt may result in severe damage to unit.

Occasionally a foreign object may enter the auger/impeller housing and jam the auger, breaking shear bolts (Figure 12) which secure the auger to the shaft. This allows auger to turn freely on the shaft preventing damage to gear drive.

For Replacement:

1. Slide auger outward against roll pin and align hole in shaft with hole in auger (holes in shaft for roll pins and shear bolts line up).
2. Drive shear bolt through hole (if shear bolt was broken this will drive remaining part from shaft).
3. Secure shear bolt with nut.

RUNNERS

Runners should be adjusted (Figure 11) as conditions require.

1. Position unit on a hard, flat, smooth level surface.
2. Adjust runners by inserting a spacer of desired thickness under center of scraper blade, loosen runner hardware, slide runners to flat surface. Allow 1/8 in (3 mm) between scraper blade and hard smooth surfaces. Allow 1-1/4 in (30 mm) between scraper blade and uneven or gravel surfaces. Retighten hardware.

NOTE: Keep housing level by adjusting runners equally.

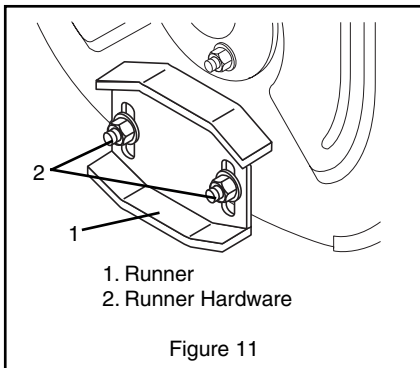

Figure 11

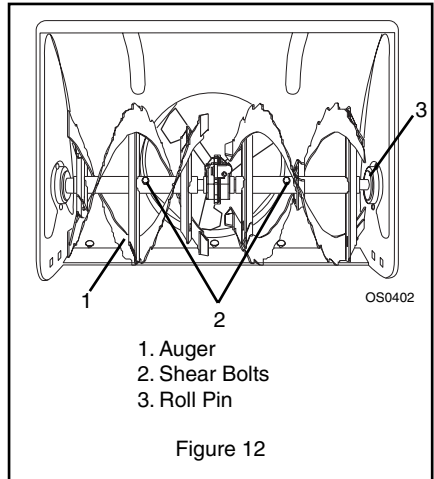
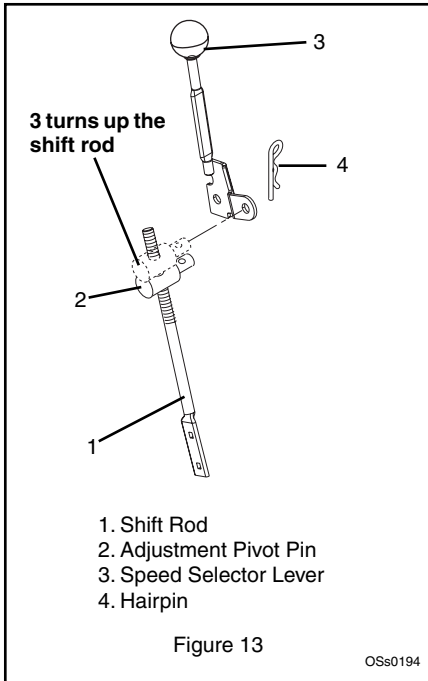

Figure 12

SPEED SELECTOR ADJUSTMENT



To adjust (Figure 13):

1. Remove hair pin from adjustment pivot pin.
2. Pull shift rod and adjustment pivot pin out of speed selector lever.
3. Place the speed selector in the fastest reverse speed position.
4. Pull the shift rod straight up towards the control panel as far as it will go.
5. Thread the adjustment pivot pin along the shift rod until it aligns with the mating hole on the speed selector lever.
6. Turn adjustment pivot pin three turns up the shift rod (Figure 13).
7. Reinsert the pivot pin into the hole on the speed selector lever.
8. Check forward and reverse speeds.
 - a. Start unit.
 - b. Shift speed selector into first forward speed.
 - c. Engage traction clutch. Unit should move forward.
 - d. Stop unit.
 - e. Shift speed selector into first reverse speed.

f. Engage traction clutch. Unit should move backward.

g. Shut off unit.

9. Adjust pivot pin as needed so unit travels forward when speed selector lever is in first forward position and backward when speed selector lever is in first reverse position.

10. Secure adjustment pivot pin to speed selector lever with hairpin.

ATTACHMENT DRIVE BELT REPLACEMENT

Remove Attachment Drive Belt

(Figures 14 and 15)

1. Shut off engine, remove key, disconnect spark plug wire and allow unit to cool completely.
2. Remove two screws securing belt cover to unit and remove belt cover.
3. Remove spring pin from chute crank rod assembly at universal joint and separate.
4. Remove hardware holding chute strap to engine mounting bracket and lift discharge chute off housing.
5. Remove belt finger by removing cap screws mounting belt finger to engine.
6. Remove attachment drive belt from engine sheave (it may be necessary to turn engine sheave using recoil starter handle).



CAUTION: Always support Sno-Thro frame and housing when loosening the cap screws holding them together. Never loosen cap screws while unit is in service position.

IMPORTANT: To avoid bending bottom cover, when tipping unit apart, support handlebars firmly or tip unit up on housing and remove bottom cover by removing four cap screws before separating unit.

7. Support Sno-Thro frame and housing.
8. Remove top two cap screws and loosen lower cap screws holding blower housing to frame (one on each side).
9. Separate housing from unit. Lower handlebar on floor.
10. Remove attachment drive belt from lower pulley (hold brake away from belt).

Replace Attachment Drive Belt

1. Place new belt onto lower pulley and while holding brake out of way, tip unit together.
2. Secure blower housing to frame with cap screws.
3. Place belt onto engine sheave.
4. Make sure engine sheave and attachment pulley align. If alignment is necessary, loosen engine sheave set screws, reposition sheave and retighten set screws.
5. Replace belt finger.

IMPORTANT: BELT FINGER MUST BE between 1/16 to 1/8 in (1.6–3 mm) from belt with attachment clutch engaged or belt grabbing may occur causing impeller to rotate while attachment clutch is disengaged (Figure 15).

6. Adjust clutch per *Attachment Clutch/ Impeller Brake Adjustment* below.
7. Reinstall chute strap and mounting hardware onto engine.
8. Replace chute crank and secure with spring pin.
9. Replace belt cover and secure with screws.

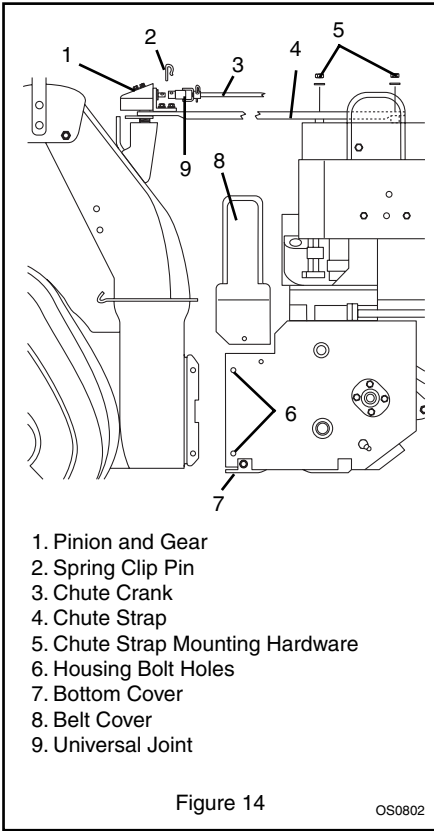

1. Pinion and Gear
2. Spring Clip Pin
3. Chute Crank
4. Chute Strap
5. Chute Strap Mounting Hardware
6. Housing Bolt Holes
7. Bottom Cover
8. Belt Cover
9. Universal Joint

Figure 14

OS0802

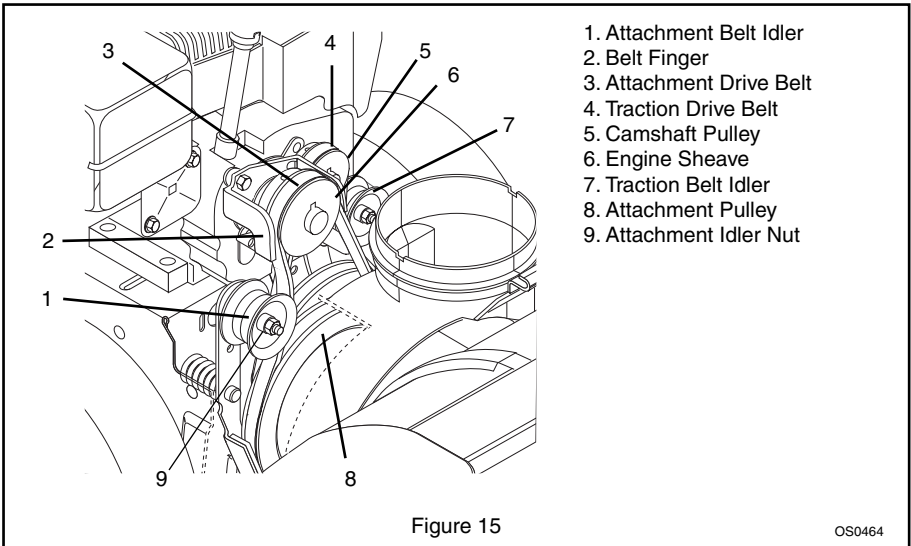

1. Attachment Belt Idler
2. Belt Finger
3. Attachment Drive Belt
4. Traction Drive Belt
5. Camshaft Pulley
6. Engine Sheave
7. Traction Belt Idler
8. Attachment Pulley
9. Attachment Idler Nut

Figure 15

OS0464

TRACTION DRIVE BELT REPLACEMENT

NOTE: Housing and frame must be tipped apart and attachment drive belt removed from engine sheave in order to change traction drive belt (Figures 14 & 15).



CAUTION: Always support Sno-Thru frame and blower housing when loosening the cap screws holding them together. Never loosen cap screws while unit is in service position.

1. Remove attachment drive belt (See *Remove Attachment Drive Belt*).
2. Pull idler away from traction drive belt and remove belt from idler, camshaft pulley and driven pulley (it may be necessary to turn camshaft pulley using recoil starter handle).

NOTE: To gain clearance, engage traction clutch and if necessary pull back attachment idler arm clevis pin.

3. Replace traction drive belt making sure pulleys align. If alignment is necessary, loosen camshaft pulley set screws, reposition pulley and retighten set screws.
4. Replace attachment drive belt (See *Replace Attachment Drive Belt*).

ATTACHMENT CLUTCH/BRAKE ADJUSTMENT



WARNING: IMPROPER ADJUSTMENT could result in unexpected movement of auger and impeller causing death or serious injury. Auger / impeller must stop within 3 seconds when Attachment Clutch/Impeller Brake lever is released.



WARNING: Adjustment procedure requires the engine to be run with the belt cover off. Read, understand and follow all *Operational, Fuel and Maintenance and Service Safety Rules* before adjusting your unit.

1. Remove belt cover.
2. Check belt alignment (Figure 15).
Engine sheave and attachment pulley must align vertically. Also, belt must be centered in the idler pulley.

To align, move engine sheave:

- a. Loosen set screws.
- b. Slide sheave and key to desired position.
- c. Tighten set screws.

3. Adjust cable slack.

IMPORTANT: The clutch cable must be slack when lever is disengaged.

- a. With the clutch lever disengaged, loosen control cable mounting nuts (Figure 18).
 - b. Pull up on cable body to remove cable slack.
 - c. Finger tighten mounting nuts, and then loosen the top nut two turns.
 - d. Tighten the bottom nut with a wrench.
4. Check attachment clutch lever measurement.
 - a. Start engine and run at full throttle.
 - b. Slowly squeeze the attachment clutch lever until auger shaft begins to rotate.
 - c. Measure the distance from the end of the clutch lever to the hand grip as shown in Figure 17. The distance between the clutch lever and the hand grip should be $4-1/2 \pm 1/8$ in (11.43 ± 3 mm).
 - d. Shut off engine.
 5. Adjust attachment clutch lever measurement, if necessary.

NOTE: 1/16 in (1.6 mm) idler movement will change clutch lever measurement about 1/4 in (6 mm).

- a. Loosen idler nut (Figure 15).
 - b. To increase distance between clutch lever and hand grip, move the idler towards the attachment belt.
 - c. To decrease the distance between the clutch lever and hand grip, move the idler away from the attachment belt.
 - d. Tighten idler adjustment nut.
 - e. Check clutch lever measurement.
6. Check Brake

When the clutch lever is disengaged, the brake must contact the attachment belt.

When the clutch lever is engaged, the brake must be more than 1/16 in (1.6 mm) away from the belt (Figure 16).

7. Repeat steps 4–6 until attachment clutch distance and brake contact are correct.

IMPORTANT: If attachment clutch/brake cannot be adjusted within tolerances, see your Dealer for repairs.

8. Check belt finger clearance.

With clutch lever engaged, belt fingers should be $1/16$ – $1/8$ in (1.6–3 mm) from belt. Adjust belt fingers as necessary.

9. Replace belt cover.

10. Check that auger/impeller stops within 3 seconds after attachment clutch/impeller brake bail is released.

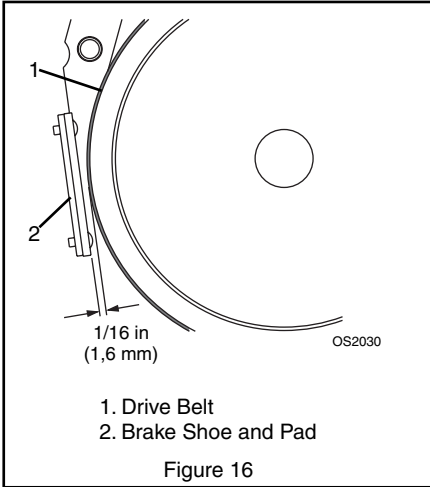

TRACTION DRIVE CLUTCH ADJUSTMENT

If drive slips, adjust traction clutch to compensate for friction disc wear.

To test traction clutch (Figure 17):

1. Put unit in first forward speed.
2. Without engine running, push unit forward while slowly moving the traction drive clutch lever toward the handle grip.
3. Measure distance between lever and handlebar when the wheels brake. If distance is not $6-1/8$ in $\pm 1/4$ in (15.5 cm ± 6 mm), adjust the traction clutch.

To adjust traction clutch (Figure 18):

1. Loosen jam nut on traction cable adjustment barrel.
2. Turn the adjustment barrel up the cable to decrease the distance between clutch lever and handlebar.
Turn the adjustment barrel down the cable to increase the distance between clutch lever and handlebar.
3. Check traction clutch lever distance and repeat adjustment steps if necessary.
4. Tighten jam nut on traction cable adjustment barrel.

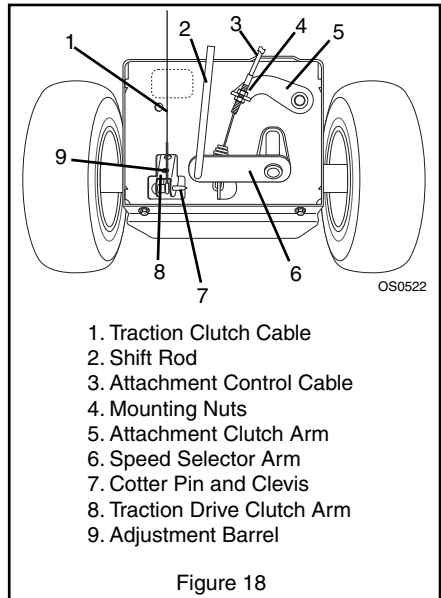
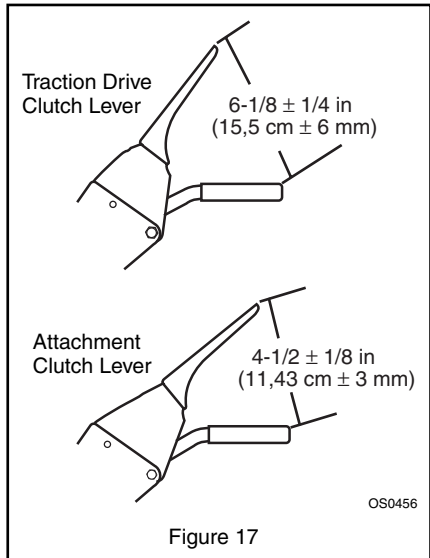

FRICION DISC REPLACEMENT (932035, 503)

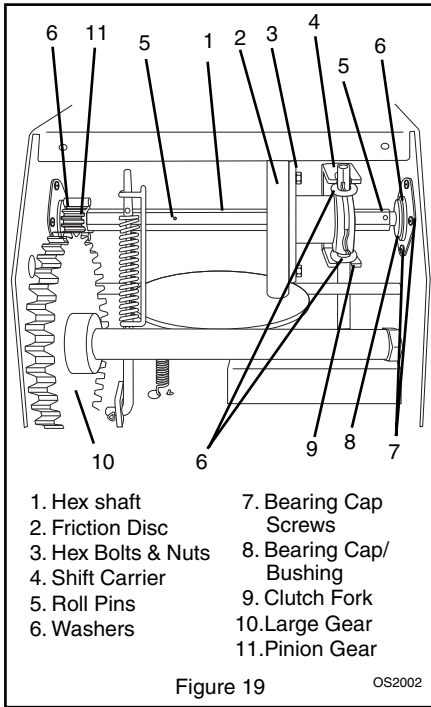

Remove Friction Disc

(Figure 19):

1. Shut off engine, remove key, disconnect spark plug wire and allow unit to cool completely.



CAUTION: Before tipping unit, remove enough fuel so that no spills occur.

2. Tip the unit up onto front housing on a level surface.
3. Remove locknut and bolts from wheel axles and remove wheels.
4. Remove two (2) bolts from top of bottom cover.
5. Loosen two (2) bottom screws and slide cover off.
6. Remove hair pin and washer from shift rod. Disconnect shift rod from lower speed selector arm. Reinstall hairpin and washer on rod.
7. Remove four (4) nuts from bearing cap on left side of unit.

8. Reinstall one nut to keep the inside bearing cap in place.
9. Remove bearing cap/bushing and washer from right side of unit.
10. Reinstall nuts on screws through side frame to keep screws in place.
11. Carefully tap two (2) roll pins out of center and right end of shaft.
12. Slide friction disc assembly and hex shaft to the right until the left end of shaft is clear of left bearing. Tap lightly if necessary, to loosen. The shaft slides out of the small pinion gear and washer.
13. Carefully lift shaft and friction disc out of unit. As you remove the assembly, the washers between the bearing and sliding forks will be loose. Do not lose the washers.

Replace Friction Disc

1. Remove three (3) hex bolts and nuts holding friction disc to shift carrier.
2. Remove the old friction disc. Put the new friction disc in place, flat side to the shift carrier.
3. Reinstall the three (3) bolts and nuts into the new friction disc and hub. Torque to 5-6 lbf-ft (6.8 to 8.13 N•m).

Reinstall Friction Disc

1. Reinstall the shift carrier, the small pinion gear and washer onto the hex shaft. The washer goes between the bearing and the pinion gear.
2. Slide the shaft and attached parts into the frame, through the right side hole first, then the left. Pinion gear must mesh with the large gear.
3. Reinstall the bearing and outside bearing cap on the left side of the frame.
4. On the right side of the frame, place the washer on the end of the shaft.
5. Reinstall the bearing cap/bushing on the right side of frame.
6. Reinstall the flange bearing and washers into the shift forks. Be sure the washers are inside the forks.
7. Reinstall roll pins in shaft. Be sure pins are centered in shaft.
8. Reinstall shift rod with hairpin and washer.
9. Reinstall tires with bolts and locknuts.
10. Set unit upright.
11. Replace spark plug wire on spark plug.

FRICION DISC REPLACEMENT (932101, 309)

Remove Friction Disc

(Figure 20):

1. Shut off engine, remove key, disconnect spark plug wire and allow unit to cool completely.



CAUTION: Before tipping unit, remove enough fuel so that no spills occur.

2. Tip the unit up onto front housing on a level surface.
3. Remove lock pins from wheel axles and remove wheels.
4. Remove two (2) bolts from top of bottom cover.
5. Loosen two (2) bottom screws and slide cover off.
6. Remove hair pin and washer from shift rod. Disconnect shift rod from lower speed selector arm. Reinstall hairpin and washer on rod (Figure 13).
7. Remove four (4) nuts from bearing caps on both sides of unit.
8. Remove bearing caps from outside of unit.
9. Reinstall one nut on each bearing cap to keep the inside bearing cap in place.

10. Carefully tap roll pins out of hex shaft.
11. Remove three (3) hex bolts and nuts holding friction disc to shift carrier.
12. Tap hex shaft on left side to loosen from shift carrier.
13. Hold shift carrier and slide the shaft slowly to the right. Be sure to catch spacer inside housing at the left end of the shaft. The shaft slides out of the small sprocket which is held by the chain.
14. Slide shaft only far enough to remove the old friction disc from the shaft.

Replace Friction Disc

1. Put the new friction disc in place, flat side to the shift carrier.
2. Hold the shift carrier and slide the shaft back toward the left, through the small sprocket, through the spacer and through the opening in the side frame.
3. Reinstall bearings, which may have fallen out of bearing caps.
4. Reinstall bearing caps on outside of unit.
5. Install new friction disc onto shift carrier with three (3) hex bolts and nuts. Torque to 5-6 lbf-ft (6.8 to 8.13 N•m).
6. Reinstall roll pins in shaft. Be sure pins are centered in shaft.
7. Reinstall speed selector lever with washer and hairpin.
8. Reinstall bottom cover and hardware.

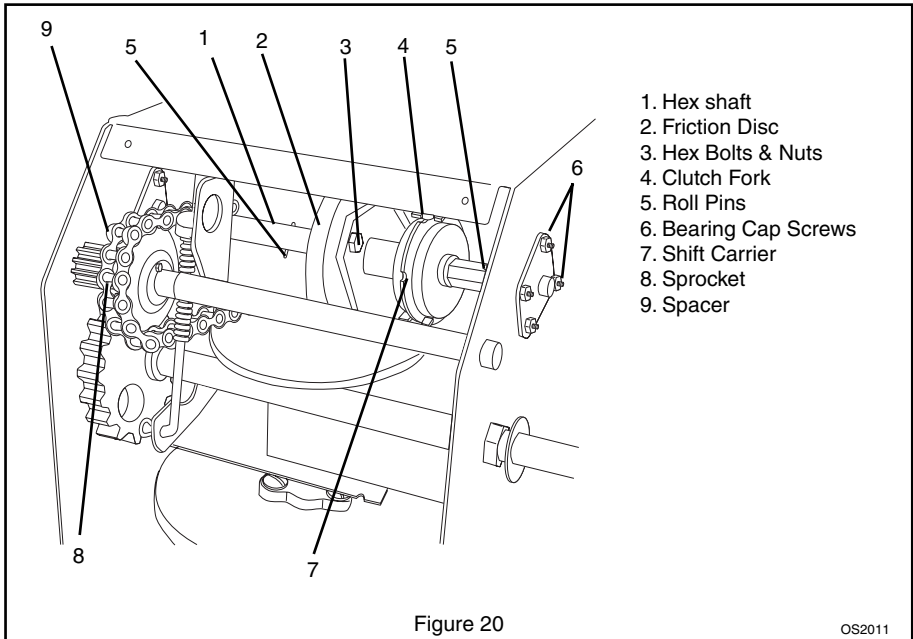

Figure 20

OS2011

- 9. Reinstall tires with clip pins.
- 10. Set unit upright.

- 11. Replace spark plug wire on spark plug.

STORAGE



WARNING: AVOID INJURY. Read and understand *Storage Safety Rules* in *Safety* section before proceeding.

SHORT TERM

IMPORTANT: NEVER spray unit with high pressure water or store unit outdoors.

Run with attachment clutch engaged a few minutes after each use to free unit of any loose or melting snow.

Inspect unit for visible signs of wear, breakage or damage.

Keep all nuts, bolts and screws properly tightened and know unit is in safe working condition.

Store unit in a cool, dry protected area.

LONG TERM

Clean unit thoroughly with mild soap and low pressure water and lubricate (see Maintenance). Touch up all scratched painted surfaces.

Remove weight from wheels by putting blocks under frame or axle.

When storing unit for extended periods of time, remove all fuel from tank and carburetor (run dry). Refer to Engine Manual.

TROUBLESHOOTING

PROBLEM	PROBABLE CAUSE	CORRECTION
Engine will not crank/start.	<ol style="list-style-type: none"> 1. Fuel tank is empty. 2. Build up of dirt and residue around governor/carburetor. 3. Key Switch not in run position. 4. Ignition switch starter circuit not functioning. 	<ol style="list-style-type: none"> 1. Fill fuel tank. 2. Clean area around governor/carburetor. 3. Put Key Switch into run position. 4. Check for a bad starter or connections.
Engine stops.	<ol style="list-style-type: none"> 1. Out of fuel. 2. Mechanical jam in blower rake or impeller. 3. Polluted fuel supply. 4. Faulty spark plug. 	<ol style="list-style-type: none"> 1. Fill fuel tank. 2. Turn off engine, remove key, and wait for all moving parts to stop. Check for and remove obstruction and repair before restart. 3. Replace with clean fuel. 4. Replace or clean spark plug.
Engine problems.	<ol style="list-style-type: none"> 1. See Engine Manual. 	
Does not operate in Forward/Reverse.	<ol style="list-style-type: none"> 1. Friction disc not adjusted properly. 2. Traction belt not functioning. 	<ol style="list-style-type: none"> 1. Repair or replace friction disc. See <i>Service and Adjustments</i>. 2. Repair or replace traction drive belt. See <i>Service and Adjustments</i>.

TROUBLESHOOTING

PROBLEM	PROBABLE CAUSE	CORRECTION
Small rubber beads collect in frame	1. Friction disc wear.	1. Normal friction disc wear. Chunks or large pieces of rubber mean friction disc should be checked and replaced as necessary.
Unit does not throw snow	1. Shear bolts broken. 2. Attachment clutch/brake not adjusted properly. 3. Attachment drive belt worn or damaged.	1. Replace shear bolts (see <i>Shear Bolts</i>). 2. Adjust attachment clutch/brake (see <i>Attachment Clutch/Brake Adjustment</i>). 3. Replace attachment drive belt (see <i>Attachment Clutch/Brake Adjustment</i>).

SERVICE PARTS

Order the following parts through your Dealer:	
Part No.	Description
00036800	Stens Mix Hi-Temp Grease (3, 3 oz. cartridges)
21533500	Spark Plug (932035, 503)
21533400	Spark Plug (932101, 309)
07232500	Impeller Belt (932035, 503)
07234000	Impeller Belt (932101, 309)
07210700	Traction Belt (932035, 503)
07231000	Traction Belt (932101, 309)
53200500	Shear Bolts (932035, 503)
51001500	Shear Bolt Kit (932101, 309)
03240700	Friction Disc

To obtain a complete parts manual, find your model and serial number. Then go to www.ariens.com.

ACCESSORIES

See your authorized Ariens dealer to add the additional accessories available to your Sno-Thro.	
Part No.	Description
73203100	Slicer Bar
72200600	120 Volt Starter Kit (932035, 503)
73202500	240 Volt Starter Kit *(932503)
72403600	120 Volt Starter Kit (932101, 309)
72402200	240 Volt Starter Kit *(932309)
72406500	Front Weight Kit*
72406300	Deflector Remote Control Kit* (932101, 309)

* Available in CE countries.

SPECIFICATIONS

Model Number	932309	932101	932503	932035
Description	824	824	724	724
Engine - Tecumseh	HMSK80-155700W	HMSK80-155699W	OHSK70-72507E	OHSK70-72517E
Power Max - HP (Kw/min ⁻¹)	8 (5.97)		7 (5.22)	
Fast Idle Speed-RPM (min ⁻¹)	3600 ± 150			
Displacement - in. (cc)	19.43 (318.3)		11.88 (195)	
Electric Start	Optional 240V	120V	Optional 120V or 240V	120V
Fuel	See Engine Manual			
Tank Capacity - qt. (L)	4 (3.8)		3.5 (3.3)	
Snow Clearing Width - in. (cm)	24 (61.0)			
Snow Throwing Distance - ft (m)	3-45 (0.9-13.7)		3-35 (0.9-10.7)	
Chute				
Rotation Angle	220°			
Rotation Control at Handlebar	Yes			
Dual Handle Interlock	Yes		N/A	
Impeller				
Diameter - in. (cm)	12 (30.5)		10 (25)	
Speed-RPM-Max (min ⁻¹)	1410			
Auger				
Diameter - in. (cm)	15 (38.1)		12 (30.5)	
Speed-RPM-Max (min ⁻¹)	141			
Auger Brake	Yes			
Drive	Disc-O-Matic			
Speeds	6 Forward and 2 Reverse			
Pneumatic Tires - in. (cm)	15 (38.1)		12 (30.5)	
Size and Weight				
Height - in. (cm)	42 (106.7)		43 (109.2)	
Length - in. (cm)	59.1 (150.2)		52 (132)	
Width - in. (cm)	26.6 (67.6)		26.5 (67.3)	
Weight - lbs (Kg)	240 (108.9)		170 (77.1)	175 (79.4)
Headlight	Yes		N/A	
CE Sound and Vibration				
Oper. Ear Sound Pressure (L _{pa}) in dBA	93	N/A	88	N/A
Vibration Measure @ Operator Hands				
X	3.0	N/A	1.8	N/A
Y	6.9	N/A	5.4	N/A
Z	9.5	N/A	7.7	N/A



Ariens Company
655 West Ryan Street
P.O. Box 157
Brillion, WI 54110-0157
920-756-2141
Fax 920-756-2407
www.ariens.com

3 Year Limited Sno-Thro Warranty

Ariens Company warrants to the original purchaser that consumer products manufactured by Ariens Company will be free from defects in material and workmanship for a period of three (3) years after the date of purchase, and will repair any defect in material or workmanship, and repair or replace any defective part, subject to the conditions, limitations and exclusions set forth herein.

The three year duration of this warranty applies only if the product is put to ordinary, reasonable, and usual personal, family, or household uses. If the product is put to any business, commercial, or industrial use, then the duration of this warranty is ninety (90) days after the date of purchase, or one (1) year after the date of purchase if the product is labeled as a Professional/Commercial Product. If any product is rented or leased, then the duration of this warranty is ninety (90) days after the date of purchase.

Genuine Ariens service parts and accessories not purchased with the product covered by this warranty, but which are later purchased and used with that product, are warranted to be free from defects in material and workmanship for a period of ninety (90) days after date of purchase, and Ariens Company will repair or replace any such part or accessory free of charge, except for labor, during that period.

This warranty is subject to the following conditions, limitations, and exclusions:

This warranty is valid only if the following conditions are met:

- The warranty registration card must be completed and returned to Ariens Company.
- The purchaser must perform maintenance and minor adjustments explained in the owner's manual.
- The purchaser must promptly notify Ariens Company or an authorized Ariens service representative of the need for warranty service.

The following items are not covered by this warranty:

- Engines and engine accessories are covered only by the warranty made by the engine manufacturer, and are not covered by this warranty.
- Parts that are not genuine Ariens service parts are not covered by this warranty.
- Shoes, runners, scraper blades, shear bolts, headlights, light bulbs, are not covered by this warranty.
- Any defect which is the result of misuse, alteration, improper assembly, improper adjustment, neglect, or accident, is not covered by this warranty.
- Products which were not purchased in the United States, Puerto Rico, or Canada are not covered by this warranty. In all other countries, contact place of purchase.

This warranty is subject to the following limitations:

- The purchaser must transport the product to and from the place of warranty service.
- Warranty service must be performed by an authorized Ariens service representative. (To find an authorized Ariens service representative, contact Ariens Company at the number or address above.)
- Batteries are warranted only for a period of twelve (12) months after date of purchase, on a prorated basis. For the first ninety (90) days of the warranty period, a defective battery will be replaced free of charge. If the applicable warranty period is more than 90 days, Ariens Company will cover the prorated cost of any defective battery, for up to twelve (12) months after the date of purchase.
- Normal maintenance items including, but not limited to, belts, idlers, cables, friction wheels, tires, wheels, electrical components are warranted for a two year period from the date of purchase unless a shorter period would apply based on how the product is used, then the shorter period will apply.

DISCLAIMER OF FURTHER WARRANTY

Ariens Company makes no warranty, express or implied, other than what is expressly made in this warranty. If the law of your state provides that an implied warranty of merchantability, or an implied warranty of fitness for particular purpose, or any other implied warranty, applies to Ariens Company, then any such implied warranty is limited to the duration of this warranty. Some states do not allow limitations on how long an implied warranty lasts, so the above limitation may not apply to you.

LIMITATION OF REMEDY AND DAMAGES

Ariens Company's liability under this warranty, and under any implied warranty that may exist, is limited to repair of any defect in workmanship, and repair or replacement of any defective part. Ariens Company shall not be liable for incidental, special, or consequential damages (including lost profits). Some states do not allow the exclusion of incidental or consequential damages, so the above limitation or exclusion may not apply to you.

This warranty gives you specific legal rights, and you may also have other rights which vary from state to state.

Form: ALW3-042301



Ariens Company
655 West Ryan Street
P.O. Box 157
Brillion, WI 54110-0157
920-756-2141
Fax 920-756-2407
www.ariens.com

Free Manuals Download Website

<http://myh66.com>

<http://usermanuals.us>

<http://www.somanuals.com>

<http://www.4manuals.cc>

<http://www.manual-lib.com>

<http://www.404manual.com>

<http://www.luxmanual.com>

<http://aubethermostatmanual.com>

Golf course search by state

<http://golfingnear.com>

Email search by domain

<http://emailbydomain.com>

Auto manuals search

<http://auto.somanuals.com>

TV manuals search

<http://tv.somanuals.com>