

# **BLACK & DECKER**®

## **Powerful Solutions**™

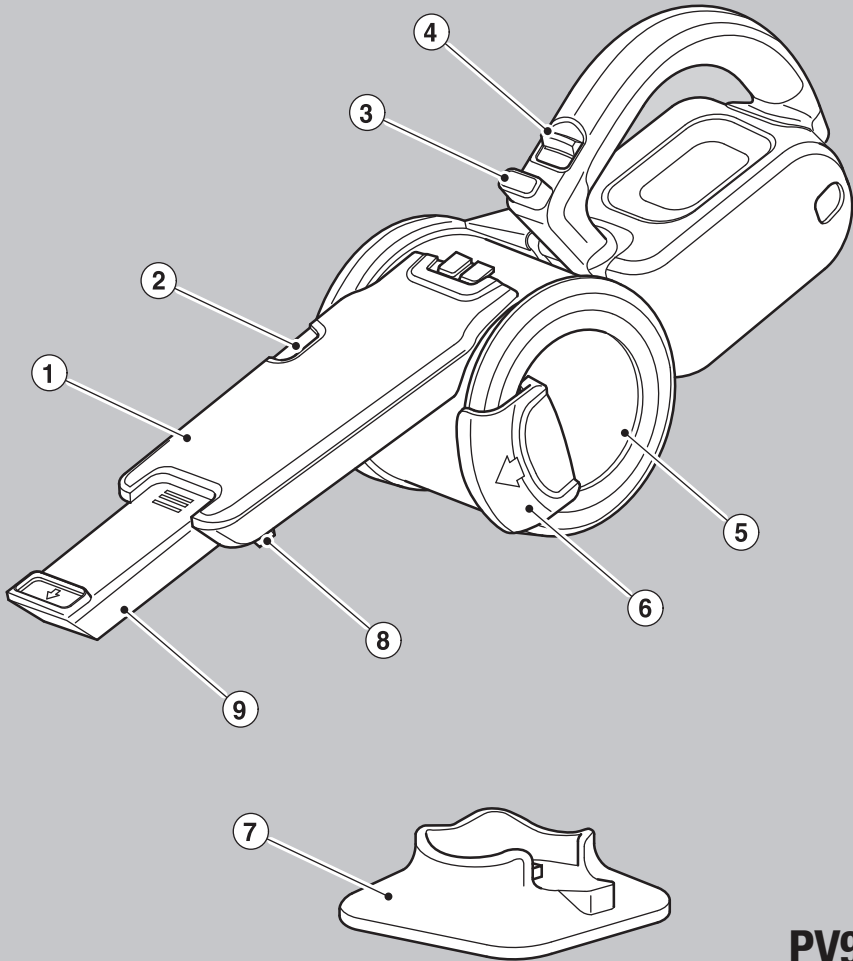

**PV9610**  
**PV1210**  
**PV1410**  
**PV1810**

[www.blackanddecker.com.au](http://www.blackanddecker.com.au)

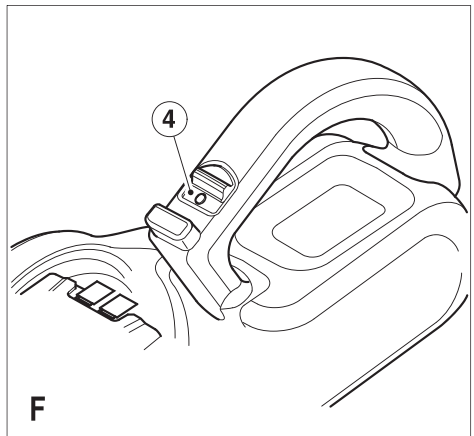
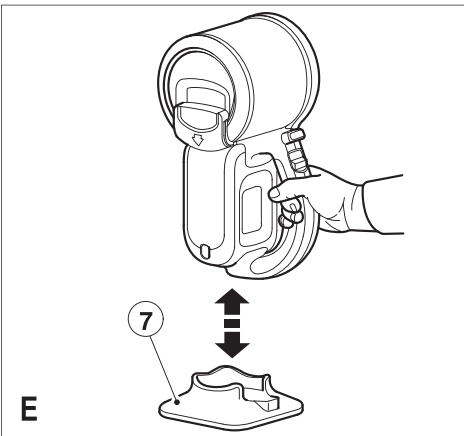
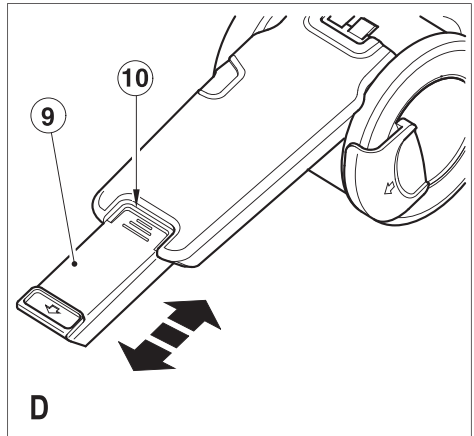
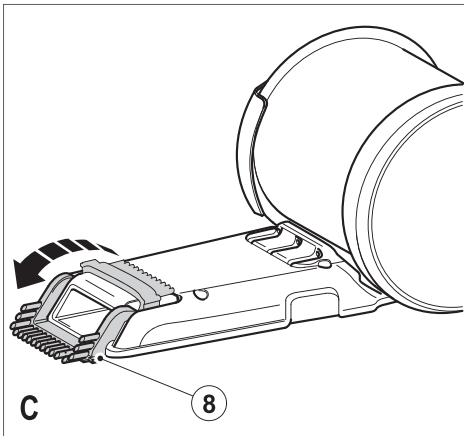
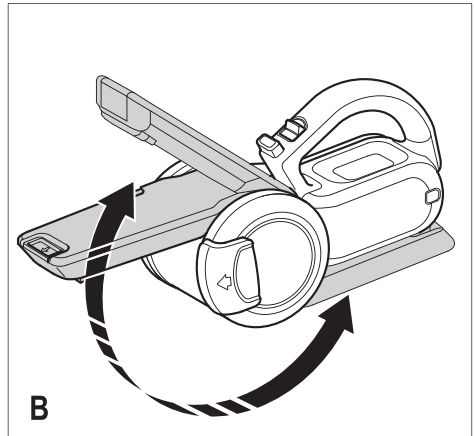
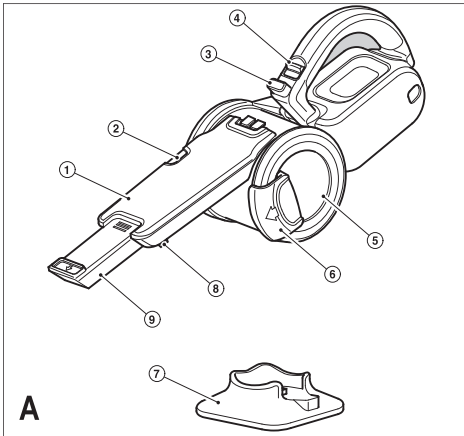

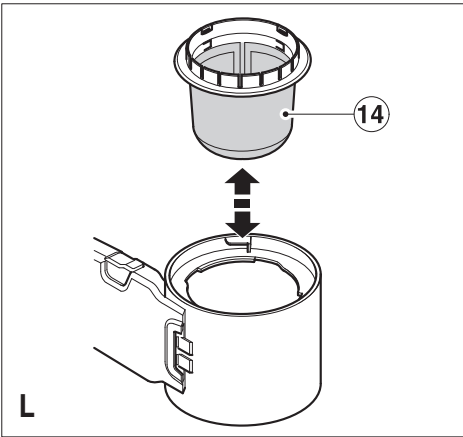
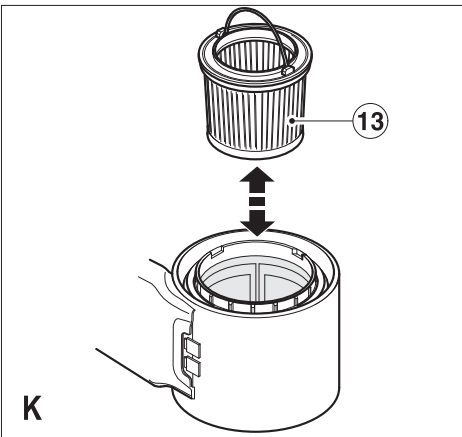
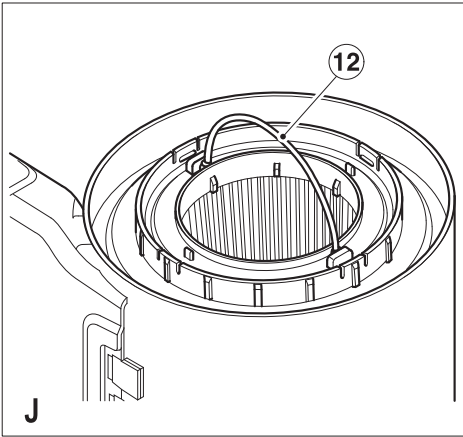
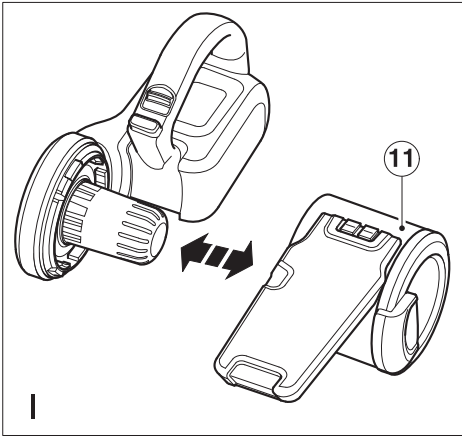
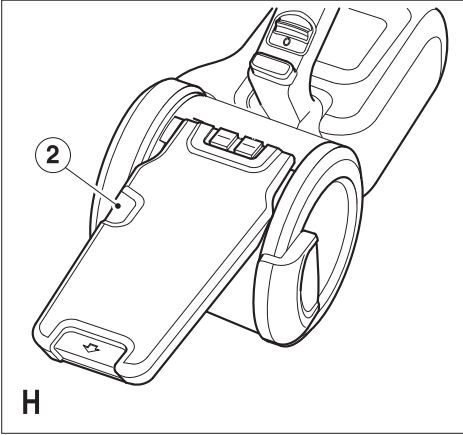
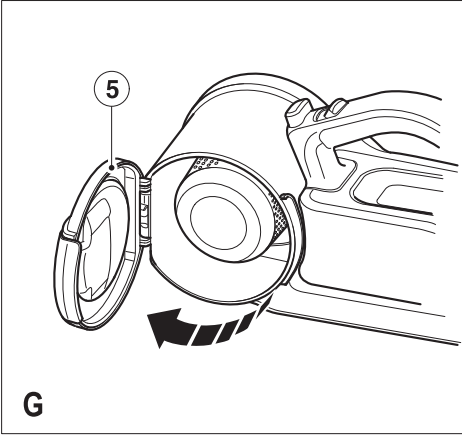

## PV9610/PV1210/PV1410/PV1810 HAND HELD VACUUM

### TECHNICAL DATA

|         |    | PV9610 | PV1210 |
|---------|----|--------|--------|
| Voltage | V  | 9.6    | 12     |
| Weight  | kg | 1.52   | 1.58   |

|         |    | PV1410 | PV1810 |
|---------|----|--------|--------|
| Voltage | V  | 14.4   | 18     |
| Weight  | kg | 1.66   | 1.76   |

| Charger               |      | CHA002014S |
|-----------------------|------|------------|
| Input Voltage         | Vac  | 100-240    |
| Output Voltage        | Vdc  | 7.2-2.4    |
| Output Current        | mA   | 85         |
| Approx. Charging Time | Hour | 21         |
| Weight                | kg   | 0.18       |

### INTENDED USE

Your Black & Decker Dustbuster<sup>®</sup> hand held vacuum cleaner has been designed for light dry vacuum cleaning purposes. This appliance is intended for household use only.

### GENERAL SAFETY RULES

**⚠ Warning!** When using mains-powered/cordless appliances, basic safety precautions, including the following, should always be followed to reduce the risk of fire, electric shock, personal injury and material damage.

- Read all of this manual carefully before using the appliance.
- The intended use is described in this manual. The use of any accessory or attachment or the performance of any operation with this appliance other than those recommended in this instruction manual may present a risk of personal injury.

The term "appliance" in the warnings refers to your mains-operated (corded) appliance or battery-operated (cordless) appliance.

### SAVE ALL WARNINGS AND INSTRUCTIONS FOR FUTURE REFERENCE.

#### 1. Work area safety

- Keep work area clean and well lit.** Cluttered or dark areas invite accidents.
- Only use the appliance in daylight or good artificial light.
- Do not operate your appliance in explosive atmospheres, such as in the presence of flammable liquids, gases or dust.
- Never allow children or people unfamiliar with the

instructions to use the appliance.

- Do not allow children or animals to come near the work area or touch the appliance supply cord.
- Keep children, bystanders and animals away while operating an appliance. Distractions can cause you to lose control.
- The appliance is not to be used as a toy.
- Do not immerse the appliance in water.
- Do not open body casing. There are no user-serviceable parts inside.

#### 2. Electrical safety

- Appliance plugs must match the outlet. Never modify the plug in any way.** Do not use any adapter plugs with earthed (grounded) power tools. Unmodified plugs and matching outlets will reduce risk of electric shock.
- Avoid body contact with earthed or grounded surfaces, such as pipes, radiators, ranges and refrigerators.** There is an increased risk of electric shock if your body is earthed or grounded.
- Do not expose appliance to rain or wet conditions.** Water entering a power tool will increase the risk of electric shock.
- Do not abuse the cord. Never use the cord for carrying, pulling or unplugging the appliance. Keep cord away from heat, oil, sharp edges or moving parts.** Damaged or entangled cords increase the risk of electric shock.
- When operating an appliance outdoors, use an extension cord suitable for outdoor use.** Use of a cord suitable for outdoor use reduces the risk of electric shock.
- If operating a power tool in a damp location is unavoidable, use a residual current device (RCD) protected supply.** Use of an RCD reduces the risk of electric shock.

#### 3. Personal safety

- Stay alert, watch what you are doing and use common sense when operating a power tool. Do not use a power tool while you are tired or under the influence of drugs, alcohol or medication.** A moment of inattention while operating power tools may result in serious personal injury.
- Use personal protective equipment. Always wear eye protection.** Protective equipment such as dust mask, non-skid safety shoes, hard hat, or hearing protection used for appropriate conditions will reduce personal injuries.
- Prevent unintentional starting. Ensure the switch is in the off-position before connecting to power source and/or battery pack, picking up or carrying the tool.** Carrying power tools with your finger on the switch or energising power tools that have the switch on invites accidents.

- b. Remove any adjusting key or wrench before turning the power tool on.** A wrench or a key left attached to a rotating part of the power tool may result in personal injury.
- c. Do not overreach. Keep proper footing and balance at all times.** This enables better control of the power tool in unexpected situations.
- d. Dress properly. Do not wear loose clothing or jewellery. Keep your hair, clothing and gloves away from moving parts.** Loose clothes, jewellery or long hair can be caught in moving parts.
- e. If devices are provided for the connection of dust extraction and collection facilities, ensure these are connected and properly used.** Use of dust collection can reduce dust-related hazards.

#### 4. Appliance use and care

- a. Before use, check the appliance for damaged or defective parts.** Check for breakage of parts, damage to switches and any other conditions that may affect its operation.
- b. Do not use the appliance if the switch does not turn it on and off.** Any appliance that cannot be controlled with the switch is dangerous and must be repaired.
- c. Disconnect the plug from the power source and/or the battery pack from the appliance before making any adjustments, changing accessories, or storing appliances.** Such preventive safety measures reduce the risk of starting the appliance accidentally.
- d. Where applicable, keep cutting tools sharp and clean.** Properly maintained cutting tools with sharp cutting edges are less likely to bind and are easier to control.
- e. Do not use the appliance if any part is damaged or defective.**
- f. Have any damaged or defective parts repaired or replaced by an authorised repair agent.**
- g. Never attempt to remove or replace any parts other than those specified in this manual.**

#### 5. Battery tool use and care

- a. Ensure the switch is in the off position before inserting battery pack.** Inserting the battery pack into appliance that have the switch on invites accidents.
- b. Recharge only with the charger specified by the manufacturer.** A charger that is suitable for one type of battery pack may create a risk of fire when used with another battery pack.
- c. Use appliance only with specifically designated battery packs.** Use of any other battery packs may create a risk of injury and fire.
- d. When battery pack is not in use, keep it away from other metal objects like paper clips, coins, keys, nails, screws, or other small metal objects that can make a connection from**

**one terminal to another.** Shorting the battery terminals together may cause burns or a fire.

- e. Under abusive conditions, liquid may be ejected from the battery; avoid contact. If contact accidentally occurs, flush with water. If liquid contacts eyes, additionally seek medical help.** Liquid ejected from the battery may cause irritation or burns.

#### After use

- When not in use, the appliance should be stored in a dry, well ventilated place out of the reach of children.
- Children should not have access to stored appliances.
- When the appliance is stored or transported in a vehicle it should be placed in the boot or restrained to prevent movement following sudden changes in speed or direction.

#### Safety of others

- This appliance is not intended for use by persons (including children) with reduced physical, sensory or mental capabilities, or lack of experience and knowledge, unless they have been given supervision or instruction concerning the use of the appliance by a person responsible for their safety.
- Children should be supervised to ensure that they do not play with the appliance.

#### 6. Service

- a. Have your appliance serviced by a qualified repair person using only identical replacement parts.** This will ensure that the safety of the power tool is maintained.

## ADDITIONAL SAFETY INSTRUCTIONS FOR BATTERIES AND CHARGERS

#### Batteries

- Never attempt to open for any reason.
- Do not expose the battery to water.
- Do not expose the battery to heat.
- Do not store in locations where the temperature may exceed 40°C. Charge only at ambient temperatures between 10°C and 40°C.
- Charge only using the charger provided with the appliance/tool. Using the wrong charger could result in an electric shock or overheating of the battery.
- When disposing of batteries, follow the instructions given in the section "Protecting the environment".
- Do not damage/deform the battery pack either by puncture or impact, as this may create a risk of injury and fire.
- Do not charge damaged batteries.
- Under extreme conditions, battery leakage may occur. When you notice liquid on the batteries carefully wipe the liquid off using a cloth. Avoid skin contact.

- In case of skin or eye contact, follow the instructions below.

**Warning!** The battery fluid may cause personal injury or damage to property. In case of skin contact, immediately rinse with water. If redness, pain or irritation occurs seek medical attention. In case of eye contact, rinse immediately with clean water and seek medical attention.

### Chargers

Your charger has been designed for a specific voltage. Always check that the mains voltage corresponds to the voltage on the rating plate.

**Warning!** Never attempt to replace the charger unit with a regular mains plug.

- Use your Black & Decker charger only to charge the battery in the appliance/tool with which it was supplied. Other batteries could burst, causing personal injury and damage.
- Never attempt to charge non-rechargeable batteries.
- If the supply cord is damaged, it must be replaced by the manufacturer or an authorised Black & Decker Service Centre in order to avoid a hazard.
- Do not expose the charger to water.
- Do not open the charger.
- Do not probe the charger.

The appliance/tool/battery must be placed in a well ventilated area when charging.

## SYMBOLS ON THE CHARGER

The following symbols are found on your charger:

 Your charging base is double insulated; therefore no earth wire is required. Always check that the power supply corresponds to the voltage on the rating plate.

 Safety isolating transformer. The mains supply is electrically separated from the transformer output.

 The charging base is intended for indoor use only.

## Using an Extension Cable

An extension cable should not be used unless absolutely necessary. Use of an improper extension cable could result in a risk of fire and electric shock. If an extension cable must be used, use only those that are approved by the country's Electrical Authority. Make sure that extension cord is in good condition before using. Always use the cord that is suitable for the power input of your tool (see technical data on name plate). The minimum conductor size is 1 mm<sup>2</sup>; the maximum length is 30m. When using a cable reel, always unwind the cable completely.

## FEATURES (FIG. A)

1. Dust collector

2. Dust container release button
3. Pivot lock button
4. On/off switch
5. Container door
6. Container door release latch
7. Charging base
8. Flip-out brush
9. Dust collector extension

## ASSEMBLY AND ADJUSTMENT

### Adjusting the dust collector (fig. B-D)

- The dust collector (1) has a brush that can be folded forward for dusting and upholstery cleaning. The dust collector (1) is stored under the appliance. To adjust for use, lift the appliance from the charging base (7).
- Press the pivot lock button (3) and rotate the dust collector (1) to the required position.
- Release the pivot lock button (3) to lock the dust collector in position.
- The dust collector can be extended by pulling the dust collector extension (9) until it locks into position.
- The extension can be retracted by pressing the button (10) and pushing the extension back into the dust collector.
- The dust collector should be returned to the storage position under the appliance after use and while charging the appliance.

## USE

- Before first use, the battery must be charged for at least 24 hours.
- Place the appliance on the charging base whenever it is not in use.

### Charging the battery (fig. E)

- Make sure that the appliance is switched off. The battery will not be charged with the on position.
- Place the appliance on the charging base (7) as shown.
- Plug in the charger. Switch on at the mains.

The charging indicator will be lit.

- Leave the appliance to charge for at least 24 hours. While charging, the charger may become warm. This is normal and does not indicate a problem. The appliance can be left connected to the charger indefinitely. The charging indicator will be lit as long as the appliance is connected to the plugged-in charger.

**Warning!** Do not charge the battery at ambient temperatures below 4°C or above 40°C.

### Switching on and off (fig. F)

- To switch the appliance on, slide the on/off switch (4) forward to position "I".
- To switch the appliance off, slide the on/off switch (4) back to position "0".

### Optimising the suction force (fig. H - J)

In order to keep the suction force optimised, the filters must be cleared regularly during use.

- Press the release latch (6) and open the container door(5) (fig. G).
- Empty the dust container.

## MAINTENANCE

Your Black & Decker appliance has been designed to operate over a long period of time with a minimum of maintenance.

Continuous satisfactory operation depends upon proper care and regular cleaning.

- Regularly clean the ventilation slots in your appliance using a soft brush or dry cloth.
- Regularly clean the motor housing using a damp cloth. Do not use any abrasive or solvent-based cleaner. Never let any liquid get inside the tool and never immerse any part of the appliance into liquid.

### Cleaning

Rotating the bowl (fig. B) agitates the filter to remove dirt. It is important however to empty the bowl regularly by removing the filters (fig. K).

**Warning!** Regularly clean the filters (12 & 13).

### Cleaning the dust container and filters (fig. H - L)

There are two methods of cleaning the bowl, a quick empty method and a thorough clean method. To carry out the quick empty method use the following instructions.

The filters are re-usable and should be cleaned regularly.

- Press the release latch (6) and open the container door(5) (fig. G).
- Empty the dust container (11).
- Close the dust container door (5). Make sure that the release latch (6) clicks into place.

To carry out a thorough clean of the bowl, use the following instructions.

The dust container (11) is attached to the body of the appliance with a bayonet fixing, to remove the dust container:

- Press the dust container release button (2) and rotate the dust container (11) anti-clockwise and carefully slide the dust container clear of the appliance.
- Rotate the filter hook (12) to the vertical position (fig.J).
- Use the filter hook (12) to rotate the filter (13) within the pre-filter (14) to agitate it and remove dirt.
- Remove the main filter (13).
- Brush any loose dust off the filter (13).

The pre-filter (14) is attached with a bayonet fixing, to remove the pre-filter:

- Rotate the pre-filter (14) anti-clockwise and carefully slide the it clear of the dust container.
- Install the pre- filter (14) in to the dust container (11)

rotating it clockwise until it locks into place.

- Install the main filter (13) in to the pre-filter (14).
- Install the dust container (11) to the appliance, rotate it clockwise until it locks into place.

**Warning!** Never use the appliance without the filters.

Optimum dust collection will only be achieved with clean filters.

### Replacing the filters

The filters should be replaced every 6 to 9 months and whenever worn or damaged. Replacement filters are available from your Black & Decker dealer (cat. no. VF90):

- Remove the old filters as described above.
- Fit the new filters as described above.

### Important

To ensure product SAFETY and RELIABILITY, repairs, maintenance and adjustment (other than those listed in this manual) should be performed by authorized service centers or other qualified organizations, always-using identical replacement parts. Unit contains no user serviceable parts inside.

## PROTECTING THE ENVIRONMENT



Separate collection. This product must not be disposed of with normal household waste.

Should you find one day that your Black&Decker product needs replacement, or if it is of no further use to you, do not dispose of it with household waste. Make this product available for separate collection.



Separate collection of used products and packaging allows materials to be recycled and used again.

Re-use of recycled materials helps prevent environmental pollution and reduces the demand for raw materials. If necessary, contact your local municipality for proper disposal instructions in your city/town.

### Batteries

Black&Decker batteries can be recharged many times. At the end of their useful life, discard batteries with due care for our environment:

Run the battery down completely, and then remove it from the tool.

NiCd and NiMH batteries are recyclable. Take them to a local recycling station.

### NOTE

Local regulations may provide for separate collection of electrical products from the household, at municipal waste sites or by the retailer when you purchase a new product. Black&Decker provides a facility for the collection and recycling of Black&Decker products once they have reached the end of their working life. To take



advantage of this service please return your product to any authorised repair agent who will collect them on our behalf. You can check the location of your nearest authorised repair agent by contacting your local Black&Decker office at the address indicated in this manual. Alternatively, a list of authorised Black&Decker repair agents and full details of our after-sales service and contacts are available on the Internet at [www.2helpU.com.au](http://www.2helpU.com.au)

## GUARANTEE

Black & Decker is confident of the quality of its products and offers an outstanding guarantee. This guarantee statement is in addition to and in no way prejudices your statutory rights. The guarantee is valid within the territories of the Member States of the European Union and the European Free Trade Area.

If a Black & Decker product becomes defective due to faulty materials, workmanship or lack of conformity, within 24 months from the date of purchase, Black & Decker guarantees to replace defective parts, repair products subjected to fair wear and tear or replace such products to make sure of the minimum inconvenience to the customer unless:

- The product has been used for trade, professional or hire purposes.
- The product has been subjected to misuse or neglect.
- The product has sustained damage through foreign objects, substances or accidents.
- Repairs have been attempted by persons other than authorised repair agents or Black & Decker service staff.

To claim on the guarantee, you will need to submit proof of purchase to the seller or an authorised repair agent. You can check the location of your nearest authorised repair agent by contacting your local Black & Decker office at the address indicated in this manual.

Alternatively, a list of authorised Black & Decker repair agents and full details of our after-sales service and contacts are available on the Internet at: [www.2helpU.com](http://www.2helpU.com)

Please visit our website [www.blackanddecker.com.au](http://www.blackanddecker.com.au) to register your new Black & Decker product and to be kept up to date on new products and special offers. Further information on the Black & Decker brand and our range of products is available at [www.blackanddecker.com.au](http://www.blackanddecker.com.au)

Contact information:

Australia  
Black & Decker (Australia) Pty. Ltd Tel. 03-8720 5100  
20 Fletcher Road, Mooroolbark, Fax. 03-9727 5940  
Victoria, 3138

New Zealand  
Black & Decker Tel. 0800 339 258  
5 Te Apunga Place Fax. +64 9 259 1122  
Mt Wellington  
Auckland 1060

Contact your local council for disposal information.



## Free Manuals Download Website

<http://myh66.com>

<http://usermanuals.us>

<http://www.somanuals.com>

<http://www.4manuals.cc>

<http://www.manual-lib.com>

<http://www.404manual.com>

<http://www.luxmanual.com>

<http://aubethermostatmanual.com>

Golf course search by state

<http://golfingnear.com>

Email search by domain

<http://emailbydomain.com>

Auto manuals search

<http://auto.somanuals.com>

TV manuals search

<http://tv.somanuals.com>