



19" Hover Mower

OPERATOR'S MANUAL

POWERED by
HONDA™



Models
RC190-GCV160
RC190-BS550



HOVER MOWER OPERATOR'S MANUAL

Introduction

Read this information carefully to learn how to operate and maintain your product properly and to avoid injury and product damage. You are responsible for operating the product properly and safely.

Important: This engine is not equipped with a spark arrester muffler. It is a violation of California Public Resource Code Section 4442 to use or operate the engine on any forest-covered, brush-covered, or grass-covered land. Other states or federal areas may have similar laws. This spark ignition system complies with Canadian ICES-002.

The enclosed Engine Owner's Manual is supplied for information regarding the US Environmental Protection Agency (EPA) and the California Emission Control Regulation of emission systems, maintenance, and warranty. Replacements may be ordered through the engine manufacturer.

You may contact California Trimmer directly for product and accessory information, help finding a dealer, or to register your product. Whenever you need service, genuine California Trimmer parts, or additional information, please contact an Authorized Service Dealer or Customer Service and have the model and serial numbers of your product ready. They are located on the decal on the rear of the unit as shown below:



Write the numbers in the following space provided.

Model Number: _____

Serial Number: _____

You may complete and mail the enclosed product registration card or you can register on-line at:

<http://caltrimmer.com>

<http://engines.honda.com>

www.briggsandstratton.com

Should you require warranty service, take a copy of your sales receipt and a copy of your product registration card to your servicing dealer.

Carton Contents

- California Trimmer Hover Mower
- California Trimmer Product Registration Card
- Engine Owner's Manual / Emission System Warranty
- Lower Handle Assembly (with handle stand)
- Upper Handle Assembly (including throttle control for Honda engine only, engine stop lever and adjustment)
- Handle bolts, washers and knobs

Assembly & Set-up

The unit has been carefully assembled with adjustments and quality inspections performed by a team of trained factory technicians who take great pride in their work. To facilitate packaging and shipment, there are components that need to be installed.

Note: It is recommended that this unit be set up and checked by an Authorized Dealer.

Tools Required

- Regular or needle-nose pliers.
- 9/16" wrench and 1/2" wrench (for adjusting cutting height and replacing blades – see page 7)

1. Insert the lower handle section into the mounting brackets on each side of the deck...NOTE: the handle stand lever will be on the LEFT side for the Honda engine / RIGHT side for the B&S engine.

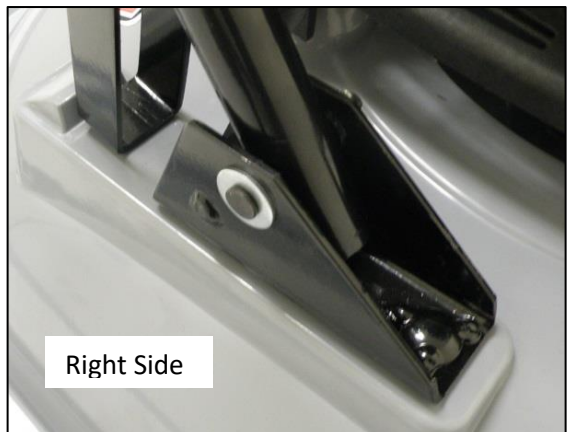

Assembly & Set-up (continued)

2. Attach the handle inserting the pins on each side and install the cotter pins with the washer placed beneath, then bend as shown to secure in place.

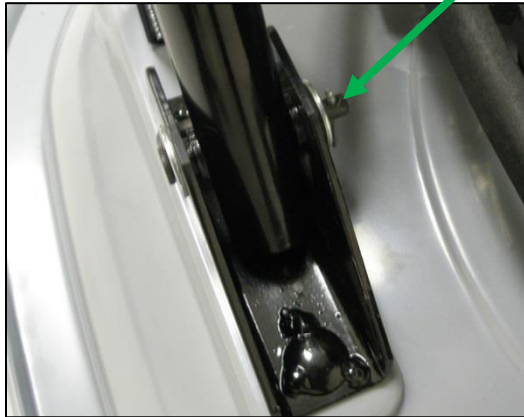

3. Attach the upper handle section to the lower handle section using the bolts and knobs. Fasten the corrugated tubing (which covers the throttle and engine stop cables) to the handles using the tie straps included.

NOTE: the throttle control for the Honda engine and stop lever cable adjuster must be on the **right side** from the operator position. The stop lever adjuster for the Briggs engine is to be installed on the **left side**.



4. Verify that the engine stop lever is installed (with cable connected) and it pivots upward completely against the handle.

Key Components

The image below identifies key components of the California Trimmer Hover Mower so take the time to familiarize yourself with them and their function.





HOVER MOWER OPERATOR'S MANUAL

Safety Instructions

The following safety alert symbols are use in these instructions in conjunction with important safety messages related to the operation of the unit and potential hazards. As you familiarize yourself with the various features and functionality of this mower, please take note of the subjects and specific instructions that include these images...

⚠ DANGER

...WILL cause serious or fatal injury if the instructions are not followed.

⚠ WARNING

...CAN cause serious or fatal injury if the instructions are not followed.

Safety Labels

On the unit itself, there are additional labels that identify important safety issues. The following one refers to the hazards of the cutting blades.



The following label identifies important instructions related to the operation of the mower:



Safety Precautions & Training

⚠ WARNING

Understand the operation of all controls and learn how to stop the engine and mower quickly in case of emergency. Make sure the operator receives adequate instruction before operating this unit. When instructions refer to the left or right side of the unit, it means as standing at the normal operation position.

1. Read all information contained in this manual and the engine manual carefully. Be thoroughly familiar with the controls and proper use of the equipment.
2. Never allow children to operate mower.
3. Never try to mow across excessively steep terrain.
4. Keep area of operation clear of all persons, particularly small children and pets.
5. Never operate the mower without proper guards / shields or handles in place.
6. Thoroughly train anyone using the mower. Make sure all mower operators know the safety, operating and maintenance procedures.
7. Never leave the mower unattended with the engine running.
8. Mow only in daylight or in good artificial light.
9. Always be sure of your footing. Keep a firm hold on the handle and walk, don't run.
10. Do not operate mower when barefoot or wearing open sandals. Always wear substantial foot wear, and pants or slacks that cover your legs when operating mower.
11. Do not operate over gravel surfaces.
12. Do not tip the unit backwards or on its side with fuel in the tank.

Preparation & Inspection

⚠ WARNING

1. Thoroughly inspect the area where mower is to be used, and remove all stones, sticks, wire, bones and other foreign objects which might be picked up and thrown.
2. Check fuel before starting engine. Do not fill gasoline tank indoors, or when engine is running. Wait until engine has been allowed to cool for several minutes. Clean off any spilled gasoline before starting engine.
3. Make the unit is on a flat level surface before starting engine.
4. Do not use mower unless all guards are properly in place.
5. Inspect the unit to verify the controls, safety switches and handles are assembled properly. Do not operate unless they are functioning properly.
6. Never raise the deck with the engine running.
7. If the machine should start to vibrate abnormally, stop the engine and check for the cause immediately. Vibration is generally a warning of trouble.

Preparation & Inspection (continued)

8. Use care when loading or unloading the machine into a trailer or truck.
9. Never operate machine in a closed area.
10. Keep all nuts and bolts tight to be sure the equipment is in safe working condition.
11. Never tamper with safety devices. Check their proper operation regularly.
12. Keep machine free of grass, leaves, or other debris build-up. Clean up oil or fuel spillage and remove any fuel-soaked debris. Allow machine to cool before storing in an enclosed space.
13. Never make any adjustments or repairs with the engine running. Disconnect the spark plug wire and ground against engine to prevent unintended starting.
14. Do not change the engine governor setting or over-speed the engine.
15. Maintain or replace safety and instruction labels, as necessary.
16. If gasoline is spilled, do not attempt to start the engine but move the machine away from the area of spillage and avoid creating any source of ignition until the gasoline vapor has dissipated.
17. Before using, always visually inspect to see that the blade, bolts and spacers are not worn or damaged. Replace a worn or damaged blade.
18. Stop the engine if the machine has to be tilted for transportation when crossing surfaces other than grass, and when transporting the machine to and from the area to be mowed.

Engine Operation

Review the complete operation and safety instructions provided in the owner's manual of the respective engine manufacturer – which is included in the information packet of this unit.

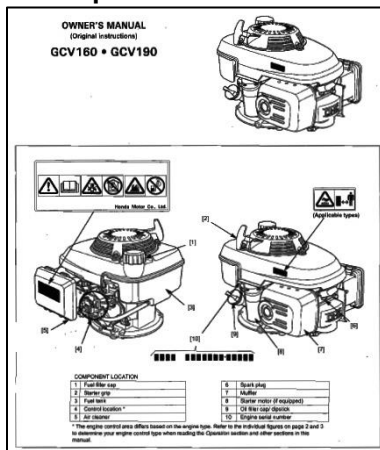

Any service, warranty or replacement parts issues for the engine should be directed to Authorized Service Dealers of the respective engine manufacturer.

Operating Controls

⚠ WARNING

Make sure the handle sections are properly tightened and in the upright position before starting engine.

1. Engine Stop Lever

This stops the engine and the rotation of the cutting blades.



⚠ WARNING

Do not operate the unit if the engine stop lever is damaged or not functioning correctly.

1. Engine Stop Lever – Adjustment

If necessary, the tension of the cable can be changed using the adjuster mount. See mower operation for more information.

Honda Engine

Briggs & Stratton Engine



2. Throttle Control (Honda engine)

This controls the engine speed and ultimately the unit's cutting and hovering. It also activates the engine's choke mechanism for starting - when positioned as shown.

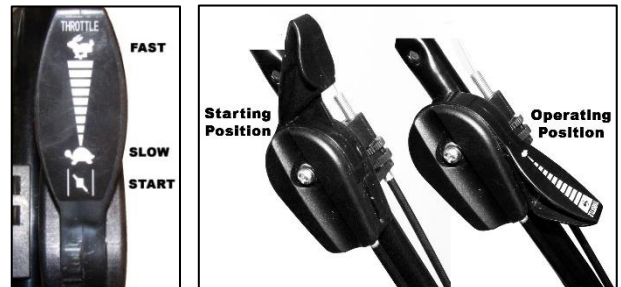



HOVER MOWER OPERATOR'S MANUAL

NOTE: The Briggs & Stratton engine utilizes an automatic throttle control and choke (starting) system so there is no throttle lever.

NOTE: The throttle control does not stop the engine; it is done by releasing the engine stop lever.

Mower Operation

⚠ WARNING

Make sure the ground is flat and clear of debris and do not attempt to start on a sloped / inclined surface.

Make sure the fuel tank cap is properly installed and tightened.

1. Starting

- a. (Honda engine)
Move the fuel valve to the ON (open) position

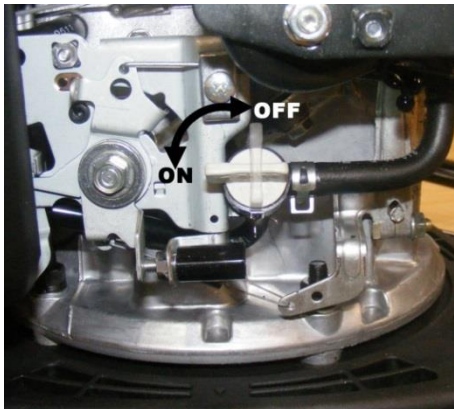

⚠ WARNING

Keep the fuel valve in the OFF position when the unit is transported or not in use for an extended period.

- b. (Honda engine)
Move the throttle control back to the start position.
- c. Pivot the engine stop lever against the handle and grasp with your left hand.



- d. Place your foot on the side of the deck to hold the unit while pulling the recoil starter.



After the engine has started, carefully move behind the unit while continuing to grip the engine stop lever against the handle and adjusting your grip using both hands.

⚠ WARNING

Always maintain a firm grip on the handle and engine stop lever and keep the unit in front of you. If mower should start to vibrate abnormally, stop the engine and check for the cause. Vibration is generally a sign of trouble.

2. Mowing

⚠ DANGER

Always use both hands when operating the unit. Slopes are a major factor related to slip and fall accidents, which can result in severe injury. Operation on all slopes requires extra caution. Never operate the mower on a slope at an angle above your position. If you feel uneasy on a slope, do not mow it.

- Mow across the face of slopes; never up and down. Exercise extreme caution when changing direction on slopes.
- Watch for holes, ruts, bumps, rocks, or other hidden objects. Uneven terrain could cause a slip and fall accident. Tall grass can hide obstacles.
- Do not mow on wet grass or excessively steep slopes. Poor footing could cause a slip and fall accident.
- Do not mow near drop-offs, ditches, or embankments. You could lose your footing or balance.



HOVER MOWER OPERATOR'S MANUAL

Mower Operation (continued)

- When cutting steeper inclines from the top of the slope and a longer reach is needed, never tie a rope to the unit. Use the extended handlebar kit #4012561.



If striking a foreign object, stop the engine, remove wire from spark plug, thoroughly inspect mower for damage. Repair damage before restarting engine. Watch out for traffic when working near roadways.

For best performance, install new blades before the cutting season begins. Replace the blades when necessary with California Trimmer replacement blades.

⚠ WARNING

Release the engine stop lever and allow the engine to cool before making inspections or adjustments, and when transporting.

If the engine does not stop, turn the fuel valve to the OFF position and move the throttle lever to the starting (choke) position. Have the unit immediately inspected by an Authorized Service Dealer.

3. Cutting Height Adjustment

The unit's cutting height is adjusted by moving the spacers on either side of the tri-blade assembly (the triangular shaped component that holds the flail blades) or the bar blade.

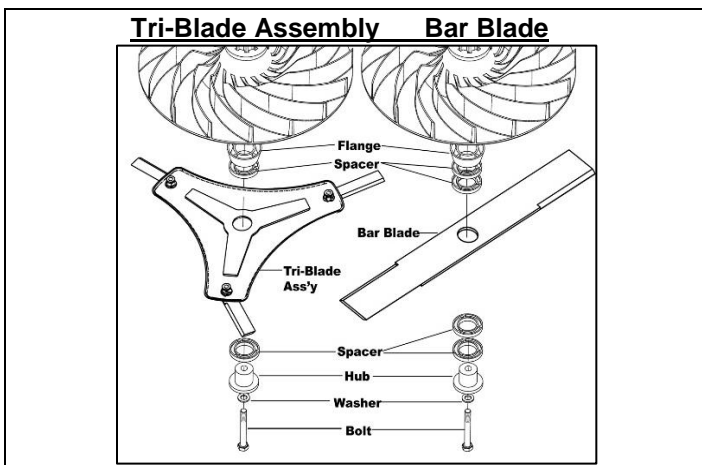

Loosen and remove the center bolt to disassemble the components. Placing all the spacers ABOVE the tri-blade assembly / bar blade will provide the lowest cutting height, while placing all the spacers below will provide the highest cutting height.

IMPORTANT!

Always install the tri-blade assembly with flail blade mounting nuts facing upward (toward impeller / engine). The mounting components; hub, spacers, tri-blade assembly / bar blade and flange, must be installed, aligned and seated properly before tightening the bolt.

4. Additional Cutting Height

Optional kit # HR190 is available for achieving an extra 1.9" (48mm) of cutting height.



5. Transporting

Optional wheel kit # 4041500 is available for quick and easy transporting.



Mower Maintenance

The following maintenance topics are general practices that owners can do to keep the mower in good working condition. For any service or repair issues beyond these, it is recommended that the unit be inspected by an Authorized California Trimmer Dealer.

IMPORTANT: Avoid damage! Operating in extreme conditions may require more frequent service intervals. Engine components may become dirty or plugged when operating in extreme heat, dust or other severe conditions.

DAILY INSPECTION FOR COMMERCIAL USE EVERY 8 HOURS FOR NON-COMMERCIAL USE

- Check engine oil level and air cleaner per the engine manufacturer's instructions.
- Inspect the cutting blades for damage and movement – NOTE: the blades are reversible and use only genuine California Trimmer replacement parts.

⚠ WARNING

- Do not operate the unit without tri-blades or bar blades properly installed.
- Remove debris and grass from the engine mounting base area and the engine air intake – which is part of the recoil starter.
- Check the impeller and mower deck for cracks or damage.
- Check the tightness of the handle mounts.
- Clean excess grass buildup from the underside of the deck.
- Replacement parts are available from Authorized California Trimmer Dealers. The parts manual is available for download at: Caltrimmer.com



HOVER MOWER OPERATOR'S MANUAL

LIMITED WARRANTY STATEMENT

California Trimmer hereby warrants its products to be free from defects in material or workmanship for a period two years after purchase for non-commercial / non-rental consumer use. This warranty applies only to non-engine components and functions. The engine warranty coverage is provided by the respective manufacturer and is subject to their specific requirements and conditions. If the product is used in a commercial application, the warranty period shall be one year after purchase. Consumer use under the terms of warranty is defined as operation at a personal home or residence. Commercial application under the terms of warranty is defined as use in conjunction with an income producing business or commercial, institutional or municipality grounds maintenance.

This warranty is limited to repair or replacement by California Trimmer or at the premises of Authorized Service Dealers, of such parts as appear upon inspection, to be defective in material and/or workmanship. The above warranties are extended only to the first end user, and no warranty is made nor authorized to be made assignable on resale. California Trimmer makes no warranty with respect to replacement parts not manufactured or sold by it. Such parts are subject to the warranty policy of their respective manufacturers. For the name and address of your nearest Authorized Service Dealer, contact California Trimmer at: 1028 4th Street SW, Building A, Auburn WA 98001, (253) 333-3345 or online at <http://Caltrimmer.com>. To obtain performance of any obligation under this warranty for failure during the applicable warranty period, deliver the product, shipping prepaid, to California Trimmer, or to the nearest Authorized Service Dealer. Warranty coverage is conditioned upon the first end user furnishing California Trimmer or its Authorized Service Dealer with adequate written proof of the original purchase date. California Trimmer reserves the right to inspect the claimed defective part(s) to determine if the malfunction is the result of a defect covered by this warranty.

This warranty will cover only defects arising under normal usage, and shall not apply, nor will California Trimmer assume any responsibility, if the failure was caused by the following:

1. Operation of product without proper lubrication.
2. Misuse, abuse, or negligence.
3. Accident or physical damage.
4. Repairs made by unauthorized parties and/or with unauthorized parts.
5. Improper unit set up or altered components.
6. Improper adjustments i.e. blades, drive system, levers, cables, nozzles, pump motors, etc.
7. Operation of engine at speeds above the manufacturer's recommendations.
8. Failure to operate or maintain the unit in the manner specified by the owner's manual.

Inspection, service and adjustments to normal maintenance items such as grease fittings, blades, drive chains, engagement levers, etc. are not considered the responsibility of California Trimmer under this warranty.

THIS LIMITED WARRANTY IS IN LIEU OF ALL OTHER EXPRESS WARRANTIES, OBLIGATIONS, OR LIABILITIES. ANY IMPLIED WARRANTIES, OBLIGATIONS, OR LIABILITIES INCLUDING, BUT NOT LIMITED TO, ANY IMPLIED WARRANTY OF MERCHANTABILITY OR FITNESS FOR A PARTICULAR PURPOSE SHALL BE LIMITED IN DURATION TO THE APPLICABLE WARRANTY PERIOD FOR THE FIRST END USER (TWO YEARS FOR NON-COMMERCIAL USE; 1 YEAR FOR COMMERCIAL USE. ANY ACTION FOR BREACH OF ANY WARRANTY HEREUNDER INCLUDING, BUT NOT LIMITED TO, ANY IMPLIED WARRANTY OF MERCHANTABILITY OR FITNESS FOR A PARTICULAR PURPOSE MUST BE BROUGHT WITHIN A PERIOD OF SIX MONTHS FROM THE END OF THE APPLICABLE WARRANTY PERIOD.

Some states do not allow limitations on how long an implied warranty lasts, so the previously stated limitations may not apply to you. No agent, representative, dealer, or employee of California Trimmer has the authority to increase or alter the obligations of this warranty.

IF THE PRODUCT IS USED PRIMARILY IN A COMMERCIAL APPLICATION, CALIFORNIA TRIMMER WILL NOT BE LIABLE FOR GENERAL DAMAGES INCLUDING BODILY INJURIES, EXCEPT AS SET FORTH ABOVE, OR FOR INCIDENTAL OR CONSEQUENTIAL DAMAGES INCLUDING, BUT NOT LIMITED TO, LOSS OF USE, LOSS OF PROFITS, LOSS OF PRODUCTION, EXPENSE OF SUBSTITUTE EQUIPMENT OR OTHER COMMERCIAL LOSS OR DAMAGE. THE SAME LIMITATIONS SHALL APPLY TO A PRODUCT USED FOR CONSUMER PURPOSES WITH RESPECT TO ALL NON-PERSONAL INJURY, GENERAL INCIDENTAL AND CONSEQUENTIAL DAMAGES.

Some states do not allow the exclusion or limitation of incidental or consequential damages, so the above limitation or exclusion may not apply to you. This warranty gives you specific legal rights, and you may also have other rights which vary from state to state.

Free Manuals Download Website

<http://myh66.com>

<http://usermanuals.us>

<http://www.somanuals.com>

<http://www.4manuals.cc>

<http://www.manual-lib.com>

<http://www.404manual.com>

<http://www.luxmanual.com>

<http://aubethermostatmanual.com>

Golf course search by state

<http://golfingnear.com>

Email search by domain

<http://emailbydomain.com>

Auto manuals search

<http://auto.somanuals.com>

TV manuals search

<http://tv.somanuals.com>