

i9900

SERVICE MANUAL

Canon

Copyright 2004, Canon U.S.A. This technical publication is the proprietary and confidential information of Canon U.S.A. which shall be retained for reference purposes by Authorized Service Facilities of Canon U.S.A. Its unauthorized use is prohibited.

i9900/i9950

REFERENCE MANUAL

Revision 0

QY8-1397-000

Scope

This manual has been issued by Canon Inc., to provide the service technicians of this product with the information necessary for qualified persons to learn technical theory, installation, maintenance, and repair of products. The manual covers information applicable in all regions where the product is sold. For this reason, it may contain information that is not applicable to your region.

Revision

This manual could include technical inaccuracies or typographical errors due to improvements or changes made to the product. When changes are made to the contents of the manual, Canon will release technical information when necessary. When substantial changes are made to the contents of the manual, Canon will issue a revised edition.

The following do not apply if they do not conform to the laws and regulations of the region where the manual or product is used:

Trademarks

Product and brand names appearing in this manual are registered trademarks or trademarks of the respective holders.

Copyright

All rights reserved. No parts of this manual may be reproduced in any form or by any means or translated into another language without the written permission of Canon Inc., except in the case of internal business use.

Copyright 2004 by Canon Inc.

CANON INC.

Inkjet Products Quality Assurance Div.

16-1, Shimonoge 3-chome, Takatsu-ku, Kawasaki, Kanagawa 213-8512, Japan

I. MANUAL OUTLINE

This manual outlines the main service information for the i9900 / i9950 models.

Product names, availability of CD-R printing, and destination are as follows.

Product name	Availability of CD-R printing	Destination
i9950	Yes	EUR/ASA HVT/AU/GB/TW/HK/CN/EUM
i9900	No	US/CA/LAM LVT/LAM HVT/KR
PIXUS 9900i	Yes	JPN

II. TABLE OF CONTENTS

Part 1: MAINTENANCE

1-1	1. MAINTENANCE
1-1	1.1 Adjustment, Periodic Maintenance, Periodic Replacement Parts, and Replacement Consumables by Service Engineer
1-2	1.2 Customer Maintenance
1-3	1.3 Product Life
1-3	1.4 Special Tools
1-3	1.5 Serial Number Location
1-4	2. LIST OF ERROR DISPLAY / INDICATION
1-4	2.1 Operator Call Errors (LED Blinks in Orange)
1-6	2.2 Service Call Errors (LED Blinks in Orange and Green Alternately, or Lights in Orange)
1-6	2.3 Warnings
1-7	2.4 Troubleshooting by Symptom
1-9	3. REPAIR
1-9	3.1 Disassembling / Reassembling flow for main units
1-10	3.2 Notes on Service Part Replacement (and Disassembling / Reassembling)
1-11	3.3 Special Notes on Repair Servicing
	(1) Flexible cable and harness wiring, connection
	(2) Notes on after repair for trouble concerning printing or re-installation of the print head
1-12	3.4 (1) Paper feed motor adjustment
	(2) Gear phase adjustment
1-13	(3) Grease application
1-14	(4) Waste ink counter setting
1-15	(5) User mode
1-15	(6) Service mode
1-17	(7) Flash ROM upgrade
1-17	3.5 Verification Item
	(1) Service test print
1-20	(2) EEPROM information print
1-22	4. PRINTER TRANSPORTATION METHOD

Part 2: TECHNICAL REFERENCE

2-1	1. NEW TECHNOLOGIES
2-4	2. CLEANING MODE AND AMOUNT OF INK PURGED
2-5	3. PRINT MODE
	3.1 Resolution
	(1) Standard color printing
2-6	(2) Standard gray scale printing (Paper types different than those for color printing only are listed.)
2-7	(3) Borderless printing
	(4) Duplex printing
2-8	(5) Camera Direct Printing
2-9	4. FAQ (Specific Problems and Solutions)
2-10	5. SPECIFICATIONS
2-10	5.1 Printer Specifications
2-11	5.2 Printer Head Specifications
	5.3 Comparison with PIXUS 9100i / i9100

Part 3: APPENDIX

3-1	1. BLOCK DIAGRAM
3-2	2. CONNECTOR LOCATION AND PIN LAYOUT
3-2	2.1 Logic Board Ass'y
3-6	2.2 Carriage Board (print head connection terminals)

Part 1

MAINTENANCE

1. MAINTENANCE

1.1 Adjustment, Periodic Maintenance, Periodic Replacement Parts, and Replacement Consumables by Service Engineer

(1) Adjustment

Adjustment	Timing	Purpose	Tool	Approx. time
EEPROM initialization (EEPROM settings)	At logic board ass'y replacement	To initialize settings other than the following: - USB serial number - Destination setting - Waste ink counter - Media sensor correction value - CD-R correction value - Correction value for the CDR sensor and automatic print head alignment sensor	None.	1 min.
Destination settings (EEPROM settings)	At logic board ass'y replacement	To set the destination.	None.	1 min.
Waste ink counter resetting (EEPROM settings)	- At bottom case/output tray unit (bottom case unit) replacement - At ink absorber replacement	To reset the waste ink counter.	None.	1 min.
Media sensor correction ^{*1} (EEPROM settings)	- At logic board ass'y replacement - At sheet feeder unit replacement	To correct the media sensor.	Calibration media kit (QY9-0064) ^{*2}	2 min.
Correction for the CD-R sensor and automatic print head alignment sensor (EEPROM settings)	- At logic board ass'y replacement - At carriage unit replacement	To correct the CD-R sensor and automatic print head alignment sensor.	None. (Correction performed through service test print)	1 min.
Print head alignment	- At print head replacement - At logic board ass'y replacement	To ensure accurate dot placement.	Computer (settings via the printer driver)	3 min.
Paper feed motor position adjustment ^{*3}	At paper feed motor unit replacement	To adjust the belt tension. (Position the paper feed motor so that the belt is stretched tight.)	None.	2 min.
Grease/oil application ^{*4}	- At carriage shaft/grease pad replacement - At paper guide flapper ass'y/carriage slide sheet/shaft clip replacement - At lift base gear part replacement - At gear box replacement	- To maintain sliding properties of the carriage and paper guide flapper. - To protect the lift base gear. - To maintain sliding properties of the operation lever	- FLOIL KG-107A (QY9-0057) - MOLYKOTE PG641 (CK-0562) - EU-1 (QY9-0037)	2 min.

Cautions after print head installation* ⁵	- After repair for trouble concerning printing - After re-installation of the print head (Before returning to users)	- To prevent non-ejection of ink at initial printing (Empty ink from print head once.)	None.	6 min.
--	---	--	-------	--------

Note: DO NOT loosen the red screws on both sides of the main chassis securing the carriage shaft position.

*1: Media sensor correction

This operation adjusts the correction value of the media sensor, installed in the sheet feeder unit, to the EEPROM of the logic board ass'y. The adjustment is required when the sheet feeder unit or the logic board ass'y is replaced, and values are automatically determined via use of calibration media kit (QY9-0064).

*2: Calibration media kit

The service tool for media sensor correction, consisting of 10 sheets of the reference plain paper, and 1 sheet of the reference white PET paper.

*3: Red screws of paper feed motor

The red screws securing the paper feed motor may be loosened only at replacement of the paper feed motor unit.

*4: For details, see [Section 3.4 Adjustment / Settings](#).

*5: Cautions after repair for trouble concerning printing or the print head re-installation

After repair for trouble concerning printing or the print head re-installation, after emptying the ink in the print head, (if users sent the printer with ink tanks, re-set it with ink tanks) and return the printer to users. (See [Section 3.3 Special Notes on Repair Servicing \(2\) Notes on after repair for trouble concerning printing or re-installation of the print head.](#))

(2) Periodic maintenance

No periodic maintenance is necessary.

(3) Periodic replacement parts

There are no parts in this printer that require periodic replacement by a service engineer.

(4) Replacement consumables

There are no consumables that require replacement by a service engineer.

1.2 Customer Maintenance

Adjustment	Timing	Purpose	Tool	Approx. time
Print head alignment	At print head replacement.	To ensure accurate dot placement.	Computer (Automatic settings via the printer driver)	5 min.
Print head cleaning	When print quality is not satisfying.	To improve nozzle conditions.	- Printer buttons - Computer (settings via the printer driver)	30 sec. to 1 min.
Print head deep cleaning	When print quality is not satisfying, and not improved by print head cleaning.	To improve nozzle conditions.	Computer (settings via the printer driver)	1 to 1.5 min.
Ink tank replacement	When an ink tank becomes empty. (No ink error)	-----	-----	2 min.
Paper feed roller cleaning	When paper does not feed properly	To clean the paper feed rollers.	Printer buttons	2 min.
CD-R print position alignment	When printing to CD-R	To ensure accurate CD-R print position	Computer (Settings via the application)	5 min.
Cleaning inside the printer	When the backside of paper is dirty.	To remove ink mist adhered to the platen rib, using a cloth.	-----	1 min

1.3 Product Life

(1) Printer

The value from (i) to (iii), whichever comes first.

- (i) 10,000 pages of color printing
 - Color: 7.5% duty per color pattern printing, A4
- (ii) 1,200 discs of CD-R/DVD-R printing
 - On a basis of monthly print volume of approx. 20 discs
- (iii) 5 years of use

(2) Print head

- 10,000 pages of color printing
 - Color: 7.5% duty per color pattern printing, A4

(3) Ink tank

- BCI-6BK: 740 pages (1,500 character pattern in black printing, plain paper, standard mode)
1,100 pages (ISO JIS-SCID No. 5 pattern, plain paper, standard mode)
- BCI-6C: 1,100 pages (ISO JIS-SCID No. 5 pattern, plain paper, standard mode)
- BCI-6M: 790 pages (ISO JIS-SCID No. 5 pattern, plain paper, standard mode)
- BCI-6Y: 540 pages (ISO JIS-SCID No. 5 pattern, plain paper, standard mode)
- BCI-6PC: 380 pages (ISO JIS-SCID No. 5 pattern, plain paper, standard mode)
- BCI-6PM: 280 pages (ISO JIS-SCID No. 5 pattern, plain paper, standard mode)
- BCI-6R: 2,300 pages (ISO JIS-SCID No. 5 pattern, plain paper, standard mode)
- BCI-6G: 2,300 pages (ISO JIS-SCID No. 5 pattern, plain paper, standard mode)

1.4 Special Tools

Name	Tool No.	Purpose	Remarks
MOLYKOTE PG641	CK-0562-000	To be applied to the lift base bushing, the lift gear, the gear box, and the CD-R tray lever	In common with conventional models
FLOIL KG-107A	QY9-0057-000	To be applied to the sliding portions of the carriage slider sheet, carriage shaft clip, the paper guide flapper, and the idle pulley	In common with conventional models
EU-1	QY9-0037-000	To be applied to the sliding portion of the carriage, and the oil pad on the carriage	In common with conventional models
Calibration media kit	QY9-0064-000	To correct the media sensor	In common with conventional models

1.5 Serial Number Location

On the label on the chassis (visible to the right of the flexible cable when the access cover is open).

The image to the right is an example for the PIXUS 9900i model: FBYX10885



2. LIST OF ERROR DISPLAY / INDICATION

Errors are indicated by the LED, and warnings are displayed on the monitor of the computer connected to the printer.

2.1 Operator Call Errors (LED Blinks in Orange)

LED Blinks in orange	Error	Solution	Remarks
2 times	No paper. / Pick up failure. (Sheet feeder unit) [1000]	Set paper (set properly again.) in the Sheet feeder unit, and press the Resume/Cancel button.	
	No CD-R tray [1001]* ¹	Set the CD-R tray* ² , and press the Resume/Cancel button.	Adjust the mark on the CD-R tray to the mark on the paper output tray. * ³
3 times	Paper jam. [1300]	Remove the jammed paper, and press the Resume/Cancel button.	
4 times	No ink. [1601/1611/1612/1613/1614/1634/1635]	Replace the empty ink tank(s), or press the Resume/Cancel button.	Pressing the Resume/Cancel button will exit the error without ink tank replacement, however, ink may run out during printing.
5 times	The print head is not installed [1401], or it is not properly installed (EEPROM data of the print head is faulty) [1403/1405].	Install the print head properly, and close the access cover. Or, with the print head installed, turn the printer off and on.	
6 times * ¹	The paper output tray is in the CD-R printing position. (On paper printing) [1850/1855]	Remove the CD-R tray* ² , set the paper output tray in the paper printing position, and press the Resume/Cancel button.	
	The paper output tray is in the paper printing position. (On CD-R printing) [1851/1856]	Set the paper output tray in the CD-R printing position, set the CD-R tray* ² , and press the Resume/Cancel button.	
7 times * ¹	NO CD-R/DVD-R [1002] * ¹	Set the CD-R/DVD-R on the CD-R tray* ² , set the CD-R tray* ² , and press the Resume/Cancel button.	
8 times	Warning: The waste ink absorber is almost full (approx. 95% of the maximum capacity). [1700]	Pressing the Resume/Cancel button will exit the error, and enable printing. In repair servicing, replace the bottom case/output tray unit (bottom case unit), or the ink absorbers.	The waste ink full error (service call error) may occur.
9 times	The connected digital camera or digital video camera does not support Camera Direct Printing. [2001]	After removing the cable connecting the camera and the printer, press the Resume/Cancel button, and re-connect the cable.	When a camera supporting direct printing is connected, the LED blinks in green two times.

(Operator Call Errors - cont'd -)

LED blinking in orange	Error	Solution	Remarks
11 times	Automatic print head alignment failure [2500]	Press the Resume/Cancel button, and after confirming the following, perform print head alignment again: <ul style="list-style-type: none">- Set an appropriate type and size of paper (plain paper, A4 or letter).- Check that the print head alignment pattern is properly printed (all ink ejected, no faint printing).- Check that the paper ejection slot is not exposed to light.- When there are no problems in the three items above, perform manual print head alignment.	

*1: Only the i9950 model supports CD-R printing.

*2: Use the CD-R tray with a "A" mark in the lower left. (Using a CD-R tray with no mark is not possible.)



Use the CD-R tray with an "A" mark.

When not performing CD-R printing, store the CD-R tray by hanging it on the projections on the back side of the printer.

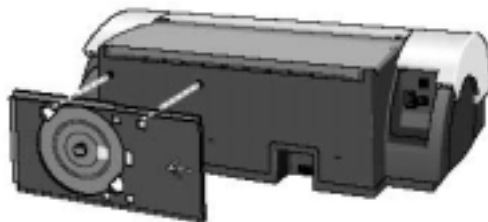

*3: When setting the CD-R, align the marks on the CD-R tray to the marks on the paper output tray.



2.2 Service Call Errors (LED Blinks in Orange and Green Alternately, or Lights in Orange)

LED blinks alternately in orange and green	Error	Solution (Replacement of listed parts, which are likely to be faulty)
2 times	Carriage error [5100]	- Carriage unit (QM2-1306) - Timing slit strip film (QC1-4520) - Logic board ass'y (QM2-1272/QM2-1273) ^{*1} - Carriage motor (QK1-0175)
3 times	Paper feed error [6000]	- Timing sensor unit (QM2-1322) - Timing slit disk film (QC1-2484) - Feed roller ass'y (QL2-0626) - Platen unit (QM2-1304/1327) - Logic board ass'y (QM2-1272/QM2-1273) ^{*1} - Paper feed motor unit (QK1-0637)
4 times	Purge unit error [5C00]	- Purge unit (QM2-1307) - Logic board ass'y (QM2-1272/QM2-1273) ^{*1}
6 times	Internal temperature error [5400]	- Logic board ass'y (QM2-1272/QM2-1273) ^{*1}
7 times	Waste ink absorber full [5B00]	- Ink absorber (QC1-4613/4614/4615/4641) - Bottom case unit (QM2-1325) ^{*3} - Bottom case/Output tray unit (QM2-1328) ^{*3}
8 times	Print head temperature rise error [5200]	- Print head (QY6-0055) - Logic board ass'y (QM2-1272/QM2-1273) ^{*1}
9 times	EEPROM error [6800]	- Logic board ass'y (QM2-1272/QM2-1273) ^{*1}
10 times ^{*2}	Carriage lift mechanism error [5110]	- Lift input gear shaft (QC1-2657) - Photo interrupter (WG8-5571) - Lift cam harness ass'y (QM2-1281) - Sheet feeder unit (QM2-1329) - Logic board ass'y (QM2-1272/QM2-1273) ^{*1}
12 times	Media sensor error [8000]	- Sheet feeder unit (QM2-1329)
13 times	USB Host VBUS overcurrent [9000]	- Logic board ass'y (QM2-1272/QM2-1273) ^{*1}
15 times	Other hardware error [6500]	- Logic board ass'y (QM2-1272/QM2-1273) ^{*1}
Continuous alternate blinking	Flash ROM error	- Logic board ass'y (QM2-1272/QM2-1273) ^{*1}
Lights in orange	RAM error	- Logic board ass'y (QM2-1272/QM2-1273) ^{*1}

*1: Before replacement of the logic board ass'y, check the waste ink amount (by service test print or EEPROM information print). If the waste ink amount is 7% or more, also replace the bottom case/output tray unit (bottom case unit) or the complete set of the ink absorbers when replacing the logic board ass'y. [See Section 3.4. Adjustment / Settings, \(6\) Service mode, for details.](#)

*2: Only for the 9950i model supporting CD-R printing.

*3: Reset the waste ink counter when replacing the bottom case/output tray unit (bottom case unit). [See Section 3.4. Adjustment / Settings, \(6\) Service mode, for details.](#)

2.3 Warnings

(1) Printer (no LED indications)

Displayed warning	Remarks
Low ink of 6BK, 6C, 6M, 6Y, 6PC, 6PM, 6R, and 6G (at detection of no remaining raw ink)	The status is displayed on the monitor of the computer connected to the printer.
Print head temperature rise warning	If the print head temperature is high when the access cover is opened, the warning is displayed ^{*1} . When the print head temperature falls, the warning is released.
Print head temperature excess rise protection	If the print head temperature exceeds the specified limit, a Wait is inserted during

	printing.
The paper output tray is in the CD-R printing position. (When printing on paper) * ²	The paper output tray is in the CD-R printing position when the access cover is opened. When the paper output tray is set in the paper printing position and the access cover is closed, the warning is released.
The paper output tray is in the paper printing position. (When printing on CD-R) * ²	The paper output tray is in the paper printing position when the access cover is opened. When the paper output tray is set in the CD-R printing position and access cover is closed, the warning is released.

*1: If the warning is displayed, the carriage does not move to the ink tank replacement position when the access cover is opened.

*2: Only for the i9950 model supporting CD-R printing.

2.4 Troubleshooting by Symptom

	Symptom	Solution	Remarks
Faulty operation	The power does not turn on. The power turns off immediately after power-on.	Replace the - AC adapter, or - logic board ass'y * ¹ .	
	The print head is not recognized. The print head does not move to the home position.	Remove and re-install the print head, or replace the - print head, or - logic board ass'y * ¹ , or - carriage unit.	
	A strange noise occurs.	Remove foreign material, or attach a removed part if any.	
	Printing stops mid-way.	Replace the logic board ass'y * ¹ , or the - print head.	
Paper feed problems	Multiple sheets feed.	Replace the - sheet feeder unit.	
	Paper does not feed.	Remove foreign material, or replace the - sheet feeder unit.	
	Paper feeds at an angle.	Remove foreign material, adjust paper and the paper guide, or replace the - sheet feeder unit.	

(Troubleshooting by Symptom - cont'd -)

	Symptom	Solution	Remarks
Unsatisfactory print quality	No printing, or no ink ejected. ^{*3}	Replace the - ink tank, - print head ^{*2} , - logic board ass'y ^{*1} , or - purge unit.	Perform the cleaning operation (for all colors)
	Printing is faint, or white lines appear on printouts even after print head cleaning. ^{*3} Line(s) not included in the print data appears on printouts.	Remove and re-install the print head, or replace the - ink tank, - print head ^{*2} , - purge unit, or - logic board ass'y ^{*1} .	
	Paper gets smeared.	Feed several sheets of paper, or clean the paper path and ribs on the platen with cotton swab or cloth.	
	A part of a line is missing on printouts. ^{*3}	Replace the - ink tank, or - print head ^{*2} .	
	Color hues are incorrect.	Replace the - ink tank, or - print head ^{*2} , or correct the media sensor, or check the ink tank setting position.	Perform the cleaning operation (for all colors)
	Printing is incorrect.	Replace the logic board ass'y ^{*1} .	
	No ejection of ink. ^{*3}	Replace the - ink tank, or - print head ^{*2} .	Perform the cleaning operation (for all colors)
Graphic or text is enlarged on printouts.	When enlarged in the carriage movement direction, clean grease or oil off the timing slit strip film, or replace the - timing slit strip film, - carriage unit, or - logic board ass'y ^{*1} . When enlarged in the paper feed direction, clean grease or oil off the timing slit strip film, or replace the - timing slit disk film, - timing sensor unit, or - logic board ass'y ^{*1} .		

*1: Before replacement of the logic board ass'y, check the waste ink amount (by service test print or EEPROM information print). If the waste ink amount is 7% or more, also replace the bottom case/out put tray unit (bottom case unit) or the complete set of ink absorber when replacing the logic board ass'y. [See Section 3.4 Adjustment / Settings, \(6\) Service mode, for details.](#)

*2: Replace the print head only after the print head deep cleaning is performed 2 times, and when the problem persists.

*3: Before returning the printer to users, empty ink in the print head once.
([See Section 3.3 Special Notes on Repair Servicing \(2\) Notes on after repair for trouble concerning printing or re-installation of the print head.](#))

3. REPAIR

3.1 Disassembling/Reassembling flow for main units

The flow chart below shows decomposition in descending order, and assemble in ascending order. (Refer to the PIXUS 9900i/i9900/i9950 Parts Catalogue for details.)

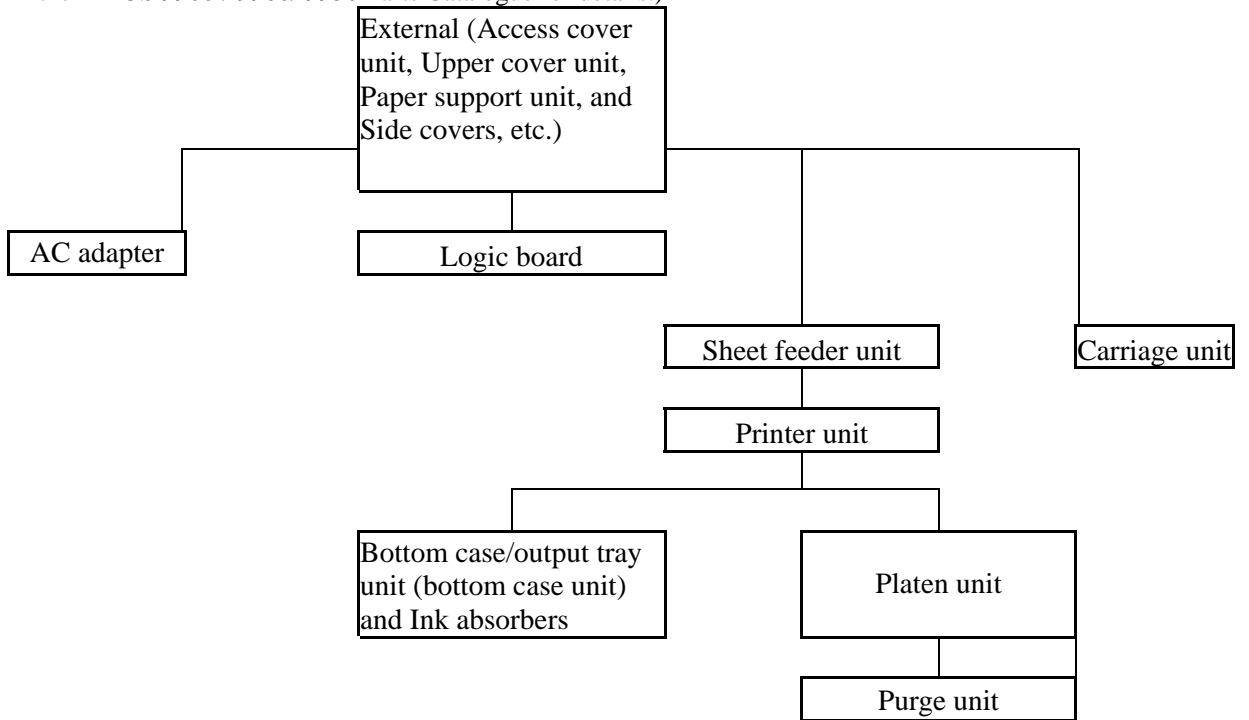

Reference: Example for the i9100 model (Refer to the PIXUS 9100/i9100 Parts Catalogue for details)

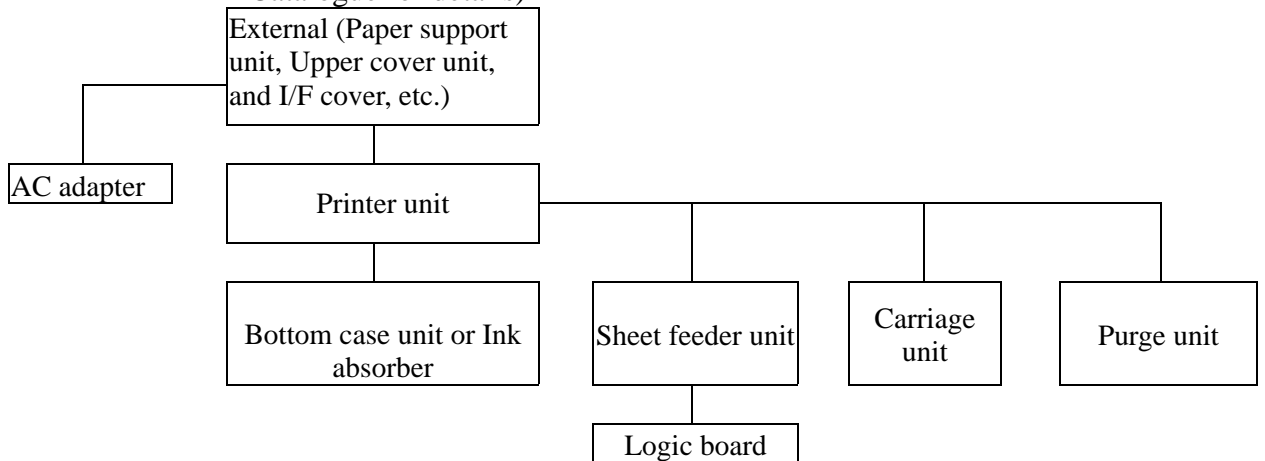

3.2 Notes on Service Part Replacement (and Disassembling / Reassembling)

Service part	Notes on replacement*1	Adjustment / settings	Operation check
Logic board ass'y (QM2-1272/ QM2-1273)	<ul style="list-style-type: none"> - Before removal of the logic board ass'y, remove the power cord, and allow for approx. 1 minute (for discharge of capacitor's accumulated charge), to prevent damage to the logic board ass'y. - Before replacement, check the waste ink amount (by service test print or EEPROM information print). If the waste ink amount is 7% or more, also replace the bottom case/output tray unit (bottom case unit) or the ink absorber when replacing the logic board ass'y. See Section 3.4. Adjustment / Settings, (6) Service mode, for details. 	<p>After replacement:</p> <ol style="list-style-type: none"> 1. Initialize the EEPROM. 2. Reset the waste ink counter (If the waste ink amount is 7% or more.) 3. Set the destination in the EEPROM. 4. Correct the media sensor. 5. Correct the CD-R and automatic print head alignment sensor. <p>For details of 1 to 5, see Section 3.4. Adjustment / Settings, (6) Service mode.</p> <ol style="list-style-type: none"> 6. Perform the print head alignment in the user mode. 	<ul style="list-style-type: none"> - EEPROM information print - Service test print - Printing via USB connection - Direct printing from a digital camera
Bottom case/Output tray unit (QM2-1328) Bottom case unit (QM2-1325) Ink absorber (QC1-4513/4514/4515/4641)		<p>After replacement:</p> <ol style="list-style-type: none"> 1. Reset the waste ink counter. See Section 3.4. Adjustment / Settings, (6) Service mode. 	<ul style="list-style-type: none"> - Service test print
Sheet feeder unit (QM2-1329)		<p>After replacement:</p> <ol style="list-style-type: none"> 1. Correct the media sensor. See Section 3.4. Adjustment / Settings, (6) Service mode. 	<ul style="list-style-type: none"> - Service test print (Confirm media sensor correction.)
Carriage unit (QM2-1306)		<p>At replacement:</p> <ol style="list-style-type: none"> 1. Apply grease to the sliding portions. See Section 3.4. Adjustment / Settings, (3) Grease application. <p>After replacement:</p> <ol style="list-style-type: none"> 1. Correct the CD-R and automatic print head alignment sensor. See Section 3.4. Adjustment / Settings, (6) Service mode. 2. Perform the print head alignment in the user mode. 	<ul style="list-style-type: none"> - Service test print (Confirm CD-R and automatic print head alignment sensor correction.)
Paper feed motor unit (QK1-0637)	<ul style="list-style-type: none"> - Only the red screws securing the paper feed motor can be loosened. (DO NOT loosen any other red screws.) 	<p>At replacement:</p> <ol style="list-style-type: none"> 1. Adjust the paper feed motor. See Section 3.4. Adjustment / Settings, (1) Paper feed motor adjustment. 	<ul style="list-style-type: none"> - Check that paper is fed through.

(Notes on Service Part Replacement and Disassembling / Reassembling - cont'd-)

Service part	Notes on replacement* ¹	Adjustment / settings* ²	Operation check
Carriage Lift Part (QC1-2298, 2301, 2657, 4361, 4527, 4621, and 4632)		At replacement: 1. Apply grease to QC1-4527 (lift input, gear)/2301 (bushing) See Section 3.4. Adjustment / Settings, (3) Grease application.	- Service test print - (CD-R test print)
Timing slit strip film (QC1-4520)	- Upon contact with the film, wipe the film with ethanol. - Confirm no grease is on the film. (Wipe off any grease thoroughly with ethanol.) - Do not bend the film.	After replacement: 1. Perform the print head alignment in the user mode.	- Service test print
Timing slit disk film (QC1-2484)			
Print head (QY6-0055)		After replacement: 1. Perform the print head alignment in the user mode.	- Service test print

*1: General notes:

- After repair for trouble concerning printing or the print head re-installation, empty ink in the print head once, and return the printer to users.
[\(See Section 3.3. Special Notes on Repair Servicing \(2\) Notes on after repair for trouble concerning printing or re-installation of the print head.\)](#)
- Make sure that the flexible cables and wires in the harness are in the proper position and connected correctly. [See Section 3.3. Special Notes on Repair Servicing, \(1\) Flexible cable and harness wiring, connection, for details.](#)
- Do not drop the ferrite core, which may damage it.
- Protect electrical parts from damage due to static electricity.
- Before removing a unit, after removing the power cord, allow the printer to sit for approx. 1 minute (for capacitor discharge to protect the logic board ass'y from damage).
- Do not touch the timing slit strip film and timing slit disk film. No grease or abrasion is allowed.
- Avoid soiling the unit with ink.
- Protect the housing from scratches.
- Exercise caution with the red screws, as follows:
 - i. The red screws of paper feed motor may be loosened only at replacement of the paper feed motor unit (DO NOT loosen them in other cases).
 - ii. DO NOT loosen the red screws on both sides of the main chassis, securing the carriage shaft positioning (they are not adjustable in servicing).
- Exercise caution with replacement of the bottom case/output tray unit (only for the i9950 model)
When replacing QM2-1328 (the bottom case/output tray unit), replace QC1-4558, 4559, 4560, XD2-1100-322, and 2300-602.
(Once the E-ring is removed, it is not possible to use it again.)

3.3 Special Notes on Repair Servicing

(1) Flexible cable and harness wiring, connection

Exercise care when handling the flexible cable and harness wiring. Incorrect wiring may cause ignition or emission of smoke. [Refer to the PIXUS9900i/i9900/i9950 Parts Catalog.](#)

(2) Notes on after repair for trouble concerning printing or re-installation of the print head

After repair for trouble concerning printing or the print head re-installation, empty ink in the print head once, and return the printer to users. This is aimed at preventing non-ejection of ink at initial printing. Operational procedures are as follows.

1. When ink tanks were installed upon receipt of the printer from users.
 - 1) Remove the ink tanks.
 - 2) Perform print head deep cleaning (for all colors) three times.
 - * Through this step, ink in the print head is emptied.
 - 3) Remove the print head.
 - 4) Re-install the print head.
 - 5) Re-install the ink tanks.
 - 6) Perform service test printing, and check the print result.
 - [See Section 3.5. Verification Items \(1\) Service test print.](#)
2. When ink tanks were not installed upon receipt of the printer from users.
 - 1) Perform print head deep cleaning (for all colors) three times.
 - * Through this step, ink in the print head is emptied.
 - 2) Remove the print head.
 - 3) Re-install the print head.

3.4 Adjustment / Settings

(1) Paper feed motor adjustment

When installing the paper feed motor, the following procedures are required.

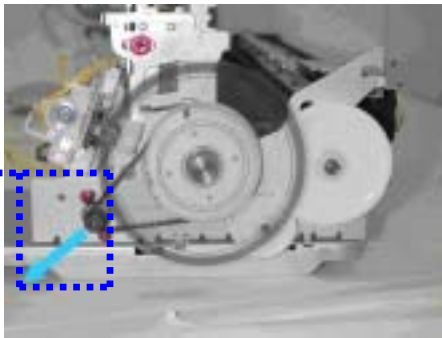

The red screws securing the paper feed motor

1) When installing the paper feed motor, fasten the screw while pulling in the direction of the arrow in the picture to set the belt is under tension.

2) After replacement of the paper feed motor, perform a service test print, and confirm that there are no abnormal sounds, or print results caused by an unseated belt, the motor being out of phase, or gear teeth problems.

Note: The red screws (displayed within the blue dotted lines in the image above) of the paper feed motor may be loosened only at replacement of the paper feed motor unit (DO NOT loosen them in other cases).

(2) Gear phase adjustment

For the i9900/i9950 model, **gear phase adjustment of the lift shaft gear is not necessary.**

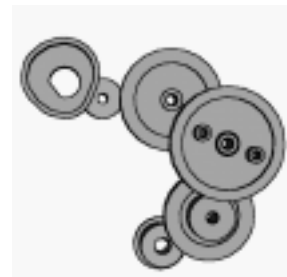

Grease application

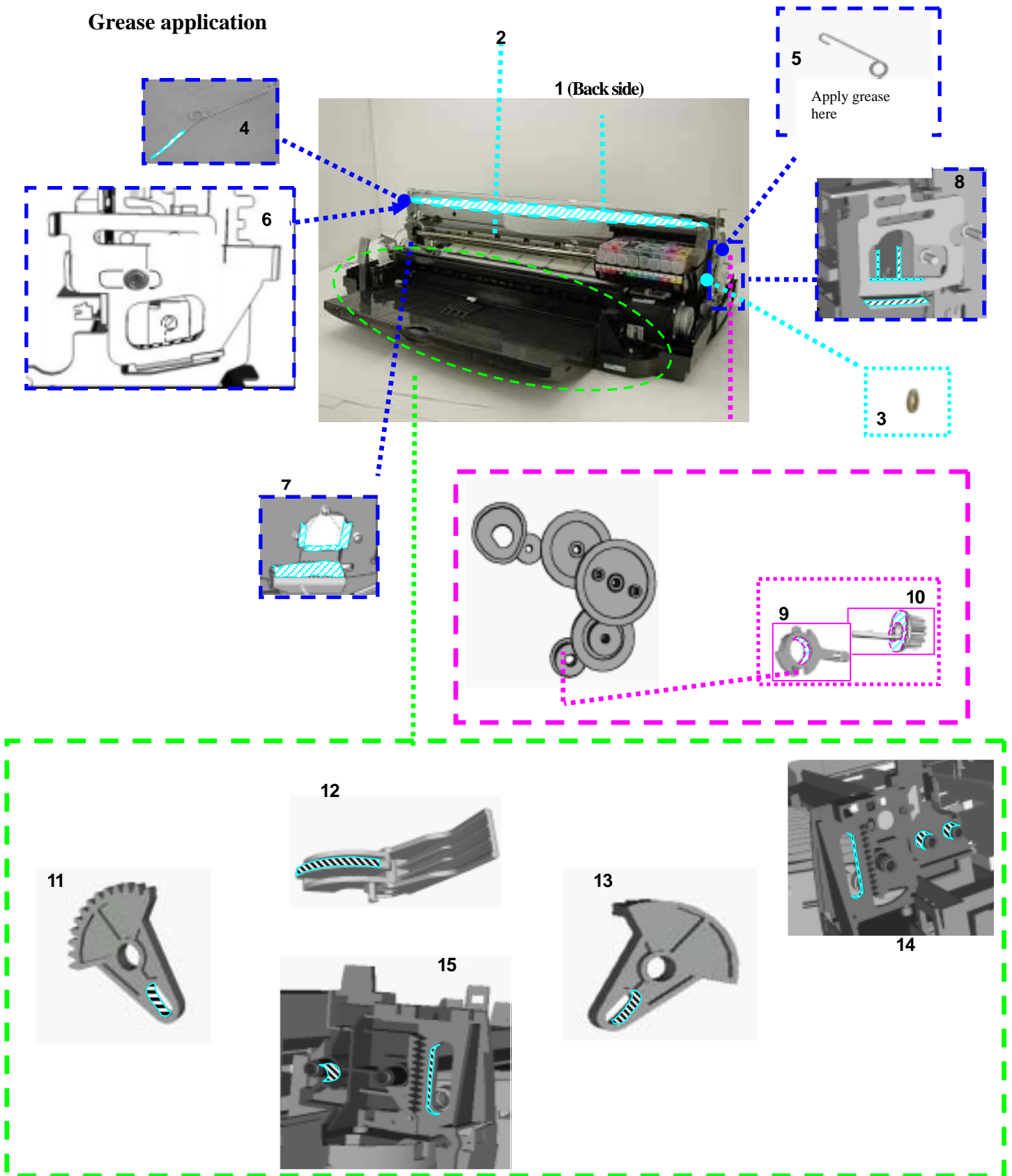

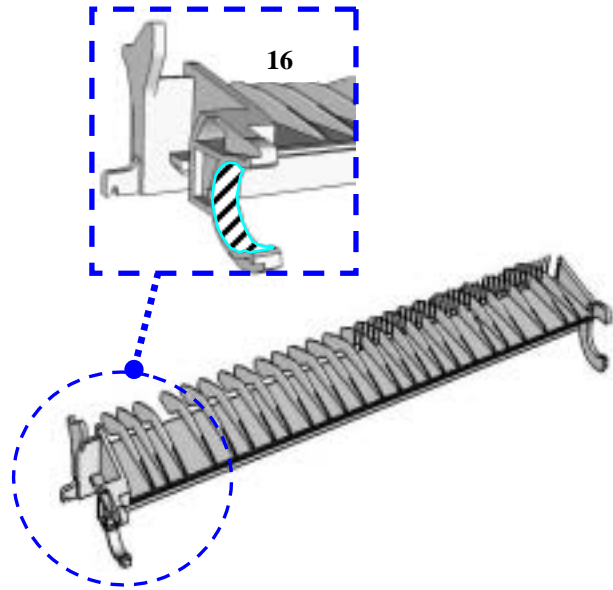

Part name		Where to apply grease / oil	Grease / oil name	Grease / oil amount
Carriage slide plate (QC1-4517)	1	Carriage unit sliding portion	FLOIL KG107A	26 to 40 mg
Carriage shaft (QC1 -4516)	2	Carriage unit sliding portion	EU1	70 to 160mg
Grease pad (QA4-0721) x 2	3	Carriage unit sliding portion	EU1	90 to 110mg
Shaft clip L (QC1-4654)	4	Carriage shaft sliding portion	FLOIL KG107A	Half drop each
Shaft clip R (QC1-4633)	5			
Adjust plate L	6	Carriage shaft sliding portion	MOLYKOTE PG641	1 drop
Adjust plate L, Chassis	7	Carriage shaft sliding portion Carriage shaft cam sliding portion	MOLYKOTE PG641	1 drop
Adjust plate R, Chassis	8	Carriage shaft sliding portion Carriage shaft cam sliding portion	MOLYKOTE PG641	1 drop
Lift base bushing (QC1-2301)	9	Lift base bushing inner surface	MOLYKOTE PG641	1 drop
Lift input gear (QC1-4527)	10	Lift base bushing sliding portion	MOLYKOTE PG641	1 drop
Lift gear L (QC1-4560)	11	Eject tray shaft sliding portion	MOLYKOTE PG641	1 drop
Operation lever	12	Eject tray shaft sliding portion	MOLYKOTE PG641	1 drop
Lift gear R (QC1-4559)	13	Eject tray shaft sliding portion	MOLYKOTE PG641	1 drop
Gear box R	14	Lift idler bushing, Eject tray shaft sliding portion	MOLYKOTE PG641	1 drop x 3 locations
Gear box L	15	Lift idler bushing, Eject tray shaft sliding portion	MOLYKOTE PG641	1 drop
Paper guide flapper ass'y	16	Siding portion between Carriage slider	FLOIL KG107A	2 drops

Note: 1 drop = 9 to 18 mg

(4) Waste ink counter setting

Waste ink amount ^{*1}	Replacement of Bottom case/Output tray unit (Bottom case unit) or Ink absorber
Less than 7 %	Not necessary
More than 7 %	Necessary

*1: For waste ink amount, refer to the service test print or EEPROM information print.

[See Section 3.4. Adjustment / Settings, \(6\) Service Mode](#)

(5) User mode

Function	Procedures	Remarks
----------	------------	---------

Print head manual cleaning	See “Standalone printer operation” below.	Also available from the printer driver’s Maintenance tab.
Print head deep cleaning	Perform from the printer driver utility.	
Pick up roller cleaning	See “Standalone printer operation” below.	
Nozzle check pattern printing	See “Standalone printer operation” below.	Also available from the printer driver’s Maintenance tab.
Print head alignment	Perform from the printer driver utility.	In Custom Settings of the printer driver’s Maintenance tab, manual print head alignment (by selecting the optimum values) as with the conventional models can be performed.
Print head replacement	The print head is replaceable at the same position as for ink tank replacement. (Open the access cover. When the carriage stops at the center, the print head can be replaced.)	

<Standalone printer operation>

- 1) Power on the printer.
- 2) Press and hold the Resume/Cancel button until the green LED blinks the specified number of times listed in the table below, and release it. The operation starts.

LED blinking	Operation	Remarks
1 time	Print head manual cleaning	
2 times	Nozzle check pattern printing	Set a sheet of plain paper (A4 or letter) in the ASF.
3 times	Pick up roller cleaning	
4 times	Automatic print head alignment (only for Bk and Cyan inks)	Set a sheet of plain paper (A4 or letter) in the ASF.
5 times or more	Unspecified	

(6) Service mode

Function	Procedures	Remarks
Service test print - Destination - ROM version - Waste ink amount - Number of pages printed - CD-R / automatic print head alignment sensor correction	See “Service mode operation procedures” below.	Set a sheet of A4/letter sized paper. (Set unused paper vertically.) For print sample, see Section 3.5. Verification Items, (1) Service test print, <Service test print sample>.
EEPROM initialization	See “Service mode operation procedures” below.	The following items are NOT initialized: - USB serial number - Destination settings - Waste ink counter - Media sensor correction value - CD-R correction value
Waste ink counter reset	See “Service mode operation procedures” below.	If the waste ink amount is 7% or more, replace the bottom case/out put tray unit (bottom case unit) or the ink absorber.
Destination settings	See “Service mode operation procedures” below.	Japan: PIXUS 9900i Overseas: - CD-R printing not supported (A4): i9900 - CD-R printing not supported (LTR): i9900 (LTR) - CD-R printing supported (A4): i9950 - CD-R printing supported (LTR): i9950 (LTR)

Note: At the end of the service mode, press the Power button. To protect the media sensor from being

dislocated during transportation, the paper lifting plate of the sheet feeder unit will be raised.

<Service mode operation procedures>

- 1) With the printer power turned off, while pressing the Resume/Cancel button, press and hold the Power button. (Do not release the buttons. The LED lights in green to indicate that a function is selectable.)
- 2) While holding the Power button, release the Resume/Cancel button. (Do not release the Power button.)
- 3) While holding the Power button, press the Resume/Cancel button 2 times, and then release the Power and Resume/Cancel buttons. (Each time the Resume/Cancel button is pressed, the LED lights alternately in orange and green, starting with orange.)
- 4) When the LED lights in green, press the Resume/Cancel button the specified number of time(s) according to the function listed in the table below. (Each time the Resume/Cancel button is pressed, the LED lights alternately in either orange or green, starting with orange.)
- 5) After the function (menu) is selected, press the Power button. The LED lights in green, and the selected function is performed. (When the operation completes, the printer returns to the menu selection mode automatically.)

Time(s)	LED	Function	Remarks
0 times	Green	Power off	When the print head is not installed, the carriage returns and locks in the home position.
1 time	Orange	Service test print	See Section 3.5 Verification Items, (1) Service test print.
2 times	Green	EEPROM information print	See Section 3.5 Verification Items, (2) EEPROM information print.
3 times	Orange	EEPROM initialization	
4 times	Green	Waste ink counter resetting	
5 times	Orange	Destination settings	After performing step 5), and follow the Destination settings procedures.
6 times	Green	Print head deep cleaning	
7 times	Orange	Media sensor correction	After performing step 5), and follow the Media sensor correction procedures.
8 times	Green	CD-R test print	Not used in servicing
9 times	Orange	CD-R print position correction (horizontal)	Not used in servicing
10 times	Green	CD-R print position correction (vertical)	Not used in servicing
11 times or more		Return to the menu selection	

<Destination settings procedures>

In the destination settings mode, press the Resume/Cancel button the specified number of time(s) according to the destination listed in the table below, and press the Power button.

Time(s)	LED	Destination
1 time	Orange	Japan: PIXUS 9900i
2 times	Green	Overseas, non-support of CD-R printing (A4): i9900
3 times	Orange	Overseas, non-support of CD-R printing (LTR): i9900 (LTR)
4 times	Green	Overseas, support of CD-R printing (A4): i9950
5 times	Orange	Overseas, support of CD-R printing (LTR): i9950 (LTR)
6 times or more		Return to the menu selection

Note: After setting the destination, confirm the model name in the service test print or EEPROM information print. ([See Section 3.5 Verification Items, \(1\) Service test print, or \(2\) EEPROM information print.](#))

<Media sensor correction procedures>

In the media sensor correction mode, using the reference white PET paper and reference plain paper of the calibration media kit (QY9-0064), press the Resume/Cancel button the specified number of times in the table below, and press the Power button. The media sensor correction operation must be performed once each with the reference white PET paper and the reference plain paper.

Time(s) of Resume/Cancel button	LED	Operation
1 time	Orange	Not used in servicing (In this mode, the set reference paper will be fed, and may be damaged. Please be careful not to select this mode.)
2 times	Green	Reference white PET paper correction value operation ^{*1}
3 times	Orange	Reference plain paper correction value operation ^{*2}
4 times or more		Return to the menu selection

Note:

- After each correction value operation, the mode returns to the service mode menu selection. After finishing either of the correction value operations, re-select the media sensor correction mode to perform the other correction value operation.
- After performing the media sensor correction, confirm the values of the media sensor in service test print or EEPROM information print. (See Section 3.5 Verification Items, (1) Service test print, or (2) EEPROM information print.)

*1: Reference white PET paper correction value operation

Set the A5-sized reference white PET paper (packed in the calibration media kit) in the sheet feeder in the landscape orientation. Then, press the Resume/Cancel button 2 times, and the Power button.

Note: There is no printing on the reference white PET paper. It can be placed with either side facing up, and with either edge at the top.

*2: Reference plain paper correction value operation

After setting a sheet of the A5-sized reference plain paper (packaged in the calibration media kit) in the sheet feeder, press the Resume/Cancel button 3 times, and the Power button.

The reference plain paper should be placed in the sheet feeder with the print side facing up, with the + marks printed area at top, so that it will feed in the direction indicated by the blue arrow in the figure.



(7) Flash ROM upgrade

Refer to the applicable Service Information (SI) bulletin announcing the upgrade.

3.5 Verification Items

(1) Service test print

<EEPROM information contents>

On the service test print (sample on the following page), confirm the EEPROM information as shown below. (The information is given in the upper portion of the printout.)

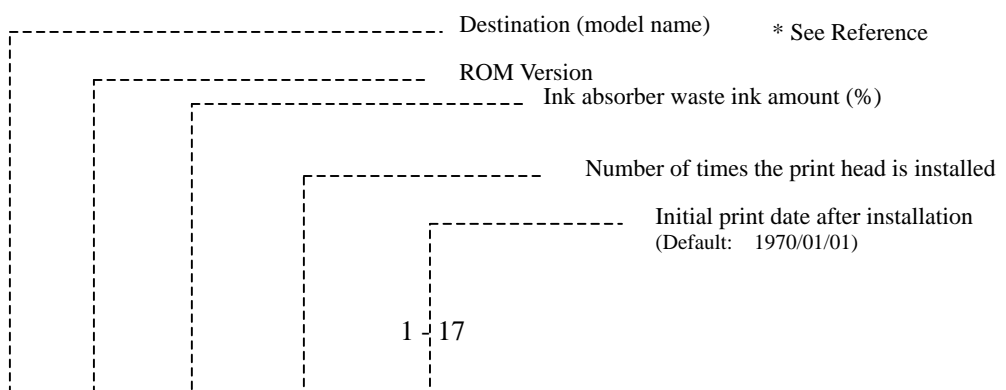

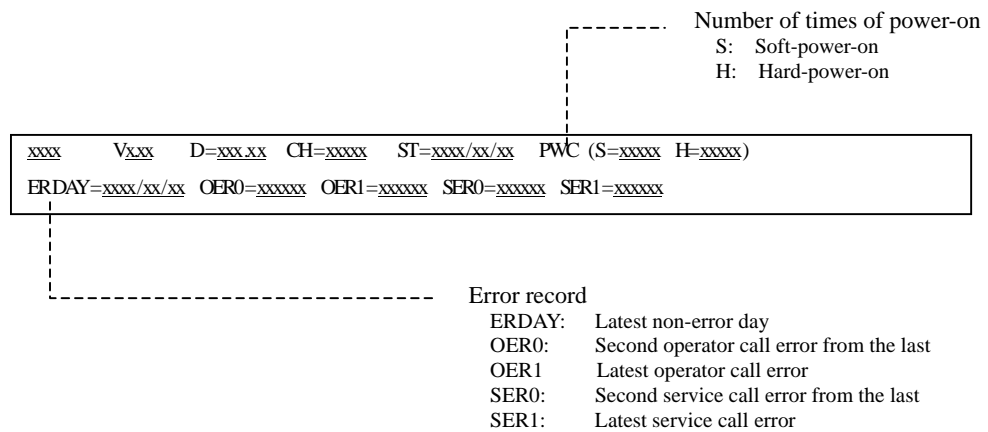

Reference: Model name and destination

Model name	Destination
PIXUS 9900i	JPN
i 9950	EUR /ASA HVT / AU / GB / TW / HK / CN / EUM
i 9900	US / CA / LAM LVT / LAM HVT / KR

<Print check items>

On the service test print (sample on the following page), confirm the following items:

- Check 1, nozzle check pattern: Ink shall be ejected from all nozzles.
- Check 2, top of form accuracy: The line shall not extend off the paper.
- Check 3, vertical straight lines: The line shall not broken.
- Check 4, halftone: There shall be no remarkable streaks or unevenness.
- Check 5, CD-R/automatic print head alignment sensor correction: The results shall be OK.
- Check 6, media sensor correction: Nothing shall be printed to indicate that the correction has been implemented.
(If not implemented, "MEDIA SENSOR = NO CALIBRATE" is printed.)

<Service test print sample>

Check 2:
Top of form accuracy

PIXUS 9900i V1.01 D=000.00 CH=00004 ST=2004/01/13 PWC(S=00071 H=00018)
ERDAY=2004/01/13 OER0=01300 OER1=01401 SER0=05110 SER1=05110

Check 3:
Straight lines

Check 1
Nozzle check
pattern

Check 4
Halftone

PIXUS 9900i

CDR SENSOR=OK

Check 5
(Result of CD-R/automatic print head alignment sensor correction)

Check 6
(Media sensor correction: implemented or not implemented)

(2) EEPROM information print

<How to read the EEPROM information print>

Print sample:

(1)PIXUS 9900i (2)V1.02 (3)CN(USB1=1 USB2=0 1394=0) (4)USB=(200655) (5)D=004.50% (6)ST=2001/09/27
(7)SV(5100/5300) OP(01001/01615) (8)LPD=2002/06/11 (9)LPT=2002/06/11-10:25
(10)PC(M=000 R=004 5D=004 20D=004 CO=004 D=000 C=000) (11)CH=00006 (12)CT(PM=000 R=000
BK=001 G=000 PC=001 C=001 M=001 Y=000) (13)PWC(S=00015 H=010 AP=000) (14)WP=00022
(15)LSD=00021 (16)PAGE(All=00717 PP=00223 HR=00150 PR=00061 SP=00032 MP=00042
PC=00189) (17)EDGE(A3=00000 PC=00000 OTHER=00000) (18)L=00064 2L=00030
A3=00001 (19)CDR=00020 (20)CDPAGE(A4=00020 L=00003 PC=00001 OTHER=00003)
(21)MSPAGE(G1=00022 G2=00051 G3=00032 G4=00026) (22)CDIN=00004
(23)UR(PMe=00 PMo=+04 Re=00 Ro=+04 BK1e=00 BK1o=+04 Ge=00 Go=+04 PCe=00
PCo=+00 C2e=00 C2o=+02 M2e=00 M2o=00 Ye=00 Yo=00 M1e=00 M1o=+03 C1e=-04
C1o=-04) (24)REG(MN=0 AT=1 MG=1) (25)APON=0 (26)APOFF=002
(27)DIRREG(PM=-01 R=-01 BK=+01 G=-01 PC=+02 C2=+01 M2=+02 Y= 00 M1=+01 C1= 00)
(28)DC(PM=-01 R=-01 BK=+01 G=-01 PC=+02 C2=+01 M2=+02 Y= 00 M1=+01 C1= 00)
(29)CDR=(-00198,-00175) (30)CDRS=(00021) (31)MSWS=(1 334 329) (32)MSPP=(1 653 320) (33)MeSNS=1
(34)IC(PM=1 R=1 BK=1 G=0 PC=1 C=0 M=1 Y=1) (35)PD=00 (36)FF(3F 2F 3F) (37)FCT_DIR(+1)

HDEEPROM

(38)V0001
(39)SN=02910000 (40)LN(00000 00000 00000 00003 00013 00017 6729f) (41)ID=00
(42)CLR(PM- BK = 000 PM-G= 000 PM-PC=+000 PM-C2=+000 PM-M2=+000 PM-Y= 000
PM-M1=+000 PM-C1= 000) (43)DIR1= 000 DIR2= 000
EOR(PM= 00 R= 00 BK=00 G= 00 PC= 00 C2= 00 M2= 00 Y= 00 M1= 00 C1= 00)
(44)NG(PMe=0000 PMo=0000 Re=0000 Ro=0000 BK1e=0000 BK1o=0000 Ge=0000 Go=0000)
(PCe=0000 PCo=0000 C2e=0000 C2o=0000 M2e=0000 M2o=0000 Ye=0000 Yo=0000)
(M1e=0000 M1o=0000 C1e=0000 C1o=0000)
(45)DS(PM= 00 R= 00 BK= 00 G= 00 PC= 00 C2= 00 M2= 00 Y= 00 M1= 00 C1= 00)
(46)PTH(PM=000 R=000 BK=000 G=000 PC=000 C2=000 M2=000 Y=000 M1=000 C1=000)

Printed items:

- | | |
|---|---|
| (1) Model name | |
| (2) ROM version | V (x. xx) |
| (3) Connected I/F (USB/USB2.0Hi/1394) | CN (USB1= , USB2= , 1394=) |
| (4) USB S/No | USB (xxxxxx) |
| (5) Waste ink amount | D=xxx.xx% |
| (6) Installation date | ST=xxxx/xx/xx |
| (7) Service call error record (last record, second from the last record) | SV(xxxxx/xxxxx) |
| Operator call error record (last record, second from the last record) | OP (xxxxx/xxxxx) |
| *If there are the same error codes in a row, do not overwrite them. | |
| (8) Last printing day | LPD=xxxx/xx/ xx |
| (9) Last purging time | LPT=xxxx/xx/xx-xx:xx |
| (10) Purging count (manual/deep/5-day/20-day timer/cap opening accumulated time/dot count/cap opening accumulated time) | PC (M=xxx R=xxx 5D=xxx 20D=xxx CO=xxx D=xxx
C=xxx) |
| (11) Print head installation and removal (Change Head) count | CH=xxxxx |
| (12) Ink tank installation and removal (Change Tank) count (PM/R/BK/G/PC/C/M/Y) | CT (PM=xxx R=xxx BK=xxx G=xxx PC=xxx C=xxx
M=xxx Y=xxx) |
| (13) Power-on count (soft/hard/auto power on) | PWC(S=xxxxx H=xxx AP=xxx) |
| (14) Wiping count | WP=xxxxx |
| (15) Number of the largest printing intermission in days (Last Stop Day) | LSD=xxxxx |
| (16) Number of print pages (total/plain paper/high resolution paper/Photo Paper Pro/Photo Paper Plus Glossy/Matte Photo Paper/Card/Other) | PAGE (All=xxxxx PP=xxxxx HR=xxxxx PR=xxxxx
SP=xxxxx MP=xxxxx PC=xxxxx) |
| (17) Number of borderless print pages (A3/A3+, L/4" x 6", and other) | EDGE (A3=xxxxx PC=xxxxx OTHER=xxxxx) |
| (18) Number of print pages | L/4" x 6" L=xxxxx
2L/5" x 7" 2L=xxxxx
A3/A3+ A3=xxxxx |
| (19) Number of CD-Rs printed | CDR=xxxxx |
| (20) Number of Camera Direct Print pages (A4, L/4" x 6", card, other) | CDPAGE (A4=xxxxx L=xxxxx PC=xxxxx) |

(21) Number of print pages using media sensor	OTHER=xxxxx) MSPAGE (G1=xxxxx G2=xxxxx G3=xxxxx G4=xxxxx)
(22) Camera direct print port connection and removal count	CDIN=xxxxx
(23) User print head alignment values	UR(PMe=xx PMo=xx Re=xx Ro=xx BKle= xx BKlo= xx Ge= xx Go= xx PCe= xx PCo= xx C2e= xx C2o= xx M2e= xx M2o= xx Ye =xx Yo= xx M1e= xx M1o= xx C1e= xx C1o= xx)
(24) Print head alignment implementation (manual/auto/simple)	REG (MN=x AT=x MG=x)
(25) Number of automatic powered on	APON=x
(26) Number of automatic powered off	APOFF=xxx
(27) Bidirectional print head alignment	DIRREG(PM=xxx R=xxx BK=xxx G=xxx PC=xxx C2=xxx M2=xxx Y=xxx M1=xx C1=xx)
(28) Dot count	DC(PM=xxx R=xxx BK=xxx G=xxx PC=xxx C2=xxx M2=xxx Y=xxxM1=xxx C1=xxx)
(29) CD-R print position adjustment value	CDR (xxxxx, xxxxx)
(30) CD-R sensor correction value	CDRS=(xxxxx)
(31) Media sensor correction white reference paper (implemented/reflection light/diffusion light)	MSWS=(x xxx xxx)
(32) Plain paper (implemented/reflection light/diffusion light)	MSPP=(x xxx xxx)
(33) Media sensor enabled/disabled	MeSNS=x (1 or 0)
(34) Raw ink presence	IC(PM=x R=x BK=x G=x PC=x C=x M=x Y=x)
(35) Number of page delay	PD=xx
(36) Line inspection information	FF(xx xx xx)
(37) Registration alignment value at factory shipment	FCT_DIR (x)
HEAD EEPROM	
(38) Version	Vxxxxx
(39) Serial number	SN=xxxxxxxx
(40) Lot number	LN=(xxxxx xxxxx xxxxx xxxxx xxxxx xxxxx xxxxx)
(41) Print head ID	ID=xx
(42) Print head alignment value among colors	CLR (PM-BK= xxx PM-G= xxx PM-PC= xxx PM-C2= xxx PM-M2= xxx PM-Y= xxx PM-M1= xxx PM-C1= xxx)
(43) Bidirectional print head alignment value	DIR1= xxx DIR2= xxx
(44) Number of unusable nozzles	UR(PMe=xx PMo=xx Re=xx Ro=xx BKle= xx BKlo= xx Ge= xx Go= xx PCe= xx PCo= xx C2e= xx C2o= xx M2e= xx M2o= xx Ye =xx Yo= xx M1e= xx M1o= xx C1e= xx C1 o= xx)
(45) Dot size	DS (PM=xx R=xx BK=xx G=xx PC=xx C2=xx M2=xx Y=xx M1=xx C1=xx)
(46) PTH	PTH (PM=xxx R=xxx BK=xxx G=xxx PC=xxx C2=xxx M2=xxx Y=xxx M1=xxx C1=xxx)

4. PRINTER TRANSPORTATION METHOD

This section describes the procedures for transporting the printer (for returning after repair, etc.).

1. Keep the print head and ink tanks installed in the carriage. (See Caution 1 below.)
2. Turn off the printer to securely lock the carriage in the home position. (When the printer is turned off, the carriage is automatically locked in place.) (See Caution 2 below.)
Confirm that the paper lifting plate of the sheet feeder unit is raised. (See Caution 3 below.)
3. Securely fix the carriage with tape, as shown in the figure below.
The tape should be similar to the polyester tape used at shipment, which is not easily cut, removable, and will not leave adhesive on the unit or remove housing/silkscreening when peeled off.

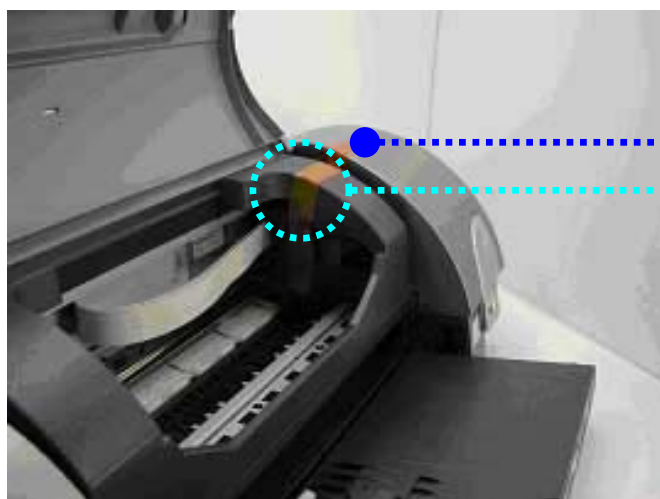

Tape

Securely apply the tape so that it will not easily be removed.

Caution:

1. If the print head is removed from the printer and left alone by itself, ink (especially the green ink) is likely to dry. For this reason, keep the print head installed in the printer, even during transportation.
2. Securely lock the carriage in the home position, to prevent the carriage from moving and applying stress to the carriage flexible cable, or causing ink leakage, during transportation.
3. If the paper lifting plate of the sheet feeder unit is not raised and in the normal usage position (such as when the power is turned off in the user mode) during transportation, the media sensor may be dislocated.

Note:

If the print head must be removed from the printer and transported separately, perform the following:

1. Install the eight color ink tanks (to prevent the nozzles from drying).
2. Attach the protective cap (used when the packing was opened) to the print head (to protect the print head face from damage due to shocks).

Part 2

TECHNICAL REFERENCE

1. NEW TECHNOLOGIES

(1) CD-R feeding mechanism

For the i9950 model, the paper output tray serves as the CD-R tray feeder. (For the i9900 model, the paper output tray serves only its original function, as the model does not support CD-R printing.)

1. How to set the paper output tray when performing CD-R printing.

By pressing the CD-R tray lever down, the paper output tray is raised to the CD-R printing position from the paper printing position.

The sensor attached on the CD-R tray lever mechanism detects each printing position.

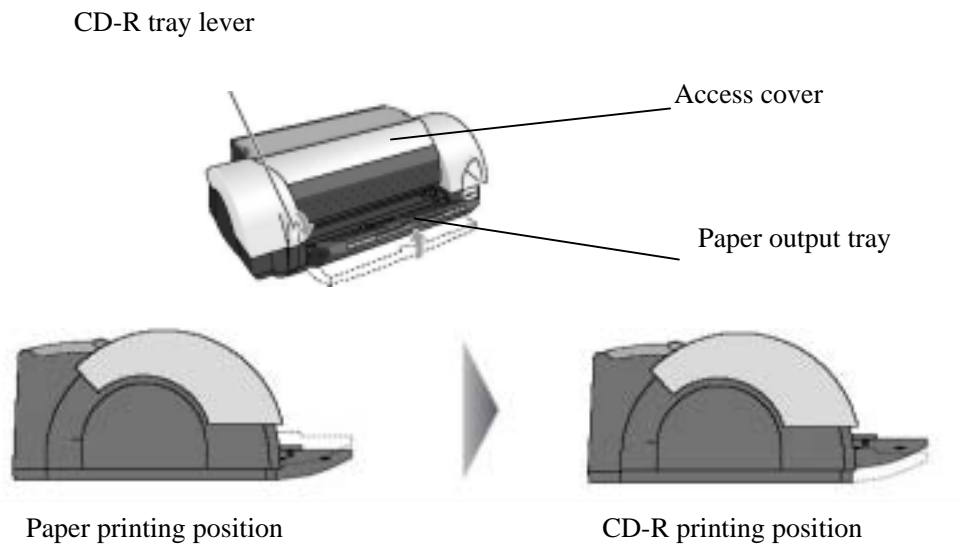

2. How to set the paper output tray when performing paper printing

By lifting the front of the paper output tray up slowly, the paper output tray returns to the paper printing position from the CD-R printing position.



<Expected problems and how to handle them>

Problem	Handling
If the paper output tray is in the CD-R printing position, when the access cover is opened with the printer powered on, the carriage does not move to the center. (Warning indication)	Change the paper output tray to the paper printing position from the CD-R printing position (See above 2.), close the access cover, and open it again.
If the paper output tray is in the CD-R printing position when trying to print to paper, the Power lamp blinks in orange 6 times. (Error indication)	Press the Resume/Cancel button, change the paper output tray to the paper printing position from the CD-R printing position (See above 2.), and perform printing.

(2) Independent cleaning

For i9900/i9950 models, the print head consists of two blocks (C, M, Y and PM, R, BK, G, PC). As a result, it is possible to select either a specific block, or both blocks, for cleaning. For the i9100 model, which has only one block, it was possible only to perform bulk cleaning.

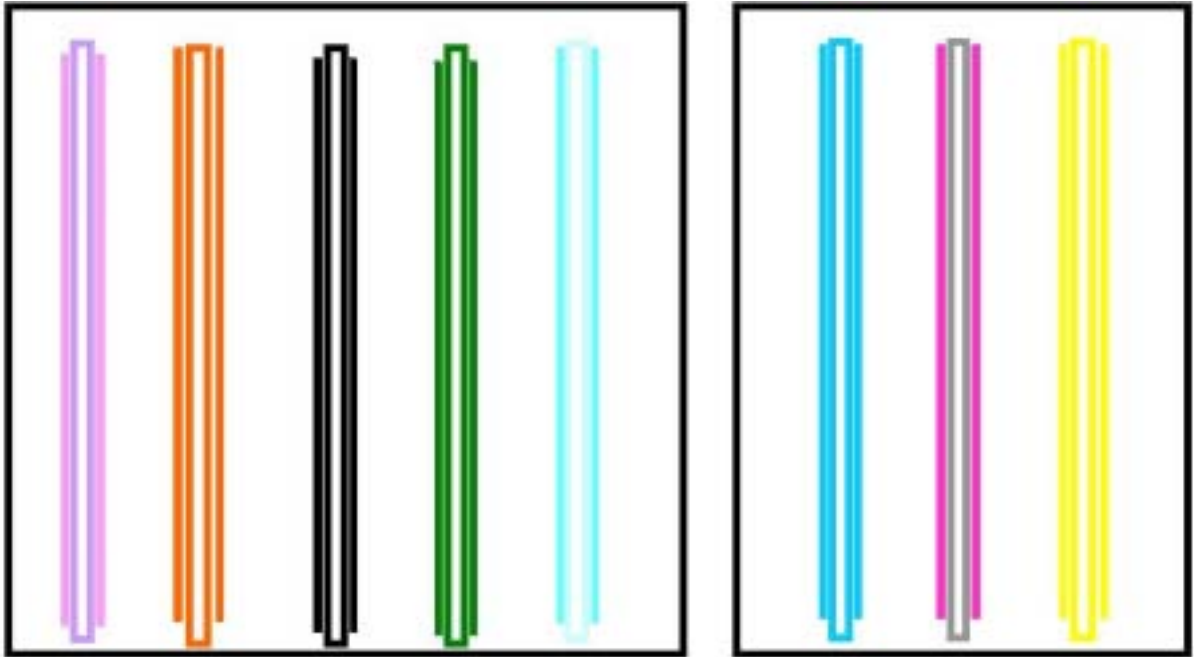

The example print head composition is for the i9900/i9950 model.

The i9900/i9950 print head consists of two blocks with eight colors (PM, R, BK, G, PC and C, M, Y, from left to right).

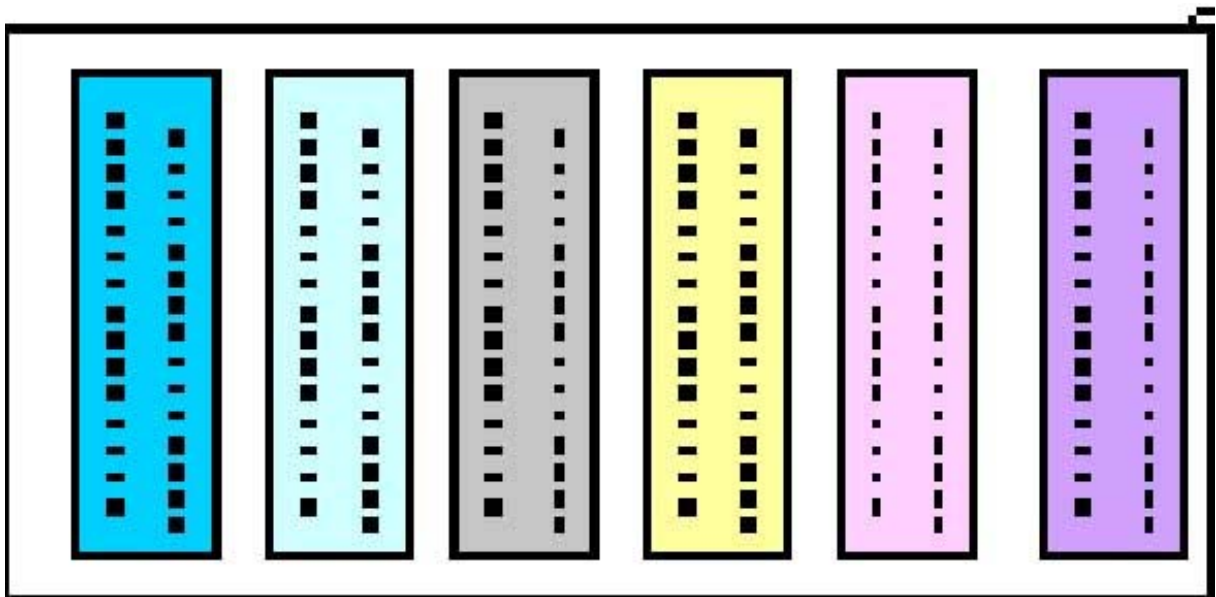

The example print head composition is for the i9100 model.

The i9100 print head consists of one block with six colors (C, PC, BK, Y, PM, and M, from left to right).

2. CLEANING MODE AND AMOUNT OF INK PURGED

To prevent printing problems due to bubbles, dust, or ink clogging, print head cleaning is performed before the start of printing, except in the following cases:

- Cleaning on arrival: Performed when the access cover is closed.
- Cleaning by dot count: Performed after ejection of paper
- Manual cleaning / deep cleaning: Performed manually.

<Cleaning mode list>

Group 1 includes BK/R/G/PC/PM, and Group 2 includes C/M/Y.

Condition	Details	Amount of ink used (g)	Est. required time (sec.)
On arrival of the printer (all colors)	First cleaning after shipment.	3.24 (Group 1) 2.13 (Group 2)	70
Dot count cleaning (all colors / Group 1 / Group 2)* ¹	When the specified number of dots are printed after the previous Group 1 / Group 2 cleaning.		
Timer cleaning - 1 (all colors / Group 1 / Group 2)* ¹	If 120 to 480 hours have elapsed since the previous Group 1 / Group 2 cleaning till the start of the next printing. (The time is counted separately between Group 1 and Group 2.)	0.95 (Group 1) 0.61 (Group 2)	50 (all colors) 50 (Group 1) 50 (Group 2)
Timer cleaning - 2 (all colors / Group 1 / Group 2)* ¹	If 480 hours or more have elapsed since the previous Group 1 / Group 2 cleaning till the start of the next printing.	2.16 (Group 1) 1.42 (Group 2)	70 (all colors) 70 (Group 1) 65 (Group 2)
If the print head has was un-capped at power-on (all colors)			
At ink tank replacement (all colors / Group 1 / Group 2)		1.21 (Group 1) 0.81 (Group 2)	50 (all colors) 50 (Group 1) 50 (Group 2)
At print head replacement (all colors)	When the print head is removed and installed.	3.24 (Group 1) 2.13 (Group 2)	70
Manual cleaning (all colors / Group 1 / Group 2)	- Via the operation panel (all colors only) - Via the printer driver (selectable from Group 1, Group 2, or all colors)	1.21 (Group 1) 0.81 (Group 2)	50 (all colors) 50 (Group 1) 50 (Group 2)
Deep cleaning (all colors / Group 1 / Group 2)	- Via the printer driver (selectable from Group 1, Group 2, or all colors)	2.16 (Group 1) 1.42 (Group 2)	70 (all colors) 70 (Group 1) 65 (Group 2)

*¹ Timer counting is conducted separately for each Group 1 and Group 2 since the previous cleaning, and cleaning is performed. Therefore, it is possible that the cleaning mode differs between Group 1 and Group 2.

3. PRINT MODE

3.1 Resolution

(1) Standard color printing

Paper type	Custom setting value in driver UI	High speed 5	<- 4	3	-> 2	High quality 1
Plain paper, Envelope	Print quality	Custom Fast	Draft	Standard		Custom Fine
	Resolution HxV (dpi)	600×1200	600×1200	2400×1200		2400×2400
	Print control Ink	1 pass, bidirectional 4 colors	1 pass, bidirectional 4 colors	2 passes, bi/unidirectional 4 colors		8 passes, bidirectional 6 colors
Photo Paper Pro	Print quality				High	Custom Fine
	Resolution HxV (dpi)				2400×1200	4800×2400
	Print control Ink				4 passes, bidirectional 8 colors	8 passes, bidirectional 8 colors
Photo Paper Plus Glossy	Print quality		Draft			High
	Resolution HxV (dpi)		1200×1200			4800×2400
	Print control Ink		3 passes, bidirectional 6 colors			8 passes, bidirectional 8 colors
Matte Photo Paper	Print quality			Standard		Custom Fine
	Resolution HxV (dpi)			2400×1200		2400×2400
	Print control Ink			4 passes, unidirectional 7 colors		8 passes, bidirectional 7 colors
Glossy Paper	Print quality		Draft			High
	Resolution HxV (dpi)		2400×1200			4800×2400
	Print control Ink		4 passes, bidirectional 6 colors			8 passes, bidirectional 8 colors
High Resolution Paper	Print quality			Custom Fast	Standard	High
	Resolution HxV (dpi)			2400×1200	2400×1200	2400×2400
	Print control Ink			4 passes, bidirectional 6 colors	4 passes, unidirectional 6 colors	8 passes, bidirectional 6 colors
T-Shirt Transfers	Print quality			Standard		
	Resolution HxV (dpi)			2400×1200		
	Print control Ink			8 passes, bidirectional 4 colors		
Transparencies	Print quality		Draft	Standard		
	Resolution HxV (dpi)		2400×1200	2400×1200		
	Print control Ink		4 passes, bidirectional 4 colors	8 passes, bidirectional 4 colors		
CD-R (recommended) CD-R (non-recommended)	Print quality		Draft	Standard		
	Resolution HxV (dpi)		2400×1200	2400×1200		
	Print control Ink		4 passes, bidirectional 6 colors	8 passes, bidirectional 6 colors		
Other Photo Paper	Print quality			Standard		
	Resolution HxV (dpi)			2400×1200		
	Print control Ink			8 passes, bidirectional 6 colors		

Blue characters: Default setting

Yellow frames: Selectable, even if Custom is not selected in the driver UI.

Ink: 8 colors (BCI-6BK/Y/M/C/PM/PC/R/G)

7 colors (BCI-6BK/Y/M/C/PM/PC/R)

6 colors (BCI-6BK/Y/M/C/PM/PC)

4 colors (BCI-6BK/Y/M/C)

(2) Standard gray scale printing (Paper types different than those for color printing only are listed.)

Paper type	Custom setting value in driver UI	High speed 5	<- 4	3	-> 2	High quality 1
Plain paper	Print quality Resolution HxV (dpi) Print control Ink	Custom Fast 600×1200 1 pass, bidirectional 1 color	Draft 600×1200 1 pass, bidirectional 1 color	Standard 2400×1200 2 passes, bi/unidirectional 4 colors		Custom Fine 2400×2400 8 passes, bidirectional 6 colors
Photo Paper Pro	Print quality Resolution HxV (dpi) Print control Ink				High 2400×1200 8 passes, unidirectional 3 colors	Custom Fine 2400×1200 8 passes, unidirectional 3 colors
Photo Paper Plus Glossy	Print quality Resolution HxV (dpi) Print control Ink		Draft 2400×1200 8 pass, unidirectional 3 colors			High 2400×1200 8 passes, unidirectional 3 colors
Matte Photo Paper	Print quality Resolution HxV (dpi) Print control Ink			Standard 2400×1200 8 passes, unidirectional 3 colors		High 2400×1200 8 passes, unidirectional 3 colors
Envelope	Print quality Resolution HxV (dpi) Print control Ink	Custom Fast 600×1200 1 pass, bidirectional 1 color	Draft 600×1200 1 pass, bidirectional 1 color	Standard 2400×1200 2 passes, bi/unidirectional 4 colors		Custom Fine 2400×2400 8 passes, bidirectional 6 colors
Other Photo Paper	Print quality Resolution HxV (dpi) Print control Ink			Standard 2400×1200 2 passes, bi/unidirectional 3 colors		

Blue characters: Default setting

Yellow frames: Selectable, even if Custom is not selected in the driver UI.

Ink: 6 colors (BCI-6BK/Y/M/C/PM/PC)

4 colors (BCI-6BK/Y/M/C)

3 colors: SP paper, BCI-6BK/Y/C, PR, and MP paper, BCI-6BK/Y/M)

1 color (BCI-6BK)

(3) Borderless printing

Paper type	Custom setting value in driver UI	High speed 5	<- 4	3	-> 2	High quality 1
Plain paper	Print quality Resolution HxV (dpi) Print control Ink			Standard 2400×1200 2 passes, bi/unidirectional 4 colors		
Photo Paper Pro	Print quality Resolution HxV (dpi) Print control Ink				High 2400×1200 4 passes, bidirectional 8 colors	Custom Fine 4800×2400 8 passes, bidirectional 8 colors
Photo Paper Plus Glossy	Print quality Resolution HxV (dpi) Print control Ink		Draft 1200×1200 3 passes, bidirectional 6 colors			High 4800×2400 8 passes, bidirectional 8 colors
Matte Photo Paper	Print quality Resolution HxV (dpi) Print control Ink			Standard 2400×1200 4 passes, unidirectional 7 colors		High 2400×2400 8 passes, bidirectional 7 colors
Glossy Paper	Print quality Resolution HxV (dpi) Print control Ink		Draft 2400×1200 4 passes, bidirectional 6 colors			High 4800×2400 8 passes, bidirectional 8 colors
Other Photo Paper	Print quality Resolution HxV (dpi) Print control Ink			Standard 2400×1200 8 passes, bidirectional 6 colors		

Blue characters: Default setting
 Yellow frames: Selectable, even if Custom is not selected in the driver UI.
 Ink: 8 colors (BCI-6BK/Y/M/C/PM/PC/R/G)
 7 colors (BCI-6BK/Y/M/C/PM/PC/R)
 6 colors (BCI-6BK/Y/C/PM/PC)
 4 colors (BCI-6BK/Y/M/C)

(4) Duplex printing

Paper type	Custom setting value in driver UI	High speed 5	<- 4	3	-> 2	High quality 1
Plain paper	Print quality Resolution HxV (dpi) Print control Ink	Custom Fast 600×1200 1 pass, bidirectional 4 colors	Draft 600×1200 1 pass, bidirectional 4 colors	Standard 2400×1200 2 passes, bi/unidirectional 4 colors		Custom Fine 2400×2400 8 passes, bidirectional 4 colors

Blue characters: Default setting
 Yellow frames: Selectable, even if Custom is not selected in the driver UI.
 Ink: 4 colors (BCI-6BK/Y/M/C)

(5) Camera Direct Printing

PictBridge supporting mode

Paper type	Custom setting value in driver UI	High speed 5	<- 4	3	-> 2	High quality 1
Photo Paper Pro (Fast Photo)	Print quality Resolution HxV (dpi) Print control Ink					High 4800×2400 8 passes, bidirectional 8 colors
Photo Paper Plus Glossy (Photo / Default)	Print quality Resolution HxV (dpi) Print control Ink					High 4800×2400 8 passes, bidirectional 8 colors

Bubble Jet Direct supporting mode

Paper type	Custom setting value in driver UI	High speed 5	<- 4	3	-> 2	High quality 1
Photo Paper Pro (Card #1, #2, #3, #4, A4, LTR)	Print quality Resolution HxV (dpi) Print control Ink					High 4800×2400 8 passes, bidirectional 8 colors
Photo Paper Plus Glossy (A4, LTR)	Print quality Resolution HxV (dpi) Print control Ink					High 4800×2400 8 passes, bidirectional 8 colors

Ink: 8 colors (BCI-6BK/Y/M/C/PM/PC/R/G)

4. FAQ (Specific Problems and Solutions)

No.	Occurrence level*	Function	Symptom	Condition	Cause	Solution	Possible call or complaint
1	B	Print results	Depending on print density, black streaks with 4 mm pitch or faint white streaks with 1-2 mm pitch may appear in gray-scale printing.	- Printing with gray-scale.	Due to changes in the gray-scale process specifications, streaks appear if the ink amount ejected from the print head is small.	1. Change the original images into gray mode with application (ZoomBrowser or Photoshop). Print not selecting gray scale printing. However color is tinged with red or blue a little. 2. ROMVerUp (->1.03 or more)	-Streaks appear.
2	B	Print results	Green ink is not ejected.	- After the printer has not been used for more than one week. - Under high temperature and low humidity circumstances.	Green ink is clogged, as it has not been used for a long time.	- Perform print head deep cleaning. - Leave the print head untouched with the print head capped overnight.	- Color appears abnormal. (The same phenomenon as non-ejection of ink, in general)
3	B	Print results	The back side of paper is smeared in borderless printing.	- When print patterns with high duty are often printed.	Ink mist generated during printing or cleaning adheres on the rib of the platen.	Clean the inside of the printer. (Wipe the platen ribs with wet cloth.)	The back side of paper is smeared.

* Occurrence level:

A: The symptom is likely to occur frequently. (Caution required)

B: The symptom may occur under certain conditions, but likeliness is assumed very low in practical usage.

C: The symptom is unlikely to be recognized by the user, and no practical issues are assumed.

5. SPECIFICATIONS

5.1 Printer Specifications

Type	Desktop serial color bubble jet printer				
Paper feeding method	Auto sheet feed (ASF) Front loading (CD-R printing only) ^{*1}				
Resolution	4,800 dpi x 2,400 dpi (Max.)				
Throughput			Draft	Standard	
	Black (New Black)		16 ppm	4.4 ppm	
	Color (New Color)		12 ppm	4.2 ppm	
	Photo (SCID N5 8"x10")			1.19 ppm (PR-101 A4 sized paper)	
Printing direction	Bidirectional, uni-directional				
Print width	Max. 322.0 mm (329.0 mm in borderless printing)				
Interface	USB 2.0 High Speed, USB 2.0 Full Speed, FireWire (only for Mac)				
ASF stacking capacity	Plain paper (65 g/m ²): Max. 13 mm (Approx. 150 sheets)				
Paper weight	64 to 105 g/m ²				
Detection functions	<ul style="list-style-type: none"> - Cover open - Remaining ink amount (optical / dot count) - Paper out - Waste ink amount - Pick-up roller - Carriage position - Paper type - Paper output tray position 		<ul style="list-style-type: none"> - Presence of print head - Printing position - Paper end sensor - Internal temperature - Paper feed roller position - Head-to-paper distance - Camera direct printing device - Presence of CD-R*1 		
Acoustic noise	Approx. 37 dB (without optional devices, Photo Paper Pro / fine mode)				
Environmental requirements	During operation	Temperature	5C to 35C (41F to 95F)		
		Humidity	10%RH to 90%RH (no condensation)		
	Non operation	Temperature	0C to 40C (32F to 104F)		
		Humidity	5%RH to 95%RH (no condensation)		
Power supply	Power supply voltage	Frequency	Power consumption	Standby	Power-off
	AC 100 to 127 V	50/60 Hz	Approx. 28 W	Approx. 2 W	Approx. 1 W
	AC 220 to 240 V	50/60 Hz	Approx. 28 W	Approx. 2 W	Approx. 1 W
External dimensions	Printer alone:				
	With paper rest and output tray retracted:		Approx. 577 (W) x 334 (D) x 182 (H) mm		
Weight	Approx. 9.5 kg, not including print head				
Related standards (Proposed) (Printer, Adapter)	Electromagnetic radiance:				
	VCCI, FCC, IC, C-tick, Taiwan EMC, Korea EMC, CCIB, CCEE				
	Electrical safety:				
	Electrical Appliance and Material Safety Law (DENAN), UL, C-UL, CB Report, GS, CE Mark, FIMKO, CCIB (EMC), AS, CCEE, PSB, Electrical Safety Regulations of Korea, SASO				
	Environmental regulations:				
	Energy Star, Blue Angel, Environment Label				
Serial number location	On the chassis (visible to the right of the flexible cable holder when the access cover is open)				
Remaining ink amount detection	Available (automatic detection by optical method and dot count, enabled at default)				
Paper type detection	Available (automatic detection of paper type, only with default driver settings (plain paper / standard print quality), enabled at default)				
Print head alignment	Available (simplified manual alignment via driver utilities, or automatic alignment via Resume / Cancel button operation)				

*1: Only for CD-R printing supported regions

5.2 Print Head Specifications

	Print head
Type	Single head with 8 removable ink tanks (each color)
Print head	768 nozzles in 2 vertical lines (1,200 dpi) for each color 2 pl ink droplet for all nozzles
Ink color	Dye-based black, cyan, magenta, yellow, photo cyan, photo magenta, red, green
Ink tank	BCI-6 BK/C/M/Y/PC/PM/R/G (dye-based)
Weight (Net)	Print head: approx.100 g (not including ink tanks, protective and packaging materials)
Supply method	As a service part (not including ink tanks)
Part number	QY6-0055-000

Note: This print head is usable only for the PIXUS 9900i/i9900/i9950.

5.3 Comparison with PIXUS 9100i / i9100

Printer specifications

		i9900/i9950	i9100
Ink		BK, C, M, Y, PC, PM, R, and G (8 colors)	BK, C, M, Y, PC, and PM (6 colors)
Number of print head nozzles		768 x 8	512 x 6
Ink drop size		2pl	4pl
Maximum vertical resolution		4800 (H) x 2400 (V) dpi	4800 (H) x 1200 (V) dpi
Interface		USB USB2.0Hi (WinXP / 2K, Mac OS X10.2.7 or later) IEEE1394 (For only Mac)	USB IEEE1394 (WinXP / 2K / Me, Mac 9.0.4 – 9.x, O S X 10.2.1 or later)
CD-R printing		Yes (except for i9900)	No
Paper thickness lever		No	Yes
Automatic register adjustment sensor		Yes	No
Media sensor		Yes	No
Camera direct printing		PictBridge Canon digital camera: Printing is possible on paper up to A3+ size. Non-Canon digital camera: Printing is possible on paper up to A3 size.	No
		BubbleJetDirect	
Number of printable pages	1500 characters per page	740 pages	590 pages
	Color (ISO JIS-SCID No. 5)	BK 1100 pages / C 1100 pages / M 790 pages / Y 540 pages / PC 380 pages / PM 280 pages / R 2300 pages / G 2300 pages	BK 990 / pages C 860 pages / M 790 pages / Y 470 pages / PC 410 pages / PM 270 pages

Service specifications

		i9900/i9950	i9100
	Service print head number	QY6-0055	QY6-0039
*Full waste ink error	The number of pages	15.75 k pages	10 k pages
	Period	3.75 years	2.4 years
Service mode	Service print pattern	A4 (vertical)	A3 (Possible to be printed on A4 sized paper (horizontal))
Service mode	On EEPROM information printing (the number of A3/A3+ pages passed is displayed.)	Yes	No
Serviceability	ROM version up	Due to flash ROM, possible to rewrite using tool.	Due to mask ROM use, exchange at the board level.

* Under normal use condition for the A3 model, calculated with 21k pages/5 years.

Part 3
APPENDIX

1. BLOCK DIAGRAM

K10238 Block Diagram

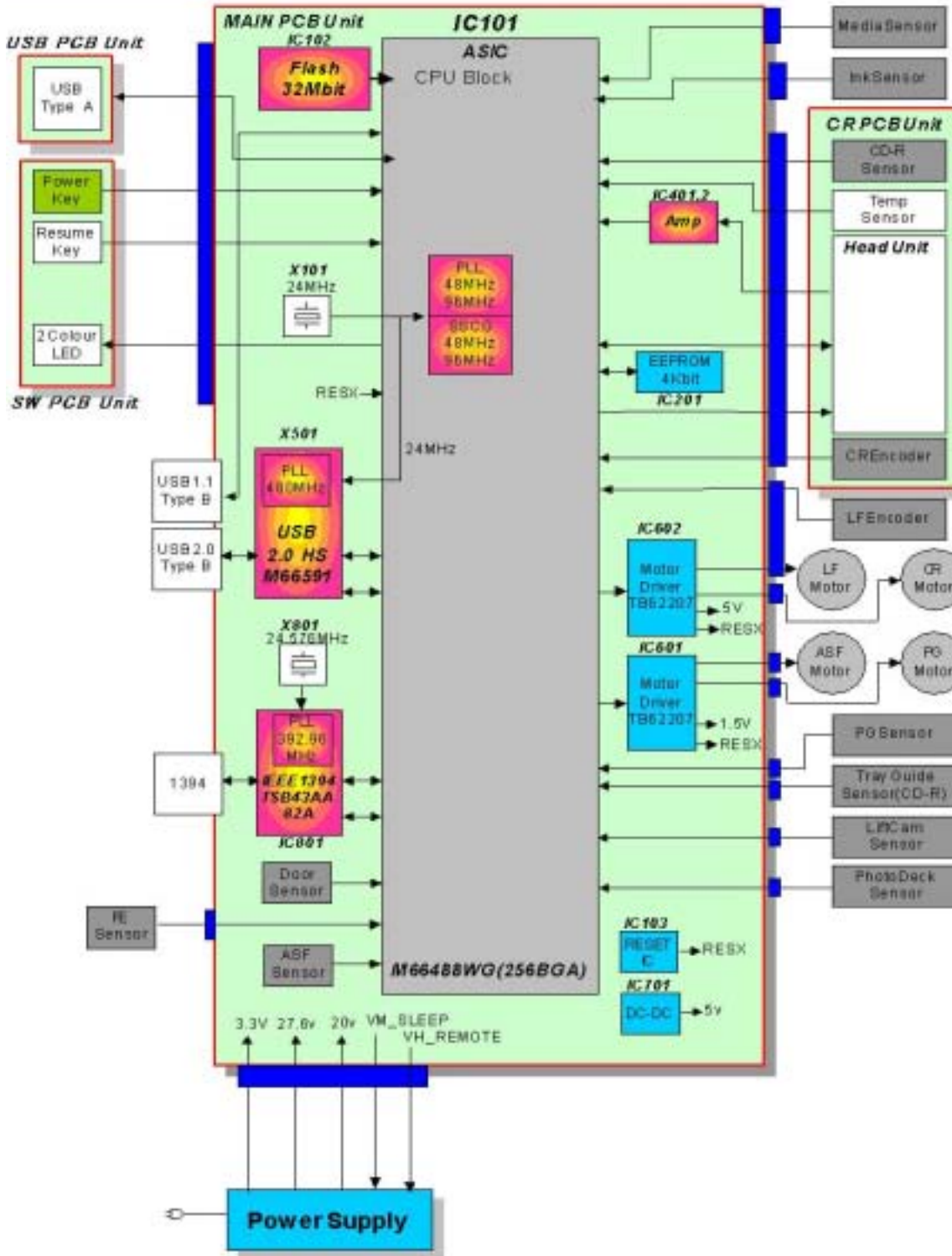

Remarks : Indicate PCB Unit
 : Indicate Connector

2. CONNECTOR LOCATION AND PIN LAYOUT

2.1 Logic Board Ass'y

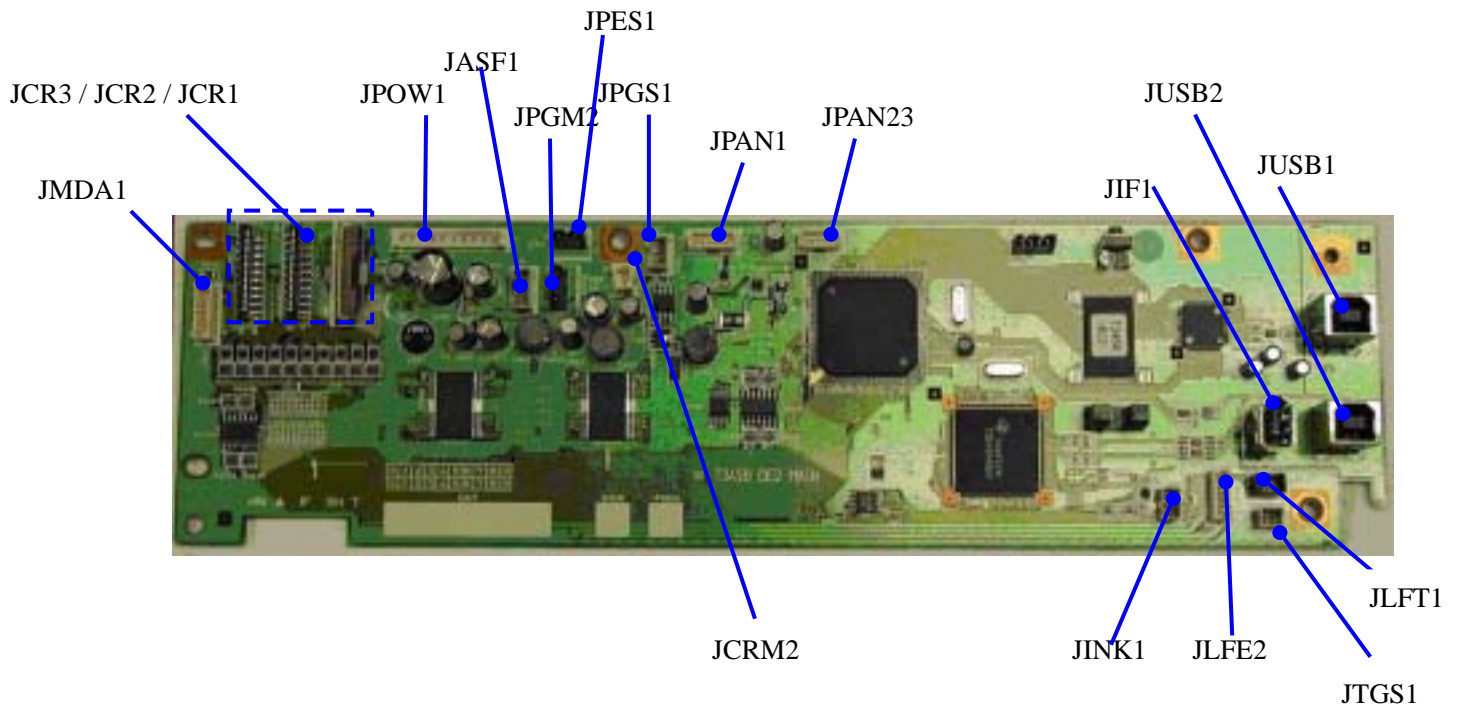

JCR1 (Print Head 1/3 [Carriage Unit])

No.	Signal name	Function	Input/Output
1	GND	GND	-
2	ENCA	CR encoder phase A	In
3	WIDTH	CDR sensor signal	In
4	ENCB	CR encoder phase B	In
5	EEPSK	Head EEPROM serial clock signal	Out
6	EEPDI	Head EEPROM data signal	Bus
7	SNPOW	Encoder power supply 3.3 V	Out
8	VDD	Head logic drive power supply 3.3V	Out
9	EEPCS	Head EEPROM chip select signal	Out
10	CLK	Head data transmission clock signal	Out
11	AD_TH	Thermistor signal	In
12	DIA0	Diode sensor anode 0	In
13	LT	Transmission clock clutch signal	Out
14	DIA1	Diode sensor anode 1	In
15	HE89	Heat enable M1, C1	Out
16	HE7	Heat enable Y	Out
17	HE56	Heat enable C2, M2	Out
18	DATA15	Data Y odd	Out
19	DATA19	Data C1 odd	Out
20	DATA18	Data C1 even	Out
21	DATA17	Data M1 odd	Out
22	DATA16	Data M1 even	Out
23	DATA14	Data Y even	Out
24	DATA12	Data M2 even	Out
25	DATA10	Data C2 even	Out
26	DATA13	Data M2 odd	Out
27	DATA11	Data C2 odd	Out
28	DATA4	Data BK even	Out
29	DATA0	Data PM even	Out
30	DATA9	Data PC odd	Out
31	DATA8	Data PC even	Out
32	DATA1	Data PM odd	Out
33	DATA2	Data R even	Out
34	HE2	Heat enable G, PC	Out
35	DATA5	Data BK odd	Out
36	HE34	Heat enable BK	Out
37	HE01	Heat enable PM, R	Out
38	DATA7	Data G odd	Out
39	DATA6	Data G even	Out
40	DATA3	Data R odd	Out

JCR2 (Print Head 2/3 [Carriage Unit])

No.	Signal name	Function	Input/Output
1 to 8	GNDH1	GND	-
9	CDRPOW	CDR sensor power supply	Out
10	JIA3	Diode sensor anode 3	In
11	GND	GND	-
12	VHT	Head drive power supply 20V	Out
13 to 20	VH1	Head drive power supply 20V	Out

JCR3 (Print Head 3/3 [Carriage Unit])

No.	Signal name	Function	Input/Output
1 to 8	VH2	Head drive power supply 20V	Out
9	VDD	Head logic drive power supply 3.3V	Out
10	DIK	Diode sensor cathode	Out
11	DIA2	Diode sensor anode 3	In
12	GND	GND	-
13 to 20	GNDH2	GND	-

JPOW1 (AC Adapter)

No.	Signal name	Function	Input/Output
1, 2	VH	Head power supply	In
3	GND	GND	-
4, 5	VM	Motor power supply	In
6, 7	GND	GND	-
8	VH_REMOTE	VH control signal	Out
9	VM_SLEEP	VM control signal	Out
10	+3.3V	Logic power supply +3.3V	In

JPAN1 (Operation Panel Ass'y)

No.	Signal name	Function	Input/Output
1	+3.3V	Operation panel power supply +3.3V	Out
2	GND	Operation panel GND	-
3	POW_SW	Operation panel Power SW	In
4	RESUME_SW	Operation panel Resume SW	In
5	LED_RES	Operation panel Resume LED drive signal	Out
6	LED_POW	Operation panel Power LED drive signal	Out

JPAN2 (Operation Panel Ass'y)

No.	Signal name	Function	Input/Output
1	FG	DSC-DIRECT GND	-
2	VBUS	DSC-DIRECT VBUS power supply	Out
3	D-	DSC-DIRECT USB: D- signal	Bus
4	D+	DSC-DIRECT USB: D+ signal	Bus
5	GND	DSC-DIRECT GND	-

JUSB1 (USB I/F)

No.	Signal name	Function	Input/Output
1	VBUS	USB: VBUS power supply	Out
2	D-	USB: D- signal	Bus
3	D+	USB: D+ signal	Bus
4	GND	USB: GND	-
5 to 9	GND	GND	-

JUSB2 (USB I/F)

No.	Signal name	Function	Input/Output
1	VBUS	USB: VBUS power supply	Out
2	D-	USB: D- signal	Bus
3	D+	USB: D+ signal	Bus
4	GND	USB: GND	-
5 to 9	GND	GND	-

JIF1 (IEEE1394 I/F)

No.	Signal name	Function	Input/Output
1	VBUS	IEEE1394: VBUS	NC
2	GND	IEEE1394: GND	-
3	TPB1-	IEEE1394: TPB1-signal	Bus
4	TPB1+	IEEE1394: TPB1+signal	Bus
5	TPA1-	IEEE1394: TPA1-signal	Bus
6	TPA1+	IEEE1394: TPA1-signal	Bus

JLFT1 (Lift Cam Sensor [Photo Interrupter])

No.	Signal name	Function	Input/Output
1	VSEN_5V	Sensor power supply 5V	Out
2	GND	GND	-
3	SNS_LIFT_UP	CD-R lift-up sensor signal	In

JINK1 (Ink Sensor [Platen Unit])

No.	Signal name	Function	Input/Output
1	INK_PWM	Ink PWM signal	Out
2	GND	GND	-
3	AD_INK	Ink sensor signal	In

JMDA1 (Media Sensor [Sheet Feeder Unit])

No.	Signal name	Function	Input/Output
1	-	-	-
2	MEDIA_PWM	Media sensor PWM signal	Out
3	GND	GND	-
4	MEDIA1_SNS	Media sensor 1 signal	In
5	MEDIA2_SNS	Media sensor 2 signal	In

JLFE2 (Paper Feed Motor & Timing Sensor Unit)

No.	Signal name	Function	Input/Output
1	LF_L	LF motor +	Out
2	LF_LN	LF motor -	Out
3	GND	GND	-
4	LF_ENCA	LF encoder phase A	In
5	EVDD	LF encoder drive power supply	Out
6	LF_ENCB	LF encoder phase B	In

JCRM2 (Carriage Motor)

No.	Signal name	Function	Input/Output
1	CR_L	CR motor +	Out
2	CR_LN	CR motor -	Out

JPGM2 (Purge Motor [Purge Unit])

No.	Signal name	Function	Input/Output
1	PGA	PG motor phase A+	Out
2	PGB	PG motor phase B+	Out
3	PGA-	PG motor phase A-	Out
4	PGB-	PG motor phase B-	Out

JASFS1 (ASF Motor [Sheet Feeder Unit])

No.	Signal name	Function	Input/Output
1	ASFB-	ASF motor phase B-	Out
2	ASFA-	ASF motor phase A-	Out
3	ASFB	ASF motor phase B+	Out
4	ASFA	ASF motor phase A+	Out

JPGS1 (Purge Sensor [Purge Unit])

No.	Signal name	Function	Input/Output
1	SNS_PG	PURGE sensor signal	Out
2	GND	GND	-
3	VSEN_5V	Sensor power supply 5V	In

JPES1 (PE Sensor)

No.	Signal name	Function	Input/Output
1	VSEN_5V	Sensor power supply 5V	Out
2	GND	GND	-
3	SNS_PE	PE sensor signal	In

JTGS1 (CD-R tray lever switch)

No.	Signal name	Function	Input/Output
1	CDR-TRY-SW	CDR tray lever switch signal	In
2	GND	GND	-

2.2 Carriage Board (print head connection terminals)

No.	Signal name	Function	Input/Output
1 to 3	VH2	Head drive power supply 20V	Out
4	DIA2	Diode sensor anode 2	In
5	EEPDI	Head EEPROM data signal	In
6	EEPDO	Head EEPROM data signal	Out
7	EEPSK	Head EEPROM serial clock signal	Out
8	EEPCS	Head EEPROM chip select signal	Out
9	DATA0	Head data PM even	Out
10	VDD	Head logic drive power supply 3.3V	Out
11	VHT	Head drive power supply 16V (short-circuiting with VH on the logic board)	Out
12, 13	VH1	Head drive power supply 16V	Out
14 to 16	VH2	Head drive power supply 16V	Out
17	DIA3	Diode sensor anode 3	In
18	DATA17	Head data M1 odd	Out
19	DATA14	Head data Y even	Out
20	DATA13	Head data M2 odd	Out
21	DATA4	Head data BK even	Out
22	DIA0	Diode sensor anode 0	In
23	VDD	Head logic drive power supply 3.3V	Out
24 to 26	VH1	Head drive power supply 16V	Out
27	HE89	Heat enable M1, C1	Out
28	HE7	Heat enable Y	Out
29	HE56	Heat enable C2, M2	Out
30	LT	Transmission clock clutch signal	Out
31	DATA15	Head data Y odd	Out
32	DATA16	Head data M1 even	Out
33	DATA11	Head data C2 odd	Out
34	DATA8	Head data PC even	Out
35	DATA1	Head data PM odd	-
36	DIA1	Diode sensor anode 1	In
37	HE34	Heat enable G, PC	Out
38	HE2	Heat enable BK	Out
39	HE01	Heat enable PM, R	Out
40 to 42	GNDH2	Head GND	-
43	DIK	Diode sensor cathode	Out
44	DATA19	Head data C1 odd	Out
45	DATA10	Head data C2 even	Out
46	DATA9	Head data PC odd	Out
47	DATA2	Head data R even	Out
48	DATA5	Head data BK odd	Out
49	VSS	Logic GND	-
50 to 52	GNDH1	Head GND	-
53 to 55	GNDH2	Head GND	-
56	CLK	Head transmission clock	Out
57	DATA18	Head data C1 even	Out
58	DATA12	Head data M2 even	Out
59	DATA7	Head data G odd	Out
60	DATA6	Head data G even	Out
61	DATA3	Head data R odd	Out
62	VSS	Logic GND	-
63 to 65	GNDH1	Head GND	-

PRINTED IN JAPAN (IMPRIME AU JAPON) CANON INC.

Free Manuals Download Website

<http://myh66.com>

<http://usermanuals.us>

<http://www.somanuals.com>

<http://www.4manuals.cc>

<http://www.manual-lib.com>

<http://www.404manual.com>

<http://www.luxmanual.com>

<http://aubethermostatmanual.com>

Golf course search by state

<http://golfingnear.com>

Email search by domain

<http://emailbydomain.com>

Auto manuals search

<http://auto.somanuals.com>

TV manuals search

<http://tv.somanuals.com>