

DIGITAL VIDEO CAMCORDER

Instruction Manual

ENGLISH

E

CAMÉSCOPE ET LECTEUR VIDEO NUMÉRIQUES

Mode d'emploi

FRANÇAIS

F

VIDEOCÁMARA Y GRABADORA DIGITAL

Manual de Instrucciones

ESPAÑOL

Es

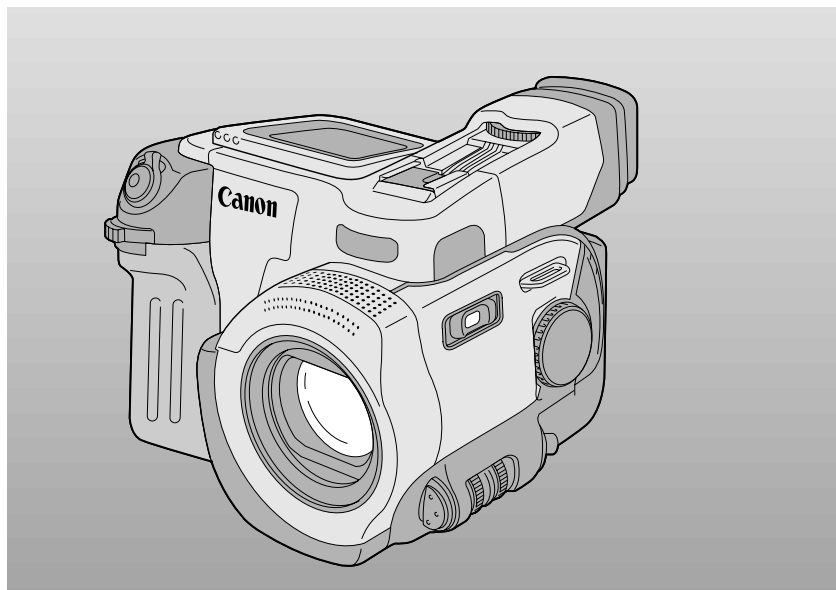

Canon optura

A (NTSC)

Mini DV Digital
Video
Cassette

Important Usage Instructions

E

WARNING:



TO REDUCE THE RISK OF FIRE OR ELECTRIC SHOCK, DO NOT EXPOSE THIS PRODUCT TO RAIN OR MOISTURE.

WARNING:



TO REDUCE THE RISK OF ELECTRIC SHOCK AND TO REDUCE ANNOYING INTERFERENCE, USE THE RECOMMENDED ACCESSORIES ONLY.

COPYRIGHT WARNING:

Unauthorized recording of copyrighted materials may infringe on the rights of copyright owners and be contrary to copyright laws.

Digital Video Camcorder, OPTURA

This device complies with Part 15 of the FCC Rules. Operation is subject to the following two conditions: (1) This device may not cause harmful interference, and (2) this device must accept any interference received, including interference that may cause undesired operation.

Note: This equipment has been tested and found to comply with the limits for class B digital device, pursuant to Part 15 of the FCC Rules. These limits are designed to provide reasonable protection against harmful interference in a residential installation. This equipment generates, uses and can radiate radio frequency energy and, if not installed and used in accordance with the instructions, may cause harmful interference to radio communications. However, there is no guarantee that interference will not occur in a particular installation. If this equipment does cause harmful interference to radio or television reception, which can be determined by turning the equipment off and on, the user is encouraged to try to correct the interference by one or more of the following measures:

- Reorient or relocate the receiving antenna.
- Increase the separation between the equipment and receiver.
- Connect the equipment into an outlet on a circuit different from that to which the receiver is connected.
- Consult the dealer or an experienced radio/TV technician for help.

Use of shielded cable is required to comply with class B limits in Subpart B of Part 15 of FCC Rules. Do not make any changes or modifications to the equipment unless otherwise specified in the manual. If such changes or modifications should be made, you could be required to stop operation of the equipment.

Canon U.S.A. Inc.

One Canon Plaza, Lake Success, NY 11042, U.S.A.

Tel No. (516)328-5600

Introduction

Important Warning



**CAUTION:
TO REDUCE THE RISK OF ELECTRIC SHOCK, DO NOT REMOVE COVER (OR BACK). NO USER SERVICEABLE PARTS INSIDE. REFER SERVICING TO QUALIFIED SERVICE PERSONNEL.**

The lightning flash with arrowhead symbol, within an equilateral triangle, is intended to alert the user to the presence of uninsulated "dangerous voltage" within the product's enclosure, that may be of sufficient magnitude to constitute a risk of electric shock to persons.



The exclamation point, within an equilateral triangle, is intended to alert the user to the presence of important operating and maintenance (servicing) instructions in the literature accompanying the product.

IMPORTANT SAFETY INSTRUCTIONS

E

Introduction

In these safety instructions the word “product” refers to the Canon Digital Video Camcorder OPTURA and all its accessories.

1. Read Instructions — All the safety and operating instructions should be read before the product is operated.
2. Retain Instructions — The safety and operating instructions should be retained for future reference.
3. Heed Warnings — All warnings on the product and in the operating instructions should be adhered to.
4. Follow Instructions — All operating and maintenance instructions should be followed.
5. Cleaning — Unplug this product from the wall outlet before cleaning. Do not use liquid or aerosol cleaners. The product should be cleaned only as recommended in this manual.
6. Accessories — Do not use accessories not recommended in this manual as they may be hazardous.
7. Avoid magnetic or electric fields — Do not use the camera close to TV transmitters, portable communication devices or other sources of electric or magnetic radiation. They may cause picture interference, or permanently damage the camera.
8. Water and Moisture — Hazard of electric shock — Do not use this product near water or in rainy/moist situations.
9. Placing or Moving — Do not place on an unstable cart, stand, tripod, bracket or table. The product may fall, causing serious injury to a child or adult, and serious damage to the product. A product and cart combination should be moved with care. Quick stops, excessive force, and uneven surfaces may cause the product and cart combination to overturn.



10. Power Sources — The CA-900A Compact Power Adapter should be operated only from the type of power source indicated on the marking label. If you are not sure of the type of power supply to your home, consult your product dealer or local power company. Regarding other power sources such as battery power, refer to instructions in this manual.
11. Polarization — The CA-900A Compact Power Adapter is equipped with a polarized 2-prong plug (a plug having one blade wider than the other). The 2-prong polarized plug will fit into the power outlet only one way. This is a safety feature. If you are unable to insert the plug fully into the outlet, try reversing the plug. If the plug still fails to fit, contact your electrician to replace your obsolete outlet. Do not defeat the safety purpose of the polarized plug.
12. Power Cord Protection — Power cords should be routed so that they are not likely to be walked on or pinched by items placed upon or against them. Pay particular attention to plugs and the point from which the cords exit the product.
13. Outdoor Antenna Grounding — If an outside antenna is connected to the product, be sure the antenna is grounded so as to provide some protection against voltage surges and built-up static charges. Section 810 of the National Electrical Code, ANSI / NFPA No. 70—1984, provides information with respect to proper grounding of the mast and supporting structure, grounding of the lead-in wire to an antenna discharge unit, size of grounding conductors, location of antenna discharge unit, connection to grounding electrodes, and requirements for the grounding electrode. See figure 1.

Fig. 1

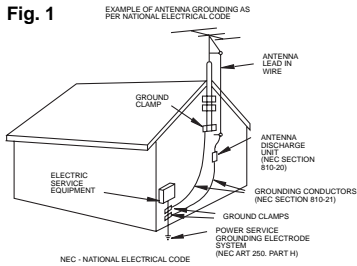

14. **Lightning** — For added protection of this product during a lightning storm, or when it is left unattended and unused for long periods of time, disconnect it from the wall outlet and disconnect the antenna. This will prevent damage to the product due to lightning and power-line surges.
15. **Power Lines** — An outside antenna system should not be located in the vicinity of overhead power lines or other electric light or power circuits, or where it can fall into such power lines or circuits. When installing an outside antenna system, extreme care should be taken to keep from touching such power lines or circuits as contact with them might be fatal.
16. **Overloading** — Do not overload wall outlets and extension cords as this can result in a risk of fire or electric shock.
17. **Objects and Liquid Entry** — Never push objects of any kind into this product through openings as they may touch dangerous voltage points or short out parts that could result in a fire or electric shock. Be careful not to spill liquid of any kind onto the product.
18. **Servicing** — Do not attempt to service this product yourself as opening or removing covers may expose you to dangerous voltage or other hazards. Refer all servicing to qualified service personnel.
19. **Damage Requiring Service** — Disconnect this product from the wall outlet and all power sources including battery, and refer servicing to qualified service personnel under the following conditions:
 - a. When the power-supply cord or plug is damaged.
 - b. If any liquid has been spilled onto, or objects have fallen into, the product.
 - c. If the product has been exposed to rain or water.
 - d. If the product does not operate normally even if you follow the operating instructions. Adjust only those controls that are covered by the operation instructions. Improper adjustment of other controls may result in damage and will often require extensive work by a qualified technician to restore the product to its normal operation.
 - e. If the product has been dropped or the cabinet has been damaged.
 - f. When the product exhibits a distinct change in performance. This indicates a need for service.
20. **Replacement Parts** — When replacement parts are required, be sure the service technician has used replacement parts that are specified by Canon or that have the same characteristics as the original part. Unauthorized substitutions may result in fire, electric shock or other hazards.
21. **Safety Check** — Upon completion of any service or repairs to this product, ask the service technician to perform safety checks to determine that the product is in safe operating order.

Contents

Introduction

Important Usage Instructions	2
Important Safety Instructions	3
Thank you for Choosing a Canon	6
Introducing the OPTURA	7

Mastering the Basics

Powering Your Camcorder	8
Loading a Cassette.....	10
Basic Recording	12
Zooming	14
Using the LCD Screen.....	15
Playing back a Cassette	16
Connections for Playback on a TV Screen	19
Tips for Making Better Videos	22

Using the Full Range of Features

~ General ... ~

Turning the Optical Image Stabilizer On/Off	24
Selecting from the Menus	25
Using the Wireless Controller/Tally Lamp	27

~ For Recording ...~

Setting the Date and Time	29
Displaying Data Code	30
Taking Still Pictures (Photo Mode)	31
Searching Through Your Recorded “Photos” (Photo Search)	32

Changing the Movie Mode (Normal/Progressive Scan)	33
Searching and Reviewing While Recording.....	34
Using the Various Recording Programs	35
Fading In and Out Between Scenes.....	40
Audio Recording	43
Setting the Self-Timer	44
Using a Canon Speedlite for Flash Photography (optional accessory)	45

~ When Making Manual Adjustments ...~

Adjusting Exposure Manually	46
Adjusting Focus Manually	47
Setting the White Balance	49
Editing to a VCR	51

Additional Information

Preparing the Camera	54
Notes on Using the Batteries	55
Setting the Audio Output.....	58
Maintenance.....	59
Troubleshooting	62
The OPTURA System Diagram	65
Optional Accessories	66
Finding Your Way Around the OPTURA	70
Screen Displays	73
Specifications.....	77
Index	78

The serial number of this product may be found on the bottom of the camera. No others have the same serial number as yours. You should record the number and other vital information here and retain this book as a permanent record of your purchase to aid identification in case of theft.

Date of Purchase
Dealer Purchased From
Dealer Address
Dealer Phone No.
Model Name OPTURA
Serial No.

Thank you for choosing a Canon

E

First, we'd like to thank you for purchasing this Canon camcorder. Its advanced technology makes it very easy to use — you will soon be making high-quality videos which will give you pleasure for years to come.

To get the most out of your new camcorder, We recommend that you read this manual thoroughly — there are many sophisticated features which will add to your recording enjoyment.

Getting started





To get started we suggest that you master the basic operations of the camcorder first, before moving on to use its full range of features.

For quick reference (in addition to the contents and index) please refer to:

- Finding your way around the camcorder (p. 70)
- Screen displays (p. 73)
- Troubleshooting — in case you run into any problems (p. 62)

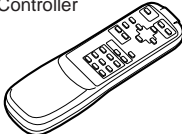
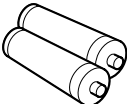
Note that capital letters are used to refer to settings displayed in the menus and buttons labelled on the camcorder itself e.g. Press the EJECT button.

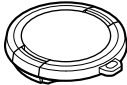
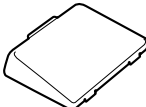
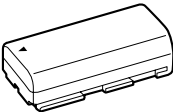
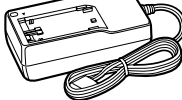
Your camcorder is supplied with the following accessories:-

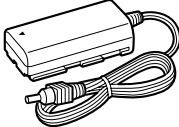
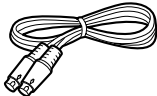
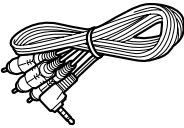
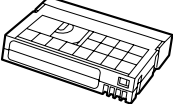
WL-D66 Wireless Controller 	Two AA batteries 
SS-200 Shoulder Strap 	Lens cap 
LCD Cover 	BP-914 Battery Pack 
CA-900 Compact Power Adapter 	Lithium button battery 
DC-900 DC Coupler 	S-150 S-video Cable 
STV-250 Stereo Video Cable 	DVM-E30 Digital Video Cassette 

Introducing the OPTURA

Digital Video

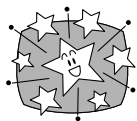

OPTURA is a next generation digital video camcorder that conforms to the new digital video **MiniDV** standard to give you outstanding picture quality.

Progressive Scan CCD

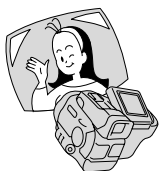

Shoot both superb quality video and beautifully clear still pictures. Choose your favorite scenes from videos (taken using progressive scan) and display them as blur-free still pictures too!

2" LCD Screen



An LCD screen makes it easy for you to shoot colorful, well composed video. It is also great for playback.

Optical Image Stabilizer



Optical technology stabilizes your recordings even at the furthest reaches of the zoom range.

14× lens and 35× digital zoom



From wide-angle to 14× telephoto — with unparalleled optical quality. The digital zoom more than doubles this magnification for even more dramatic results.

FlexiZone Control



Easier than manual operation and more flexible than automatic functions, Canon's FlexiZone Control is a completely new way to use a video camera.

Digital faders



Advanced digital technology allows you to add special effects and varied scene transitions to your recordings.

PCM Digital Sound



Offers you stunning digital sound — 16bit for greater than CD-quality sound, and 12bit for the playback of audio-dubbed cassettes.

Lithium ion power supply

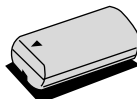

The OPTURA features the latest in portable power technology.

Powering Your Camcorder

Before operating your camera, you will need to use the power adapter to:

provide power from an AC outlet

or

charge a battery pack

Notes:

- The power adapter converts current from a household power socket (100–240 V AC, 50/60 Hz) to the DC current used by your camera.
- If the adapter is used next to a TV, it may cause the TV to emit noise — move the adapter away from the TV or the antenna cable.

Connecting the camera to an AC outlet

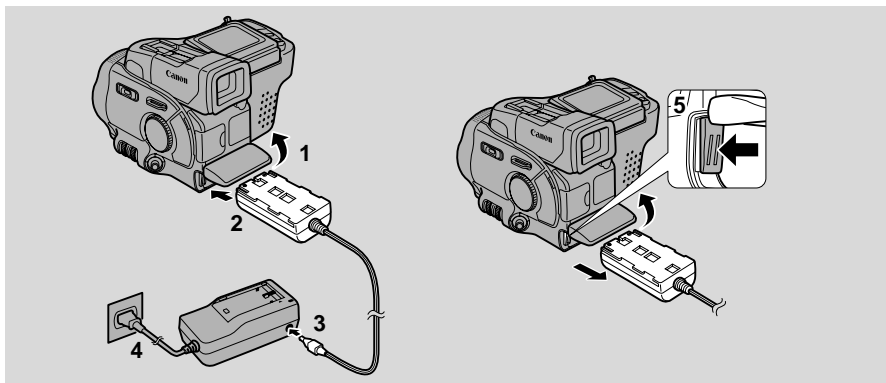

Use the power adapter and the DC coupler to provide your camera with instant power from an AC outlet.

- 1. Lift up the battery cover.**
- 2. Insert the DC coupler into the camera, with the arrow face down.**
- 3. Connect the DC coupler to the adapter.**
- 4. Plug the adapter into an AC outlet.**
- 5. Remove the DC coupler after use.**
 - Press and hold the BATTERY RELEASE knob to the left.
 - Always turn the camera off before removing the power source.

Charging and attaching the battery pack

E

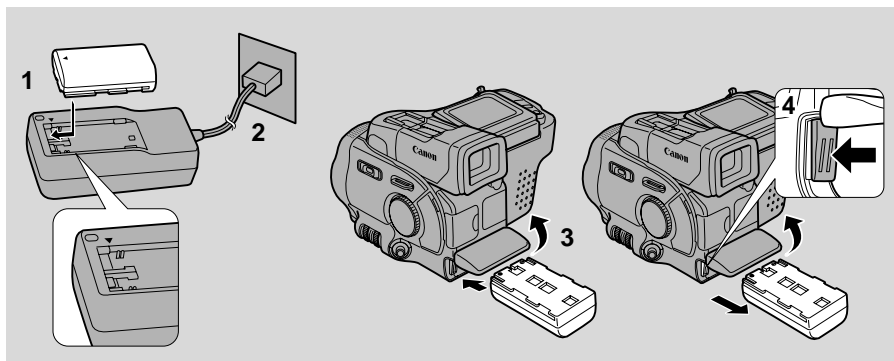

Your battery pack was partially charged before it left the factory. It should have enough power for you to check that your camera is working properly. However, you must charge the battery pack fully if you want it to power the camera for more than a few minutes.

1. Attach the battery pack to the power adapter.

- Align the triangle on the battery pack with the line on the power adapter.
- Make sure the DC coupler is not connected.

2. Plug the adapter into an AC outlet.

- The charge indicator flashes red to show that charging is in progress. Single flashes mean that the battery pack is less than 50% charged. Double flashes mean that it is between 50% and 75% charged. Triple flashes mean that it is more than 75% charged.
- The indicator glows steadily when the battery pack is fully charged.

3. Take the battery pack off the adapter and insert it into the camera.

- First lift up the battery cover then insert the battery in the direction of the arrow, with the arrow facing down, until it clicks into place.

4. Remove the battery pack after use.

- Press the BATTERY RELEASE knob to the left.
- Always turn the camera off before removing the power source.

Note:

- You can find detailed notes for using the batteries in the “Notes on Using the Batteries” on p. 55. These notes include charging and recording times and how to install the back-up battery.

Loading a Cassette

E

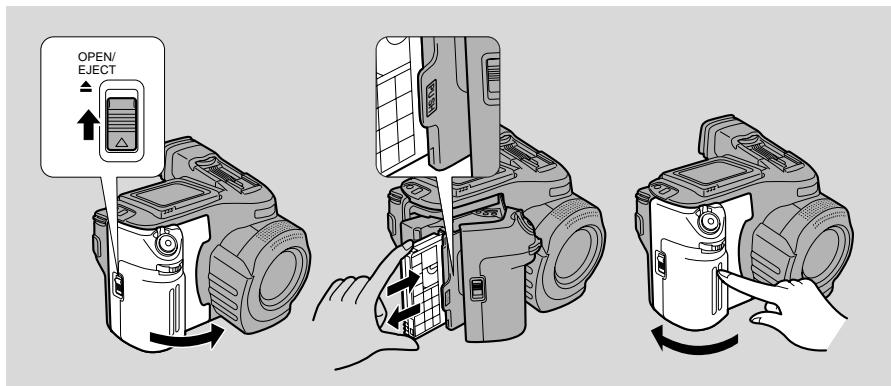

Use videocassettes marked with the **MiniDV** logo only.*

Loading and unloading

1. Make sure that you have inserted a power source.
2. Slide the **EJECT** ▲ button upwards to release the cover (the camera's grip).
 - Pull the cover fully open (while holding the button upwards) and wait a couple of seconds for the cassette compartment to open automatically.
3. Load or unload the cassette.
 - Insert the cassette gently with the window facing out.
 - Remove the cassette by pulling it straight out.
4. Press the **(PUSH)** mark on the compartment until it clicks, and wait for it to close.
5. Click the cover back into place.

* **MiniDV** is a trade mark.

Notes:

- After loading a cassette, use record search (p. 34) to find the point where you want to start recording.
- Do not interfere with the cassette compartment while it is opening or closing automatically, or attempt to close the cover.
- Do not leave the cassette in the camera after use — return it to its case and store it in a cool, clean, dry place.
- The holes in the back of the cassette are used for transferring information — do not cover them.

Protecting tapes from accidental erasure

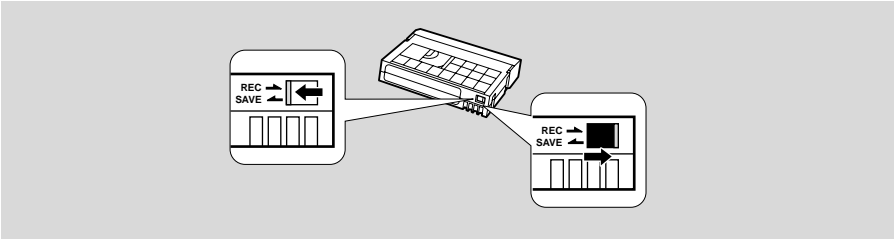

To protect your recording from accidental erasure, slide the tab on the cassette so that it exposes the hole and the red mark. (This switch position is usually labeled SAVE or ERASE OFF).

If you load this cassette and put the camera in record pause mode (p. 12), “THE TAPE IS SET FOR ERASURE PREVENTION” is displayed for approx. 4 seconds and then the  mark flashes in the display. The camera also shows the above phrase if you accidentally press the ● (record) button with the camera switched to VCR mode.

If you want to record on the cassette again, slide the tab back so the hole is closed, and the red mark covered.

Cassette Memory

You are unable to use the cassette memory function with this camcorder.

Basic Recording

E

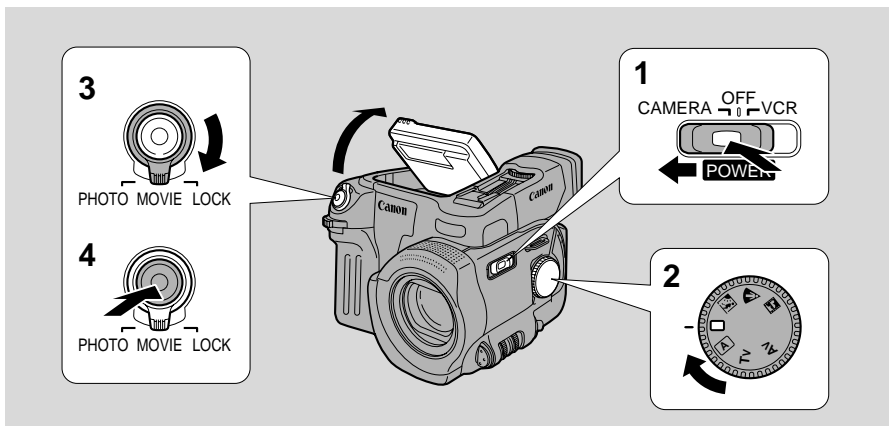

Before you start recording

Have you completed the following steps?

- Attached a power source (p. 8).
- Loaded a cassette (p. 10).
- Removed the lens cap and fastened the shoulder strap (p. 54).
- Chosen the display: viewfinder or LCD screen (p. 15)
- Adjusted the viewfinder/removed the LCD cover (as applicable, p. 54).

You may also want to install the backup battery (p. 56) in order to set the date and time display (p. 29).

To record

- 1. Press down and slide the POWER switch to CAMERA.**
 - The camera power indicator lights up red.
- 2. Turn the program selector to .**
 - This selects the camera's Easy Recording program. It allows you to simply point and shoot without making any manual adjustments (see p. 35).
- 3. Turn the standby lever to MOVIE.**
 - PAUSE appears in the display — the camera is now in “record pause mode.”
 - The camera will turn itself off if you leave it in record pause mode for more than about five minutes. To return to record pause mode, turn the standby lever to LOCK and back again, or set the POWER switch to OFF and then back to CAMERA.
- 4. Press the start/stop button to begin recording.**
 - The tally lamp flashes rapidly and REC appears in the display.

5. Press the start/stop button again to pause recording.

- The camera returns to record pause mode and PAUSE reappears in the display.
- You can stop and restart recording as often as you like by pressing the start/stop button.

6. Turn the standby lever to LOCK.

- As long as the POWER switch is set to CAMERA, you can use the standby lever to turn the camera on and off. This makes it easy to save battery power, and prevents accidental operation of the start/stop button.

When you have finished recording

- Replace the lens cap.
- Return the LCD screen flush to the camera body, and replace the LCD cover.
- Unload the cassette.
- Set the POWER switch to OFF.
- Disconnect the power source.

Notes:

- To check that the camera is recording correctly, make a test recording first.
- Before making important recordings, clean the video heads using a Canon DVM-CL Digital Video Head Cleaning Cassette or a commercially available digital video head cleaning cassette.
- You cannot monitor the sound from the speaker when recording.
- For tips on how to make better videos, see page 22.

Changing the recording mode (SP/LP)

You can record and play back a tape in SP (standard play) and LP (long play) modes. LP extends tape usage by 1.5 times.

To switch to LP mode, select REC MODE from the camera or VCR menu, select LP and then close the menu (for instructions on how to use the menus, refer to page 25).

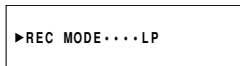

Notes:

- If you record in both modes on the same tape, the picture may become distorted during playback and the time code may not be written correctly.
- A tape recorded in LP mode on another camcorder may produce mosaic-like noise when played back on this camcorder, and vice versa.

Zooming

E

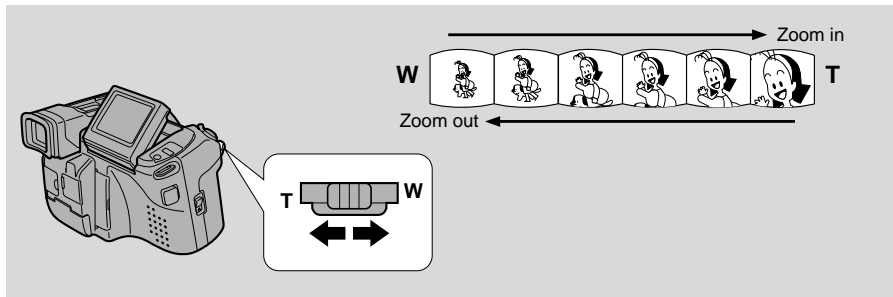

14× optical zoom

The camera's 14× zoom lens allows you to choose the best picture angle for each scene:

- Turn the zoom control towards W to zoom out to wide-angle.
- Turn it towards T to zoom in to telephoto.

You can also control the speed of zooming:

- Move the control slightly to zoom slowly.
- Turn it further to zoom more quickly. (The further you turn the zoom control, the faster the zoom speed.)

The T and W buttons on the wireless controller adjust the picture angle, but not the zoom speed.

35× digital zoom

Turn the digital zoom on from choosing D. ZOOM ON at the camera menu, to more than double the camera's zoom range.

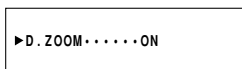

(For an explanation of how to use the camera menu see page 25)

The zoom control continues to work as usual. You can freely zoom in and out between 1× and 35× magnification — the camera automatically switches between optical zooming (up to 14×) and digital zooming (14× to 35×).

Notes:

- When you want to get as close as possible to your subject, keep the zoom at the wide-angle position. You can focus on a subject as close as 3/8 in (1 cm).
- Image resolution is slightly lower when the magnification is greater than 14×.
- You cannot use the digital zoom with the Negative-Positive Conversion program or with the mosaic fade and window wipe.

Using the LCD Screen

Switching between displays

You can choose between using the LCD screen and the viewfinder by pressing the MONITOR/FINDER button.

Changing the angle of the LCD screen

You can choose the angle of the screen that suits you best by tilting it towards you.

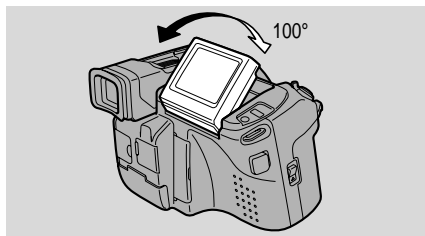

Notes:

- Avoid touching the LCD screen.
- Do not hold the camcorder by the LCD panel.
- Bright light falling on the LCD screen may cause glare that makes it difficult for you to view the image. In this case, switch to using the viewfinder.
- When you turn on the camera, the display always appears on the LCD screen in VCR mode.

The display may appear in the viewfinder in camera mode, if you were using the viewfinder when the camera was turned off.

About the LCD Viewfinder/Screen

Liquid Crystal Viewfinders use extremely high-precision technology, but there will be pixels which do not light up or which are continuously lit. This is not an error and will not affect the recording.

Built-in speaker

The camcorder has a built-in speaker so you can review the sound track alongside the picture during playback.

Adjust the speaker volume by choosing VOLUME at the VCR menu, and setting the volume to HIGH, MEDIUM or LOW. Turn the speaker off completely by selecting OFF.



►VOLUME.....MEDIUM

(For an explanation of how to use the camera menu see page 25)

Note:

- The speaker turns off when the camera is set to camera mode and when you use headphones.
- You cannot adjust the volume of attached headphones.

Playing back a Cassette

E

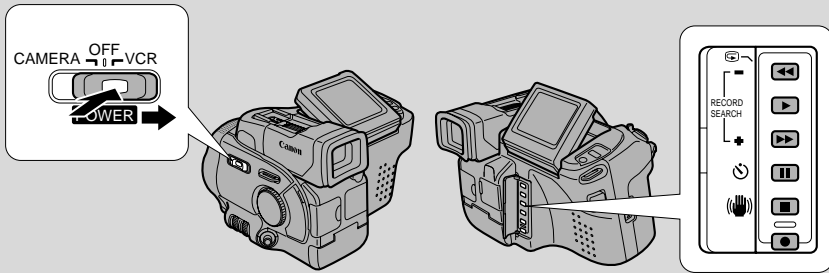

You can use the LCD screen for instant, on-the-spot playback. The camera also plays back the sound track via the built-in speaker (p. 15).

To play back your recordings on a TV, see p. 19.

To use the wireless controller, see p. 27.

Note:

- To avoid accidental recording, make sure that you slide the tab on the cassette so that it exposes the hole (the switch position is usually labelled SAVE or ERASE OFF).

- 1. Attach a power source and slide the POWER switch to VCR.**
 - The power indicator lights up green.
- 2. Load the cassette.**
- 3. Press the PLAY ► button to start playback.**
 - To end playback, press the STOP ■ button.
 - To wind the tape forwards, stop playback and press the FF ►► button.
 - To wind the tape backwards, stop playback and press the REW ◀◀ button.
 - If the playback picture is rough (mosaic-like noise), clean the video heads using a Canon DVM-CL Digital Video Head Cleaning Cassette or a commercially available digital video head cleaning cassette.

Other playback modes

Playback pause

Press the PAUSE **||** button. To resume normal playback, press it again, or press the PLAY **▶** button. The camera automatically goes into stop mode after about five minutes' playback pause.

Fast forward playback

To play back the recording at about 9.5 times normal speed, press and hold the FF **▶▶** button during normal playback or press and hold the FF **▶▶** button during normal fast forward.

Rewind playback

For reverse playback at about 9.5 times normal speed, press and hold the REW **◀◀** button during normal playback or press and hold the REW **◀◀** button during normal rewind.

Special playback

These can only be operated from the wireless controller (p. 27)

Frame Advance

To play back frame by frame, press the +/▶▶ button repeatedly during playback pause.

Press and hold to play back continuous frame advance.

Frame Reverse

To play back on reverse frame by frame, press the -/◀◀ button repeatedly during playback pause.

Press and hold to play back continuous frame reverse.

Slow Forward Playback

To play back at about 1/5 normal speed, press the SLOW ▶▶ button during normal playback.

Press the PLAY ▶▶ button to return to normal playback.

- The camera automatically returns to playback after about 30 seconds of slow playback.

Slow Reverse Playback

To play back in reverse at about 1/5 normal speed, press the -/◀◀ button and then the SLOW ▶▶ button during normal playback.

Press PLAY ▶▶ to return to normal playback.

- The camera automatically returns to ×1 reverse playback after about 30 seconds of slow playback.

Reverse Playback

To play back in reverse at normal speed, press the -/◀◀ button during normal forward playback.

Press the PLAY ▶▶ button to return to normal forward playback.

Forward ×2 Playback

Press the ×2 button during normal playback.

Press the PLAY ▶▶ button to return to normal playback.

Reverse ×2 Playback

Press the -/◀◀ button and then the ×2 button during normal playback.

Press the PLAY ▶▶ button to return to normal playback.

Note:

- Mosaic-like noise appears on the screen during some of the VCR modes and the sound track cannot be heard.

Connections for Playback on a TV Screen

You can connect the camera to a TV or VCR in order to play back your recordings. You will need to attach a power source to the camera (see p. 8).

See your TV or VCR instruction manual for further details.

E

If your TV (or VCR) has an S-video input terminal

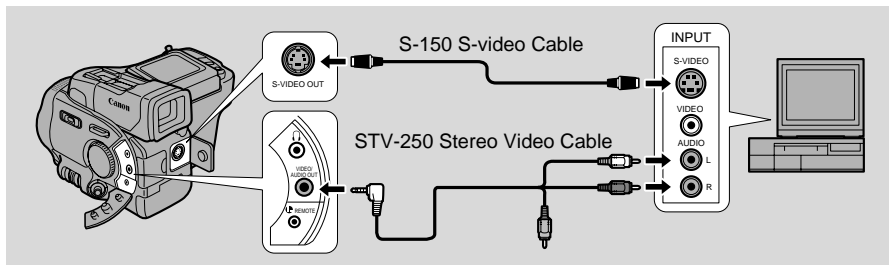

- Use the S-150 S-video Cable to connect the S-video terminal (S). Use the STV-250 Stereo Video Cable, to connect the AUDIO terminals. Connect the white plug to the white AUDIO terminal (L) (left). Connect the red plug to the red AUDIO terminal (R) (right). Do not connect the yellow plug.
- Set the TV/VIDEO selector on the television to VIDEO.
- If you are connecting the camera to a VCR, set the input selector on the VCR to LINE.

If your TV (or VCR) has audio/video input terminals

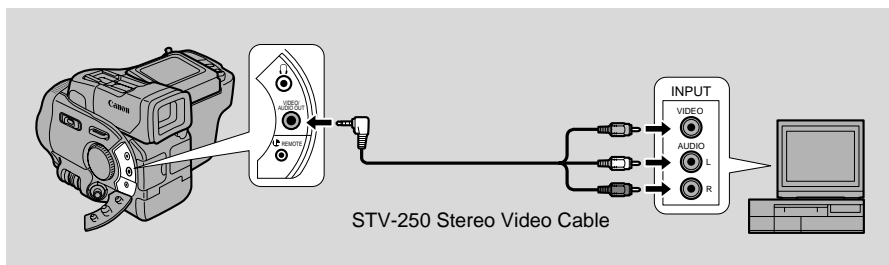

- Connect the camera using the STV-250 Stereo Video Cable. Connect the white plug to the white audio terminal (L) (left). Connect the red plug to the red audio terminal (R) (right). Connect the yellow plug to the yellow video terminal (V).
- Set the TV/VIDEO selector on the television to VIDEO.
- If you are connecting the camera to a VCR, set the input selector on the VCR to LINE.

Note:

- If you are going to use the TV as a monitor while you are shooting, remember to keep the TV volume turned down as long as the camera's audio terminals are connected. If the sound from the TV speakers is picked up by the microphone, an unpleasant high-pitched squeal, called feedback, may be produced.

If your TV is already hooked up to a VCR, you can connect the camera to the VCR instead of the TV. Follow the instructions on the previous page.

If your TV does not have audio/video terminals

TV with coaxial antenna cable

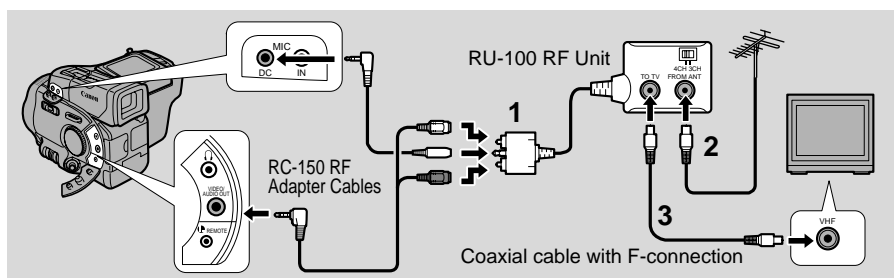

TV with flat twin-lead antenna cable

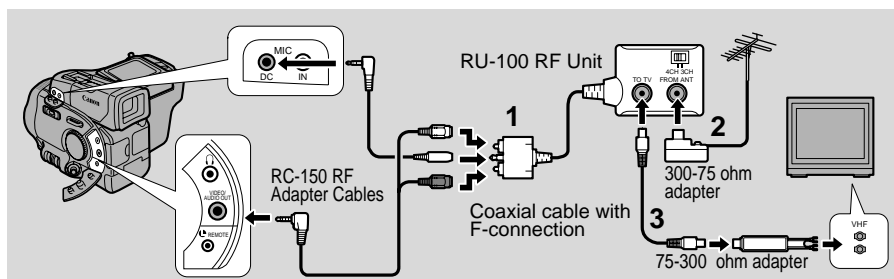

To connect the camera directly to a TV which does not have audio/video terminals, you will need to use the optional RU-100 RF Unit together with the optional RC-150 RF cables.

Connecting the RF unit/adapter cables

1. **Connect the RF unit to the camera, using the RC-150 RF adapter cables.**
 - The RF unit and RF adapter cables are available optionally.
2. **Connect the antenna cable to the FROM ANT. terminal on the RF unit.**
 - If your TV has flat twin-lead cable, use the 300–75 ohm adapter.
3. **Connect the TO TV terminal on the RF unit to the antenna input on the TV.**
 - Use the coaxial cable with F-connectors.

If your TV has flat twin-lead cable, use the 75–300 ohm adapter.

Attaching the 300–75 ohm adapter

Loosen the screws on the adapter and insert the antenna cable. Tighten the screws again.

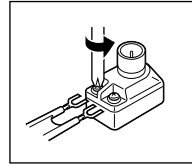

If the antenna cable does not have antenna lugs, you will need to strip one end of the cable and wind the wires around the screws.

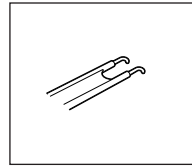

Selecting the video channel

Turn the TV on, start playback on the camera (see p. 16), and set the TV and the RF unit to the video channel.

The video channel is the channel which is not used by a broadcasting station in your area and can be used for cassette playback (channel 3 or 4).

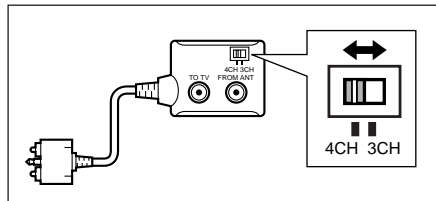

Note:

- Turn the camera off or disconnect it from the RF unit when you want to watch a broadcast program.

Tips for Making Better Videos

E

Holding the camera

For maximum stability, grip the camera firmly with your right hand and keep your right elbow pressed against your body. Support the camera under the lens with your left hand. With practice, you will be able to operate the controls by touch, without taking your eye off the action.



Using a tripod

To prevent any unwanted movement, you can mount the camera on a tripod, (or any flat surface at a suitable height.) and operate it with the wireless controller.

- When you are using a tripod, be careful not to leave the viewfinder exposed to bright sunlight or it may melt. (The light is concentrated by the viewfinder lens.)
- Make sure that the fastening screw of the tripod is no longer than 3/16 inch (5.5 mm), or it will damage the camera.



Composition

The most important element in the scene does not have to be in the center. For a more interesting picture, try to position your subject so it is slightly to one side. Leave some space on the side of the frame that the subject is facing or moving towards.



Don't cut off the top of the subject's head, and don't cut people off at the neck, hips or knees (move a little bit above or below).

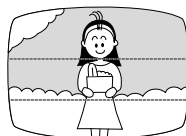

Watch out for distracting objects in the background.



Picture angle

Instead of zooming while recording, try to choose your picture angle before you begin. A good way to tell a story with video is to begin with a long shot that establishes the situation, and then move in with medium shots and close-ups to show the details. Remember to change your viewpoint for each shot.

Remember that any camera movement or change in picture angle should have a definite purpose. Avoid unnecessary or half-hearted movements.



Long shot



Medium shot



Close-up

Camera moves

Use pans to record a landscape or follow a moving subject. Decide the area you want to cover and stand facing the end of your panning angle. Without moving your feet, turn your waist to the starting position. Start recording, and after a few seconds begin to turn slowly from the waist. Hold the final image for a few seconds before you stop recording.

Tilt the camera up to exaggerate the height of the subject. Tilt down from the top of a building, for example, as an introduction to subjects at the bottom.

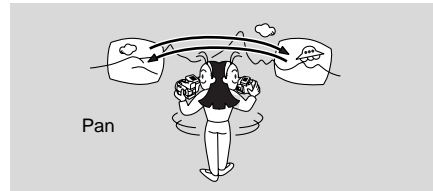

Pan



Tilt

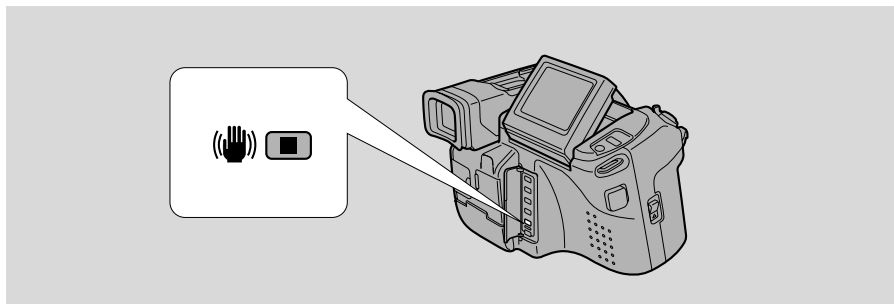

Turning the Optical Image Stabilizer On/Off

E



With most camcorders, even the slightest hand movements will be noticeable during telephoto recording. However, the OPTURA's Optical Image Stabilizer allows you to obtain steady recordings even at 14× or 35× magnification. Unlike electronic image stabilizers, it causes no loss of picture quality. The Optical Image Stabilizer can compensate for a wide range of camera movement — you can record stable images even if you are shooting from a moving car.

Before you start recording, open the rear button cover and push the  on/off button to turn the image stabilizer on or off.

- The  mark appears in the display when the stabilizer is on.
- The image stabilizer cannot be turned off when the program selector is set to the  (Easy Recording) position.

Notes:

- The image stabilizer is designed to deal with a normal degree of camera shake.
- Keep the image stabilizer turned off when the camera is mounted on a tripod.
- The image stabilizer is not as effective as usual when the tele-converter (optional) is attached.

Selecting from the Menu

Many of the camera's advanced functions are selected from menus which appear in the display.

There are two main menus:

1. **Camera menu (when the camera is in record pause mode: the POWER switch set to CAMERA and the standby lever set to MOVIE or PHOTO)**
2. **VCR menu (when the POWER switch is set to VCR)**

Camera menu (CAM. MENU)

- ① Digital zoomp. 14
- ② Wind screen.....p. 43
- ③ White balancep. 49
- ④ 16:9 effectp. 42
- ⑤ Movie modep. 33
- ⑥ Remote sensorp. 28
- ⑦ Tally lamp.....p. 28
- ⑧ Audio mode.....p. 43
- ⑨ Record modep. 13
- ⑩ Date/time setp. 29

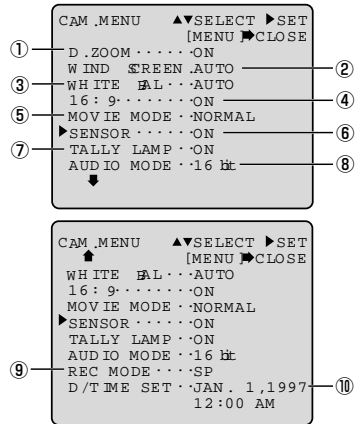

VCR menu

- ① Tally lampp. 28
- ② Remote sensorp. 28
- ③ Record Modep. 13
- ④ Mix balance.....p. 58
- ⑤ Volumep. 15
- ⑥ Data code.....p. 30
- ⑦ Date/time select.....p. 29
- ⑧ Date/time setp. 29

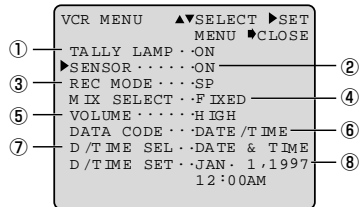

Turn to the appropriate page for a detailed explanation of each function.

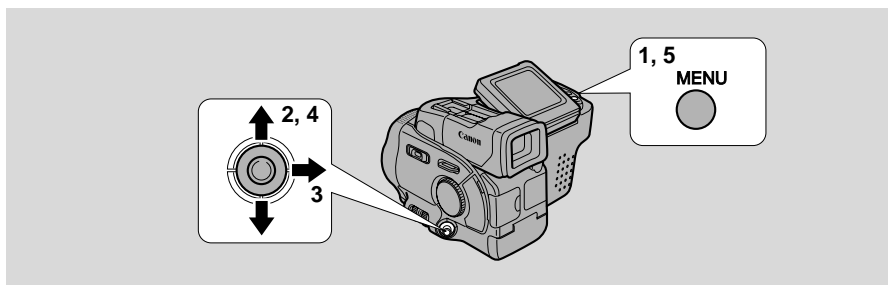

1. Press the MENU button to open the menu.
2. Press the controller up or down to move the arrow up or down the display.
3. Press the controller to the right (towards you) to select your chosen option from the menu.
 - Your selected option remains on the screen and all other options are removed.
4. Press the controller up or down to choose its setting.
 - You can return to the full menu by pressing the controller to the left (away from you).
5. Press the MENU button to close the menu.

Notes:

- You can only see eight options on the screen at the same time. Pointers at the top/bottom of the screen indicate that there are more options that you can scroll through.
- You may often find it convenient to use the wireless controller to move around the menus. Press its MENU button to enter/leave the menu and use the cursor keys in place of the FlexiZone controller.
- You can display the menus on a connected TV screen using the wireless controller's TV SCREEN button.

Using the Wireless Controller/Tally Lamp

E

The supplied wireless controller can operate the camera from a distance of up to 16 feet (5 m). Point it at the camera's remote sensor while you press the buttons.

The tally lamp lights up to let you know that the camera is in range and responding to your commands.

There are five functions which can only be operated using the wireless controller:

- Special playback (p. 18)
- TV-screen displays (p. 73)
- Data code on/off (p. 30)
- Photo search (p. 32)
- 12 bit Audio output (p. 58)

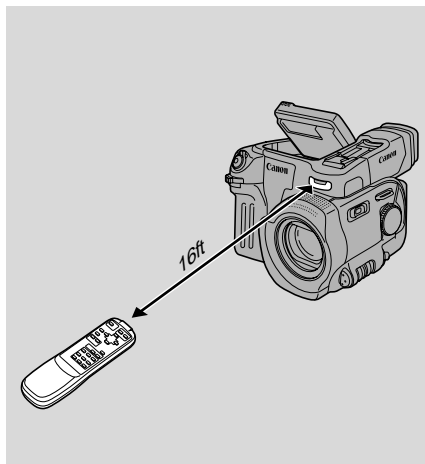

Inserting batteries

Insert two AA batteries, following the \oplus and \ominus markings. Be careful not to reverse the polarity of the batteries.

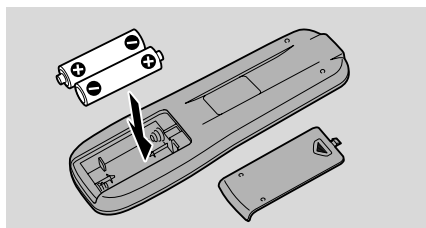

Notes:

- When using the wireless controller in brightly lit places or outdoors, the effective range will be less.
- The camera may have difficulty picking up the remote control signals at extremely close range.
- Do not leave the controller exposed to direct sunlight, or in hot or humid places.
- When the batteries run out, replace them both together.

Turning off the remote sensor

The remote sensor can be turned off to prevent interference from other Canon wireless controllers being used nearby.



▶SENSOR.....OFF

1. Open either the camera or the VCR menu, and point the arrow at **SENSOR**.
2. Select the **OFF** setting and close the menu.
 - S **OFF** appears in the display.

Turning off the tally lamp

The tally lamp lets you know that the camera is recording. However, its flashing may be reflected into the lens during close-up recording, or when recording through glass.

You may therefore decide to turn it off.

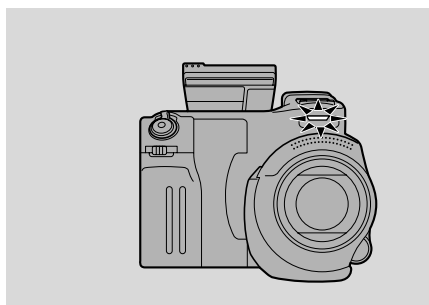

▶TALLY LAMP..OFF

1. Open either the camera menu or the VCR menu, and point the arrow at **TALLY LAMP**.
2. Select the **OFF** setting and close the menu.
 - The tally lamp no longer flashes during recording, but it will still light up when the camera receives a signal from the wireless controller.

Setting the Date and Time

E

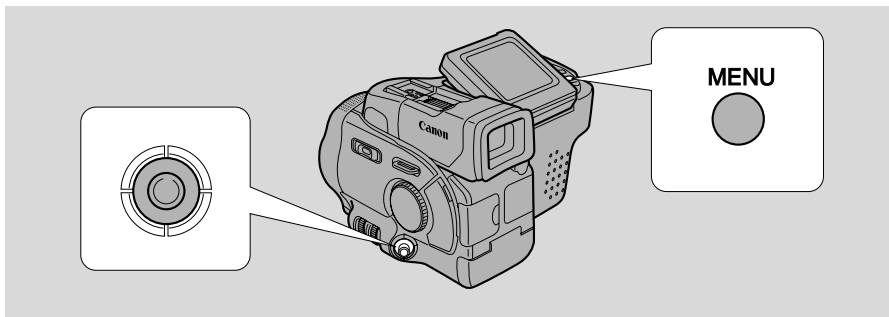

The date and/or time display forms part of the data code. You can choose to display or hide it during playback (see p. 30).

Set the date and time display when you first start using your camera. Install the backup battery before you begin (see p. 56).

1. Put the camera in record pause or VCR mode.
2. Open the menu and select D/TIME SET.
 - The year display starts to flash.
3. Press the controller up and down to change the year. Press sideways to move to another part of the display.
 - Press once to scan a year at a time. Press and hold to scan quickly.
 - Once you move from the year, the next part of the display starts flashing.
4. Set the months, days, hours, and minutes in the same way.
5. Press the MENU button when finished, and to start the clock.

- The date can be set to any year between 1997 and 2020.
- If you press the MENU button in the middle of setting the date and time the seconds are set to zero, you leave the menu, and the clock starts.
- If you press the controller to the right after setting the minutes you can set the date and time again from the start.

Setting the display style

MENU
(see p. 25)

▶D/TIME SEL.·DATE & TIME

1. Press down and slide the POWER switch to VCR.
2. Open the VCR menu and select D/TIME SEL.
3. Choose between DATE, TIME and DATE & TIME.
4. Press the MENU button to close the menu.

Displaying Data Code

E

A data code, containing the date and time the recording was made and other camera data (shutter speed and exposure settings) is automatically recorded on a special data section of the tape.

During playback, the date code can be displayed or hidden while the camera is in stop, fast forward, rewind, play or still mode.

Press the wireless controller's DATA CODE button.

- Press it once to display, once more to hide it.

You can also choose which type of data code to display — either the date/time, camera data or both.



1. **Select DATA CODE from the VCR menu.**
2. **Choose between DATE/TIME, CAMERA DATA and CAM. & D/T.**
3. **Press the MENU button once more to close the menu.**

Notes:

- To avoid accidental recording, make sure that you slide the tab on the cassette so that it exposes the hole (the switch position is usually labelled SAVE or ERASE OFF).
- The data code will read “— — —” in the following situations:
 - During playback of a blank section of tape.
 - If the tape was recorded before entering the date and time in the camera's memory.
 - If the tape was recorded on a camera without a data code function.
 - If noise or tape damage prevents the data code from being read.
- Data code is not displayed during high speed playback modes.
- If a recording made on OPTURA is played back on a different DV camcorder, the data code may not be displayed correctly.

Taking Still Pictures (Photo Mode)

E

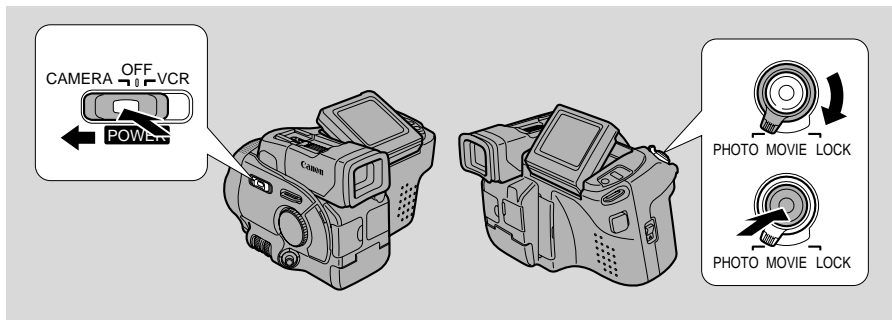

You can record still pictures like a photograph. The camera records the picture to tape for approximately 6 seconds. The exposure is automatically adjusted.

1. Set the camera to photo standby mode (slide the **POWER** switch to **CAMERA** and turn the standby lever to **PHOTO**).

- “PHOTO” is shown at the bottom right of the display.

2. Press the start/stop button lightly.

- **●** flashes white in the display as the camcorder adjusts the focus and exposure and it is displayed continuously as a green mark when the camera is ready to take the still picture. (The focus, exposure, and zoom are now locked. Also, you cannot turn the image stabilizer on/off)
- To change the still picture before recording: release the button, select a new picture and then press down the start/stop button lightly once more.
- If the subject is unsuitable for autofocus (p. 63), the camera may not be in focus, despite displaying the green mark. In this case: release the start/stop button, adjust the focus manually (p. 47) and retry.

3. Press the start/stop button fully down to take the still picture.

- The camera takes the image almost immediately, and then records the “photo” to the tape for approximately 6 seconds. During this time the camera also records the sound, and the display also shows the still picture.
- A counter display is shown, that counts up to 6 secs as the camcorder records the picture. **●** disappears from the display.

Notes:

- While the camera records the still, you cannot use the camera functions (program selector/power off do not respond until recording is complete).
- You cannot use digital faders while the camera is set to photo mode.
- You cannot use FlexiZone AF in photo mode.
- The camera operates in progressive mode when taking still pictures.
- For even greater versatility attach a Canon Speedlite for flash photography (available as an optional accessory, see page 45).
- Only take “photos” where it is bright enough to see the image in the display.

Searching Through Your Recorded “Photos” (Photo Search)

E

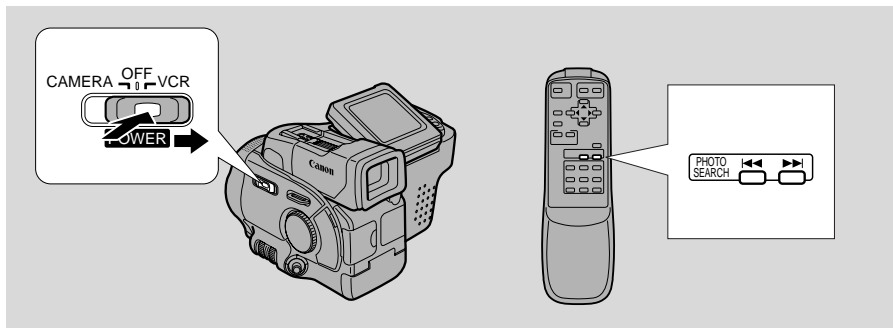

Move quickly through still pictures recorded anywhere on a tape.

- You can only use this function from the Remote Controller.

- 1. Press down and slide the POWER switch to VCR.**
- 2. Press the ◀◀ and ▶▶ buttons to move backwards or forwards through the still pictures.**
 - Press once to move to the start of the previous/next still pictures on the tape.
 - Press more than once to move to the corresponding still picture (up to a maximum of 10 times), e.g. press the ▶▶ button 5 times to move forward 5 still pictures on the tape.
 - PHOTO SEARCH appears in the middle of the display alongside the ◀◀ or ▶▶ mark and the number of photos to search through.

Notes:

- Press the ■ button to end your photo search.
- Pressing the ◀◀/▶▶ buttons again (while the camera is searching) has no effect.
- If you begin a search very close to the start of a recorded still picture, the camera may skip straight past it.

Choosing the Movie Mode (Normal/Progressive Scan)

E

The progressive scan mode can be used when you want to look at a video, scene by scene, free from field slippage (the “blurring” that normally occurs when you pause a video). During playback, pause the video any time you like to view a crystal clear still image in the display or on a connected TV screen. It is also possible to transfer your favorite still pictures to a PC for image enhancement and print out.



1. Slide the **POWER** switch to **CAMERA**.
2. Turn the standby lever to **MOVIE** and the program selector to any recording program except Easy Recording.
3. Open the camera menu, and point the arrow at **MOVIE MODE**.
4. Choose the **PRO.SCAN** setting and close the menu.
 - PRO.SCAN appears in the display.

Notes:

- To return to normal video shooting, you need to re-select **NORMAL** from **MOVIE MODE** at the camera menu.
- Progressive scan mode cannot be used with the Easy Recording program or the mosaic fade and window wipe.
- Normal mode cannot be used with the Negative-Positive Conversion program.
- Progressive scan video may appear slightly jerky during normal playback.

Searching and Reviewing While Recording

E

Record search

When the camera is in record pause mode, you can use record search to play the tape forwards or backwards to find the point where you want to start or restart recording. This is useful when you want to add a new scene to a previously used cassette. By using record search, you can ensure a smooth, noise-free join between the new scene and the old one.

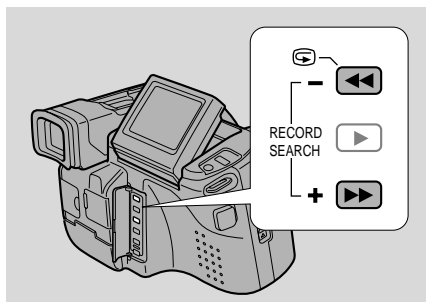

1. **Make sure the camera is in record pause mode.**
2. **Press and hold the RECORD SEARCH + or – button while you check the picture in the display.**
 - The + button plays the recording forwards and the – button plays it backwards.
3. **Release the button when you find the point where you want to start recording.**
 - The camera returns to record pause mode.

Record review

When the camera is in record pause mode, you can use record review to play back the last few seconds of your recording and then return automatically to record pause mode. You can quickly make sure that a scene has recorded properly and then go on to shoot the next scene, without producing any noise in the picture.

1. **Make sure the camera is in record pause mode.**
2. **Press and release the  (record review) button while you check the picture in the display.**
 - The camera rewinds the tape, plays back the last few seconds, and returns to record pause mode.

Note:

- Noise may appear on the screen during record search and record review.

Using the Various Recording Programs

E

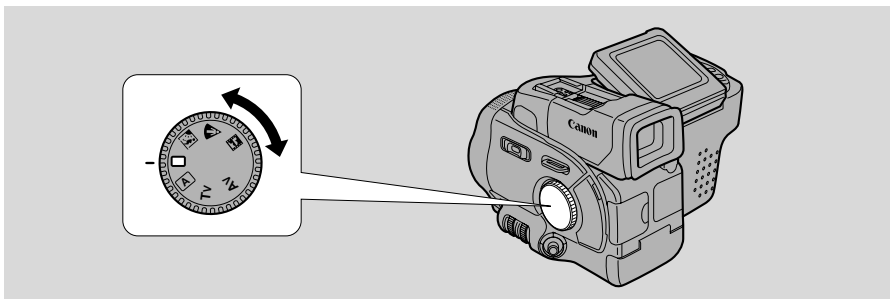

The camera provides you with a choice of seven recording programs. They use different combinations of camera settings in order to adjust the exposure and other functions to match the recording situation.

- For simple point-and-shoot operation, select the Easy Recording program. Turn the program selector to the position.
- For normal shooting conditions, set the selector to A (Auto).
- For various other recording conditions, the camera has five more specialized AE (auto exposure) programs.

The name of your selected recording program appears constantly on the left of the display, with the exception of the Easy Recording program whose mark is displayed and then disappears after 4 seconds.

Notes:

- Avoid changing programs during recording as the brightness of the image may change suddenly.
- The specialized AE programs are not suitable for all kinds of lighting. The image may flicker, or a bright line may appear on the screen if you use them in the wrong lighting conditions.

Easy Recording

The simplest way to use the camera is with the program selector set to the position. The camera will take care of focus, exposure and other adjustments, leaving you free to point and shoot.



If you select this Easy Recording program, you cannot use:

- Progressive scan movie mode
- Exposure lock or compensation
- White balance set
- 16:9 effect
- Digital faders

Also, autofocus and image stabilization cannot be turned off.

Auto

In normal recording conditions, set the program selector to  (Auto). This is the same as the Easy Recording program, except that you now have the option of using any of the camera's manual functions — you can adjust focus and exposure, set the white balance, and so on.



AUTO



Sand & Snow

Use this program in places where the background is so bright that the subject appears underexposed in the display — a sunny beach or ski resort, for example. You may notice some shudder when recording moving subjects.



SAND&SNOW



Spotlight

This program is designed for recording spotlit scenes, such as on a stage. The exposure is automatically adjusted for glare-free recordings of subjects lit by a concentrated light source.



SPOTLIGHT



Giving priority to shutter speed (shutter-priority: Tv)

Use this program to let you select the shutter speed.

The camera sets the appropriate aperture (F number) automatically to give the correct exposure.

Tv



High shutter speeds are perfect for recording fast moving subjects (such as sports action) when you want to play back videos frame by frame, free from blur caused by the movement. But remember, in normal playback, fast moving subjects may appear to “strobe” (move jerkily). You can also choose slow shutter speeds (1/30, 1/15 and 1/8 of a second) for dramatic effects, such as a “streaming” background when panning, and for shooting in low-light conditions.

When you turn the program selector to Tv the current shutter speed is show in the display. Select your desired shutter speed by turning the Av/Tv CTRL.

You can choose shutter speeds of between 8 and 2,000. For a faster shutter speed, select a higher value.

Notes:

- The image quality may suffer slightly if you use slow shutter speeds for low-light conditions, and the autofocus may have not give accurate results.
- When recording in extreme low-light conditions, we recommend the use of a Canon Speedlite or Video Light (available as optional accessories, see page 66).
- When shooting using the Tv program, if the shutter speed display flashes the camera has not been able to set the exposure correctly. In such a case, change the setting so that the display stops flashing and lights up continuously.

Giving priority to the aperture (aperture-priority: Av)

Use this program to let you select the aperture (iris diameter) to give you maximum control over the depth of field (the picture's zone of sharp focus). It is the reverse of shutter-priority. The camera sets the appropriate shutter speed automatically to give the correct exposure.

Wide apertures (lower F-numbers) are great for making still-lives and close-ups stand out from a softened foreground and background. The effect is most noticeable when the zoom is towards the telephoto end. Focus manually for maximum accuracy and be careful when recording action scenes, as this program may cause "strobing" of fast moving images. Choose a wider aperture to enable you to shoot in low-light conditions.

When you turn the program selector to Av the current F (aperture) number is shown in the display. Select your desired F number by turning the Av/Tv CTRL.

You can choose F numbers of between F1.8 and F32. For smaller aperture, select a higher value for the F number.

Notes :

- The Tv and Av values are reset if you turn the power off or turn the program selector to another setting. If you turn the standby lever to LOCK, the camera remembers your chosen values.
- You are able to press and hold the Av/Tv CTRL (EXP wheel) after setting the Av or Tv to lock/adjust the exposure (p. 46).
- When shooting using the Av program, if the F number display flashes the camera has not been able to set the exposure correctly. In such a case, change the setting so that the display stops flashing and lights up continuously.

Av



Negative-Positive Conversion

Records a color negative of the image. White appears as black, yellow appears as blue, green appears as red, etc. Also converts a negative image to an ordinary positive one. This can also be used with the optional accessories FP-100 Film Adapter and SL-49/46 Step-down Converter Lens to transfer 35mm film negatives to the camera.



- You can use exposure adjustment, but you should do so before adjusting any other settings such as white balance.
- You can also then adjust the tint and color.

To use the conversion program, put the camera in record pause mode and turn the program selector to **PA**.

You can also alter the strength and tint of the colors, plus mask the edges of the picture when using the Film Adapter (FP-100).

1. **Display TINT, COLOR and MASK. options by moving the controller up or down.**
2. **Adjust the level or choose the type of masking by pressing the controller up or down to choose the option and then left/right to change its setting.**

Tint:

- There are 15 possible settings. When converting a negative image, around setting 5 gives the converted image the most reddish tint, around 10 gives the most bluish tint.

Color:

- The settings for the overall strength of the colors varies from +5 to -5. Setting -5 gives a black and white image. Use this when converting black & white negatives.
- When you adjust the tint or color, **M** appears in the display.
- When you select a different recording program or switch the power off, the tint and color will return to a level set automatically by the camcorder and the **M** will disappear from the display.
- Also, when you change the film you need to return the tint and color to the automatic levels in the same way.

Masking:

- There are 6 masking settings, three portrait (vertical) maskings and 3 landscape (horizontal) maskings.
- **≡2** and **||2** correspond to the Advanced Photo System, the others to 35 mm film.
- The options disappear from the frame a few seconds after your last operation.

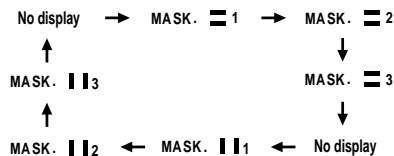

Note:

- The camera mode is set to progressive scan by the camera; you cannot select normal mode.

Fading In and Out Between Scenes

E

Use the digital fader functions to start or end a scene with a fade to or from black.

Vertical Wipe

When you start recording the picture appears from the right hand side of the screen and expands sideways until it fills the whole screen. When you end a scene, the image is wiped back off.

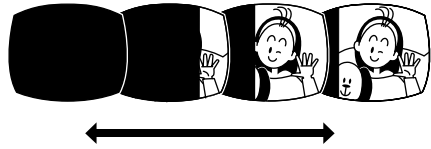

Window Wipe

When you start recording, the image begins as a square dot in the middle of the screen which gradually expands to fill the screen. When you end a scene, the image is wiped from all 4 sides simultaneously.

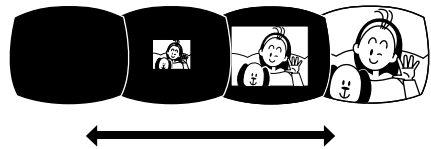

Fade Trigger

When you start recording, the scene gradually fades in from a black screen. When you stop recording, it gradually fades out.

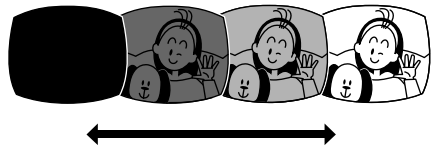

Mosaic Fade

This blurs the image by enlarging the size of some pixels. the image appears as increasingly large squares of color, as it fades out.

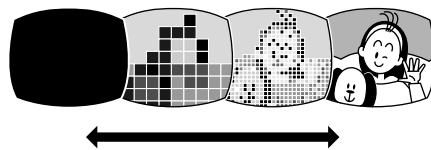

Using digital faders

E

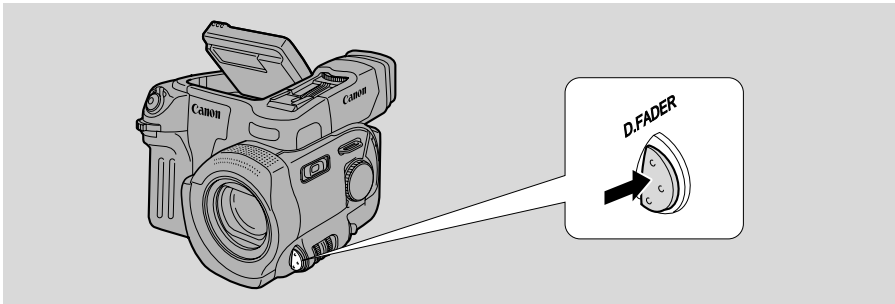

Activate the function each time you wish to use it (both before you fade in and again before you fade out) by pressing the D.FADER button. The name of the fader is shown in the display when it is activated.

1. Put the camera in record pause mode.
2. Press and hold down the D.FADER button (for about 2 seconds) to display the fader options on the screen.
3. Scroll through the list to your chosen fader by pressing the D.FADER button.
 - The flashing display changes.
 - Alternatively, keep the button pressed down to scroll through the list.

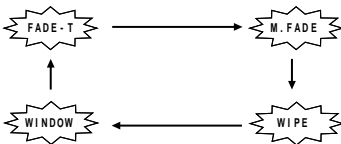

4. When you reach your chosen fader stop pressing/release the button and your chosen fader will be put into the memory.
 - The camera automatically exits the fader option screen after a few seconds.
 - The name of your chosen fader is shown in the display.
5. Start or stop recording.
 - The recording will start or stop with the selected fade.
 - Sound and image fade together.
 - The display will start flashing again. If you wish to use the fade again, press the D.FADER button again.
 - You can turn the selected fade effect off before you use it by pressing the D.FADER button again.

Notes:

- You are unable to use any of the digital faders when the camera is set as follows:
 - Easy Recording program.
 - Negative-Positive Conversion program.
 - Tv and Av.
 - Photo mode.
- You cannot use the mosaic fade or the window wipe if:
 - You have turned on the digital zoom or 16:9 effect at the menu.
 - The recording program is set to Auto, Sand and Snow or Spotlight (when the camera is set to PRO.SCAN movie mode).

When you enter the fader options screen M.FADE and WINDOW are shown in purple and cannot be selected. If you have already activated one of these faders, and then change the camera setting to one of the above, the fader name flashes purple for about four seconds and then disappears from the display (it is deactivated).

16:9 (Widescreen TV recording)

Produces images in the 16:9 format for playback on widescreen TVs.

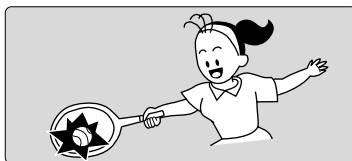

- 1. Select 16:9 from the camera menu and turn the effect ON/OFF.**
- 2. Press the MENU button once more to close the menu.**

Notes:

- “16:9” is shown in the display when you switch the 16:9 effect on.
- You cannot use the 16:9 digital effect with the Easy Recording program, the Negative-Positive Conversion program, or with the mosaic fade and window wipe.
- If you play back a recording made for 16:9 on a normal TV screen, the image will appear to be vertically “squashed” (compressed).

Audio Recording

Selecting the audio mode

E

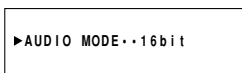

OPTURA can record sound in two audio modes — 16 bit (48kHz, 2 channel) and 12 bit (32 kHz, 4 channel). The 16 bit mode produces the higher sound quality (slightly superior to CD) while the 12 bit mode records on two channels (stereo 1), leaving two channels free (stereo 2) for you to add new sound at a later date.

1. To switch to the 12 bit mode open the camera menu and select **AUDIO MODE**.
2. Select “12 bit” and close the menu.
 - “12 bit” is shown in the display for approximately 4 seconds.

Notes:

- You cannot add new sound to a tape using this camcorder.
- For details of playing back a tape that has new sound on stereo 2, see page 58.

Headphones and external microphone

For greater creative control over audio recording, you can connect an external microphone to the camera’s MIC terminal.

You can monitor the sound while recording by attaching stereo headphones to the camera’s terminal.

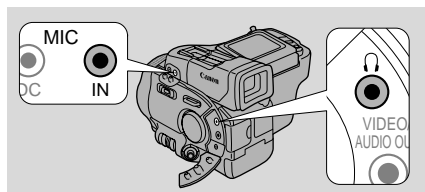

Wind screen



The camera has an automatic wind screen to prevent wind noise from interfering with the sound track. (It does not operate with an external microphone: WS **OFF** is displayed). Turn it off when you want the microphone to be as sensitive as possible.

1. Open the camera menu and point the arrow at **WIND SCREEN**.
2. Select the **OFF** setting and close the menu.
 - WS **OFF** is shown in the display.

Using the Full Range of Features

Setting the Self-Timer

E

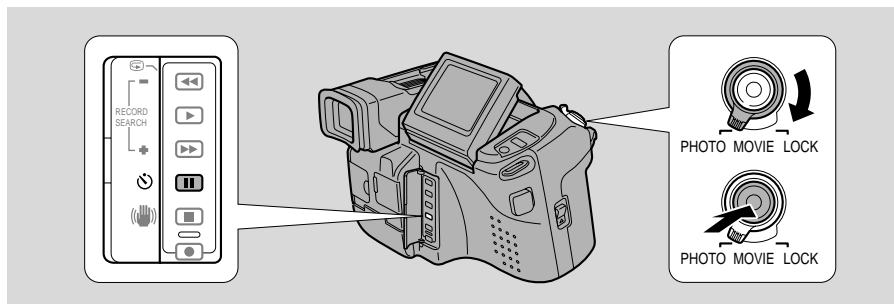

This is useful when you want to include yourself in the picture when recording.

1. Press the self-timer button.

- SELF TIMER appears in the display.

2 Press the start/stop button.

- The camera starts to record after a 10 second countdown period (or after 2 seconds when you use the remote control). The time remaining counts down in the display (e.g. “5 sec”).
- SELF TIMER disappears from the display when recording begins.

3. Press the start/stop button to end recording.

Notes:

- Initially the tally lamp flashes once a second, then just before recording starts it flashes more quickly for a few seconds before the camera starts to record.
- To cancel the self-timer press the self-timer button once more before recording. Once the countdown has begun, press the self-timer button to turn it off.
- Cancel the self-timer at any stage by switching the power off or turning the standby lever to LOCK.
- You cannot use the self-timer with the Negative-Positive Conversion program.
- In photo mode, set the self-timer in exactly the same way. The camera automatically adjusts the focus and exposure 2 seconds before the countdown is complete. The green ● mark is also displayed at this time.

Using a Canon Speedlite for Flash Photography (optional)

For SLR-style flash photography, use a Canon Speedlite 220EX or 380EX with the camera. Use the camera in exactly the same way as you would normally in photo mode (p. 31). Turn on the Speedlite using its main switch, and wait for it to charge. When you press the start/stop button halfway down, the camera sets the autofocus and the zoom is locked. Pressing the start/stop button fully down releases a pre-exposure flash burst that sets the flash intensity, exposure and white balance. The main flash is then sent out.

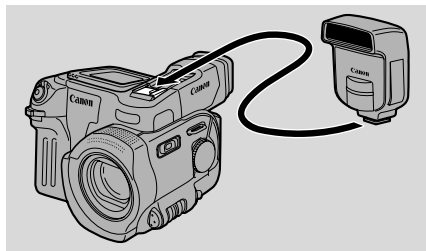

E

Flash Charging

While the flash is charging, a white \downarrow flashes in the display.

When the flash is fully charged a green \downarrow lights up constantly in the display.

- Although it is possible to record a still image while the Speedlite is still charging, the flash will not go off. In addition, the Speedlite cannot charge while you are holding the start/stop button halfway down.
- \downarrow disappears from the display while the camera records the still picture.

Notes:

- For full details of how to use the Speedlite, refer to its instruction manual.
- If you use the Speedlite in the shutter-priority (Tv) recording program, you can choose any shutter speed between 1/60 and 1/1000, but a shutter speed of 1/100 gives the best results.
- In the aperture-priority (Av) recording program, you can choose any F number, but an F number of less than F4 gives the best results.
- You cannot use the Speedlite with the:
 - Negative-Positive Conversion program.
 - FlexiZone AF. (When the \downarrow is displayed the FlexiZone frame returns to the center of the display).
 - Exposure Lock. (\downarrow goes out if you press the EXP wheel. It reappears when you turn the lock off, by pressing the EXP wheel once more).
- Turn the Speedlite unit off when you do not require the flash.
- The Speedlite should be connected directly to the OPTURA's accessory shoe: it can not be used with the SA-1 Adapter Bracket (optional).
- The 380EX Speedlite's internal automatic zoom is set to 28mm when attached to OPTURA. The guide number is set to 21.
- You are unable to use the Speedlite 380EX's bounce flash with OPTURA.

Adjusting Exposure Manually

E

Exposure lock

When you are recording in situations where the lighting may change suddenly, you can lock the exposure at the current level in order to control the brightness of the image.

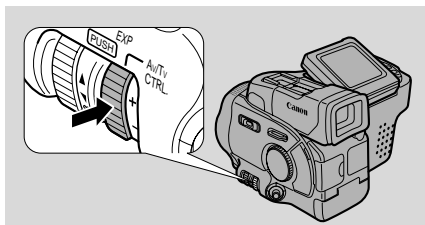

To lock the exposure, press the EXP wheel. Press it again to return to the automatically set exposure level.

Exposure adjustment

When the exposure is locked, you can adjust it manually, making the picture brighter or darker in order to deal with difficult lighting conditions, or to manipulate the mood of the scene. The camera's iris can be manually set to any position from fully closed to fully open.

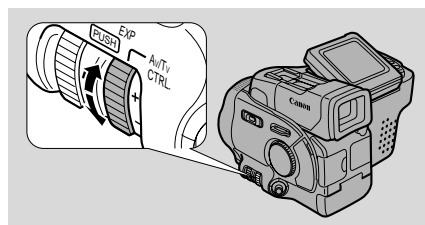

To make the recorded image brighter, turn the EXP wheel upwards (to a maximum of +11). This may be necessary if the background is very bright, or if the subject is lit from behind.

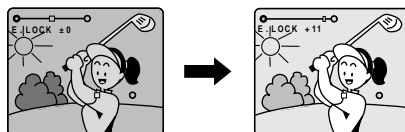

To make the recorded image darker, press the EXP wheel downwards (to a minimum of -11). This may be necessary if the background is very dark, or if the subject is spotlighted.

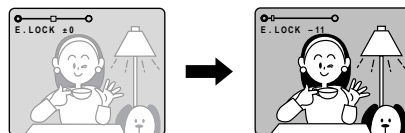

Notes:

- The standard exposure level depends on which recording program you have selected.
- Exposure lock is canceled if you change recording programs.
- You cannot use exposure lock or adjustment when the program selector is set to the  (Easy Recording) position.
- If you use the Negative-Positive Conversion program (p. 38) turn the exposure wheel in the opposite direction to that shown above. The display only shows the exposure level — the display bar is not shown.

Adjusting Focus Manually

E

The camera can focus automatically. All you have to do is point it, and whatever is in the center of the display will usually be in sharp focus. If it does not seem to be focusing well, it may be because the subject is not suitable for autofocus.

It also has two functions which give you more control over focusing.

FlexiZone AF

FlexiZone AF makes autofocus much more powerful. Using the FlexiZone controller, you can select any object that appears in the display, and the camera will bring it into focus.

FlexiZone AF is useful in the following situations:

When your main subject is not in the center of the display.



When you want to shoot a moving subject.



It also makes it easy to use “focus shift” techniques. You can direct the viewer’s attention by focusing first on one part of the scene, and then on another.



- 1. Make sure the camera is in record pause mode, and the program selector is set to any program except Easy Recording or Negative-Positive Conversion.**
- 2. Press and hold down the FOCUS wheel to display the FlexiZone frame.**
 - The FlexiZone control frame appears in the display.
- 3. Use the FlexiZone controller to move the frame over the subject.**
 - The controller can be moved in any direction. Press it repeatedly to move the frame little by little. Press and hold to move the frame quickly.
 - The camera adjusts the focus to suit the area inside the frame.
- 4. Press and hold down the FOCUS wheel once more to turn off FlexiZone AF.**
 - The FlexiZone frame disappears from the display.
 - This also turns the autofocus back on, if it had previously been turned off.

Focus lock

Press the FOCUS wheel to turn off autofocus. The focus remains locked at the point set by autofocus.

(AF OFF appears in the display.) You can now adjust the focus manually. Press the FOCUS wheel again when you want to return to autofocus.

- If you zoom in on your subject after turning off autofocus, it may not stay in focus. It is generally best to adjust the zoom first, and then the focus.

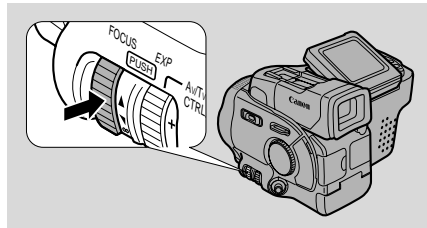

Manual focus

Use the FOCUS wheel to set the focus.

- Turn it downwards (towards ∞) to move the focus further away.
- Turn it upwards to bring the focus nearer.

You can also adjust the focus temporarily without turning autofocus off — in this case turn the manual focus wheel to set the focus (without pressing it down) and autofocus will start again as soon as you release the FOCUS wheel.

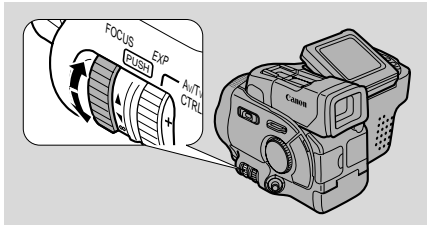

Notes:

- The manual focus setting is canceled if you:
 - Slide the POWER switch to VCR or OFF.
 - Select the (Easy Recording) program.
 - Turn the power off with the standby lever (or the camera turns itself off).
- When you are using the Easy Recording program, autofocus cannot be turned off, but you can override it temporarily by turning the FOCUS wheel.
- See “Troubleshooting” on p. 62 for a list of subjects which may not be suitable for autofocus.
- FlexiZone AF is canceled if you move the program selector to the or  position.
- You cannot use FlexiZone AF in photo mode.

Setting the White Balance

E

The camera's auto white balance system compensates for a wide range of lighting conditions. Although slight variations are unavoidable, colors will appear natural in virtually every situation.

In some cases, you will get better results by setting the white balance manually.

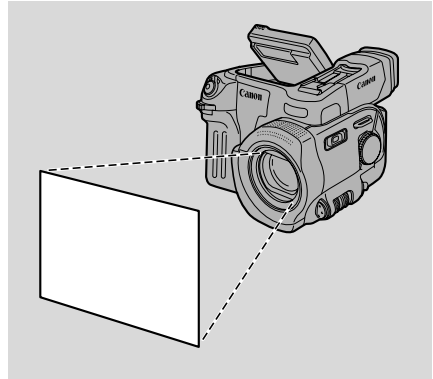

MENU
(see p. 25)

▶WHITE BAL...SET

1. **Open the camera menu and point the arrow at WHITE BAL.**
2. **Point the camera at a white object (such as a sheet of paper) and zoom in until it fills the display.**
3. **Select SET.**
 - The SET display flashes then remains lit.
 - Depending on the light source, the flashing may at times continue. The result will remain better than with the auto setting and you can continue recording.
4. **Close the menu.**
 - **WB** is shown in the display.

Setting the white balance manually will probably work better than auto white balance when shooting:

Subjects with one dominant color, such as sky, sea or forest.



Close-ups



In rapidly changing lighting conditions



In places lit by certain types of fluorescent or mercury vapor lights.



Notes:

- Turn the digital zoom off (if necessary) to set a more accurate white balance.
- If the lighting conditions change, reset the white balance by first returning to the AUTO setting, and then reselecting SET.
- Try to record with light from a single source. Correct white balance cannot be obtained for two types of lighting at once.
- You cannot set the white balance manually when the program selector is set to the (Easy Recording) program.
- When the program selector is set to the (Easy Recording) program or the POWER switch is set to the OFF position, the white balance setting returns to the AUTO.
- When the standby lever is set to LOCK without changing the program selector, the current white balance setting remains in the memory (except in the Negative-Positive Conversion program).

Editing to a VCR

E

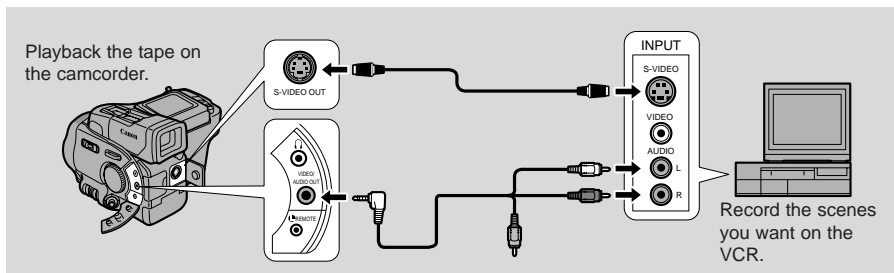

By connecting the camera to another VCR, you can edit your recordings in order to remove unwanted scenes — or combine different shots to create your own video productions.

Preparations

- 1. Connect the camera to the VCR.**
 - See “Connections for Playback on a TV screen” on p. 19.
- 2. Prepare the TV and VCR.**
 - Turn on the TV and set it to the video channel, or set the TV/VIDEO selector to VIDEO.
 - Turn on the VCR, and set its input selector to LINE. Load a blank cassette, and put the VCR in record pause mode.
 - See your TV and VCR instruction manuals for details.
- 3. Slide the camera’s POWER switch to VCR, and load your recorded cassette.**

Basic Recording

- 1. Find a point on your recorded cassette slightly ahead of the section you want to copy.**
- 2. Start to play it back while you monitor the picture on the TV.**
- 3. Start recording on the VCR as soon as the section you want to copy appears on the screen.**
- 4. Pause the VCR at the end of the section you want to copy, then stop playback on the camera.**
- 5. Repeat steps 1 to 4 until your edited recording is complete.**

Note:

- The quality of the edited tape will be slightly lower than that of the original.

DV terminal/connections

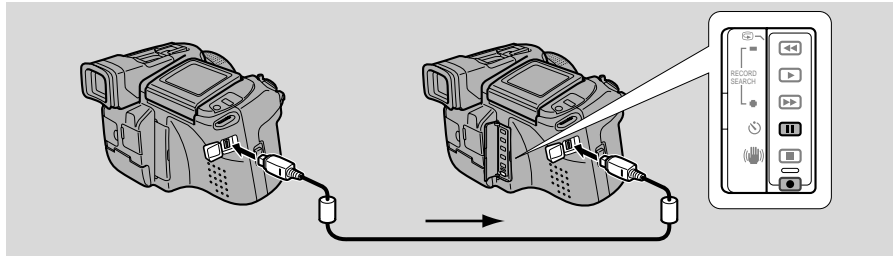

Digital video equipment fitted with this terminal lets you edit, copy and transfer data digitally, with imperceptible loss in image and sound quality. The DV terminal is for both line-in and line-out, since a single DV cable can handle data in both directions.

Use a Canon CV-150F DV cable to connect two digital devices together. When you are recording, make sure you connect the cable to the OPTURA before connecting the other end of the cable to the recording device. When you are recording to the OPTURA, slide the POWER switch to VCR and press its ● (record) and ■ (pause) buttons down simultaneously (“DV IN” appears in the display when you press “play” on the playback device). Then press its pause button to start/pause recording.



If the cables are not connected properly, the camera displays the caution “CHECK THE DV INPUT”.

- The image displayed by the camcorder that is being recorded to (for example on its LCD screen, an attached TV, or in its viewfinder) may become distorted during digital dubbing. The actual recording on the tape, however, is not affected.
- If you press the ● (record) button with the DV cable unconnected, the camera displays the caution “CHECK THE DV INPUT”. An anomalous image may also flash onto the screen.
- Blanks between recordings on the playback tape are recorded as anomalous images on the tape that is being recorded to.
- When operating either camcorder with the DV cable connected do not turn the power off.

REMOTE terminal

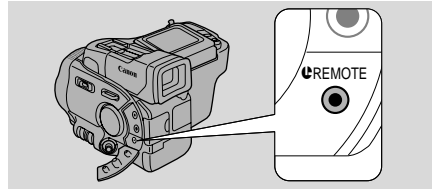
The  REMOTE terminal allows you to connect the camera to equipment such as the ED-100 Video Editor (p. 68). Some buttons on other editing equipment may operate differently from those on the camera.



-  (LANC) is a trademark. It stands for Local Application Control Bus System.
- We cannot guarantee the results when connecting to equipment not bearing the LANC  symbol.

Copyright signal

Certain pre-recorded software tapes are copyright protected. If you try to play back such a cassette, “COPYRIGHT PROTECTED PLAYBACK IS RESTRICTED” appears in the display for a few seconds and then the camera displays a blank blue screen; you cannot view the contents of the cassette. If you try to record from such a tape via the digital cable “COPYRIGHT PROTECTED DUBBING RESTRICTED” appears in the display; you cannot record the contents of the tape.

Preparing the Camera

E

Adjust the viewfinder

- In record pause mode, turn the viewfinder focusing wheel (focusing the display) to suit your eyesight.
- The viewfinder rotates through 80° to give a choice of shooting positions.

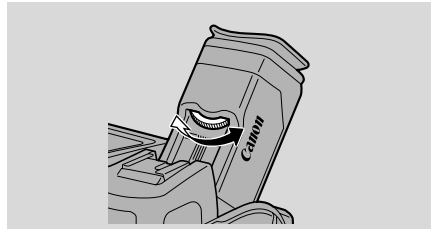

Remove the LCD cover

- Replace the cover when you are not using the LCD screen.

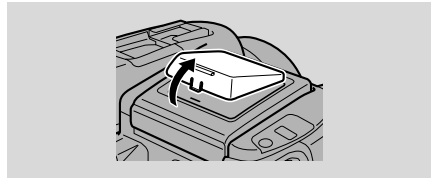

Prepare the lens cap

- Attach/remove the lens cap as shown.

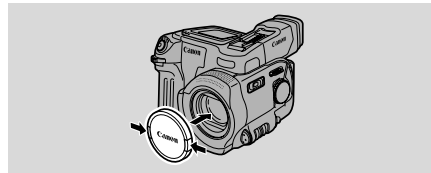

Attach the shoulder strap

- For extra security and portability, attach the shoulder strap before using the camera.
- Pass the ends through the attachment bars and adjust the length as shown.

Note:

- Be careful not to leave the viewfinder exposed to bright sunlight, or it will melt. (The light is concentrated by the viewfinder lens.)

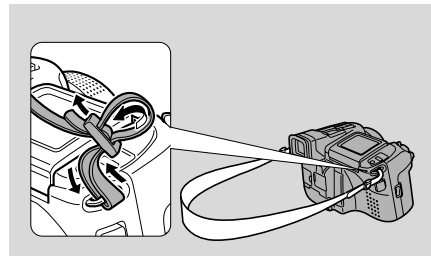

Additional
Information

Notes on Using the Batteries

E

Charging and recording times

- These times vary — the safest policy is always to have two or three times as many battery packs as you think you will need.
- You will get more recording time if you turn the camera off between shots, instead of leaving it in record pause mode.
- Recording time will be shorter than usual at low temperatures. You can use the battery pack between 32° and 104°F (0° to 40°C), but it works best between 50° and 86°F (10° to 30°C).
- If the battery pack starts to give you much less recording time than usual, it has reached the end of its life and must be replaced.

Battery pack	BP-914
Time needed for full recharge	2 hr. 30 mins
Maximum recording time	1 hr.

How much power is left?

The indicator in the display shows you approximately how much charge the battery pack has left:

Notes:

- “CHANGE THE BATTERY PACK ” appears in the display for 4 seconds when the power is completely exhausted. The empty battery mark then appears and starts to flash. The power indicator light also flashes.
- The indicator is not constant — different levels will be shown when you subject the battery pack and camcorder to different conditions.

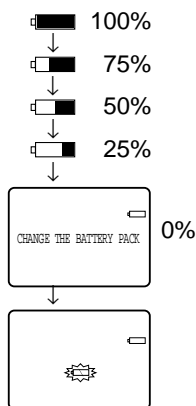

When to recharge

You can recharge a lithium ion battery pack whenever it is convenient. Unlike a conventional battery pack, it does not have to be fully discharged first. However, as the battery pack will naturally discharge itself over time, it is best to charge it the same day you plan to use it, or the day before.

Additional
Information

Taking care of the battery pack

Always attach the terminal cover.

- Do not allow any metal objects to touch the terminals, as this can cause a short circuit and damage the battery pack. Attach the terminal cover whenever the battery pack is not being used.

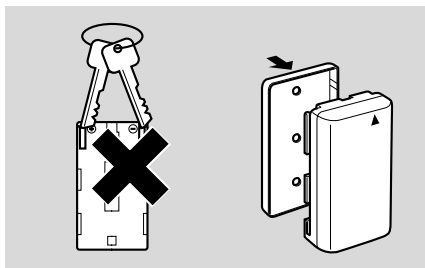

Keep the terminals clean.

- The camera, adapter or battery pack will not work properly if the terminals are dirty. Check them before use, and wipe them with a dry cloth or tissue if necessary.

Storing the battery pack

- If you do not use a battery pack for a period of more than a few months any remaining charge may cause damage to the battery pack, and reduce usage time. To prevent damage therefore, aim to use a battery pack's complete charge before storage.

Installing the backup battery

Slide off the battery cover and insert the CR2025 lithium battery (with the + side facing outwards) by pushing it slightly in to the right, before pressing the left side home. Slide the cover back into place.

This backup battery allows the camera to remember the date and time and other settings when the main power source is removed. It has a life span of about a year.

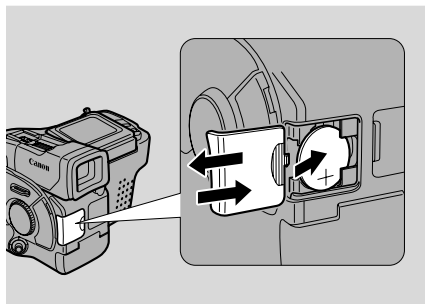

When it needs replacing (or if it has not been installed), the  mark flashes in the display. Remove the old battery by pushing it down and pulling it out from the left side. Make sure to attach a power source to the camera first, and turn it off using the standby lever. This way it will remember your chosen settings when you change the battery.

DANGER!**Treat the battery pack with care.**

- Keep it away from fire (or it might explode).
- Do not expose the battery pack to temperatures greater than 140°F (60°C). Do not leave it near a heater, or inside a car in hot weather, for example.
- Do not try to disassemble or modify it.
- Do not drop or knock it.
- Do not get it wet.

WARNING!

- The battery used in this device may present a fire or chemical burn hazard if mistreated. Do not recharge, disassemble, heat above 212°F (100°C) or incinerate.
- Replace the battery with a Sony, Sanyo or Panasonic CR2025, or Duracell DL2025. Use of another battery may present a risk of fire or explosion.

Cautions:

- Do not pick up the battery using tweezers or other metal tools — this will cause a short circuit.
- Wipe the battery with a clean, dry cloth to ensure proper contact.
- Keep the battery pack out of reach of children — if it is swallowed, contact a physician immediately, as the battery case may break down and the battery fluids damage the stomach and intestines.
- Do not disassemble, heat, or immerse the battery in water, to avoid the risk of explosion.

Setting the Audio Output

E

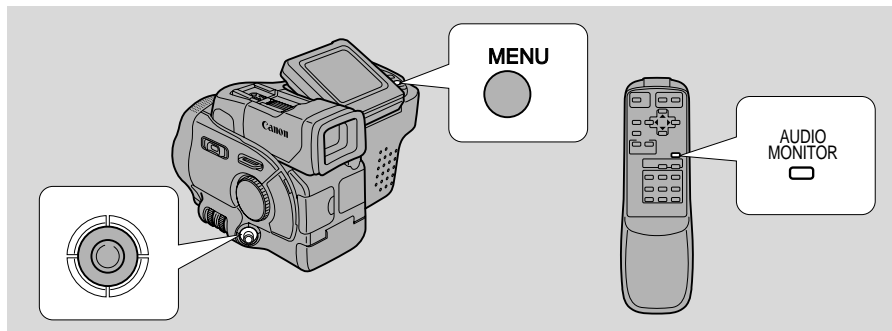

When you play back a tape that was recorded in 12 bit mode, you can set the audio output to play stereo 1 (the original sound), stereo 2 (any new sound, dubbed to the tape after recording), or mix the balance between the two. To simply choose stereo1 or stereo2, you do not need to release the fixed level (skip step number 2 below).

1. Set the camera to VCR mode.
2. Release the fixed level (for audio mixing only).



- a) Open the VCR menu and point the arrow at MIX SELECT.
- b) Select the VARIABLE setting and close the menu.

3. Choose the output.

You can only choose the output using the wireless controller.

- a) Press the wireless controller's AUDIO MONITOR button to display "STEREO1", "STEREO2", and "MIX", each in turn.

- Your choice is selected approximately 4 seconds after you last pressed the button.

If you choose "MIX" you can go on to mix the balance.

- Use the ◀/▶ cursor keys to choose the mix balance.

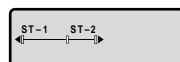

Notes:

- When you have chosen the output, "STEREO1", "STEREO2", or "MIX" is shown in the top left of the display. If you turn the power off the output (and display) is set to "STEREO1"
- You cannot mix the balance without first releasing the fixed level: the camera will show "FIXED" in the display.

Maintenance

Cautions

E

Avoid high temperatures and high humidity.

- Do not leave the camera inside a car in hot weather, for example.
- Be careful of heat radiating from video lighting equipment.
- Do not take the camera into a humid room.

Avoid sudden changes in temperature.

- If you take the camera from a cold place to a warm place, condensation may form on the lens and internal parts (see p. 61).

Do not point the lens or viewfinder at strong light sources.

- Never point it at the sun, and do not leave it aimed at a bright subject.
- Be especially careful when leaving the camera on a tripod.

Avoid magnetic or electric fields.

- Do not use the camera close to TV transmitters, portable communication devices or other sources of electric or magnetic radiation. They may cause picture interference, or permanently damage the camera.

Do not expose the camera to water.

- Cover the camera when you are recording in rain or mist.
- There is a risk of electric shock if water gets inside the camera — contact qualified service personnel as soon as possible.

Protect the lens.

- Sand and dust can damage the lens — be especially careful on windy days.

Handle the camera gently.

- Vibration or shock can cause damage.
- Do not use the viewfinder or LCD screen as a carrying handle.

Do not disassemble the camera.

- This is very dangerous as there is a risk of electric shock — if the camera does not function properly, take it to qualified service personnel.

Storage

If you do not intend to use the camera for some time, store it in an area which is free of dust and moisture, and where the temperature is no higher than 86°F (30°C). After storage, check each part and function of your camera to make sure everything is still working properly.

Note:

- These cautions also apply to accessories such as battery packs and cassettes.

Maintenance

Viewfinder/LCD (brightness)

- Adjust the brightness of the displays by turning the BRIGHT screws. For the viewfinder, you can find the screw on the inner side of the finder. For the LCD screen, you can reveal the screw on the back side of the screen by removing the small screw cover.

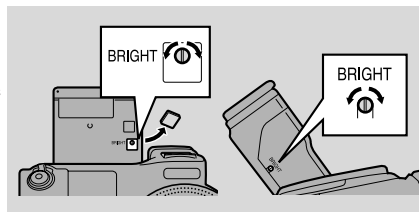

LCD

- Clean the LCD screen using a commercially available glass cleaner.
- Where there is a big change in temperature, moisture may form on the surface of the screen. Wipe clean with a soft, dry cloth.
- At low temperatures the display may appear to be much darker than usual. This is not a fault, and as the screen warms up the display will return to normal.

Camera body and lens

- Use a soft, dry cloth to clean the camera body or lens. Never use chemically treated cloth or volatile solvents such as paint thinner.

Video heads

- When mosaic-like noise appears on the playback picture, the video heads may be dirty. When the video heads are badly contaminated, the camera may show a blank blue screen.
- Clean the video heads using Canon's DVM-CL Digital Video Head Cleaning Cassette. If the "noise" remains, repeat the cleaning (up to maximum of five times).
- Do not use a wet-type cleaning cassette, as this can cause damage.



Using the camera abroad

Power sources

- You can use the compact power adapter to operate your camera and charge battery packs in any country where the electricity supply is between 110 and 240 V AC, 50/60 Hz. Contact your Canon dealer for information about plug adapters for overseas use.

TV playback

- Although you can always play back your recordings on the LCD screen, your camera can only be connected to TVs which use its NTSC system. This TV system is used in the following countries:
American Samoa, Bahama, Barbados, Bermuda, Bolivia, Canada, Chile, Columbia, Costa Rica, Cuba, Ecuador, El Salvador, Guam, Guatemala, Greenland, Haiti, Honduras, Jamaica, Japan, Korea, Mexico, Micronesia, Myanmar, Nicaragua, Panama, Peru, Philippines, Puerto Rico, Saint Lucia, Surinam, Taiwan, Trinidad and Tobago, USA, Venezuela.

Condensation

Condensation may form on the camera when it is moved from a cold place to a warm place. Using the camera while condensation is present can damage both the tape and the camera.

Condensation may become a problem:

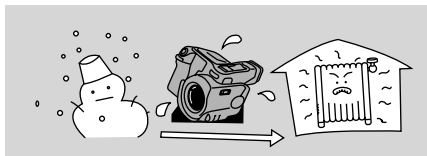

When you bring the camera from a cold place to a warm room

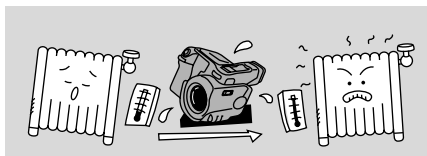

When a cold room is heated rapidly

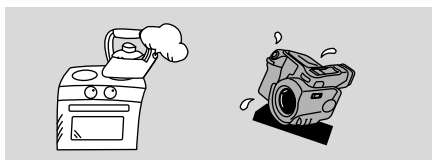

When the camera is left in a humid room

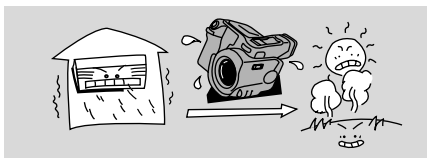



When the camera is taken from an air-conditioned room to a warm, humid place

Protecting the camera from condensation

- Before you bring the camera to a warm or humid place where condensation is likely to be a problem, unload the cassette and put the camera in a plastic bag. Wait until the camera reaches room temperature before you take it out of the bag.

What happens when condensation is detected

- “CONDENSATION HAS BEEN DETECTED” is displayed for approximately 4 seconds. Then, the power indicator flashes and the  mark flashes in the display. If there is a cassette in the camera, it stops automatically and “REMOVE THE CASSETTE” is displayed for approximately 4 seconds and then  flashes in the display.
- The camera may not detect the condensation immediately — the condensation warning may not start flashing for 10 to 15 minutes.
- You cannot load a cassette when condensation is detected.

What you should do

- Remove the cassette, leave the cassette compartment open, and turn the camera off.
- Leave it in a dry place until the condensation evaporates. After the condensation warning stops flashing, wait at least another hour before trying to use the camera.

Troubleshooting

E

Refer to this checklist first if you have any problems with your camcorder. Possible explanations are given for each problem on the list — turn to the page numbers in brackets for more information.

Make sure that the camera is properly connected if you are using it with a TV or VCR. Consult your dealer or service outlet if problems persist.

Recording/Playback

Problem

Cause and/or what to do about it

2 Nothing happens when I press the buttons

- The camera is not switched on (p. 12, 16).
- The cassette is not loaded or is set for erasure prevention (p. 10-11).
- The tape has reached the end.
- The battery pack is exhausted or not properly attached (p. 8, 9, 55).
- The function cannot be used in that recording program (p. 35).

2 The camera turned itself off.

- The camera was in record pause mode for more than about five minutes (p. 12).
- The battery pack is exhausted (p. 9).

2 The start/stop button doesn't work.

- The POWER switch is not set to CAMERA (p. 12).
- The standby lever is set to LOCK (p. 12).
- The cassette is not loaded or is set for erasure prevention (p. 10-11).
- The tape has reached the end.

2 There's no picture in the display.

- The POWER switch is not set to CAMERA (p. 12).
- The standby lever is set to LOCK (p. 12).

2 There's a blank blue screen in the display.

- You are attempting to play back or record from a copyright protected cassette (p. 53).
- The tape heads are badly contaminated (p. 60).

❑ The camera won't focus.

- The camera is on manual focus (p. 47).
- The viewfinder lens needs adjusting (p. 54)
- The lens is dirty (p. 60).

Note:

Some subjects are not suitable for autofocus. In these situations, you will often get better results using manual focus (see p. 47). Focus on something which is about the same distance away, lock the focus, and then point the camera at your original, hard-to-focus subject.



Horizontal stripes



Many subjects at different distances



Behind glass

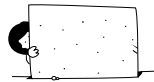

Without much contrast (e.g. a white wall)



Reflective surfaces (e.g. shiny car surfaces)



Fast moving objects



Slanted subjects



Dark subjects



Night scenes

Recording/Playback (Contd.)

Problem

- ❑ Some/all of the digital faders don't work
- ❑ The ► (play) button doesn't work
- ❑ There's a bright stripe on the screen.

Cause and/or what to do about it

- There are a number of restrictions on using the digital faders. Refer to the notes on p. 42.
- The POWER switch is not set to VCR (p.16)
- The cassette is not loaded (p.10).
- The tape has reached the end.
- When recording in dark places a bright light in the scene may cause a vertical light bar ("smear") to appear. This is a normal feature of camcorders.

Problem

- ❓ **The playback picture is rough (with mosaic-like noise)**
- ❓ **There's no picture on the TV screen, even though the tape is moving.**
- ❓ **There's no sound coming from the speaker during playback.**

Cause and/or what to do about it

- The video heads need cleaning (p. 60).
- The video heads need cleaning (p. 60).
- The TV/VIDEO selector on the TV isn't set to VIDEO (p. 19)
- If connected using the optional RF unit the video channel has not been selected.
- The speaker is switched off at the menu (p. 15).
- Headphones are being used.

Miscellaneous**Problem**

- ❓ **The wireless controller doesn't work.**
- ❓ **The tally lamp doesn't flash**
- ❓ **The power indicator is flashing.**
- ❓ **There are air bubbles inside the lens.**

Cause and/or what to do about it

- The remote sensor is turned off (p. 27).
- The batteries are dead or not inserted.
- It is turned off (p. 28).
- Check the screen displays (p. 73).
- This is unlikely, but may happen if you use the camera in places where the air pressure is low, in an airplane for example. The bubbles will disappear a week or so after you return the camera to normal atmospheric pressure.
- External interference may cause the camera's microprocessor to malfunction temporarily. If random letters appear in the display or if normal operation is interrupted, remove and then replace the power source (and if necessary, the back-up battery).
- Remove the cable and then reconnect it or turn the power off and back on again.

- ❓ **The camera malfunctions.**
- ❓ **The DV cable is connected correctly, but there's nothing in the display.**

The OPTURA System Diagram (Availability differs from area to area)

E

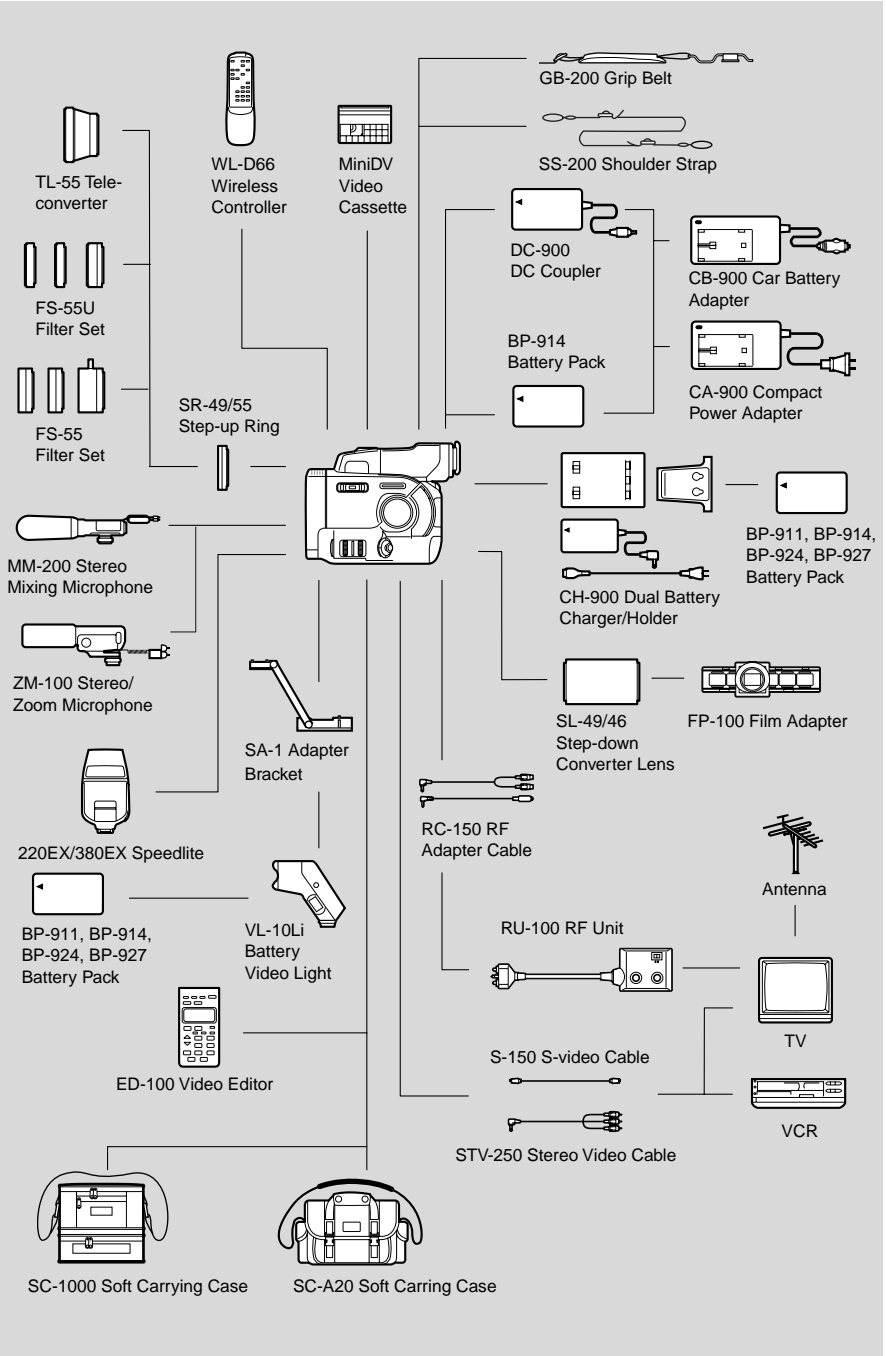

Additional Information

Optional Accessories

E

Battery pack

For use with the OPTURA. It is also available as an optional accessory.

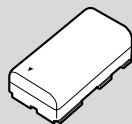

CB-900 Car Battery Adapter

Power your camera, or recharge battery packs on the move. The car battery adapter plugs into your car's cigarette lighter socket and runs off a 12-24 V DC negative ground battery.

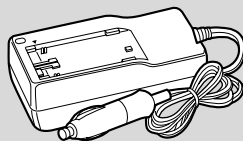

SR-49/55 Step-up ring

This makes it possible to use the 55 mm filters and converters (shown below) with OPTURA.



TL-55 Tele-converter

This tele-converter lens increases the focal length of the camera lens by a factor of 1.4. The zoom and autofocus operate as usual, so you can take full advantage of the extra range.

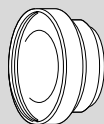

FS-55 Filter Set

Three special effects filters to add a creative touch to your recordings: multiple-image, R-cross and zoom-spot.

- Focus manually when using special effects filters.

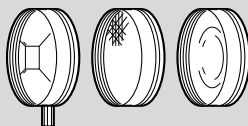

FS-55U Filter Set

Ultraviolet, neutral density and circular polarizing filters to help you take control of difficult lighting conditions.

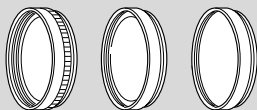

MM-200 Stereo Mixing Microphone

The MM-200 mixes live sound and music, so you can create the ideal sound track for your video productions.

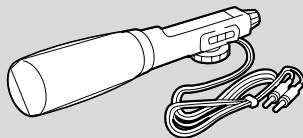

ZM-100 Stereo/Zoom Microphone

Features switchable stereo and zoom modes for extra recording control. In the stereo mode a dial adjust the apparent width of the stereo sound field, while in the zoom mode the dial adjusts the sensitivity of the microphone from near to far.

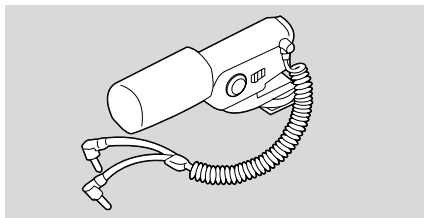
**VL-10Li Battery Video Light (available soon)**

This compact yet powerful video light can be used for both indoor and outdoor shooting.

- Lithium ion battery packs can be used to power the light. Approximate usage times are as follows:
 BP-911 45 min BP-924 90 min
 BP-914 50 min BP-927 100 min

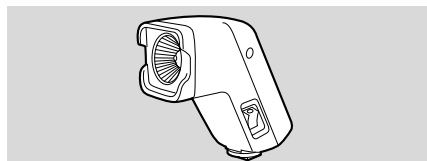
**SA-1 Adapter Bracket**

Attaches a video light or microphone securely to the camera.

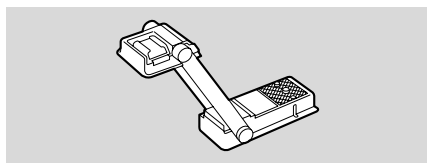
**CH-900 Dual Battery Charger/Holder (available soon)**

This holds two battery packs and can charge them both consecutively. It can then be connected directly to the OPTURA to give twice the playback time. It can also make use of the higher performance battery pack BP-927, to give up to 5hrs. recording time.

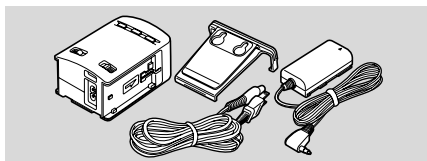
**GB-200 Grip Belt (available soon)**

This gives added comfort and security when handling OPTURA.

- Attaches onto the OPTURA via the tripod socket.

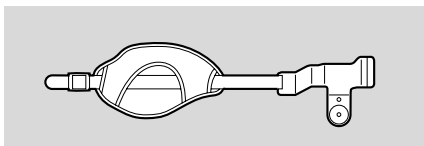

SC-1000 Soft Carrying Case

This lightweight bag keeps the camera within easy reach without weighing you down or getting in the way.

**SC-A20 Soft Carrying Case**

A handy camera bag with adjustable padded compartments and plenty of pockets for accessories.

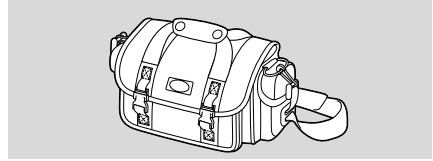
**RC-150 RF Adapter Cable**

This makes it possible to use the RU-100 RF Unit with OPTURA.

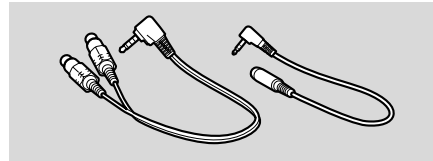
**RU-100 RF Unit**

This optional converter allows the camera to be connected to the antenna terminal of any TV. It can be a useful accessory while traveling, as you may need it if you want to connect the camera to a TV in your hotel room.

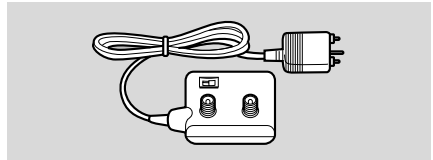
**ED-100 Video Editor**

This easy-to-use editor controls the camera and a video recorder simultaneously for fast, accurate assembly editing. Not only does it link up to any  (LANC) terminal, it can also learn the remote control signals used by most VCRs.

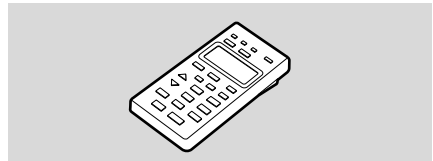
**220EX Speedlite/380EX Speedlite**

Attaches to the OPTURA's accessory shoe to give SLR-style flash photography.

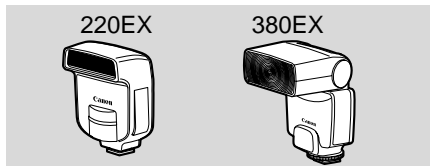

FP-100 Film Adapter

Use with your camcorder to record films and slides on video, load to an AV-compatible PC, or display on TV. Also, using the Advanced Photo System's optional accessory (film viewer IW-50), you can process Advanced Photo System film.

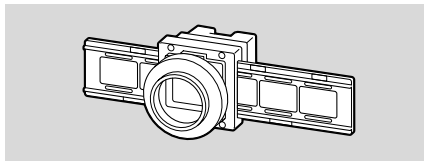

SL-49/46 Step-down Converter Lens

This makes it possible to use the FP-100 film Adapter with OPTURA.

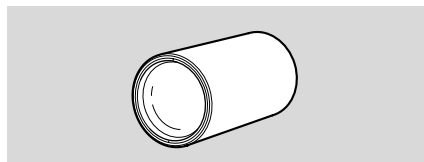

This mark identifies genuine Canon video accessories. When you use Canon video equipment, we recommend Canon-brand accessories or products bearing the same mark.

Provided accessories:

WL-D66 Wireless Controller	D83-0452-000	RC-150 RF Adapter Cable	D82-0515-201
CA-900 Compact Power Adapter	D85-0492-201	TL-55 Tele-converter	D78-0016-202
DC-900 DC Coupler	D85-0630-201	FS-55U Filter Set	D78-0018-202
BP-914 Battery Pack	D85-0842-201	FS-55 Filter Set	D78-0019-202
SS-200 Shoulder Strap	D81-0850-201	ED-100 Video Editor	D21-0112-201
S-150 S-video Cable	D82-0330-202	VL-10Li Battery Video Light	D86-0081-201
STV-250 Stereo Video Cable	D82-0516-000	JR7.2V 10WF Halogen Bulb	DY4-4530-000
Lens cap	D52-0070-000	MM-200 Stereo Mixing Microphone	D84-0060-201
DVM-E30 Digital Video Cassette	D36-0012-000	ZM-100 Stereo/Zoom Microphone	D84-0090-202
LCD Cover	D52-0060-000	SR-49/55 Step-up Ring	D56-0060-201
		220 EX Speedlite	C50-0741-201
		380 EX Speedlite	C50-0721-201
		SA-1 Adapter Bracket	D89-0500-202
		DVM-CL Digital Video Head Cleaning Cassette	D36-0032-201
		FP-100 Film Adapter	D59-0012-251
		SL49/46 Step-Down Converter Lens	D55-0040-201

Optional accessories:

CB-900 Car Battery Adapter	D85-0502-201
CH-900 Dual Battery Charger/Holder	D85-0772-201
BP-914 Battery Pack	D85-0842-201
BP-927 Battery Pack	D85-0852-201
SC-1000 Soft Carrying Case	D81-1200-001
SC-A20 Soft Carrying Case	D81-1232-201
RU-100 RF Unit	D82-0432-201

Finding Your Way Around OPTURA

E

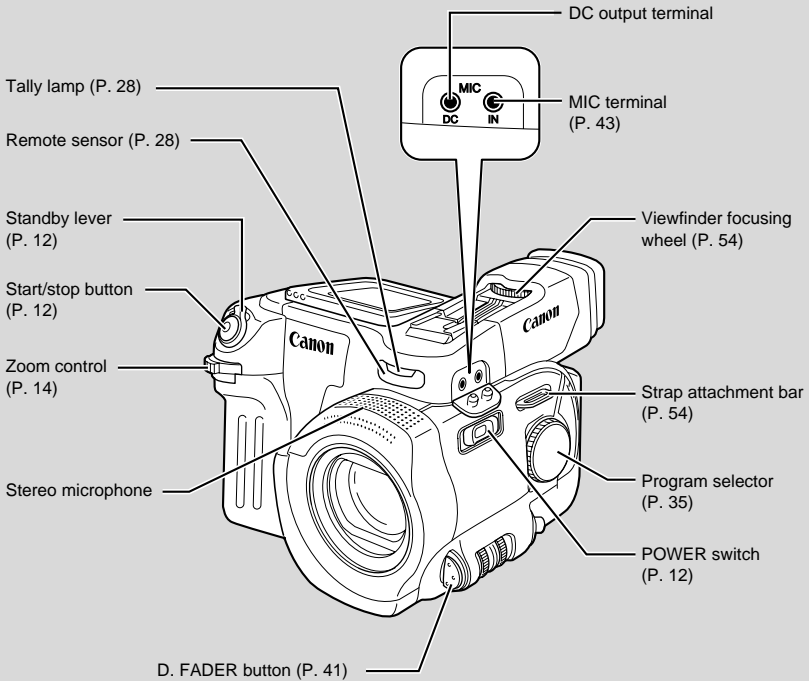

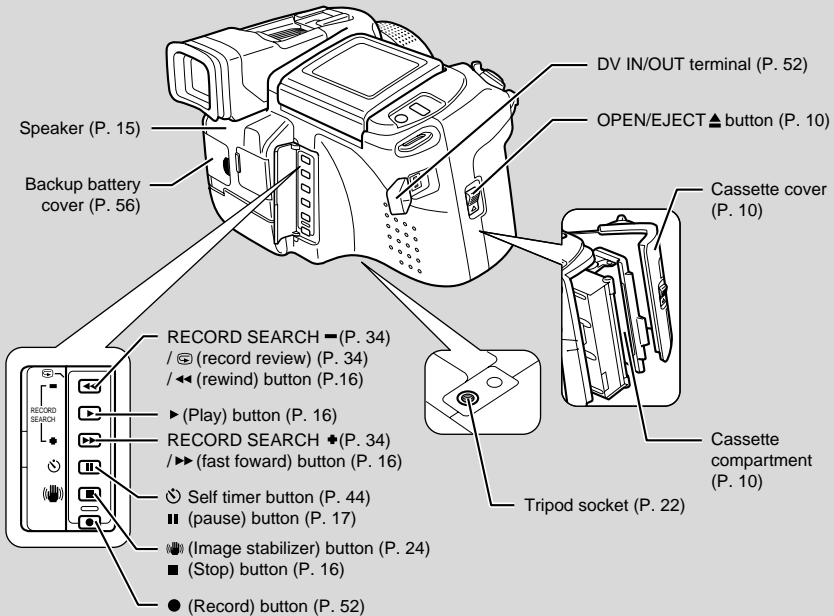
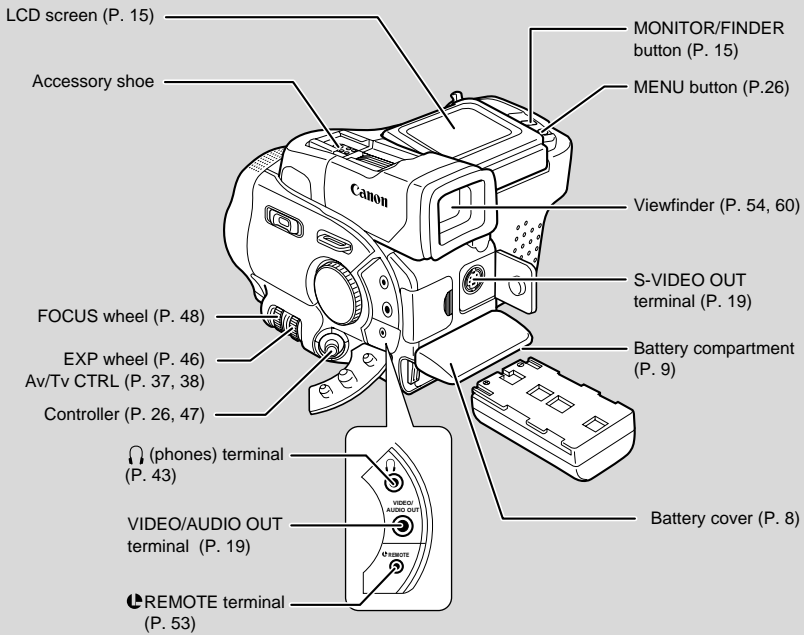

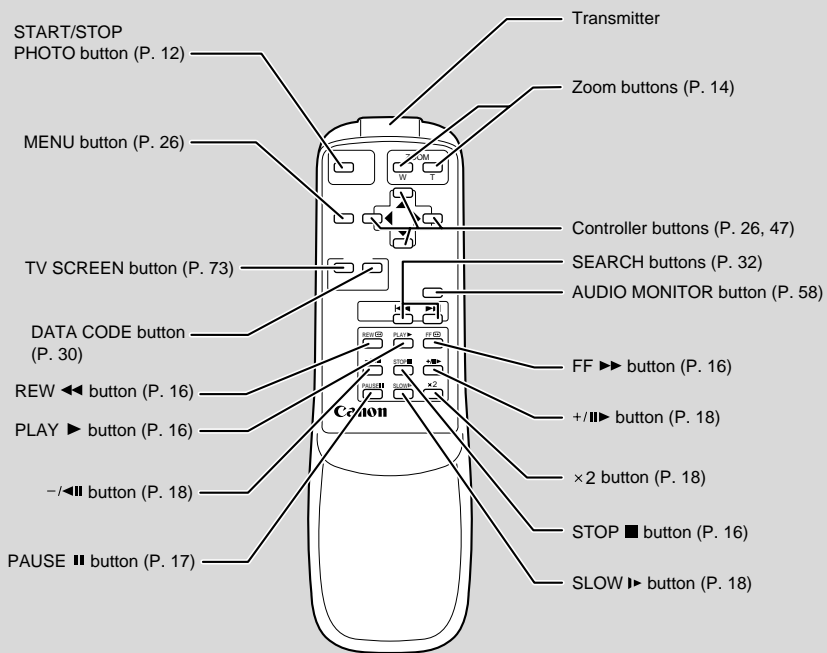



Screen Displays

E

To display the date and time on a connected TV, press the wireless controller's DATA CODE button.

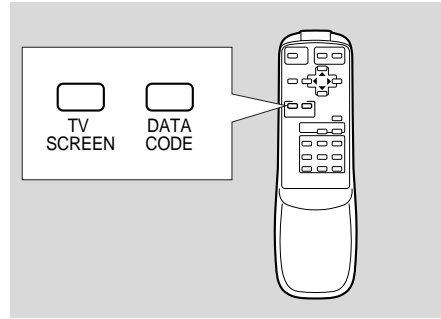
Press the wireless controller's TV SCREEN button to see the other displays on the TV screen. (The displays appear white on-screen.) They will not be added to any recordings you make with the camera.



 indicates a flashing display.

Record pause mode (p. 12)



The camera is ejecting the tape (p. 10).



Recording (p. 12)



The safety mechanism is activated. Unload the cassette and turn the camera off. Turn it on again and reload the cassette.



The backup battery is not properly installed, or needs replacing (p. 56).



Shows how much battery power remains (p. 55).



Recording mode (p. 13)



The battery pack is exhausted (p. 9, 55).



Playback is stopped (p. 16).



No cassette is loaded, or it is set for erasure prevention (p. 11).



Normal playback (p. 16)



Remaining tape (Green: more than 5 mins. Yellow: less than 5 mins. Red: final few secs).



Fast forward (p. 16)



...finally, it tells you when you have completely run out of tape.



Rewind (p. 16)



Fast forward playback (p.17)



Rewind playback (p.17)



Frame advance playback (p. 18)



Frame reverse playback (p. 18)



Additional Information

Playback pause
(forward and reverse)
(p. 17)

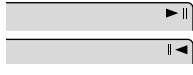

Slow playback
(forward and reverse)
(p.18)

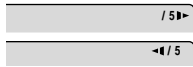

×2 playback (forward
and reverse) (p. 18)



×1 playback (forward
and reverse) (p. 18)

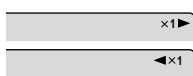

Photo Search
(p. 32)

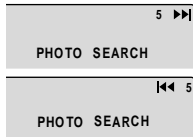
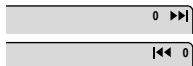
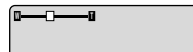

Photo search is
complete



Zoom display (p. 14):
Optical zoom



Optical plus digital
zoom



Zoom in

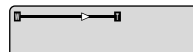

Zoom out

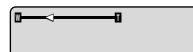

The image stabilizer
is turned on (p. 24).

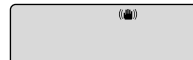

Camera menu (p. 25)

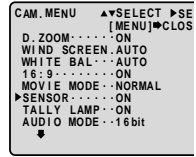

VCR menu (p. 25)

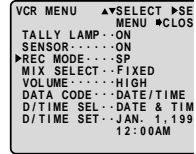

The remote sensor is
turned off (p. 27).



Self-timer countdown
(p. 44)

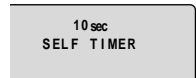

Negative-Positive
program menu (p. 39)

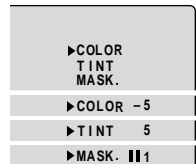

Audio mode (p. 43)



Data code (p. 30)



Photo mode (p. 31)

- Setting the AF/AE
 - mark flashes white



- AF/AE locked
 - mark lights up green



- Timer

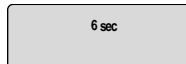

Movie mode (p. 33)



Recording programs (p. 35).



Manual focus is selected (p. 47).



White balance is set manually (p. 49).



The 16:9 effects: the display flashes when the effect is being selected, and appears steadily when it is activated (p. 42).

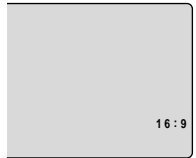

Digital faders functions. The display flashes when the function is being selected and appears steadily when it is activated (p. 41).

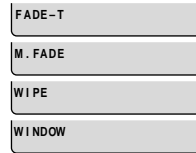

Flash is charging
⚡ mark flashes white (p. 45)
or charged



⚡ mark lights up green (p. 45)



The wind screen is turned off (p. 43).



Audio output (p. 58)



Mix balance (p. 58)

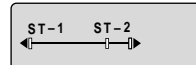

Manual exposure display (p. 46):
Exposure locked

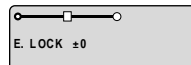

Brighter than standard exposure level

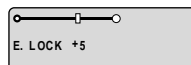

Mix select has not been released at the menu (p. 58)



Darker than standard exposure level

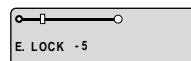

Condensation warning (p. 61)

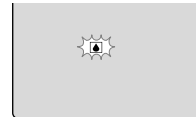

Time Code

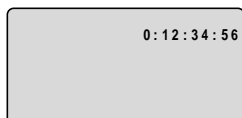

This records counter information, including hour, minute, second, and frame number on a special data code area on the tape itself. It is reset automatically when a new tape is loaded.

Recording reminder

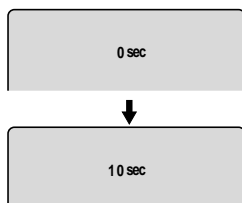

When you start recording, the camera counts from 0SEC to 10SEC. Shots which are shorter than 10 seconds may be difficult to edit later. On the other hand, if you are not planning to edit the recording, remember that a shot which does not contain action should generally last no longer than 10 seconds.

Caution phrases

The camera displays various caution phrases — they appear for 4 seconds before disappearing.

Appears each time you turn the power on, until you set the date and time (p. 29).

SET THE DATE AND TIME

Appears when the battery pack is exhausted (p. 9, 55).

CHANGE THE BATTERY PACK

Appears when the tape has reached the end.

TAPE END

Refer to page 11.

THE TAPE IS SET FOR
ERASURE PREVENTION

Appears when you press the ● (record) button if the DV cable is not connected properly (p. 52).

CHECK THE DV INPUT

Refer to page 61.

CONDENSATION
HAS BEEN DETECTED

Appears as a warning to protect the tape and also when condensation is detected. Remove the tape as soon as possible after the camera has displayed the caution.

REMOVE THE CASSETTE

Refer to page 53.

COPYRIGHT PROTECTED
PLAYBACK IS RESTRICTED

Refer to page 53.

COPYRIGHT PROTECTED
DUBBING RESTRICTED

Specifications

OPTURA

E

Power Supply (rated): 7.2 V DC

Power Consumption (while recording with the AF turned on): 7.1 W

Television system:

EIS standard (525 lines, 60 fields)
NTSC color signal

Video recording system:

2 rotary heads, helical scanning
DV system (Consumer digital VCR SD system)

Digital component recording

Audio recording system: PCM digital sound: 16 bit (48kHz/2ch), 12 bit (32kHz/4ch)

Image sensor: 1/3" Progressive Scan CCD (charge coupled device)
380,000 pixels (360,000 effective pixels)

Tape format: Videocassettes bearing the **MiniDV** mark.

Tape speed:

SP: $\frac{3}{4}$ ips (18.81 mm/s);
LP: $\frac{1}{2}$ ips (12.56 mm/s)

Maximum recording time:

SP: 60 minutes (with a 60 min. cassette);
LP: 90 minutes (with a 60 min. cassette)

Fast forward/rewind time:

Approx. 2 min. 50 sec. (with a 60 min. cassette)

Lens: F/1.8–3.2, 14× power zoom, 5.2–72.8mm

Focusing system: TTL autofocus, manual focusing possible

Minimum focusing distance: $\frac{3}{8}$ inch (1 cm) on maximum wide angle

Maximum shutter speed:

$\frac{1}{2}$, 000 sec

Minimum illumination: 2.5 lx (using the slow shutter at $\frac{1}{8}$ sec)

Recommended illumination:

More than 100 lx

Filter diameter: 49mm

Viewfinder: 0.55-inch, color LCD (approx. 113,000 pixels)

LCD screen: 2 in measured diagonally (5.1 cm), 113,000 pixels (approx.)

Microphone: Stereo electret condenser microphone

DV Terminal: Special 4-pin connector (conforms to IEEE1394)

Output level:

Video terminal: 1 Vp-p/75 ohms unbalanced

S-video terminal: 1 Vp-p (Y signal), 0.286 Vp-p (C signal)

Audio terminal: –10dBV, less than 3 kohms, unbalanced

Operating temperature range:

32–104 °F (0–40 °C)

Dimensions: 5 $\frac{7}{16}$ × 4 $\frac{3}{16}$ × 5 $\frac{1}{4}$ in (138 × 106 × 133mm)

Weight: 2lbs approx. (930g)

BP-914 Battery Pack

Battery type: Rechargeable lithium ion battery

Rated voltage: 7.2 V DC

Operating temperature: 32°–104°F (0°–40°C)

Battery capacity: 1,350 mAh

Dimensions: 1 $\frac{1}{2}$ × 1 $\frac{3}{16}$ × 2 $\frac{13}{16}$ in (38.2 × 20.5 × 70.5 mm)

Weight: 3 $\frac{3}{8}$ oz (96 g)

Weight and dimensions are approximate. Errors and omissions excepted.

Subject to change without notice.

Canon is a trademark of Canon Inc.

Index

E

- A**
 - Abroad, Using the Camera, 60
 - Accessories, 6, 66
 - Adapter, AC, 8
 - AE Programs, 35
 - Audio Output, 58
 - Audio Recording and Playback, 44
 - Audio/Video Terminals, 19
 - Auto, 36
 - Autofocus, 47
 - Av/Tv CTRL, 37, 38
- B**
 - Backup Battery, 56
 - Basic Recording, 12
 - Battery Pack, 9
- C**
 - Cables, 6, 19
 - Cassettes, 10
 - Charging the Battery Pack, 9
 - Choosing a Recording Program, 35
 - Cleaning the Camera, 60
 - Condensation, 61
 - Connection to TV or VCR, 19
- D**
 - Date and Time, 29, 30
 - Displaying Data Code, 30
 - DC Coupler, 8
 - Digital Faders, 40
 - Digital Video, 7
 - Digital Zoom, 14
 - DV terminal, 52
- E**
 - Easy Recording, 35
 - Editing, 51
 - Exposure, 46
 - External Microphone, 43
- F**
 - Fade, 40
 - Fast Forward, 17
 - Feedback, 20
 - Finding Your Way Around
the OPTURA, 70
 - Flash photography, 45
 - FlexiZone control, 47
 - Focusing, 47
- H**
 - Head Cleaning, 60
 - Headphones, 43
- I**
 - Image Stabilizer, 24
 - Introducing the OPTURA, 7
- L**
 - LANC, 53
 - LCD Screen, 15
 - Lens Cap, 54
 - Loading Cassettes, 10
 - LP Modes, 13
- M**
 - Maintenance, 59
 - Making Better Videos, 22
 - Manual Exposure Control, 46
 - Manual Focus, 47
 - Menus, 25
 - Movie Mode, 33
- N**
 - Negative/Positive Conversion, 38
- O**
 - Optical Image Stabilizer, 24
 - Optional Accessories, 66

P

Pause, Record, 12
Photo Mode, 31
Photo Search, 32
Playback, 16
Playback Connection, 19
Playback pause, 17
Power Adapter, 8
Powering your camcorder, 8
Preparing the Camera, 54
Problems, 62

R

Recharging the Battery Pack, 55
Recording, 12
Recording Programs, 35
Record Pause Mode, 12
Record Review, 34
Record Search, 34
Remote Control, 27
Remote Sensor, 27
Rewind, 16

S

Sand & Snow, 36
Screen Displays, 73
Self-Timer, 44
Shoulder Strap, 54
16:9, 42
Specifications, 77
Speedlite, 45, 68
Spotlight, 36
SP Modes, 13
Storage, 59
S-video, 19
System Diagram, 65

T

Tally Lamp, 28
Tape Protection, 11
Telephoto, 14
Temperature, 57, 59
Time Code, 76
Tripod, 22
Troubleshooting, 62
TV, 19, 73

U

Using the Camera Abroad, 60
Using the Menus, 25

V

VCR, 19, 51
Videocassettes, 10
Video Channel, 21
Video heads, 60
Viewfinder, 54, 60

W

Wide-angle, 14
Widescreen TV, 42
Wind Screen, 43
Wipe, 40
Wireless Controller, 27
Video heads, 60
White Balance, 49

Z

Zooming, 14



CANON INC.

30-2, Shimomaruko 3-chome, Ohta-ku, Tokyo 146, Japan

U.S.A. ————— **CANON U.S.A., INC. NEW JERSEY OFFICE**
100 Jamesburg Road, Jamesburg, NJ 08831 USA

CANON U.S.A., INC. CHICAGO OFFICE
100 Park Blvd., Itasca, IL 60143 USA

CANON U.S.A., INC. LOS ANGELES OFFICE
15955 Alton Parkway, Irvine, CA 92718 USA

CANON U.S.A., INC. HONOLULU OFFICE
1020 Auahi Street, Bldg. #8, Honolulu, HI 96814 USA

- **If you have any questions, call the Canon U.S.A. Information Center toll-free on 1-800-828-4040 (U.S.A. only).**

CANADA ————— **CANON CANADA INC. NATIONAL HEADQUARTERS**
6390 Dixie Road, Mississauga, Ontario L5T 1P7

CANON CANADA INC. CALGARY
2828, 16th Street, N.E. Calgary, Alberta T2E 7K7

CANON CANADA INC. MONTREAL
5990 Côte de Liesse, Quebec H4T 1V7

- **If you have any questions, please call toll-free in Canada 1-800-828-4040.**
- **Si vous avez des questions, veuillez téléphoner sans frais au Canada 1-800-828-4040.**

MEXICO ————— **CANON MEXICANA, S. DE R.L. DE C.V.**
Calzada de Tlalpan 479, Col. Alamos C.P. 03400
Deleg. B. Juárez, México, D.F., México

CENTRO Y SURAMÉRICA ————— **CANON LATIN AMERICA, INC.**
6505 Blue Lagoon Drive Suite 325 Miami FL 33126 USA

ASIA ————— **CANON HONGKONG COMPANY LTD.**
10/F, Mirror Tower, 61 Mody Road, Tsimshatsui East, Kowloon, Hong Kong

Free Manuals Download Website

<http://myh66.com>

<http://usermanuals.us>

<http://www.somanuals.com>

<http://www.4manuals.cc>

<http://www.manual-lib.com>

<http://www.404manual.com>

<http://www.luxmanual.com>

<http://aubethermostatmanual.com>

Golf course search by state

<http://golfingnear.com>

Email search by domain

<http://emailbydomain.com>

Auto manuals search

<http://auto.somanuals.com>

TV manuals search

<http://tv.somanuals.com>