



*INSTALLATION, OPERATION AND
SERVICE MANUAL*



**12 Gallon Kettle on
Stand**

MODEL: SD650K12-BC

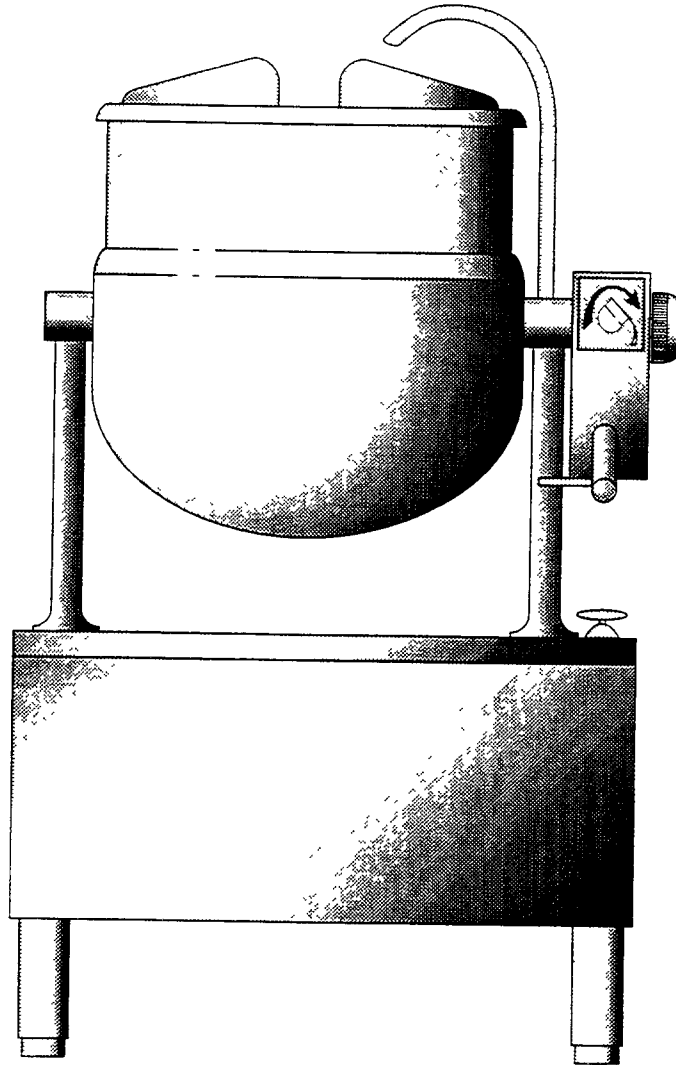

CLEVELAND RANGE INC.
1333 East 179th St. Cleveland,
Ohio U.S.A. 44110
Toll Free 1-800-338-2204

TABLE OF CONTENTS

Installation

<i>General</i>	1
<i>Inspection</i>	1
<i>Shipping Damage Instruction</i>	1
<i>Installation</i>	1
<i>Clearance Requirements</i>	1
<i>Steam</i>	1
<i>Condensate</i>	1
<i>Water</i>	1
<i>Final Installation Check</i>	1
<i>Operation</i>	2
<i>Care & Cleaning</i>	2
<i>Steam Control Assembly</i>	3-4
<i>Tilting Gearbox Assembly</i>	5-6
<i>Plumbing Assembly</i>	7-8
<i>General Maintenance</i>	...9
<i>Pressure Relief Valve Testing Procedure</i>	9
<i>Steam Trap</i>	9
<i>Warranty</i>	9
<i>Troubleshooting Guide</i>	10
<i>Steam Flow Rating of Steam Generators</i>	10
<i>Steam Flow Rating Requirements for Kettles</i>	10

Operating, Care & Cleaning Instructions Service Parts

Maintenance

INSTALLATION

GENERAL

Installation of the unit must be accomplished by qualified installation personnel working to all applicable local and national codes. Improper installation of product could cause injury or damage. This unit is built to comply with applicable standards for manufacturers. Included among those approval agencies are UL, NSF ASME/Ntl Bd, CSA, ETL, CE, and others. Many local codes exist, and it is the responsibility of the owner/installer to comply with these codes.

INSPECTION

Before uncrating, visually inspect the unit for evidence of damage during shipping. If damage is noticed, do not unpack the unit, follow shipping damage instructions.

SHIPPING DAMAGE INSTRUCTIONS

If shipping damage to the unit is discovered or suspected, observe the following guidelines in preparing a shipping damage claim:

1. Write down a description of the damage or the reason for suspecting damage as soon as it is discovered. This will help in filling out the claim forms later. If possible, take a polaroid picture.
2. As soon as damage is discovered or suspected, notify the carrier that delivered the shipment.
3. Arrange for the carrier's representative to examine the damage.
4. Fill out all carrier claims forms and have the examining carrier sign and date each form.

INSTALLATION

Carefully remove unit from shipping carton and position unit in desired location. Place a carpenter's level on the kettle rim and level the stand using the level adjustable feet.

Install service connections as required.

CLEARANCE REQUIREMENTS

For complete details see the SPECIFICATION DRAWING at the back of this manual.

CLEARANCE REQUIREMENTS TO COMBUSTIBLE AND NONCOMBUSTIBLE SURFACES:

Right - 4' Left - 0 Back - 0

STEAM

All steam plumbing to and from the kettle and steam boiler should be thoroughly cleaned and inspected for dirt and debris before final connection to the kettle is made.

Kettles require a minimum 1/2" IPS pipe, 10-45 psi steam pressure. If the steam supply pressure exceeds 45 psi, a pressure reducing valve is required. The steam inlet is at the right side of the kettle, as seen from the front.

CONDENSATE

The condensate line is limited to a maximum rise of 10 feet in order for the steam pressure to adequately force the condensate through the plumbing. Any higher rise requires a pump.

WATER

The water faucet, with swing spout, requires 1/2" OD copper tube plumbing for cold water supply to the faucet.

FINAL INSTALLATION CHECK

1. Partially fill the kettle with water.
2. Slowly turn the steam supply valve's knob to the open position.
3. Release the safety valve ensuring that the steam escapes freely. Stay clear of steam exhaust when releasing the safety valve.
4. Observe that the water in the kettle comes to a boil.
5. Close the steam supply valve.
6. Drain off the water by tilting the kettle.

OPERATION, CARE & CLEANING INSTRUCTIONS

**CLEVELAND STEAM COOKING EQUIPMENT IS INTENDED FOR COMMERCIAL USE
ONLY BY PROFESSIONALLY TRAINED PERSONNEL.**

OPERATION

1. Ensure that there is an adequate steam supply to the kettle.

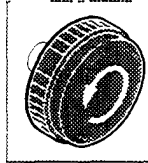

2. Turn the steam control valve to the final open position by turning the knob counter-clockwise, then allow the kettle to preheat.

NOTE: When cooking egg and milk products, the kettle should NOT be preheated, as products of this nature adhere to hot cooking surfaces. These types of foods should be placed in the kettle before heating is begun.

3. Fill kettle with product to desired level.

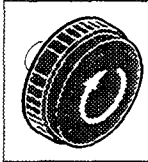

4. When the product has reached the desired temperature, regulate the heat, as required, by turning the steam control valve for less steam, and therefore, a lower temperature.

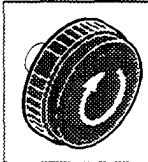

5. When cooking is complete, close the steam control valve by turning the knob.

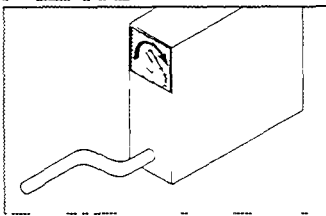

6. To empty kettle, turn handle clockwise.

FOR KETTLE/STEAMER COMBINATIONS:

If the boiler in a steamer is supplying steam to a kettle, always heat the kettle first. After the kettle contents are heated and the boiler's steam pressure returns to normal, the steamer may be used. Pressure steamer compartments should be sequentially started, and preheated before cooking.

NOTE: As with cleaning food soil from any cookware, an important part of kettle cleaning is to prevent foods from drying on. For this reason, cleaning should be completed immediately after cooked foods are removed. Please read the following "Care and Cleaning" instructions for detailed kettle and stand washing procedures.

CARE AND CLEANING

Your kettle must be cleaned regularly to maintain its fast, efficient cooking performance, and to ensure its continued safe, reliable operation.

WARNING: Do not use chloride base detergents.

1. Prepare a warm water and mild detergent solution in the kettle.
2. Remove food soil inside the kettle using a nylon brush. Do not use a metal bristle brush as this may permanently damage the kettle's stainless steel surface.
3. Loosen food which is stuck to the kettle by allowing it to soak at a low temperature setting.
4. Tilt kettle forward to drain wash water.
5. Rinse kettle interior thoroughly, then drain the rinse water.
6. Using mild soapy water and a damp sponge, wash the exterior of the kettle and stand rinse, and dry.
7. Leave the cover off when the kettle is not in use.

NOTE: For more difficult cleaning applications one of the following can be used: alcohol, baking soda, vinegar, or a solution of ammonia in water. Avoid the use of chloride cleansers, which may damage the kettle's or stands stainless steel surface.

WARNING: Steel wool should never be used for cleaning the cooking chamber of the kettle. Particles of steel wool become embedded in the cooking surface and rust, which may corrode the stainless steel.

Steam Control Assembly

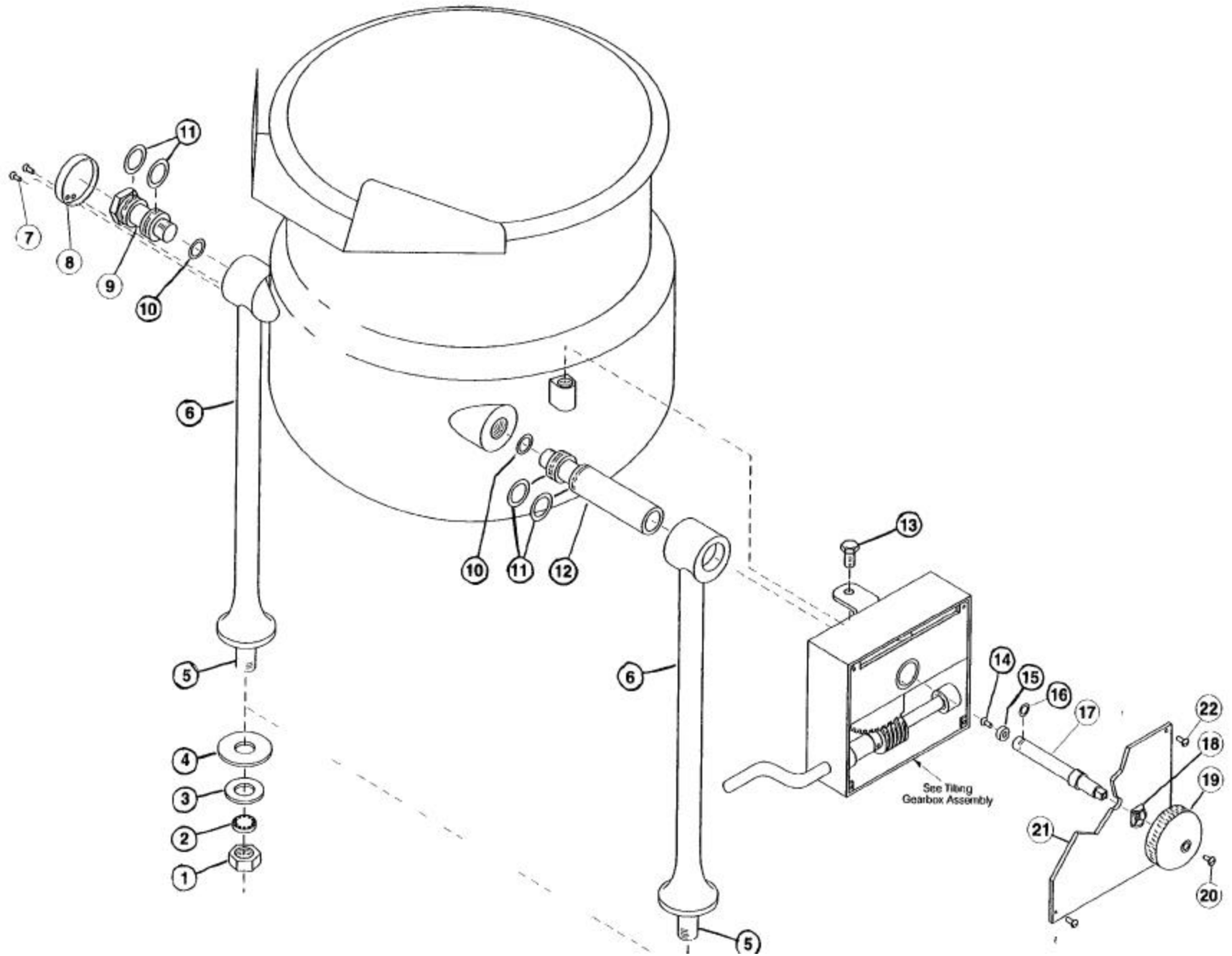

STEAM CONTROL ASSEMBLY

ITEM NO.	PART NO.	DESCRIPTION	QTY.
1	KE52697	Lock Nut, 1/2" NPS	2
2	FA32500	Lockwasher	2
3	FA30502	Washer, satin coat	2
4	KE50467	Washer, Foot	2
5	KE50463	Service Pipe	2
6	KE00203	Leg Assembly	2
7	FA11056	Binding Head Screw, 6-32 x 1/2" lg	2
8	KE50458	End Cap, condensate return	1
9	KE504551	Trunnion, condensate return	1
10	FA00018	"0" Ring	1
11	FA00117	"0" Ring	4
12	KE54752	Trunnion	1
13	FA11509-1	Bolt, 1/2-13x3/4"lg	1
14	FA11089	Binding Head Screw, 8-32 x 1/4" lg	1
15	KE51713	Washer, steam valve	1
16	FA00110	"0" Ring	1
17	KE50459-1	Operating Stem	1
18	KE51888	Retaining Washer	1
19	SE00028	Steam Control Knob (includes Item #18 & 20)	1
20	FA11092	Binding Head Screw, 8-32 x 1/2" lg	1
21	KE54729	Gear Box Cover	1
22	FA11146	Binding Head Screw, 8-32 x 3/8"	4

TILTING GEARBOX ASSEMBLY

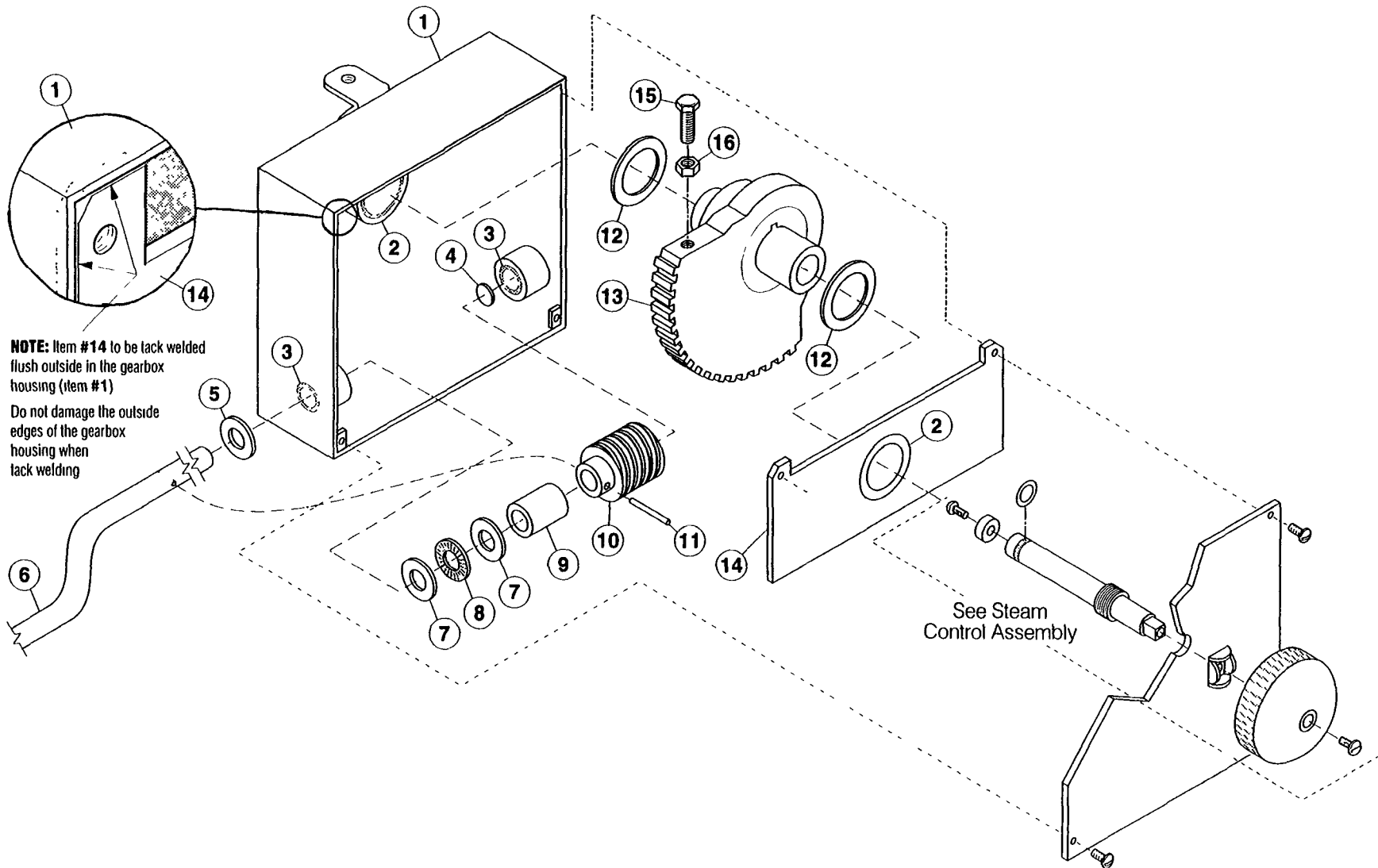

TILTING GEARBOX ASSEMBLY

<i>ITEM NO.</i>	<i>PART NO.</i>	<i>DESCRIPTION</i>	<i>QTY.</i>
1 -16	KE02062-1	Tilting Gearbox Assembly	1
1	KE02060	Gearbox Housing	1
2	KE50198	Bearing, trunnion	2
3	KE54739-2	Bearing, tilt shaft	2
4	KE54737	End Housing Spacer, tilt shaft bronze	1
5	KE54738-3	Washer	1
6	KE50306-1	Tilt Shaft	1
7	KE52192	Bearing Washer	2
8	KE52191	Bearing	1
9	KE50426-3	Spacer, worm gear	1
10	KE50315	Worm Gear	1
11	FA95005	Tension Pin	1
12	KE54738-1	Washer	2
13	KE02059	Segment Gear and Spacer Assembly	1
14	KE02061	Trunnion Bearing Housing Holder Assembly c/w Bearing	1
15	FA10485	Hex Head Bolt	1
16	FA20008	Hex Nut	1

PLUMBING ASSEMBLY

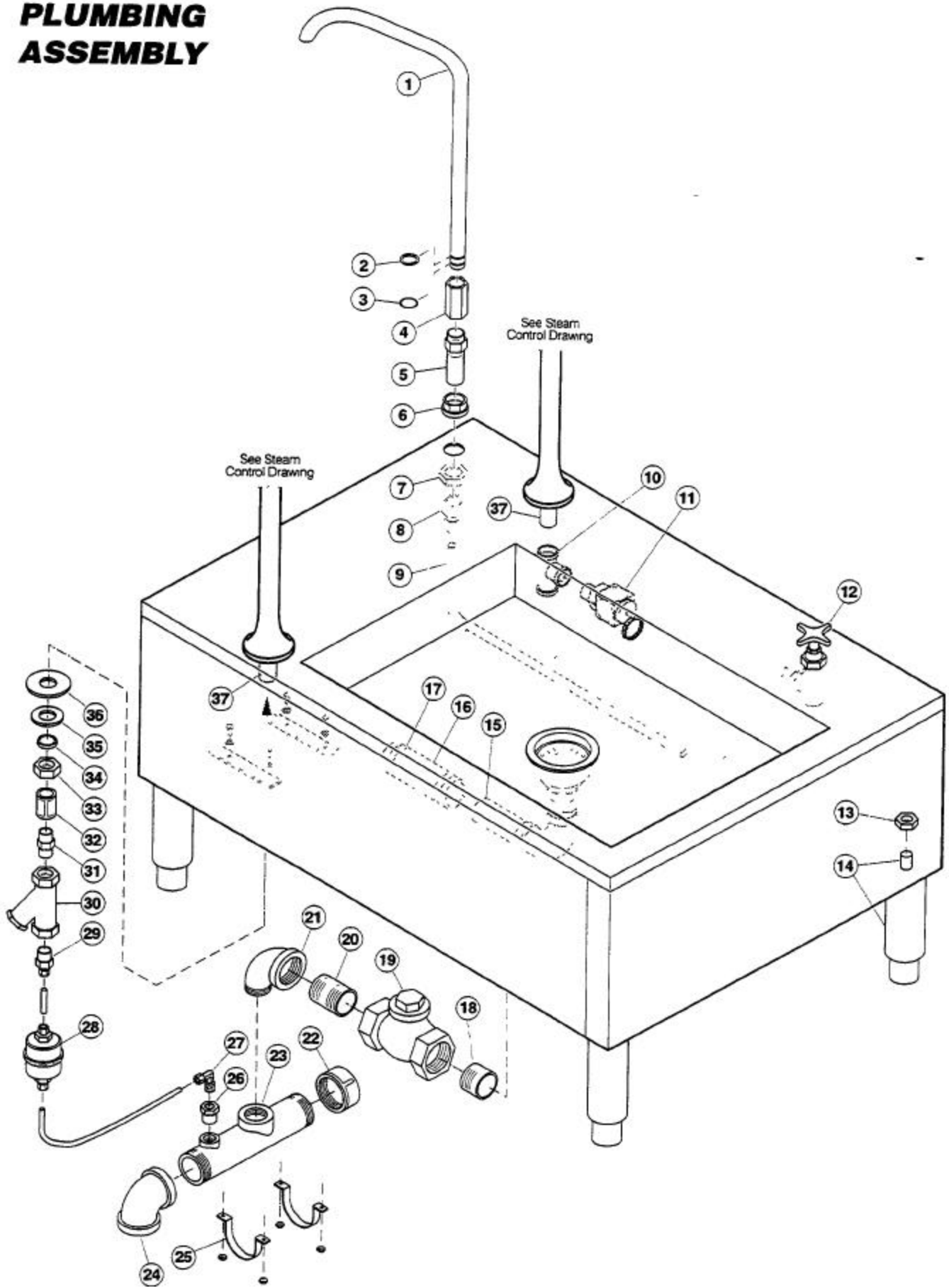

PLUMBING ASSEMBLY

ITEM NO.	PART NO.	DESCRIPTION	QTY.
1	KE50826	Faucet Spout	1
2	FA95022	Retaining Ring	1
3	FA00016	"0" Ring	1
4	KE51736	Long Faucet Nut	1
5	SD50097	Flanged Nut, 3/4" NTP Chrome Plated	1
6	KE51585	Faucet Spout Fitting	1
7	SD50098	Locknut, 3/4" NPT	1
8	FI00266	Coupling 1/2" NPT	1
9	SD50101	Copper Tube, 31 1/2" lg	
10	FI00169	Tee 1/2" NPT	1
11	KE51723	Pressure Relief Valve, 1/2" NPT	1
12	KE51899-1	Valve, cold water	1
13	FA95010	Jam Nut, #3/4-10	4
14	KE51340	Leg	4
15	SD50000	Strainer Assembly	1
16	SD50042	Radiator Hose, 4" lg	1
17	FI05131	Hose Clamp	2
18	SD50043	Nipple, threaded one end only	1
19	KE51367	Check Valve, 1 1/4" NPT	1
20	FI00670	Nipple	1
21	FI00136	90° Street Elbow, 1 1/4" NPT	1
22	FI00191	Cap, 1 1/2" NPT	1
23	KE00648	Drain Pipe Assembly	1
24	FI00044	90° Elbow, 1 1/2" NPT	1
25	FI05027	Pipe Strap	2
26	F105049	Male Connector	1
27	FI05077	Male Elbow	1
28	SD50027	Steam Trap	1
29	F105049	Male Connector	1
30	KE51249	Strainer, 1/2" NPT	1
31	FI00596	Nipple, 1/2" NPT	1
32	FI00266	Coupling, 1/2" NPT	1
33	KE52697	Lock Nut, 1/2" NPS	2
34	FA32500	Lockwasher	2
35	FA30502	Washer, satin coat	2
36	KE50467	Washer, Foot	2
37	KE50463	Service Pipe	2

MAINTENANCE

ALL SERVICE MUST BE PERFORMED BY A QUALIFIED SERVICE TECHNICIAN.

This kettle requires very little preventative maintenance other than daily cleaning. The pressure relief valve must be tested twice a year.

PRESSURE RELIEF VALVE TESTING PROCEDURE

WARNING

Kettle will be hot. Use gloves for protection.

The pressure relief valve must be checked at least twice a year as part of the normal maintenance performed.

1. Open steam valve and preheat kettle.
2. Stand to the side of the pressure relief valve discharge tube and pull ring three or four times to insure free movement. Hold valve open for two seconds each time, insuring there is rapid steam escape each time.
3. If valve appears to be sticking replace pressure relief valve. If foreign material is discharged, replace pressure relief valve and eliminate the source of contamination.

STEAM TRAP

Each kettle is equipped with a steam trap in the line of the kettle outlet to the drain, to remove line condensate that forms inside the steam jacket. A good steam trap at startup releases air and wet steam into the drain line for a few minutes, then holds the steam jacket. During cooking, the trap periodically releases accumulated condensate. If the kettle's cooking performance becomes inadequate after long use, replacement of the steam trap with a new one may restore kettle operation to peak efficiency.

WARRANTY

Our Company supports a worldwide network of Maintenance and Repair Centers. Contact your nearest Maintenance and Repair Centre for replacement parts, service, or information regarding the proper maintenance and repair of your cooking equipment.

In order to preserve the various agency safety certification (UL, NSF, ASME/Ntl Bd , etc), only factory-supplied replacement parts should be used. The use of other than factory supplied replacement parts will void warranty.

TROUBLESHOOTING GUIDE

This section contains information intended for use by Authorized Service Personnel only.

PROBLEM

A/ Kettle heats too slowly or does not come to a boil.

Probable Cause

1. Inadequate steam flow.

2. Steam trap not operating properly.

3. Food batches are not always the same.

Remedy

Check for correct steam using chart below.
 If kettle is connected to a steamer and powered by a generator the units should be operated sequentially (kettle boiling first, then start steamer).

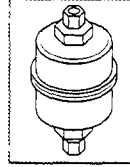

The trap should open periodically to dump condensate, then close. If it does not open or close it should be cleaned or replaced.

When checking make certain that the original state (i.e.fresh or frozen) and quantity of food product is the same.

PROBLEM

B/ The trunnion housing leaks steam.

Probable Cause

1. Trunnion "O" rings are worn.

Remedy

Replace "O" rings (see STEAM CONTROL ASSEMBLY drawing).

STEAM FLOW RATING OF STEAM GENERATORS

STEAM FLOW RATING REQUIREMENTS FOR KETTLES

Gas Input BTU/Hour	Steam Output Lbs./Hour	Boiler H.P.	Capacity Gal./Lit.	Fast Cooking	Medium Cooking	Stock Kettle
100,000	60	1.7				
160,000	95	28	5/17	11	9	6
200,000	125	36	10/42	22	18	11
250,000	150	44				
300,000	180	5.2	25/95	55	44	28
Electric			40/151	88	70	44
KW Input			60/227	132	105	66
18	60	1.7				
24	70	2.0				
27	90	2.6				
36	120	3.5				
48	150	4.4				

Electric:
 Above shows lbs per hour with 10-15 psig steam at the kettle. The use of higher steam pressures (20-25 psig) will reduce heat-up time 5-20%.

SPECIFICATION DRAWING

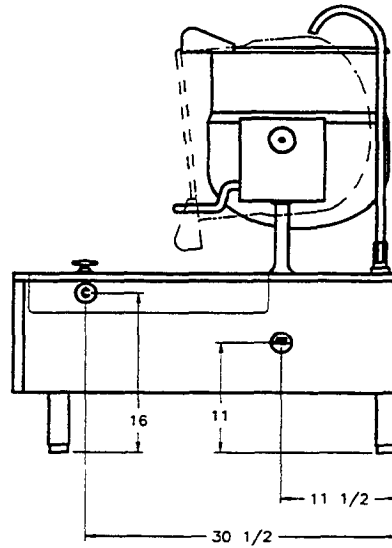
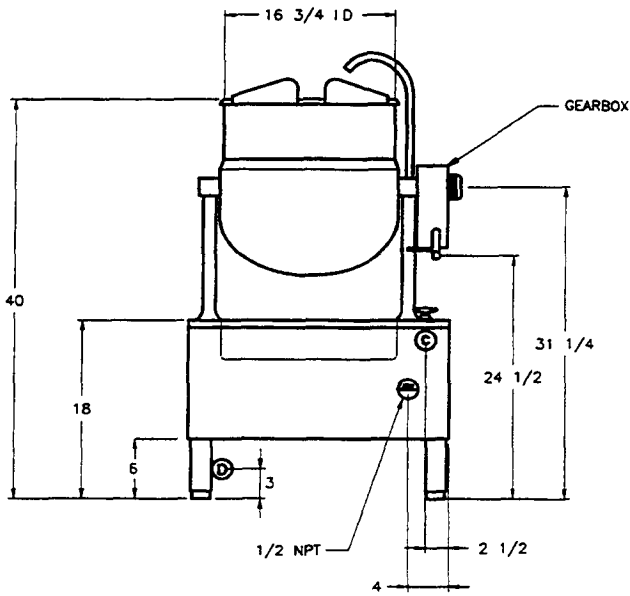
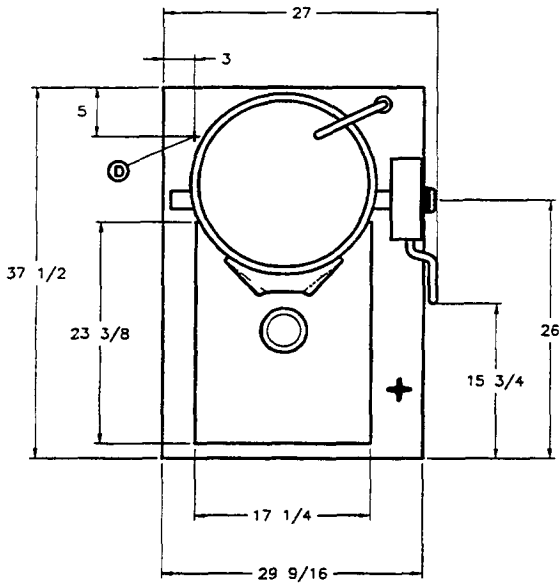

(S) DIRECT STEAM	(D) DRAINAGE	(C) COLD WATER	CONDENSATE RETURN	CLEARANCE
STEAM SUPPLY - FURNISH 1/2" IPS MINIMUM LINE - OPERATING PRESSURE 5 TO 45 PSI WITH A 50 PSI SAFETY VALVE	* 1/2" IPS	1/2" O.D. COPPER TUBE	CONNECTED TO DRAIN	RIGHT = 4" LEFT = 0 REAR = 0

Free Manuals Download Website

<http://myh66.com>

<http://usermanuals.us>

<http://www.somanuals.com>

<http://www.4manuals.cc>

<http://www.manual-lib.com>

<http://www.404manual.com>

<http://www.luxmanual.com>

<http://aubethermostatmanual.com>

Golf course search by state

<http://golfingnear.com>

Email search by domain

<http://emailbydomain.com>

Auto manuals search

<http://auto.somanuals.com>

TV manuals search

<http://tv.somanuals.com>