

ASSEMBLY, OPERATING INSTRUCTIONS AND PARTS LIST FOR CRAFTSMAN ACCRA-ARM 10 INCH RADIAL SAW



MODEL NUMBER 113.29003

The Model Number will be found on a plate attached to your saw, at the left side of the base. Always mention the Model Number in all correspondence regarding the CRAFTSMAN ACCRA-ARM RADIAL SAW or when ordering repair parts.

HOW TO ORDER REPAIR PARTS

All parts listed herein may be ordered through SEARS, ROEBUCK AND CO. or SIMPSONS-SEARS LIMITED. When ordering parts by mail from the mail order house which serves the territory in which you live, selling prices will be furnished on request or parts will be shipped at prevailing prices and you will be billed accordingly.

WHEN ORDERING REPAIR PARTS, ALWAYS GIVE THE FOLLOWING INFORMATION AS SHOWN IN THIS LIST:

1. The PART NUMBER
2. The PART NAME
3. The MODEL NUMBER 113.29003
4. The NAME of item—RADIAL SAW

COAST TO COAST NATION-WIDE SERVICE FROM SEARS FOR YOUR CRAFTSMAN ACCRA-ARM RADIAL SAW



SEARS, ROEBUCK AND CO. and SIMPSONS-SEARS LIMITED in Canada back up your investment with quick, expert mechanical service and genuine CRAFTSMAN replacement parts.

If and when you need repairs or service, call on us to protect your investment in this fine piece of equipment.

**SEARS, ROEBUCK AND CO. - U. S. A.
IN CANADA, SIMPSONS - SEARS LIMITED**

CRAFTSMAN ACCRA-ARM, 10-INCH RADIAL SAW, MODEL NO. 113.29003

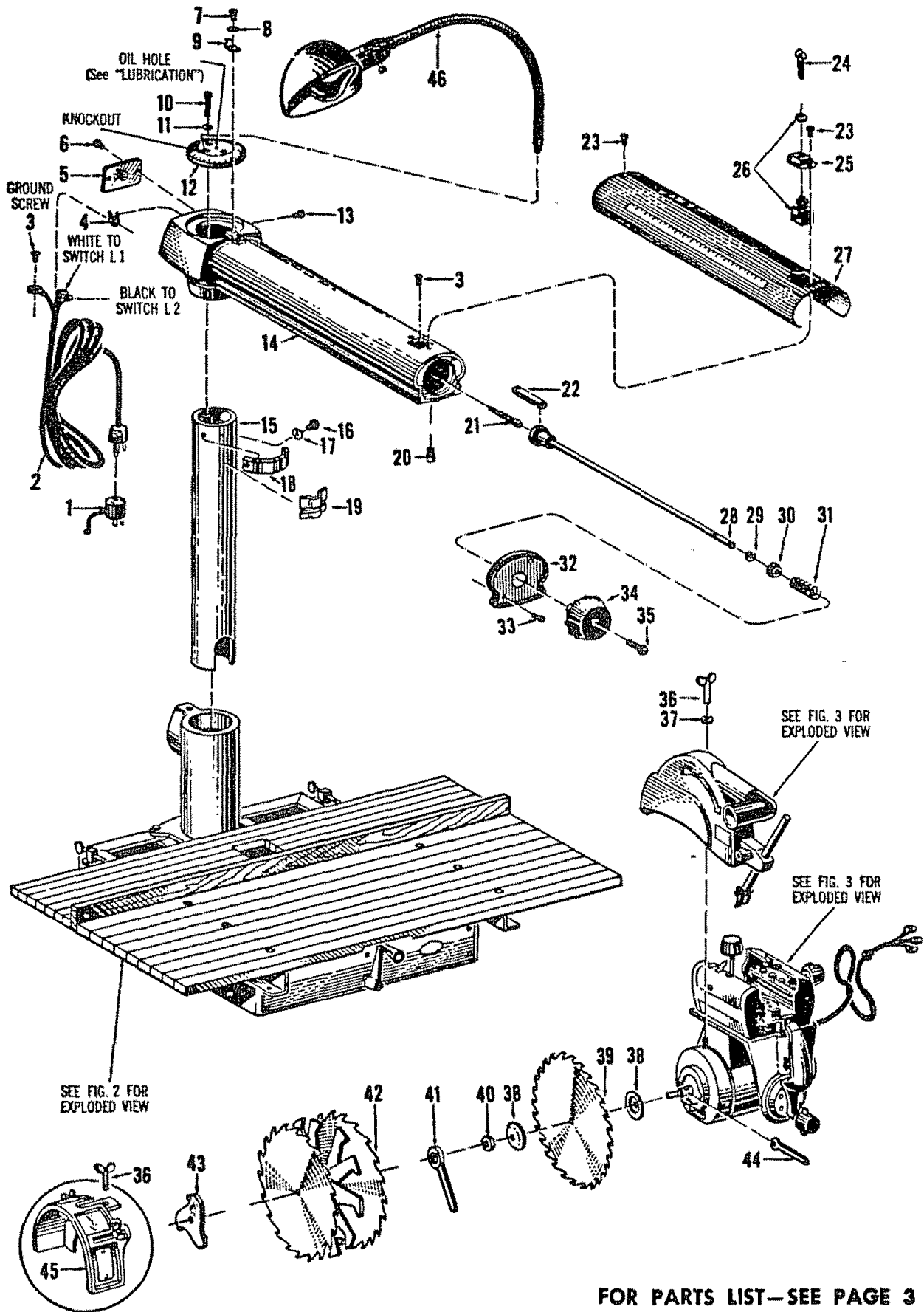

Figure 1

FOR PARTS LIST—SEE PAGE 3

CRAFTSMAN ACCRA-ARM, 10-INCH RADIAL SAW, MODEL NO. 113.29003

All parts illustrated in Figures 1 through 4 and listed under part numbers may be ordered through any Sears retail or mail order store. Order parts by mail from the mail order store which serves the territory in which you live. In several instances part numbers are listed for COMPLETE ASSEMBLIES. All parts are shipped prepaid within the limits of the continental United States.

WHEN ORDERING REPAIR PARTS ALWAYS GIVE THE FOLLOWING INFORMATION:

1. THE PART NUMBER.
2. THE PART NAME.
3. THE MODEL NUMBER 113.29003.
4. THE NAME OF ITEM—RADIAL SAW.

Do not use Ref. Numbers when ordering Repair Parts, always use Part Numbers.

FIGURE 1 PARTS LIST

Ref. No.	Part No.	Description	Ref. No.	Part No.	Description
1	30469	Adapter Plug	23	S-1266	*Pan Hd Mach Screw 8-32 x 5/16
2	30470	Cord with Plug	24	30483	Switch Key
3	S-1374	*Pan Hd Type 23 Screw 6-32 x 1/4	25	30484	Switch Cover
4	30472	Cord Clamp	26	30485	Switch
5	30473	Cover Plate Assembly	27	30704	Trim
6	S-602	*Pan Hd Mach Screw 10-32 x 3/8	28	30654	Arm Latch Shaft Assembly
7	S-1243	*Pan Hd Mach Screw 6-32 x 1/4	29	30655	Retaining Ring
8	S-1385	*Fiber Washer .140 x .250 x 1/32	30	30489	Spring Support Washer
9	30474	Indicator #1	31	30490	Arm Latch Spring
10	S-1336	*Fil Hd Mach Screw 1/4-28 x 1	32	30491	Trim Cap
11	S-1255	*Med Lock Washer 1/4 SAE	33	S-1265	*Pan Hd Mach Screw 10-32 x 3/4
12	30475	Radial Arm Cap	34	30492	Handle
13	S-1337	*Pan Hd Type B Sheet Metal Screw #8 x 3/4	35	S-1387	*Truss Hd Mach Screw 1/4-20 x 1-7/8 with Lockwasher
14	30476	Radial Arm	36	30493	Wing Nut
15	30671	Column Tube Assembly	37	S-1216	*Steel Washer 11/32 x 7/8 x 1/16
16	S-1393	*Hex Hd Cap Screw 3/8-16 x 3/4	38	30494	Collar
17	S-127	*Internal Shakeproof Lockwasher 12-20	39	9-3240	†10" Kromedge Chisel Tooth Saw Blade
18	30479	Arm Latch	40	30495	Shaft Nut
19	30661	Brake Shoe	41	3540	Arbor Wrench
20	S-1342	*Socket Hd Cap Screw 5/16-18 x 5/8	42	9-3247	†Dado Set
21	30662	Arm Lock Screw	43	9-3220	†Molding Cutter Head
22	30482	Arm Lock Pin	44	30496	Shaft Wrench
			45	9-29007	†Molding Cutter Guard
			46	9-2536	†Work Light

* Standard hardware item — may be purchased locally.

† Stock item — may be secured through the Hardware Departments of most Sears or Simpsons — Sears Retail Stores or Mail Order Houses.

NOTE: Shipping and handling charges for standard hardware items (identified by*) such as nuts, screws, washers, etc. make buying these items by mail uneconomical. To avoid shipping and handling charges, you may obtain most of these locally.

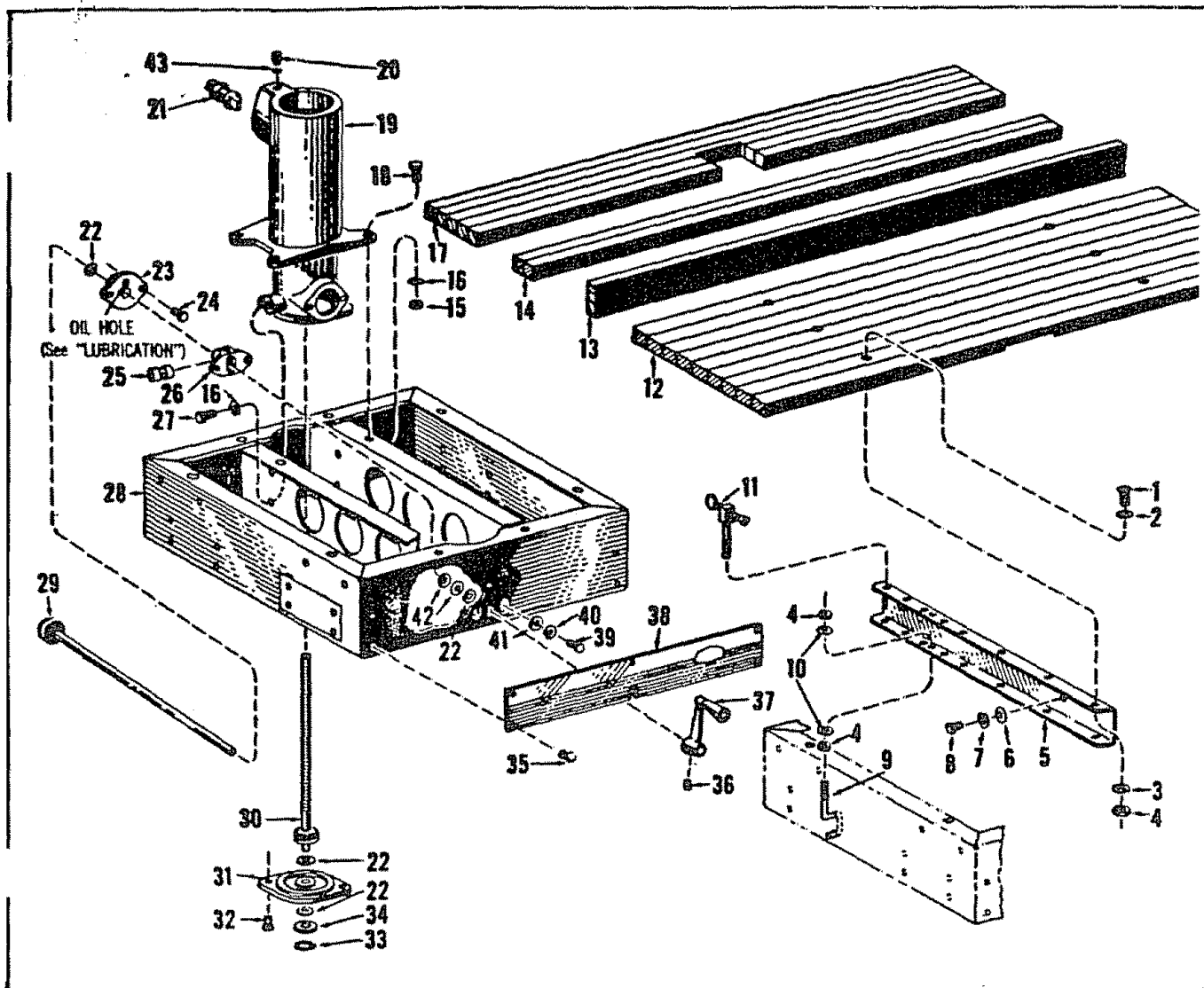

FIGURE 2 PARTS LIST

Ref. No.	Part No.	Description	Ref. No.	Part No.	Description
1	S-1346	*Rd Hd Mach Screw 1/4-20 x 7/8	22	30509	End Play Washer #8 (as req'd)
2	S-1284	*Steel Washer 17/64 x 5/8 x 1/32	23	30510	Elevation Shaft Bearing Bracket
3	S-1255	*Med Lock Washer 1/4 SAE	24	S-1353	*Hex Hd Mach Screw 1/4-20 x 3/4
4	S-1258	*Hex Nut 1/4-20 x 7/16 x 3/16	25	30511	Pivot Pin
5	30497	Channel	26	30512	Bearing Bracket
6	S-1216	*Steel Washer 11/32 x 7/8 x 1/16	27	S-1354	*Hex Hd Mach Screw 3/8-16 x 5/8
7	S-1343	*Med Lock Washer 5/16 SAE	28	30676	Base Assembly
8	S-1347	*Hex Hd Mach Screw 5/16-18 x 1/2	29	30508	Elevation Crank Shaft Assembly
9	30498	Adjusting Screw	30	30678	Elevation Shaft Assembly
10	S-1214	*Steel Washer 17/64 x 1/2 x 1/32	31	30515	Retaining Plate
11	30501	Table Clamp	32	S-1355	*Hex Hd Mach Screw 5/16-18 x 7/8
12	30499	Front Table	33	30516	Retaining Ring
13	30500	Fence	34	S-1356	*Steel Washer .515 x 7/7 x 1/32
14	30502	Table Spacer Board	35	30675	Stud Fastener
15	S-1348	*Hex Nut 3/8-16 x 9/16 x 21/64	36	S-1389	*Soc Set Screw 1/4-20 x 3/8
16	S-1349	Med Lock Washer 3/8 SAE	37	30518	Elevation Crank Assembly
17	30503	Rear Table	38	30517	Nameplate
18	S-1350	*Hex Hd Mach Screw 3/8-16 x 1-1/8	39	S-1359	*Hex Hd Mach Screw 10-32 x 3/8
19	30672	Column Support	40	S-1358	*Med Lock Washer #10 SAE
20	30673	Soc Set Screw	41	S-1375	*Steel Washer 13/64 x 7/16 x 1/16
21	30674	Column Tube Key	42	30604	Oil Sling Washer
			43	30718	Plug

* Standard hardware item — may be purchased locally.

CRAFTSMAN ACCRA-ARM, 10-INCH RADIAL SAW, MODEL NO. 113.29003

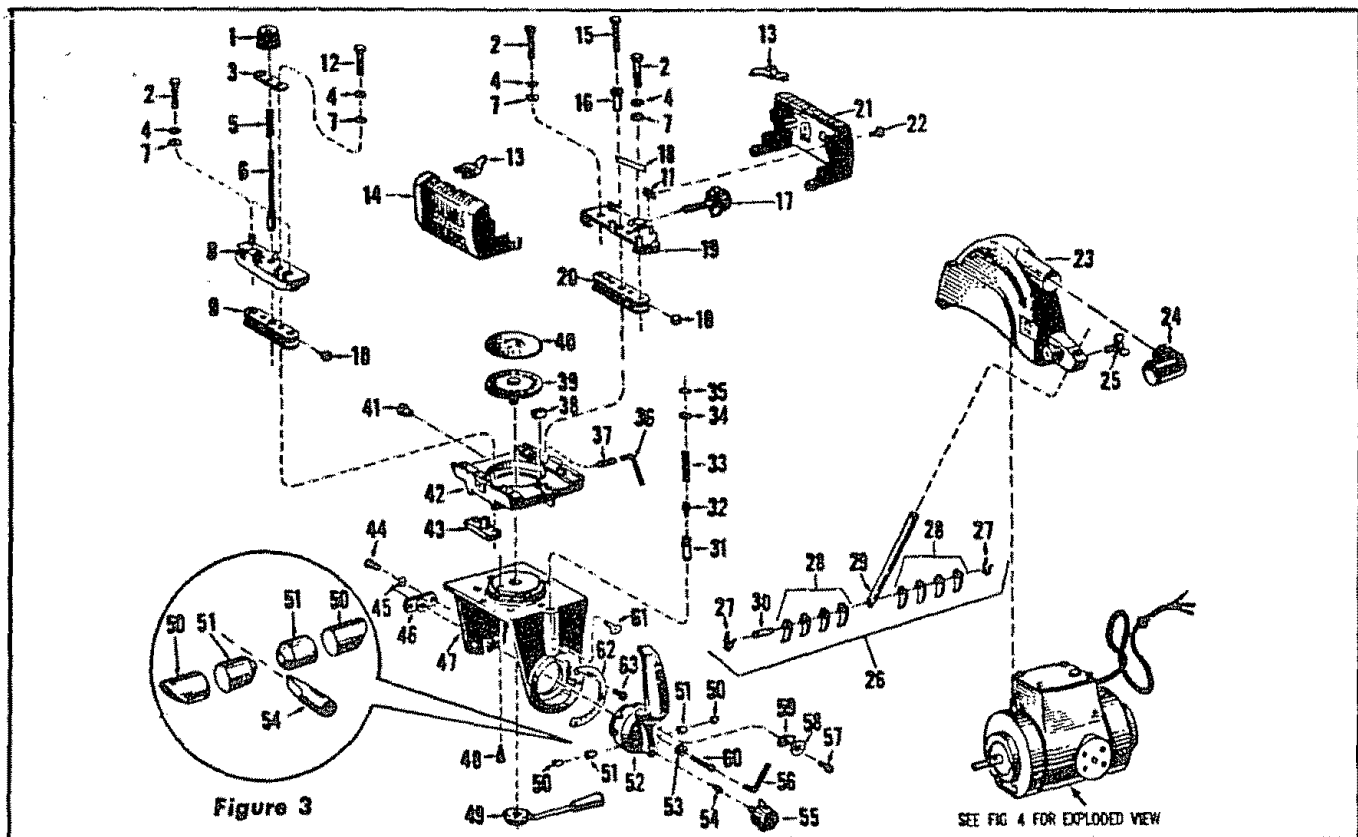

FIGURE 3 PARTS LIST

Ref. No.	Part No.	Description	Ref. No.	Part No.	Description
1	30519	Swivel Latch Pin Handle	32	30690	Latch Pin Handle Retainer
2	S-1361	*Hex Hd Mach Screw 5/16-18 x 1-1/2	33	30548	Latch Pin Spring
3	30679	Retaining Plate	34	30547	Disk
4	S-1343	*Med Lock Washer 5/16 SAE	35	30546	Retaining Ring #2
5	30521	Swivel Latch Spring	36	30505	Hex "L" Wrench 1/8 across flats
6	30657	Swivel Latch Pin	37	S-1390	*Soc Cup Point Set Screw 1/4-20 x 1
7	S-1392	*Steel Washer .328 x 3/4 x 1/16	38	30567	Bumper #2
8	30680	Ball Retainer	39	30566	Yoke Clamp Assembly
9	30524	Carriage Ball Race, left hand	40	30618	Dust Cover
10	30527	Ball	41	30565	Bumper
11	30682	Speed Nut	42	30691	Carriage
12	S-1363	*Hex Hd Mach Screw 5/16-18 x 2-1/4	43	30660	Latch Pin Housing
13	30683	Rip Scale Indicator	44	S-1366	*Hex Hd Mach Screw 1/4-20 x 7/16
14	30684	Carriage Cover, left hand	45	S-1255	*Med Lock Washer 1/4 SAE
15	30685	Eccentric Bushing Screw	46	30562	Motor Support Bearing
16	30686	Eccentric Bushing	47	30692	Yoke
17	30536	Carriage Lock Knob Assembly	48	30558	Lock Screw
18	30687	Carriage Lock Shoe	49	30557	Yoke Clamp Handle Assembly
19	30681	Ball Retainer, right hand	50	30665	Index Handle Brake Shoe
20	30615	Carriage Ball Race, right hand	51	30663	Expander
21	30688	Carriage Cover, right hand	52	30556	Bevel Index Handle
22	S-1394	*Pan Hd Mach Screw 8-32 x 3/8	53	30606	Index Handle Washer
23	30538	Saw Guard Assembly	54	30664	Pressure Pad
24	30539	Discharge Elbow	55	30551	Bevel Lock Knob Assembly
25	30540	Wing Screw	56	30552	Hex "L" Wrench 7/32 across flats
26	30541	Anti-Kick Back Pawl Assembly	57	S-1391	*Pan Hd Mach Screw 6-32 x 3/16
27	30542	X-Washer	58	S-1385	*Fiber Washer .140 x .250 x 1/32
28	30543	Anti-Kick Back Pawl	59	30559	Indicator #2
29	30544	Rod	60	S-1365	*Soc Hd Cap Screw 5/16-18 x 1-1/2
30	30545	Cross Pin	61	30693	Latch Pin Handle
31	30689	Bevel Latch Pin	62	30592	Bevel Scale
			63	S-1372	*#2 x 1/8 Type U Drive Screw

* Standard hardware item — may be purchased locally.

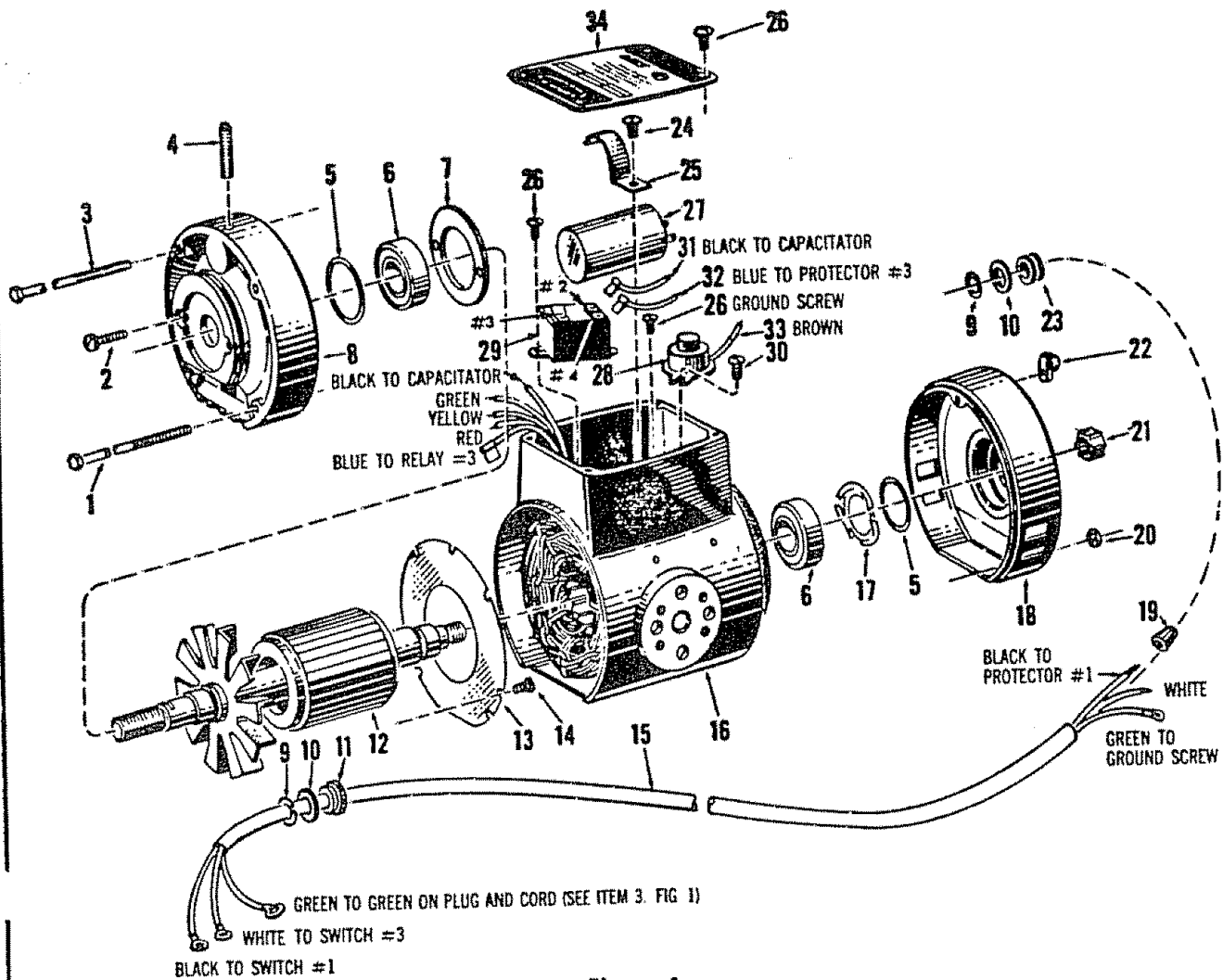

Figure 4

FIGURE 4 PARTS LIST

Ref. No.	Part No.	Description	Ref. No.	Part No.	Description
	30695	Assem. Motor (Less Guard Stud)	19	30573	Wire Connector
1	30696	Stator Screw	20	S-109	*Hex Nut 8-32 x 11/32 x 1/8
2	S-1367	*Pan Hd Mach Screw With Lockwasher	21	30582	Shaft Cap
3	30697	Stator Screw #2	22	30613	Cord Clamp #2
4	30570	Guard Stud	23	30583	Grommet
5	S-1371	*Steel Washer 1-9/16 x 1-27/32 x .010 (as req'd)	24	S-1285	*Pan Hd Mach Screw 8-32 x 3/8
6	30571	Bearing	25	30700	Capacitor Clamp
7	30572	Bearing Retainer Plate	26	S-1369	*Pan Hd Mach Screw 6-32 x 5/16
8	30719	End Shield #2	27	30586	Capacitor
9	30574	Hog Ring	28	30677	Protector
10	S-1368	*Fiber Washer .380 x 9/16 x 1/32	29	30588	Relay
11	30575	Insulating Bushing	30	S-1370	*Pan Hd Mach Screw 6-32 x 7/16
12	30698	Assembled Rotor	31	30701	Assembled Lead #1
13	30577	Baffle Plate	32	30590	Assembled Lead #2
14	S-1227	*Pan Hd Mach Screw 8-32 x 1/4	33	30619	#16 AWG U.L. Approved Wire 3-1/2"
15	30578	Cord	34	30702	Nameplate
16	30699	Assembled Stator	None	30670	Operating Instructions & Parts List for Craftsman Accra-Arm 10" Radial Saw, Model 113.29003
17	30580	Spring Washer			
18	30720	End Shield			

* Standard hardware item - may be purchased locally.

Instructions for Assembling and Operating Your Saw

NOTE: WHEN ORDERING REPAIR PARTS REFER TO PARTS LIST FOR CORRECT PART NUMBER.

1. Arbor Wrench
2. Shaft Wrench
3. Table Clamp
4. Adapter Plug
5. Yoke Clamp Handle
6. Radial Arm Indicator
7. Carriage Lock Knob
8. Rip Scale Indicator
9. Swivel Latch Pin Knob
10. Latch Pin Handle
11. Switch Key
12. Arm Latch Handle
13. Bevel Index Handle
14. Discharge Elbow
15. Anti Kick Back Pawl Assembly
16. Bevel Lock Knob
17. Bevel Index Scale and Indicator
18. Elevation Crank
19. Hex "L" Wrenches

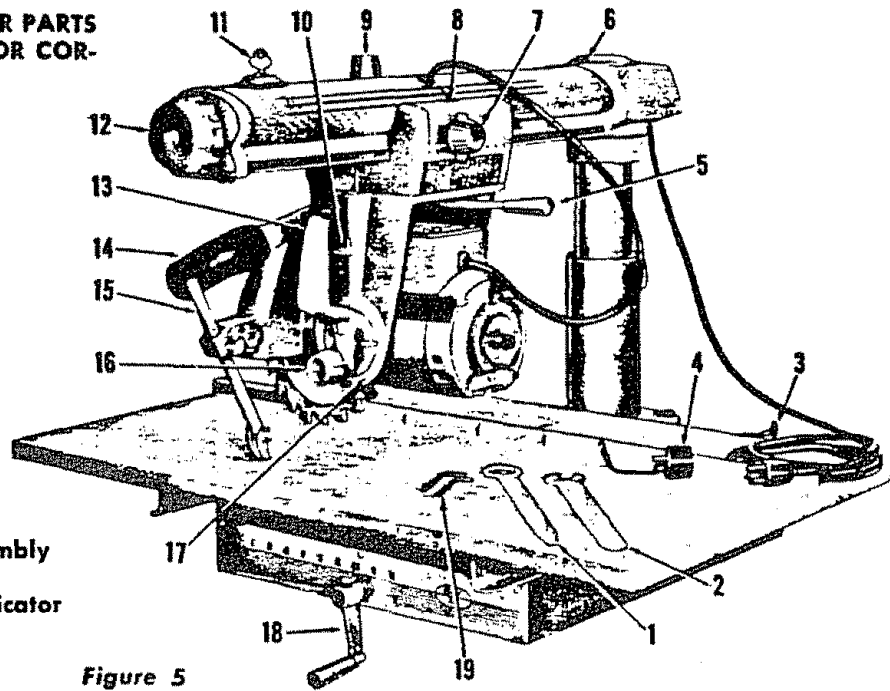

Figure 5

ASSEMBLING-ADJUSTING

CONNECTING THE MOTOR TO THE POWER SUPPLY Motor Specifications

115/230 volt, 10/5 amps, 3450 RPM, 60 cycle, alternating current (A.C. only) single phase, non-reversible. Rotation: clockwise viewing saw blade end of motor shaft. The motor as shipped is connected for 115 volts. For 115 volt operation see Figures 6 and 7 for connecting plug and cord from saw into 115 volt receptacle.

Safety Precaution

The saw motor is equipped with a manual reset, thermal overload protector. If during operation this protector opens the line, immediately turn the switch "Off". The protector can be closed again after the motor has cooled by firmly pushing the red button on the capacitor cover until the protector snaps into the running position. Do not tap or strike the reset button. This protector is not intended to take the place of a fuse as the protector will not provide protection against overloads or short circuits in the lines leading to the motor. The motor should not be operated on a load which causes the protector to open the line frequently. For circuit protection use a "Fustat" or "Fusetron" fuse —15 ampere fuse for 115 volt operation and 7½ ampere fuse for 230 volt operation.

For 230 volt operation, see connecting instructions on motor nameplate. Also see the "Warning Label" on the rear of the saw base.

"IMPORTANT" The following wire sizes are recommended for connecting the motor to a power source for **TROUBLE FREE OPERATION.**

Length of Conductor	Wire Size Required (American Wire Gauge No.)
115 Volt Lines	
50 feet or less	No. 12
100 feet or less	No. 10
100 feet to 150 feet	No. 8
150 feet to 200 feet	No. 6
200 feet to 400 feet	No. 4
230 Volt Lines	
50 feet or less	No. 14
100 feet or less	No. 12
100 feet to 150 feet	No. 10
150 feet to 200 feet	No. 8
200 feet to 400 feet	No. 6

For circuits of greater length the wire size must be increased proportionally.

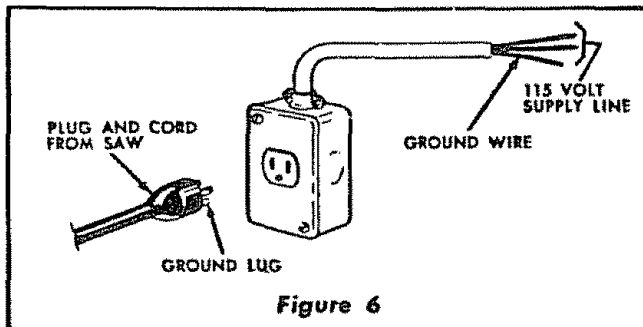

Figure 6

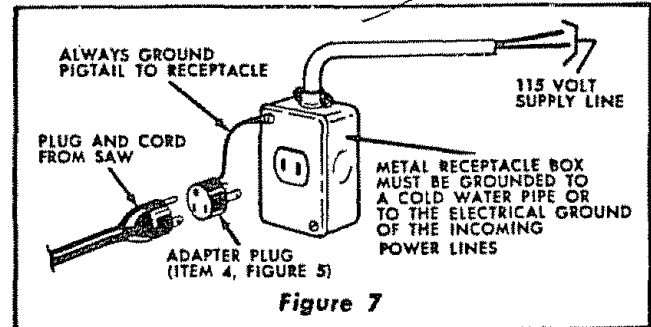

Figure 7

MOUNTING THE SAW TO A WORK BENCH

The saw should be placed on a suitable sturdy work bench and positioned so that the elevation crank (figure 8) is free to rotate. The base of the saw must be mounted to a flat surface on the work bench to prevent distortion of the saw base. The nuts, screws, and washers which attach the wooden shipping skids to the saw base may be used to secure the saw base to the work bench. Check that saw is level or sloped slightly to the rear so that carriage when unclamped, does not run freely to the front end of the radial arm.

INSTALLATION OF THE TABLE AND FENCE

1. Turn elevation crank to raise motor clear of shipping brackets.
2. Remove shipping brackets from base.
3. Place front table on channels with notch in table forward and down as shown in Figure 8.
4. Align holes in front table with three forward mounting holes in channels. See Figure 8.
5. Assemble six machine screws and washers through six holes as shown.
6. Attach six lockwashers and nuts. Before tightening nuts securely push table evenly toward rear of saw. Tighten nuts.
7. Lay fence in vertical position behind front table.
8. Lay table spacer board behind fence.
9. Lay rear table with cut-out section forward behind table spacer board.
10. Install table clamps as shown and tighten securely against edge of rear table.

ADJUSTING THE TABLE PARALLEL TO THE RADIAL ARM

1. Remove saw guard with holding washer and wing nut.
2. Remove shaft nut and one loose collar on motor shaft. See Figure 11.
3. Insert arbor wrench between collars on motor shaft. See Figure 9. Tighten shaft nut by hand.
4. Tighten radial arm handle (Item 12, figure 5).
5. Loosen carriage lock knob (Item 7, figure 5) and turn elevation crank until end of arbor wrench just touches the table top thus permitting the wrench to be swung back and forth. See Position 1, Figure 9. Mark this spot and Positions 2, 3 and 4 with a pencil.

NOTE

Do not turn the elevation crank throughout the remainder of this procedure as the radial arm must remain at the same height above the table while checking at Positions 1, 2, 3 and 4 of Figure 9.

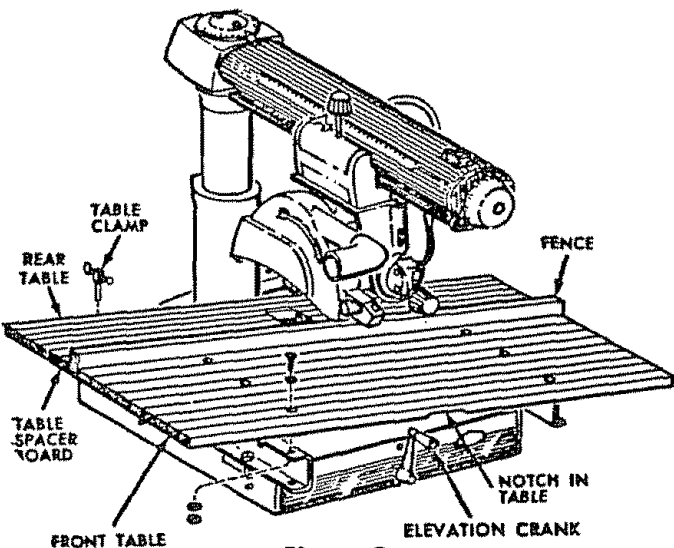

Figure 8

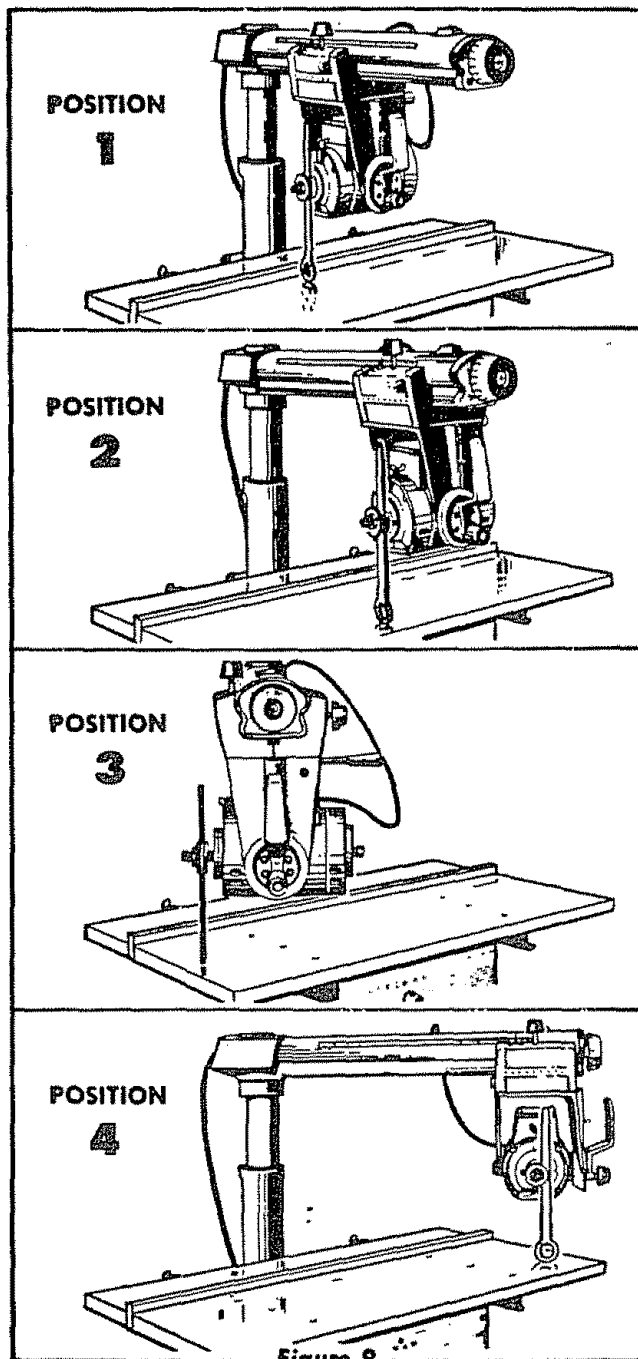

Figure 9

6. Pull motor to Position 2. Wrench when moved back and forth should just contact table top as in step 4.
 7. Turn arm latch handle (Item 12, figure 5) counterclockwise and pull out. Move arm to Position 3 of Figure 9. Tighten radial arm handle and repeat procedure of step 6.
 8. Move radial arm to Position 4 of Figure 9, tighten radial arm handle and repeat above procedure.
- If contact between the wrench and the table top is not the same at all four positions the table can be leveled as follows: (See Figure 10).

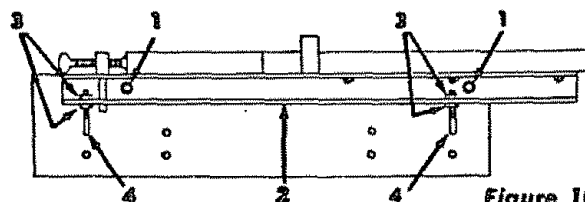
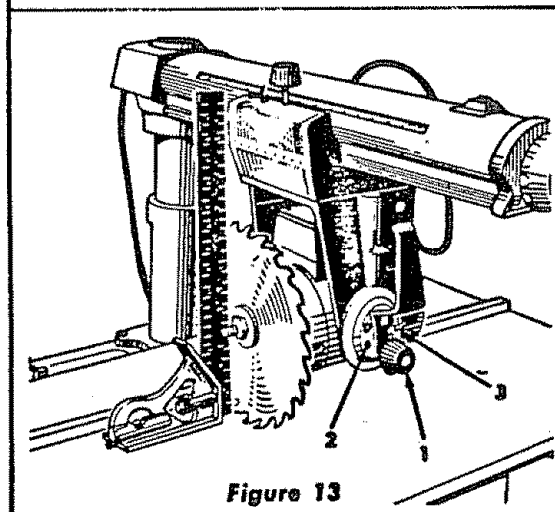
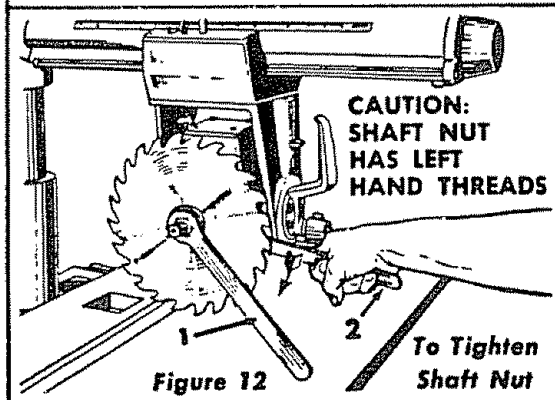
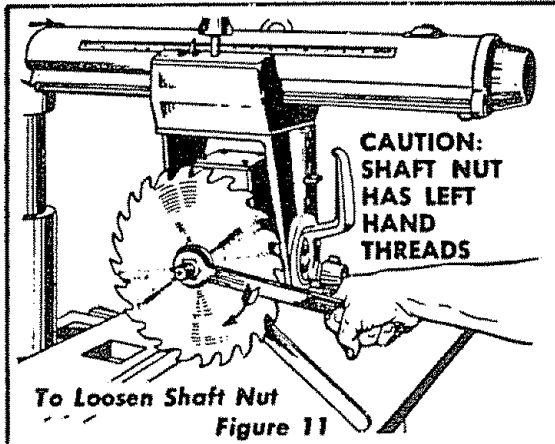

Figure 10

1. Loosen the clamping screws (Item 1) on both channels (Item 2).
2. Adjust nuts (Item 3) by alternating loosening and tightening so that the channels are moved up or down on the adjusting screws (Item 4) in the desired direction.
3. When channels are properly adjusted the arbor wrench will just contact the table top when swung back and forth at Positions 1, 2, 3, and 4 of Figure 9. Tighten clamping screws (Item 1). Recheck the four positions to insure that no change has occurred.

ATTACHING THE SAW BLADE

1. Remove shaft nut and one loose collar.
2. Place saw blade on motor shaft taking care that saw blade teeth are in same direction as shown in Figure 11.
3. Replace other loose collar and shaft nut. Smooth face of collar must be away from saw blade.
4. Use arbor wrench (Item 1, figure 12) on motor shaft nut and shaft wrench (Item 2, figure 12) on slot in motor shaft to tighten shaft nut.



SQUARING THE SAW BLADE TO THE TABLE TOP

1. Place edge of combination square or accurate steel square on table top and position as shown in Figure 13. Square must be held firmly against table top.
2. When blade is square to the table no light will be visible between square and face of saw blade. Do not allow square to rest on saw teeth. If light is visible between steel square and face of saw blade adjust as follows:
 - a. Loosen bevel lock knob (Item 1, figure 13). Use 7/32 hex "L" wrench and slightly loosen four socket head screws (Item 2, figure 13).
 - b. Hold motor shaft at one end and tilt motor in proper direction until saw blade is square to table top. See Step 2 above.
 - c. Retighten socket head screws (Item 2, figure 13) and bevel lock knob (Item 1, figure 13).
 - d. Recheck blade squareness to table top since tightening of screws may have shifted motor.
 - e. Indicator (Item 3, figure 13) should read 0° on bevel index scale. If not, loosen screw and adjust indicator. Retighten screw.

CHECKING COLUMN TUBE KEY

If excessive radial arm movement is noticed even though the arm is locked in position, check the fit of the column tube key (Item 2, figure 14) and the keyway in the column tube.

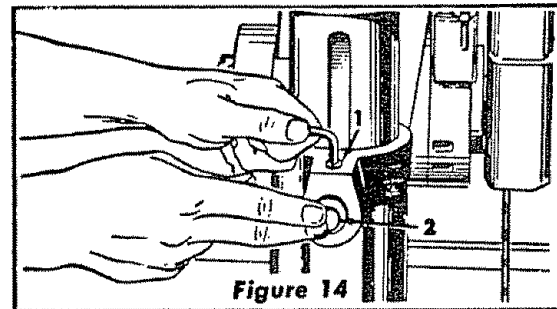

1. Adjust by loosening the socket set screw (Item 1, figure 14), using the 7/16 hex "L" wrench.
2. Press vigorously against the rear of the column tube key (Item 2, figure 14) or C-clamp the key while slightly rocking the radial arm back and forth. This causes the key to seat properly in the keyway.
3. Tighten the set screw (Item 1, figure 14) securely while maintaining pressure on the key.

SQUARING THE CROSS CUT TRAVEL TO THE FENCE

1. Set radial arm at 0° index position and tighten arm latch handle. See Page 11 "Angular Movement and Locking of the Radial Arm" for the most positive and accurate settings at an index position.

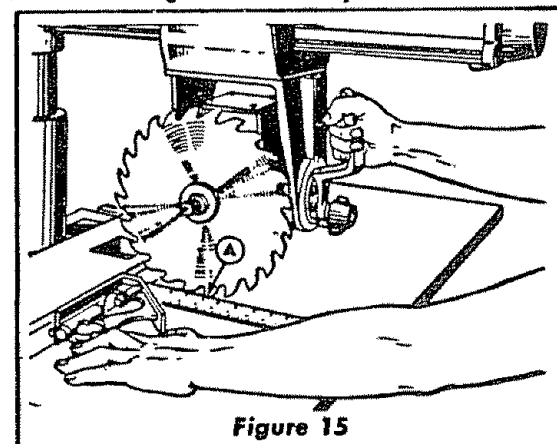

2. Lay combination square or accurate steel square against fence as shown in Figure 15 and position until it just contacts a blade tooth (See A, figure 15). Mark this tooth.
3. When the carriage is moved back and forth on radial arm saw tooth "A" should just touch square at all positions.

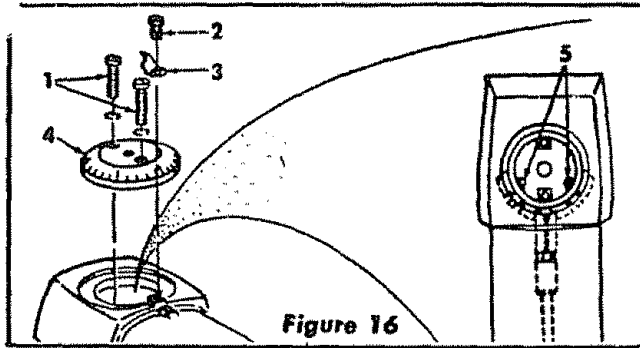

Figure 16

If saw tooth "A" does not touch square as in step 3, adjust as follows:

- a. If saw tooth "A" (Figure 15) moves away from the square when moving the blade from the rear to the front of the table, completely loosen the three screws holding the table to the channel on the lefthand side of the table and slightly loosen those on the right side of the table. Slightly tighten the left table clamp (Item 1, Position 4, Figure 9).
- b. Tighten all table screws first, then both table clamps. Recheck blade squareness again.
- c. Reverse this procedure if tooth "A" moves into the square when moving the saw blade from the rear to the front of the table.

In some cases, the above adjustment may not be sufficient. If this is the case, adjust as follows:

1. Remove three screws (Item 1 and 2, figure 16), indicator (Item 3) and radial arm cap (Item 4).
2. Turn arm latch handle 1/2 turn counterclockwise to release brake. Do not pull out.
3. Slightly loosen (do not remove) two hex head screws (Item 5) inside of column tube.
4. Move radial arm in proper direction to make saw tooth "A" (Figure 15) follow edge of square when checking.
5. Retighten hex head screws (Item 5, figure 16) and arm latch handle.
6. Recheck blade tooth "A" travel with square.
7. After blade is square to fence reassemble radial arm cap and indicator using screws (Item 1 and 2, figure 16). Set indicator at 0°.

PRELIMINARY CROSS-CUT AT THE 0° POSITION

1. Attach saw guard (Item 1, figure 17) washer (Item 2) and wing nut (Item 3) to motor and motor stud (Item 4).
2. Pull motor forward of fence so that blade is free to rotate.
3. Lower radial arm until saw blade just clears table top.
4. Tighten carriage lock knob (Item 5, figure 17).

CAUTION

Before cutting always be sure that the arm latch handle is locked fully clockwise. (Item 8, figure 17.)

5. Plug in power cord to receptacle.
6. Insert switch key (Item 6, figure 17) and turn "On".
7. Lower radial arm until blade cuts into table top 1/32". THIS IS ALL THAT IS NECESSARY.

To cut a blade clearance groove in the table and fence hold the bevel index handle (Item 7, figure 17) with the left hand and loosen the carriage lock knob (Item 5, figure 17) with the right hand. Slowly pull the motor with the left hand out to the extreme end of travel and then push the motor back through the fence to the extreme rear position. Turn the key switch "Off".

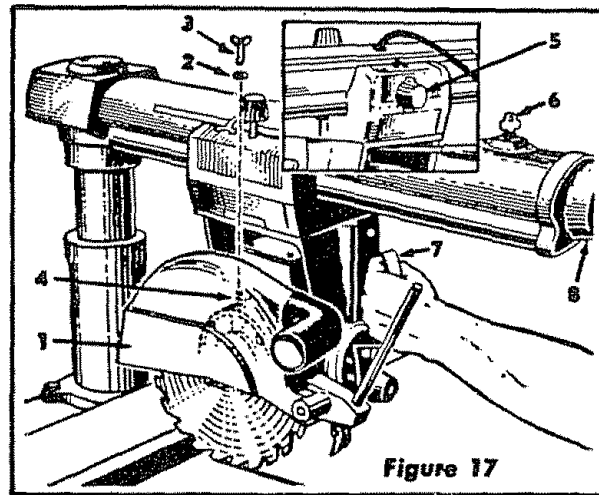

Figure 17

CHECKING THE SAW BLADE FOR HEEL (LEFT AND RIGHT)

Using a scrap piece of one-inch lumber approximately six inches wide, lay it on the table against the fence on the left side of the blade. Position the board to permit a three-inch piece to be cut from the right end holding the board firmly against the fence with the left hand. Turn the key switch "On" and commence the cut by pulling the saw forward through the board until the front half of the saw blade clears as shown in View A. Turn the switch "Off" and allow the saw blade to come to a complete stop while the rear portion of the blade is still in contact with the wood. Marks on the face of the board indicate left heeling. Check face of cut board. See View A. To check for right heeling repeat the same cut from the right side of the blade. Check for heel marks. See View B.

NOTE

The piece of wood must be held firmly against the fence and not permitted to move while the saw blade is coming to a stop.

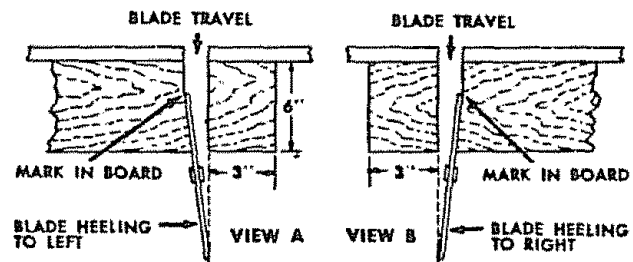

Exaggerated View of Heeling Condition

To correct for heeling (left or right) proceed as follows:

1. Remove left hand carriage cover (Item 1, figure 18).

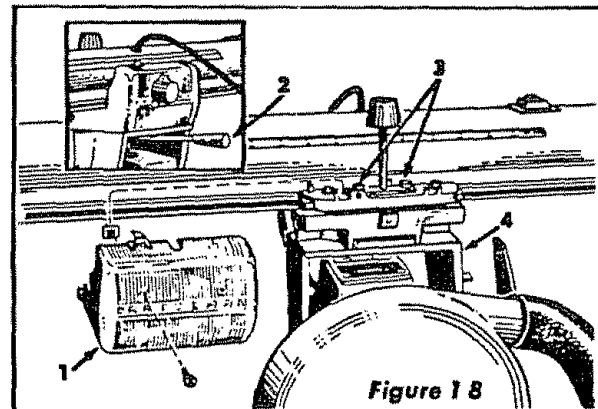

Figure 18

2. Loosen yoke clamp handle (Item 2, figure 18) by pulling the handle horizontally toward the front of the saw.
3. Slightly loosen the two hex head machine screws (Item 3, figure 18).
4. Rotate the yoke (Item 4, figure 18) very slightly opposite to the direction of heel. (For left heel, rotate yoke clockwise; for right heel rotate yoke counterclockwise.)

5. Retighten the two hex head machine screws (Item 3, figure 18) and relock the yoke by pushing the yoke clamp handle toward the rear of the saw.
6. Recheck for left and right heel as before.
7. When the heeling condition is corrected the face of the board will show no marks when cut from either side of the blade.
8. Replace carriage cover.

OPERATING CONTROLS

1. Arbor Wrench
2. Shaft Wrench
3. Table Clamp
4. Adapter Plug (Except in Canada)
5. Yoke Clamp Handle
6. Radial Arm Indicator
7. Carriage Lock Knob
8. Rip Scale Indicator
9. Swivel Latch Pin Knob
10. Latch Pin Handle
11. Switch Key
12. Arm Latch Handle
13. Bevel Index Handle
14. Discharge Elbow
15. Anti Kick Back Pawl Assembly
16. Bevel Lock Knob
17. Bevel Index Scale and Indicator
18. Elevation Crank
19. Hex "L" Wrenches

NOTE: WHEN ORDERING REPAIR PARTS REFER TO PARTS LIST FOR CORRECT PART NUMBER.

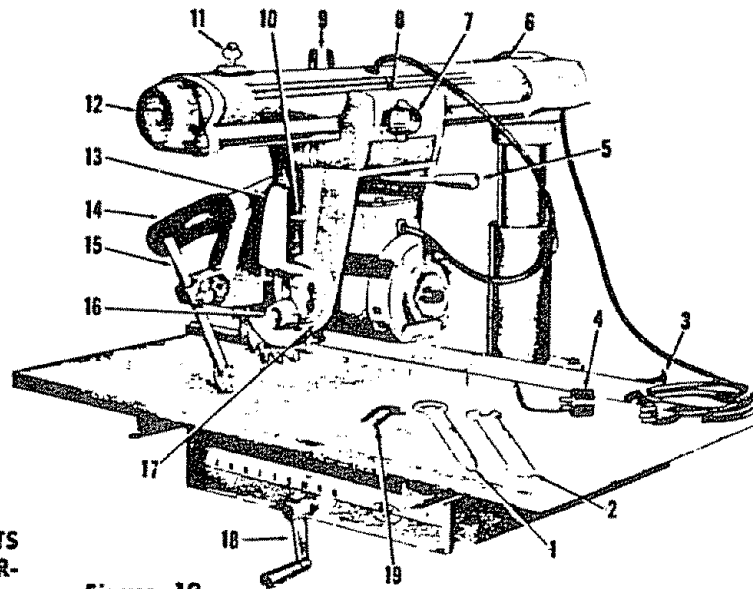

Figure 19

RAISING AND LOWERING THE RADIAL ARM is accomplished by the elevation crank (Item 18, figure 19). One complete turn of this handle will raise or lower the radial arm $\frac{1}{8}$ ".

LOCKING THE CARRIAGE TO THE RADIAL ARM is accomplished by the carriage lock knob (Item 7, figure 19). Turn the knob clockwise to lock; counterclockwise to unlock.

ANGULAR MOVEMENT AND LOCKING OF THE RADIAL ARM are controlled by the arm latch handle (Item 12, figure 19). The radial arm can be rotated 360° and locked in any position. The arm is unlocked from any position by a slight counterclockwise rotation of the arm latch handle and is locked in any position by rotating the arm latch handle clockwise until tight. The radial arm has positive stops at 0° and 45° left and right, and is released from these index positions by unlocking and pulling out the arm latch handle (Item 12, figure 19). Due to positive arm locking at the index positions, the arm latch handle may be difficult to pull out. A few turns to the left will release it.

For most positive and accurate settings at the index positions, the following is recommended:

1. If the radial arm is already indexed, unlock and pull out the arm latch handle and move the radial arm off of the index position. Release the arm latch handle.
2. Before moving the radial arm to the desired index position, turn the arm latch handle (Item 12, figure 19) just $\frac{1}{4}$ turn counterclockwise from the locked position.
3. Move the radial arm into the index position (do not bump or jar) and hit the face of the arm latch handle solidly with the palm of the hand.
4. Lock the radial arm by turning the arm latch handle fully clockwise.

CAUTION: When moving the radial arm in any direction beyond 45° left or right, always pull out

the arm latch handle (at end of radial arm) to prevent damaging the arm lock pin. If damage occurs, the radial arm will not index properly at 0° and 45° left or right.

MOVEMENT AND POSITION OF THE MOTOR IN THE YOKE are controlled by the latch pin handle (Item 10, figure 19) and bevel lock knob (Item 16, figure 19). The bevel scale indicates the angular position of the motor with respect to the horizontal from 0° to 90° in either vertical position. The latch pin handle automatically indexes the motor at 0°, 45°, and 90° up and down. Lift to release. At any other position the latch pin handle is not engaged. The bevel lock knob locks the motor to the yoke when the motor is in any position. Locking is clockwise; unlocking is counterclockwise.

MOVEMENT AND POSITION OF THE YOKE are controlled by the swivel latch pin knob (Item 9, figure 19) and the yoke clamp handle (Item 5, figure 19). The swivel latch pin automatically indexes the yoke at each 90° position and two 45° positions. Lift to release. The yoke clamp handle locks the yoke to the carriage in any position. Pull to release. Push to tighten. When "In Ripping" it may be desirable to have more free table in front of the saw blade than is obtainable when the radial arm is at the 0° position. With the blade in the normal cross-cut position index the radial arm to 45° left and lock it. Then loosen the yoke clamp handle and index the yoke 45° clockwise. Reclamp the yoke clamp handle. The added free table space is now to the right of the blade and ripping should be done from the right side of the table. The reverse is also true for "Out Ripping" by indexing the radial arm 45° right and indexing the yoke 45° counterclockwise. The added table space is now to the left of the blade and ripping should be done from the left side of the table.

CAUTION: Under these two conditions the In-Rip and Out-Rip scales cannot be used.

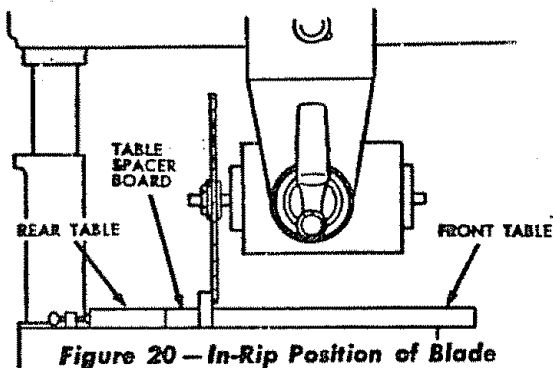

Figure 20 — In-Rip Position of Blade

ADJUSTMENT OF RIP SCALE INDICATORS

When the fence is in its normal position (next to the front table), index the yoke 90° from the cross-cut position so that the blade is between the motor and the fence. Lock the yoke.

Move the motor along the radial arm until the blade, when spun by hand, just touches the front face of the fence (See Figure 20). The indicator (Item 8, figure 19) on the "In-Rip" scale should now read 0. If not, shift the position of the indicator to read 0.

The same indicator should also read correctly on the "Out-Rip" scale when the blade is in the out-rip position. This indicator should be reset with any blade change.

The "Out-Rip" scale on the left side of the radial arm is only used when the fence is in its extreme rear position against the table clamps and the blade is in the out-rip position. The same method of adjustment is used for this scale indicator except that the blade is positioned as shown so that 9" is measured between the fence and the nearest blade tooth. (See Figure 21).

The indicator should then be adjusted to read 9" on the "Out-Rip" scale on the left side of the radial arm.

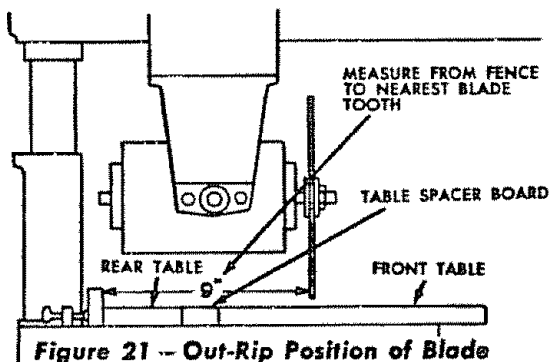

Figure 21 — Out-Rip Position of Blade

ADJUSTMENTS TO COMPENSATE FOR WEAR

Even though the finest materials and precision workmanship have been used to minimize wear it is reasonable to expect some wear. Adjustments have been built into your Craftsman saw to reduce or eliminate this wear.

COLUMN TUBE KEY ADJUSTMENT

If excessive radial arm movement is noticed even though the arm is locked in position, check the fit of the column tube key (Item 2, figure 22) and the keyway in the column tube.

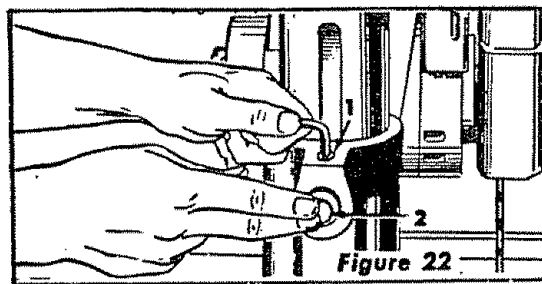

Figure 22

1. Adjust by loosening the socket set screw (Item 1, figure 22), using the 7/16 hex "L" wrench.
2. Press vigorously against the rear of the column tube key (Item 2, figure 14) or C-clamp the key while slightly rocking the radial arm back and forth. This causes the key to seat properly in the keyway.
3. Tighten the set screw (Item 1, figure 22) securely while maintaining pressure on the key.

YOKE CLAMP HANDLE ADJUSTMENT

The normal locking position of the yoke clamp handle (Item 1, View A, figure 23) is midway between the two sides of the yoke.

When the handle strikes the yoke before locking, the handle may be adjusted as follows:

1. Remove saw guard and blade.
2. Set yoke clamp handle to Position A, Figure 23. (Midway.)
3. Remove lock screw (Item 3).
4. With off-set screw driver turn slotted end of the yoke clamp (Item 2) counterclockwise until a slight snugness of the yoke clamp handle is felt at Position A, Figure 23.

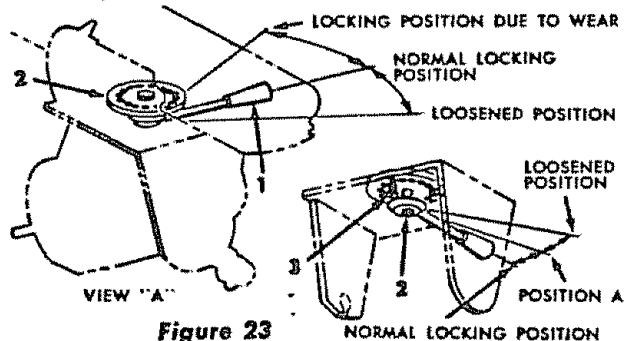

Figure 23

5. To replace lock screw align holes in yoke clamp with hole in yoke by a slight adjustment of yoke clamp using off-set screw driver. Insert lock screw and tighten.

CARRIAGE

To test for looseness in the carriage, firmly grasp the carriage (Item 1, figure 24) at the level of the ball races and apply a firm rocking motion.

Noticeable looseness may be adjusted as follows:

1. Remove saw guard and blade.
2. Place block of wood on table under motor and turn elevation crank until weight of motor just rests on block.
3. Remove carriage lock knob assembly (Item 2, figure 24) and carriage cover (Item 3, figure 24).
4. Loosen 3 hex head machine screws (Item 1, figure 25), eccentric hold-down screw (Item 2, figure 25) and two adjusting set screws in the holes on the side of the carriage (Items 5, figure 25). Use 1/8 hex "L" wrench on set screws.
5. Rotate eccentric bushing (Item 3, figure 25) clockwise to obtain snug fit. The ball retainer (Item 4, figure 25) should be guided at both ends by hand to prevent cocking.

6. Retighten all hex head screws and eccentric hold-down screw. (Do not allow eccentric bushing to rotate when tightening.)
7. Correct adjustment exists when there is no play between the carriage and radial arm, and yet the carriage moves freely. After adjustment is completed snugly tighten the two adjusting set screws. *Caution: Do not overtighten.*
8. Replace carriage cover and lock knob assembly.

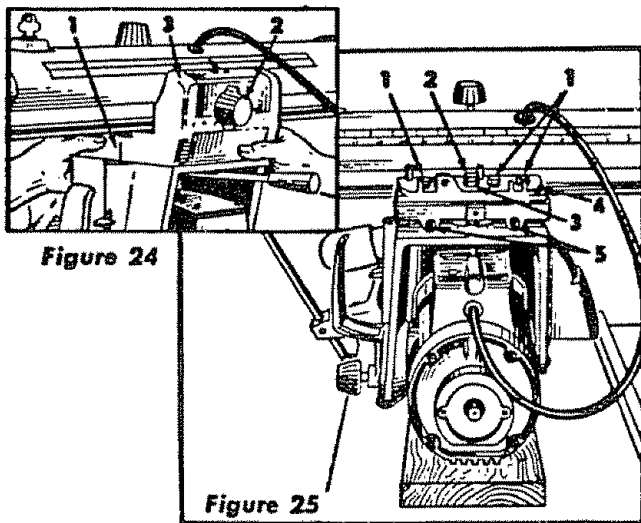

PROPER OPERATING PROCEDURES

DRESS PROPERLY — Operation of the saw is simple, safe and easy—when properly done. Always be alert. Do not wear a tie or other loose articles. Keep long sleeves down with cuffs fastened or wear short sleeves. **NEVER STOP BEING CAREFUL.** One moment of inattention can cost you a painful injury.

AVOID AWKWARD HAND POSITIONS — Do not get hands into a position in which a sudden slip can cause them to move into the saw blade. **NEVER OPERATE THE SAW WITH THE ARMS IN A CROSSED POSITION.** Never hold work on right side of blade with left hand while pulling saw with the right hand. Do not attempt free-hand cross-cutting. Use a push stick when hand gets too close to the blade in a ripping position.

NEVER TWIST WORK — Twisting work will bind blade and cause a kickback.

Safety Precaution

The motor is shipped with a shaft cap (Item 21, figure 4) threaded onto the stub end of the motor shaft. When this shaft end of the motor is not being used, this cap should always be in place.

LUBRICATION

Your saw is a fine machine and should be given the best of care. If kept clean and properly lubricated, it will give many years of trouble-free service. Before describing the various points which may periodically require lubrication, **IT IS MORE IMPORTANT TO FIRST MENTION THE VARIOUS SPOTS WHICH SHOULD NOT BE LUBRICATED.**

NO LUBRICATION REQUIRED

- Do not lubricate any ball races or any ball bearings.
- Do not lubricate bearing fit of bevel index handle (Item 52, figure 3) in yoke.
- Do not lubricate the motor bearings. These are sealed ball bearings and require no added lubrication.

Do not lubricate bevel latch pin (Item 31, figure 3) in yoke. Do not lubricate between radial arm cap (Item 12, figure 1) and radial arm.

PERIODICALLY LUBRICATE THESE POINTS

Use SAE No. 10-30 Auto Engine Oil.

Apply a few drops of oil along the swivel latch pin (Item 6, figure 3) only if the pin has a tendency to stick. Remove the left-hand carriage cover and use oil sparingly to prevent it from getting on the ball bearings or races.

A light film of oil can be wiped on the face of the column tube (Item 15, figure 1) and keyway to lubricate the fit between this part and the key and column support (Items 21 and 19, figure 2).

Apply a few drops of oil to the bearing surfaces of the elevation crank shaft assembly (Item 29, figure 2). An oiling hole is provided in the elevation shaft bearing bracket (Item 23, figure 2) to facilitate the lubrication of the rear bearing support.

The thread on the elevation shaft assembly (Item 30, figure 2) can be lubricated through the oiling hole in the center of the radial arm cap (Item 12, figure 1).

STANDARD SAW OPERATIONS

CROSS-CUTTING

Cross-cutting is the sawing of wood across the grain. Planks are milled with the grain running the length of the plank. If a straight cross-cut is desired, the board is placed on the saw table against the fence so that the grain is parallel to the fence. See Figure 26.

NOTE

When cross-cutting normal pieces of lumber, the long end of the board should be placed to the left of the saw blade as the board is normally held by the left hand during operation.

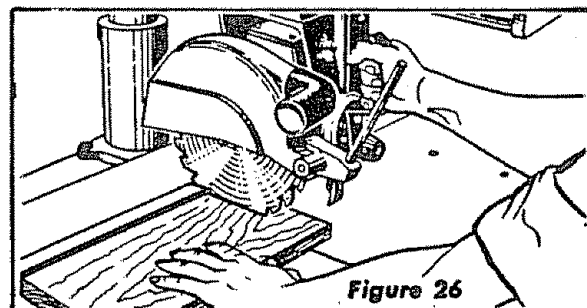

The radial arm must be positioned at 0° as indicated by the radial arm position indicator. The arm latch handle must be indexed and tightened. See page 11 "Angular Movement and Locking of the Radial Arm" for the most accurate setting at the 0° index position. The yoke must be indexed at the 0° position, making the saw blade perpendicular to the rip fence, and the yoke clamp handle placed in the locked position. The bevel index handle must be positioned at 0°, as indicated by the bevel scale, and locked. Turn the elevation crank to lower the saw until the blade teeth are approximately 1/32" below the table surface in the saw slot made when performing the "PRELIMINARY CROSS-CUT AT THE 0° POSITION". Push the saw carriage to the rear of the radial arm so the blade is behind the rip fence. Adjust the saw guard so the bottom is parallel to the table and set the anti-kickback pawl assembly so it just clears the board to be cut. Turn the switch key "On" to start the saw motor. Hold the board firmly against the rip fence with the left hand and grasp the bevel index handle with the right hand. The cut is then made by pulling the carriage forward until the

saw blade cuts through the work.

The carriage will tend to move toward the operator so be prepared to restrain it by keeping your arm straight from the shoulder to the wrist. When the cut is complete, the saw should be returned to the back of the radial arm and the switch key turned "Off". It will be noticed, that the saw blade tends to feed itself through the work due to the rotation of the blade and the direction of feed. Therefore, the operator should develop the habit of holding his right arm straight from the shoulder to the wrist. After this method is used a few times the operator will find that it is necessary to roll or rotate the body from the waist up. If this method is followed, it will become apparent that very little effort is required on the part of the operator to move the saw blade through the work, and in most cases, the right arm is used merely to control the rate of feed of the saw through the board. It will also be found that when cross-cutting a thick board it will be necessary to retard movement of the saw through the work. By holding the right arm (right hand normally grips the saw handle) straight, the operator can easily control the rate of feed, thus preventing the saw blade from overfeeding and stalling the saw motor. This must be avoided whenever possible. In some cases it may become necessary to cross-cut long boards which extend over the saw table on one, or both sides. This can cause buckling of the board and bind the saw during the cut. To eliminate this condition the ends of the board should be supported. Figure 27 illustrates a typical support which can be made and used to facilitate cross-cutting of long lumber.

RIPPING

Ripping is the sawing of wood with the grain. It is always done with the help of the fence as a guide to position and maintain the work at the correct width for the cut. Because the work is pushed along the fence, it must have a reasonably straight edge to make sliding contact with the fence. Also, the work must make solid contact with the table so that it will not wobble or rock. Provide a straight edge, even if this means temporary nailing of an auxiliary straight edge board to the work. If work piece is warped, turn the hollow side down.

Use of the saw guard is always recommended; and the anti-kickback pawl assembly should always be used in both in-rip or out-rip operations. Before ripping and after the saw has been positioned prior to cutting, the saw guard and anti-kickback pawl assembly must be properly adjusted. Loosen the wing nut holding the guard to the motor and lower the nose of the guard to within $\frac{1}{8}$ " above the top surface of the board to be cut. Retighten the wing nut securely.

CAUTION

The nose of the guard refers to that end of the guard which is opposite to the end which mounts the anti-kickback pawl assembly. Always rip from the nose of the guard. See Warning Label on guard.

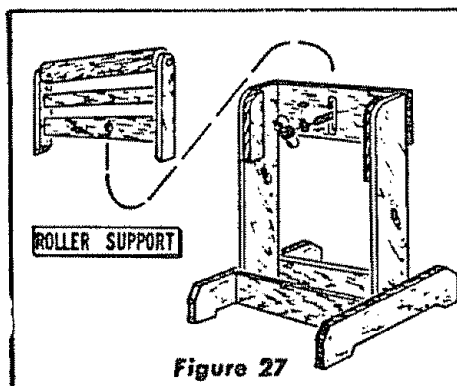

Figure 27

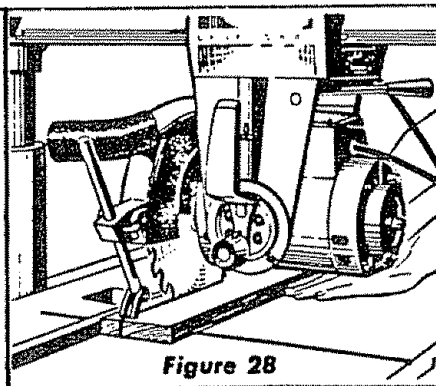

Figure 28

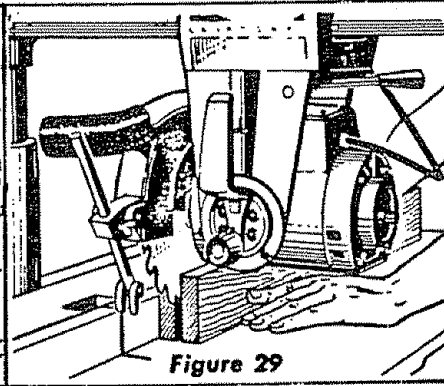

Figure 29

At the opposite end of the guard, loosen the wing screw holding the anti-kickback pawl assembly and lower the assembly until the tips of the pawls are $\frac{1}{8}$ " below the top surface of the board to be cut. Retighten the wing screw securely.

IN-RIPPING—In-rip refers to a position when the blade is between the motor and the fence and parallel to the fence. See Figure 28. To place the saw in this position, unlock the yoke, disengage the swivel latch pin and rotate the yoke 90° clockwise (viewing it from the carriage) until the swivel latch pin automatically indexes the yoke 90°. Relock the yoke. See "Adjustment of Pointers" to check accuracy of "In-Rip" scale reading. Position the motor on the radial arm until the pointer on the "In-Rip" scale indicates the desired width of the finished cut board. Tighten the carriage lock knob securely. Position the discharge elbow on the guard so that sawdust will be blown toward the rear of the saw. Turn the saw "On" and lower the saw blade until it cuts into the table top about $\frac{1}{32}$ ". Turn the saw "Off". Now adjust the saw guard and anti-kickback pawl assembly as described in the paragraph "Ripping". The board to be ripped must be fed into the saw blade from the right side of the table, therefore, the normal position for the operator is also at the right side of the table. With the left hand safely clear of the blade and holding the board to be ripped down against the table and against the face of the fence as a guide, use the right hand to feed the board into the saw. The left hand should remain stationary, serving as a guide only. As the right hand approaches the left hand, hold a push stick with the right hand to complete the cut. Do not leave a long board unsupported so that the spring of the board causes it to shift on the table. A support like that described in "Cross-Cutting" can be used to support the board behind the blade; and if the board is very long, use another support in front of the saw. Ripped boards up to 8 $\frac{1}{2}$ " wide can be cut in the In-Rip position.

OUT-RIPPING—Out-rip refers to a position when the motor is between the blade and the fence. Normally, this position is only used when the width of the required ripped board cannot be cut from the in-rip position. Ripped boards up to 18 $\frac{1}{4}$ " wide can be cut in the out-rip position when the fence is against the front table. If the fence is moved to the extreme rear position against the table clamps, ripped boards up to 25 $\frac{3}{8}$ " wide can be cut. To place the saw in the out-rip position, the yoke must be rotated and indexed 90° counterclockwise from the cross-cut position and locked. The same procedure for sawing is used except that now the operator stands at the left side of the table and a push stick is normally not required.

NOTE

For added table space in front of the blade see "Movement and Position of the Yoke".

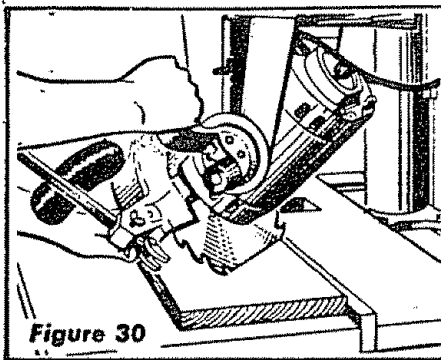

Figure 30

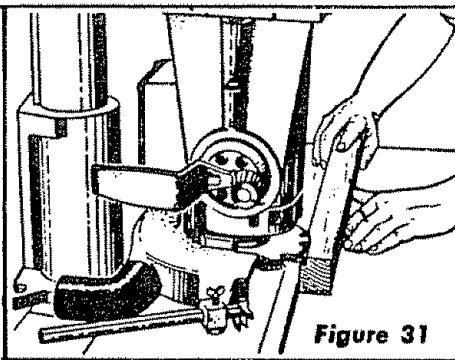

Figure 31

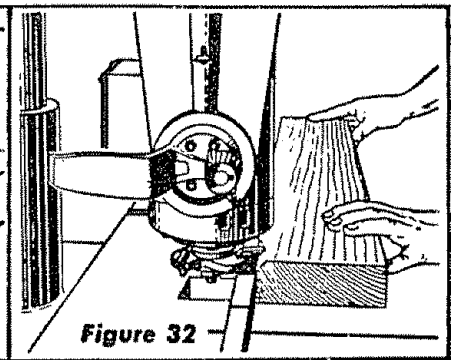

Figure 32

RESAWING

Resawing is the cutting of thick boards into thinner ones. It is a ripping operation. See Figure 29. Small boards—up to 2½" maximum width—can be resawed in one pass; but larger boards up to 5" maximum require two passes, one pass along each edge of the board. When two cuts from opposite edges are required, these should be made to overlap ½" from the approximate center of the board. If the first cut is too deep, the kerf will close and bind the saw on the second cut, with danger of kickback. Also, when the kerf closes, the two sides of the cut are no longer parallel to the saw blade, and the saw will cut into them to spoil their appearance. Keep the same face of the board against the fence when making both cuts.

When cutting boards thicker than 4", a fence should be used which extends 3½" above the table top. When cutting boards thicker than 5", cut both sides and finish the cut with a hand saw.

BEVEL AND MITER CUTS

Bevel cuts can be made from either a cross-cutting or ripping position by tilting the blade to the desired angle. Miter cuts can be made only from a cross-cutting position when the blade and radial arm are at some angle other than 90° to the fence. A bevel miter cut is a cut which is both beveled and mitered. This cut is made with the blade and radial arm set at the desired miter angle to the fence and then the blade only is tilted with respect to the table top to the desired bevel angle. This cut is also referred to as a compound miter. See Figure 30.

USE OF THE DADO HEAD

The dado saw or head, as it is called, is a special set of blades for cutting grooves and dados. Craftsman 8" Krom-edge Dado Set can be purchased at any Sears Retail Store or Mail Order House. The head consists of two outside blades 1/8" thick, six 1/8" thick chipper blades and paper washers for 1/16" width adjustments. With these blades, grooves of 1/8", 1/4", and additional widths increased in steps of 1/16" up to a maximum of 13/16" wide can be cut. *Outside blades can be used alone, chippers cannot.*

When using the maximum width of dado of 13/16" on the motor shaft, the outside loose collar (Item 38, Figure 1) must not be used. The width of the dado can be reduced while using the loose collar and two or more passes can be made with the work to obtain the desired width of cut. Whenever two or more chippers are used, stagger the cutting ends as evenly as possible around the circumference. Fractional adjustments in thickness of the head can be made by using paper washers between the outside blades and chippers. Dado head operations are much the same as those with a standard blade—but the dado head takes a bigger bite, so that the work-piece should be held more firmly. When a groove wider than the dado head is needed, make

two or more passes. Space cuts so that they overlap a trifle. Dado work is done in the cross-cut position. Ploughing is done in the ripping position. If the rip or plough position is used the saw guard and anti-kickback pawl assembly should be adjusted as described in the paragraph "RIPPING". Rabbeting is done in the vertical position. See Figure 31. When rabbeting, the motor is indexed 90° to the vertical position so that the blades are between the table top and the motor and the yoke is indexed 90° clockwise and locked. The saw is moved back on the radial arm and locked to the arm when the amount of the blade extending forward of the fence is equal to the depth of the rabbet desired. If the depth of the rabbet is large, do not attempt to cut it in one operation. Lower the radial arm until the blades are in a position to cut the desired width of rabbet in the edge of the board. The bottom of the saw guard should be parallel to the fence and the discharge elbow directed to the rear of the saw.

MOLDING OR SHAPING

This work is done using the Craftsman Molding Cutter Head and a set of cutters depending on the type of molding cut desired. This work is done with the saw in the same position as that described for rabbeting. See Figure 32. Since the position of the cutters with respect to the fence and the table top can be adjusted any or all of the cutter shapes can be used.

ROUTING AND DOVETAILING

Routing and dovetailing are done with the motor indexed and locked 90° from the horizontal except that this time the externally threaded stub end opposite the normal blade end is between the motor and the table top. The following chucks will mate with this external ½-20 thread: (See Figure 33).

- 0" to 1/4" Key Chuck
- 5/64" to 1/2" Key Chuck

The following routers and dovetails are recommended:

- 1/8" router
- 1/4" router
- 3/8" router
- 1/2" router
- 5/8" router
- 3/8" dovetail
- 1/2" dovetail

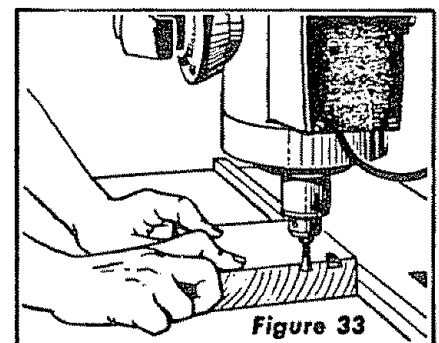

Figure 33

Routing may be done by either moving the work with a stationary router or by clamping the work to the table and moving the router. *Always approach the router bit from the left hand side of the saw.*

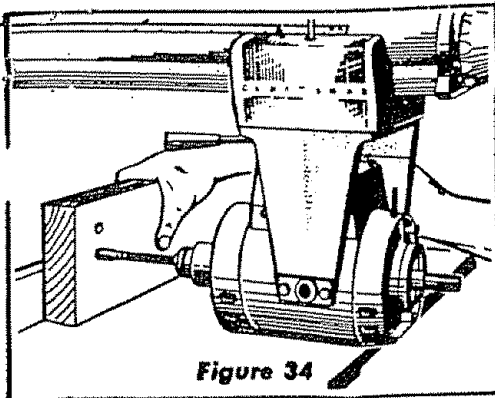

Figure 34

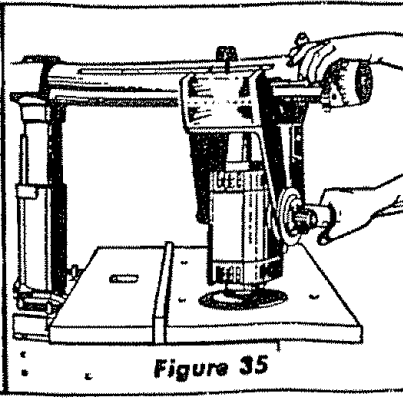

Figure 35

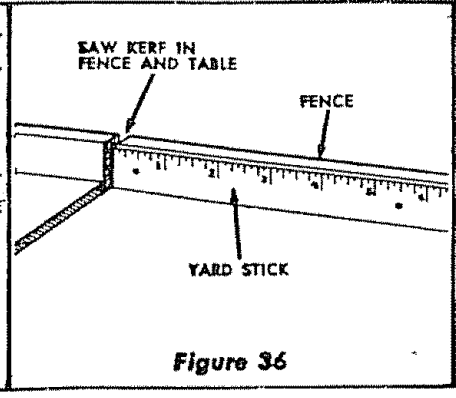

Figure 36

BORING

Your saw can also be converted to a horizontal drill for boring by using one of the recommended chucks and the proper drill. For drilling holes on an angle the radial arm should be positioned to the desired angle while the work is parallel to the fence. See Figure 34.

SANDING

Using the 10" sanding disc mounted on the saw end of the motor, you can convert your saw into a sander which can be operated in any position. The loose collars should be used on both sides of the sanding disc.

STABILIZING WASHERS FOR THIN BLADES

Stabilizing washers should be used with thin blades for improved appearance of the finish cuts.

HELPFUL HINTS

1. The life of the laminated saw table can be greatly lengthened if a 1/4" piece of plywood is tacked to the table top after leveling. Then all cutting can be done in the added piece of plywood instead of the laminated table.
2. There is a possibility that during or after shipment, the wooden front table; spacer board, or rear table might become slightly warped. Lay a straight edge across the surface of the table and check for gaps or high spots on the table. Any portions of the table which are not flat should be planed and sanded until flat. Sanding can be done by using one of the two key chucks referred to under "Routing" and a Craftsman moulded rubber 7" sanding disc.
3. When sanding the table top (See Figure 35) or routing with the work stationary, the arm lock pin can be prevented from automatically indexing at 0° and 45° by rotating the arm latch handle about 6 turns counter-clockwise from the locked position.

4. A scale may be attached to the fence to aid the operator when measuring lengths during cross-cut operations. This can be accomplished by tacking a yard stick to the fence as shown. See Figure 36.
5. In the event that the fence is warped and cannot be straightened by tightening the table clamps proceed as follows: Remove the fence and replace with a temporary fence made from a straight piece of scrap lumber. Proceed to cut slots in the original fence where the gap between the fence and front table was determined to be the greatest. See Figure 37 for slotting. Replace the fence, after slotting, behind the front table with the slots toward the rear and tighten the table clamps.
6. There are three positions in which the fence can be located. See Figure 38.
 1. Normal position.
 2. Position used for maximum cross-cut on 1" material and for greater bevel and miter capacity.

CAUTION

- Rip scales cannot be used in this position.
3. Position used for maximum out-rip capacity.
 7. An auxiliary table top for molding or shaping can be constructed similar to Figure 39. Note the shape of the back guide fence against which your work piece is moved. A cut-out 5" wide should be made at the center of this guide fence to give adequate clearance for the molding head and cutters. Also a wider clearance marked "A" should be made to allow for the radial saw motor. Be sure the front edge of the auxiliary table is parallel with the surface of the guide fence. With the auxiliary table top thus completed it is ready for use by merely clamping it into position with "C" clamps.

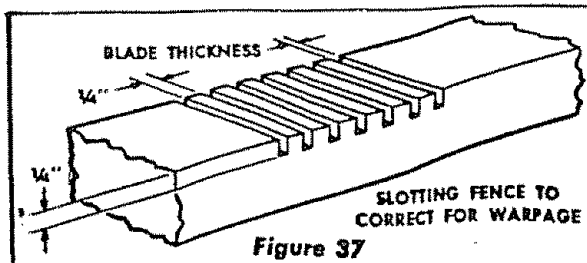

Figure 37

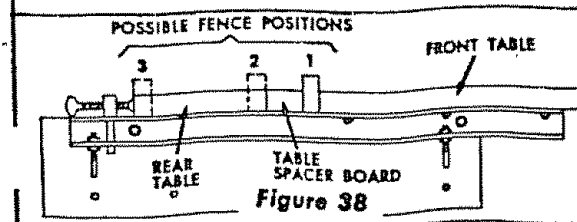

Figure 38

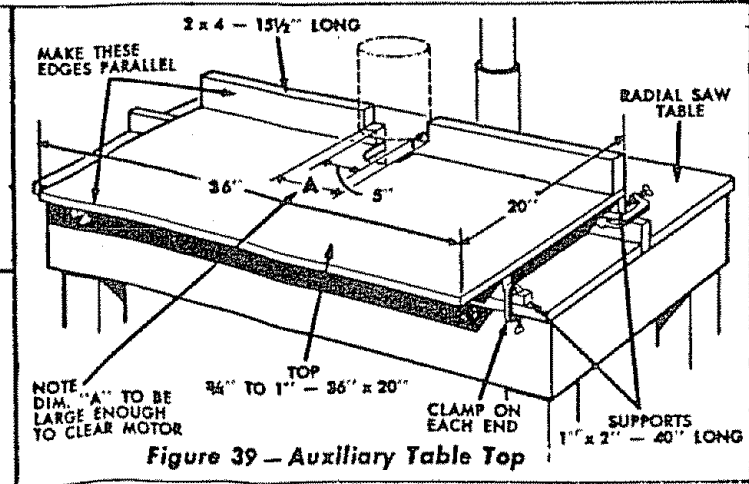

Figure 39 - Auxiliary Table Top

Free Manuals Download Website

<http://myh66.com>

<http://usermanuals.us>

<http://www.somanuals.com>

<http://www.4manuals.cc>

<http://www.manual-lib.com>

<http://www.404manual.com>

<http://www.luxmanual.com>

<http://aubethermostatmanual.com>

Golf course search by state

<http://golfingnear.com>

Email search by domain

<http://emailbydomain.com>

Auto manuals search

<http://auto.somanuals.com>

TV manuals search

<http://tv.somanuals.com>