

Operator's Manual

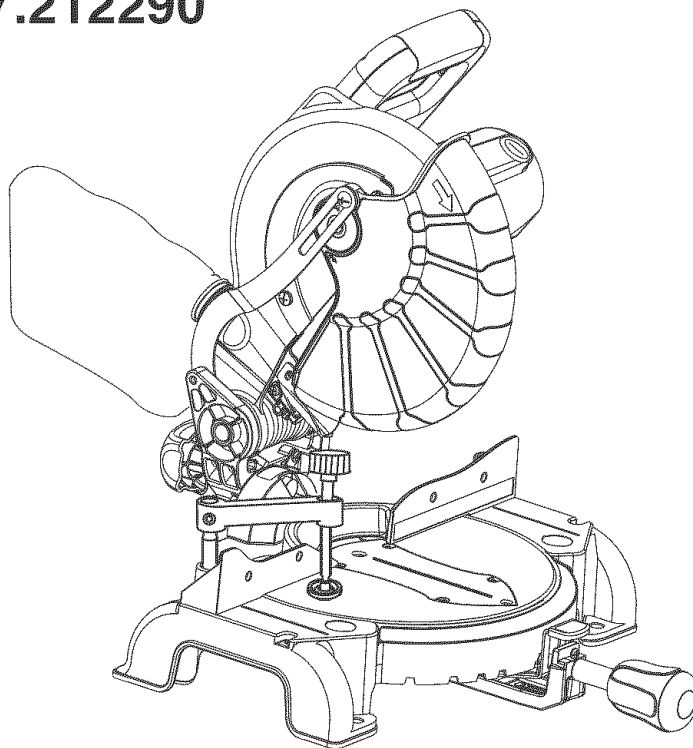

10 in. COMPOUND MITER SAW Model No. 137.212290



CAUTION:

Before using this Miter Saw, read this manual and follow all its Safety Rules and Operating Instructions

- Safety Instructions
- Installation
- Operation
- Maintenance
- Parts List

Customer Help Line
1-800-843-1682

Sears, Roebuck and Co., Hoffman Estates, IL 60179 USA

Visit our Craftsman website: www.sears.com/craftsman

Part No. 137212290001

TABLE OF CONTENTS

SECTION	PAGE	SECTION	PAGE
Warranty	2	Know Your Compound Miter Saw	8
Product Specifications	2	Glossary of Terms	9
Power Tool Safety	3	Assembly and Adjustments	10
Compound Miter Saw Safety	4	Operation	16
Electrical Requirements and Safety	4	Maintenance	23
Accessories and Attachments	6	Troubleshooting Guide	24
Tools Needed for Assembly	6	Parts List	25
Carton Contents	7		

WARRANTY

ONE-YEAR FULL WARRANTY ON CRAFTSMAN TOOL

If this Craftsman tool fails due to a defect in material or workmanship within one year from the date of purchase, **CALL 1-800-4-MY-HOME® TO ARRANGE FOR FREE REPAIR.**

If this tool is used for commercial or rental purposes, this warranty will apply for only ninety days from the date of purchase. This warranty applies only while this tool is in the United States.

This warranty gives you specific legal rights, and you may also have other rights, which vary, from state to state.

Sears, Roebuck & Co., Dept. 817 WA, Hoffman Estates, IL 60179

WARNING

Some dust created by power sanding, sawing, grinding, drilling and other construction activities contains chemicals known to cause cancer, birth defects or other reproductive harm. Some examples of these chemicals are:

- Lead from lead-based paints
- Crystalline silica from bricks, cement and other masonry products
- Arsenic and chromium from chemically treated lumber

Your risk from these exposures varies, depending on how often you do this type of work. To reduce your exposure to these chemicals, work in a well ventilated area and work with approved safety equipment such as dust masks that are specially designed to filter out microscopic particles.

PRODUCT SPECIFICATIONS

MOTOR

Power Source	120V AC, 60Hz, 15 Amp	Bevel 45° L	1-9/16 in. x 5-1/2 in.
Arbor Shaft Size	5/8 in.	45° Miter and 45° Bevel	1-9/16 in. x 3-1/2 in.
Speed	4800 RPM (No load)	Rotating Table:	
Brake	Electric	Miter Detent Stops	0, 15, 22.5, 31.6, 45° R & L
Double Insulated	Yes	Bevel Positive Stops	0, 45°

MITER SAW

Cutting Capacity:

Crosscut	2-5/8 in. x 5-1/2 in.
Miter 45° R & L	2-5/8 in. x 3-1/2 in.

WARNING

To avoid electrical hazards, fire hazards or damage to the tool, use proper circuit protection.

This tool is wired at the factory for 110-120 Volt operation. It must be connected to a 110-120 Volt / 15 Ampere time delay fuse or circuit breaker. To avoid shock or fire, replace power cord immediately if it is worn, cut or damaged in any way. Before using your tool, it is critical that you read and understand these safety rules.

Failure to follow these rules could result in serious injury to you or damage to the tool.

POWER TOOL SAFETY

GENERAL SAFETY INSTRUCTIONS BEFORE USING THIS POWER TOOL

Safety is a combination of common sense, staying alert and knowing how to use your power tool.

WARNING

To avoid mistakes that could cause serious injury, do not plug the tool in until you have read and understood the following.

- 1. READ** and become familiar with the entire Operators Manual. **LEARN** the tool's application, limitations and possible hazards.
- 2. KEEP GUARDS IN PLACE** and in working order.
- 3. REMOVE ADJUSTING KEYS AND WRENCHES.** Form the habit of checking to see that keys and adjusting wrenches are removed from the tool before turning ON.
- 4. KEEP WORK AREA CLEAN.** Cluttered areas and benches invite accidents.
- 5. DO NOT USE IN DANGEROUS ENVIRONMENTS.** Do not use power tools in damp locations, or expose them to rain or snow. Keep work area well lit.
- 6. KEEP CHILDREN AWAY.** All visitors and bystanders should be kept a safe distance from work area.
- 7. MAKE WORKSHOP CHILD PROOF** with padlocks, master switches or by removing starter keys.
- 8. DO NOT FORCE THE TOOL.** It will do the job better and safer at the rate for which it was designed.
- 9. USE THE RIGHT TOOL.** Do not force the tool or an attachment to do a job for which it was not designed.
- 10. USE PROPER EXTENSION CORDS.** Make sure your extension cord is in good condition. When using an extension cord, be sure to use one heavy enough to carry the current your product will draw. An undersized cord will result in a drop in line voltage and in loss of power which will cause the tool to overheat. The table on page 5 shows the correct size to use depending on cord length and nameplate ampere rating. If in doubt, use the next heavier gauge. The smaller the gauge number, the heavier the cord.
- 11. WEAR PROPER APPAREL.** Do not wear loose clothing, gloves, neckties, rings, bracelets, or other jewelry which may get caught in moving parts. Nonslip footwear is recommended. Wear protective hair covering to contain long hair.
- 12. ALWAYS WEAR EYE PROTECTION.** Any power tool can throw foreign objects into the eyes and could cause permanent eye damage. **ALWAYS** wear Safety Goggles (not glasses) that comply with ANSI Safety standard Z87.1 Everyday eyeglasses have only impact-resistant lenses. They **ARE NOT** safety glasses. Safety Goggles are available at Sears. **NOTE:** Glasses or goggles not in compliance with ANSI Z87.1 could seriously injure you when they break.

- 13. WEAR A FACE MASK OR DUST MASK.** Sawing operation produces dust.
- 14. SECURE WORK.** Use clamps or a vise to hold work when practical. It's safer than using your hand and it frees both hands to operate the tool.
- 15. DISCONNECT TOOLS FROM POWER SOURCE** before servicing, and when changing accessories such as blades, bits and cutters.
- 16. REDUCE THE RISK OF UNINTENTIONAL STARTING.** Make sure switch is in the OFF position before plugging the tool in.
- 17. USE RECOMMENDED ACCESSORIES.** Consult this Operator's Manual for recommended accessories. The use of improper accessories may cause risk of injury to yourself or others.
- 18. NEVER STAND ON THE TOOL.** Serious injury could occur if the tool is tipped or if the cutting tool is unintentionally contacted.
- 19. CHECK FOR DAMAGED PARTS.** Before further use of the tool, a guard or other part that is damaged should be carefully checked to determine that it will operate properly and perform its intended function – check for alignment of moving parts, binding of moving parts, breakage of parts, mounting, and any other conditions that may affect its operation. A guard or other part that is damaged should be properly repaired or replaced.
- 20. NEVER LEAVE THE TOOL RUNNING UNATTENDED. TURN THE POWER "OFF".** Do not walk away from a running tool until the blade comes to a complete stop and the tool is unplugged from the power source.
- 21. DO NOT OVERREACH.** Keep proper footing and balance at all times.
- 22. MAINTAIN TOOLS WITH CARE.** Keep tools sharp and clean for best and safest performance. Follow instructions for lubricating and changing accessories.
- 23. WARNING:** Dust generated from certain materials can be hazardous to your health. Always operate saw in well-ventilated area and provide for proper dust removal.

COMPOUND MITER SAW SAFETY

SPECIFIC SAFETY INSTRUCTIONS FOR THIS COMPOUND MITER SAW

- 1. USE ONLY CROSS-CUTTING SAW BLADES.**
When using carbide tipped blades, make sure they have a negative hook angle.
IMPORTANT: DO NOT USE THIN KERF BLADES- they can deflect and contact guard and can cause possible injury to the operator.
- 2. DO NOT** operate the miter saw until it is completely assembled and installed according to these instructions.
- 3. IF YOU ARE NOT** thoroughly familiar with the operation of miter saws, seek guidance from your supervisor, instructor, or other qualified person.
- 4. ALWAYS** hold the work firmly against the fence and table. **DO NOT** perform any operation free hand (use clamp wherever possible).
- 5. KEEP HANDS** out of the path of the saw blade. If the workpiece you are cutting would cause your hands to be within 6-3/4 inches of the saw blade, the workpiece should be clamped in place before making the cut.
- 6. BE SURE** the blade is sharp runs freely and is free of vibration.
- 7. ALLOW** the motor to come up to full speed before starting a cut.
- 8. KEEP THE MOTOR AIR SLOTS CLEAN** and free of chips or dust.
- 9. ALWAYS MAKE SURE** all handles are tight before cutting, even if the table is positioned in one of the positive stops.
- 10. BE SURE** both the blade and the collar are clean and the arbor bolt is tightened securely.
- 11. USE** only blade collars specified for your saw.
- 12. NEVER** use blades larger in diameter than 10 inches.
- 13. NEVER** apply lubricants to the blade when it is running.
- 14. ALWAYS** check the blade for cracks or damage before operation. Replace a cracked or damaged blade immediately.
- 15. NEVER** use blades recommended for operation at less than 4800 RPM.
- 16. ALWAYS** keep the blade guards in place and use at all times.
- 17. NEVER** reach around the saw blade.

- 18. MAKE SURE** the blade is not contacting the workpiece before the switch is turned ON.
- 19. IMPORTANT:** After completing the cut, release the trigger and wait for the blade to stop before returning the saw to the raised position.
- 20. MAKE SURE** the blade has come to a complete stop before removing or securing the workpiece, changing the workpiece angle, or changing the angle of the blade.
- 21. NEVER** cut metals or masonry products with this tool. This miter saw is designed for use on wood and wood-like products.
- 22. NEVER** cut small pieces. If the workpiece being cut would cause your hand or fingers to be within 6-3/4 inches of the saw blade the workpiece is too small.
- 23. PROVIDE** adequate support to the sides of the saw table for long work pieces.
- 24. NEVER** use the miter saw in an area with flammable liquids or gases.
- 25. NEVER** use solvents to clean plastic parts. Solvents could possibly dissolve or otherwise damage the material.
- 26. SHUT OFF** the power before servicing or adjusting the tool.
- 27. DISCONNECT** the saw from the power source and clean the machine when finished using.
- 28. MAKE SURE** the work area is clean before leaving the machine.
- 29. SHOULD** any part of your miter saw be missing, damaged, or fail in any way, or any electrical component fail to perform properly, lock the switch and remove the plug from the power supply outlet. Replace missing, damaged, or failed parts before resuming operation.

ELECTRICAL REQUIREMENTS

POWER SUPPLY AND MOTOR SPECIFICATIONS
The AC motor used in this saw is a universal, nonreversible type. See "MOTOR" in the "PRODUCT SPECIFICATIONS" section on page 2.

WARNING

To avoid electrical hazards, fire hazards, or damage to the tool, use proper circuit protection. Your saw is wired at the factory for 120V operation. Connect to a 120V, 15 Amp circuit and use a 15 amp. time delay fuse or circuit breaker. To avoid shock or fire, if power cord is worn or cut, or damaged in any way, have it replaced immediately.

ELECTRICAL REQUIREMENTS AND SAFETY

ELECTRICAL REQUIREMENTS – cont'd DOUBLE INSULATED

The power tool is double insulated to provide a double thickness of insulation between you and tool's electrical system. All exposed metal parts are isolated from the internal metal motor components with protecting insulation.

Replacement parts – When servicing use only identical replacement parts.

Polarized plugs – This saw has a plug that looks like the one shown below:

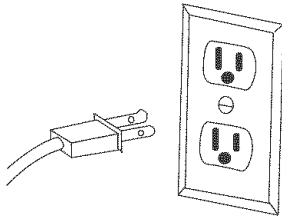

To reduce the risk of electrical shock, this saw has a polarized plug (one blade is wider than the other). This plug will fit in a polarized outlet only one way. If the plug does not fit fully in the outlet, reverse the plug. If it still does not fit, contact a qualified electrician to install the proper outlet. Do not change the plug in any way.

WARNING

Double insulation does not take the place of normal safety precautions when operating this tool.

To avoid electrocution:

1. **Use only identical replacement parts when servicing a tool with double insulation. Servicing should be performed by a qualified technician.**
2. **Do not use power tools in wet or damp locations or expose them to rain or snow.**

MOTOR SAFETY PROTECTION IMPORTANT:

To avoid motor damage, the motor should be blown out or vacuumed frequently to keep sawdust from interfering with the motor ventilation.

1. **CONNECT** this saw to a 120V, 15 amp. circuit with a 15 amp. time delay fuse or circuit breaker. Using the wrong size fuse can damage the motor.
2. If the motor won't start, release the trigger switch immediately. **UNPLUG THE SAW.** Check the saw blade to make sure it turns freely. If the blade is free, try to start the saw again. If the motor still does not start, refer to the **"TROUBLESHOOTING GUIDE"**
3. If the tool suddenly stalls while cutting wood, release the trigger switch, unplug the tool, and free the blade from the wood. The saw may now be started and the cut finished

4. **FUSES** may "blow" or circuit breakers may trip frequently if:
 - a. **MOTOR** is overloaded – overloading can occur if you feed too rapidly or make too many start/stops in a short time.
 - b. **LINE VOLTAGE** is more than 10% above or below the nameplate voltage rating. For heavy loads, the voltage at motor terminals must equal the voltage specified on the nameplate.
 - c. **IMPROPER** or dull saw blades are used.
5. Most motor troubles may be traced to loose or incorrect connections, overload, low voltage or inadequate power supply wiring. Always check the connections, the load and supply circuit if the motor doesn't run well. Check minimum gauge for the length of cord you are using on the chart below.

GUIDELINES FOR EXTENSION CORDS

Use a proper extension cord. Make sure your extension cord is in good condition. When using an extension cord, be sure to use one heavy enough to carry the current your product will draw. An undersized cord will cause a drop in line voltage, resulting in loss of power and cause overheating. The table below shows the correct size to use depending on cord length and nameplate ampere rating. If in doubt, use the next heavier gauge. The smaller the gauge number, the heavier the cord.

Be sure your extension cord is properly wired and in good condition. Always replace a damaged extension cord or have it repaired by a qualified person before using it. Protect your extension cords from sharp objects, excessive heat and damp or wet areas.

Use a separate electrical circuit for your tools.

This circuit must not be less than # 12 wire and should be protected with a 15 Amp time delay fuse. Before connecting the tool to the power line, make sure the switch is in the OFF position and the electric current is rated the same as the current stamped on the motor nameplate, running at a lower voltage will damage the motor.

MINIMUM GAUGE FOR EXTENSION CORDS (AWG)					
(When using 120 volts only)					
Ampere Rating		Total length of Cord			
More Than	Not More Than	25ft.	50ft.	100ft.	150ft.
0	6	18ft.	16ft.	16ft.	14ft.
6	10	18ft.	16ft.	14ft.	12ft.
10	12	16ft.	16ft.	14ft.	12ft.
12	16	14ft.	12ft.	Not Recommended	

CAUTION: In all cases make certain the receptacle in question is properly grounded. If you are not sure have a certified electrician, check the receptacle.

ACCESSORIES AND ATTACHMENTS

RECOMMENDED ACCESSORIES

▲ WARNING

- Use only accessories recommended for this miter saw. Follow instructions that accompany accessories. Use of improper accessories may cause hazards.
- The use of any cutting tool except 10 inch saw blades which meet the requirements under recommended accessories is prohibited. Do not use accessories such as shaper cutters or dado sets. Ferrous metal cutting and the use of abrasive wheels is prohibited.
- Do not attempt to modify this tool or create accessories not recommended for use with this tool. Any such alteration or modification is misuse and could result in a hazardous condition leading to possible serious injury.

ACCESSORIES

Visit your Sears Hardware Department or see the Sears Power and Hand Tool Catalog to purchase recommended accessories for this power tool.

▲ WARNING

To avoid the risk of personal injury, do not modify this power tool or use accessories not recommended by Sears.

▲ WARNING

Read warnings and conditions on your **CARBIDE TIPPED SAW BLADE**. Do not operate the saw without the proper saw blade guard in place. Carbide is a very hard but brittle material. Care should be taken while mounting, using, and storing carbide tipped blades to prevent accidental damage. Slight shocks, such as striking the tip while handling, can seriously damage the blade. Foreign objects in the workpiece, such as wire or nails, can also cause tips to crack or break off. Before using, always visually examine the blade and tips for bent blade, cracks, breakage, missing or loose tips, or other damage. Do not use if damage is suspected. Failure to heed safety instructions and warnings can result in serious bodily injury.

TOOLS NEEDED FOR ASSEMBLY

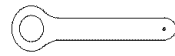

Blade Wrench (supplied)

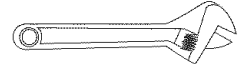

Adjustable Wrench

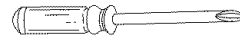

Philips Screwdriver



Hex Key 2.5 mm

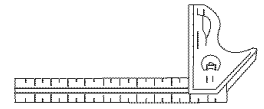

Combination Square

COMBINATION SQUARE MUST BE TRUE

Draw light line on board along this edge.

Straight edge or a 3/4 in. board, this edge must be perfectly straight.

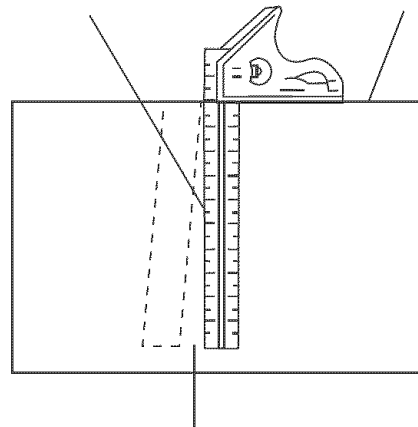

Should not gap or overlap when square is flipped over (see dotted figure).

CARTON CONTENTS

UNPACKING YOUR MITER SAW

▲ WARNING

To avoid injury from unexpected starting or electrical shock, do not plug the power cord into a source of power during unpacking and assembly. This cord must remain unplugged whenever you are working on the saw.

1. Remove the miter saw from the carton.

IMPORTANT: Do not lift miter saw by the Trigger Switch handle. It may cause misalignment. Only lift machine by the base Hand Holds.

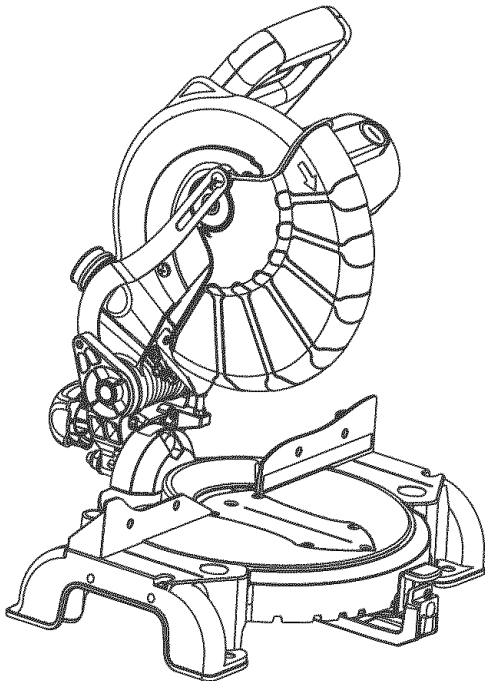

Machine

2. Place the saw on a secure stationary work surface.
3. Separate all parts from the packing material. Check each one with the illustration to make certain all items are accounted for, before discarding any packing material.

▲ WARNING

If any part is missing or damaged, do not attempt to assemble the miter saw, or plug in the power cord until the missing or damaged part is correctly replaced. To avoid electric shock, use only identical replacement parts when servicing double insulated tools.

- To purchase replacement parts, call 1-800-469-4663.
- For missing or damaged parts upon initial purchase, call 1-800-843-1682.

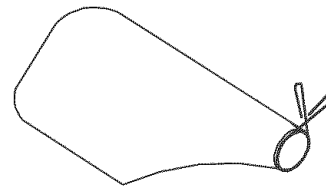

Dust Bag

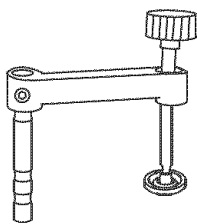

Hold -Down Clamp

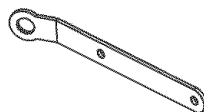

Blade Wrench



Miter Table Handle

KNOW YOUR COMPOUND MITER SAW

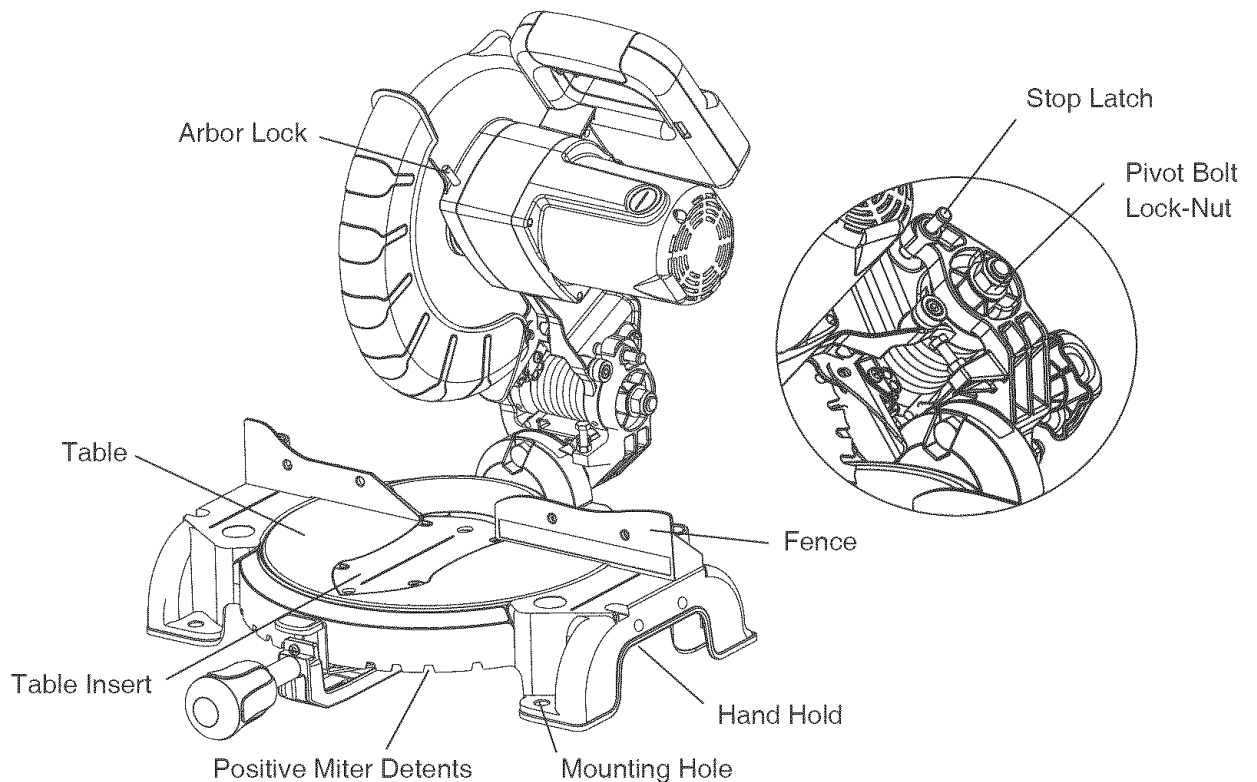
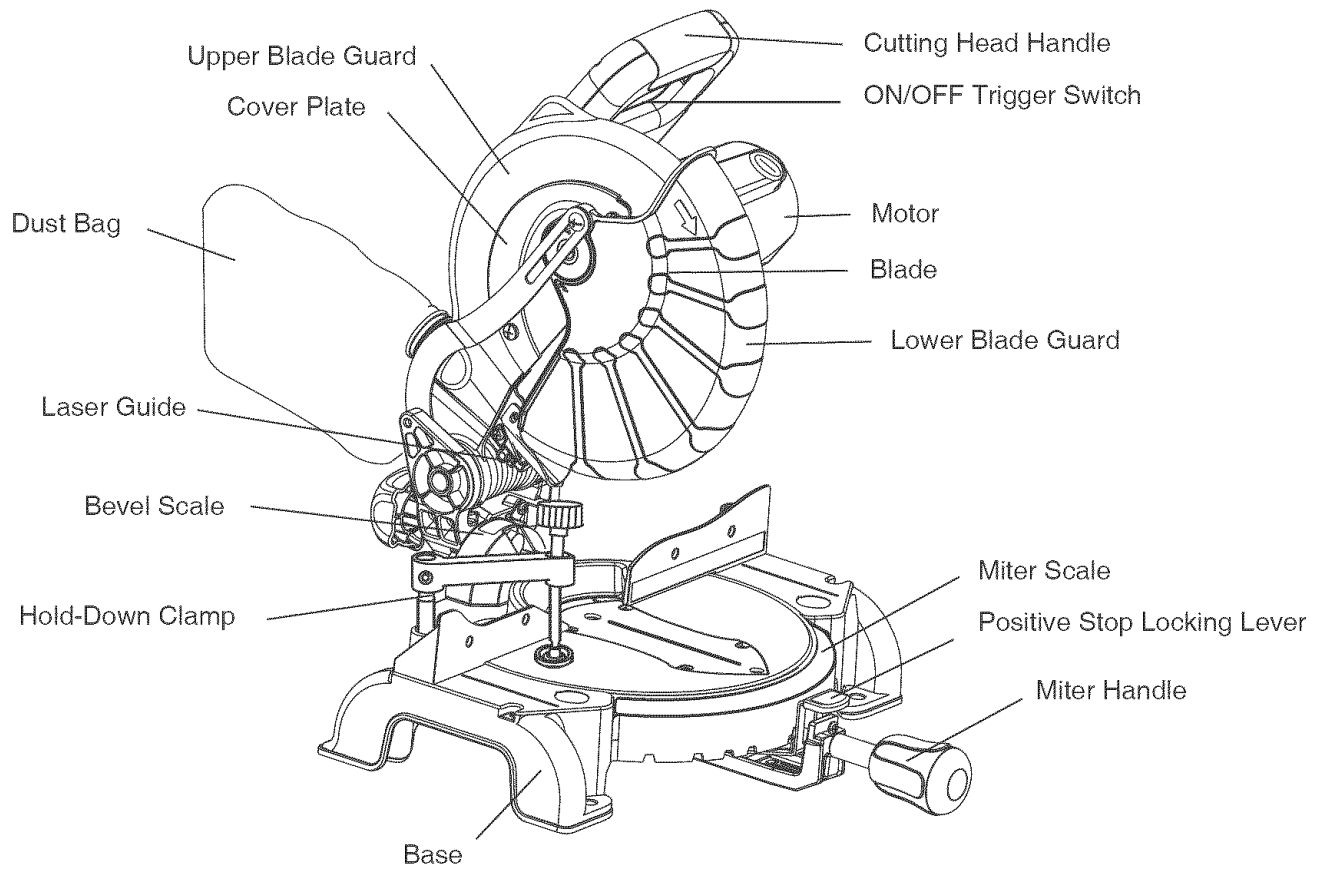

GLOSSARY OF TERMS

COMPOUND MITER SAW TERMS

ARBOR LOCK – Allows the user to keep the blade from rotating while tightening or loosening the arbor bolt during blade replacement or removal.

BASE – Supports the table, holds accessories and allows for workbench or leg set mounting.

BEVEL LOCKING HANDLE – Locks the miter saw at a desired bevel angle.

BEVEL SCALE – To measure the bevel angle of the saw blade 0° to 45° left.

COVER PLATE SCREW – Loosen this screw and rotate the plate for access to the blade arbor bolt.

FENCE – Helps to keep the workpiece from moving when sawing. Scaled to assist with accurate cutting.

HAND HOLD – For moving the saw when unplugged.

ON/OFF TRIGGER SWITCH – To start the tool, squeeze the trigger. Release the trigger to turn off the miter saw.

LOWER BLADE GUARD – Helps protect your hands from the blade in the raised position, it retracts as the blade is lowered.

MITER HANDLE – Use to lock and unlock the miter table, and to rotate the saw to a right or left cutting position.

MITER SCALE – Measures the miter angle 0° to 45° left and right.

POSITIVE STOP LOCKING LEVER – With the miter handle, locks the miter saw at a preset positive stop for the desired miter angle.

MOUNTING HOLES – To mount the miter saw to a stable surface.

STOP LATCH – Locks the miter saw in the lowered position for compact storage and transportation.

SWITCH HANDLE – The cutting head handle contains the trigger switch. The blade is lowered into the workpiece by pushing down on the handle. The saw will return to its upright position when the handle is released.

WARNING LABELS – Read and understand for your own safety. Make sure all labels are present on machine and legible.

WRENCH STORAGE – Convenient storage to prevent misplacing the blade wrench.

WOODWORKING TERMS

ARBOR – The shaft on which a blade is mounted.

BEVEL CUT – An angle cut made through the face of the workpiece.

COMPOUND CUT – A simultaneous bevel and miter cut.

CROSS CUT – A cut made across the width of the workpiece.

FREEHAND – Performing a cut without using a fence (guide), hold down or other proper device to prevent the workpiece from twisting during the cutting operation.

GUM – A sticky s-ap from wood products.

HEEL – Misalignment of the blade.

KERF – The amount of material removed by blade cut.

MITER CUT – An angle cut made across the width of the workpiece.

RESIN – A sticky sap that has hardened.

REVOLUTIONS PER MINUTE (RPM) – The number of turns completed by a spinning object in one minute.

SAW BLADE PATH – The area of the workpiece or table top directly in line with the travel of the blade or the part of the workpiece which will be cut.

SET – The distance between two saw blade tips, bent outward in opposite directions to each other. The further apart the tips are, the greater the set.

WORKPIECE – The item being cut. The surfaces of a workpiece are commonly referred to as faces, ends, and edges.

ASSEMBLY AND ADJUSTMENTS

INSTALLING THE MITER HANDLE (FIG. B)

1. Thread the miter handle (1) into the hole (2) located at the front of the miter table.

Fig. B

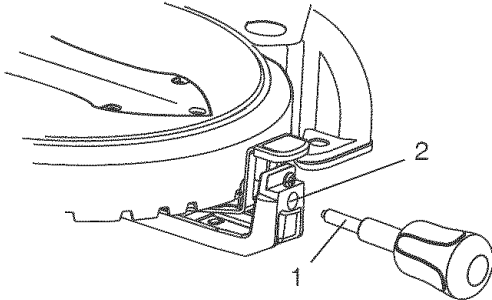

SAW BLADE WRENCH (FIG. C)

1. For convenient storage and prevention of loss, there is a slot (1) in the rear of the cutting head handle (2) for storing the blade wrench (3) when not in use.

Fig. C

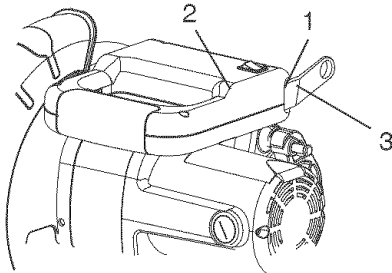

CUTTING HEAD (FIG. D)

Raising

1. Push down slightly on the cutting handle (1).
2. Pull out the stop latch knob (2).
3. Allow the cutting head (3) to raise to the up position.

▲ WARNING

To avoid injury and damage to the saw, transport or store the miter saw with the cutting head locked in the down position. Never use the stop latch to hold the cutting head in a down position for cutting operations.

Fig. D

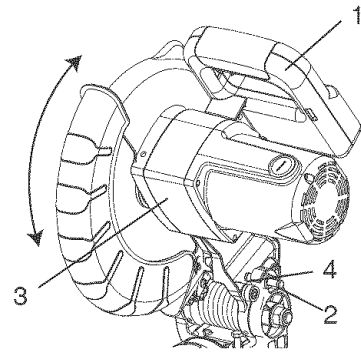

Locking

When transporting or storing the miter saw, the cutting head should always be locked in the down position.

4. Push the cutting head (3) down to its lowest position.
5. Push the stop latch (2) into the locking hole (4).

IMPORTANT: To avoid damage, never carry the miter saw by the switch handle, the cutting arm, or the miter table handle.

INSTALLING THE DUST BAG (FIG. E)

1. Squeeze the metal collar wings (2) of the dust bag (1).
2. Place the dust bag neck opening around the exhaust port (3), and release the metal collar wings.

Fig. E

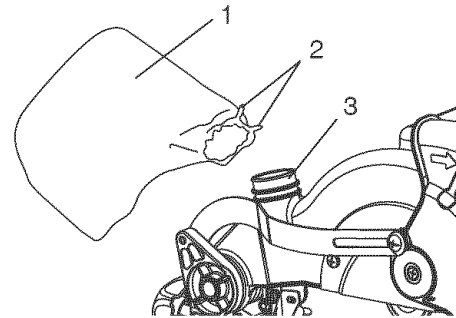

REMOVING OR INSTALLING THE BLADE

▲ WARNING

Only use a 10-inch diameter blade.

To avoid injury from an accidental start, make sure the switch is in the OFF position and plug is not connected to the power source outlet.

REMOVING (FIG. G, G-1, G-2)

1. Unplug the saw from the outlet.
2. Allow the miter saw to rise to the upright position. Raise the lower blade guard (1) to the up position. (Fig. G)
3. Loosen the cover plate screw (2) with a Phillips screwdriver.
4. Rotate the cover plate (3) towards the rear of the tool to expose the arbor bolt (4).
5. Place the blade wrench over the arbor bolt.

Fig. G

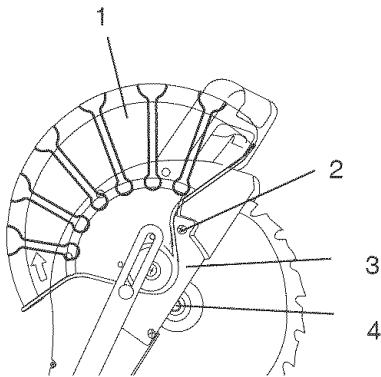

6. Locate the arbor lock (5) on the motor, below the miter saw switch handle. (Fig. G-1)
7. Press the arbor lock, holding it in firmly while turning the blade wrench clockwise. The arbor lock will engage after turning the wrench. Continue to hold the arbor lock in to keep it engaged, while turning the wrench clockwise to loosen the arbor bolt.

Fig. G-1

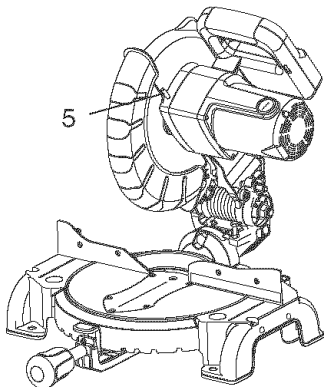

8. Remove the arbor bolt (4), outer blade collar (6), and the blade (7). Do not remove the inner blade collar. (Fig. G-2)

NOTE: Pay attention to the pieces removed, noting their position and direction they face. Wipe the blade collars clean of any sawdust before installing the new blade.

Fig. G-2

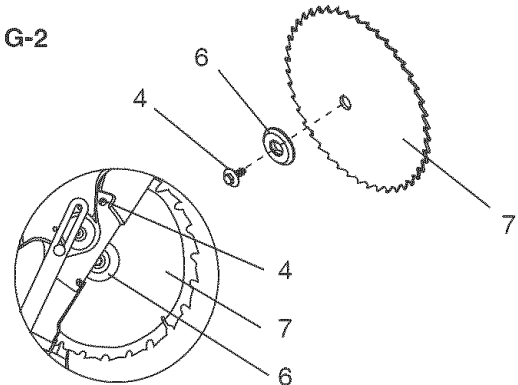

INSTALLING THE BLADE (FIG. G, G-1, G-2)

1. Install a 10 in. blade, making sure the rotation arrow on the blade matches the clockwise rotation arrow on the upper guard, and the blade teeth are pointing downward.
 2. Place the outer blade collar (6) against the blade and on the arbor. Thread the arbor bolt (4) into the arbor counterclockwise. (Fig. G-2)
- IMPORTANT:** Make sure the flats of the blade collars are engaged with the flats on the arbor shaft.
3. Place the blade wrench on the arbor bolt.
 4. Press the arbor lock (5), holding it in firmly while turning the blade wrench counterclockwise. When it engages, continue to press the arbor lock in, while tightening the arbor bolt securely. (Fig. F)
 5. Rotate the cover plate (3) back until the slot in the cover plate engages with the cover plate screw (2). Tighten the screw with a Phillips screwdriver. Lower the blade guard.
 6. Be sure the arbor lock is released so the blade turns freely.

▲ WARNING

- To avoid injury, never use the saw without the cover plate secure in place. It keeps the arbor bolt from falling out if it accidentally loosens, and helps prevent the spinning blade from coming off the saw.
- Make sure the collars are clean and properly arranged. Lower the blade into the table and check for any contact with the metal base or the turn table.

INSTALLING THE HOLD-DOWN CLAMP ASSEMBLY (FIG. H)

1. Place the hold-down clamp assembly (1) in one of the mounting holes (2).

▲ WARNING

When using stop block on the right side, hold-down clamp must also be in right side. Using hold-down clamp on the left side during this operation can cause kickback and serious injury to the operator.

Fig. H

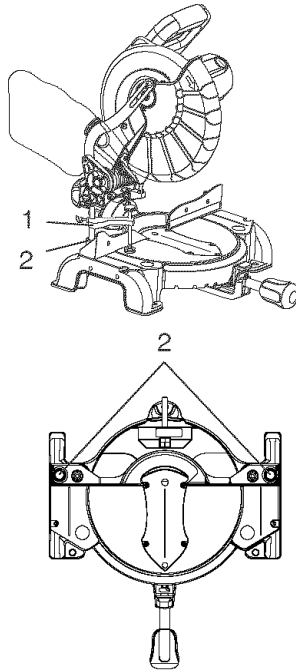

ADJUSTMENT INSTRUCTIONS

▲ WARNING

To avoid injury from an accidental start, make sure the switch is in the OFF position and the plug is not connected to the power source outlet.

ADJUSTING FENCE SQUARENESS (FIG. I)

1. Loosen the four fence locking bolts (1).
2. Lower the cutting arm and lock in position.
3. Using a square, lay the heel of the square against the blade, and the rule against the fence (2) as shown. Check to see if the fence is 90° to the blade.
4. If not, adjust fence 90° to the blade and tighten the fence locking bolts.

CAUTION: If the saw has not been used recently, recheck blade squareness to the fence and readjust if needed.

Fig. I

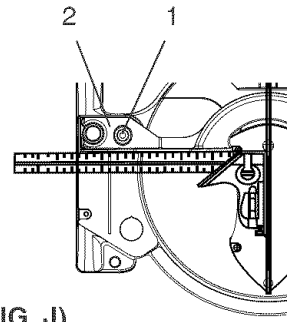

MITER SCALE (FIG. J)

The miter scale assists the user in setting the desired miter angles from 47° left to 47° right. The miter saw table has nine of the most common angle settings with positive stops at 0°, 15°, 22.5°, 31.6°, and 45°. These positive stops position the blade at the desired angle quickly and accurately.

To Adjust the Angle:

1. Unlock the miter table by turning the miter handle (1) counterclockwise.
2. Press down the positive stop locking lever (2) while holding the miter handle, and rotate the table left or right to the desired angle.
3. Release positive stop locking lever. Tighten miter handle.

To Adjust the Indicator:

1. Position the miter table at zero degrees.
2. Loosen the pointer screw (4) and adjust the indicator to the 0° mark on the miter scale and retighten the screw.

Fig. J

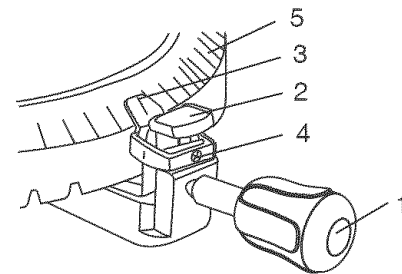

CUTTING ARM TRAVEL (FIG. K)

Cutting arm pivot adjustment

The up and down pivot movement of the cutting arm (1) should not be too tight, restricting movement, nor too loose, affecting the accuracy of the saw cut. The correct locking nut (2) adjustment is snug, allowing no side-to-side arm movement. To adjust, tighten or loosen the adjusting nut (2).

Fig. K

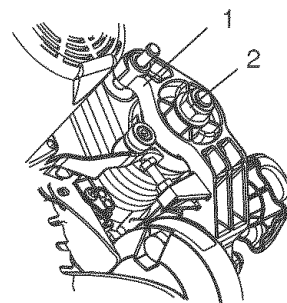

Cutting head downward travel adjustment (FIG. L)

▲ WARNING

To avoid injury from unexpected starting or electrical shock, turn the switch OFF and remove the power cord from the power source.

NOTE: Before each cutting operation, check the position of the blade to make sure it does not contact any metal surface. If the blade contacts any metal surface, the depth of travel must be adjusted.

1. Lower the blade as far as possible.
2. Loosen the locknut (3).
3. Turn the adjustment bolt (4) out (counterclockwise) to decrease the cutting depth or in (clockwise) to increase the cutting depth.
4. Rotate the blade manually to check for contact.
5. Repeat until adjusted properly, and tighten the locknut to secure the adjustment bolt into position.

Fig. L

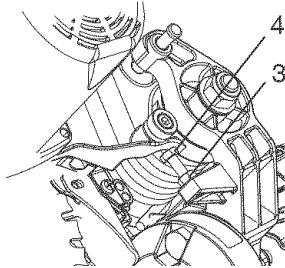

BEVEL STOP ADJUSTMENT (FIG. M & N)

▲ WARNING

To avoid injury from unexpected starting or electrical shock, make sure the trigger is released and remove the power cord from the power source.

90°(0°) Bevel adjustment (Fig. M)

1. Loosen bevel lock handle (1) and tilt the cutting arm completely to the right. Tighten the bevel lock handle. Lower blade.
2. Place a combination square (2) on the miter table with the rule against the table and the heel of the square against the saw blade.
3. If the blade is not 90°(0°) square with the miter table, loosen the bevel lock handle, tilt the cutting head completely to the left, loosen the jamb nut (4) on the bevel angle adjustment bolt (3) and adjust the bolt (3) in or out to increase or decrease the bevel angle with a 10 mm wrench.
4. Tilt the cutting arm to back to the right at 90°(0°) bevel and recheck for alignment.
5. Repeat steps 1 through 4 if further adjustment is needed.
6. Tighten bevel lock handle and jamb nut (4) when alignment is achieved.

Fig. M

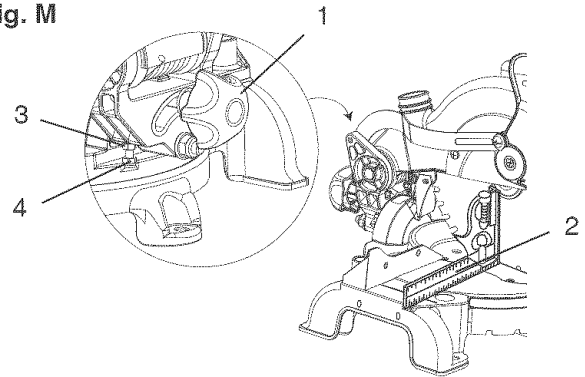

90°(0°) Bevel indicator (Fig. M-1)

1. When the blade is exactly 90°(0°) to the table, loosen the bevel indicator screw (5) using a #2 Phillips screwdriver.
2. Adjust bevel indicator (6) to the "0" mark (7) on the bevel scale and retighten the screw.

Fig. M-1

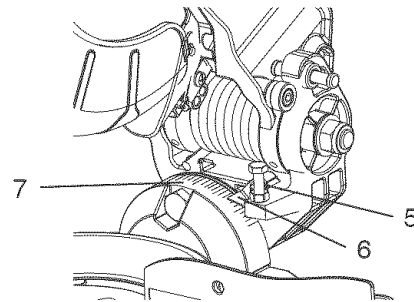

45° Bevel adjustment (Fig. N)

1. Unlock the bevel lock handle and tilt the cutting arm as far to the left as possible.
2. Using a combination square, check to see if the blade angle is 45° to the table.
3. If the blade is not at 45° to the miter table, tilt the cutting arm to the right, loosen the jamb nut (5) on the bevel angle adjustment bolt (4) and adjust the bolt (4) in or out to increase or decrease the bevel angle with a 10 mm wrench.
4. Tilt the cutting arm to the left to 45° bevel and recheck for alignment.
5. Repeat steps 1 through 4 until the blade is at 45° to the miter table.
6. Tighten bevel lock handle and jamb nut (5) when alignment is achieved.

Fig. N

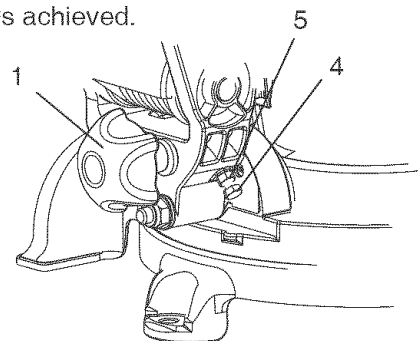

ALIGNING THE LASER BEAM

▲ WARNING

For your own safety, never connect the plug to power source outlet until all the adjustment steps are complete and you have read and understood the safety and operational instructions.

The laser beam must always be correctly aligned with the blade to ensure straight, even cutting.

Your tool is equipped with the Laser Trac® cutting guide using Class IIIa laser beams. The laser beam will enable to preview the saw blade path on the stock to be cut before starting the miter saw. This laser guide is powered by the transformed alternating current supply directly through the power lead. **The saw must be connected to the power source and the laser on/off switch must be turned on for the laser line to show.**

▲ WARNING

AVOID DIRECT EYE CONTACT

Laser radiated when laser guide is turned on. Avoid direct eye contact. Always un-plug the miter saw from power source before making any adjustments.

NOTE: All the adjustments for the operation of this machine have been completed at the factory. Due to normal wear and use, some occasional readjustments may be necessary.

A. Check Laser Beam Alignment.

1. Mark a 90° straight line across a board to serve as a "pattern line" to test laser alignment. Lay the board on the miter table.
2. Plug saw into outlet and turn on the laser beam and line it up with the pattern line.
3. Lower saw blade to pattern line and if blade is not flush with the pattern line, adjust as follows in procedures (B).

B. Adjusting the Angle of the Laser Trac® (Fig. N-2)

1. Turn the laser element (1) in the desired direction to adjust the laser angle. **NOTE:** Do not adjust the laser more than ¼ turn in either direction as this may damage the laser. There are two flat sides on the laser element where you can position an adjustable wrench for your adjustment.

C. Aligning The Laser Beam

1. Loosen only ½ turn at a time the three set screws (1).
2. Adjust laser by turning the left side set screw clockwise to shift the laser line to the right. To shift the laser line to the left, turn the right side set screws ½ turn at a time.
3. Once alignment of the laser is achieved, tighten only ½ turn at a time the three set screws

- (1). Start with the set screw on the left side of the laser assembly, then with the front set screw on the right side of the laser assembly.

Fig. N-1

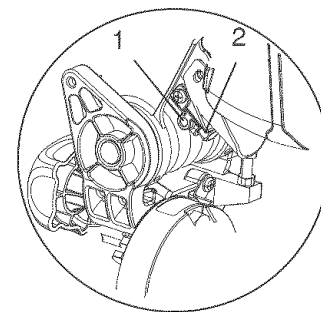
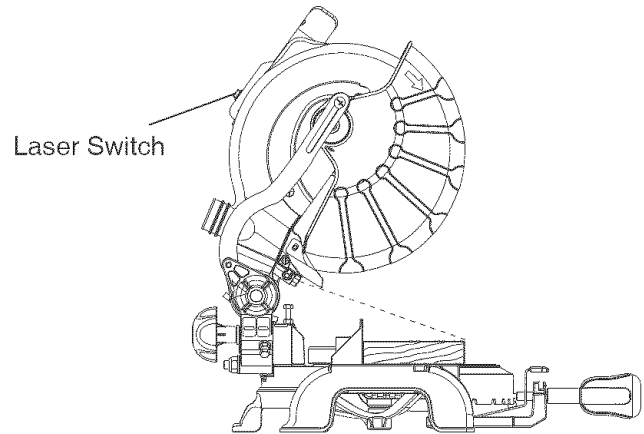

Left Side View

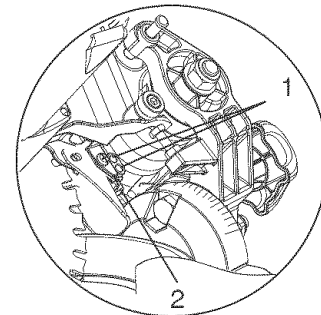

Right Side View

Fig. N-2

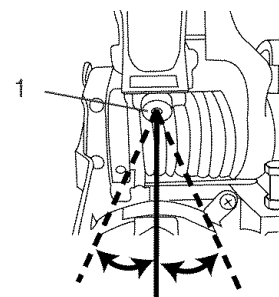

MOUNTING THE MITER SAW (FIG. O)

To avoid injury from unexpected saw movement:

- Before moving the saw, disconnect the power cord from the outlet, and lock the cutting arm in the lower position using the stop latch.

NOTE: The stop latch is for carrying or storing the tool. It is not to be used for holding the saw while cutting. Lower blade and press in stop latch to secure saw for transport or storage.

- Never carry the miter saw by the power cord or by the switch handle. Carrying the tool by the power cord could cause damage to the insulation or wire connections resulting in electric shock or fire.
- To avoid injury from flying debris, do not allow visitors to stand behind the saw.
- Place the saw on a firm, level work-surface where there is room for handling and properly supporting the workpiece.
- Support the saw on a level work surface.
- Bolt or clamp the saw to its support.

Place the saw in the desired location, either on a work bench or recommended leg set. The base of the saw has three mounting holes (1).

For stationary use, fasten the saw to a workbench.

For portable use, fasten the saw to a 3/4 in. piece of plywood. This mounting board can then be clamped to a secure surface.

Fig. O

Portable Use

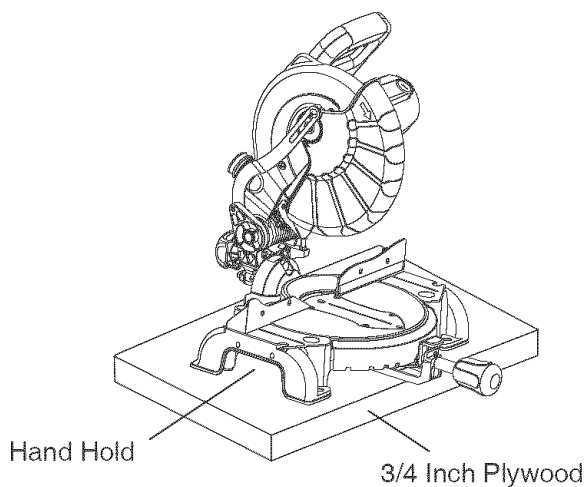

Stationary Use

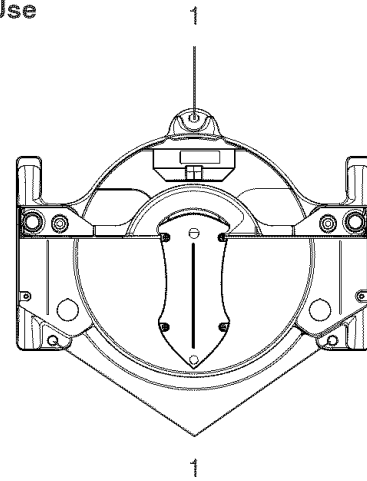

OPERATION

SAFETY INSTRUCTIONS FOR BASIC SAW OPERATION

BEFORE USING THE MITER SAW

WARNING

To avoid mistakes that could cause serious, permanent injury, do not plug the tool in until the following steps are completed:

- Completely assemble and adjust the saw, following the instructions. (ASSEMBLY AND ADJUSTMENTS)
- Learn the use and function of the ON/OFF switch, lock-off switch, upper and lower blade guards, stop latch, bevel lock handle, and cover plate screws.
- Review and understand all safety instructions and operating procedures in this Operator's Manual. (SAFETY & OPERATIONS)
- Review the MAINTENANCE and TROUBLESHOOTING GUIDE for your miter saw.
- To avoid injury or possible death from electrical shock:
Make sure your fingers do not touch the plug's metal prongs when plugging or unplugging your miter saw. (ELECTRICAL REQUIREMENTS AND SAFETY)

BEFORE EACH USE INSPECT YOUR SAW.

- Disconnect the miter saw. To avoid injury from accidental starting, unplug the saw before any adjustments, including set-up and blade changes.
- Compare the direction of rotation arrow on the guard to the direction arrow on the blade. The blade teeth should always point downward at the front of the saw.
- Tighten the arbor bolt.
- Tighten the cover plate screw.
- Check for damaged parts. Check for:
 - Alignment of moving parts
 - Damaged electric cords
 - Binding of moving parts
 - Mounting holes
 - Function of arm return spring and lower guard:
Push the cutting arm all the way down, then let it rise until it stops. The lower guard should fully close. Follow instructions in TROUBLESHOOTING GUIDE for adjustment if necessary.
 - Other conditions that may affect the way the miter saw works.
- Keep all guards in place, in working order and proper adjustment. If any part of this miter saw

is missing, bent damaged or broken in any way, or any electrical parts don't work, turn the saw off and unplug it. Replace damaged, missing, or defective parts before using the saw again.

- Maintain tools with care. Keep the miter saw clean for best and safest performance. Follow instructions for lubricating. Don't put lubricants on the blade while it's spinning.
- Remove adjusting wrench from the tool before turning it on.
- To avoid injury from jams, slips, or thrown pieces:

USE ONLY RECOMMENDED ACCESSORIES

- Consult the ACCESSORIES and ATTACHMENTS section of this Operators Manual for recommended accessories. Follow the instructions that come with the accessory. The use of improper accessories may cause risk of injury to persons.
- Choose the correct 10 inch diameter blade for the material and the type of cutting you plan to do. Do not use thin kerf blades.
- Make sure the blade is sharp, undamaged and properly aligned. With the saw unplugged, push the cutting arm all the way down. Manually spin the blade and check for clearance. Tilt the power-head to a 45° bevel and repeat the test.
- Make sure the blade and arbor collars are clean.
- Make sure all clamps and locks are tight and there is no excessive play in any parts.

KEEP YOUR WORK AREA CLEAN

Cluttered areas and benches invite accidents.

WARNING

To avoid burns or other fire damage, never use the miter saw near flammable liquids, vapors, or gases.

- Plan ahead to protect your eyes, hands, face and ears.
- Know your miter saw.
Read and understand the Operator's Manual and labels affixed to the tool. Learn its application and limitations as well as the specific potential hazards peculiar to this tool. To avoid injury from accidental contact with moving parts, don't do layout, assembly, or setup work on the miter saw while any parts are moving.
- Avoid accidental starting
Make sure the trigger switch is disengaged before plugging the miter saw into a power outlet.

PLAN YOUR WORK

- Use the right tool. Don't force a tool or attachment to do a job it was not designed to do. Use a different tool for any workpiece that can't be held in a solidly braced, fixed position.

CAUTION: This machine is not designed for cutting masonry, masonry products, ferrous metals (steel, iron, and iron-based metals.) Use this miter saw to cut only wood, wood-like products, or non-ferrous metals. Other material may shatter, bind the blade, or create other dangers. Remove all nails that may be in the workpiece to prevent sparking that could cause a fire. Remove dust bag when cutting non-ferrous metals.

DRESS FOR SAFETY

Any power tool can throw foreign objects into the eyes. This can result in permanent eye damage. Everyday eyeglasses have only impact resistant lenses and are not safety glasses. Glasses or goggles not in compliance with ANSI Z87.1 could seriously injure you when they break.

- Do not wear loose clothing, gloves, neckties or jewelry (rings, watches). They can get caught and draw you into moving parts.
- Wear non-slip footwear.
- Tie back long hair.
- Roll long sleeves above the elbow.
- Noise levels vary widely. To avoid possible hearing damage, wear ear plugs when using any miter saw.
- For dusty operations, wear a dust mask along with safety goggles.

INSPECT YOUR WORKPIECE

Make sure there are no nails or foreign objects in the part of the workpiece being cut.

Plan your work to avoid small pieces that may bind, or that are too small to clamp and get a solid grasp on.

Plan the way you will grasp the workpiece from start to finish. Avoid awkward operations and hand positions. A sudden slip could cause your fingers or hand to move into the blade.

DO NOT OVER-REACH

Keep good footing and balance. Keep your face and body to one side, out of the line of a possible kickback. NEVER stand in the line of the blade.

Never cut freehand:

- Brace your workpiece firmly against the fence and table stop so it will not rock or twist during the cut.
- Make sure there is no debris between the workpiece and the table or fence.

- Make sure there are no gaps between the workpiece, fence and table that will let the workpiece shift after it is cut.
- Keep the cut off piece free to move sideways after it is cut off. Otherwise, it could get wedged against the blade and thrown violently.
- Only the workpiece should be on the saws table.
- Secure work. Use clamps or a vise to help hold the work when it's practical.

USE EXTRA CAUTION WITH LARGE OR ODD SHAPED WORKPIECES.

- Use extra supports (tables, sawhorses, blocks, etc.) for workpieces large enough to tip.
- Never use another person as a substitute for a table extension, or as an additional support for a workpiece that is longer or wider than the basic miter saw table, or to help feed, support, or pull the workpiece.
- Do not use this saw to cut small pieces. If the workpiece being cut would cause your hand or fingers to be within 6-3/4 inches of the saw blade the workpiece is too small. Keep hands and fingers out of the "no hands zone" area marked on the saws table.
- When cutting odd shaped workpieces, plan your work so it will not bind in the blade and cause possible injury. Molding, for example, must lie flat or be held by a fixture or jig that will not let it move when cut.
- Properly support round material such as dowel rods, or tubing, which have a tendency to roll when cut, causing the blade to "bite".

WARNING

To avoid injury, follow all applicable safety instructions, when cutting non-ferrous metals:

- Use only saw blades specifically recommended for non-ferrous metal cutting.
- Do not cut metal workpieces that must be hand held. Clamp workpieces securely.
- Cut non-ferrous metals only if you are under the supervision of an experienced person and the dust bag has been removed from the saw.

WHEN SAW IS RUNNING

WARNING

Do not allow familiarity from frequent use of your miter saw to result in a careless mistake. A careless fraction of a second is enough to cause a severe injury.

Before cutting, if the saw makes an unfamiliar noise or vibrates, stop immediately. Turn the saw OFF. Unplug the saw. Do not restart until finding and correcting the problem.

BODY AND HAND POSITION (FIG. P)

- Never place hands near the cutting area. Proper positioning of your body and hands when operating the miter saw will make cutting easier and safer. Place hand at least 6-3/4 in. away from the path of the blade, out of the “No-Hands Zone.” Hold workpiece firmly against the fence to prevent movement toward the blade. Before making a cut, with the power switch in the OFF position bring the saw blade down to the workpiece to see the cutting path of the blade.
 - Press in lock-off switch in trigger switch handle.
 - Squeeze trigger switch to start saw.
 - Lower blade into workpiece.
- Keep children away. Keep all visitors a safe distance from the miter saw. Make sure bystanders are clear of the miter saw and workpiece.
- Don't force tool. It will do the job better and safer at its designed rate. Feed the saw into the workpiece slowly with a firm downward motion.
- Before freeing jammed material.
- Release Trigger Switch.
- Unplug the miter saw.
- Wait for all moving parts to stop.
- After finishing a cut:
 - Holding the cutting arm in the down position.
 - Release the switch, and wait for all moving parts to stop before moving your hands and before raising the cutting arm.
 - If the blade doesn't stop within 6 seconds, unplug the saw and follow the instructions in TROUBLESHOOTING GUIDE section for adjusting the blade brake before using the saw again.
- Release the trigger switch, and wait for all moving parts to stop before moving your hands and raising cutting arm.

Fig. P

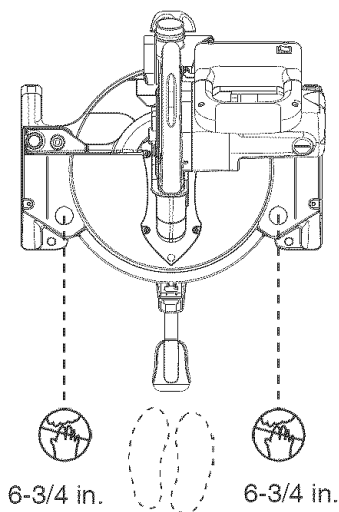

TURNING SAW ON (FIG. Q)

WARNING

Make the switch child-proof. Insert a padlock through the hole (2) in the trigger switch and lock it. This will prevent children and other unauthorized users from engaging the trigger switch ON.

This miter saw is equipped with an ON/OFF trigger switch (1). When the trigger switch is squeezed, the miter saw will be turned on.

Fig. Q

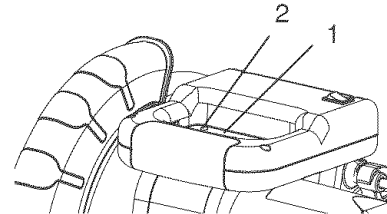

BEFORE LEAVING THE SAW

- Never leave tool running unattended. Turn power OFF. Wait for all moving parts to stop.
- Make workshop child-proof. Lock the shop. Disconnect master switches. Store tool away from children and other unqualified users.

MITER CUT (FIG. R)

1. When a miter cut is required, unlock the miter table by turning the miter handle (1) counterclockwise.
2. While holding the miter handle, press down on the positive stop locking lever (2) to disengage the positive stop locking lever.
3. Rotate the miter table to the right or left with the miter handle.
4. When the table is in the desired position as shown on the miter scale (3), release the positive stop locking lever handle and tighten the miter handle. The table is now locked at the desired angle. Positive stops are provided at 0°, 15°, 22.5°, 31.6° and 45°.

IMPORTANT: ALWAYS TIGHTEN the miter table lock handle before cutting.

Fig. R

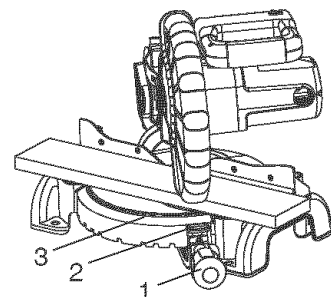

BEVEL CUT (FIG. S)

1. When a bevel cut is required, loosen the bevel lock handle (1).
2. Tilt the cutting head to the desired angle as shown on the bevel scale (2). The blade can be positioned at any angle, from a 90° straight cut (0° on the scale) to a 45° left bevel.
3. Tighten the bevel lock handle (1) to lock the cutting head in position.

Fig. S

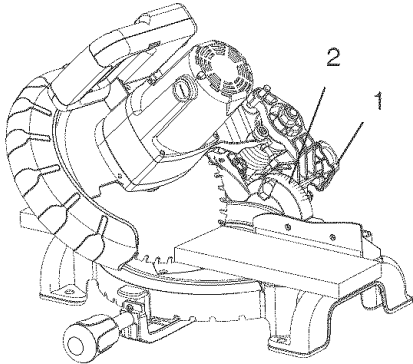

CUTTING BOWED MATERIAL (FIG. U)

A bowed workpiece must be positioned against the fence and secured with a clamping device before cutting. Do not position workpiece incorrectly or try to cut the workpiece without the support of the fence. This will cause the blade to bind and could result in personal injury.

Fig. U

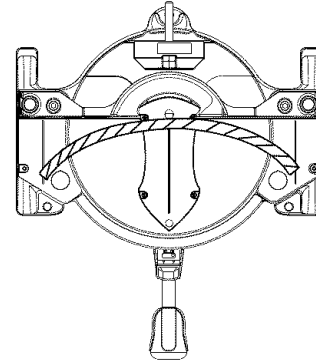

COMPOUND CUT (FIG. T)

A compound cut is the combination of a miter and a bevel cut simultaneously.

1. Loosen the bevel lock handle (1) and position the cutting head at the desired bevel position. Lock the bevel lock handle.
2. Loosen the miter table lock handle (2). Press down the positive stop locking lever (3) and position the table at the desired angle. Release the positive stop locking lever and lock the miter handle.

Fig. T

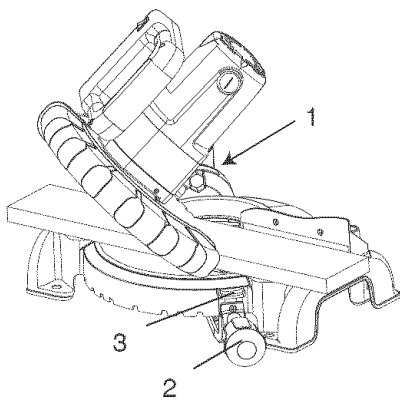

WORKPIECE SUPPORT (FIG. V)

Long pieces need extra support. The support should be placed under the workpiece. Keep your hand holding the workpiece positioned 6-3/4 inches or more away from the blade. The support must let the workpiece lay flat on the work table during the cutting operation. **NOTE:** When mounted on a flat surface, the miter saw table is 3-1/4 inches high.

Fig. V

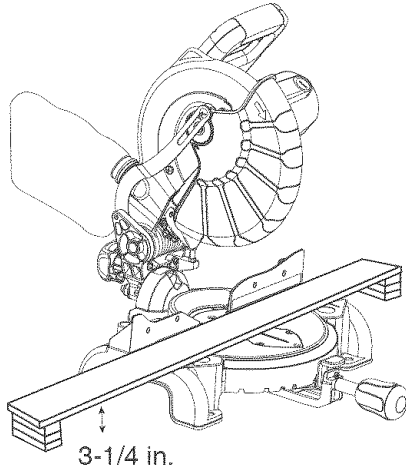
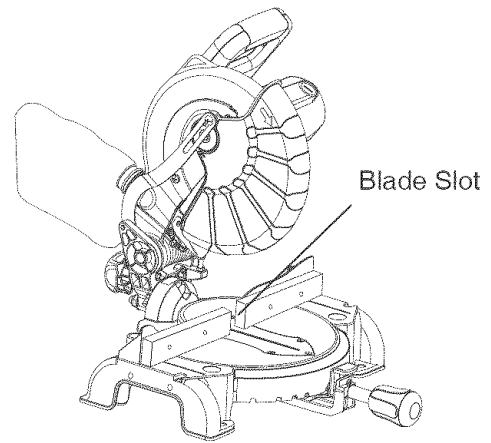

Fig. W



Cutting capacity with auxiliary fence	
Crosscut	3-1/2 in. x 3-1/2 in.
Miter 45° R & L	3-1/2 in. x 2 in.
Bevel 45° L	2 in. x 3-1/2 in.
Compound 45° L, 45° R & L	2 in. x 2 in.

AUXILIARY WOOD FENCE (FIG. W)

When making multiple or repetitive cuts that result in cut-off pieces of one inch or less, it is possible for the saw blade to catch the cut-off piece and throw it out of the saw or into the blade guard and housing, possibly causing damage or injury. To minimize this, an auxiliary wood fence can be mounted to your saw. Holes are provided in the saw fence to attach an auxiliary wood fence. This fence is constructed of straight auxiliary wood approximately 3/4 inch thick by 2-1/2 inches high by 16-1/8 inches long.

Attach the wood fence securely and make a full depth cut to make a blade slot. Check for interference between the wood fence and the lower blade guard. Adjust if necessary. **NOTE:** This auxiliary fence is used only with the saw blade in the 0° bevel position (90° to the table). The auxiliary wood fence must be removed when bevel cutting.

CUTTING A DIMENSIONAL 4x4 WITH ONE CUT

(Fig. X)

A dimensional 4x4 workpiece (3-1/2 in. x 3-1/2 in.) may be cut in half with one cut by attaching an auxiliary wood fence of 3/4 inch thick. See "AUXILIARY WOOD FENCE" above.

Fig. X

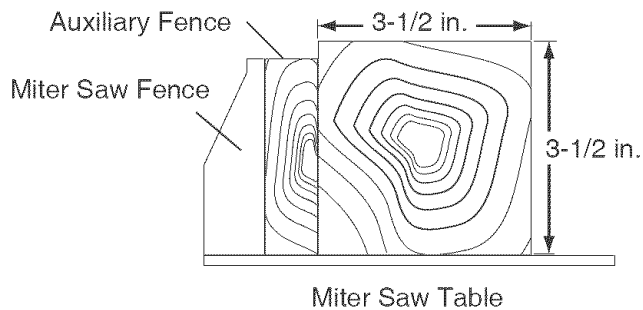
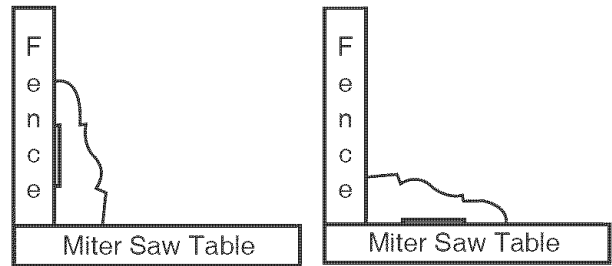

Fig. Z



Miter at 45°, bevel at 0° Miter at 0°, bevel at 45°

NOTE: Always perform a dry run cut so you can determine if the operation being attempted is possible before power is applied to the saw.

VERTICAL MITER CUTTING (FIG. Y)

To make a miter cut in a 2x4 workpiece (1-1/2 in. x 3-1/2 in.) in the vertical position a spacer such as the auxiliary wood fence described in the "AUXILIARY WOOD FENCE" section is required.

Fig. Y

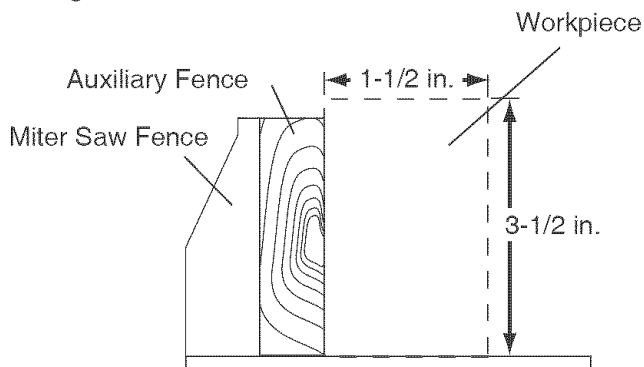

CUTTING BASE MOLDING (FIG. Z)

Base moldings and many other moldings can be cut on a compound miter saw. The setup of the saw depends on molding characteristics and application, as shown. Perform practice cuts on scrap material to achieve best results:

1. Always make sure moldings rest firmly against fence and table. Use hold-down or C-clamps, whenever possible, and place tape on the area being clamped to avoid marks.
2. Reduce splintering by taping the cut area prior to making cut. Mark cut line directly on the tape.
3. Splintering typically happens due to wrong blade application and thinness of the material.

CUTTING CROWN MOLDING (FIG. AA,BB)

NOTE: The chart below references a compound cut for crown molding ONLY WHEN THE ANGLE BETWEEN THE WALLS EQUALS EXACTLY 90°.

Your compound miter saw is suited for the difficult task of cutting crown molding. To fit properly, crown molding must be compound-mitered with extreme accuracy. The two surfaces on a piece of crown molding that fit flat against the ceiling and wall are at angles that, when added together equal exactly 90°.

Most crown molding has a top rear angle (the section that fits flat against the ceiling) of 52° and a bottom rear angle (the section that fits flat against the wall) of 38°.

In order to accurately cut crown molding for a 90° inside or outside corner, lay the molding with its broad back surface flat on the saw table.

When setting the bevel and miter angles for compound miters, remember that the settings are interdependent; changing one changes the other, as well. Also keep in mind that the angles from crown molding are very easy for these angles to shift slightly, all settings should be tested on scrap molding.

Bevel/Miter Settings

NOTE: The chart below references a compound cut for crown molding ONLY WHEN THE ANGLE BETWEEN THE WALLS EQUALS EXACTLY 90°.

KEY	BEVEL SETTING	Miter SETTING	TYPE OF CUT
Inside corner-Left side			
IL	33.9°	31.6° Right	1. Position top of molding against fence. 2. Miter table set at RIGHT 31.6°. 3. LEFT side is finished piece.
Inside corner-Right side			
IR	33.9°	31.6° Left	1. Position bottom of molding against fence. 2. Miter table set at LEFT 31.6°. 3. LEFT side is finished piece.
Outside corner-Left side			
OL	33.9°	31.6° Left	1. Position bottom of molding against fence. 2. Miter table set at LEFT 31.6°. 3. RIGHT side is finished piece.
Outside corner-Right side			
OR	33.9°	31.6° Right	1. Position top of molding against fence. 2. Miter table set at RIGHT 31.6°. 3. RIGHT side is finished piece.

Fig. AA

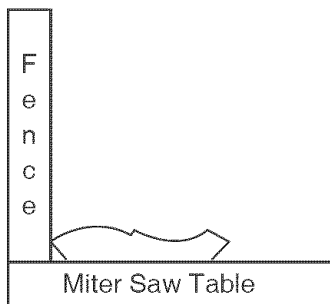
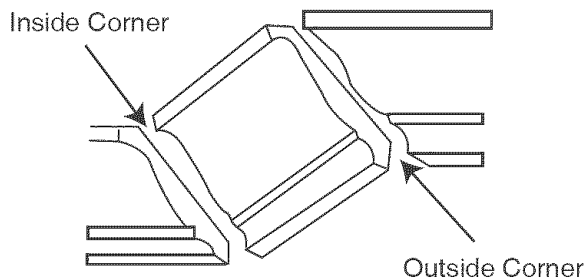

Fig. BB

Settings for standard crown molding lying flat on compound miter saw table



Compound Cut Crown Moldings

MAINTENANCE

MAINTENANCE

▲ DANGER

Never put lubricants on the blade while it is spinning.

▲ WARNING

To avoid fire or toxic reaction, never use gasoline, naphtha acetone, lacquer thinner or similar highly volatile solvents to clean the miter saw.

▲ WARNING

To avoid injury from unexpected starting or electrical shock, unplug the power cord before working on the saw.

▲ WARNING

For your safety, this saw is double-insulated. To avoid electrical shock, fire or injury, use only parts identical to those identified in the parts list. Reassemble exactly as the original assembly to avoid electrical shock.

REPLACING CARBON BRUSHES (FIG. CC)

Replace both carbon brushes when either has less than 1/4in. length of carbon remaining, or if the spring or wire is damaged or burned. To inspect or replace brushes, first unplug the saw. Then remove the black plastic cap (1) on the side of the motor (2). Remove the cap cautiously, because it is springloaded. Then pull out the brush and replace. Replace for the other side. To reassemble reverse the procedure. The ears on the metal end of the assembly go in the same hole the carbon part fits into. Tighten the cap snugly, but do not overtighten.

NOTE: To reinstall the same brushes, first make sure the brushes go back in the way they came out. This will avoid a break-in period that reduces motor performance and increases wear.

Fig. CC

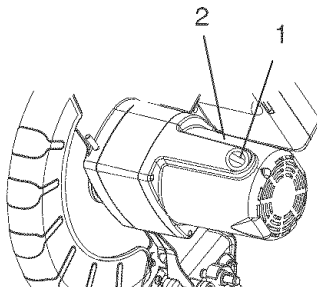

LOWER BLADE GUARD

Do not use the saw without the lower blade guard. The lower blade guard is attached to the saw for your

protection. Should the lower guard become damaged, do not use the saw until the damaged guard has been replaced. Develop a regular check to make sure the lower guard is working properly. Clean the lower guard of any dust or buildup with a damp cloth.

CAUTION: Do not use solvents on the guard. They could make the plastic “cloudy” and brittle.

▲ WARNING

When cleaning the lower guard, unplug the saw from the power source receptacle to avoid unexpected startup.

SAWDUST

Periodically, sawdust will accumulate under the work table and base. Frequently blow out or vacuum up the sawdust.

▲ WARNING

If blowing sawdust, wear proper eye protection to keep debris from blowing into eyes.

LUBRICATION

All the motor bearings in this tool are lubricated with a sufficient amount of high grade lubricant for the life of the unit under normal operating conditions; therefore, no further lubrication is required.

Lubricate the following as necessary:

Chop pivot: Apply light machine oil to points indicated in illustration.

Central pivot of plastic guard: Use light household oil (sewing machine oil) on metal-to-metal or metal-to-plastic guard contact areas as required for smooth, quiet operation. Avoid excessive oil, to which sawdust will cling.

Fig. DD

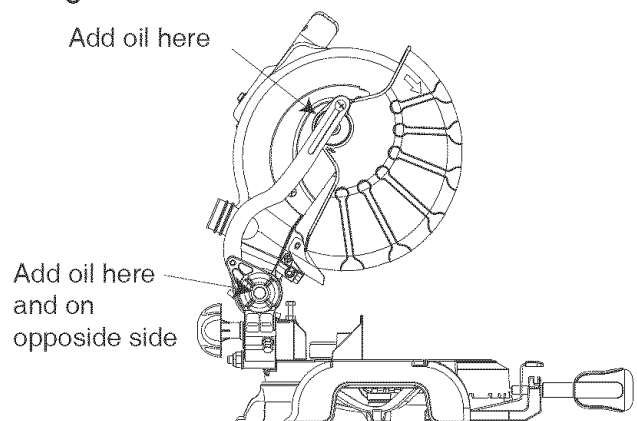

TROUBLESHOOTING GUIDE

WARNING

To avoid injury from accidental starting, always turn switch OFF and unplug the tool before moving, replacing the blade or making adjustments.

Consult your Sears Service Centre if for any reason the motor will not run.

TROUBLESHOOTING GUIDE - MOTOR

PROBLEM	PROBLEM CAUSE	SUGGESTED CORRECTIVE ACTION
Brake does not stop blade within 6 seconds.	<ol style="list-style-type: none"> 1. Motor brushes not sealed or lightly sticking. 2. Motor brake overheated from use of defective or wrong size blade or rapid ON/OFF cycling. 3. Arbor bolt loose. 4. Other. 	<ol style="list-style-type: none"> 1. Inspect / clean / replace brushes. See MAINTENANCE section. 2. Use a recommended blade. Let cool down. 3. Retighten. 4. Sears Service Centre.
Motor does not start	<ol style="list-style-type: none"> 1. Fuse Blown 2. Brush worn. 3. Other. 	<ol style="list-style-type: none"> 1. Check and use 15-Amp time delay fuse, or circuit breaker. 2. Replace brushes. See MAINTENANCE section. 3. Sears Service Centre.
Brush spark when switch released.	<ol style="list-style-type: none"> 1. Brush worn. 2. Other. 	<ol style="list-style-type: none"> 1. Replace Brushes. 2. See Sears Service Centre.

TROUBLESHOOTING GUIDE - SAW OPERATION

PROBLEM	PROBLEM CAUSE	SUGGESTED CORRECTIVE ACTION
Blade hits table.	<ol style="list-style-type: none"> 1. Misalignment. 	<ol style="list-style-type: none"> 1. See ADJUSTMENT section.
Angle of cut not accurate. Can't adjust miter.	<ol style="list-style-type: none"> 1. Miter table unlocked. 2. Sawdust under table. 	<ol style="list-style-type: none"> 1. See OPERATION Section. 2. Vacuum or blow out dust, WEAR EYE PROTECTION.
Cutting arm wobbles.	<ol style="list-style-type: none"> 1. Loose pivot points. 	<ol style="list-style-type: none"> 1. See ADJUSTMENT Section.
Cutting arm won't fully raise, or blade guard won't fully close.	<ol style="list-style-type: none"> 1. Part failure. 2. Pivot spring not replaced properly after service. 3. Sawdust build-up. 	<ol style="list-style-type: none"> 1. Sears Service Centre. 2. Sears Service Centre. 3. Clean and lubricate moving parts.
Blade binds, jams, burns wood.	<ol style="list-style-type: none"> 1. Improper operation. 2. Dull blade. 3. Improper blade size. 4. Warped blade. 	<ol style="list-style-type: none"> 1. See BASIC SAW OPERATION section. 2. Replace or sharpen blade. 3. Replace with 10in. diameter blade. 4. Replace blade.
Saw vibrates or shakes.	<ol style="list-style-type: none"> 1. Saw blade not round. 2. Saw blade damaged. 3. Saw blade loose. 4. Other. 	<ol style="list-style-type: none"> 1. Replace blade. 2. Replace blade. 3. Tighten arbor bolt. 4. Sears Service Centre.

PARTS LIST

10 in. COMPOUND MITER SAW

MODEL NO. 137.212290

WARNING

When servicing use only CRAFTSMAN replacement parts. Use of any other parts may create a HAZARD or cause product damage. Any attempt to repair or replace electrical parts on this Miter Saw may create a HAZARD unless repair is done by a qualified service technician. Repair service is available at your nearest Sears Service Centre. To purchase replacement parts, call 1-800-469-4663.

PARTS LIST FOR SAW SCHEMATIC

I.D. NO	DESCRIPTION	SIZE	QTY	I.D. NO	DESCRIPTION	SIZE	QTY
081A	PLASTIC SLEEVE		1	OKR0	NUT	M12*1.75 T=12	1
0824	PIVOT SHAFT		1	OKUY	TERMINAL		2
0828	ROTATION SLIDE PLATE		1	OLS9	ROCKER SWITCH		1
0831	SHAFT SLEEVE		1	OLU2	LIMIT SWITCH		1
083S	TRIGGER		1	OQQ1	GUARD-CORD		1
083Z	CORD CLAMP		1	OS1S	COLLAR		1
085N	COMPRESSION SPRING	L=25 D=Φ8 DW=0.8 N=10	1	128Q	WAVE WASHER		1
0CES	COMPRESSION SPRING		1	23NF	ARBOR COLLAR		2
0CPD	CENTER SHAFT		1	26LU	WARNING LABEL		1
0CV5	DUST BAG ASS'Y		1	290M	CAUTION LABEL		1
0D7X	SHAFT		1	2948	WARNING LABEL		2
0D87	TORSION SPRING	D=Φ50 N=8 WD=Φ6	1	2BA4	TABLE	#AW	1
0D99	SHIM		1	2BK3	ANGLE REGULATOR	#AW	1
0D9B	ANCHOR BLOCK		1	2BK8	TABLE INSERT		1
0DHT	SPRING GUARD	WD=Φ1.3	1	2BKK	CABLE SHIELD		1
0DVJ	HEX. WRENCH		1	2BNF	LASER PLUNGER HOUSING		1
0J4F	FLAT WASHER	Φ8X16-2.5	1	2BP5	NEEDLE POINTER		1
0J4J	FLAT WASHER	Φ10X20-2	1	2BPR	CABLE SHIELD		1
0J4R	FLAT WASHER	Φ10*20-3	1	2BPS	HANDLE		1
0J7R	FLAT WASHER	1/2*1-3/64	1	2BPT	COIL SPRING		1
0JA6	WASHER	Φ5	2	2BPV	CUTTER SHAFT GUARD		1
0JB0	WAVE WASHER	WW-8	1	2BPW	NEEDLE POINTER	#23	1
0JET	E-RING		1	2BPX	ARM-MITER	#AW	1
0JMM	O-RING		1	2BX0	CR.RE. PAN HD. SCREW & WASHER	M5*0.8-80	3
0JPE	HEX. HD. BOLT	M6*1.0-20	2	2BX7	SLOTTED SET SCREW	M6*1.0-8	3
0JPG	HEX. HD. BOLT	M6*1.0-30	1	2BXF	PLUNGER HOUSING ASS'Y		1
0JUK	HEX. SOC. HD. CAP BOLT	M6*1.0-16	1	2C0F	CONTROLLER ASS'Y		1
0JZF	HEX. SOC. SET SCREW	M6*1.0-10	3	2C1A	POWER CABLE		1
0JZN	ARBOR BOLT	M8*1.25-20	1	2C82	HEX. HD. BOLT	M10*1.5-80	1
OK0W	HEX. HD. SCREW AND WASHER	M6*1.0-25	2	2C88	BLADE		1
OK2N	HEX SOC. HD. CAP SCREW	M8*1.25-25	2	2C8D	CLEVIS PIN		1
OK42	CR.RE. PAN HD. SCREW & WASHER	M6*1.0-30	2	2C8E	CHIP PLATE		1
OK5C	CR. RE. COUNT HD. SCREW	M6*1.0-16	1	2CBW	BASE		1
OK7F	CR. RE. ROUND WASHER HD. SCREW	M5*0.8-8	2	2CBY	HANDLE		1
OK7X	CR. RE. TRUSS HD. ROUND NECK SCREW	M6X1.0-10	1	2CKJ	FENCE	#AW	1
OK7Z	CR. RE. TRUSS HD. ROUND NECK SCREW	M6*1.0-14	1	2CR7	ARM	#AW	1
OKA9	CR.RE. PAN HD. TAPPING SCREW	M3*24-10	1	2CS7	LOCKING HANDLE ASS'Y		1
OKB7	CR.RE. PAN HD. TAPPING SCREW	M4X18-16	2	2CS9	CLAMP HANDLE		1
OKBC	CR.RE. PAN HD. TAPPING SCREW	M5*16-25	1	2CSB	MOTOR ASS'Y		1
OKBD	CR.RE. PAN HD. TAPPING SCREW	M4X18-25	4	2CTE	LEAD WIRE ASS'Y		1
OKD6	CR. RE. PAN HD. SCREW	M4*0.7-8	4	2CU6	PC-GUARD		1
OKD7	CR. RE. PAN HD. SCREW	M4*0.7-10	4	2CYM	INSTRUCTIONS MANUAL		1
OKDH	CR. RE. PAN HD. SCREW	M5*0.8-8	3	2D47	LOCATOR PIN		1
OKDR	CR. RE. PAN HD. SCREW	M5*0.8-10	1	2D8M	LEVER		1
OKE1	CR. RE. PAN HD. SCREW	M6X1.0-10	1	2DAR	LABEL		1
OKL1	CR.RE. PAN HD. ROUND NECK SCREW	M6*1.0-12	1	2DAS	BRACKET-TILT		1
OKMS	HEX. NUT	M6*1.0 T=5	4	2DAT	SCALE		1
OKQX	NUT	M6*1.0 T=6	3	2DAV	TILTING SCALE		1
OKQY	LUCK NUT	M8*1.25 T=8	1	2DAW	TRADE-MARK LABEL		1
OKQZ	NUT	M10*1.5 T=10	1	2DCF	WARNING LABEL		1

10 in. COMPOUND MITER SAW

MODEL NO. 137.212290

SCHEMATIC FOR SAW

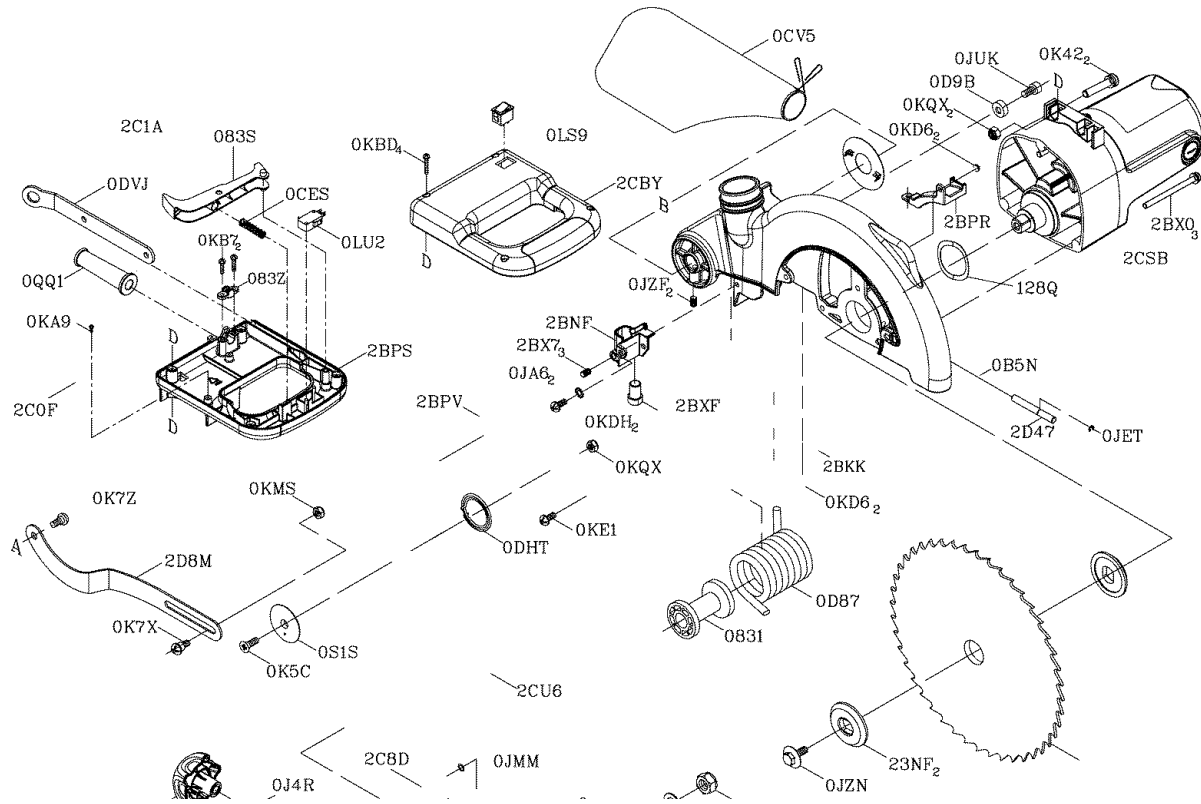

PARTS LIST AND SCHEMATIC FOR MOTOR

I.D. NO	Description	Size	QTY
0HVY	BALL BEARING	6204ZZ	1
0HX9	NEEDLE BEARING	HK-1010	1
0JX3	HEX. SOC. SET SCREW	M5*0.8-8	2
0KCN	CR.RE. PAN HEAD TAPPING & WASHER SCREW	M5*12-50	2
0QQS	BRUSH HOLDER ASS'Y		2
0QQT	BRUSH ASS'Y		2
0QR0	BRUSH COVER		2
2AKT	ARMATURE ASS'Y		1
2BPA	FIELD ASS'Y		1
2BPB	CUTTER SHAFT		1
2BPC	SPACER		1
2BPD	HELIX GEAR		1
2BPE	GEAR BOX		1
2BPF	FLOW GUIDE		1
2BPP	MOTOR COVER		1
2CVE	LEAD WIRE ASS'Y		1

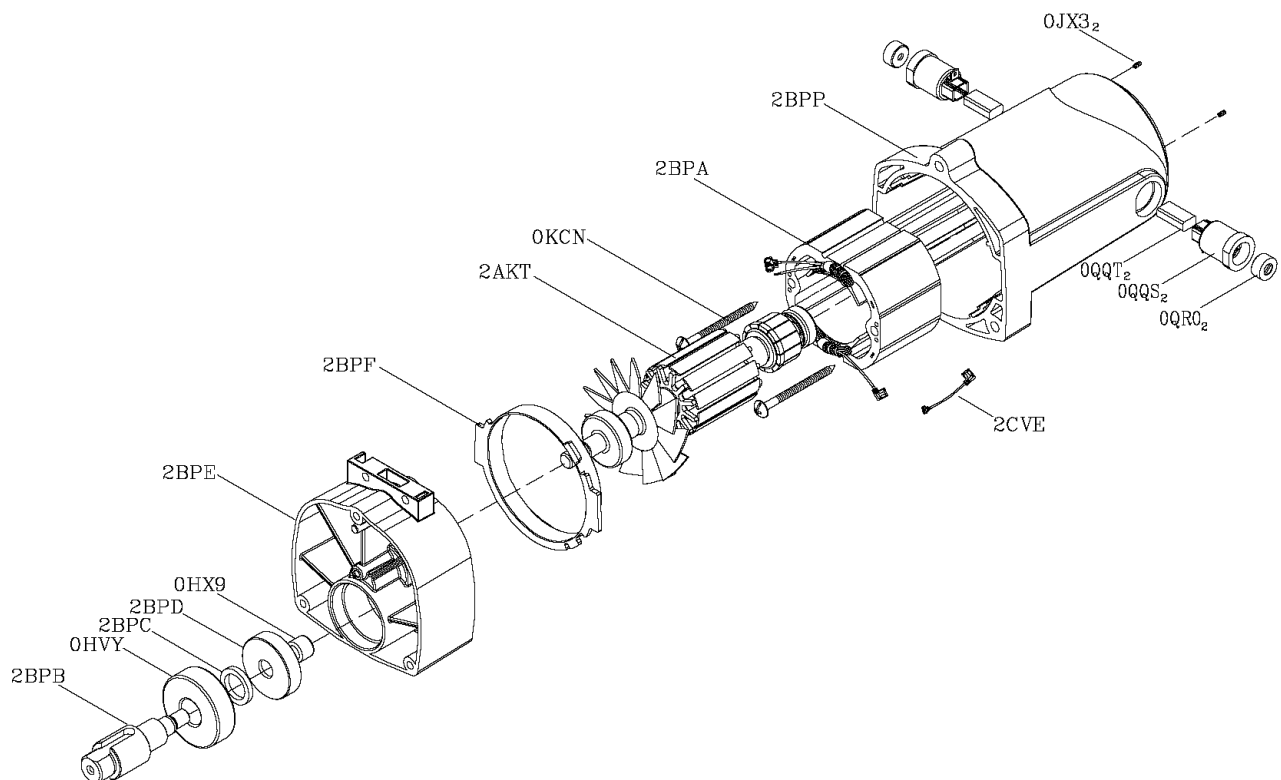

Get it fixed, at your home or ours!

Your Home

For repair – **in your home** – of all major brand appliances, lawn and garden equipment, or heating and cooling systems, **no matter who made it, no matter who sold it!**

For the replacement parts, accessories and Operator's Manuals that you need to do-it-yourself. For Sears professional installation of home appliances and items like garage door openers and water heaters.

1-800-4-MY-HOME® (1-800-469-4663)

Call anytime, day or night (U.S.A. and Canada)

www.sears.com

sears.ca

Our Home

For repair of carry-in items like vacuums, lawn equipment, and electronics, call or go on-line for the location of your nearest

Sears Parts & Repair Center.

1-800-488-1222

Call anytime, day or night (U.S.A. only)

www.sears.com

To purchase a protection agreement on a product serviced by Sears:

1-800-827-6655 (U.S.A.)

1-800-361-6665 (Canada)

Para pedir servicio de reparación a domicilio, y para ordenar piezas:

1-888-SU-HOGARSM

(1-888-784-6427)

Au Canada pour service en français:

1-800-LE-FOYER^{MD}

(1-800-533-6937)

sears.ca

SEARS

Free Manuals Download Website

<http://myh66.com>

<http://usermanuals.us>

<http://www.somanuals.com>

<http://www.4manuals.cc>

<http://www.manual-lib.com>

<http://www.404manual.com>

<http://www.luxmanual.com>

<http://aubethermostatmanual.com>

Golf course search by state

<http://golfingnear.com>

Email search by domain

<http://emailbydomain.com>

Auto manuals search

<http://auto.somanuals.com>

TV manuals search

<http://tv.somanuals.com>