

# Operator's Manual

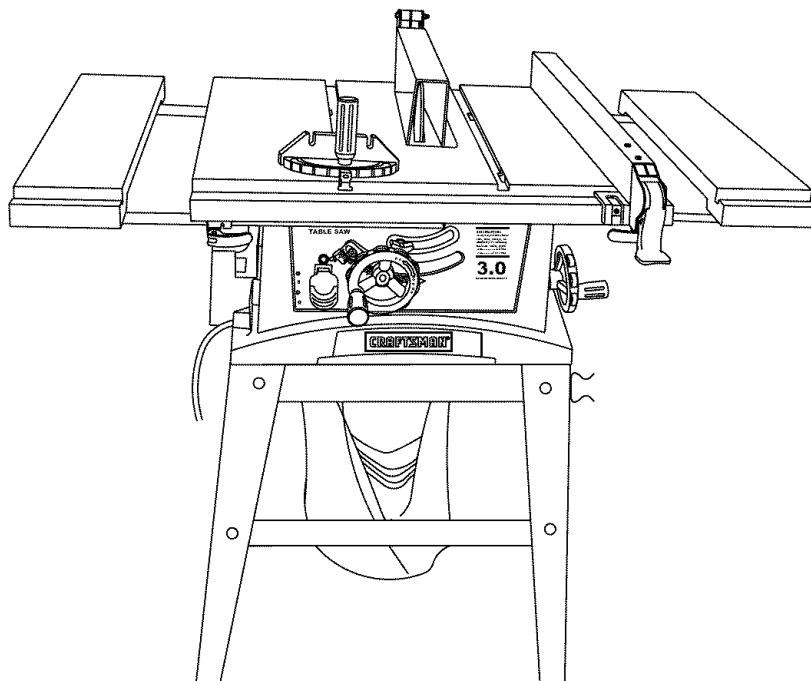

## 10 in. TABLE SAW Model No. 137.248840



### **CAUTION:**

Before using this Table Saw, read this manual and follow all its Safety Rules and Operating Instructions

- Safety Instructions
- Installation
- Operation
- Maintenance
- Parts List

**Customer Help Line**  
**1-800-843-1682**

Sears, Roebuck and Co., Hoffman Estates, IL 60179 USA

Visit our Craftsman website: [www.sears.com/craftsman](http://www.sears.com/craftsman)

Part No. 137248840001

# TABLE OF CONTENTS

SECTION	PAGE	SECTION	PAGE
Warranty .....	2	Know Your Table Saw .....	8
Product Specifications .....	2	Glossary of Terms .....	9
Power Tool Safety .....	3	Assembly and Adjustments .....	10
Table Saw Safety .....	4	Operation .....	17
Electrical Requirements and Safety .....	5	Maintenance .....	22
Accessories and Attachments .....	6	Troubleshooting Guide .....	23
Tools Needed for Assembly .....	6	Parts List .....	24
Carton Contents .....	6		

## WARRANTY

### ONE-YEAR FULL WARRANTY ON CRAFTSMAN TOOL

If this Craftsman tool fails due to a defect in material or workmanship within one year from the date of purchase, **CALL 1-800-4-MY-HOME® TO ARRANGE FOR FREE REPAIR.**

If this tool is used for commercial or rental purposes, this warranty will apply for only ninety days from the date of purchase. This warranty applies only while this tool is in the United States.

This warranty gives you specific legal rights, and you may also have other rights, which vary, from state to state.

**Sears, Roebuck & Co., Dept. 817 WA, Hoffman Estates, IL 60179**

#### WARNING

Some dust created by power sanding, sawing, grinding, drilling and other construction activities contains chemicals known to cause cancer, birth defects or other reproductive harm. Some examples of these chemicals are:

- Lead from lead-based paints
- Crystalline silica from bricks, cement and other masonry products
- Arsenic and chromium from chemically treated lumber

Your risk from these exposures varies, depending on how often you do this type of work. To reduce your exposure to these chemicals, work in a well ventilated area and work with approved safety equipment such as dust masks that are specially designed to filter out microscopic particles.

## PRODUCT SPECIFICATIONS

#### MOTOR

Type .....	Universal
Amps .....	15
Voltage .....	120
Hz .....	60
RPM (no load) .....	5000
Overload Protection .....	YES

#### SAW

Blade Size .....	10 in.
Arbor Size .....	5/8 in.
Rip Fence .....	YES
Miter Gauge .....	YES
Maximum Cut Depth @90° .....	3 in.
Maximum Cut Depth @45° .....	2-1/2 in.
Maximum Dado Cut Width .....	1/2 in.

#### WARNING

To avoid electrical hazards, fire hazards or damage to the tool, use proper circuit protection.

This tool is wired at the factory for 110-120 Volt operation. It must be connected to a 110-120 Volt / 15 Ampere time delay fuse or circuit breaker. To avoid shock or fire, replace power cord immediately if it is worn, cut or damaged in any way.



Before using your tool, it is critical that you read and understand these safety rules. Failure to follow these rules could result in serious injury to you or damage to the tool.

# POWER TOOL SAFETY

## **WARNING**

Before using your table saw, it is critical that you read and understand these safety rules. Failure to follow these rules could result in serious injury or damage to the table saw.

Good safety practices are a combination of common sense, staying alert and understanding how to use your power tool. To avoid mistakes that could cause serious injury, do not plug in your power tool until you have read and understood the following safety rules:

- 1. READ** and become familiar with the entire Operator's Manual. **LEARN** the tool's application, limitations and possible hazards.
-  **WARNING** Look for this symbol that identifies important safety precautions. It means **CAUTION!** Become alert, your safety is involved if you do not follow the safety instructions.
-  **DANGER** Look for this symbol that identifies important safety precautions. It means **CAUTION!** Become alert, your safety is involved if you do not follow the safety instructions.
- NEVER OPERATE THIS MACHINE WITHOUT THE SAFETY GUARD IN PLACE FOR ALL THROUGH-SAWING OPERATIONS.**
- DO NOT USE IN A DANGEROUS ENVIRONMENT** such as damp or wet locations or exposure to rain. Keep work area well lighted.
- DO NOT** use power tools in the presence of flammable liquids or gases.
- KEEP WORK AREA CLEAN.** Cluttered areas and benches invite accidents.
- KEEP CHILDREN AWAY.** All visitors should be kept at a safe distance from the work area.
- DO NOT FORCE THE TOOL.** It will do the job better and safer at the rate for which it was designed.
- USE THE RIGHT TOOL.** Do not force the tool or attachment to do a job for which it is not designed.
- WEAR PROPER APPAREL. DO NOT** wear loose clothing, gloves, neckties, rings, bracelets or other jewelry that may get caught in moving parts. Non-slip footwear is recommended. Wear protective hair covering to contain long hair.
- WEAR A FACE MASK OR DUST MASK.** Sawing, cutting and sanding operations produce dust.
- DISCONNECT TOOLS** before servicing and when changing accessories such as blades, cutters, etc.
- REDUCE THE RISK OF UNINTENTIONAL STARTING.** Make sure the switch is in the OFF position before plugging into the power supply.
- USE ONLY RECOMMENDED ACCESSORIES.** Consult the Operator's Manual for recommended accessories. The use of improper accessories may cause injury to you or damage to the tool.
- REMOVE ADJUSTING KEYS AND WRENCHES.** Form the habit of checking to see that keys and adjusting wrenches are removed from the tool before turning ON.
- NEVER LEAVE TOOL RUNNING UNATTENDED. TURN THE POWER "OFF".** Do not leave the tool before it comes to a complete stop.
- NEVER STAND ON TOOL.** Serious injury could occur if the tool is tipped or if the cutting tool is unintentionally contacted.
- DO NOT OVERREACH.** Keep proper footing and balance at all times.
- MAINTAIN TOOLS WITH CARE.** Keep tools sharp and clean for most efficient and safest performance. Follow instructions for lubricating and changing accessories.
- CHECK FOR DAMAGED OR LOOSE PARTS.** Before further use of the tool, a guard or other part that is damaged should be carefully checked to ensure it will operate properly and perform its intended function. Check for alignment of moving parts, binding of moving parts, loose mounting and any other conditions that may affect its safe operation. A guard or other part that is loose or damaged should be properly adjusted repaired or replaced.
- MAKE WORKSHOP CHILD PROOF** with padlocks, master switches or by removing starter keys.
- DO NOT** operate the tool if you are under the influence of any drugs, alcohol or medication that could impair your ability to use the tool safely.
- USE A DUST COLLECTION SYSTEM** wherever possible. Dust generated from certain materials can be hazardous to your health and in some cases, a fire hazard. Always operate the power tool in a well-ventilated area with adequate dust removal.
- ALWAYS WEAR EYE PROTECTION.** Any power tool can throw foreign objects into your eyes which could cause permanent eye damage. **ALWAYS** wear safety goggles (not glasses) that comply with ANSI safety standard Z87.1. Everyday glasses have only impact resistant lenses. They **ARE NOT** safety glasses. Safety Goggles are available at Sears. **NOTE:** Glasses or goggles not in compliance with ANSI Z87.1 could cause serious injury when they break.
- DIRECTION OF FEED.** Feed work into a blade or cutter against the direction of rotation of the blade or cutter only.
- DO NOT AUTHORIZE ADDITIONAL USERS** to operate this power tool without the accompanying operators manual for which the user must read and understand.

# TABLE SAW SAFETY

- 1. ALWAYS USE SAW BLADE GUARD**, splitter and anti-kickback pawls for every operation for which they can be used, including through-sawing. Through-sawing operations are those in which the blade cuts completely through the workpiece when ripping or cross-cutting.
- 2. ALWAYS HOLD WORK FIRMLY** against the miter gauge or rip fence.
- 3. USE A PUSH STICK** when required. Always use a push stick when ripping narrow stock. Refer to ripping instructions in this Operator's Manual where the push stick is covered in detail. A pattern for making your own push stick is included on page 28.
- 4. NEVER PERFORM ANY OPERATION "FREE HAND"**, which means using only your hands to support or guide the workpiece. Always use either the fence or the miter gauge to position and guide the work.  

**FREEHAND CUTTING IS THE MAJOR CAUSE OF KICK-BACK & FINGER/HAND AMPUTATIONS.**
- 5. NEVER STAND** or have any part of your body in line with the path of the saw blade. Keep your hands out of the saw blade path.
- 6. NEVER REACH** behind or over the cutting tool for any reason.
- 7. NEVER** use a rip fence when cross cutting.
- 8. DO NOT USE** a molding head with this saw.
- 9. FEED WORK INTO THE BLADE** against the direction of rotation only.
- 10. NEVER** use the rip fence as a cut-off gauge when cross-cutting.
- 11. NEVER ATTEMPT TO FREE A STALLED SAW BLADE** without first turning the saw OFF. Turn power switch OFF and disconnect the plug from the power source immediately to prevent motor damage & before removing material.
- 12. PROVIDE ADEQUATE SUPPORT** to the rear and the sides of the saw table for long or wide workpieces.
- 13. AVOID KICKBACKS** (work thrown back towards you) by keeping the blade sharp, the rip fence parallel to the saw blade and by keeping the splitter, anti-kickback pawls and guards in place and functioning. Do not release work before it has passed all the way past the saw blade and is off the table. Do not rip work that is twisted, warped or does not have a straight edge to guide it along the fence.
- 14. AVOID AWKWARD OPERATIONS** and hand positions where a sudden slip could cause your hand to move into the saw blade.
- 15. NEVER USE SOLVENTS** to clean plastic parts. Solvents could possibly dissolve or otherwise damage the material. Only a soft damp cloth should be used to clean plastic parts.
- 16. MOUNT** your table saw on a bench or stand before performing any cutting operations. Refer to **ASSEMBLY AND ADJUSTMENTS** on page 10.
- 17. NEVER CUT METALS** or materials which may make hazardous dust.
- 18. ALWAYS USE IN WELL-VENTILATED AREA.** Remove sawdust frequently. Clean out sawdust from the interior of the saw to prevent a potential fire hazard. Attach a vacuum to the dust port for additional sawdust removal.
- 19. NEVER LEAVE THE SAW** running unattended. Do not leave the saw until it comes to a complete stop.
- 20. FOR** proper operation follow the instructions in this Operator's Manual. Failure to provide sawdust fall-through and removal hole will allow sawdust to build up in the motor area resulting in a fire hazard and potential motor damage (see page 11 for details).
- 21. DO NOT AUTHORIZE ADDITIONAL USERS** to operate this power tool without the accompanying operators manual for which the user must read and understand.
- 22. THE REAR OF THE TABLE INSERT MUST BE FLUSH TO THE TABLE** during all sawing operations. A rubber adjusting spacer is provided under the rear of the insert for this purpose.
- 23. DO NOT USE A DADO BLADE LARGER THAN** 6 inches in diameter and ½ inch in width. Only use a stackable dado blade. Do not use adjustable or wobble dadoes.
- 24. NEVER PERFORM A CUTTING OPERATION USING BOTH** the rip fence and the miter gauge at the same time. This may cause kickback and serious injury to the operator.

# ELECTRICAL REQUIREMENTS AND SAFETY

## GROUNDING INSTRUCTIONS

IN THE EVENT OF A MALFUNCTION OR BREAKDOWN, grounding provides a path of least resistance for electric currents and reduces the risk of electric shock. This tool is equipped with an electrical cord that has an equipment-grounding conductor and a grounding plug. The plug must be plugged into a matching receptacle that is properly installed and grounded in accordance with all local codes and ordinances.

**DO NOT MODIFY THE PLUG PROVIDED.** If it will not fit the receptacle, have the proper receptacle installed by a qualified electrician.

**IMPROPER CONNECTION** of the equipment grounding conductor can result in risk of electric shock. The conductor with the green insulation (with or without yellow stripes) is the equipment grounding conductor. If repair or replacement of the electric cord or plug is necessary, do not connect the equipment grounding conductor to a live terminal.

**CHECK** with a qualified electrician or service person if you do not completely understand the grounding instructions, or if you are not certain the tool is properly grounded.

**USE** only 3-wire extension cords that have 3-pronged grounding plugs and 3-pole receptacles that accept the tool's plug. Repair or replace damaged or worn cords immediately.

## GUIDELINES FOR EXTENSION CORDS

**USE THE PROPER EXTENSION CORD.** Make sure your extension cord is in good condition. When using an extension cord heavy enough to carry the current your product will draw. An undersized cord will cause a drop in line voltage resulting in loss of power and overheating. The table on the right shows the correct size to use depending on cord length and nameplate ampere rating. If in doubt, use the next heavier gauge. The smaller the gauge number, the heavier the cord.

Make sure your extension cord is properly wired and in good condition. Always replace a damaged extension cord or have it repaired by a qualified technician before using it. Protect your extension cords from sharp objects, excessive heat and damp or wet areas.

Use a separate electrical circuit for your tool. This circuit must not be less than #12 wire and should be protected with a 15 amp time delay fuse. Before connecting the

motor to the power line, make sure the switch is in the off position and the electric current is rated the same as the current stamped on the motor nameplate. Running at a lower voltage will damage the motor. This tool is intended for use on a circuit that has a receptacle like the one illustrated in Fig. 1.

Fig. 1 shows a 3-pronged electrical plug and receptacle that has a grounding conductor. If a properly grounded receptacle is not available, an adapter (Fig. 2) can be used to temporarily connect this plug to a 2-contact grounded receptacle. The adapter (Fig. 2) has a rigid lug extending from it that **MUST** be connected to a permanent earth ground, such as a properly grounded receptacle box. The Canadian Electrical Code prohibits the use of adapters.

### CAUTION

**In all cases, make certain the receptacle is properly grounded. If you are not sure, have a qualified electrician check the receptacle.**

### CAUTION

**This tool is for indoor use only. Do not expose to rain or use in damp locations.**

Fig. 1

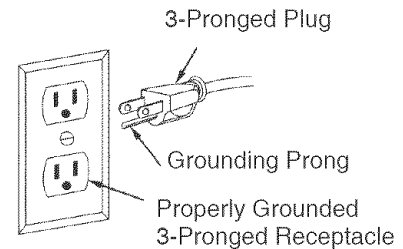
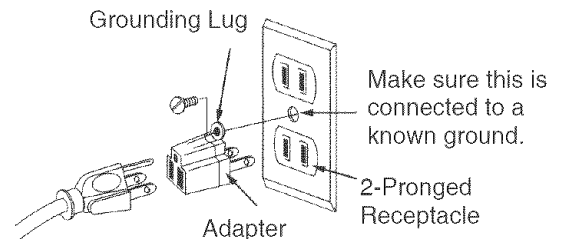

Fig. 2



### CAUTION

This tool must be grounded while in use to protect the operator from electrical shock.

MINIMUM GAUGE FOR EXTENSION CORDS (AWG)					
(When using 120 volts only)					
Ampere Rating		Total length of Cord			
More Than	Not More Than	25ft.	50ft.	100ft.	150ft.
0	6	18ft.	16ft.	16ft.	14ft.
6	10	18ft.	16ft.	14ft.	12ft.
10	12	16ft.	16ft.	14ft.	12ft.
12	16	14ft.	12ft.	Not Recommended	

## ACCESSORIES AND ATTACHMENTS

### RECOMMENDED ACCESSORIES

#### **▲ WARNING**

Visit your Sears Hardware Department or see the Sears Power and Hand Tool Catalog to purchase recommended accessories for this power tool.

#### **▲ WARNING**

To avoid the risk of personal injury, do not modify this power tool or use accessories not recommended by Sears.

To avoid the risk of personal injury:

- Do not use adjustable (wobble) type dadoes or carbide tipped dado blades; maximum dado width is 1/2 in.
- Do not use a dado with a diameter larger than 6 in.
- Do not use molding head set with this saw.
- Do not modify this power tool or use accessories not recommended by Sears.

## TOOLS NEEDED FOR ASSEMBLY

### TOOLS NEEDED

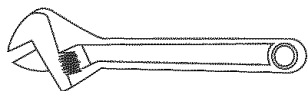

Adjustable Wrench

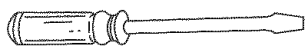

Flat Blade Screwdriver

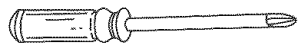

Philips Screwdriver



Steel Ruler



Combination Square

## CARTON CONTENTS

Separate all parts from packing materials. Check each part with the illustration on the next page and the "Table of Loose Parts" to make certain all items are accounted for, before discarding any packing material.

#### **▲ WARNING**

If any part is missing or damaged, do not attempt to assemble the table saw, plug in the power cord, or turn the switch ON until the missing or damaged part is obtained and is installed correctly.

### TABLE OF LOOSE PARTS

ITEM	DESCRIPTION	QUANTITY
A	Table Saw Assembly	1
B	Table Extension	2
C	Rear Table Extension	1
D	Rear Table Extension Tube	2
E	Location Seat	5
F	Blade Guard and Splitter	1
G	Guard Mounting Bolt, Flat Washer, Toothed Washer, Oval Washer, Spring Washer	1 each
H	Rip Fence	1
I	Hand Wheel	2
J	Dome Nut	2
K	Dado Table Insert	1
L	Miter Gauge	1
M	Hex Key	1
N	Blade Wrench	2
O	Blade	1
P	Dust Chute	1
Q	Dust Bag	1

### STAND

R	Short Upper Support	2
S	Long Upper Support	2
T	Short Bottom Support Bracket	2
U	Long Bottom Support Bracket	2
V	Leg	4
W	Stand Mounting Hardware	1
X	Fence Storage Hardware Bag and Extension Table Leveling Spacers	1

**NOTE:** To make assembly easier, keep contents of box together. Apply a coat of automobile wax to the table. Wipe all parts thoroughly with a clean dry cloth. This will reduce friction when pushing the workpiece. To avoid injury, the styrofoam block should be removed between the motor and the table.

# UNPACKING YOUR TABLE SAW

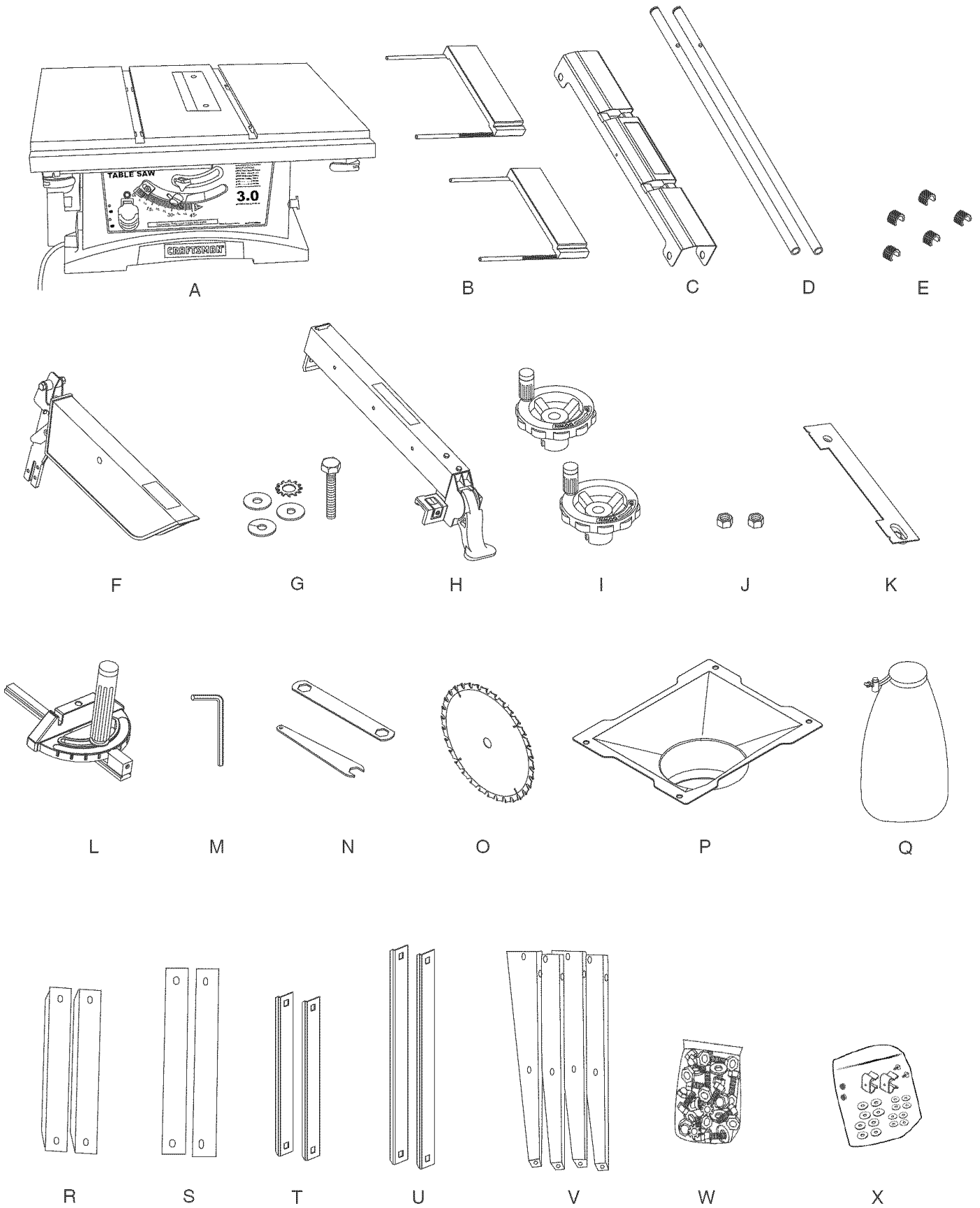

# KNOW YOUR TABLE SAW

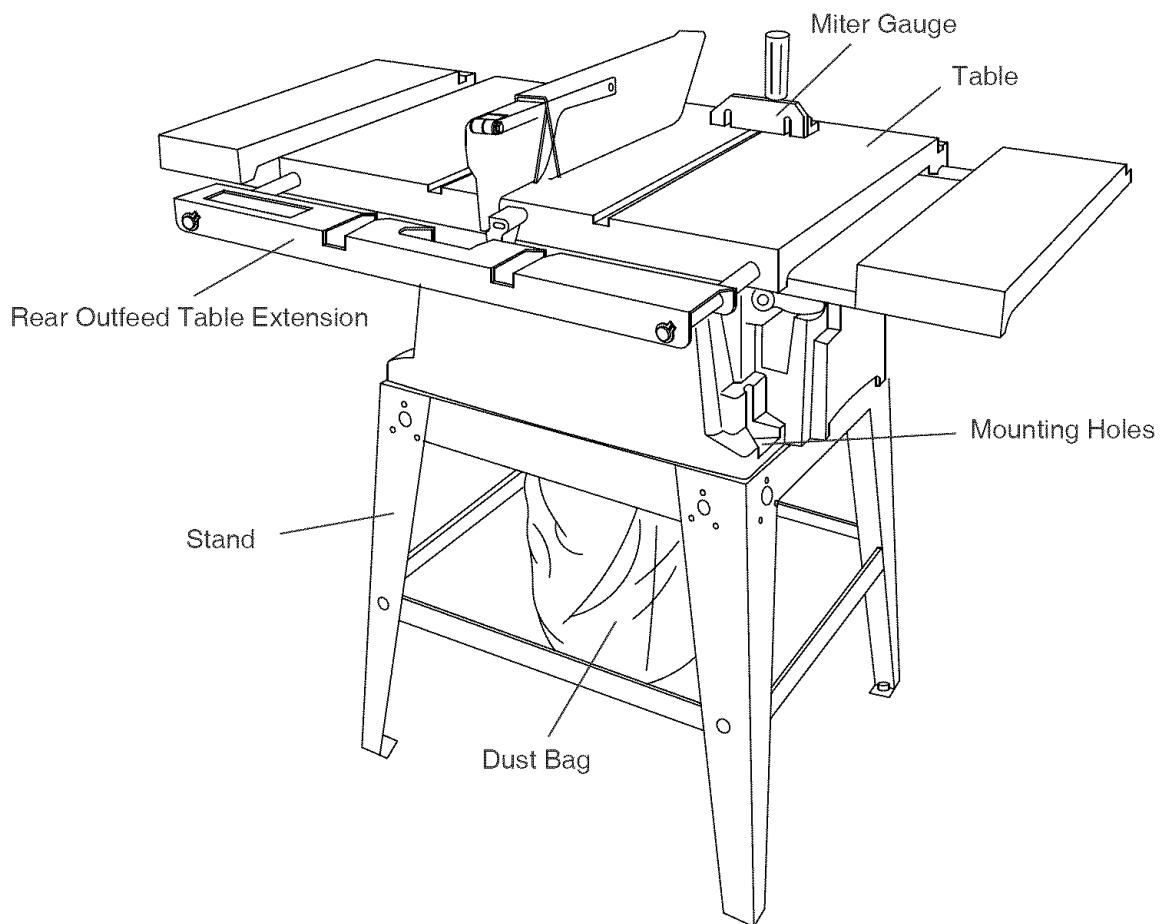
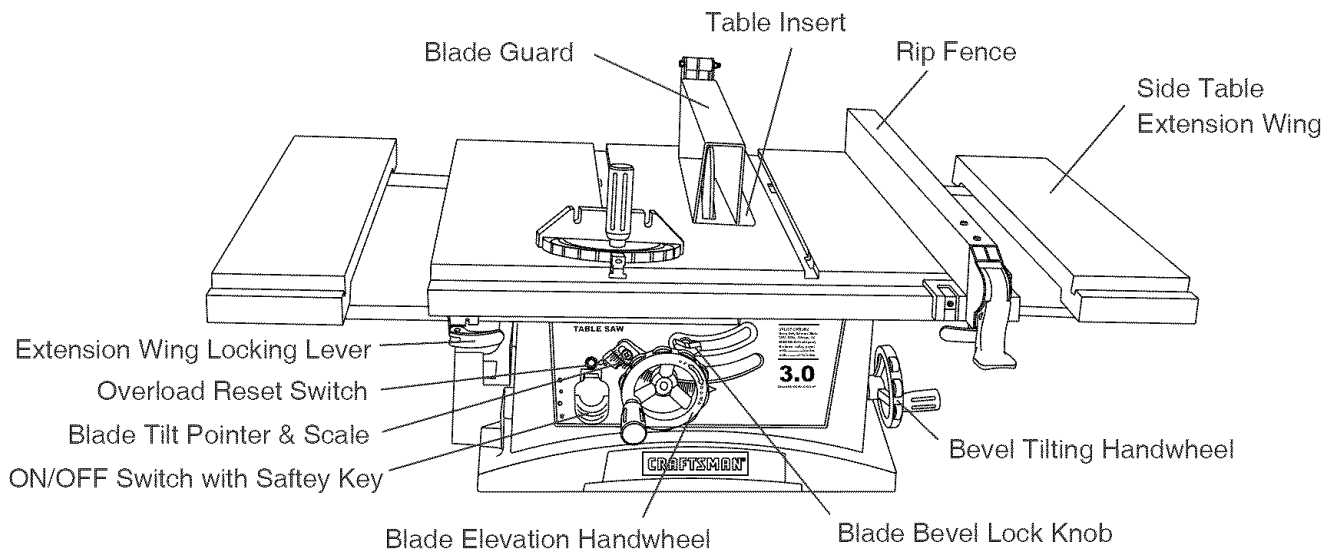



# GLOSSARY OF TERMS

**ANTI-KICKBACK PAWLS** – Prevents the work piece from being kicked upward or back toward the front of the table saw by the spinning blade.

**ARBOR** – The shaft on which the blade or dado is mounted.

**BEVEL CUT** – An angle cut made through the face of the work piece.

**BLADE BEVEL SCALE** – Measures the angle the blade is tilted when set for a bevel cut.

**BLADE ELEVATION HANDWHEEL** – Raises and lowers the blade.

**BLADE GUARD** – Clear plastic cover that positions itself over the blade while cutting.

**BLADE TILTING HANDWHEEL** – Tilts the blade to any angle between 0° and 45° for bevel cuts.

**COMPOUND CUT** – A simultaneous bevel and miter cut.

**CROSSCUT** – A cut made across the width of the work piece.

**DADO** – Special cutting blades that are used to cut grooves in a work piece.

**DUST PORT** – Hole in back of saw base for attachment of vacuum hose.

**FREEHAND** – Performing a cut without using a rip fence, miter gauge, hold down or other proper device to prevent the work piece from twisting during the cutting operation.

**GUM** – A sticky sap from wood products.

**HEEL** – Misalignment of the blade.

**JAM NUT** – Nut used to lock another nut in place on a threaded rod or bolt.

**KERF** – The amount of material removed by the blade cut.

**MITER CUT** – An angle cut made across the width of the work piece.

**MITER GAUGE** – A guide used for crosscutting operations that slides in the table top channels (grooves) located on either side of the blade. It helps make accurate straight or angle crosscuts.

**ON/OFF SWITCH** – Contains a built-in safety switch key. To lock the switch in the OFF position, remove the switch key from the switch.

**OVERLOAD RESET SWITCH** – Resets the thermocouple and provides a way to restart the saw motor if it overloads or overheats.

**PUSH STICK** – Special wooden accessory that is used to push a small work piece when working close to the saw blade.

**RESIN** – A sticky sap that has hardened.

**REVOLUTIONS PER MINUTE (RPM)** – The number of turns completed by a spinning object in one minute.

**RIP FENCE** – A guide used for rip cutting that clamps to the table top. It allows the work piece to cut straight.

**RIPPING** – Cutting with the grain of the solid wood or along the length of the work piece.

**SAW BLADE PATH** – The area of the work piece or table top directly in line with the travel of the blade or the part of the work piece that will be cut.

**SET** – The distance between two saw blade tips, bent outward in opposite directions to each other. The further apart the tips are, the greater the set.

**SPLITTER** – Keeps the work piece split apart after being cut to prevent binding on the blade and work piece.

**TABLE INSERT** – Metal insert that is removed from the table to install / remove blades. It is also removed for dado cutting. When dado cutting, a dado insert plate must be used.

**THROUGH-SAWING** – Making a cut completely through the length or width of a work piece.

**WORK PIECE** – Material to be cut.

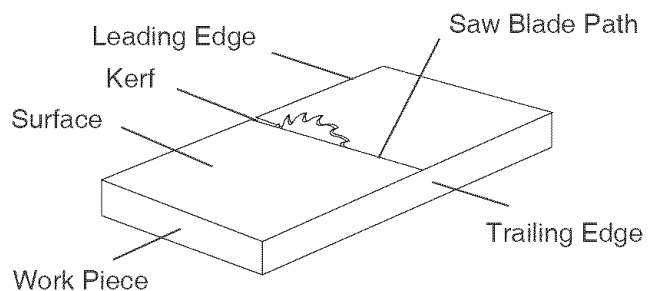

# ASSEMBLY AND ADJUSTMENTS

## ASSEMBLE STAND (FIG. A)

1. Unpack all parts and group by type and size. Refer to the parts list for correct quantities.
2. Attach one long upper support (S) to top of leg (V) using one bolt (1) and nut (2).  
**NOTE:** Do not tighten bolts until stand is properly aligned (see step #9 before tightening).
3. Attach other end of long upper support to top of another leg using one bolt and nut.
4. Attach one long bottom support (U) to center of each leg using bolt (1) and nut (2). This completes the front frame section.
5. Assemble rear frame section in exactly the same manner.
6. Join front and rear frame assemblies using two short upper supports (R) and two short bottom supports (T), bolts and nuts.
7. Insert large hex head bolt (3) into rubber foot (4) and insert into bottom of leg. Fasten with washer (5) and nut (6). Repeat for each leg.
8. Attach the fence storage hooks (16) to the frame as shown with bolt (7) and nut (8).
9. Place stand on level surface and adjust so all legs are contacting the floor and are at similar angles to the floor. Aligning the detents in the leg to the mating part of the stand then tighten all bolts.  
**NOTE:** Stand should not rock after all bolts are tightened.

Fig. A

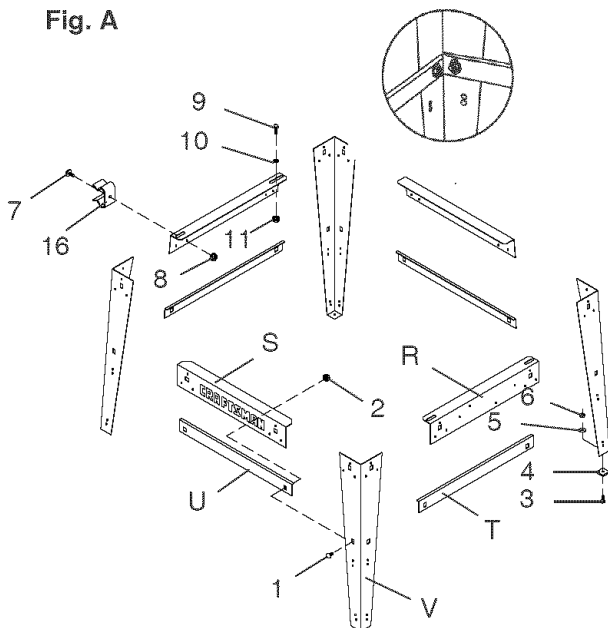

## ASSEMBLE TABLE SAW TO STAND (FIG. B)

1. Place protective cardboard or old blanket on floor to protect the saw table surface.
2. Place the saw up side down on the protective material (see Fig. B).
3. Place dust chute on the saw base so the tapered chute is facing up.
4. Position the stand up side down on the saw base.  
**NOTE:** Make sure front of stand and front of saw are facing the same direction.
5. Line up the four holes in saw base, dust chute and stand.
6. Fasten saw to stand using four bolts (9), washers (10) and nuts (11).  
**NOTE:** Place washer on each bolt before inserting into saw base and through the support. Nut must be immediately against the bracket (see Fig. A).
7. Tighten all four nuts.  
**NOTE:** Do not over tighten nuts holding saw to stand. This may damage the saw base. After the hardware is finger-tight, turn two full times.
8. Carefully set the saw in its upright position on a clean level surface.

### **WARNING**

If the stand will not be used, do not operate the table saw on the floor. This is a very dangerous position.

Fig. B

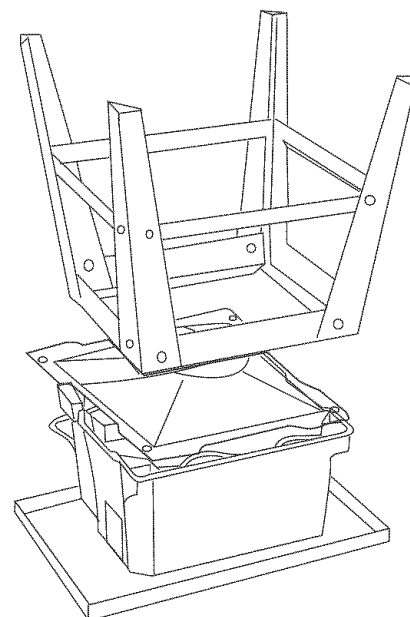

### MOUNT SAW ON WORK SURFACE (FIG. C)

1. If the leg set will not be used, the saw must be properly secured to a sturdy workbench using the four mounting holes at the base of the saw.
2. The surface of the table where the saw is to be mounted must have a hole large enough to facilitate sawdust fall-through and removal.
3. Square the saw on the mounting surface and mark the location of the four 3/8 in. mounting holes (1).
4. Drill 3/8 in. hole into the mounting surface.
5. Mark an 11 in. square (2) centered between the four mounting holes (1).
6. Cut out and remove the square.
7. This opening will allow sawdust to fall through the saw base.
8. Place the saw on the work surface, and align the mounting holes of the saw with those drilled through the surface.
9. Fasten the saw to the work surface.

#### **▲ WARNING**

Do not operate this machine on the floor. This is very dangerous and may cause serious injury.

Fig. C

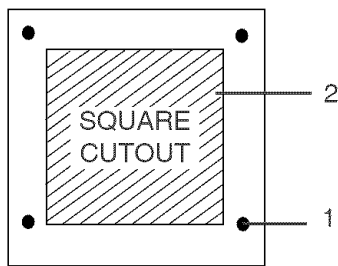

#### **▲ WARNING**

Failure to provide the sawdust fall-through hole for use of the saw when mounted to a work surface and not the stand will cause sawdust to build up in the motor area, which may result in fire or cause motor damage.

#### **▲ WARNING**

Always keep your work area clean, uncluttered and well lit.

### INSTALLING THE DUST BAG (FIG. D)

#### **▲ WARNING**

Do not use this saw to cut and/or sand metals. The hot chips or sparks may ignite sawdust or the bag material.

Place the dust bag around the neck of the dust chute and tie the dust bag pulling the string tight and secure with the spring-loaded tie clip.

Fig. D

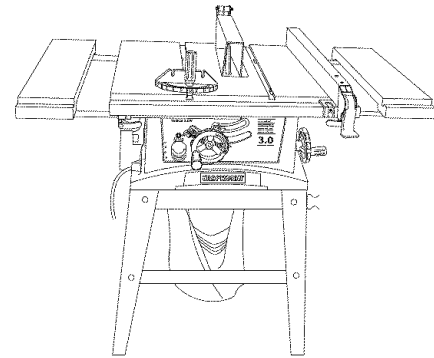

### BLADE RAISING HANDWHEEL (FIG. E, F)

1. Attach the up ~ down handwheel (1) to the elevation rod (2) at the front of the saw. Make sure the slots (3) in the hub of the handwheel (1) engage with the pins (4).
2. Attach and tighten the dome nut (5 - Fig. F).

Fig. E

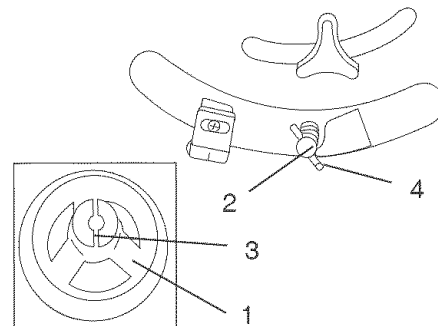

### BLADE TILTING HANDWHEEL (FIG. F)

1. Attach the bevel 0° ~ 45° handwheel (6) to the blade tilting rod on the right side of the saw in the same manner as above.
2. Attach and tighten the handwheel dome nut (5).

Fig. F

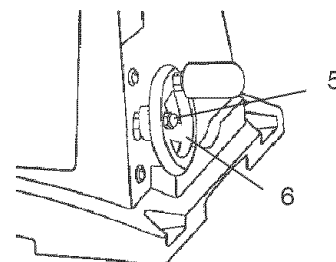

### RIP FENCE (Fig. G)

1. Lift upward on the rip fence handle (1) so the rear holding clamp (2) is fully extended.
2. Place the rip fence on the saw table, lowering the front of the fence onto the table first.
3. Push down on the fence handle (1) to lock.

Fig. G

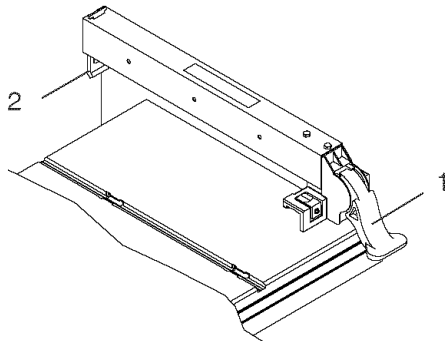

### INSTALLING AND CHANGING THE BLADE (FIG. H, I, J)

#### ⚠ WARNING

- To avoid injury from an accidental start, make sure the switch is in the OFF position and the plug is not connected to the power source outlet.
- To avoid serious injury, the rear of the table insert must be level with the table. If the rear of the insert is not level with the table, adjust the screw (3) in or out until the rear of the insert is level to or slightly above the table. To raise the insert, turn the screw counterclockwise, to lower the insert, turn the screw clockwise. **NOTE:** A rubber adjusting spacer is provided under rear of insert for this purpose.

1. Remove the table insert (1) by removing the two screws (2, 3). Be careful not to lose the rubber spacer that is on the back screw (3) beneath the table insert (Fig. H).

Fig. H

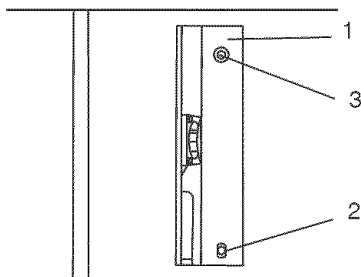

2. Raise the blade arbor (4) (Fig. I) to the maximum height by turning the blade raising handwheel counterclockwise.
3. Place the open-end wrench (8) jaws on the flats of the saw arbor to keep the arbor from turning (Fig. J) and place the box-end wrench (9) on the arbor nut (5), and turn counterclockwise.

4. Remove the arbor nut (5) and outer flange (6) (Fig. I).
5. Install the saw blade onto the arbor with the **BLADE TEETH POINTING TOWARD THE FRONT OF THE SAW.**
6. Install the flange (6) against the blade and thread the arbor nut (5) as far as possible by hand. Ensure that the blade is flush against the inner side of the blade flange.

#### ⚠ WARNING

To avoid possible injury and damage to the workpiece, be sure to **INSTALL THE BLADE WITH THE TEETH POINTING TOWARD THE FRONT OF TABLE** in the direction of the rotation arrow on the blade guard.

Fig. I

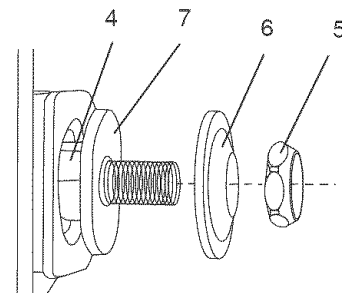

7. To tighten the arbor nut, (5) place the open-end wrench (8) on the flats of the saw arbor to keep the arbor from turning (Fig. J).
8. Place the box-end wrench (9) on the arbor nut (5), and turn clockwise (to the rear of the saw table).
9. Replace the blade insert in the table recess, insert the screws through the front and rear holes and tighten remembering the rubber washer under the rear of the insert and leveling the rear of the insert to the table.

Fig. J

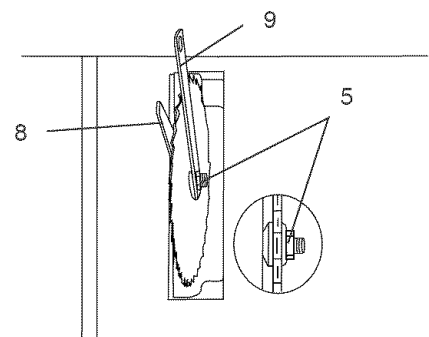

#### ⚠ WARNING

To avoid injury from a thrown workpiece, blade parts, or blade contact, never operate saw without the proper insert in place. Use the original installed insert for all through sawing operations except dado cuts. A special dado insert plate must be installed when using a dado blade.

## BLADE GUARD ASSEMBLY (FIG. K, L, M)

1. Set the blade to maximum height and the tilt to zero degrees on the bevel scale with the hand wheels. Lock the blade bevel lock knob.
2. Place the spring washer (2), flat washer (3), external tooth lock washer (4) onto the blade guard mounting bolt (1) (Fig. K).
3. Insert bolt and washer assembly through splitter bracket (5).

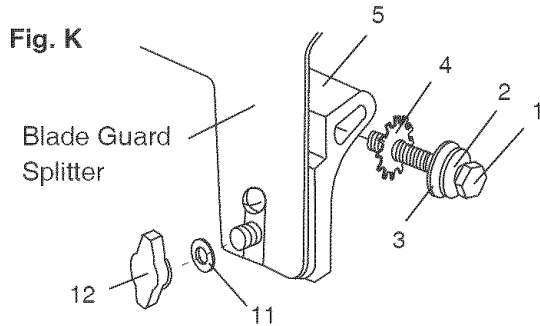

4. Place the oval washer (6) on the pivot rod (7) (Fig. L).
5. Install the blade guard splitter & bracket assembly into the rear of the saw table. Thread the bolt (1) into the internally threaded pivot rod until snug.  
**NOTE:** The blade guard and splitter is removed from the illustration for clarity.

Fig. L

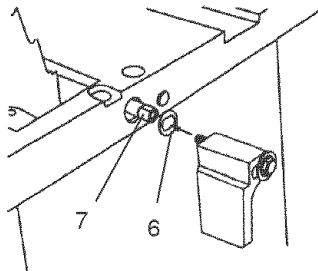

6. Lift blade guard arm (8) up and using a straight edge, align the blade guard splitter (9) with the saw blade (10).
7. Shift the splitter bracket assembly to right or left until parallel alignment to the blade is achieved.
8. When the splitter is properly aligned with the saw blade, tighten the bolt securely.  
**NOTE:** The splitter bracket must always be correctly aligned so the cut workpiece will pass on either side without binding or twisting.

## CAUTION

See Fig. K flat washer (11) must be under knob (12). **NOTE:** Be sure to tighten knob very tight and periodically check tightness.



Improper splitter alignment can cause “kickback” and serious injury.

Fig. M

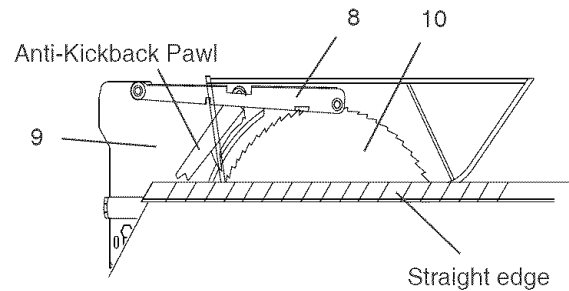

## INSTALLING TABLE SIDE EXTENSIONS (FIG. N)

1. Identify the right hand table extension.  
**NOTE:** For illustration purposes the view in Fig. N looks “through” the saw table to the under side of the table. The right hand table extension is the one with the measuring scale visible from the front of the saw when it is installed to the right hand side of the saw table.
2. Unlock both front and rear cam locking levers (1) on the right hand side of the saw base by flipping the lever over.
3. Insert the table extension mounting tubes (2) into the two matching holes in the cam lever assemblies.  
**NOTE:** Make sure the front mounting tube has the measuring scale visible from the front of the saw.
4. Slide the table extension toward the table until it rests against the saw table.
5. Lock both cam locking levers by pushing them in toward the cam locking lever assemblies.
6. If the extension is not level to the table, adjust by inserting the spacers (Carton Contents X) between the extension and the tube it mounts onto. See page 17.

Fig. N

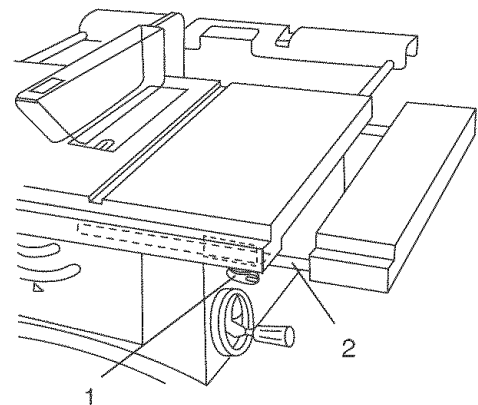

## INSTALLING THE TABLE SIDE EXTENSIONS- cont'd (FIG. O)

6. Snap one short location seat (1) over the end of the rear table extension tube (2). Make sure the locating pin (3) in the location seat fits into the matching hole in the extension tube (Fig. O).
7. Install the left hand table extension the same manner.

**NOTE:** For illustration purposes, the view in Fig. O looks "through" the saw table to the under side of the table.

Fig. O

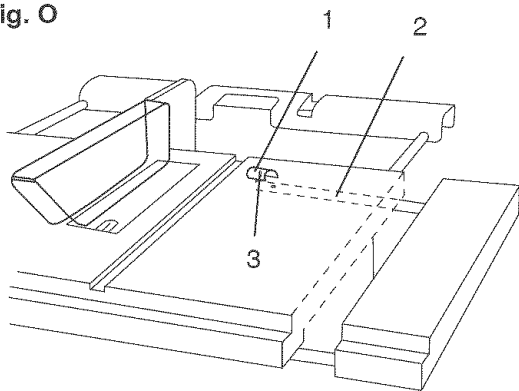

## INSTALLING REAR TABLE EXTENSION (FIG. P)

1. Place the rear table extension onto the two rear table extension tubes (1).
2. Snap two long location seats (4) over the two rear table extension tubes (1). Make sure the locating pin in the location seat fits into the matching hole (5) in the extension tube.
3. Insert rear table extension tubes (1) into the two holes in the rear of the saw table and into extension tube brackets under the table. Position rear table support so instruction labels are facing up.
4. Snap one short location seat (6) over the end of the left rear table extension tube (1). Make sure the locating pin in the location seat fits into the matching hole in the extension tube.

Fig. P

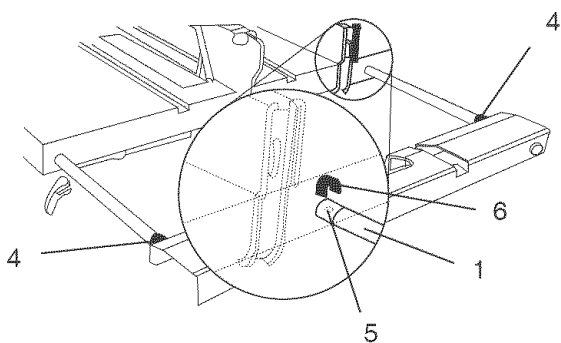

## ADJUSTING REAR TABLE EXTENSION

1. Rear table extension should be positioned as close as possible to the rear of the table when ripping short work pieces.
2. Rear table extension should be pulled out fully until the location seat prevents it from moving outward when ripping long work pieces that require extra support as you are completing the cut.

## RIP FENCE ADJUSTMENT (FIG. Q)

1. The fence (1) is moved by lifting up on the handle (2) and sliding the fence to the desired location. Pushing down on the handle locks the fence in position.
2. Position the fence on the right side of the table and along the edge miter gauge groove.
3. Lock the fence handle. The fence should be parallel with the miter gauge groove.
4. If adjustment is needed to make the fence parallel to the groove, do the following:
  - Loosen the two screws (3) and lift up on the handle (2).
  - Hold the fence bracket (4) firmly against the front of the saw table. Move the fence until it is parallel with the miter gauge groove.
  - Push the handle down and tighten both screws.
5. If fence is loose when the handle is in the locked (downward) position, do the following:
  - Move the handle (2) upward and turn the adjusting nut (5) clockwise until the rear clamp is snug.
  - Over-tightening the adjusting screw will cause the fence to come out of alignment.

## **WARNING**

Failure to properly align fence can cause "kickback" and serious injury.

Fig. Q

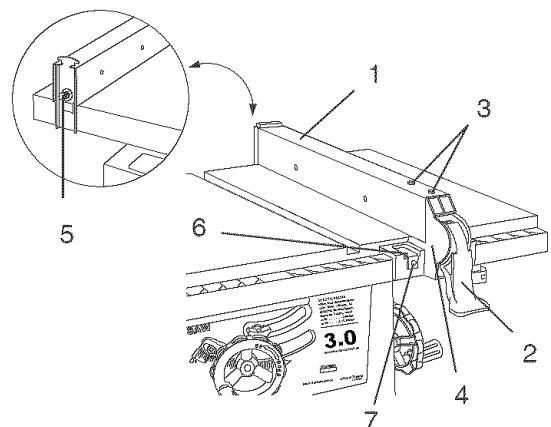

### RIP FENCE INDICATOR ADJUSTMENT (FIG. Q)

1. The rip fence indicator (6) points to the measurement scale. The scale shows the distance from the side of the fence to nearest side of the blade.
2. Measure the actual distance with a rule. If there is a difference between the measurement and the indicator, adjust the indicator (6).
3. Loosen the screw (7) and slide the indicator to the correct measurement on the scale. Tighten the screw and remeasure with the rule.

### WARNING

To avoid injury from an accidental start, make sure the switch is in the OFF position and the plug is not connected to the power source outlet.

### ADJUSTING THE 90° (0°) AND 45° POSITIVE STOPS (FIG. R, S, T)

Your saw has positive stops that will quickly position the saw blade at 90° (0°) to the table. Make adjustments only if necessary.

#### 90° (0°) Stop

1. Disconnect the saw from the power source.
2. Turn the blade elevation handwheel and raise the blade to the maximum elevation.
3. Loosen the blade bevel lock knob (1) and move the blade to the maximum vertical position, then tighten the lock knob (1).
4. Place a combination square on the table and against the blade (2) to determine if the blade is 90° (0°) to the table. (Fig. S)
5. If the blade is not 90° (0°) to the table, loosen the two set screws (4), located on the collar (5) underneath the table saw (Fig. T) with the hex key and back off the collar.
6. Loosen the bevel lock knob, turn the blade tilting handwheel to move the blade until it is 90° (0°) to the table and tighten the bevel lock knob.
7. Adjust the collar (5) so it contacts the bracket (3) when the blade is 90° (0°) to the table. Tighten the two set screws (4) (Fig. T).

Fig. R

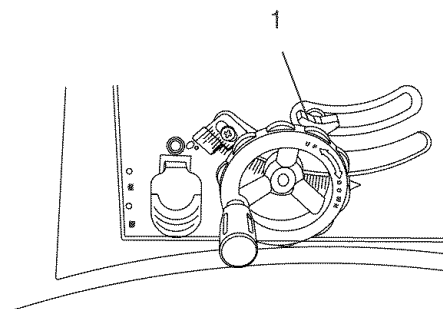
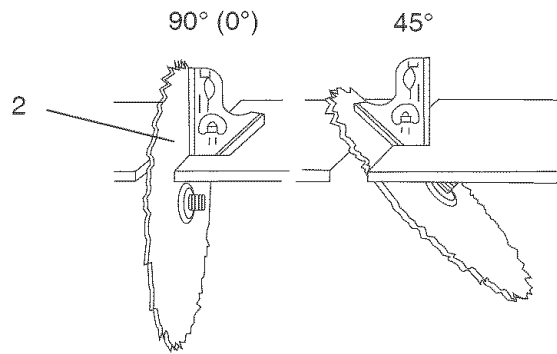

Fig. S



#### 45° Stop

1. With the blade in the upright 90° (0°) position, loosen the bevel lock knob and move the blade to the maximum bevel angle.
2. Place the combination square on the table as shown in Fig. S to check if the blade is 45° to the table.
3. If the blade is not 45° to the table, loosen the two set screws (4), located on the collar (5) underneath the table saw, (Fig. T) with the hex key, and back off the collar.
4. Loosen the blade bevel lock knob, turn the blade tilting handwheel to move the blade until it is 45° to the table and tighten the blade bevel lock knob.
5. Adjust the collar (5) so it contacts the bracket (3) when the blade is 45° to the table. Tighten the two set screws.

#### BLADE TILTING POINTER

1. When the blade is positioned at 90° (0°), adjust the blade tilt pointer to read 0° on the scale.
2. Loosen the mounting screw, position pointer over 0° and tighten the screw.

**NOTE:** Make a trial cut on scrap wood before making critical cuts. Measure for exactness.

Fig. T

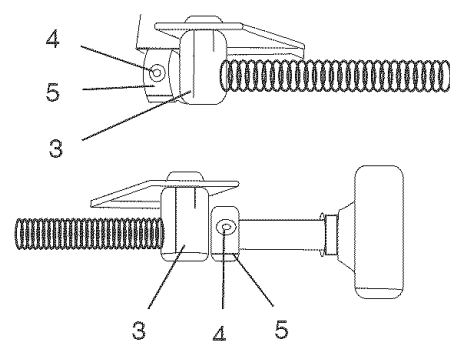

## BLADE PARALLEL TO THE MITER GAUGE GROOVE (FIG. U, V)

### **▲ WARNING**

This adjustment was made at the factory, but it should be rechecked and adjusted if necessary.

### **▲ WARNING**

To prevent personal injury:

- Always disconnect plug from the power source when making any adjustments.
- This adjustment must be correct or kickback could result in a serious injury and accurate cuts can not be made.

1. Remove the safety switch key and unplug the saw.
2. Remove the blade guard for this procedure but reinstall and realign after adjustment.
3. Raise the blade to the highest position and set at the 0° angle (90° straight up).
4. Select and mark, with a felt tip maker, a blade tooth having a "right set" and rotate the blade so the marked tooth is ½ in. above the table.
5. Place the combination square base (1) into the right side miter gauge groove (2). (Fig. U)
6. Adjust the rule so it touches the front marked tooth and lock ruler so it holds its position in the square assembly.
7. Rotate the blade bringing the marked tooth to the rear and about ½ in. above the blade.
8. Carefully slide the combination square to the rear until the ruler touches the marked tooth.
9. If the ruler touches the marked tooth at the front and rear position, no adjustment is needed at this time. If not or the base of the rule is no longer parallel with the edge of the miter gauge groove, perform adjustment procedure described in next section.

Fig. U

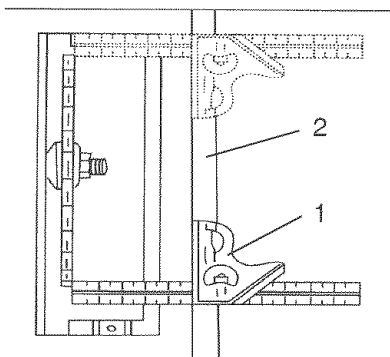

## Additional blade adjustments (Fig. V)

**NOTE:** The adjusting nuts are 8mm.

The adjusting mechanism is located above the blade height adjusting hand wheel under the tabletop. If the front and rear measurements are not the same.

### If the blade is partial to right side:

1. Loosen the two nuts (1) and turn the left screw (2) counterclockwise, then adjust the right side screw (3) clockwise.
2. Remeasure, as described in steps 4 to 9 in the prior section.
3. When alignment is achieved, turn the left screw (2) until it touches the pivot rod (4) then tighten both nuts (1).

### If the blade is partial to left side:

1. Loosen the two nuts (1) and turn the right screw (3) counterclockwise, then adjust the left side screw (2) clockwise.
2. Remeasure, as described in steps 4 to 9 in the prior section.
3. When alignment is achieved, turn the right screw (3) until it touches the pivot rod (4) then tighten both nuts (1).

Fig. V

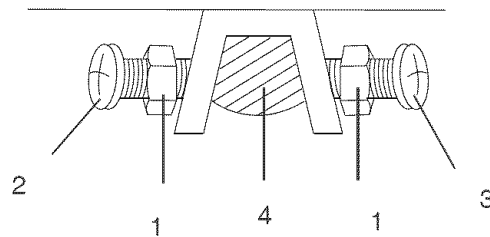



# OPERATION

## BASIC SAW OPERATIONS

### RAISE THE BLADE (FIG. W)

To raise or lower the blade, turn the blade elevation handwheel (1) to the desired blade height, and then tighten lock handle (2) to maintain the desired blade angle.

Fig. W

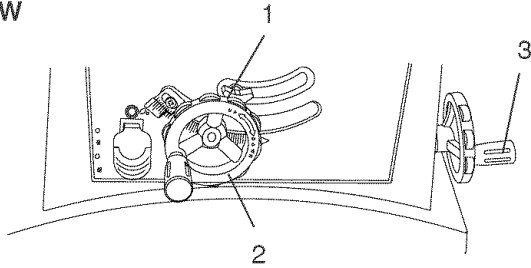

### TILTING THE BLADE (FIG. W)

1. To tilt the saw blade for bevel cutting, loosen the bevel lock knob (2) and turn the tilting handwheel (3).
2. Tighten the bevel lock knob (2) to secure.

### ON/OFF SWITCH (FIG. X)

The ON / OFF switch has a removable safety key. With the key removed from the switch, unauthorized and hazardous use by children and others is minimized and the saw will not turn on.

1. To turn the saw ON, insert key (1) into the slot in the switch (2). Move the switch upward to the ON position.
2. To turn the saw OFF, move the switch downward.
3. To lock the switch in the OFF position, grasp the sides (or yellow part) of the switch toggle (1), and pull it out.
4. With the switch key removed, the switch will not operate.
5. If the switch key is removed while the saw is running, it can be turned OFF but cannot be restarted without re-inserting the switch key (1).

Fig. X

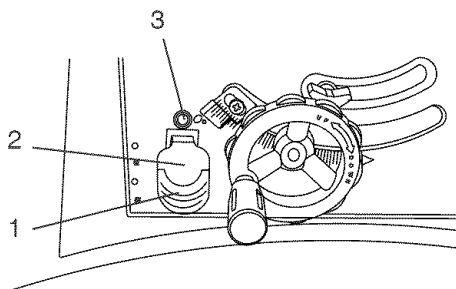

### OVERLOAD PROTECTION (FIG. X)

This saw has an overload relay button (3) that resets the motor after it shuts off due to overloading or low voltage. If the motor stops during operation, turn the ON / OFF switch to the OFF position and unplug the saw. Wait about five minutes for the motor to cool. Plug in the saw, push in the reset button (3) and turn the switch to the ON position.

### ▲ WARNING

To avoid injury, the ON / OFF switch should be in the OFF position and the plug removed from the power source while the cool down takes place, to prevent accidental starting when the reset button is pushed. Overheating may be caused by misaligned parts or a dull blade or undersized extending cord. Inspect your saw for proper setup before using it again.

### USING THE TABLE EXTENSION (FIG. Y, Z)

If the table extension is not parallel with the table, remove the bolts (1) and position the extension leveling spacers (2) between the table extension and tube until it is parallel with the table, then tighten the bolts.

**NOTE:** See page 6 for table of loose parts ITEM: X

Fig. Y

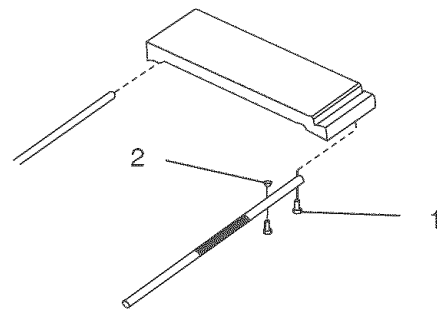

1. Release the extension cam locking levers.
2. Slide the extension out until the correct measurement is displayed on the tube scale. The user sights the scale off the edge of the table.
3. Tighten all extension lock handles.

Fig. Z

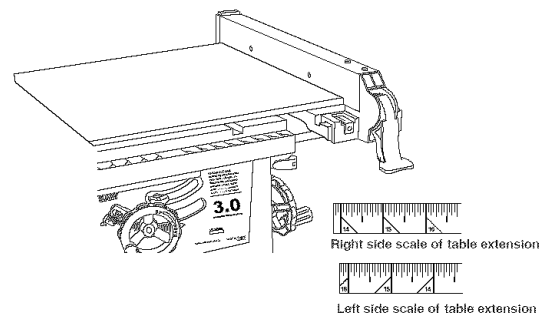

## CUTTING OPERATIONS

There are two basic types of cuts: ripping and crosscutting. Ripping is cutting along the length and the grain of the workpiece. Crosscutting is cutting either across the width or across the grain of the workpiece. Neither ripping nor crosscutting may be done safely freehand. Ripping requires the use of the rip fence, and crosscutting requires the miter gauge. **Never use the two cut the same time.**

### **▲ WARNING**

Before using the saw each and every time, check the following:

1. Blade is tight on the arbor.
2. Bevel angle lock knob is tight.
3. If ripping, fence knob is tight and fence is parallel to the miter gauge grooves.
4. Blade guard is in place and working properly.
5. Safety glasses are being worn.

The failure to adhere to these common safety rules, and those printed in the front of this manual, can greatly increase the likelihood of injury.

## RIPPING (FIG. AA, BB)

### **▲ WARNING**

- Never use the miter gauge when ripping.
- Never use more than one rip fence during a single cut.
- Keep both hands away from the blade and path of the blade.
- The workpiece must have a straight edge against the fence and must not be warped, twisted, or bowed.
- Do not allow familiarity or frequent use of your table saw to cause careless mistakes. Remember that even a careless fraction of a second is enough to cause a severe injury.

1. Remove the miter gauge. Secure the rip fence to the table at the desired rip measurement.
2. Raise the blade so it is about 1/8 in. higher than the top of the workpiece.
3. Place the workpiece flat on the table and against the fence so the larger portion of the workpiece is between the blade and the fence. Keep the workpiece about 1 in. away from the blade.
4. Turn the saw ON and wait for the blade to come up to speed.

5. Slowly feed the workpiece into the blade by pushing forward only on the workpiece section (1) that will pass between the blade and the fence. (Fig. AA)

### **▲ WARNING**

**AVOID KICKBACK** by pushing forward on the section of the workpiece that will pass between the blade and the fence. Use a push stick at all times.

Fig. AA

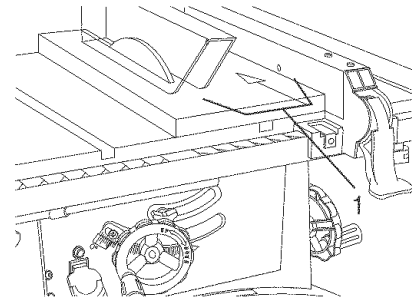

### **▲ WARNING**

Always use a push stick. When width or rip narrower than 2 in. the push stick cannot be used because the guard will interfere... Use the auxiliary fence as shown are page 20.

6. Keep your thumbs off the table top. When your hand reaches the front edge of the table (2), finish the cut with a push stick (3) (Fig. BB). You can make a push stick using the pattern on page 28.
7. **The push stick (3) should always be used during all ripping operations. (Fig. BB)**
8. Continue pushing the workpiece with the push stick (3) until it passes the blade guard and clears the rear of the table.

### **▲ DANGER**

**Never attempt to pull the workpiece backwards during a cutting operation. This will cause kickback and serious injury to the user can occur. When the blade completely stops raise the anti-kickback pawls on each side of the splitter and slide the workpiece out.**

Fig. BB

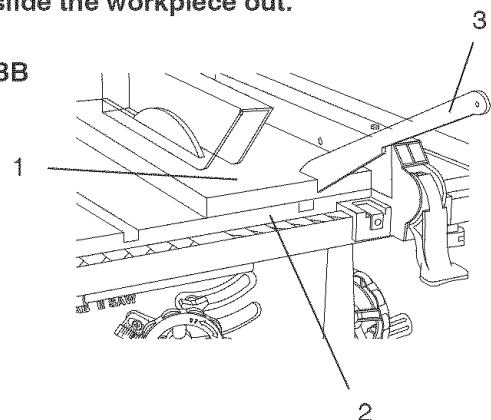

## BEVEL RIPPING

This cut is the same as ripping except the blade bevel angle is set to an angle other than "0".

### **▲ WARNING**

**Cut only with the workpiece and the fence on the right side of the blade.**

## RIPPING SMALL PIECES

### **▲ WARNING**

**Avoid injury from the blade contact. Never make through saw cuts narrower than 1/2 in. wide.**

1. It is unsafe to rip small pieces. Instead, rip a larger piece to obtain the size of the desired piece.
2. When a small width is to be ripped, your hand cannot be safely put between the blade and the rip fence, therefore, use one or more push sticks to pass the workpiece completely through and past the blade.

## CROSSCUTTING 90° MITER ANGLE (FIG. CC)

### **▲ WARNING**

**To prevent serious injury:**

- Do not allow familiarity or frequent use of your table saw to cause careless mistakes. Remember that even a careless fraction of a second is enough to cause a severe injury.
- Keep both hands away from the blade and the path of the blade.

1. Remove the rip fence and place the miter gauge in one miter gauge groove of the table.
2. Adjust the blade height so it is 1/8 in. higher than the top of the workpiece.
3. Hold the workpiece firmly against the miter gauge with the blade path in line with the desired cut location. Keep the workpiece away from the blade.
4. Start the saw and wait for the blade (1) to come up to full speed.
5. Keep the workpiece (2) against the face of the miter gauge (3) and flat against the face of the gauge and flat against the table. Then slowly push the workpiece through the blade. (Fig. CC)
6. Do not try to pull the workpiece back with the blade turning. Turn the switch OFF, and carefully slide the workpiece out when the blade is completely stopped.

### **▲ WARNING**

**Always position the larger surface of the workpiece on the table when crosscutting and/or bevel crosscutting to avoid instability.**

## USING WOOD FACING ON THE MITER GAUGE

### (Fig. DD)

Slots are provided in the miter gauge for attaching an auxiliary facing (1) to make it easier to cut very long or short pieces. Select a suitable piece of smooth wood, drill two holes through it and attach it the miter gauge face with screws. Make sure the facing does not interfere with the proper operation of the sawblade guard. When cutting long workpieces, you can make a simple support by clamping a piece of plywood to a sawhorse.

Fig. CC

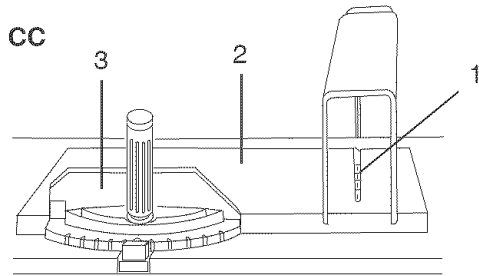
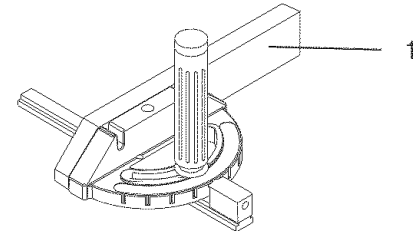

Fig. DD



## BEVEL CROSSCUTTING (FIG. EE) 0°-45° BLADE BEVEL & 90° MITER ANGLE

This cutting operation is the same as crosscutting except the blade is at bevel angle other than 0°.

### **▲ WARNING**

**Always work to the right side of the blade during this type of cut. The miter gauge must be in the right side groove because the bevel angle may cause the blade guard to interfere with the cut if used on the left side groove.**

1. Adjust the blade (1) to the desired angle, and tighten the blade bevel lock knob.
2. Tighten miter lock handle (3) at 90°.
3. Hold workpiece (2) firmly against the face of the miter gauge throughout the cutting operation.

Fig. EE

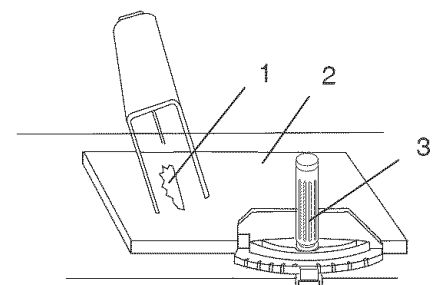

**COMPOUND MITER CROSSCUTTING (FIG. FF)**  
**0°~45° BLADE BEVEL & 0°~45° MITER ANGLE**

This sawing operation is combining a miter angle with a bevel angle.

**WARNING**

Always work to the right side of the blade during this type of cut. The miter gauge must be in the right side groove because the bevel angle may cause the blade guard to interfere with the cut if used on the left side groove.

1. Set the miter gauge (3) to the desired angle.
2. Place the miter gauge in the right side groove of the table.
3. Set the blade (1) bevel to the desired bevel angle and tighten the blade bevel lock knob.
4. Hold workpiece (2) firmly against the face of the miter gauge throughout the cutting operation.

Fig. FF

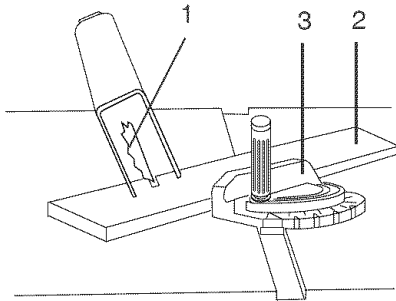

**MITERING (FIG. GG) 0°~45° MITER ANGLE**

This sawing operation is the same as crosscutting except the miter gauge is locked at an angle other than 90°

1. Set the blade (1) to 0° bevel angle and tighten the blade bevel lock knob.
2. Set the miter gauge (3) at the desired miter angle and lock in position by tightening the miter gauge locking handle.
3. Hold the workpiece (2) firmly against the face of the miter gauge throughout the cutting operation.

Fig. GG

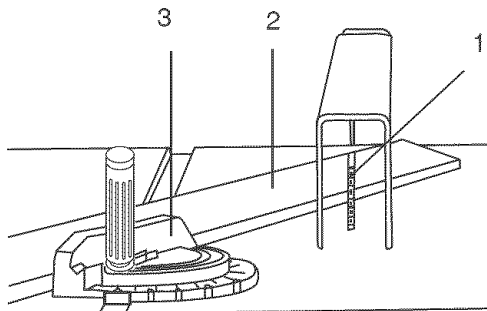

**USING WOOD FACING ON THE RIP FENCE (FIG. HH)**

When performing some special cutting operations, add a wood facing (1) to either side of the rip fence (2).

1. Use a smooth straight 3/4 in. thick wood board (1) that is as long as the rip fence.
2. Attach the wood facing to the fence with wood screw (3) through the holes in the fence. A wood fence should be used when ripping material such as thin paneling to prevent the material from catching between the bottom of the fence and the table.

Fig. HH

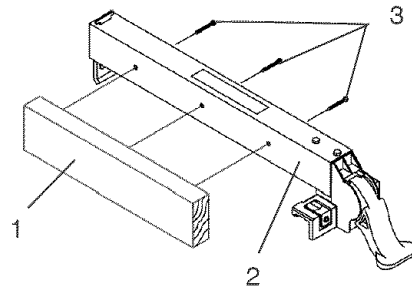

**AUXILIARY FENCE (FIG. II)**

**Making the base:**

- Start with a piece of 3/8 in. plywood at least 5-1/2 in. wide or wider and 30" long or longer.
- Cut the piece to shape and size shown:

**Making the side:**

- Start with a piece of 3/4 in. plywood at least 2-3/8 in. wide or wider and 27 in. long or longer/
- Cut the piece to shape and size shown:

**Putting it together:**

- Put the pieces together, as shown:

**WARNING**

Make sure the screw heads do not stick out from the bottom of the base, they must be flush or recessed. The bottom must be flat and smooth enough to rest on the saw table without rocking.

Fig. II

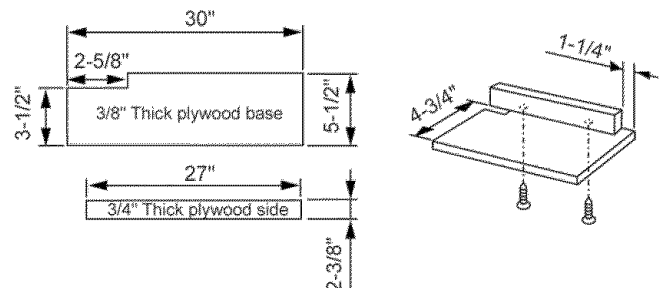

Attach auxiliary fence to rip fence with two "C" clamps.  
(Fig. JJ)

Fig. JJ

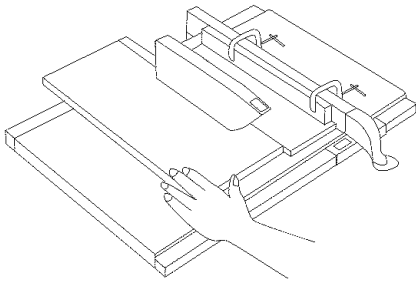

#### DADO CUTS (FIG. KK)

##### **WARNING**

- a. Only Stackable dado blades can be used on this saw.
- b. DO NOT use Adjustable or Wobble type dados.
- c. Maximum dado cut width is ½ in.
1. A dado table insert must be purchased separately for this saw to accept a dado blade. Remove saw blade and blade guard for dado cuts ONLY. Reinstall and realign blade guard for all through sawing operations. Install a dado not exceeding 6 in. in diameter and ½ in. in width
2. Install the dado table insert making sure the rear of the insert is flush with the table. A rubber adjusting spacer is provided under the rear of the insert for this purpose.
3. Instruction for operating the dado is packed with the separately purchased dado set.
4. The arbor (1) on this saw restricts the maximum width of the cut to ½ in.
5. It is not necessary to install the outside flange (2) before threading on the arbor nut (3) for maximum ½ in. dado cuts. Make sure that the arbor nut (3) is tight, and that at least one thread of the arbor sticks out past the nut.
6. Use only the correct number of round outside blades and inside chippers as shown in the dado set's instruction manual. Blade/chippers must not exceed ½ in. total in width.
7. Check saw to ensure that the dado will not strike the housing, insert, or motor when in operation.

##### **WARNING**

For your own safety, always replace the blade, blade guard assembly, and blade insert when you are finished with the dado operation. You must also realign the blade guard assembly.

Fig. KK

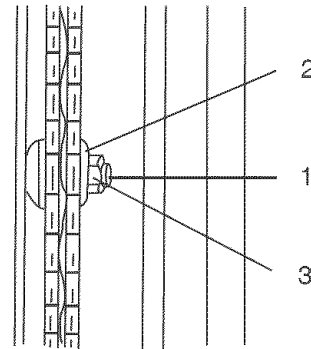

# MAINTENANCE

## GENERAL MAINTENANCE

### **▲ WARNING**

For your own safety, turn the switch OFF and remove the switch key. Remove the plug from the power source outlet before maintaining or lubricating your saw.

1. Clean out all sawdust that has accumulated inside the saw cabinet and the motor.
2. Polish the saw table with an automotive wax to keep it clean and to make it easier to slide the work piece.
3. Clean cutting blades with pitch and gum remover.
4. A worn, cut, or damaged power cord should be replaced immediately.

### **▲ WARNING**

All electrical or mechanical repairs should be attempted only by a trained repair technician. Contact the nearest Sears Service Center for service. Use only identical replacement parts. Any other parts may create a hazard.

5. Use liquid dish washing detergent and water to clean all plastic parts.  
**NOTE:** Certain cleaning chemicals can damage plastic parts.
6. Avoid use of the following cleaning chemicals or solvents, ammonia and household detergents containing ammonia.

## BLADE RAISING AND TILTING MECHANISM (FIG. LL)

After each five hours of operation, the blade raising mechanism and tilting mechanism should be checked for looseness, binding, or other abnormalities. With the saw dis-connected from the power source, turn the saw upside down and alternately pull upward and downward on the motor unit. Observe any movement of the motor mounting mechanism. Looseness or play in the blade raising screw (1) should be adjusted as follows:

1. Using a wrench, loosen nut (2).
2. Adjust nut (3) until it is finger-tight against the bracket (4), and then back off the nut (3) 1/6 turn.
3. Tighten nut (2) with the wrench, while holding nut (3) in place. Maximum allowable play of screw rod (1) is 0.16 in. (4 mm).

Fig. LL

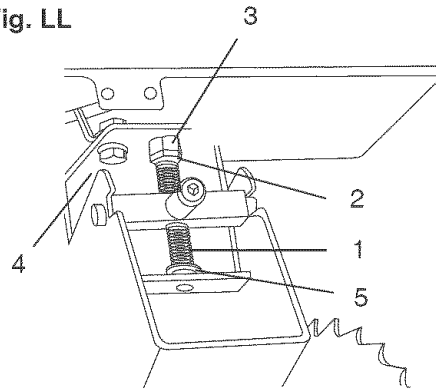

Place a small amount of dry lubricant on height regulating bolt (1). This must be kept clean and free of sawdust, gum, pitch, and other contaminants for smooth operation.

If excessive looseness is observed in any parts of the blade raising mechanism or tilting mechanism, take the complete unit to a Sears Service Center.

## LUBRICATION

All motor bearings are permanently lubricated at the factory and require no additional lubrication. On all mechanical parts of your table saw where a pivot or threaded rod are present, lubricate using graphite or silicone. These dry lubricants will not hold sawdust as would oil or grease.

# TROUBLESHOOTING GUIDE

## WARNING

To avoid injury from an accidental start, turn the switch "OFF" and always remove the plug from the power source before making any adjustments.

- Consult your local Sears Service Center if for any reason the motor will not run.

SYMPTOM	POSSIBLE CAUSES	CORRECTIVE ACTION
Saw will not start.	<ol style="list-style-type: none"> <li>1. Saw not plugged in.</li> <li>2. Fuse blown or circuit breaker tripped.</li> <li>3. Cord damaged.</li> <li>4. Switch key not installed.</li> </ol>	<ol style="list-style-type: none"> <li>1. Plug in saw.</li> <li>2. Replace fuse or reset circuit breaker.</li> <li>3. Have cord replaced by a Sears Service Center.</li> <li>4. Refer to page 17, Figure X.</li> </ol>
Does not make accurate 45° and 90° rip cuts.	<ol style="list-style-type: none"> <li>1. Positive stop not adjusted correctly.</li> <li>2. Bevel angle pointer not set accurately.</li> </ol>	<ol style="list-style-type: none"> <li>1. Check blade with square and adjust positive stop.</li> <li>2. Position straight edge of wood against fence.</li> </ol>
Material pinched blade when ripping.	<ol style="list-style-type: none"> <li>1. Rip fence not aligned with blade.</li> <li>2. Warped wood, edge against fence is not straight.</li> </ol>	<ol style="list-style-type: none"> <li>1. Check and adjust rip fence.</li> <li>2. Select another piece of wood.</li> </ol>
Material binds on splitter.	<ol style="list-style-type: none"> <li>1. Splitter not aligned correctly with blade.</li> </ol>	<ol style="list-style-type: none"> <li>1. Check and align splitter with blade.</li> </ol>
Saw makes unsatisfactory cuts.	<ol style="list-style-type: none"> <li>1. Dull blade.</li> <li>2. Blade mounted backwards.</li> <li>3. Gum or pitch on blade.</li> <li>4. Incorrect blade for work being done.</li> <li>5. Gum or pitch on blade causing erratic feed.</li> </ol>	<ol style="list-style-type: none"> <li>1. Replace blade.</li> <li>2. Blade teeth must face forward.</li> <li>3. Remove blade and clean with turpentine and coarse steel wool.</li> <li>4. Change the blade.</li> <li>5. Clean table with turpentine and steel wool.</li> </ol>
Material kicked back from blade.	<ol style="list-style-type: none"> <li>1. Rip fence out of adjustment.</li> <li>2. Splitter not aligned with blade.</li> <li>3. Feeding stock without rip fence.</li> <li>4. Dull blade.</li> <li>5. Operator is letting go of material before it is past saw blade.</li> <li>7. Miter angle lock handle is not tight.</li> </ol>	<ol style="list-style-type: none"> <li>1. Align rip fence with miter gauge slot.</li> <li>2. Align splitter with blade.</li> <li>3. Install and use rip fence.</li> <li>4. Install and use splitter. (with guard)</li> <li>5. Replace blade.</li> <li>6. Push material all the way past saw blade before releasing work.</li> <li>7. Tighten handle.</li> </ol>
Blade does not raise or tilt freely.	<ol style="list-style-type: none"> <li>1. Sawdust and dirt in raising and tilting mechanisms.</li> </ol>	<ol style="list-style-type: none"> <li>1. Brush or blow out loose dust and dirt.</li> </ol>
Blade does not come up to speed.	<ol style="list-style-type: none"> <li>1. Extension cord too light or too long.</li> <li>2. Low house voltage.</li> </ol>	<ol style="list-style-type: none"> <li>1. Replace with adequate size cord.</li> <li>2. Contact your electric company.</li> </ol>
Machine vibrates excessively.	<ol style="list-style-type: none"> <li>1. Saw not mounted securely to workbench.</li> <li>2. Stand not level.</li> <li>3. Damaged saw blade.</li> </ol>	<ol style="list-style-type: none"> <li>1. Tighten all mounting hardware.</li> <li>2. Adjust stand level to floor.</li> <li>3. Replace blade.</li> </ol>
Does not make accurate 45° and 90° cross cuts.	<ol style="list-style-type: none"> <li>1. Miter gauge out of adjustment.</li> </ol>	<ol style="list-style-type: none"> <li>1. Square miter gauge to 90°.</li> </ol>

# PARTS LIST

10 in. TABLE SAW

MODEL NO. 137.248840

## ▲ WARNING

When servicing use only CRAFTSMAN replacement parts. Use of any other parts may create a HAZARD or cause product damage. Any attempt to repair or replace electrical parts on this Table Saw may create a HAZARD unless repair is done by a qualified service technician. Repair service is available at your nearest Sears Service Center.

### PARTS LIST FOR SAW SCHEMATIC

I.D. NO	Description	Size	Qty	I.D. NO	Description	Size	Qty
08VH	CLAMP-CORD		1	0KDR	CR. RE. PAN HD. SCREW	M5*0.8-10	1
09JK	WRENCH		1	0KF6	CR. RE. PAN HD. SCREW	M4*0.7-8	2
0AW4	BODY SHELL		1	0KHZ	CAP HD. SQ.NECK BOLT	M6*1.0-12	2
0B1W	HANDLE BAR ASS'Y		1	0KJ4	CAP HD. SQ.NECK BOLT	M6*1.0-35	1
0B23	SADDLE		1	0KJ5	CAP HD. SQ.NECK BOLT	M6X1.0-80	1
0B24	SPRING		1	0KMR	HEX. NUT	M5*0.8 T=4	1
0B27	POINTER BRACKET		1	0KMS	HEX. NUT	M6*1.0 T=5	1
0B2B	NEEDLE POINTER		1	0KMW	HEX. NUT	M10*1.5 T=8	1
0B2E	SWITCH BOX		1	0KMY	HEX. NUT	M10*1.5 T=4	1
0B3K	INSERT	#23	1	0KQJ	CROWN NUT	M8*1.25 T=6.5	1
0B3R	WRENCH		1	0KRX	HEX. NUT AND FLAT WASHER	M8*1.25 T=12.5	2
0B48	WARNING LABEL		1	0KSW	STRAIN RELIEF	M6*1.0	3
0B84	WASHER	D=φ18	1	0KWZ	LEAD WIRE ASS'Y		1
0B8A	WARNING STICK LABEL		1	0LMG	LOCKING CABLE TIE		1
0B99	SPACER		1	0LSL	CIRCUIT BREAKER SWITCH		1
0B9C	PLUNGER HOUSING		1	0LVJ	SWITCH KEY		1
0B9K	ANGLE ROD		1	0LWG	ROCKER SWITCH		1
0B9P	CLAMP		2	0QEF	MOTOR		1
0B9W	BRACKET		1	0S45	ROCKER SWITCH ELEMENT		1
0BA9	SPACER		2	0STE	HEIGHT REGULATING BOLT ASS'Y		1
0BAB	SHIM		1	0STF	PARRLE RING ASS'Y		1
0BAC	SET NUT		1	0SWY	HAND WHEEL ASS'Y		1
0BAE	ARBOR COLLAR	φ45	1	0SZY	SLIDING BASE ASS'Y		1
0BAT	NUT		1	0SZZ	SLIDING BASE ASS'Y		1
0BAU	SUPPORTING PLATE		1	0T00	SLIDING BASE ASS'Y		2
0BC2	LOCATION SEAT		5	0T03	SLIDING BASE ASS'Y		2
0BCW	UPPER TUBE		2	0T04	CLAMP ASS'Y		1
0BCX	EXTENTION WING		1	10GN	UPPER TUBE		1
0BPA	LOCK KNOB		1	10GP	UPPER TUBE		1
0J3U	WRENCH HEX.		1	10GQ	PARALLEL BRACKET ASS'Y		1
0J4F	FLAT WASHER	φ8X16-2.5	1	10GZ	SPACER		1
0J4H	FLAT WASHER	φ10*30-0.2	2	10H4	UPPER TUBE		1
0J5L	FLAT WASHER	φ5*10-0.3	10	10H5	UPPER TUBE		1
0J6T	FLAT WASHER	3/16*3/4-1/16	4	10H7	POWER CABLE ASS'Y		1
0J6U	FLAT WASHER	3/16*1/2-3/64	1	20KA	SCALE		1
0J6V	FLAT WASHER	3/16*3/8-0.022	8	20KC	SCALE		1
0J70	FLAT WASHER	1/4*3/4-7/64	1	20KD	SCALE		1
0J76	FLAT WASHER	1/4*3/4-1/16	2	20PM	DUST COLLECTOR		1
0J80	FLAT WASHER	5/32*13/32-3/64	2	20Q9	BAG-DUST		1
0J8D	FLAT WASHER	3/8*3/4-5/64	2	20WQ	HEX. HD. BOLT	M6*1.0-50	1
0J95	SPRING WASHER	φ6	1	20Z7	BLADE GUARD ASS'Y		1
0JAA	WASHER	φ8	1	2178	EXTENTION WING (RIGHT)	#AW	1
0JAE	EXTERNAL TOOTH LOCK WASHER	φ4	2	2179	EXTENTION WING (LEFT)	#AW	1
0JAF	EXTERNAL TOOTH LOCK WASHER	φ5	1	211Q	SCALE		1
0JE7	C-RING		1	211R	SCALE		1
0JED	C-RING		1	21BN	BRACKET GROUP ASS'Y		1
0JXL	HEX. SOC. SET SCREW	M10*1.5-12	1	21HH	MITER GAUGE ASS'Y		1
0K0Z	HEX. HD. SCREW AND WASHER	M8*1.25-16	4	23PP	BLADE		1
0K16	HEX. HD. SCREW AND WASHER	M8*1.25-16	1	27QV	DEFLECTOR		1
0K25	HEX.SOCKET HD.CAP SCREWS	M5*0.8-20	1	287H	RETAINING CLIP		1
0K3G	CR.RE. PAN HD. SCREW & WASHER	M5*0.8-12	1	29R2	WARNING LABEL		1
0K7K	CR. RE. ROUND WASHER HD. SCREW	M6*1.0-12	2	2AE5	WARNING LABEL		1
0K8C	CR. RE.COUNT HD. TAPPING SCREW	M4*1.8-10	4	2AE6	WARNING LABEL		1
0K9T	HEX. HD. TAPPING SCREW	M5*1.6-16	6	2ATR	TABLE	#AW	1
0K9U	HEX. HD. TAPPING SCREW	M5*1.6-25	8	2CWN	INSTRUCTIONS MANUAL		1
0KA4	CR.RE. PAN HD. TAPPING SCREW	M4*1.6-16	2	2CXG	LABEL		1
0KAP	CR.RE. PAN HD. TAPPING SCREW	M5*0.8-10	1	2CZK	BEVEL ANGLE ADJUSTMENT ASS'Y		1
0KC8	CR. RE. TRUSS HD. TAPPING SCREW	M4*1.6-16	2	2D6G	TRADE-MARK LABEL		1
0KCH	CR.RE. PAN HEAD TAPPING & WASHER SCREW	M5*0.8-12	2	Z00U	INSERT ASS'Y		1
0KCX	CR. RE. PAN HD PLAIN WASHER TAPPING SCREW	M5*0.8-10	2				



# 10 in. TABLE SAW

MODEL NO. 137.248840

## SCHEMATIC FOR SAW

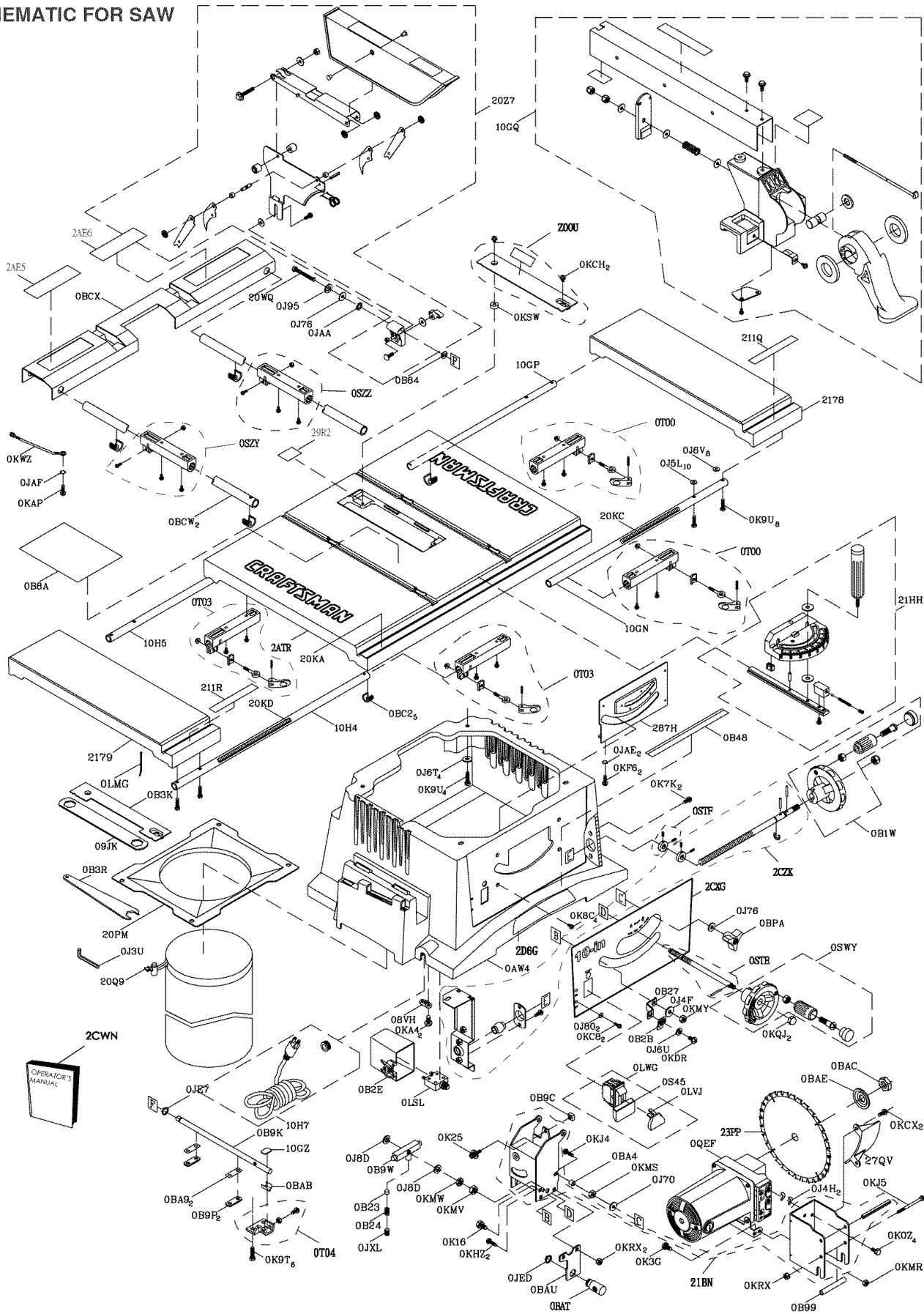

PARTS LIST AND SCHEMATIC FOR STAND

I.D. NO	Description	Size	QTY
09D6	FOOT PAD		4
0A4T	FENCE STORAGE CLIP		2
0EAA	BRACKET	#AW	4
0EAN	UPPER SUPPORT	#AW	1
0EAP	UPPER SUPPORT	#AW	1
0EAY	UPPER SUPPORT	#AW	2
0EB8	BOTTOM SUPPORT BRACKET	#AW	2
0EBG	BOTTOM SUPPORT BRACKET	#AW	2
0J4F	FLAT WASHER	φ8X16-2.5	4
0J4J	FLAT WASHER	φ10X20-2	4
0JPP	HEX. HD. BOLT	M8*1.25-30	4
0JPX	HEX. HD. BOLT	M10*1.5-20	4
0K7K	CR. RE. ROUND WASHER HD. SCREW	M6*1.0-12	2
0KMU	HEX. NUT	M10*1.5 T=8	4
0KRQ	SERRATED TOOTHED HEXAGON FLANGE NUT	M6*1.0 T=6	2
0KRR	SERRATED TOOTHED HEXAGON FLANGE NUT	M8*1.25 T=7.5	20
0Z1G	CAP HD. SQ. NECK BOLT	M8*1.25-12	16

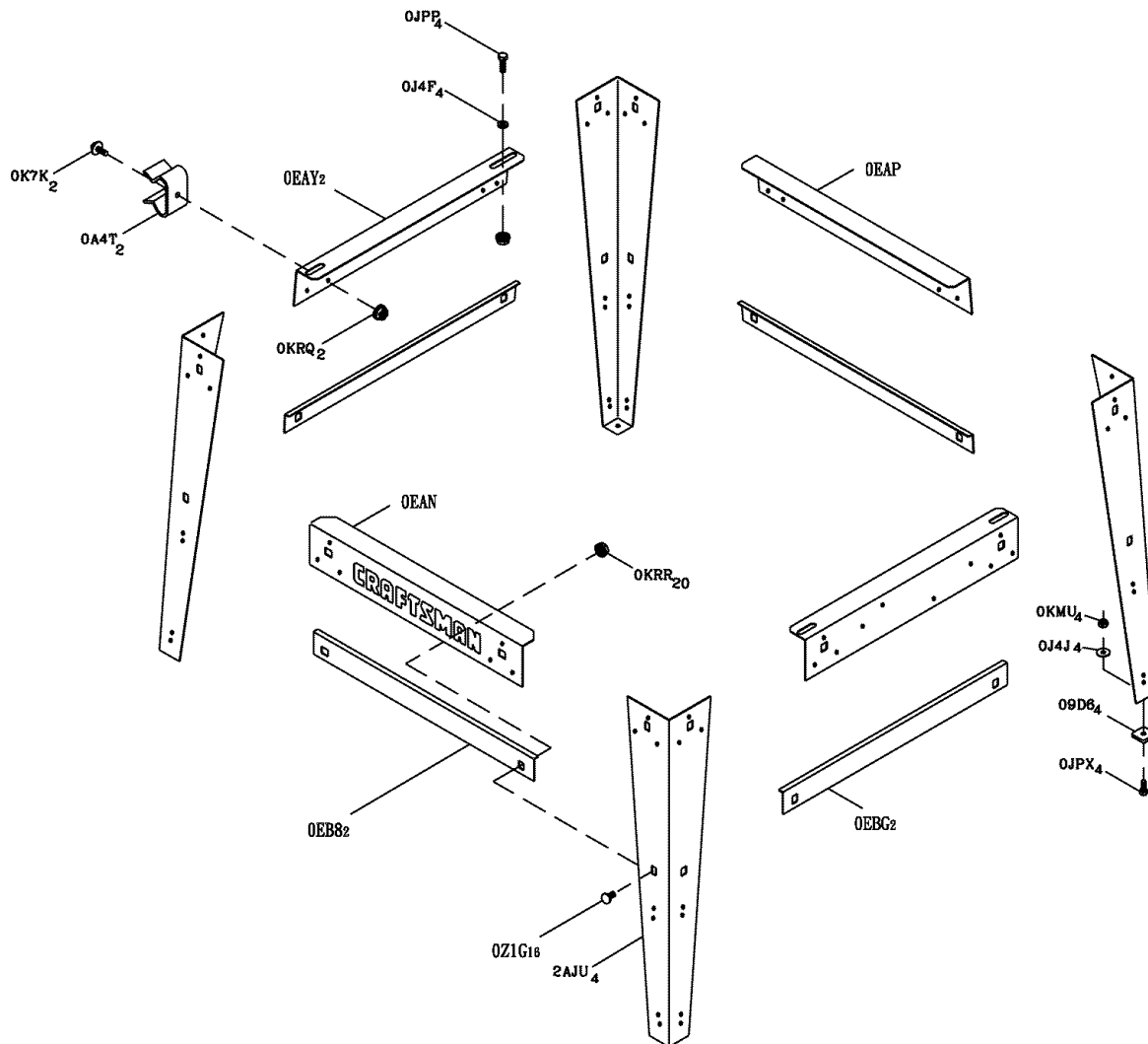

PARTS LIST AND SCHEMATIC FOR MOTOR

I.D. NO	Description	Size	Qty
0HV8	BALL BEARING	6201ZLU	1
0HVU	BALL BEARING	6200ZZ	1
0HX9	NEEDLE BEARING		1
0JAL	EXT.TOOTH LOCK WASHER	4	4
0JX3	HEX. SOC. SET SCREW	M5*0.8-8	2
0K3A	CR.RE. PAN HD. SCREW & WASHER	M5*0.8-30	4
0K5V	CR.-RE. COUND.HD.SCREW	M4*0.7-8	4
0KCP	CR.RE. PAN HEAD TAPPING & WASHER SCREW	M5*12-60	2
0KTH	STRAIN RELIEF		1
0QE9	MOTOR NAMEPLATE		1
0QEA	BRACKET		1
0QEC	ARBOR SHAFT ASS'Y		1
0QM2	BRUSH HOLDER ASS'Y		2
0QQT	BRUSH ASS'Y		2
0QR0	BRUSH COVER		2
0R1Q	MOTOR HOUSING		1
0R1S	BEARING BUSHING		1
0R1Y	ARMATURE ASS'Y		1
0R20	BAFFLE		1
1502	FIELD ASS'Y		1

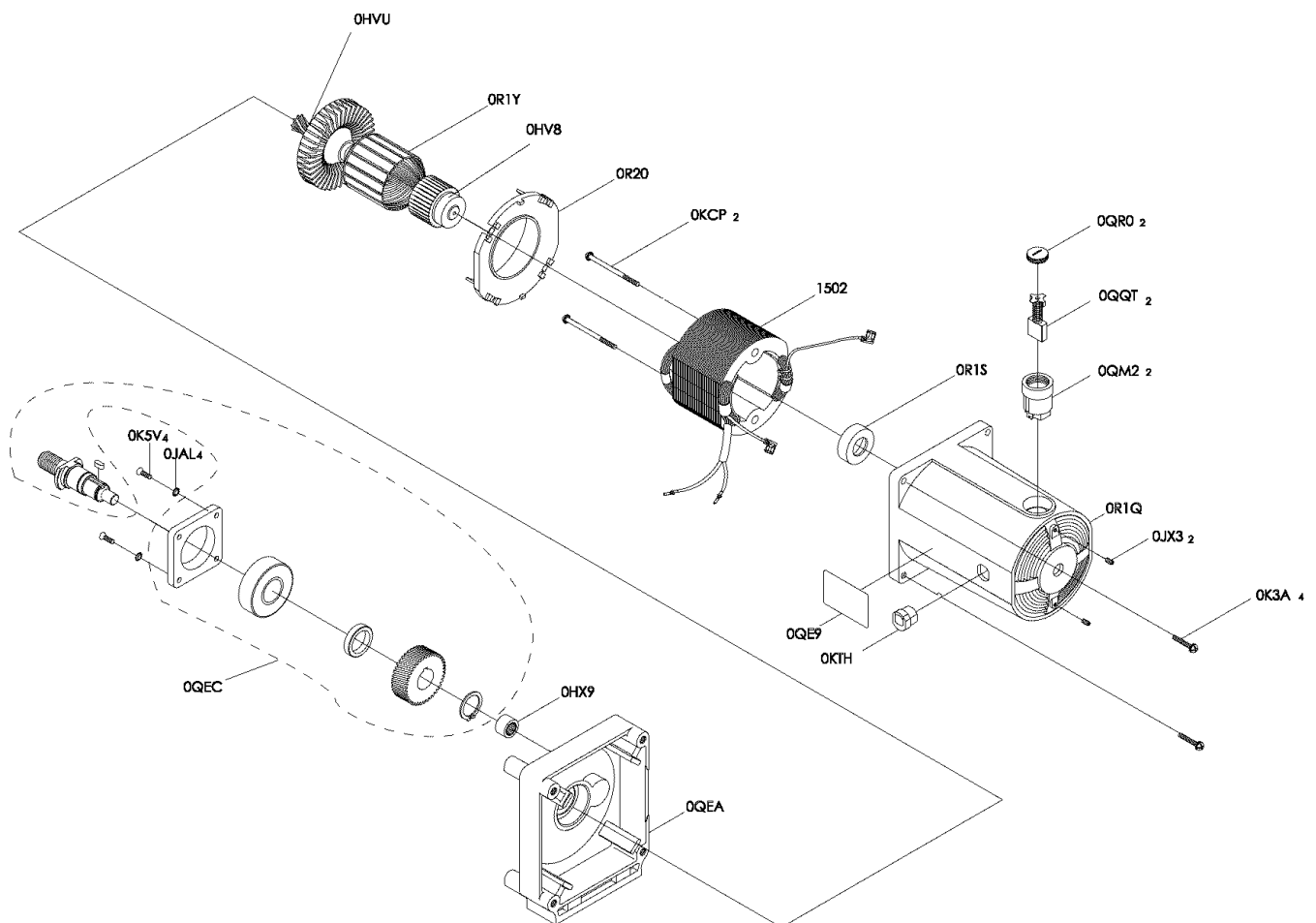

### PUSH STICK CONSTRUCTION

- This is a full-size drawing (actual size)
- Use good quality plywood or solid wood
- Use  $\frac{1}{2}$ " or  $\frac{3}{4}$ " material
- Push stick MUST be thinner than the width of material being cut

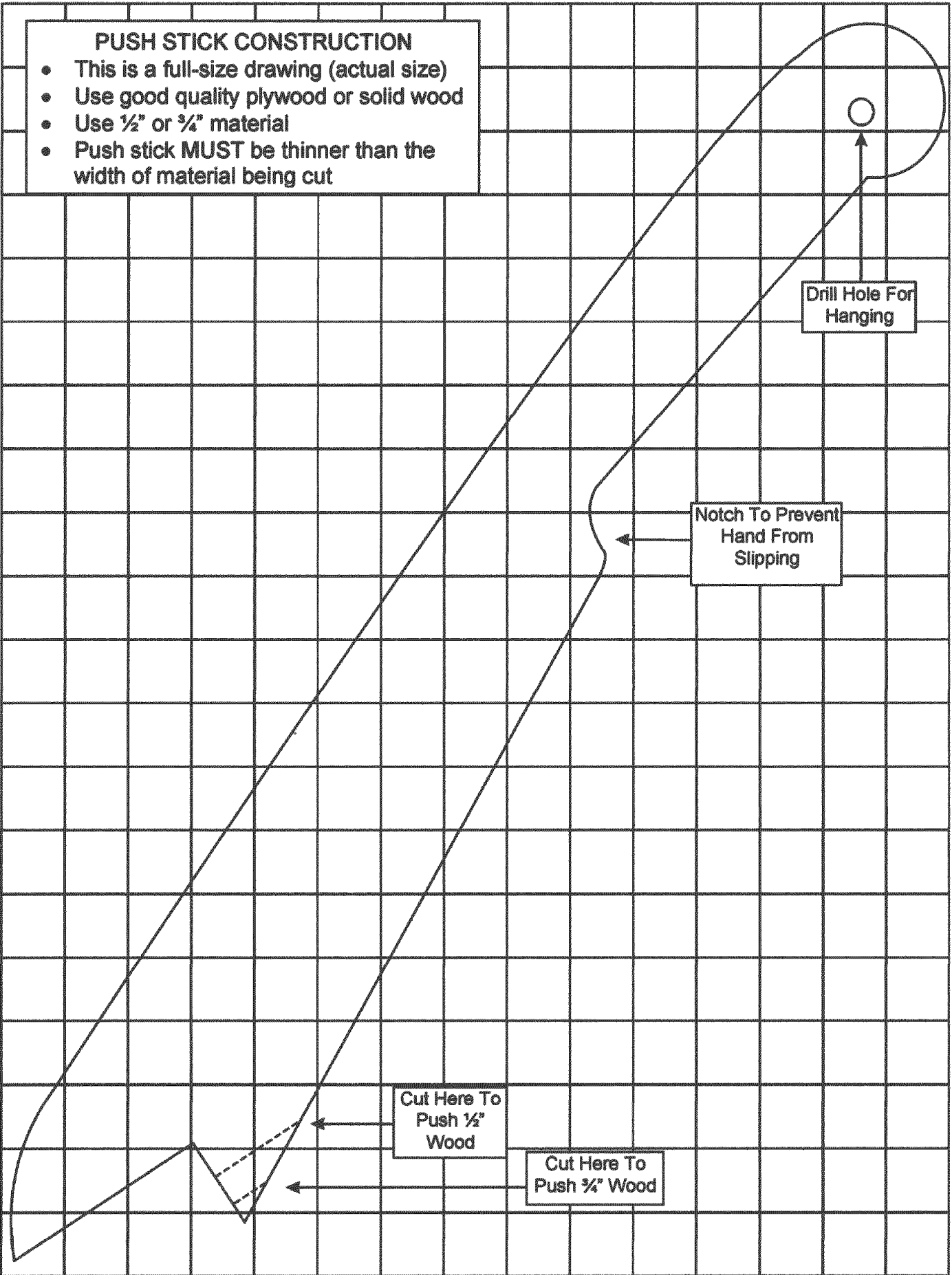

# NOTES

# Get it fixed, at your home or ours!

## Your Home

For repair – **in your home** – of all major brand appliances, lawn and garden equipment, or heating and cooling systems, **no matter who made it, no matter who sold it!**

For the replacement parts, accessories and Operator's Manuals that you need to do-it-yourself. For Sears professional installation of home appliances and items like garage door openers and water heaters.

**1-800-4-MY-HOME® (1-800-469-4663)**

Call anytime, day or night (U.S.A. and Canada)

[www.sears.com](http://www.sears.com)      [sears.ca](http://sears.ca)

## Our Home

For repair of carry-in items like vacuums, lawn equipment, and electronics, call or go on-line for the location of your nearest

**Sears Parts & Repair Center.**

**1-800-488-1222**

Call anytime, day or night (U.S.A. only)

[www.sears.com](http://www.sears.com)

To purchase a protection agreement on a product serviced by Sears:

**1-800-827-6655** (U.S.A.)

**1-800-361-6665** (Canada)

Para pedir servicio de reparación a domicilio, y para ordenar piezas:

**1-888-SU-HOGAR<sup>SM</sup>**

(1-888-784-6427)

Au Canada pour service en français:

**1-800-LE-FOYER<sup>MD</sup>**

**(1-800-533-6937)**

[sears.ca](http://sears.ca)

# SEARS

## Free Manuals Download Website

<http://myh66.com>

<http://usermanuals.us>

<http://www.somanuals.com>

<http://www.4manuals.cc>

<http://www.manual-lib.com>

<http://www.404manual.com>

<http://www.luxmanual.com>

<http://aubethermostatmanual.com>

Golf course search by state

<http://golfingnear.com>

Email search by domain

<http://emailbydomain.com>

Auto manuals search

<http://auto.somanuals.com>

TV manuals search

<http://tv.somanuals.com>