

Owner's Manual

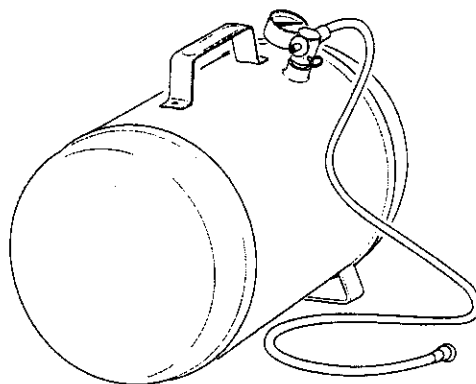

Portable Air Tank



Model No. 15200/15201

ONE YEAR FULL WARRANTY ON CRAFTSMAN PORTABLE AIR TANK

If this Craftsman Portable Air Tank fails due to manufacturer's defects in material or workmanship within one year from the date of purchase, return it to your nearest Sears store in the United States and it will be replaced free of charge.

If this Portable Air Tank is used for commercial or rental purposes, this warranty applies for only 90 days from the date of purchase. This warranty gives you specific legal rights and you may also have other rights which vary from state to state.

Sears, Roebuck and Co., Dept. 817WA, Hoffman Estates, IL 60179

Important Safety Instructions and Guidelines

⚠ WARNING The information listed below should be read and understood by the operator. This information is given to protect the user while operating and storing the portable air tank. We use the symbols below to allow the reader to recognize important safety information. Improper operation or maintenance of this product could result in serious injury and/or property damage. Read and understand all of the warnings and safety instructions provided before using this equipment.

⚠ WARNING

Indicates a potentially hazardous situation which, if not avoided, could result in death or serious injury.

Risk to Breathing

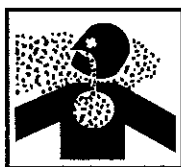

Keep children, pets, and others out of the area of operation. This portable air tank does not provide breathable air for anyone or any auxiliary breathing device.

Risk of Bursting



If the tank develops a leak, then replace the portable air tank. Never attempt to repair a tank by welding!
NOTE: Discard the empty tank and DO NOT use after 7 years from the date purchased from Sears by the original owner. This tank is stamped with a "DISCARD AFTER" date if date is unknown.

Risk of Personal Injury

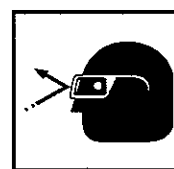

Compressed air can be hazardous. The air stream can cause injury to soft tissue areas such as eyes, ears, etc. Particles or objects propelled by the air stream can cause injury.

Operating Procedures

Filling the Portable Air Tank

Take your portable air tank to any source of clean dry compressed air. A full service gas station or truck stop is preferable. Modern convenience mart type filling stations do not have sufficient air pressure available to allow you to get the most from your air tank. It is recommended that you fill your tank with air until the pressure gauge reads between 95 to 135 psi. The air tank is filled like a car tire by pressing the chuck from the source to the filler valve. **PLEASE NOTE: Tank can be filled and the pressure gauge can be read with the RED ON/OFF KNOB in the OFF position.**

Using the Portable Air Tank

Turn the RED ON/OFF KNOB counter-clockwise to the open position to allow air to flow from the tank into the hose. To prevent air from leaking out of the tank between uses, turn the RED ON/OFF KNOB clockwise to the closed position.

Storage

STORING YOUR PORTABLE AIR TANK

Turn the RED ON/OFF KNOB CLOCKWISE to the OFF position when storing your air tank.

⚠ WARNING

Failure to remove condensation will cause the tank to rust prematurely.

Always drain the tank of all air after the last use for the day and before repairing or removing any component parts. Point the safety pressure relief valve AWAY FROM YOUR BODY when releasing air. Use the pull ring on the safety relief valve to vent any pressure inside the tank before attempting to service the tank. Safety goggles must be worn at all times for eye protection. To disperse any accumulated condensation inside the tank, begin by reducing the air pressure inside the tank by pulling out on the safety valve and holding until the tank gauge reaches 25 psi. Invert the tank with the manifold facing downward and pull the ring on the safety relief valve. We as the manufacturer and you as the consumer have no control over the moisture content of air coming from any fill source. Premature rusting caused by condensation inside the tank is the primary reason for the suggested replacement date stamped on the tank.

- Never attempt to remove any components while tank is pressurized.
- Never remove or deface the information sticker on tank.
- Never attempt to fill the tank if any air leak is detected in the tank body. Discontinue use of the air tank immediately.
- Warranty is void if any attempt is made to alter or

Parts List

- ① Carry Handle
- ② Pressure Gauge
Indicates internal air pressure of tank.
- ③ On/Off Valve
Prevents air from leaking out of the air hose and/or tire chuck, when in the off position.
- ④ Filler Valve
Fill tank with compressed air through this point.
- ⑤ Safety Pressure Relief Valve
Prevents tank from being over-pressurized.
- ⑥ Air Hose
Delivers compressed air from the tank.
- ⑦ Steel Legs
Support tank in an upright stable position.
- ⑧ Tire Chuck
Used to inflate tires and other items.

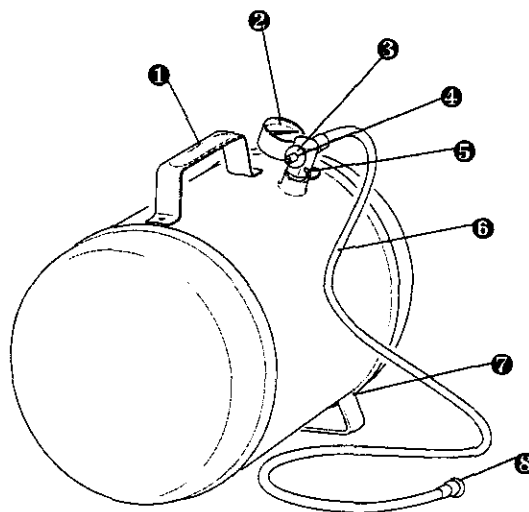

Manifold Enlargement

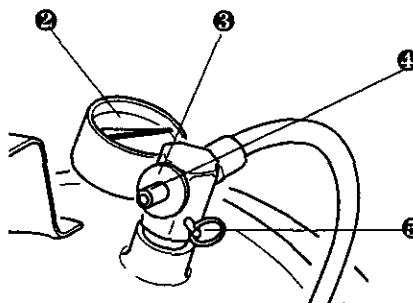

Replacement Parts

Item No(s).	Part No.	Description	Qty.
2	E100179	Pressure Gauge	1
3, 4, & 5	E100177	Manifold Assembly	1
6 & 8	E100178	Air Hose w/Chuck	1

For replacement parts call
1-800-4-MY-HOME® (1-800-469-4663)

Free Manuals Download Website

<http://myh66.com>

<http://usermanuals.us>

<http://www.somanuals.com>

<http://www.4manuals.cc>

<http://www.manual-lib.com>

<http://www.404manual.com>

<http://www.luxmanual.com>

<http://aubethermostatmanual.com>

Golf course search by state

<http://golfingnear.com>

Email search by domain

<http://emailbydomain.com>

Auto manuals search

<http://auto.somanuals.com>

TV manuals search

<http://tv.somanuals.com>