

Owner's Manual



19" Mulching/Rear Discharge

PUSH LAWN MOWER

Model No.
247.388250

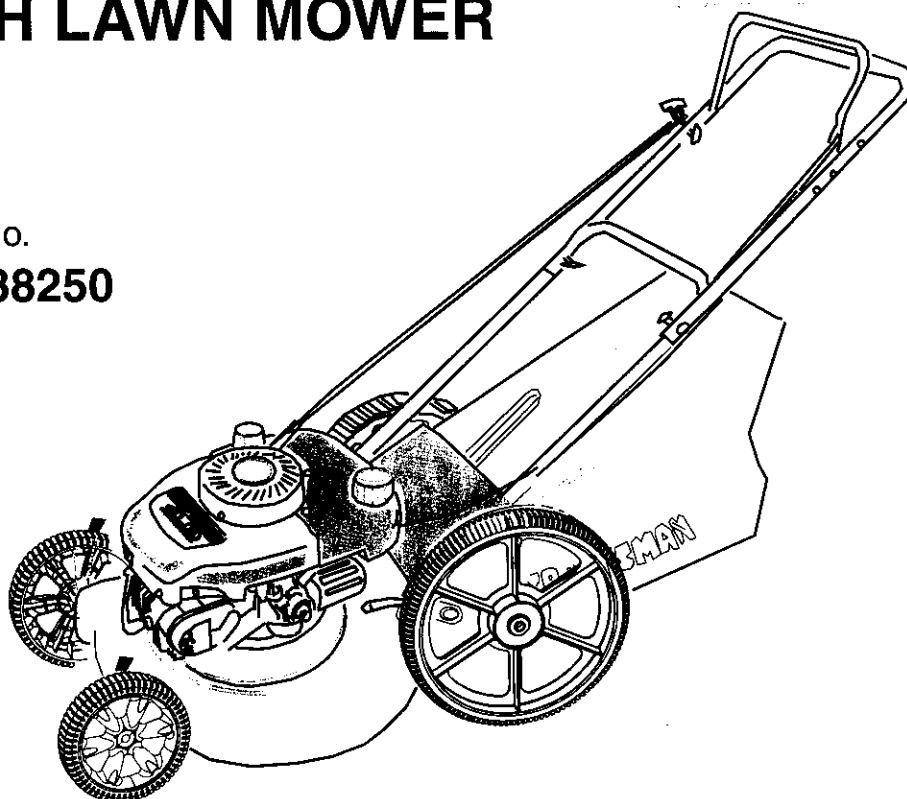

CAUTION: Before using this product, read this manual and follow all safety rules and operating instructions.

- Safety
- Assembly
- Operation
- Service
- Maintenance
- Español

Sears, Roebuck and Co., Hoffman Estates, IL 60179, U.S.A.

Visit our Sears website: www.sears.com/craftsman

TABLE OF CONTENTS

Content	Page	Content	Page
Warranty Information	2	Service & Adjustment.....	15
Safe Operation Practices	3	Storage	17
Slope Gauge	6	Trouble-Shooting	19
Assembly	7	Parts List.....	20
Operation	9	Espanól.....	26
Maintenance	12		

WARRANTY INFORMATION

Two-Year Warranty on Craftsman Lawn Mower

For two years from the date of purchase, when this Craftsman lawn mower is maintained, lubricated, and tuned up according to the instructions in the owner's manual, Sears will repair, free of charge, any defects in material or workmanship. If this lawn mower is used for commercial or rental purposes, this warranty applies for only 90 days from the date of purchase.

This warranty does not cover:

1. Expendable items which become worn during normal use, such as rotary mower blades, blade adapters, belts, air cleaners and spark plug.
2. Repairs necessary because of operator abuse or negligence, including bent crankshafts and the failure to maintain equipment according to the instructions contained in the owner's manual.

WARRANTY SERVICE IS AVAILABLE BY RETURNING THE CRAFTSMAN LAWN MOWER TO THE NEAREST SEARS SERVICE CENTER IN THE UNITED STATES. THIS WARRANTY APPLIES ONLY WHILE THIS PRODUCT IS IN USE IN THE UNITED STATES.

This warranty gives you specific legal rights, and you may also have other rights which vary from state to state.
Sears, Roebuck and Co., D/817WA, Hoffman Estates, IL 60179

PRODUCT SPECIFICATIONS	
Horsepower:	4.0
Engine Oil	21 oz. SAE 30 oil
Fuel Capacity:	1.5 quarts
Spark Plug	J19LM Gap .030 inches

<p>Please record model number, serial number, and date of purchase of the lawn mower here for future reference. You will find this information on the model plate located on the mower cutting deck.</p> <p>Model Number</p> <p>Serial Number.....</p> <p>Date of Purchase</p>
--

SAFE OPERATION PRACTICES



This symbol points out important safety instructions which, if not followed, could endanger the personal safety and/or property of yourself and others. Read and follow all instructions in this manual before attempting to operate your lawn mower. Failure to comply with these instructions may result in personal injury. When you see this symbol—**heed its warning.**



DANGER:

Your lawn mower was built to be operated **according to the rules for safe operation in this manual.** As with any type of power equipment, carelessness or error on the part of the operator can result in serious injury. **If you violate any of these rules, you may cause serious injury to yourself or others.**



This unit is equipped with an internal combustion engine and should not be used on or near any unimproved forest-covered, brush-covered or grass-covered land unless the engine's exhaust system is equipped with a spark arrester meeting applicable local or state laws (if any). If a spark arrester is used, it should be maintained in effective working order by the operator.

In the State of California the above is required by law (Section 4442 of the California Public Resources Code). Other states may have similar laws. Federal laws apply on federal lands. A spark arrester for the muffler is available through your nearest Sears Authorized Service Center (See the REPAIR PARTS section of this manual.)



WARNING: The engine exhaust from this product contains chemicals known to the State of California to cause cancer, birth defects or other reproductive harm.

GENERAL OPERATION

- Read this owner's guide carefully in its entirety before attempting to assemble this machine. Read, understand, and follow all instructions on the machine and in the manual(s) before operation. Be completely familiar with the controls and the proper use of this machine before operating it. Keep this manual in a safe place for future and regular reference, and for ordering replacement parts.
- Your rotary mower is a precision piece of power equipment, not a plaything. Therefore, exercise extreme caution at all times. Your unit has been designed to perform one job: to mow grass. Do not use it for any other purpose.
- Never allow children under 14 years old to operate a power mower. Children 14 years old and over should only operate mower under close parental supervision. Only responsible individuals who are familiar with these rules of safe operation should be allowed to use your mower.
- Keep the area of operation clear of all persons, particularly small children and pets. Stop engine when they are in the vicinity of your mower to help prevent blade contact or thrown object injury. Although the area of operation should be completely cleared of foreign objects, an object may have been overlooked and could be accidentally thrown by the mower in any direction and cause serious personal injury to the operator or any others allowed in the area.
- Thoroughly inspect the area where the equipment is to be used. Remove all stones, sticks, wire, bones, toys and other foreign objects which could be picked up and thrown by the mower in any direction and cause serious personal injury to the operator or any others allowed in the area. Plan your mowing pattern to avoid discharge of material toward roads, sidewalks, bystanders and the like. To help avoid a thrown object's injury, keep children, bystanders and helpers at least 75 feet from the mower while it is in operation.
- Always wear safety glasses or safety goggles during operation or while performing an adjustment or repair, to protect eyes from foreign objects that may be thrown from the machine in any direction.
- Wear sturdy, rough-soled work shoes and close-fitting slacks and shirts. Shirts and pants that cover the arms and legs and steel-toed shoes are recommended. Do not wear loose fitting clothes or jewelry. They can be caught in moving parts. Never operate a unit in bare feet, sandals, slippery or light weight (e.g. canvas) shoes.
- Do not put hands or feet near or under rotating parts. Keep clear of discharge opening at all times as the rotating blade can cause injury.
- Many injuries occur as a result of the mower being pulled over the foot during a fall. Do not hang on to the mower if you are falling; release the handle immediately.
- Never pull the mower toward you while you are walking. If you must back the mower away from a

wall or obstruction first look down and behind, and then follow these steps:

- a. Step back from the mower to fully extend your arms.
 - b. Be sure you are well balanced with sure footing.
 - c. Pull the mower back slowly, no more than half way toward you.
 - d. Repeat these steps as needed.
- Do not operate the mower while under the influence of alcohol or drugs.
 - Do not engage the self-propelled mechanism on units so equipped while starting engine.
 - The blade control handle is a safety device. Never attempt to bypass its operation. Doing so makes the safety device inoperative and may result in personal injury through contact with the rotating blade. The blade control handle must operate easily in both directions and automatically return to the disengaged position when released.
 - Never operate the mower in wet grass. Always be sure of your footing. A slip and fall can cause serious personal injury. Keep a firm hold on the handle and walk, never run. If you feel you are losing your footing, **RELEASE THE BLADE CONTROL HANDLE IMMEDIATELY** and the blade will stop rotating within three seconds.
 - Mow only in daylight or good artificial light.
 - Stop the blade when crossing gravel drives, walks or roads.
 - If the equipment should start to vibrate abnormally, stop the engine and check immediately for the cause. Vibration is generally a warning of trouble.
 - Shut the engine off and wait until the blade comes to a complete stop before removing the grass catcher or unclogging the chute. The cutting blade continues to rotate for a few seconds after the engine is shut off. Never place any part of the body in the blade area until you are sure the blade has stopped rotating.
 - Never operate mower without proper guards, grass catcher, plates or other safety protective devices in place.
 - Muffler and engine become hot and can cause a burn. Do not touch.
 - Do not adjust the throttle control with the engine running.
 - Only use accessories approved for this machine by the manufacturer. Read, understand, and follow all instructions provided with the approved accessory.
 - If situations occur which are not covered in this manual, use care and good judgment. Contact your dealer for assistance.

Slope Operation

For your safety, use the slope gauge included as part of this manual to measure slopes before operating this unit on a slope or hilly area. If the slope is greater than 15 degrees

as shown on the slope gauge (page 6), do not operate this unit on that area or serious injury could result.

DO:

- Mow across the face of slopes; never up and down. Exercise extreme caution when changing direction on slopes.
- Watch for holes, ruts, hidden objects, or bumps. Tall grass can hide obstacles.
- Always be sure of your footing. A slip and fall can cause serious personal injury. If you feel you are losing your balance release the blade control handle immediately and the blade will stop in less than 3 seconds.
- **ON MODELS WITH CASTER WHEELS:** Lock both front wheels so they do not pivot while mowing on the face of slopes. To turn the mower, depress the handle and raise the front wheels slightly.

DO NOT:

- Do not mow near drop-offs, ditches or embankments. The operator could lose footing or balance.
- Do not mow slopes greater than 15 degrees as shown on the slope gauge.
- Do not mow on wet grass. Reduced footing could cause slipping.
- **ON MOWERS WITH CASTER WHEELS:** Do Not mow on slopes with casters unlocked since the mower has a tendency to drift down hill.

Children

Tragic accidents can occur if the operator is not alert to the presence of children. Children are often attracted to the mower and the mowing activity. Never assume that children will remain where you last saw them.

- Keep children out of the mowing area and under the watchful care of a responsible adult other than the operator.
- Be alert and turn mower off if a child enters the area.
- Before and while moving backwards, look behind and down for small children or other objects.
- Never allow children under age 14 to operate the mower. Children 14 years of age and above should read and understand the operation instructions and safety rules in this manual.
- Use extreme care when approaching blind corners, shrubs, trees, or other objects that may obscure your vision of a child or hazard.

Service

- Use extreme care in handling gasoline and other fuels. They are extremely flammable and the vapors are explosive.
- Use only an approved gasoline container.
- Never remove gas cap or add fuel while the engine is running. Allow engine to cool at least two minutes before refueling.

- Replace gasoline cap securely and wipe off any spilled gasoline before starting the engine as it may cause a fire or explosion.
- Extinguish all cigarettes, cigars, pipes and other sources of ignition.
- Never refuel machine indoors because flammable vapors will accumulate in the area.
- Never store the machine or fuel container inside where there is an open flame or spark such as a gas water heater, space heater, or furnace.
- Never run an engine inside a closed area.
- To reduce fire hazard, keep mower free of grass, leaves, or other debris build-up. Clean up oil or fuel spillage. Allow mower to cool at least 5 minutes before storing.
- Before cleaning, repairing, or inspecting, make certain the blade and all moving parts have stopped. Disconnect the spark plug wire, and keep the wire away from the spark plug to prevent accidental starting.
- Check the blade and engine mounting bolts at frequent intervals for proper tightness. Also, visually inspect blade for damage (e.g., bent, cracked or worn). Replace with blade which meets original equipment specifications listed in this manual.
- Keep all nuts, bolts, and screws tight to be sure the equipment is in safe working condition.
- Never tamper with safety devices. Check their proper operation regularly.
- After striking a foreign object, stop the engine, remove the wire from the spark plug, and thoroughly inspect the mower for any damage. Repair the damage before starting and operating the mower.
- Never attempt to make a wheel or cutting height adjustment while the engine is running.
- Grass catcher components are subject to wear, damage and deterioration, which could expose moving parts or allow objects to be thrown. For safety protection, frequently check components and replace with manufacturer's recommended parts, when necessary.
- Mower blades are sharp and can cut. Wrap the blade(s) or wear gloves, and use extra caution when servicing them.
- Do not change the engine governor setting or overspeed the engine. Excessive engine speeds are dangerous.

YOUR RESPONSIBILITY



Restrict the use of this power machine to persons who read, understand and follow the warnings and instructions in this manual and on the machine.

Following are representations of two of the safety labels on your lawn mower. Maintain safety while operating the mower. Over prolonged use of the mower, these labels may become hard to read and should be replaced.



SAVE THESE INSTRUCTIONS FOR FUTURE REFERENCE.

SLOPE GAUGE

USE THIS PAGE AS A GUIDE TO DETERMINE SLOPES WHERE YOU MAY NOT OPERATE SAFELY:

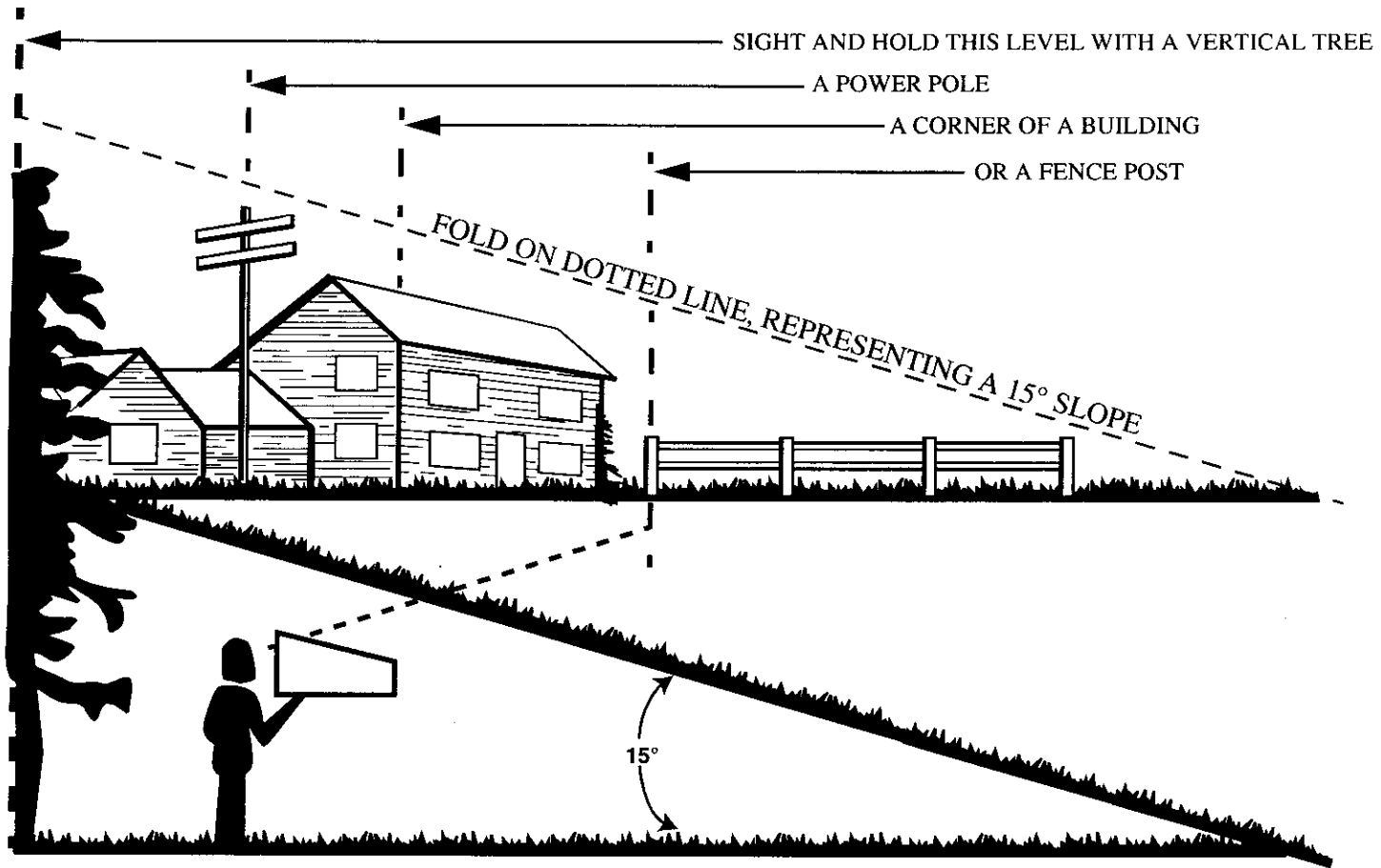

WARNING

Do not mow on inclines with a slope in excess of 15 degrees (a rise of approximately 2-1/2 feet every 10 feet). A riding mower could overturn and cause serious injury. If operating a walk-behind mower on such a slope, it is extremely difficult to maintain your footing and you could slip, resulting in serious injury. Operate RIDING mowers up and down slopes, never across the face of slopes. Operate WALK-BEHIND mowers across the face of slopes, never up and down slopes.

ASSEMBLY

Removing Unit From Carton

- Remove staples, break glue on top flaps, or cut tape at carton end and peel along top flap to open carton.
- Remove owner's manual from the carton.
- Remove any loose parts, if included with unit. See Figure 1.

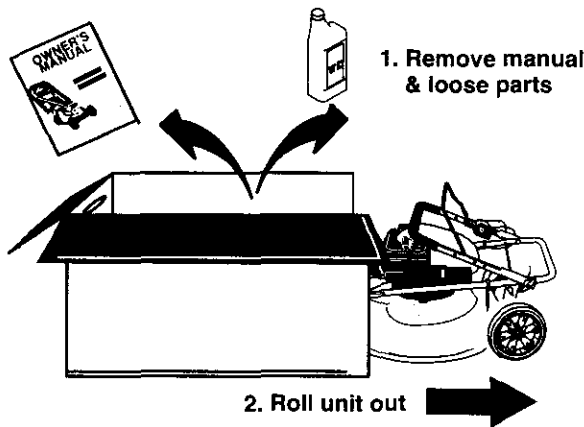

Figure 1

- Cut along dotted lines and lay carton down flat.
- Remove packing material.
- Roll or slide unit out of carton. See Figure 1. Check carton thoroughly for loose parts.

Note: Make sure not to crimp the cable while removing unit or parts from the carton.

IMPORTANT: This unit is shipped **without gasoline or oil in the engine**. Be certain to service engine with gasoline and oil before operating your mower.

NOTE: Reference to right or left hand side of the mower and/or front or behind the mower is observed from the operating position.

Loose Parts

- a. Owner's Manual
- b. A Bottle of Engine Oil
- c. Grass Catcher

Disconnecting Spark Plug

- Before setting up your lawn mower, disconnect the spark plug wire from the spark plug, and

ground it against the post on the engine. See Figure 2.

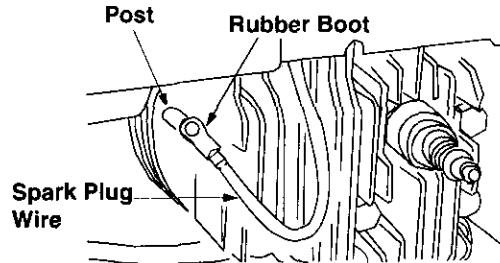

Figure 2

Assembling Handle

- Remove carriage bolt and wing nut from the lower handle. See Figure 3. Repeat on the other side.

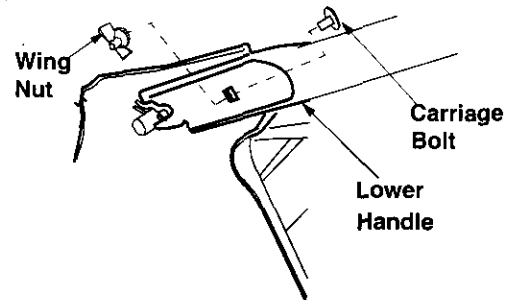

Figure 3

- Raise the lower handle in the direction A shown in Figure 4. The lower handle should snap into place.

Note: Make sure to route the cable inside the lower handle. Also do not crimp the cable while lifting the handle up.

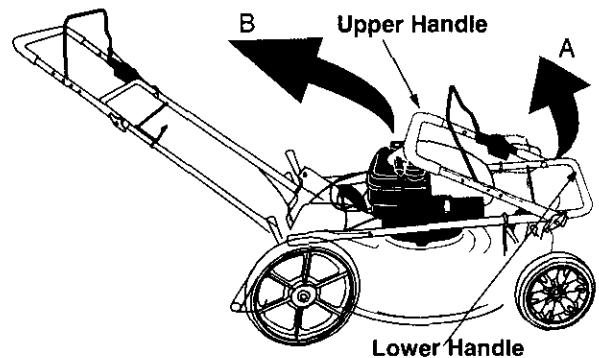

Figure 4

- Reinsert carriage bolt in the upper hole of the handle bracket and the lower handle as shown in Figure 3.

- Secure with wing nut. Repeat on other side.
- Raise the upper handle in the direction B shown in Figure 4. Tighten the wing nuts which are already on the handle.
- Route the control cable to the inside of the lower handle.
- Attach control cable to the lower handle with the two cable ties provided on the lower handle. Place posts on cable ties into the holes on the lower handle as shown below. Pull the cable ties tight and cut off extra. See Figure 5.

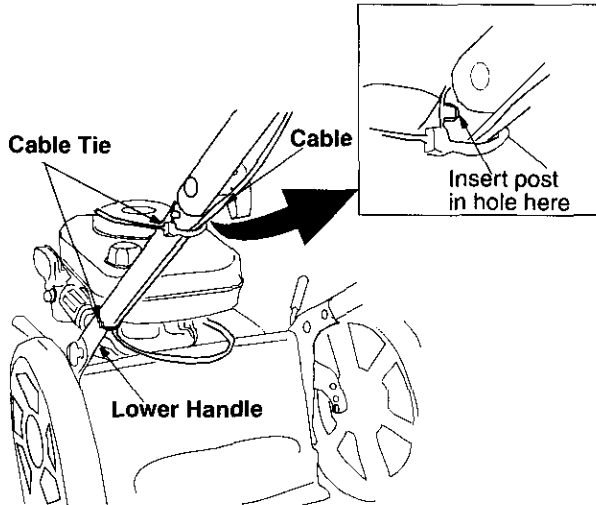

Figure 5

Mulching Plug

Your lawn mower was shipped with the mulching plug already installed on the unit. If you want to mulch the lawn, leave it in place. For bagging purposes, remove the mulching plug and attach the grass catcher to the mower. Follow directions to remove the mulching plug.

- Lift the chute door on the mower. Remove the mulching plug as shown in Figure 6.

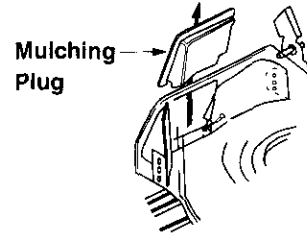

Figure 6

Attaching Grass Catcher to Mower

- Holding the grass bag firmly, place the bag on the mower as shown in Figure 7.

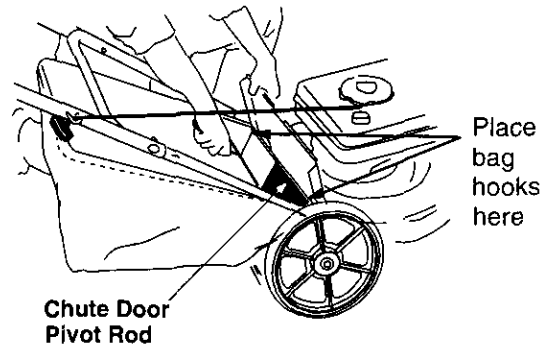

Figure 7

- Place hooks, located on two sides of the grass catcher frame, over the chute door pivot rod on the back of the unit. See Figure 7. Release the chute door.



Warning: Never operate the mower unless the grass catcher frame is firmly seated on the chute door pivot rod, rear discharge door rests firmly on top of the grass catcher or the mulch plug is securely installed.

OPERATION

Know Your Lawn Mower

Read this owner's manual and safety rules before operating your lawn mower. Compare the illustrations in Figure 8 with your lawn mower to familiarize yourself with the location of various controls and adjustments. Save this manual for future reference.



WARNING: The operation of any lawn mower can result in foreign objects being thrown into the operator's eyes and causing severe eye damage. **Always wear safety glasses** while operating the mower, or while performing any adjustments or repairs on it.

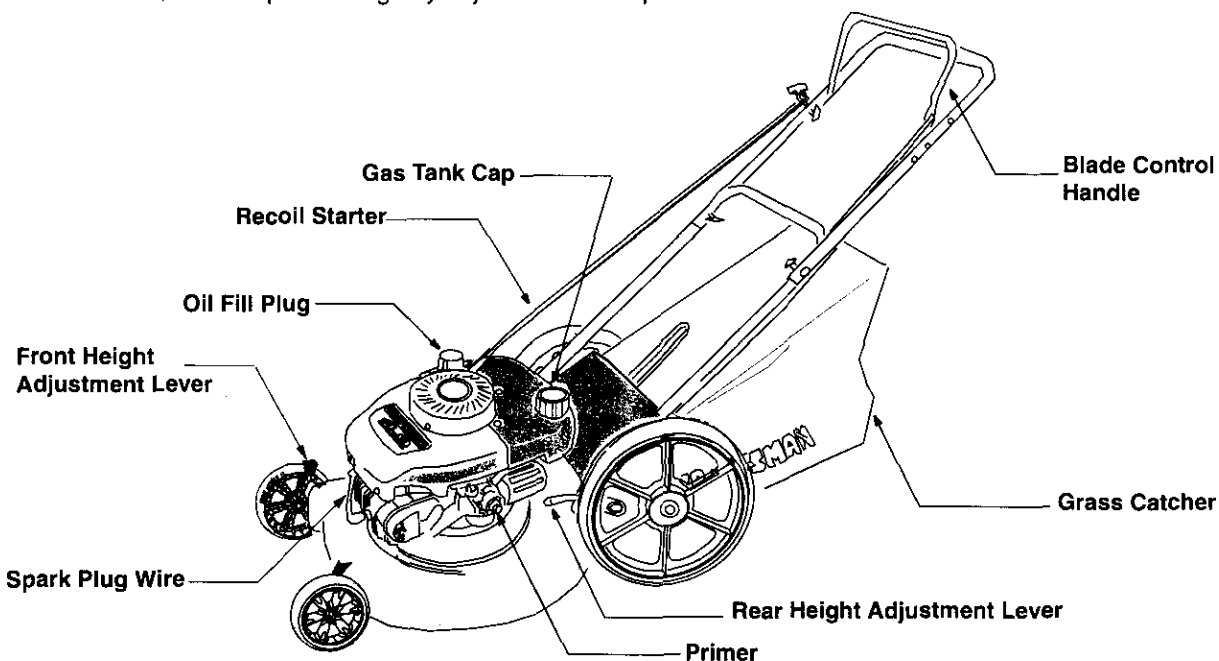

Figure 8

Recoil Starter

The recoil starter is attached to the handle. Stand behind the unit and pull the recoil starter to start the unit.

Primer

The primer is used to pump gas into the carburetor. Use it to start a cold engine, but do not use it to restart a warm engine after short shutdown.

Blade Control Handle

The blade control handle is located on the upper handle of the mower. The blade control handle must be depressed in order to operate the unit. Release blade control handle to stop engine and blade.



WARNING: This blade control mechanism is a safety device. **Never attempt to bypass** its operations.

Height Adjustment Lever

These levers are located on each wheel and are used to adjust the cutting height. All four levers have to be at the same relative position to ensure uniform cut.

Engine Speed

Your mower's engine speed has been set at the factory. Do not attempt to increase engine speed or it may result in personal injury. If you think that the engine is running too fast or too slow, take your unit to a Sears service center near you.

Meets CPSC Blade Safety Standards

Craftsman Walk-Behind Lawn Mowers conform to the safety standards of the American National Standards Institute and the U.S. Consumer Product Safety Commission.

Stopping Engine

- Release blade control handle to stop the engine and the blade.
- Disconnect and ground the spark plug wire to prevent accidental starting.



WARNING: Before using your lawn mower, again refer to the **safety rules** on pages 3-5 of this manual. **Always be careful.**

Gas And Oil Fill-Up

Engine Oil

Only use high quality detergent oil rated with API service classification SF, SG or SH. Select the oil's viscosity grade according to your expected operating temperature. Follow the chart below.

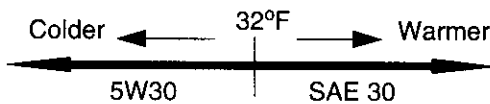

Oil Viscosity Grade Chart

- Use SAE30 oil; *do not use* 10W40 oil.
- Fill oil sump and check the oil level as follows:
 - a. Position the mower on level ground.
 - b. Clean area around oil fill plug.
 - c. Remove oil fill plug and dipstick.
 - d. Wipe dipstick clean, insert it into oil fill hole and tighten securely.
 - e. Remove dipstick and check oil level. If the oil is not up to FULL mark on the dipstick, pour recommended oil through the oil fill and check the level again.
- Install oil fill plug and dipstick, tighten securely.

NOTE: Although multi-viscosity oils (5W30, 10W30, etc.) improve starting in cold weather, these multiviscosity oils will result in increased oil consumption when used above 32°F. Check the oil level more frequently to avoid possible engine damage from running low on oil.

Gasoline



WARNING: Never fill fuel tank indoors, or when engine is running or hot. Do not smoke when filling fuel tank.

IMPORTANT: Never mix engine oil with gasoline.

- Clean area around gas tank cap. For location of gas tank cap, see Figure 9. Remove cap.
- Use a funnel to prevent spillage.
- Pour approximately 1.5 quarts of fresh, regular grade, unleaded gasoline slowly to the fuel tank.
- Fill tank to 1/2" below the bottom of the filler neck. Wipe any fuel spillage. **Do not fill** fuel tank completely. Provide space for fuel expansion.

Starting Engine

(Refer to Figure 9.)



WARNING: Be sure **no one other than the operator** is standing near the lawn mower while starting or operating.

- Attach spark plug wire and ground to post on engine. Make certain the metal cap on the end of the spark plug wire is fastened securely over the metal tip on the spark plug. See Figure 2.



WARNING: Never run engine indoors or in enclosed, poorly ventilated areas. Engine exhaust contains carbon monoxide, an odorless and deadly gas.

WARNING: Keep hands, feet, hair and loose clothing away from any moving parts on engine and lawn mower.

- Push primer five times. Wait about two seconds between each push. **Do not prime to restart a warm engine** after a short shutdown.
- Hold blade control handle against the upper handle. Grasp recoil starter and pull rope out slowly until engine reaches the start of compression cycle (rope will pull slightly harder at this point). See Figure 9 inset. Let the rope rewind slowly.
- Pull rope with a rapid, continuous, full arm stroke. Keeping a firm grip on the recoil starter, let the rope return to the starter slowly.

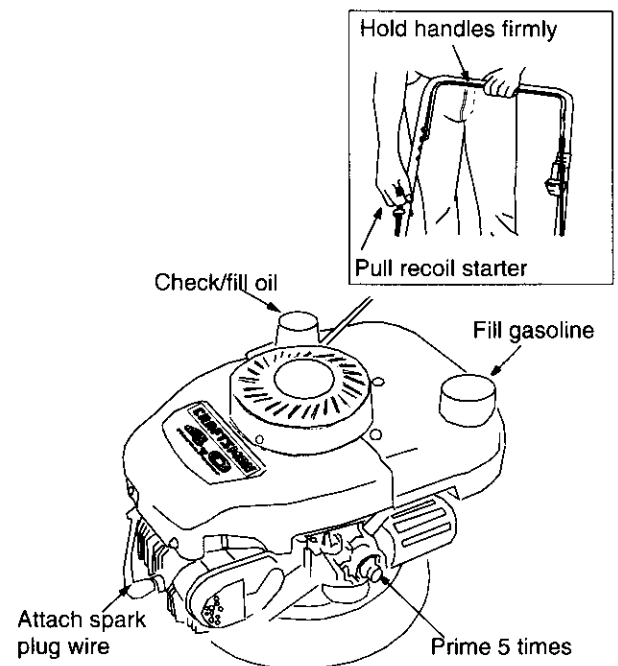

Figure 9

Using Your Lawn Mower

Your mower is designed to operate as a mulching or a rear bagger unit.

- For converting from a mulcher to a rear bagger unit, refer to instructions on page 8 of this manual. **Do not operate mower without the mulching cover or the grass catcher properly installed and tightly secured.**
- Be sure that lawn is clear of stones, sticks, wire, or other objects which could damage lawn mower or engine. Such objects could be accidentally thrown by the mower in any direction and cause serious personal injury to the operator and others.
- *For best results, do not cut wet grass* because it tends to stick to the underside of the mower, preventing proper discharge of grass clippings, and could cause you to slip and fall. New grass, thick grass or wet grass may require a narrower cut.
- The *best mowing pattern* is one that allows the clippings to discharge towards the uncut part of the lawn. This permits recutting of the clippings to further pulverize them. When cutting high weeds, discharge towards cut portion, then recut at right angles to first direction.
- For a *healthy lawn*, always cut off one-third or less of the total length of the grass. Lawn should be cut in the fall as long as there is growth.



WARNING: If the mower strikes a foreign object, **stop the engine.** Disconnect spark plug wire and ground against post. Thoroughly inspect the mower for any damage. Repair the damage before restarting the mower. Extensive vibration during operation is an indication of equipment damage.

Using Grass Catcher

You can use the grass catcher bag to collect clippings while operating the mower.

- Attach the grass catcher to the mower following instructions on page 8 of this manual.
- Operate the mower till the grass catcher bag is full, or the job has been completed whichever is earlier.
- Stop the engine completely by releasing the blade control handle. Make sure that the unit has come to a complete stop and the blade has stopped rotating. Empty the grass catcher bag as follows.
- Lift the discharge door and pull the grass bag away from the mower. See Figure 10.
- Holding the bag firmly, carry the bag away from the mower. Dispose off the clippings appropriately.

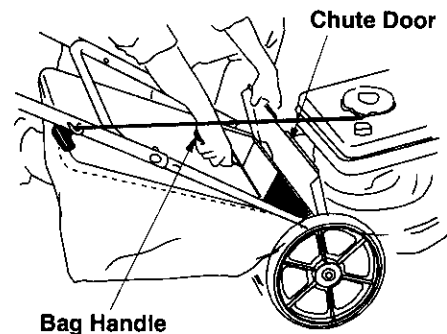

Figure 10

Height Adjustment

Refer to height adjustments section of this manual on page 16 for instruction on how to adjust the cutting height and the handle height.

For best results in mowing, keep the cutting height position high until it is determined which height is best for your lawn.

MAINTENANCE

General Recommendations

- Always observe safety rules when performing any maintenance.
- The warranty on this lawn mower does not cover items that have been subjected to operator abuse or negligence. To receive full value from the warranty, operator must maintain the lawn mower as instructed in this manual.
- Changing of engine governed speed will void engine warranty.
- All adjustments in the Service and Adjustments section of this manual should be checked at least once each season.
- Follow the maintenance schedule given below.
- Periodically check all fasteners and make sure these are tight.



WARNING: Always stop the engine, **disconnect the spark plug wire** and ground it to post before performing any maintenance or adjustments on the mower.

- Drain the gasoline from the lawn mower, or place a piece of plastic under the gas cap.
- Tip the mower so that it rests on the housing. Keep the side with the air cleaner facing up. Hold it firmly.
- Scrape clean the underside of the deck with a suitable tool.
- Put the mower back on its wheels on the ground. If you had put plastic under the gas cap, make sure to remove it now.



WARNING: Never tip the mower more than 90 degrees and **do not leave the mower tipped for any length of time.** Oil can drain into the upper part of the engine causing a starting problem.

NOTE: We do not recommend using a garden hose to clean mower unless the muffler, air filter and carburetor are covered to keep water out. Water in engine can shorten engine life.

Cleaning

The underside of the mower deck should be cleaned after each use to prevent any buildup of grass clippings, leaves, dirt, or other debris. If this debris is allowed to accumulate, it will result in rust and corrosion.

- Disconnect spark plug wire and ground to post on engine.

Engine Maintenance



WARNING: Always **stop engine, disconnect spark plug wire,** and ground it to post before performing any adjustments or repairs on the engine.

Customer Responsibilities

MAINTENANCE SCHEDULE		SERVICE DATES												
		After each use	First two hours	Every 25 hours	Every 50 hours	Every 100 hours	Once a season	Before storage						
PRODUCT	Lubricate wheels						✓							
	Lubricate casters			✓										
	Lubricate blade control						✓							
	Clean deck	✓							✓					
	Blade care			✓					✓					
ENGINE	Change oil		✓	✓										
	Replace air filter cartridge					✓								
	Clean engine							✓						
	Check spark plug				✓			✓						
	Check spark arrester (if any)				✓									

Engine Oil

- Only use high quality detergent oil rated with API service classification SF, SG or SH. Select the oil's viscosity grade according to your expected operating temperature. Refer to page 10 of this manual for viscosity chart.
- Stop engine and wait several minutes before checking oil level. With engine on level ground, the oil must be to FULL mark on dipstick.

To Change Engine Oil

Change oil every 25 hours of mower operation. Drain oil while engine is warm. Follow the instructions given below to change the oil.

- Tip the mower with the spark plug facing up.
- Place a container under the dipstick. Pull the dipstick out of oil fill.
- Drain the oil sump empty, collecting oil in an approved container.
- Fill oil sump with 21 ounces of fresh SAE 30 oil. Refer to page 10 of this manual for oil fill-up instructions.

Air Cleaner

The air cleaner prevents damaging dirt, dust, etc., from entering the carburetor and being forced into the engine and is important to engine life and performance. Replace filter once a year or every 100 operating hours, more often if used in extremely dusty conditions.

To Service Air Cleaner

- Turn air filter cover counterclockwise and remove the cover and filter from the flange. See Figure 11. Discard filter.

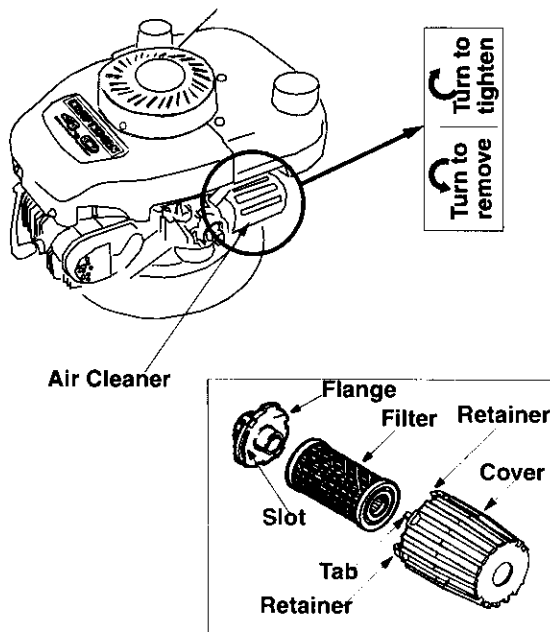

Figure 11

- Clean cover and flange thoroughly.
- Insert the new filter into the cover.
- Place the cover and the filter against flange with tab on the cover inserted into lower left corner of slot in flange. See Figure 11.
- Push cover firmly against flange and turn it clockwise as far as it will go. Make sure that the retainers are locked around the flange. See Figure 11.



WARNING: Never run the engine without air cleaner completely assembled.

To Clean Engine

- Clean engine periodically. Remove dirt and debris with a cloth or brush.
- Frequently remove grass clippings, dirt and debris from cooling fins, air intake screen and levers and linkage. This will help ensure adequate cooling and correct engine speed.

NOTE: Do not clean with a forceful spray of water as water could contaminate the fuel system.

Spark Plug

- Clean spark plug and reset gap to .030" at least once a season or every 50 hours of operation. See Figure 12. Spark plug replacement is recommended at the start of each season. Refer to engine parts list for correct spark plug type.

NOTE: Do not sandblast spark plug. Spark plug should be cleaned by scraping or wire brushing and washing with a commercial solvent.

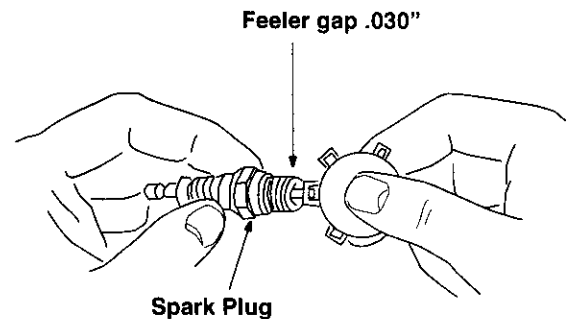

Figure 12

Muffler



WARNING: Do not operate the lawn mower **without a muffler**, or tamper with the exhaust system. Damaged mufflers or spark arresters could create a fire hazard. Temperature of muffler and nearby areas may exceed 150° F(65°C).

Blade Care

Periodically inspect the blade adapter for cracks, especially if you strike a foreign object. Replace when necessary.



WARNING: When inspecting the cutting blade, **protect hands by using heavy gloves or a rag to grasp the cutting blade.**

- Disconnect spark plug wire and ground it to post on engine.
- Turn mower on its side, making sure that the air filter and the carburetor are up, to check the blade. If the blade needs to be serviced, refer to the instructions on “Servicing Blade” on page 15 of this manual.

Lubrication

Wheels

- Lubricate the wheels at least once a season with light oil or engine oil. Also, if the wheels are removed for any reason, lubricate the surface of the axle bolt and the inner surface of the wheel with light oil.

Blade Control Handle

- Lubricate the pivot points on the blade control handle and the brake cable at least once a season with light oil. The blade control handle must operate freely in both directions. For complete lubrication chart, see Figure 13.

Chute Deflector

- Lubricate the torsion spring and the pivot point on each end of the chute deflector using a light oil. This will prevent rusting and ensure that the deflector, which is a safety device, can always work properly.

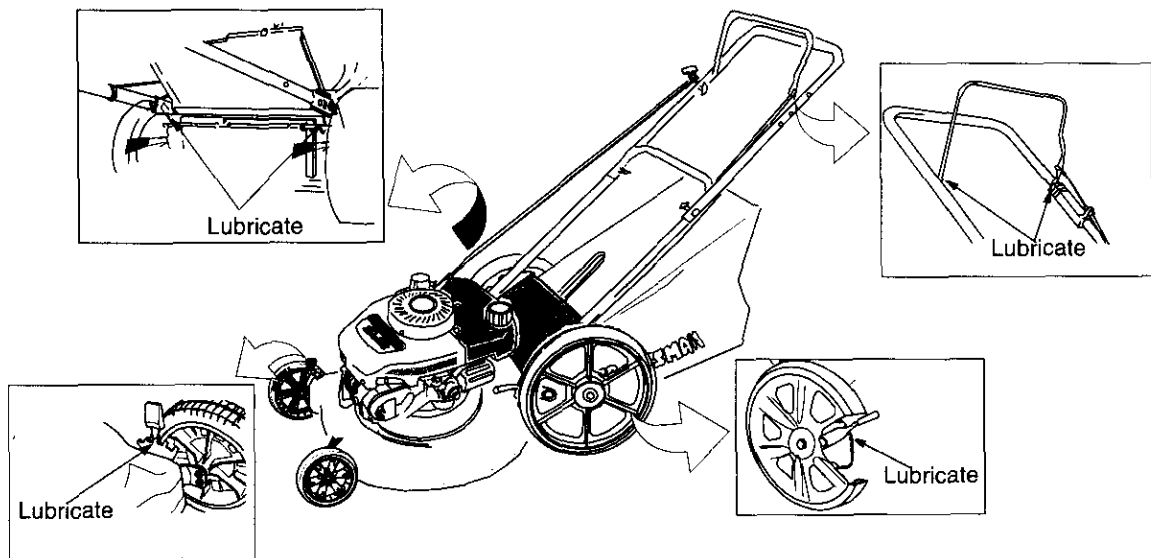

NOTE: For sake of clarity, the pictures in the insets represent view from another perspective rather than from the operating position.

Figure 13: Lubrication Chart

SERVICE & ADJUSTMENTS

Servicing Blade

To Remove Blade

- Remove the bolt, and the blade bell support which holds the blade and adapter to the engine crankshaft. See Figure 14.
- Remove the blade and the adapter from the crankshaft.

To Replace Blade:

- Before reinstalling the blade and the blade adapter to the unit, lubricate the engine crankshaft and the inner surface of the blade adapter with light oil.
- Install the blade adapter on the crankshaft with the "star" away from the engine. See Figure 14.

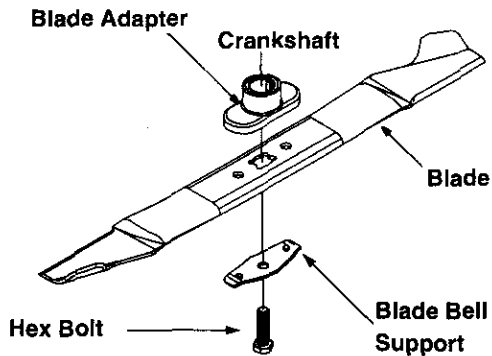

Figure 14

- Place the new blade with the side marked bottom (or with part number) facing away from the adapter.
- Place the bell support next. Make sure to align the tabs in the holes of the blade with the hole in the bell support.
- Insert the hex bolt through the blade assembly. Figure 14 shows the correct order of assembly.
- Use block of wood to hold blade while you tighten the bolt clockwise. Follow the recommended torque for the bolt which is 450-600 in.-lbs.

IMPORTANT: The bolt, used to secure the blade to the engine, is specially heat-treated. **Do not substitute.** To order replacement bolt, refer to the Repair Parts section of this manual.



WARNING: To ensure safe operation of your unit, **all nuts and bolts must be checked** periodically for correct tightness.

To Sharpen Blade:

The blade can be sharpened with a file or on a grinding wheel. Do not attempt to sharpen while on the mower.

- Follow the original angle of grind as a guide. Make sure that each cutting edge receives an equal amount of grinding to prevent an unbalanced blade.

NOTE: An unbalanced blade will cause excessive vibration when rotating at high speeds, may cause damage to the mower and could break, causing personal injury.

- Test the blade by balancing it on a round shaft screwdriver or a blade balancer. See Figure 15.
- If the blade is not balanced, remove metal from the heavy side until it balances evenly.

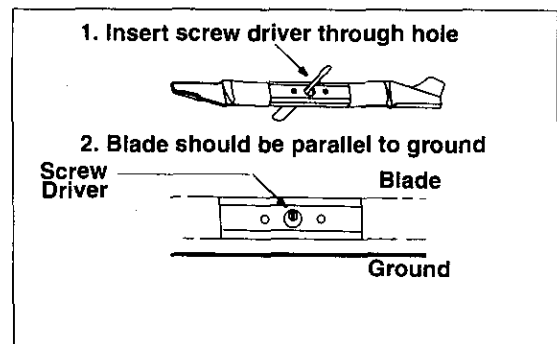

Figure 15

Engine Adjustments



WARNING: Do not make unnecessary adjustments on the engine. Factory settings are satisfactory for most conditions. If any adjustments are made to the engine while the engine is running, **keep clear of all moving parts. Be careful of heated surfaces and muffler. Keep your hands away from these parts.**

Carburetor

The carburetor has been pre-set at the factory and should not require adjustment.

- If the engine on your mower does not operate properly due to suspected carburetor problems, take your lawn mower to your nearest Sears service center.
- Engine performance may be affected in altitudes above 4000 feet. To improve engine performance, install a high altitude adjustment kit, available at the Sears service center.

NOTE: A dirty air cleaner will cause an engine to run rough. Be certain air cleaner is clean and attached to the carburetor.

Engine Speed



WARNING: Overspeeding engine above the factory setting can be **dangerous**. Do not attempt to increase engine speed or it may result in personal injury. Changing of engine governed speed **will void engine warranty**.

- If you believe the engine is running too fast or too slow, take your lawn mower to the nearest Sears service center.

Adjusting Handle Height

Your mower is shipped with the handle in the higher height position. To lower the handle height, proceed as follows.

- Remove the starter rope from the rope guide.
- Remove the upper handle by removing the hand knobs and carriage bolts. Lay the upper handle out of the way, being careful not to bend or kink the cable.
- Remove carriage bolts, wing nuts and hairpin clips from both sides of the lower handle. Press out on the legs of the lower handle. Remove lower handle from the mower.
- Turn the lower handle around so the notch on the bottom of the lower handle is facing forward as shown in Figure 16. Reassemble, placing the bottom hole on the handle over the weld pin in the handle mounting bracket. Reinsert hairpin clip in the hole on weld pin. Repeat on other side.
- Reinstall carriage bolts, earlier removed, on the lower handle and secure with wing nuts.

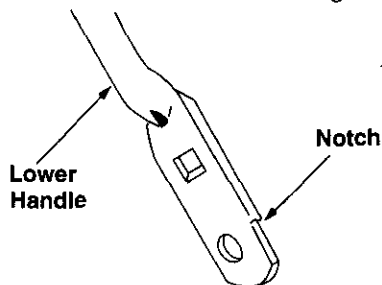

Figure 16

Adjusting Cutting Height

IMPORTANT: All wheels must be placed in the same relative position. *Raise the mower wheels for low cut and lower the wheels for high cut.* For rough or uneven lawns, move the height adjustment lever to a higher position. This will help stop scalping of the grass.

There is an adjusting plate and thumb lever at each wheel position to adjust the cutting height. Each adjusting plate has nine height positions. Height of cut will change if you move the thumb lever from one hole to another.

- Simply depress the lever towards wheel and move the wheel and lever assembly to the desired position. Figure 17 shows the rear wheel height adjustment lever and Figure 18 shows the front wheel height adjustment lever. All wheels must be placed in the same relative position for uniform cutting height.

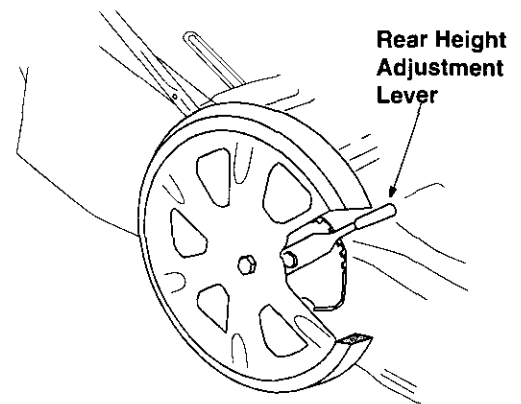

Figure 17

- For rough or uneven lawns, move the height adjustment levers to positions which will give a higher cutting height. Both front and rear levers must be placed in the same relative position.

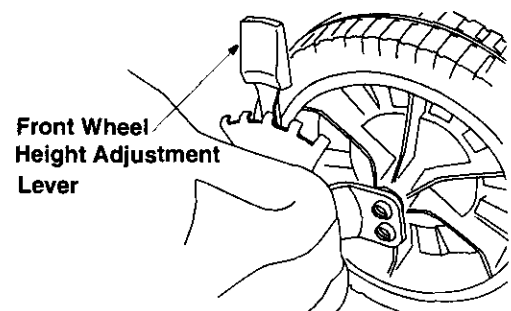

Figure 18

STORAGE

Prepare your lawn mower for storage at the end of the season or **if the unit will not be used for 30 days** or more. Store the mower in a **clean, dry area**.

Mower

- Clean the mower thoroughly.
- Inspect and replace/sharpen blade, if required.
- Lubricate mower following the lubrication chart on page 14 of this manual.

You can fold your mower's handle for convenient storage as shown in Figure 19. Follow the steps below to fold the handle.

- Remove the starter rope from the rope guide.
- Loosen the two hand knobs on the sides of the handle, and let the upper handle fold down to the rear.
- Remove carriage bolt and wing nut from each handle bracket.
- Spread the sides of the lower handle, and push it forward and down.

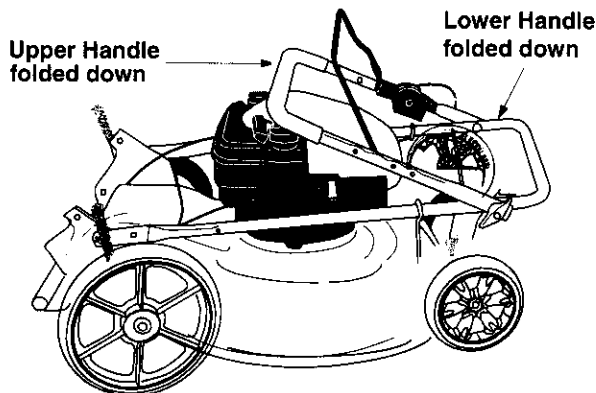

Figure 19

NOTE: When folding the handle, be careful not to bend or kink the cable.

Engine

IMPORTANT: It is important to prevent gum deposits from forming in essential fuel system parts such as carburetor, fuel filter, fuel hose, or tank during storage. Also, experience indicates that alcohol blended fuels (called gasohol or using ethanol or methanol) can attract moisture which leads to separation and formation of acids during storage. Acidic gas can damage the fuel system of an engine while in storage.

Drain fuel system & carburetor



WARNING: Drain fuel into approved container outdoors **away from open flame**. Be sure engine is cool. **Do not smoke**.

- Drain the fuel tank. Start the engine and let it run until the fuel lines and carburetor are empty.
- Loosen the bowl drain screw **a few turns**. The bowl drain screw is located below the carburetor. See Figure 20. Do not remove the screw completely. Drain the carburetor

Note: Do not drain carburetor if using fuel stabilizer.



WARNING: Never use engine or carburetor cleaner products in the fuel tank or **permanent damage** may occur.

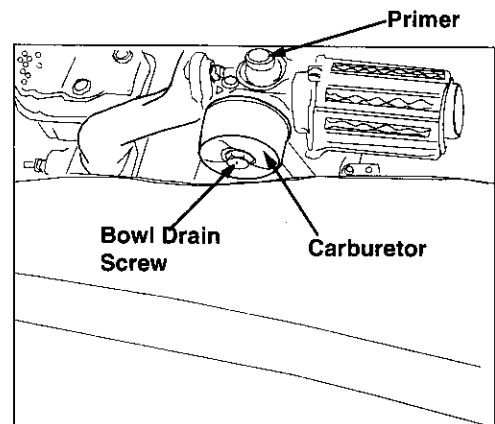

Figure 20

Use fuel stabilizer

NOTE: Fuel stabilizer is an acceptable alternative in minimizing the formation of fuel gum deposits during storage.

- Add stabilizer to gasoline in fuel tank or storage container. Always follow the mix ratio found on stabilizer container.
- Run engine at least 10 minutes after adding stabilizer to allow the stabilizer to reach the carburetor.
- Do not drain the gas tank and carburetor if using fuel stabilizer. Drain all the oil from the crankcase (This should be done after the engine has been operated and is still warm) and refill the crankcase with fresh oil.

Oil cylinder bore

After you have drained the fuel tank, protect the inside of the engine as follows:

- Remove spark plug, pour approximately one ounce (30 ml) of engine oil into spark plug hole, and crank slowly to distribute oil.



WARNING: Avoid spray from spark plug hole when cranking the engine slowly.

- Replace spark plug; do not connect spark plug wire.

Change oil

- Change oil if it has not been changed in the last three months.

Clean engine

- Clean engine and remove all grass clippings, dirt, and chaff from the exterior of the engine.
- Remove any dirt or debris that may have accumulated on the cooling fins, intake screen levers, and linkages.

OTHER

- Do not store gasoline from one season to another. Replace your gasoline can if it starts to rust. Rust and/or dirt in the gasoline will cause problems.
- Store unit in a clean, dry area. Do not store next to corrosive materials, such as fertilizer.

NOTE: *If storing in an unventilated or metal storage shed, be certain to rustproof the equipment by coating with a light oil or silicone.*

TROUBLE-SHOOTING

PROBLEM	POSSIBLE CAUSE	CORRECTIVE ACTION
Engine fails to start	<ol style="list-style-type: none"> 1. Blade control handle disengaged 2. Spark plug wire disconnected 3. Fuel tank empty, or stale fuel 4. Blocked fuel line 5. Faulty spark plug 	<ol style="list-style-type: none"> 1. Engage blade control handle. 2. Connect wire to spark plug. 3. Fill tank with fresh, clean fuel. 4. Clean fuel line. 5. Clean, adjust gap or replace.
Engine runs erratic	<ol style="list-style-type: none"> 1. Spark plug wire loose 2. Blocked fuel line or stale fuel 3. Vent in gas cap plugged 4. Water or dirt in fuel system 5. Dirty air cleaner 	<ol style="list-style-type: none"> 1. Connect and tighten spark plug wire. 2. Clean fuel line, fill tank with clean, fresh gasoline. 3. Clear vent. 4. Drain fuel tank. Refill with fresh fuel. 5. Clean air cleaner. Refer to Maintenance section of this manual.
Engine overheats	<ol style="list-style-type: none"> 1. Engine oil level low 2. Air flow restricted 	<ol style="list-style-type: none"> 1. Fill crankcase with proper oil. 2. Clean lawn mower engine.
Occasional skip (hesitates) at high speed	<ol style="list-style-type: none"> 1. Spark plug gap too close 	<ol style="list-style-type: none"> 1. Adjust gap to .030 inches.
Idles poorly	<ol style="list-style-type: none"> 1. Spark plug fouled, faulty, or gap too wide 2. Dirty air cleaner 	<ol style="list-style-type: none"> 1. Reset gap to .030 inches or replace spark plug. 2. Clean air cleaner following instructions on page 13.
Excessive vibration	<ol style="list-style-type: none"> 1. Cutting blade loose or unbalanced 2. Bent cutting blade 3. Bent engine crankshaft 	<ol style="list-style-type: none"> 1. Tighten blade and adapter, balance blade. 2. Replace blade. 3. Contact your SEARS Service Center.
Mower will not mulch grass	<ol style="list-style-type: none"> 1. Wet grass 2. Excessively high grass 3. Dull blade 	<ol style="list-style-type: none"> 1. Wait until later to cut. 2. Mow once at a high cutting height, then mow again at desired height. Make a narrower cutting swath (1/2) width. Do not cut off more than 1/3 of the total length. 3. Sharpen or replace blade.
Uneven cut	<ol style="list-style-type: none"> 1. Wheels not in same height position 2. Dull blade 	<ol style="list-style-type: none"> 1. Place all four wheels in same relative height position. 2. Sharpen or replace blade.



For repairs beyond the minor adjustments listed above, please contact your nearest Sears Service Center or call 1-800-4-MY-HOME.

PARTS LIST

SEARS CRAFTSMAN 4.0 H.P. LAWN MOWER MODEL 247.388250

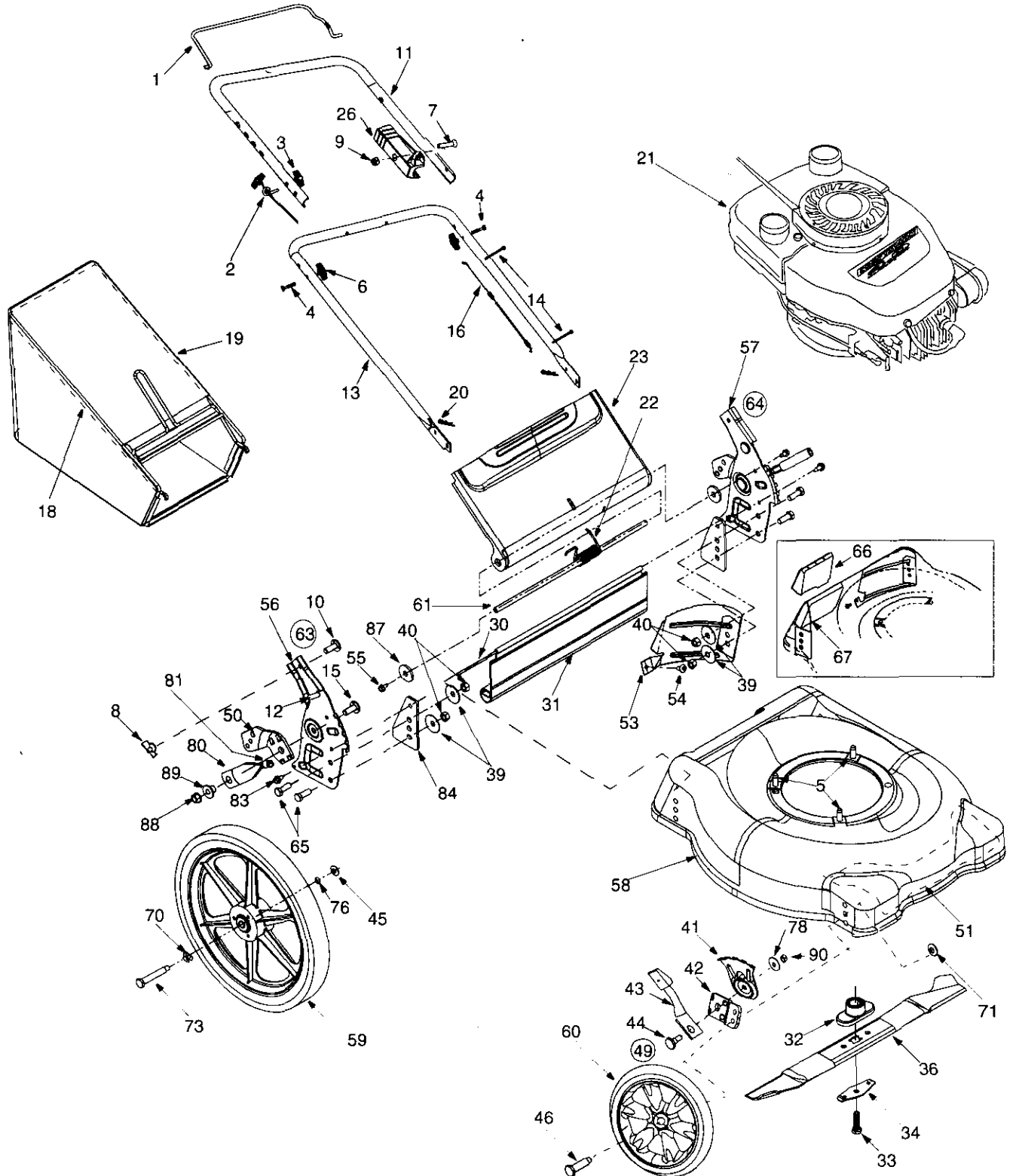

SEARS CRAFTSMAN 4.0 H.P. LAWN MOWER MODEL 247.388250

Key No.	Part No.	Description	Key No.	Part No.	Description
1	747-0824	Control Handle Assembly - Standard	46	738-0102	Front Axle Bolt
2	710-1205	Rope Guide	49	14578	Height Adjuster Ass'y Comp. - R.H.
3	720-0279	Handle Knob		14579	Height Adjuster Ass'y Comp. - L.H. (not shown)
4	710-1174	Curved Hd. Bolt 5/16-18 X 2" Lg.			
5	710-0654A	Scr. TT. 3/8-16 X 1.00" Lg. Hx Indwash.	50	17488A	Pivot Bar - R.H.
6	720-0276	Hand Knob		17489A	Pivot Bar - L.H. (not shown)
7	710-1270	Oval C-sunk Scr. 1/4-20 X 1.310 Lg.	51	782-5025	Front Baffle
8	712-0397	Wing Nut	53	782-5026	Rear Baffle - L.H.
9	712-0324	Hex Lock Nut 1/4-20 Thd.	54	710-1017	Torx Mach.Ab-Tap Scr. 1/4-14 x .625.
10	710-0703	Carriage Bolt 1/4-20 x 0.75"	55	710-0599	Scr. TT. 1/4-20 x .500 HxIndWash.
11	749-0538C-0637	Upper Handle	56	682-3036	Handle Bracket Assembly - R.H.
			57	682-3037	Handle Bracket Assembly - L.H.
13	749-0928-0637	Lower Handle	58	782-0054A-0689	Deck
14	726-0240	Cable Tie	59	734-1864	Rear Wheel Ass'y. 14 x 1.8 Bar Grey (Inc. 741-0484 Brg. not illustrated)
15	710-0435	Weld Screw 3/8-16 x 1.0"			
16	746-0737	Control Cable — 51"	60	734-1841	Fr. Wheel Ass'y. 8 x 1.7 Aero Grey
18	747-0995A	Grass Catcher Frame	61	747-1169	Chute Door Pivot Rod
19	664-0092	Grass Catcher Bag	63	682-3038	Handle Bracket Assembly. - R.H.
20	714-0104	Hairpin Clip	64	682-3039	Handle Bracket Assembly. - L.H.
21	—	Engine, Tecumseh Model 143.994002	65	710-0514	Hex Hd Cap Scr. 3/8-16 x 1.0" Lg.
22	732-0809	Door Spring	66	782-5007B	Rear Mulch Plug
23	782-7599A	Grass Bag Door	67	782-5004	Rear Mulch Baffle
26	746-0883	Control Cable Housing	70	736-0504	Wave Washer
30	732-0957	Wire Rod	71	736-0105	Spring Washer
31	731-1261	Rear Flap	73	738-3056	Rear Axle Bolt
32	748-0376C	Blade Adapter	76	750-0535	Spacer
33	710-1044	Hex Bolt 3/8-24 X 1.5 Lg.	78	736-0356	Bell Washer
34	736-0524A	Blade Bell Support	80	732-0866	Spring Lever, Rear
36	742-0739	19" Blade (Mulching)	81	720-0312	Foam Grip
39	736-0356	Bell Washer .39 I.d. X 1.38 I.d.	83	710-0896	Scr. AB 1/4-14 x .625 HxIndWash.
40	712-0798	Hex Nut 3/8-16 Thd.	84	782-7611	Handle Bracket Support Plate
41	15261A	Height Adj. Plate	87	736-0247	Flat Washer 3/8 x 1.25
42	15262B	Pivot Bar	88	712-0431	Flange Lock Nut
43	14832	Spring Lever, Front Wheel	89	748-0423	Shoulder Spacer 3/8"
44	738-0507B	Shoulder Bolt, .5" Dia. X .357"	90	712-0798	Hex Nut 3/8-16 Thd.
45	736-0105	Bell Wash. .38" I.d. X .88" O.d.			

**CRAFTSMAN ENGINE NO. 143.994002 FOR
CRAFTSMAN 4.0 H.P. LAWN MOWER MODEL 247.388250**

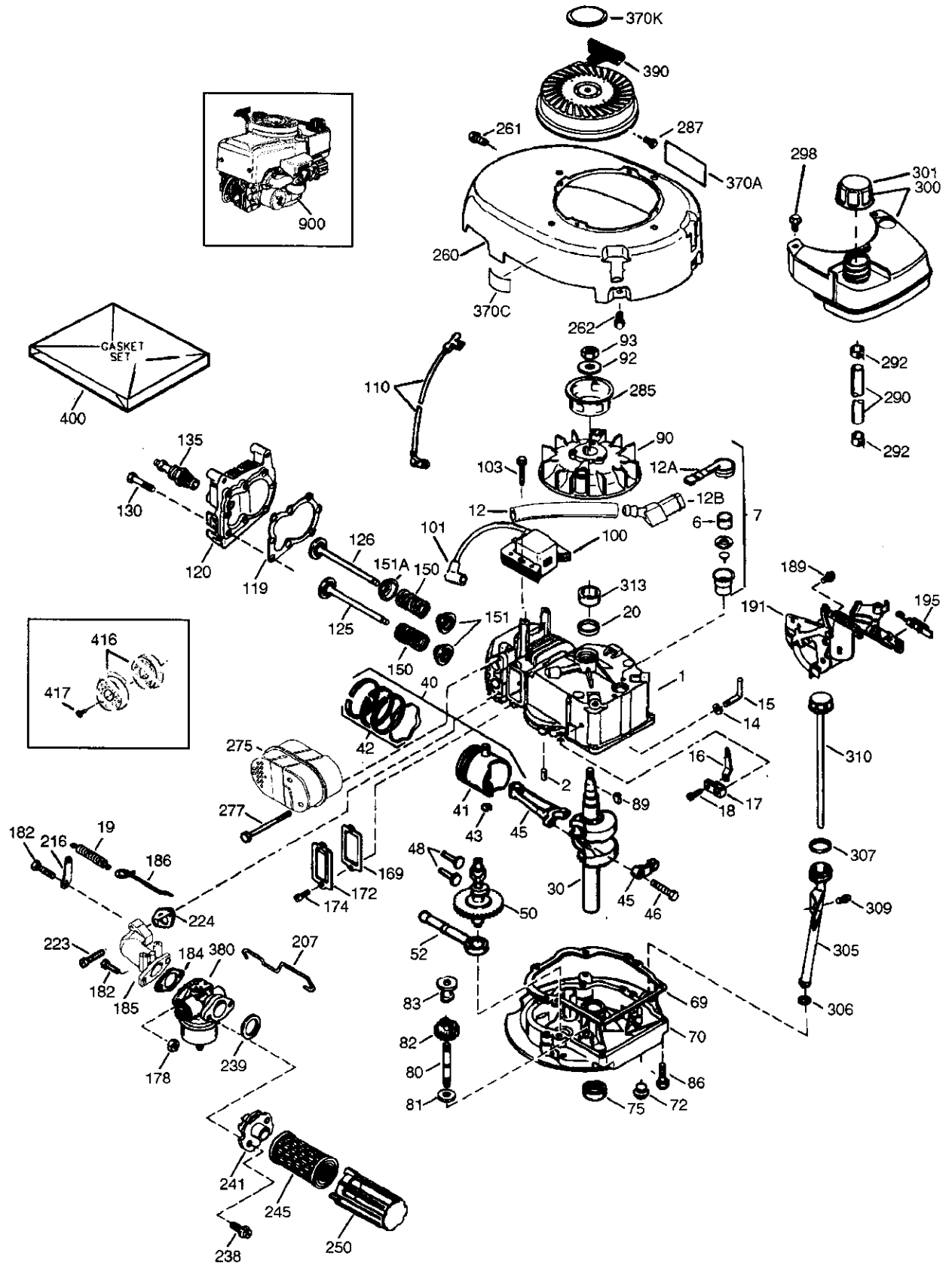

**CRAFTSMAN ENGINE NO. 143.994002 FOR
CRAFTSMAN 4.0 H.P. LAWN MOWER MODEL 247.388250**

Key No.	Part No.	Description	Qty.	Key No.	Part No.	Description	Qty.
1	37280	Cylinder (Incl. 2,20 & 150)		130	6021A	Screw, 5/16-18 x 1-1/2"	8
2	26727	Dowel Pin	2	135	35395	Resistor Spark Plug (RJ19LM)	1
6	33734	Breather Element	1	150	31672	Valve Spring	2
7	36557	Breather Ass'y. (Incl. 6 & 12A)	1	151	31673	Valve Spring Cap	2
12	36775	Breather Tube	1	151A	40017	Intake Valve Seal	1
12A	36558	Breather Cover & Tube (Incl. 12B)	1	169	36783	Valve Cover Gasket	1
12B	36694	Breather Tube Elbow	1	172	36784	Valve Cover	1
14	28277	Washer	1	174	30200	Screw, 10-24 x 9/16"	2
15	30589	Governor Rod (Incl. 14)	1	178	29752	Nut & Lock Washer, 1/4-28	2
16	34839A	Governor Lever	1	182	6201	Screw, 1/4-28 x 7/8"	2
17	31335	Governor Lever Clamp	1	184	26756	Carburetor - Intake Pipe Gasket	1
18	651018	Screw, Torx T-15, 8-32 x 19/64"	1	185	36785	Intake Pipe	1
19	36281	Extension Spring	1	186	32653	Governor Link	1
20	32600	Oil Seal	1	189	650839	Screw, 1/4-20 x 3/8"	2
30	36797	Crankshaft	1	191	36559A	S.E. Brake Bracket (Incl. 195)	1
40	35544A	Piston, Pin & Ring Set (Std.)	1	195	610973	Terminal	1
40	35545A	Piston, Pin & Ring Set (.010" OS)	1	207	34336	Throttle Link	1
40	35546	Piston, Pin & Ring Set (.020" OS)	1	216	33086	R.P.M. Adjusting Lever	1
41	35541	Piston & Pin Ass'y. (Std.) (Incl. 43)	1	223	650451	Screw, 1/4-20 x 1"	2
41	35542	Piston & Pin Ass'y. (.010" OS) (Incl. 43)	1	224	36786	Intake Pipe Gasket	1
41	35543	Piston & Pin Ass'y. (.020" OS) (Incl. 43)	1	238	650932	Screw, 10-32 x 49/64"	2
42	35547A	Ring Set (Std.)	1	239	34338	Air Cleaner Gasket	1
42	35548A	Ring Set (.010" OS)	1	241	35797	Air Cleaner Collar	1
42	35549	Ring Set (.020 OS)	1	245	35066	Air Cleaner Filter	1
43	20381	Piston Pin Retaining Ring	2	250	35065	Air Cleaner Cover	1
45	36777	Connecting Rod Ass'y. (Incl. 46)	1	260	36980	Blower Housing	1
46	32610A	Connecting Rod Bolt	2	261	30200	Screw, 10-24 x 9/16"	2
48	27241	Valve Lifter	2	262	650831	Screw, 1/4-20 x 1/2"	2
50	37032	Camshaft (NCR)	1	275	36790A	Muffler	1
52	29914	Oil Pump Ass'y.	1	277	650988	Screw, 1/4-20 x 2-5/16"	2
69	35261	Mounting Flange Gasket	1	285	35000A	Starter Cup	1
70	34311E	Mounting Flange (Incl. 72 thru 83,306)	1	287	650926	Screw, 8-32 x 21/64"	2
72	36083	Oil Drain Plug	1	290	29774	Fuel Line	1
75	27897	Oil Seal	1	292	26460	Fuel Line Clamp	2
80	30574A	Governor Shaft	1	298	28763	Screw, 10-32 x 35/64"	3
81	30590A	Washer	1	300	36916	Fuel Tank (Incl. 292 & 301)	1
82	30591	Governor Gear Ass'y. (Incl. 81)	1	301	36246	Fuel Cap	1
83	30588A	Governor Spool	1	305	35647	Oil Fill Tube	1
86	650488	Screw, 1/4-20 x 1-1/4"	6	306	36996	"O"-Ring	1
89	611004	Flywheel Key	1	307	35499	"O"-Ring	1
90	611112	Flywheel	1	309	650562	Screw, 10-32 x 1/2"	1
92	650815	Belleville Washer	1	310	35648	Dipstick	1
93	650816	Flywheel Nut	1	313	34080	Spacer	1
100	34443B	Solid State Ignition	1	370A	36261	Lubrication Decal	2
101	610118	Spark Plug Cover	1	370C	37199	Primer Decal	1
103	651007	Screw, Torx T-15, 10-24 x 15/16"	2	370K	36695	Starter Decal	1
110	37047	Ground Wire	1	380	640173	Carburetor (Incl. 184)	1
119	37028	Cylinder Head Gasket	1	390	590737	Rewind Starter*	1
120	36825	Cylinder Head	1	400	37029A	Gasket Set	1
125	37288	Exhaust Valve (Std.) (Incl. 151)	1	416	36085	Spark Arrestor Kit (Optional)	1
126	37289	Intake Valve (Std.) (Incl. 151)	1	417	650821	Screw, 10-32 x 1/2" (Optional)	1
				900	0	Replacement Engine NONE, order from 71-9990	
				900	0	Replacement Short Block 750836	1

* This engine could have been built with 590694 starter

**CRAFTSMAN ENGINE NO. 143.994002 FOR
CRAFTSMAN 4.0 H.P. LAWN MOWER MODEL 247.388250**

Carburetor No. 640173

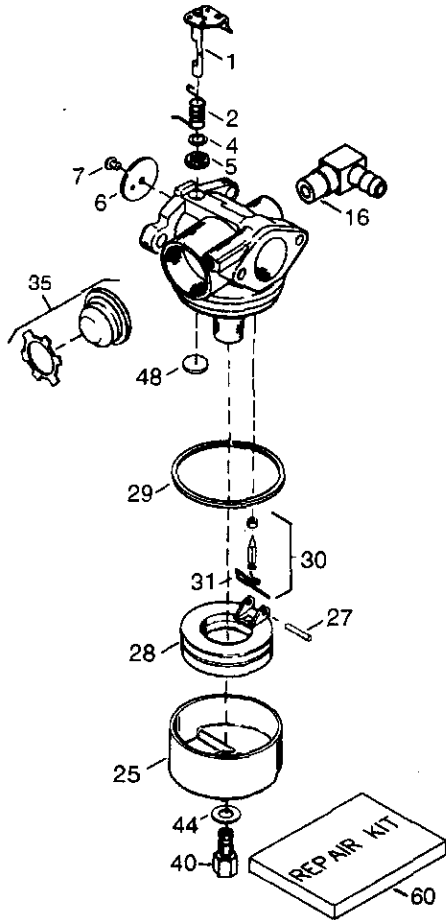

Key No.	Part No.	Description	Qty.
1	631615	Throttle Shaft & Lever Assembly	
2	631767	Throttle Return Spring	1
4	631184	Dust Seal Washer (Throttle)	1
5	631183	Dust Seal (Throttle)	1
6	631616	Throttle Shutter	1
7	650506	Shutter Screw	
16	631807	Fuel Fitting	1
25	631700	Float Bowl	1
27	631024	Float Shaft	1
28	632019	Float	1
29	631028	Float Bowl "O" Ring	1
30	631021	Inlet Needle, Seat & Clip (Incl. 31)	1
31	631022	Spring Clip	1
35	632047A	Primer Bulb/Retaining Ring	1
40	631937A	High Speed Bowl Nut	1
44	631334	Bowl Nut Washer	1
48	631027	Welch Plug, Atmospheric Vent	1
60	632760	Repair Kit	1

**CRAFTSMAN ENGINE NO. 143.994002 FOR
CRAFTSMAN 4.0 H.P. LAWN MOWER MODEL 247.388250**

Recoil Starter 590694

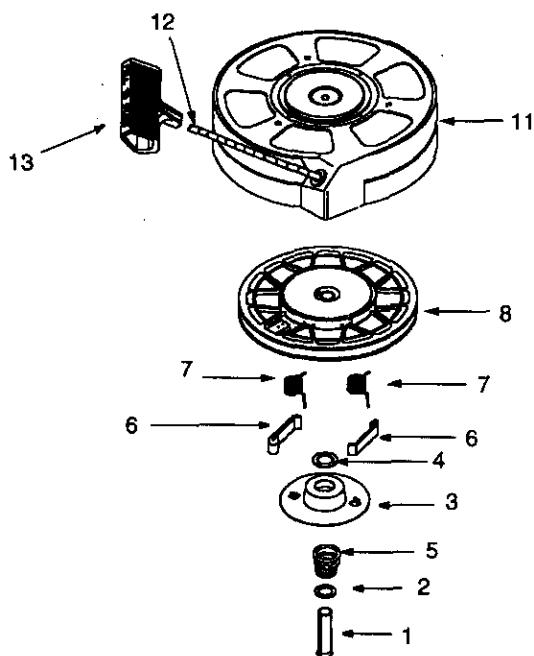

Key No.	Part No.	Description
--	590694	Recoil Starter
1	590599A	Spring Pin
2	590600	Washer
3	590696	Retainer
4	590601	Washer
5	590697	Brake Spring
6	590698	Starter Dog
7	590699	Dog Spring
8	590700	Pulley & Rewind Spring Ass'y.
11	590695	Starter Housing Ass'y. (40 degree grommet)
12	590535	Starter Rope (98" x 9/64" dia.)
13	590701	Starter Handle

Recoil Starter 590737

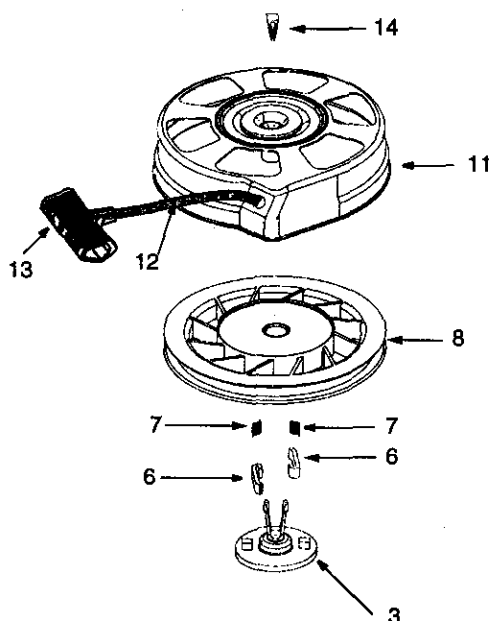

Key No.	Part No.	Description
--	590737	Rewind Starter
3	590740	Retainer
6	590616	Starter Dog
7	590617	Dog Spring
8	590618A	Pulley & Rewind Spring Ass'y.
11	590687A	Starter Housing Ass'y (40 Degree Grommet)
12	590535	Starter Rope (98" X 9/64")
13	590701	Starter Handle
14	590760	Spring Clip

In U.S.A. or Canada

for in-home major brand repair service:

Call 24 hours a day, 7 days a week

1-800-4-MY-HOMESM (1-800-469-4663)

Para pedir servicio de reparación a domicilio — 1-800-676-5811

Au Canada pour tout le service ou les pièces — 1-800-469-4663

For the repair or replacement parts you need:

Call 6 a.m. — 11 p.m. CST, 7 days a week

PartsDirectSM

1-800-366-PART (1-800-366-7278)

Para ordenar piezas con entrega a domicilio — 1-800-659-7084

For the location of a Sears Service Center in your area:

Call 24 hours a day, 7 days a week

1-800-488-1222

To purchase or inquire about a Sears Maintenance Agreement:

Call 7 a.m. — 5 p.m. CST, Monday — Saturday

1-800-827-6655



Free Manuals Download Website

<http://myh66.com>

<http://usermanuals.us>

<http://www.somanuals.com>

<http://www.4manuals.cc>

<http://www.manual-lib.com>

<http://www.404manual.com>

<http://www.luxmanual.com>

<http://aubethermostatmanual.com>

Golf course search by state

<http://golfingnear.com>

Email search by domain

<http://emailbydomain.com>

Auto manuals search

<http://auto.somanuals.com>

TV manuals search

<http://tv.somanuals.com>