

# Operator's Manual

# CRAFTSMAN®

## 26" SNOW THROWER

Model No. 247.889720

**DRAFT**

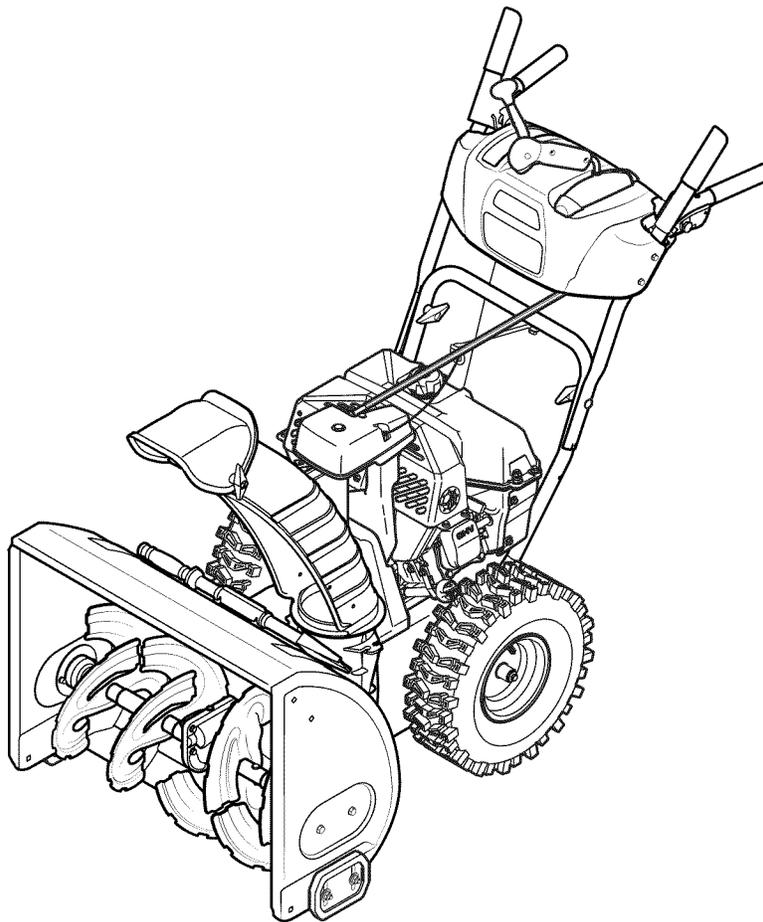

**CAUTION:** Before using this product, read this manual and follow all safety rules and operating instructions.

- SAFETY
- ASSEMBLY
- OPERATION
- MAINTENANCE
- ESPAÑOL

**Sears Brands Management Corporation, Hoffman Estates, IL 60179, U.S.A.**

Visit our website: [www.craftsman.com](http://www.craftsman.com)

Form No. 769-09906  
(June 24, 2014)

# TABLE OF CONTENTS

Warranty Statement.....	Page 2	Off-Season Storage.....	Page 25
Safe Operation Practices .....	Pages 3-6	Troubleshooting .....	Page 26
Assembly .....	Pages 8-13	Repair Protection Agreement.....	Page 30
Operation .....	Pages 14-17	Español.....	Page 31
Service & Maintenance .....	Pages 18-24		

# WARRANTY STATEMENT

## CRAFTSMAN LIMITED WARRANTY

FOR TWO YEARS from the date of purchase, this product is warranted against any defects in material or workmanship.

WITH PROOF OF SALE, a defective product will receive free repair or replacement at option of seller.

### ADDITIONAL LIFETIME LIMITED WARRANTY on UPPER and LOWER CHUTE

FOR AS LONG AS IT IS USED by the original owner after the second year from the date of purchase, the upper and lower chute of this snow thrower are warranted against any defects in material or workmanship as verified by a Sears authorized service provider. With proof of purchase, you will receive a new chute free of charge. You are responsible for the labor cost of installation and any cost incurred to verify the defect.

For warranty coverage details to obtain free repair or replacement, visit the web page: [www.craftsman.com/warranty](http://www.craftsman.com/warranty)

This warranty covers ONLY defects in material and workmanship. Warranty coverage does NOT include:

- Expendable items that can wear out from normal use within the warranty period, including but not limited to augers, auger paddles, drift cutters, skid shoes, shave plate, shear pins, spark plug, air cleaner, belts, and oil filter.
- Standard maintenance servicing, oil changes, or tune-ups.
- Tire replacement or repair caused by punctures from outside objects, such as nails, thorns, stumps, or glass.
- Tire or wheel replacement or repair resulting from normal wear, accident, or improper operation or maintenance.
- Repairs necessary because of operator abuse, including but not limited to damage caused by over-speeding the engine, or from impacting objects that bend the frame, auger shaft, etc.
- Repairs necessary because of operator negligence, including but not limited to, electrical and mechanical damage caused by improper storage, failure to use the proper grade and amount of engine oil, or failure to maintain the equipment according to the instructions contained in the operator's manual.
- Engine (fuel system) cleaning or repairs caused by fuel determined to be contaminated or oxidized (stale). In general, fuel should be used within 30 days of its purchase date.
- Normal deterioration and wear of the exterior finishes, or product label replacement.

This warranty is void if this product is ever used while providing commercial services or if rented to another person.

This warranty gives you specific legal rights, and you may also have other rights which vary from state to state.

Sears Brands Management Corporation, Hoffman Estates, IL 60179

## PRODUCT SPECIFICATIONS

Engine Oil: 5W-30  
Fuel: Unleaded Gasoline  
Engine: Craftsman

## MODEL NUMBER

Model Number \_\_\_\_\_  
Serial Number \_\_\_\_\_  
Date of Purchase \_\_\_\_\_

Record the model number, serial number,  
and date of purchase above.

# SAFETY INSTRUCTIONS

## WARNING

This symbol points out important safety instructions which, if not followed, could endanger the personal safety and/or property of yourself and others. Read and follow all instructions in this manual before attempting to operate this machine. Failure to comply with these instructions may result in personal injury. When you see this symbol, **HEED ITS WARNING!**

## WARNING

### CALIFORNIA PROPOSITION 65

Engine Exhaust, some of its constituents, and certain vehicle components contain or emit chemicals known to State of California to cause cancer and birth defects or other reproductive harm.

## DANGER

This machine was built to be operated according to the safe operation practices in this manual. As with any type of power equipment, carelessness or error on the part of the operator can result in serious injury. This machine is capable of amputating fingers, hands, toes and feet and throwing debris. Failure to observe the following safety instructions could result in serious injury or death.

## WARNING

**Your Responsibility**—Restrict the use of this power machine to persons who read, understand and follow the warnings and instructions in this manual and on the machine.

**SAVE THESE INSTRUCTIONS!**

## TRAINING

- Read, understand, and follow all instructions on the machine and in the manual(s) before attempting to assemble and operate. Failure to do so can result in serious injury to the operator and/or bystanders. Keep this manual in a safe place for future and regular reference and for ordering replacement parts.
- Be familiar with all controls and their proper operation. Know how to stop the machine and disengage them quickly.
- Never allow children under 14 years of age to operate this machine. Children 14 and over should read and understand the instructions and safe operation practices in this manual and on the machine and be trained and supervised by an adult.
- Never allow adults to operate this machine without proper instruction.
- Thrown objects can cause serious personal injury. Plan your snow-throwing pattern to avoid discharge of material toward roads, bystanders and the like.
- Keep bystanders, pets and children at least 75 feet from the machine while it is in operation. Stop machine if anyone enters the area.
- Exercise caution to avoid slipping or falling, especially when operating in reverse.

## PREPARATION

- Thoroughly inspect the area where the equipment is to be used. Remove all doormats, newspapers, sleds, boards, wires and other foreign objects, which could be tripped over or thrown by the auger/impeller.
- Always wear safety glasses or eye shields during operation and while performing an adjustment or repair to protect your eyes. Thrown objects which ricochet can cause serious injury to the eyes.
- Do not operate without wearing adequate winter outer garments. Do not wear jewelry, long scarves or other loose clothing, which could become entangled in moving parts. Wear footwear which will improve footing on slippery surfaces.
- Use a grounded three-wire extension cord and receptacle for all machines with electric start engines.

- Disengage all control levers before starting the engine.
- Adjust collector housing height to clear gravel or crushed rock surfaces.
- Never attempt to make any adjustments while engine is running, except where specifically recommended in the operator's manual.
- Let engine and machine adjust to outdoor temperature before starting to clear snow.

### Safe Handling of Gasoline:

To avoid personal injury or property damage use extreme care in handling gasoline. Gasoline is extremely flammable and the vapors are explosive. Serious personal injury can occur when gasoline is spilled on yourself or your clothes which can ignite. Wash your skin and change clothes immediately.

- Use only an approved gasoline container.
- Never fill containers inside a vehicle or on a truck or trailer bed with a plastic liner. Always place containers on the ground away from your vehicle before filling.
- When practical, remove gas-powered equipment from the truck or trailer and refuel it on the ground. If this is not possible, then refuel such equipment on a trailer with a portable container, rather than from a gasoline dispenser nozzle.
- Keep the nozzle in contact with the rim of the fuel tank or container opening at all times until fueling is complete. Do not use a nozzle lock-open device.
- Extinguish all cigarettes, cigars, pipes and other sources of ignition.
- Never fuel machine indoors.
- Never remove gas cap or add fuel while the engine is hot or running. Allow engine to cool at least two minutes before refueling.
- Never over fill fuel tank. Fill tank to no more than ½ inch below bottom of filler neck to allow space for fuel expansion.
- Replace gasoline cap and tighten securely.
- If gasoline is spilled, wipe it off the engine and equipment. Move unit to another area. Wait 5 minutes before starting the engine.

# SAFETY INSTRUCTIONS

- To reduce fire hazards, keep machine free of grass, leaves, or other debris build-up. Clean up oil or fuel spillage and remove any fuel soaked debris.
- Never store the machine or fuel container inside where there is an open flame, spark or pilot light as on a water heater, space heater, furnace, clothes dryer or other gas appliances.

## OPERATION

- Do not put hands or feet near rotating parts, in the auger/impeller housing or chute assembly. Contact with the rotating parts can amputate hands and feet.
- The auger/impeller control lever is a safety device. Never bypass its operation. Doing so makes the machine unsafe and may cause personal injury.
- The control levers must operate easily in both directions and automatically return to the disengaged position when released.
- Never operate with a missing or damaged chute assembly. Keep all safety devices in place and working.
- Never run an engine indoors or in a poorly ventilated area. Engine exhaust contains carbon monoxide, an odorless and deadly gas.
- Do not operate machine while under the influence of alcohol or drugs.
- Muffler and engine become hot and can cause a burn. Do not touch. Keep children away.
- Exercise extreme caution when operating on or crossing gravel surfaces. Stay alert for hidden hazards or traffic.
- Exercise caution when changing direction and while operating on slopes. Do not operate on steep slopes.
- Plan your snow-throwing pattern to avoid discharge towards windows, walls, cars etc. Thus, avoiding possible property damage or personal injury caused by a ricochet.
- Never direct discharge at children, bystanders and pets or allow anyone in front of the machine.
- Do not overload machine capacity by attempting to clear snow at too fast of a rate.
- Never operate this machine without good visibility or light. Always be sure of your footing and keep a firm hold on the handles. Walk, never run.
- Disengage power to the auger/impeller when transporting or not in use.
- Never operate machine at high transport speeds on slippery surfaces. Look down and behind and use care when backing up.
- If the machine should start to vibrate abnormally, stop the engine, disconnect the spark plug wire and ground it against the engine. Inspect thoroughly for damage. Repair any damage before starting and operating.
- Disengage all control levers and stop engine before you leave the operating position (behind the handles). Wait until the auger/impeller comes to a complete stop before unlogging the chute assembly, making any adjustments, or inspections.
- Never put your hand in the discharge or collector openings. Do not unlog chute assembly while engine is running. Shut off engine and remain behind handles until all moving parts have stopped before unlogging.

- Use only attachments and accessories approved by the manufacturer (e.g. wheel weights, tire chains, cabs etc.).
- When starting engine, pull cord slowly until resistance is felt, then pull rapidly. Rapid retraction of starter cord (kickback) will pull hand and arm toward engine faster than you can let go. Broken bones, fractures, bruises or sprains could result.
- If situations occur which are not covered in this manual, use care and good judgment.

## CLEARING A CLOGGED DISCHARGE CHUTE

Hand contact with the rotating impeller inside the discharge chute is the most common cause of injury associated with snow throwers. Never use your hand to clean out the discharge chute.

To clear the chute:

- a. SHUT THE ENGINE OFF!
- b. Wait 10 seconds to be sure the impeller blades have stopped rotating.
- c. Always use a clean-out tool, not your hands.

## MAINTENANCE & STORAGE

- Never tamper with safety devices. Check their proper operation regularly. Refer to the maintenance and adjustment sections of this manual.
- Before cleaning, repairing, or inspecting machine disengage all control levers and stop the engine. Wait until the auger/impeller come to a complete stop. Disconnect the spark plug wire and ground against the engine to prevent unintended starting.
- Check bolts and screws for proper tightness at frequent intervals to keep the machine in safe working condition. Also, visually inspect machine for any damage.
- Do not change the engine governor setting or over-speed the engine. The governor controls the maximum safe operating speed of the engine.
- Snow thrower shave plates and skid shoes are subject to wear and damage. For your safety protection, frequently check all components and replace with original equipment manufacturer's (OEM) parts only as listed in the Parts pages of this operator's manual. Use of parts which do not meet the original equipment specifications may lead to improper performance and compromise safety!
- Check control levers periodically to verify they engage and disengage properly and adjust, if necessary. Refer to the adjustment section in this operator's manual for instructions.
- Maintain or replace safety and instruction labels, as necessary.
- Observe proper disposal laws and regulations for gas, oil, etc. to protect the environment.
- Prior to storing, run machine a few minutes to clear snow from machine and prevent freeze up of auger/impeller.
- Never store the machine or fuel container inside where there is an open flame, spark or pilot light such as a water heater, furnace, clothes dryer etc.
- Always refer to the operator's manual for proper instructions on off-season storage.

# SAFETY INSTRUCTIONS

- Check fuel line, tank, cap, and fittings frequently for cracks or leaks. Replace if necessary.
- Do not crank engine with spark plug removed.
- According to the Consumer Products Safety Commission (CPSC) and the U.S. Environmental Protection Agency (EPA), this product has an *Average Useful Life* of seven (7) years, or 60 hours of operation. At the end of the *Average Useful Life* have the machine inspected annually by an authorized service dealer to ensure that all mechanical and safety systems are working properly and not worn excessively. Failure to do so can result in accidents, injuries or death.

## DO NOT MODIFY ENGINE

To avoid serious injury or death, do not modify engine in any way. Tampering with the governor setting can lead to a runaway engine and cause it to operate at unsafe speeds. Never tamper with factory setting of engine governor.

## NOTICE REGARDING EMISSIONS

Engines which are certified to comply with California and federal EPA emission regulations for SORE (Small Off Road Equipment) are certified to operate on regular unleaded gasoline, and may include the following emission control systems: Engine Modification (EM), Oxidizing Catalyst (OC), Secondary Air Injection (SAI) and Three Way Catalyst (TWC) if so equipped.

## SPARK ARRESTOR

### WARNING

This machine is equipped with an internal combustion engine and should not be used on or near any unimproved forest-covered, brushcovered or grass-covered land unless the engine's exhaust system is equipped with a spark arrestor meeting applicable local or state laws (if any).

If a spark arrestor is used, it should be maintained in effective working order by the operator. In the State of California the above is required by law (Section 4442 of the California Public Resources Code). Other states may have similar laws. Federal laws apply on federal lands.

A spark arrestor for the muffler is available through your nearest Sears Parts and Repair Service Center.

# SAFETY INSTRUCTIONS

## SAFETY SYMBOLS

This page depicts and describes safety symbols that may appear on this product. Read, understand, and follow all instructions on the machine before attempting to assemble and operate.

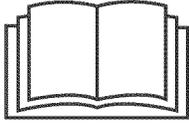
Symbol	Description
	<b>READ THE OPERATOR'S MANUAL(S)</b> Read, understand, and follow all instructions in the manual(s) before attempting to assemble and operate
	<b>WARNING— ROTATING BLADES</b> Keep hands out of inlet and discharge openings while machine is running. There are rotating blades inside
	<b>WARNING— ROTATING BLADES</b> Keep hands out of inlet and discharge openings while machine is running. There are rotating blades inside
	<b>WARNING— ROTATING AUGER</b> Do not put hands or feet near rotating parts, in the auger/impeller housing or chute assembly. Contact with the rotating parts can amputate hands and feet.
	<b>WARNING—THROWN OBJECTS</b> This machine may pick up and throw and objects which can cause serious personal injury.
	<b>WARNING— GASOLINE IS FLAMMABLE</b> Allow the engine to cool at least two minutes before refueling.
	<b>WARNING— CARBON MONOXIDE</b> Never run an engine indoors or in a poorly ventilated area. Engine exhaust contains carbon monoxide, an odorless and deadly gas.
	<b>WARNING— ELECTRICAL SHOCK</b> Do not use the engine's electric starter in the rain
	<b>WARNING— HOT SURFACE</b> Engine parts, especially the muffler, become extremely hot during operation. Allow engine and muffler to cool before touching.



**WARNING:** Your Responsibility—Restrict the use of this power machine to persons who read, understand and follow the warnings and instructions in this manual and on the machine.

**SAVE THESE INSTRUCTIONS!**

This page left intentionally blank.

# ASSEMBLY

**NOTE:** References to right or left side of the snow thrower are determined from behind the unit in the operating position (standing directly behind the snow thrower, facing the handle panel).

## Removing From Carton

1. Cut the corners of the carton and lay the sides flat on the ground. Remove and discard all packing inserts.
2. Move the snow thrower out of the carton.
3. Make certain the carton has been completely emptied before discarding it.

## Assembly

1. Observe the lower rear area of the snow thrower to be sure both cables are aligned with roller guides before pivoting the handle upward.
  - a. Place the shift lever in the F6 position. See Figure 1 inset.
  - b. Pull up and back on upper handle as shown in Figure 1. As you are raising the handle upward, make sure that both ends of the center cable are positioned properly in the brackets. Align upper handle with the lower handle.
  - c. Tighten hand knobs securing upper handle to lower handle. Remove and discard any rubber bands, if present. They are for packaging purposes only.
2. Remove cotter pin, wing nut, and hex screw from chute control head and clevis pin and bow-tie cotter pin from chute support bracket. See Figure 2.
3. Insert chute control rod into input of chute control head. Push rod as far into the chute control head as possible, keeping the holes in the rod pointing upward. See Figure 3.

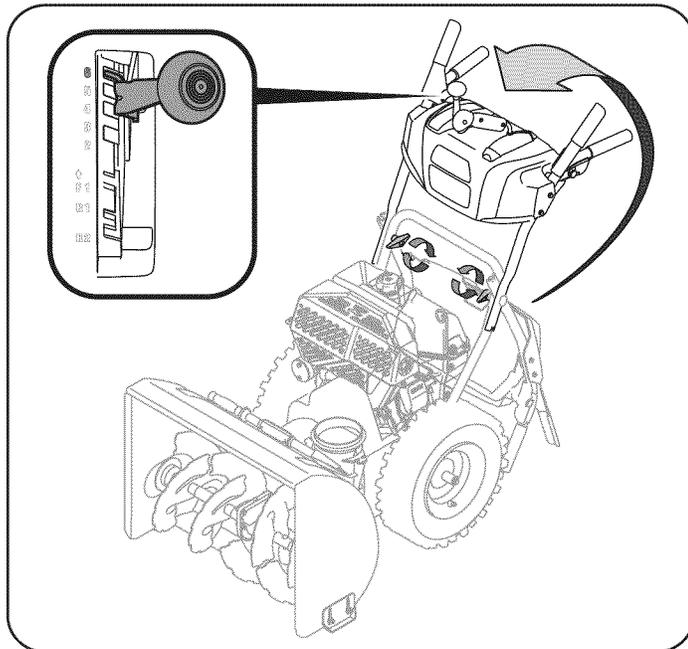

Figure 1

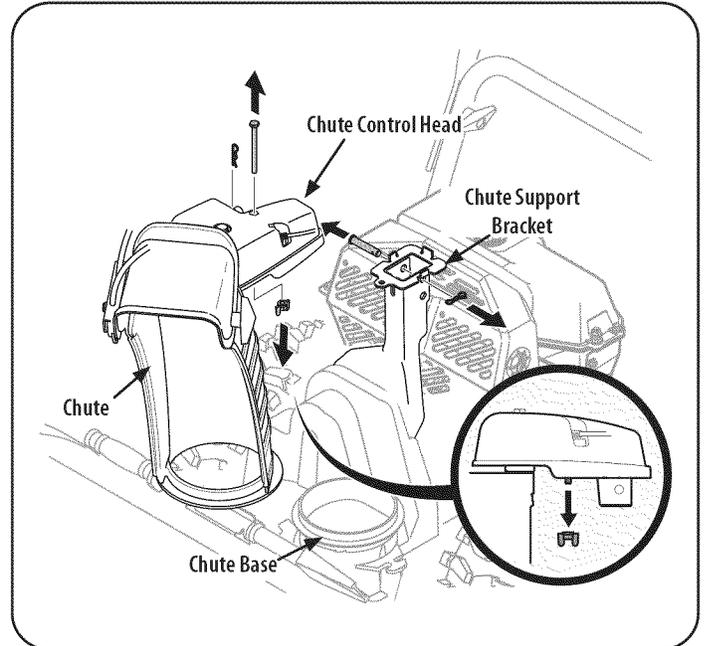

Figure 2

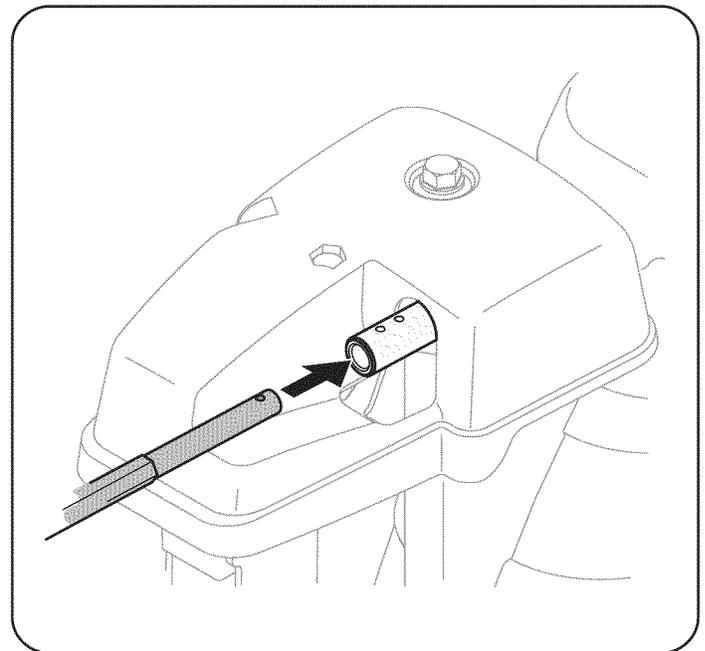

Figure 3

## ASSEMBLY

- Place chute onto chute base and ensure chute control rod is positioned under handle panel. Install hex bolt previously removed but do not secure with wing nut at this time. See Figure 4.
- Squeeze the trigger on the handle panel joystick and rotate the chute by hand to face forward. The holes in the chute control input will be facing up. See Figure 5.

**NOTE:** The chute will not rotate without squeezing the trigger on the joystick.

- Rotate the joystick to the one o'clock position so the silver indicator arrow on the input shaft below the control panel points upward. See Figure 6.

**NOTE:** The joystick will be angled slightly to the right. See Figure 5 & Figure 6.

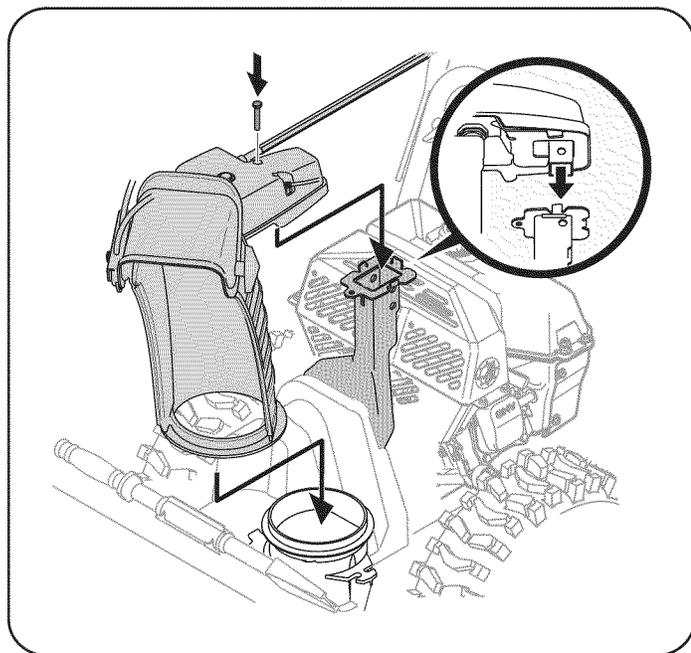

Figure 4

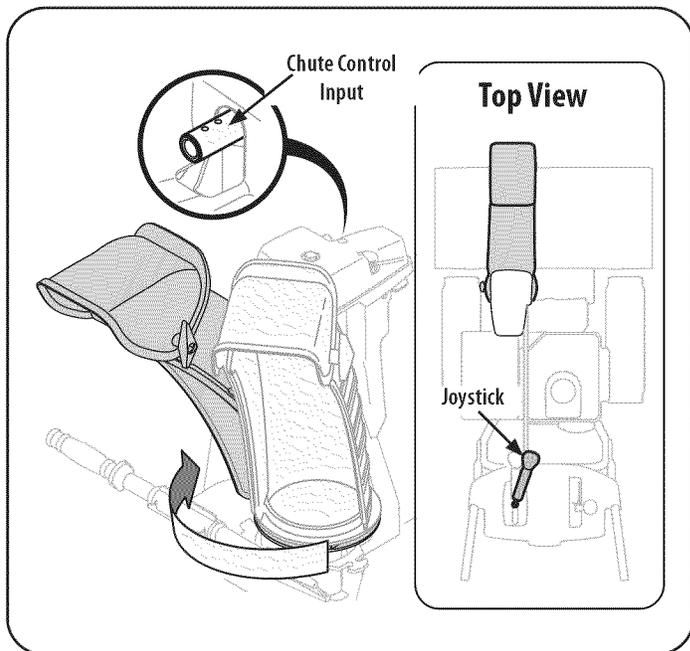

Figure 5

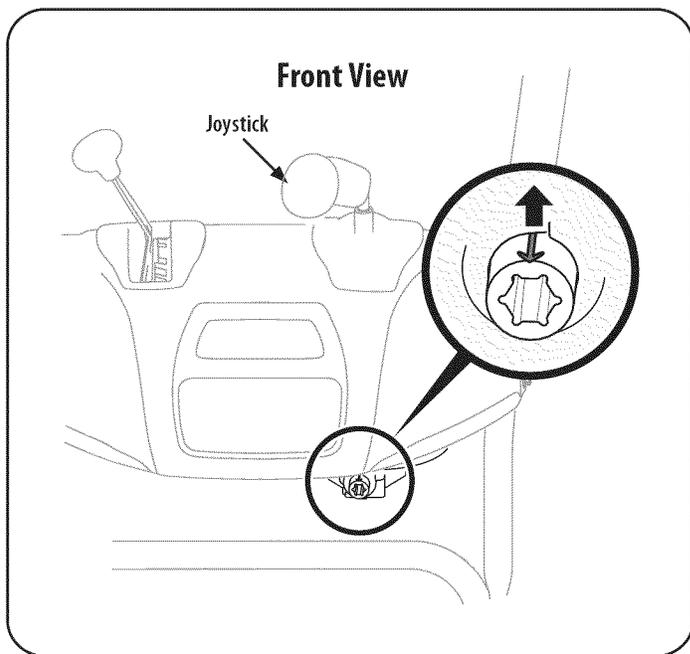

Figure 6

## ASSEMBLY

7. Make sure all cables are routed to the left of the chute control rod. Line up the hole in the rod with the arrow on the input shaft and insert the rod into the input shaft below joystick on handle panel. See Figure 7.

**NOTE:** The chute control rod will fit snugly into the input shaft. Support the rear of the dash panel with one hand while inserting the rod with your other hand to ensure the rod is inserted all the way into the input shaft.

8. Now push the chute control rod back towards the handle panel until the hole in the rod lines up with the hole in the chute control input closest to the chute control head. Insert the cotter pin. See Figure 8.

**NOTE:** The second hole is used to achieve further engagement of the chute control rod into the input shaft if required and can be used later for adjustment if the chute does not fully rotate. Refer to the Service & Maintenance section for Chute Control Rod adjustments.

9. Finish securing chute control head to chute support bracket with wing nut, and clevis pin and bow-tie cotter pin removed earlier. Do not overtighten. See Figure 9.

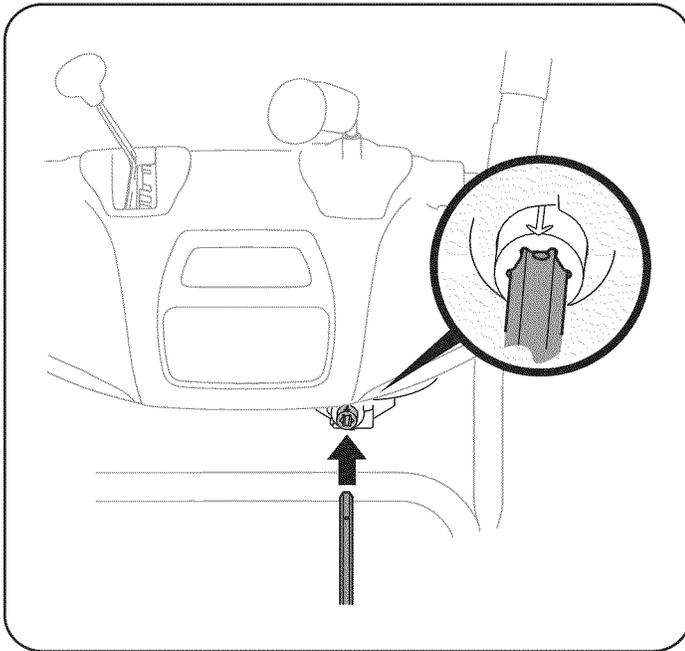

Figure 7

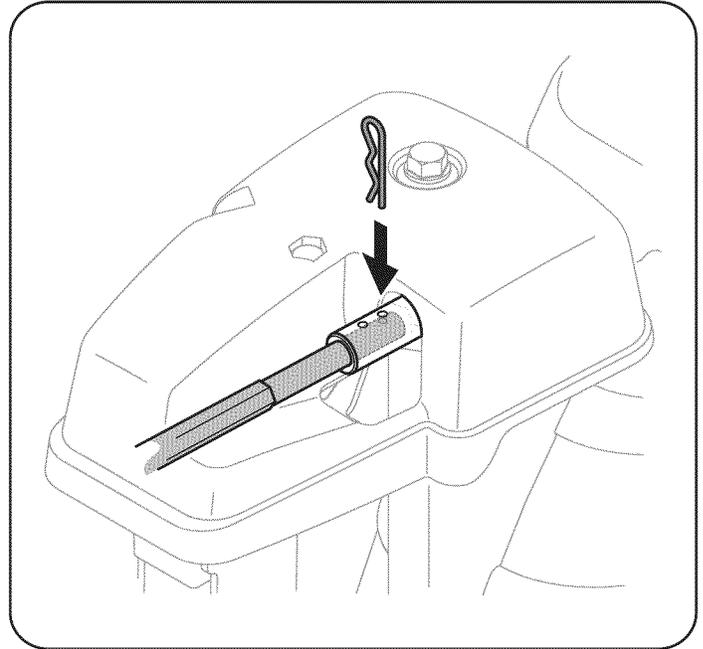

Figure 8

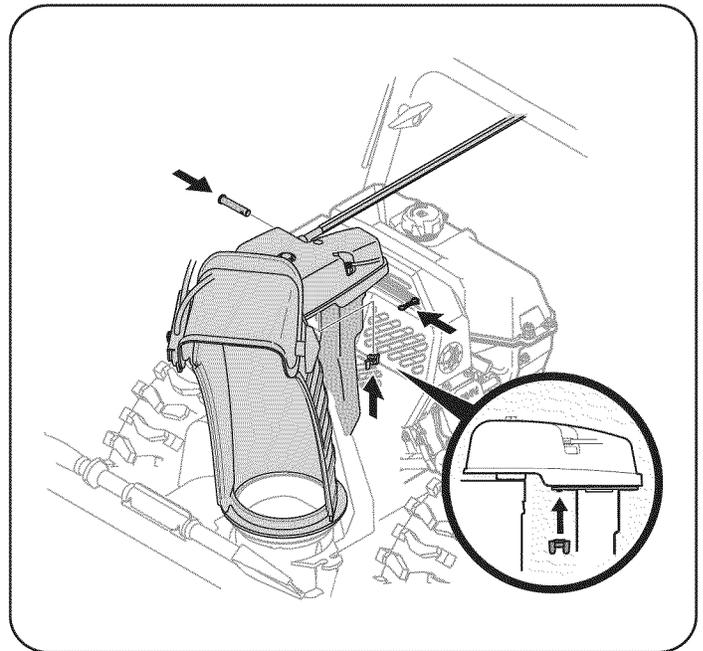

Figure 9

## ASSEMBLY

10. Check that all cables are properly routed through the cable guide on the engine. See Figure 10.

**NOTE:** If the chute control is not assembled correctly it will not move freely nor will it move fully to the right and left.

### Set-Up

#### Shear Pins

Holes are located in the plastic dash panel for convenient shear pin storage. See Figure 11. Refer to the Operation section for more information regarding shear pin replacement.

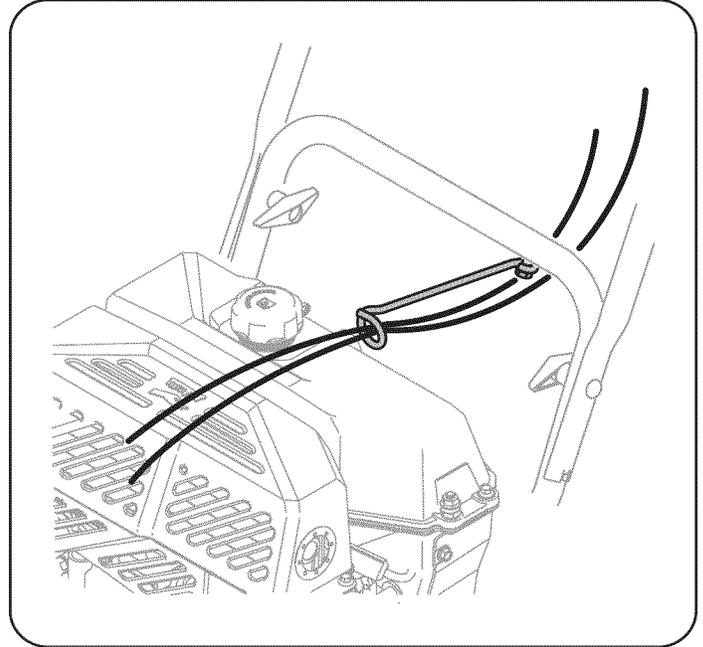

Figure 10

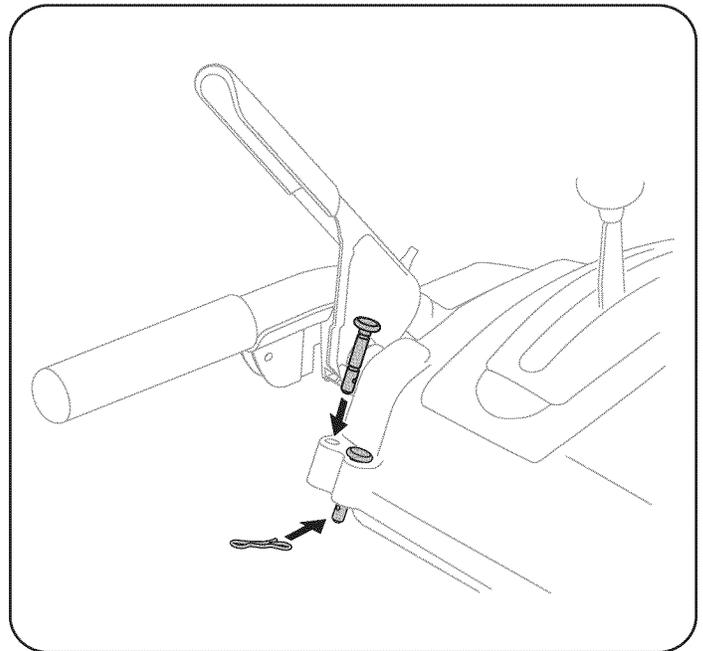

Figure 11

# ASSEMBLY

## Chute Clean-Out Tool

A chute clean-out tool is fastened to the top of the auger housing with a mounting clip. See Figure 12. The tool is designed to clear a chute assembly of ice and snow. This item is fastened with a cable tie at the factory. Cut the cable tie before operating the snow thrower.

### ⚠ WARNING

Never use your hands to clear a clogged chute assembly. Shut off engine and remain behind handles until all moving parts have stopped before using the clean-out tool to clear the chute assembly.

## Tire Pressure

### ⚠ WARNING

Under any circumstance do not exceed manufacturer's recommended psi. Equal tire pressure should be maintained at all times. Excessive pressure when seating beads may cause tire/rim assembly to burst with force sufficient to cause serious injury. Refer to sidewall of tire for recommended pressure.

The tires are over-inflated for shipping purposes. Check the tire pressure before operating the snow thrower. Refer to the tire side wall for tire manufacturer's recommended psi and deflate (or inflate) the tires as necessary.

**NOTE:** Equal tire pressure is to be maintained at all times for performance purposes.

## Adjustments

### Skid Shoes

The snow thrower skid shoes are adjusted upward at the factory for shipping purposes. Adjust them downward, if desired, prior to operating the snow thrower.

### ⚠ CAUTION

It is not recommended that you operate this snow thrower on gravel as it can easily pick up and throw loose gravel, causing personal injury or damage to the snow thrower and surrounding property.

- For close snow removal on a smooth surface, raise skid shoes higher on the auger housing. Refer to Figure 13.
- Use a middle or lower position when the area to be cleared is uneven, such as a gravel driveway.

**NOTE:** If you choose to operate the snow thrower on a gravel surface, keep the skid shoes in position for maximum clearance between the ground and the shave plate.

To adjust the skid shoes:

1. Loosen the four hex nuts (two on each side) and carriage bolts. Move skid shoes to desired position. See Figure 13.
2. Make certain the entire bottom surface of skid shoe is against the ground to avoid uneven wear on the skid shoes.
3. Retighten nuts and bolts securely.

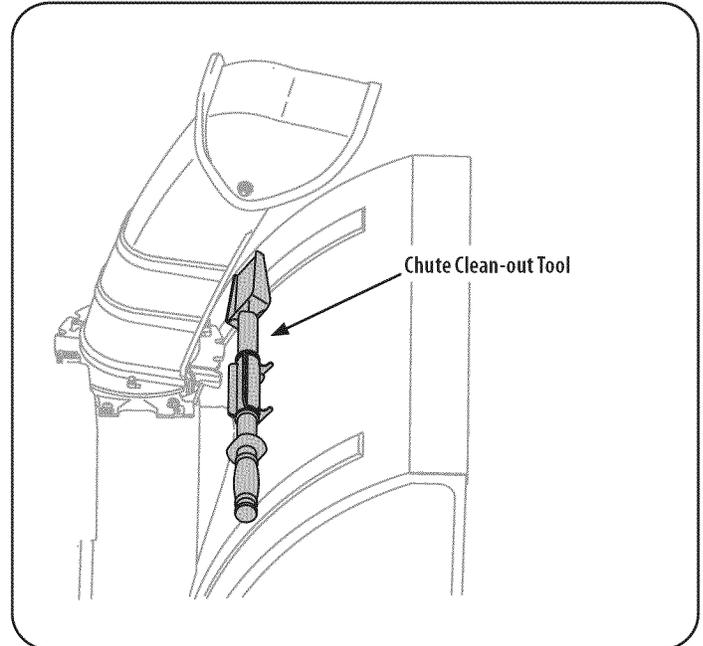

Figure 12

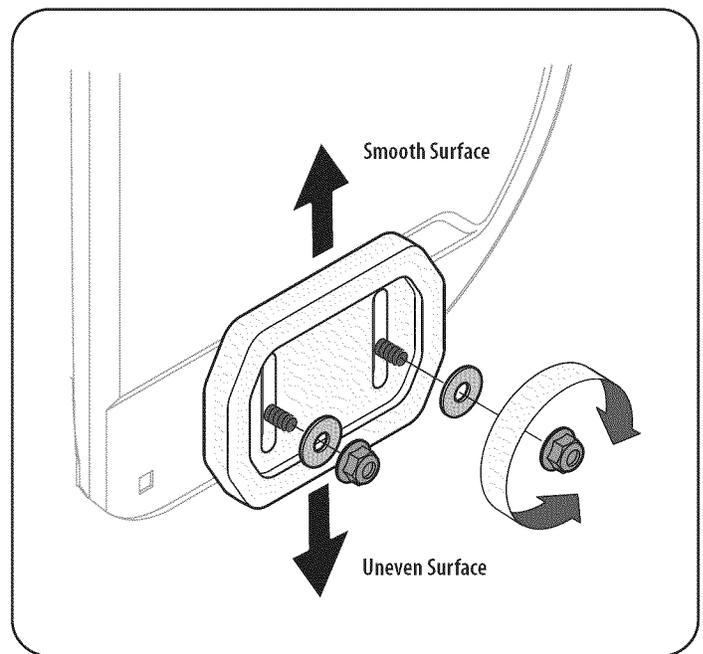

Figure 13

# ASSEMBLY

## Chute

The distance snow is thrown can be adjusted by changing the angle of the upper chute. To do so:

1. Stop the engine by removing the ignition key and loosen the plastic wing knob found on the left side of the chute assembly.
2. Pivot the chute upward or downward before retightening the wing knob. See Figure 14.

## Auger Control

### WARNING

Prior to operating your snow thrower, carefully read and follow all instructions below. Perform all adjustments to verify your snow thrower is operating safely and properly.

Check the adjustment of the auger control as follows:

1. The auger control is located on the left handle. See Figure 15 inset. When the auger control is released and in the disengaged "up" position, the cable should have very little slack. It should NOT be tight.
2. In a well-ventilated area, start the snow thrower engine. Refer to Starting the Engine in the Operation section.
3. While standing in the operator's position (behind the snow thrower), engage the auger.
4. Allow the auger to remain engaged for approximately ten (10) seconds before releasing the auger control. Repeat this several times.
5. With the auger control in the disengaged "up" position, walk to the front of the machine.
6. To readjust the control cable, loosen the upper hex bolt on the auger cable bracket. See Figure 15.
7. Position the bracket upward to provide more slack (or downward to increase cable tension).
8. Retighten the upper hex bolt.
9. Repeat steps 2-6 above to verify proper adjustment has been achieved.
10. Confirm that the auger has completely stopped rotating and shows NO signs of motion. If the auger shows ANY signs of rotating, immediately return to the operator's position and shut off the engine. Wait for ALL moving parts to stop before adjusting the auger control.



Figure 14

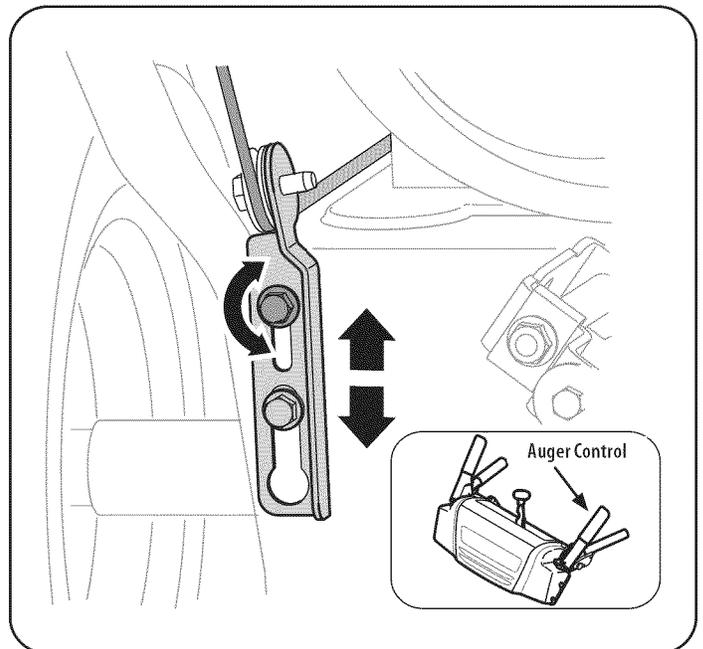

Figure 15

# OPERATION

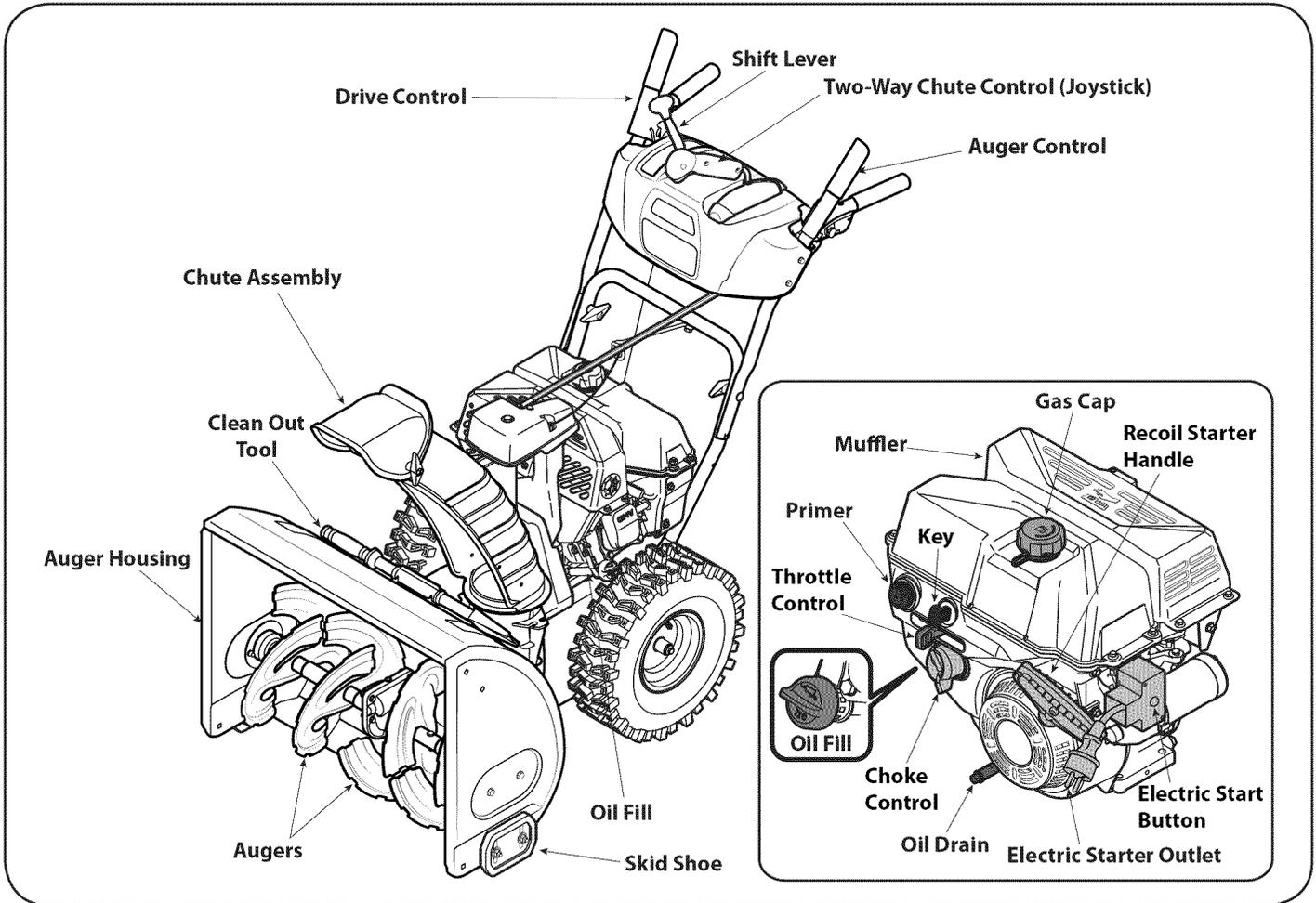

Figure 16

Now that you have set up your snow thrower, it's important to become acquainted with its controls and features. Refer to Figure 16.

## Shift Lever

The shift lever is located on the right side of the handle panel. Place the shift lever into any of eight positions to control the direction of travel and ground speed. Forward

Your snow thrower has six forward (F) speeds. Position one (1) is the slowest and position six (6) is the fastest.

## Reverse

Your snow thrower has two reverse (R) speeds. One (1) is the slower and two (2) is the faster.

## Key

**6** The key is a safety device. It must be fully inserted in order for the engine to start. Remove the key when the snow thrower is not in use.

**5**  
**4** **NOTE:** Do not turn the ignition key in an attempt to start the engine. Doing so may cause it to break.

## Choke Control

**3**  
**2** The choke control is found on the rear of the engine and is activated by turning the rotary choke knob to the CHOKE position. Activating the choke control closes the choke plate on the carburetor and aids in starting the engine.

## Recoil Starter Handle

This handle is used to manually start the engine.

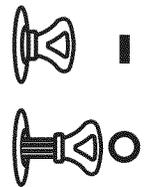

## Meets ANSI Safety Standards

Craftsman Snow Throwers conform to the safety standard of the American National Standards Institute (ANSI).

# OPERATION

## Throttle control



The throttle control is located on the rear of the engine. It regulates the speed of the engine and will shut off the engine when moved into the STOP position.

## Primer

Depressing the primer forces fuel directly into the engine's carburetor to aid in cold-weather starting.

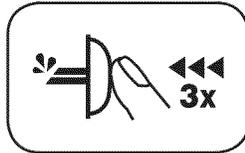

## Electric Starter Button

Pressing the electric starter button engages the engine's electric starter when plugged into a 120V power source.

## Electric Starter Outlet

Requires the use of a three-prong outdoor extension cord and a 120V power source/wall outlet.

## Oil Fill

Engine oil level can be checked and oil added through the oil fill.

## Gas Cap

Unthread the gas cap to add gasoline to the fuel tank.

## Auger

When engaged, the auger blades rotate and draw snow into the auger housing.

## Chute Assembly

Snow drawn into the auger housing is discharged out the chute assembly.

## Skid Shoes

Position the skid shoes based on surface conditions. Adjust upward for hard-packed snow. Adjust downward when operating on gravel or crushed rock surfaces.

## Auger Control

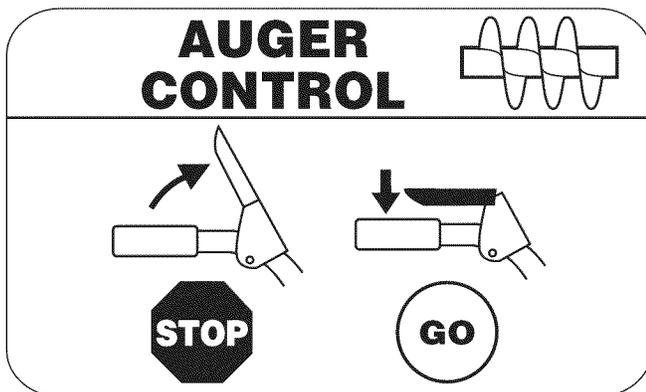

The auger control is located on the left handle. Squeeze the control grip against the handle to engage the auger and start snow throwing action. Release to stop.

## Drive Control/ Auger Control Lock

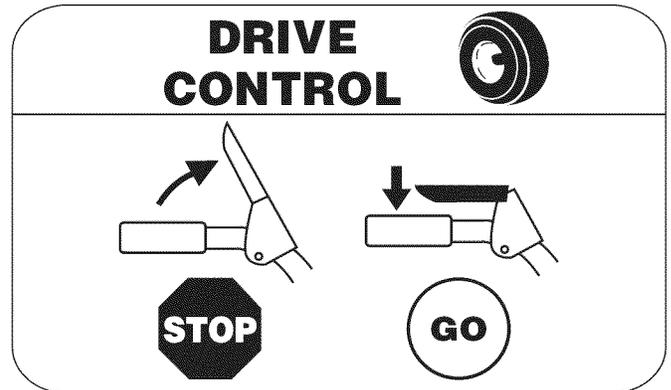

The drive control is located on the right handle. Squeeze the control grip against the handle to engage the wheel drive. Release to stop.

The drive control also locks the auger control so you can operate the chute directional control without interrupting the snow throwing process. If the auger control is engaged simultaneously with the drive control, the operator can release the auger control (on the left handle) and the augers will remain engaged. Release both controls to stop the augers and wheel drive.

**NOTE:** Always release the drive control before changing speeds. Failure to do so will result in increased wear on your machine's drive system.

## Two-Way Chute Control

The two-way chute control (Joystick) is located on the left side of the handle panel.

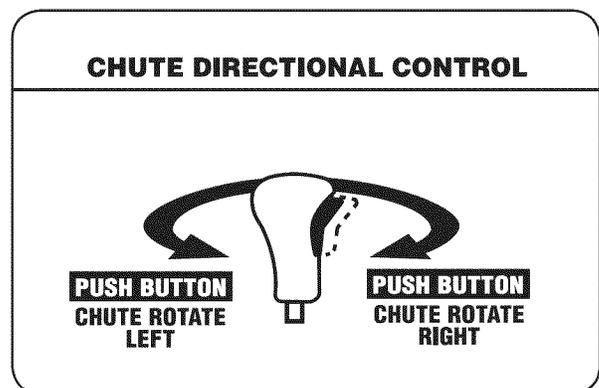

- To change the direction in which snow is thrown, squeeze the button on the chute control lever and pivot the chute control lever to the right or to the left.

# OPERATION

## Clean-Out Tool

### WARNING

Never use your hands to clear a clogged chute assembly. Shut off engine and remain behind handles until all moving parts have stopped before using the clean-out tool to clear the chute assembly.

The chute clean-out tool is conveniently fastened to the rear of the auger housing with a mounting clip. Should snow and ice become lodged in the chute assembly during operation, proceed as follows to safely clean the chute assembly and chute opening:

1. Release both the Auger Control and the Drive Control.
2. Stop the engine by removing the ignition key.
3. Remove the clean-out tool from the clip which secures it to the rear of the auger housing.
4. Use the shovel-shaped end of the clean-out tool to dislodge and scoop any snow and ice which has formed in and near the chute assembly.
5. Refasten the clean-out tool to the mounting clip on the rear of the auger housing, reinsert the ignition key and start the snow thrower's engine.
6. While standing in the operator's position (behind the snow thrower), engage the auger control for a few seconds to clear any remaining snow and ice from the chute assembly.

## Before Starting Engine

### WARNING

Read, understand, and follow all instructions and warnings on the machine and in this manual before operating.

## Oil

The unit was shipped with oil in the engine. Check oil level before each operation to ensure adequate oil in the engine.

**NOTE:** Be sure to check the engine on a level surface with the engine stopped.

1. Remove the oil filler cap/dipstick and wipe the dipstick clean.
2. Insert the cap/dipstick into the oil filler neck, but do NOT screw it in.
3. Remove the oil filler cap/dipstick. If the level is low, slowly add oil (5W-30, with a minimum classification of SF/SG) until oil level registers between high (H) and low (L).

**NOTE:** Do not overfill. Overfilling with oil may result in engine smoking, hard starting or spark plug fouling.

4. Replace and tighten cap/dipstick firmly before starting engine.

## Gasoline

Use automotive gasoline (unleaded or low leaded to minimize combustion chamber deposits) with a minimum of 87 octane. Gasoline with up to 10% ethanol or 15% MTBE (Methyl Tertiary Butyl Ether) can be used. Never use an oil/gasoline mixture or dirty gasoline. Avoid getting dirt, dust, or water in the fuel tank. DO NOT use E85 gasoline.

- Refuel in a well-ventilated area with the engine stopped. Do not smoke or allow flames or sparks in the area where the engine is refueled or where gasoline is stored.

- Do not overfill the fuel tank. After refueling, make sure the tank cap is closed properly and securely.
- Be careful not to spill fuel when refueling. Spilled fuel or fuel vapor may ignite. If any fuel is spilled, make sure the area is dry before starting the engine.
- Avoid repeated or prolonged contact with skin or breathing of vapor.

### WARNING

Use extreme care when handling gasoline. Gasoline is extremely flammable and the vapors are explosive. Never fuel the machine indoors or while the engine is hot or running. Extinguish cigarettes, cigars, pipes and other sources of ignition.

1. Clean around fuel fill before removing cap to fuel.
2. A fuel level indicator is located in the fuel tank. See Figure 16 inset. Be careful not to overfill. Fill tank until fuel reaches the fuel level indicator to allow space for fuel expansion.

## Starting The Engine

### WARNING

Always keep hands and feet clear of moving parts. Do not use a pressurized starting fluid. Vapors are flammable.

**NOTE:** Allow the engine to warm up for a few minutes after starting. The engine will not develop full power until it reaches operating temperatures.

1. Make certain both the auger control and drive control are in the disengaged (released) position.
2. Insert key into slot. Make sure it snaps into place. Do not attempt to turn the key.

**NOTE:** The engine cannot start without the key fully inserted into the ignition switch.

## Electric Starter

### WARNING

The electric starter is designed to operate on 120 volt AC household current. It must be used with a properly grounded extension cord and three-prong receptacle at all times to avoid the possibility of electric shock. Follow all instructions carefully prior to operating the electric starter. DO NOT use electric starter in the rain.

Determine that your home's wiring is a three-wire grounded system. Ask a licensed electrician if you are not certain.

If you have a grounded three-prong receptacle, proceed as follows. If you do not have the proper house wiring, DO NOT use the electric starter under any conditions.

1. Plug an extension cord into the outlet located on the engine's surface. Plug the other end of extension cord into a three-prong 120-volt, grounded, AC outlet in a well-ventilated area.

### CAUTION

The extension cord can be any length, but *must* be rated for 15 amps at 125 volts, grounded and rated for outdoor use.

# OPERATION

2. Move throttle control to FAST (rabbit)  position.
3. Move choke to the CHOKE  position (cold engine start). If engine is warm, place choke in RUN position.
4. Push primer three (3) times, making sure to cover vent hole in primer bulb when pushing. If engine is warm, push primer only once. Always cover vent hole when pushing. Cool weather may require priming to be repeated.
5. Push starter button to start engine. Once the engine starts, immediately release starter button. Electric starter is equipped with thermal overload protection; system will temporarily shut-down to allow starter to cool if electric starter becomes overloaded.
6. As the engine warms, slowly rotate the choke control to RUN position. If the engine falters, restart engine and run with choke at half-choke position for a short period of time, and then slowly rotate the choke into RUN position.
7. After engine is running, disconnect power cord from electric starter. When disconnecting, always unplug the end at the wall outlet before unplugging the opposite end from the engine.

## Recoil Starter

### CAUTION

Do not pull the starter handle while the engine running.

1. Move throttle control to FAST (rabbit)  position.
2. Move choke to the CHOKE  position (cold engine start). If engine is warm, place choke in RUN position.
3. Push primer three (3) times, making sure to cover vent hole when pushing. If engine is warm, push primer only once. Always cover vent hole when pushing. Cool weather may require priming to be repeated.
4. Pull gently on the starter handle until it begins to resist, then pull quickly and forcefully to overcome the compression. Do not release the handle and allow it to snap back. Return rope SLOWLY to original position. If required, repeat this step.
5. As the engine warms, slowly rotate the choke control to RUN position. If the engine falters, restart engine and run with choke at half-choke position for a short period of time, and then slowly rotate the choke into RUN position.

### WARNING

To avoid unsupervised engine operation, never leave the machine unattended with the engine running. Turn the engine off after use and remove key.

## Stopping The Engine

After you have finished snow-throwing, run engine for a few minutes before stopping to help dry off any moisture on the engine.

1. Move throttle control to OFF position.
2. Remove the key. Removing the key will reduce the possibility of unauthorized starting of the engine while equipment is not in use. Keep the key in a safe place. The engine cannot start without the key.
3. Wipe any moisture away from the controls on the engine.

## To Engage Drive

1. With the throttle control in the Fast (rabbit)  position, move shift lever into one of the six forward (F) positions or two reverse (R) positions. Select a speed appropriate for the snow conditions and a pace you're comfortable with.

**NOTE:** When selecting a Drive Speed, use the slower speeds until you are comfortable and familiar with the operation of the snow thrower.

2. Squeeze the drive control against the handle and the snow thrower will move. Release it and drive motion will stop.

**NOTE:** NEVER reposition the shift lever (change speeds or direction of travel) without first releasing the drive control and bringing the snow thrower to a complete stop. Doing so will result in premature wear to the snow thrower's drive system.

## To Engage Auger

1. To engage the auger and start throwing snow, squeeze the auger control against the left handle. Release to stop the auger.

## Replacing Shear Pins

Each auger blade is secured to the spiral shaft with a shear pin and bow-tie clip. If an auger blade strikes a foreign object or ice jam, the pin will shear off to prevent damage to the blade. If an auger blade does not turn, check to see if its pin has sheared off. See Figure 17.

### CAUTION

NEVER replace the auger shear pins with anything other than Sears SKU# 88389/OEM Part No. 738-04124A replacement shear pins. Any damage to the auger gearbox or other components as a result of failing to do so will NOT be covered by your snow thrower's warranty.

### WARNING

Always turn off the snow thrower's engine and remove the key prior to replacing shear pins.

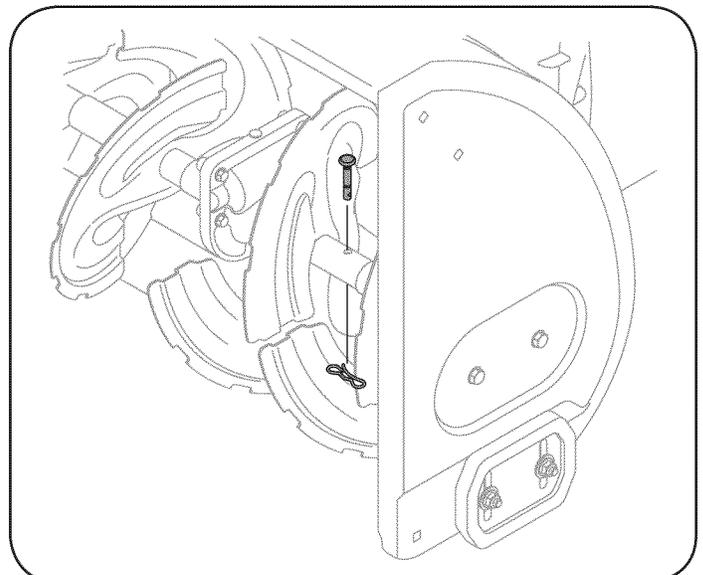

Figure 17

# SERVICE AND MAINTENANCE

## MAINTENANCE SCHEDULE

### ⚠ WARNING

Before performing any type of maintenance/service, disengage all controls and stop the engine. Wait until all moving parts have come to a complete stop. Disconnect spark plug wire and ground it against the engine to prevent unintended starting.

Follow the maintenance schedule given below. This chart describes service guidelines only. Use the Service Log column to keep track of completed maintenance tasks. To locate the nearest Sears Service Center or to schedule service, call the following toll free number: 1-888-331-4569.

Interval	Item	Service	Service Log
Each Use and every 5 hours	<ol style="list-style-type: none"> <li>1. Engine oil level</li> <li>2. Loose or missing hardware</li> <li>3. Unit and engine.</li> </ol>	<ol style="list-style-type: none"> <li>1. Check</li> <li>2. Tighten or replace</li> <li>3. Clean</li> </ol>	
1st 5 hours	<ol style="list-style-type: none"> <li>1. Engine oil</li> </ol>	<ol style="list-style-type: none"> <li>1. Change</li> </ol>	
Annually or 25 hours	<ol style="list-style-type: none"> <li>1. Spark plug</li> <li>2. Control linkages and pivots</li> <li>3. Wheels</li> <li>4. Gear shaft and Auger shaft</li> </ol>	<ol style="list-style-type: none"> <li>1. Check</li> <li>2. Lube with light oil</li> <li>3. Lube with multipurpose auto grease</li> <li>4. Lube with light oil</li> </ol>	
Annually or 50 hours	<ol style="list-style-type: none"> <li>1. Engine oil</li> </ol>	<ol style="list-style-type: none"> <li>1. Change</li> </ol>	
Annually or 100 hours	<ol style="list-style-type: none"> <li>1. Spark plug</li> </ol>	<ol style="list-style-type: none"> <li>1. Change</li> </ol>	
Before Storage	<ol style="list-style-type: none"> <li>1. Fuel system</li> </ol>	<ol style="list-style-type: none"> <li>1. Run engine until it stops from lack of fuel</li> </ol>	

## GENERAL RECOMMENDATIONS

### Checking Engine Oil

### ⚠ WARNING

Before lubricating, repairing, or inspecting, disengage all controls and stop engine. Wait until all moving parts have come to a complete stop.

**NOTE:** Check the oil level before each use to be sure correct oil level is maintained.

When adding oil to the engine, refer to viscosity chart below. Engine oil capacity is 600 ml (approx. 20 oz.). Do not over-fill. Use a 4-stroke, or an equivalent high detergent, premium quality motor oil certified to meet or exceed U.S. automobile manufacturer's requirements for service classification SG, SF. Motor oils classified SG, SF will show this designation on the container.

1. Remove the oil filler cap/dipstick and wipe the dipstick clean.
2. Insert the cap/dipstick into the oil filler neck, but do NOT screw it in.
3. Remove the oil filler cap/dipstick. If level is low, slowly add oil until oil level registers between high (H) and low (L). See Figure 18.
4. Replace and tighten cap/dipstick firmly before starting engine.

### Changing Engine Oil

**NOTE:** Change the engine oil after the first 5 hours of operation and once a season or every 50 hours thereafter.

1. Drain fuel from tank by running engine until the fuel tank is empty. Be sure fuel fill cap is secure.
2. Place suitable oil collection container under oil drain plug.
3. Remove oil drain plug and washer. See Figure 19 on next page.
4. Tip unit to drain oil into the container. Used oil must be disposed of at a proper collection center.

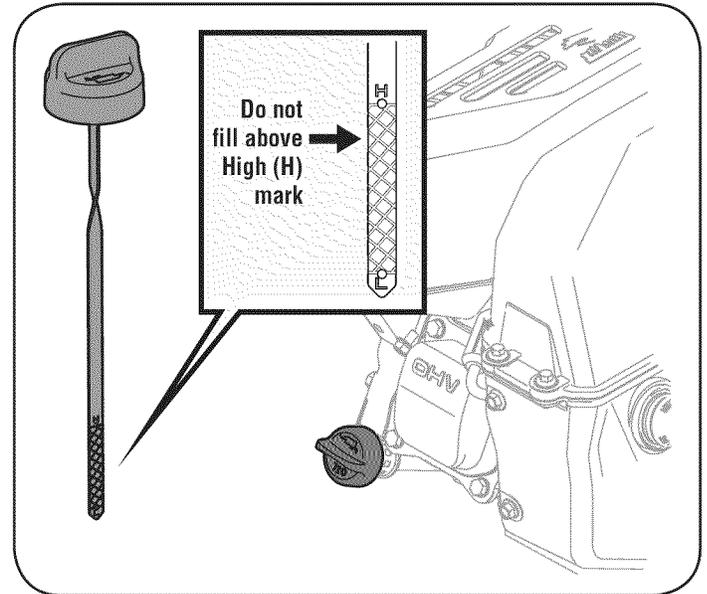

Figure 18

### ⚠ CAUTION

Used oil is a hazardous waste product. Dispose of used oil properly. Do not discard with household waste. Check with your local authorities or Sears Service Center for safe disposal/recycling facilities.

5. Reinstall the drain plug and washer and tighten it securely.

# SERVICE AND MAINTENANCE

6. Refill with the recommended oil and check the oil level. See Recommended Oil Usage chart. The engine's oil capacity is 20 ounces.

	Synthetic 0W-30				
	5W-30				
(°F)	-40°	-20°	0°	20°	40°
(°C)	-30°	-20°	-10°	0°	

## CAUTION

DO NOT use nondetergent oil or 2-stroke engine oil. It could shorten the engine's service life.

7. Reinstall the oil filler cap/dipstick securely.

## CAUTION

Thoroughly wash your hands with soap and water as soon as possible after handling used oil.

## Checking Spark Plug

## WARNING

DO NOT check for spark with spark plug removed. DO NOT crank engine with spark plug removed.

## WARNING

If the engine has been running, the muffler will be very hot. Be careful not to touch the muffler.

**NOTE:** Check the spark plug once a season or every 25 hours of operation. Change the spark plug once a season or every 100 hours. To ensure proper engine operation, the spark plug must be properly gapped and free of deposits.

1. Remove the spark plug boot and use a spark plug wrench to remove the plug. See Figure 20.
2. Visually inspect the spark plug. Discard the spark plug if there is apparent wear, or if the insulator is cracked or chipped. Clean the spark plug with a wire brush if it is to be reused.
3. Measure the plug gap with a feeler gauge. Correct as necessary by bending side electrode. See Figure 21. The gap should be set to .02-.03 inches (0.60-0.80 mm).
4. Check that the spark plug washer is in good condition and thread the spark plug in by hand to prevent cross-threading.
5. After the spark plug is seated, tighten with a spark plug wrench to compress the washer.

**NOTE:** When installing a new spark plug, tighten 1/2-turn after the spark plug seats to compress the washer. When reinstalling a used spark plug, tighten 1/8- to 1/4-turn after the spark plug seats to compress the washer.

## CAUTION

The spark plug must be tightened securely. A loose spark plug can become very hot and can damage the engine.

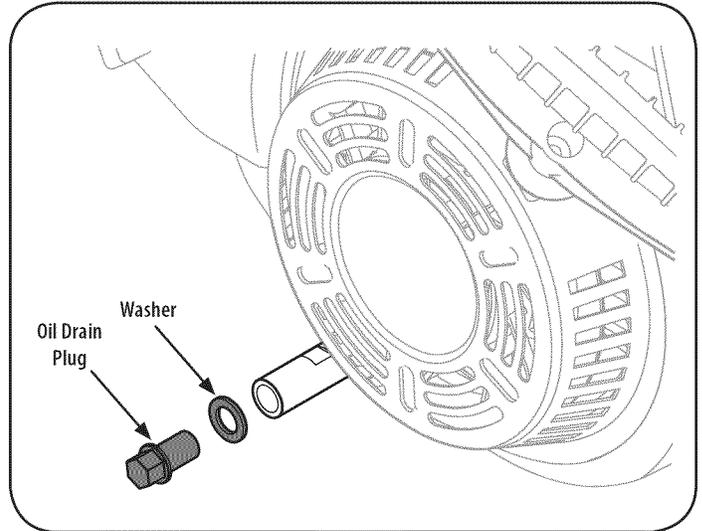

Figure 19

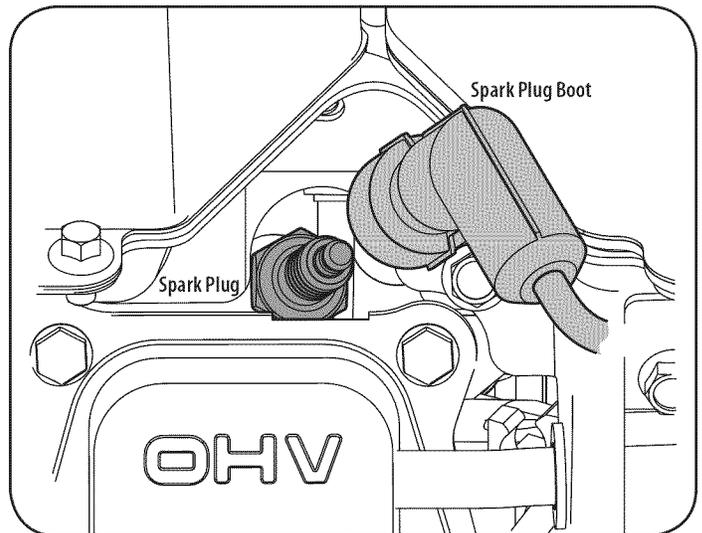

Figure 20

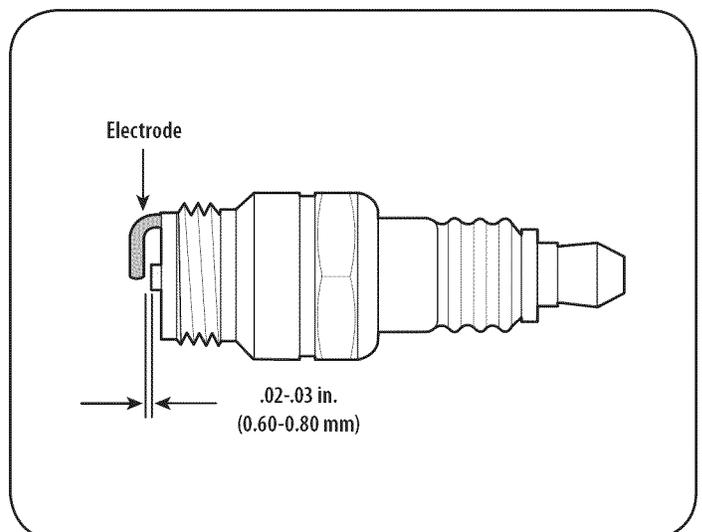

Figure 21

# SERVICE AND MAINTENANCE

## Lubrication

### Gear Shaft

The gear (hex) shaft should be lubricated at least once a season or after every 25 hours of operation.

1. To prevent spillage, remove all fuel from tank by running engine until it stops.
2. Carefully pivot the snow thrower up and forward so that it rests on the auger housing.
3. Remove the lower frame cover from the underside of the snow thrower by removing the self-tapping screws which secure it.
4. Apply a light coating of anti-seize to the hex shaft. See Figure 22.

**NOTE:** When lubricating the hex shaft, be careful not to get any anti-seize on the aluminum drive plate or rubber friction wheel. Doing so will hinder the snow thrower's drive system. Wipe off any excess or spilled anti-seize.

### Wheels

At least once a season, remove both wheels. Clean and coat the axles with a multipurpose automotive grease before reinstalling wheels.

### Auger Shaft

At least once a season, remove the shear pins on auger shaft. Spray lubricant inside shaft, and around the spacers and flange bearings found at either end of the shaft. See Figure 23.

### Shave Plate and Skid Shoes

The shave plate and skid shoes on the bottom of the snow thrower are subject to wear. They should be checked periodically and replaced when necessary.

**NOTE:** The skid shoes on this machine have two wear edges. When one side wears out, they can be rotated 180° to use the other edge.

To remove skid shoes:

1. Remove the two carriage bolts, washers, and hex flange nuts that secure each skid shoe to the snow thrower.
2. Reassemble new skid shoes with the four carriage bolts (two on each side), washers, and hex flange nuts. Refer to Figure 24.

To remove shave plate:

1. Remove the carriage bolts and hex nuts which attach it to the snow thrower housing.
2. Reassemble new shave plate, making sure heads of carriage bolts are to the inside of housing. Tighten securely. See Figure 24.

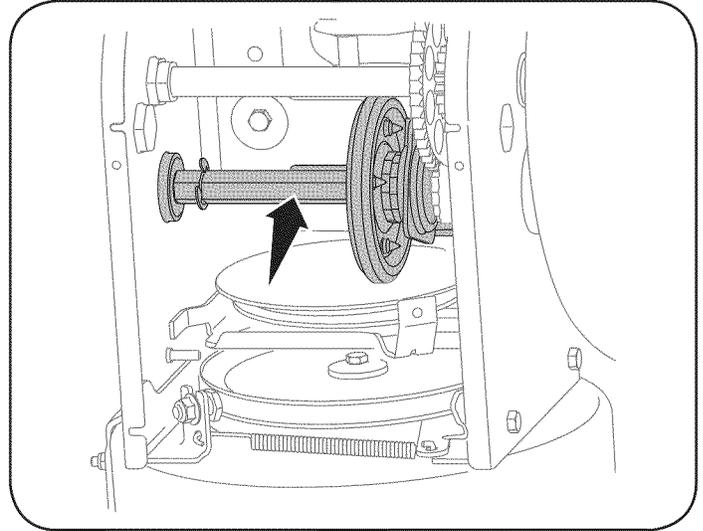

Figure 22

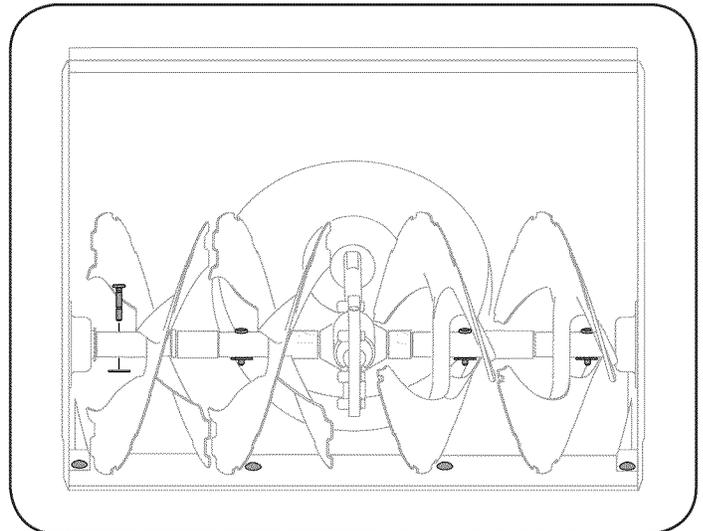

Figure 23

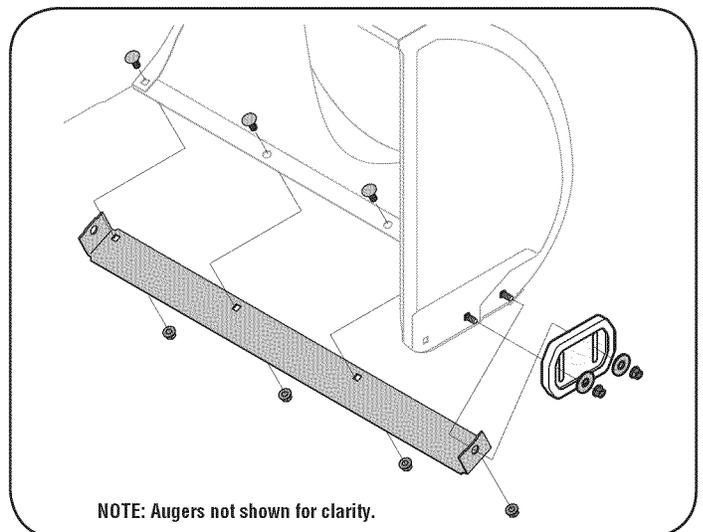

Figure 24

# SERVICE AND MAINTENANCE

## Adjustments

### Shift Cable

If the full range of speeds (forward and reverse) cannot be achieved, refer to the figure to the right and adjust the shift cable as follows:

1. Place the shift lever in the fastest forward speed position (F6).
2. Loosen the hex nut on the shift cable index bracket. See Figure 25.
3. Pivot the bracket downward to take up slack in the cable.
4. Retighten the hex nut.

### Drive Control

When the drive control is released and in the disengaged “up” position, the cable should have very little slack. It should NOT be tight. Also, if there is excessive slack in the drive cable or if the unit experiences intermittent drive while using, the cable may need to be adjusted. Check the adjustment of the drive control as follows:

1. With the drive control released, push the snow thrower gently forward. The unit should roll freely.
2. Engage the drive control and gently attempt to push the snow thrower forward. The wheels should not turn. The unit should not roll freely.
3. With the drive control released, move the shift lever back and forth between the R2 position and the F6 position several times. There should be no resistance in the shift lever.
4. If any of the above tests failed, the drive cable is in need of adjustment. Proceed as follows:
  - a. Shut off the engine as instructed in the Operation section.
  - b. Loosen the lower hex bolt on the drive cable bracket. See Figure 26.
  - c. Position the bracket upward to provide more slack (or downward to increase cable tension).
  - d. Retighten the lower hex bolt.

### Chute Control Rod

To achieve more chute control rod engagement in the input shaft under the handle panel, the chute control rod will have to be adjusted. Refer to Figure 27.

To adjust this rod, proceed as follows:

1. Remove the cotter pin from the hole closest to the chute control head on the chute control input.
2. Pull out the chute control rod until the hole in it lines up with the other hole in the chute control input.
3. Reinsert the cotter pin through this hole and the chute control rod.

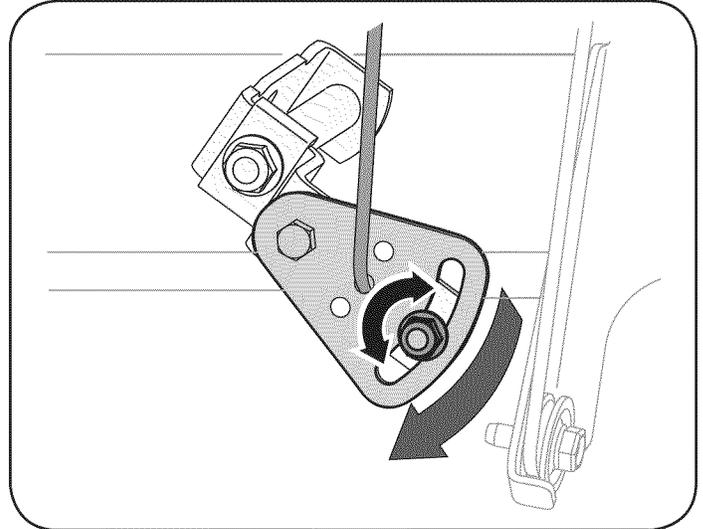

Figure 25

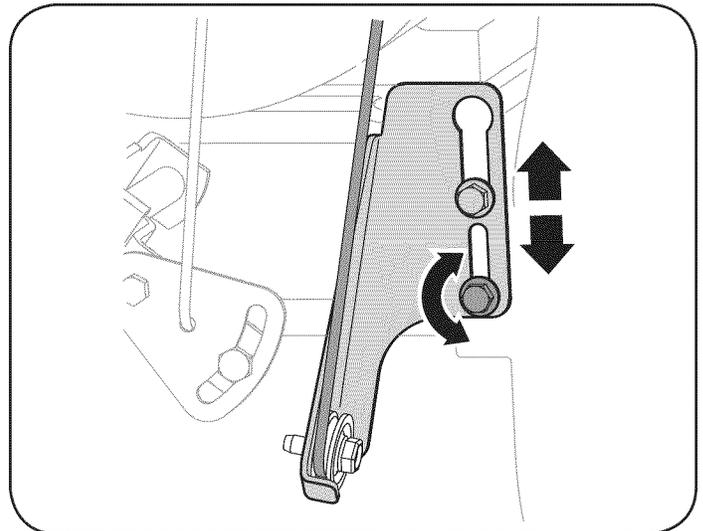

Figure 26

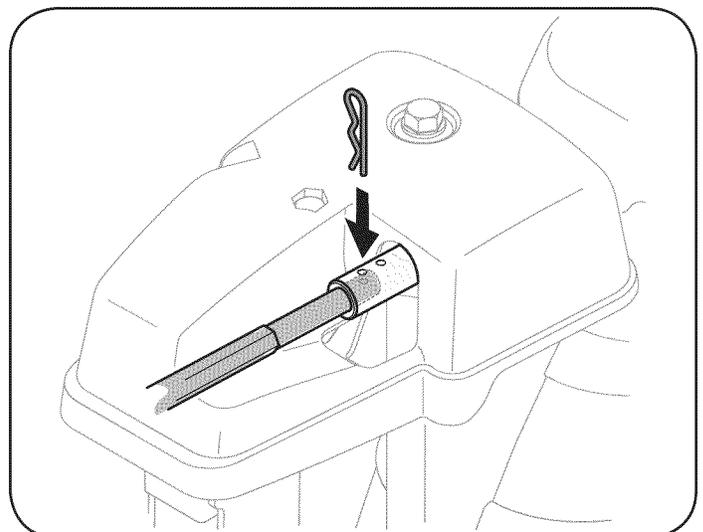

Figure 27

# SERVICE AND MAINTENANCE

## Auger Control

Refer to the Assembly section for instructions on adjusting the auger control cable.

## Skid Shoes

Refer to the Assembly section for instructions on adjusting the skid shoes.

## Belt Replacement

### Auger Belt

To remove and replace your snow thrower's auger belt, proceed as follows:

1. To prevent spillage, remove all fuel from tank by running engine until it stops.
2. Remove the plastic belt cover on the front of the engine by removing the two self-tapping screws. See Figure 28.
3. Loosen and remove the two bolts and flat washers securing the belt guide. See Figure 29. Remove belt guide.
4. Roll the auger belt off the engine pulley. See Figure 30.
5. Carefully pivot the snow thrower up and forward so that it rests on the auger housing.
6. Remove the frame cover from the underside of the snow thrower by removing four self-tapping screws which secure it. See Figure 31.

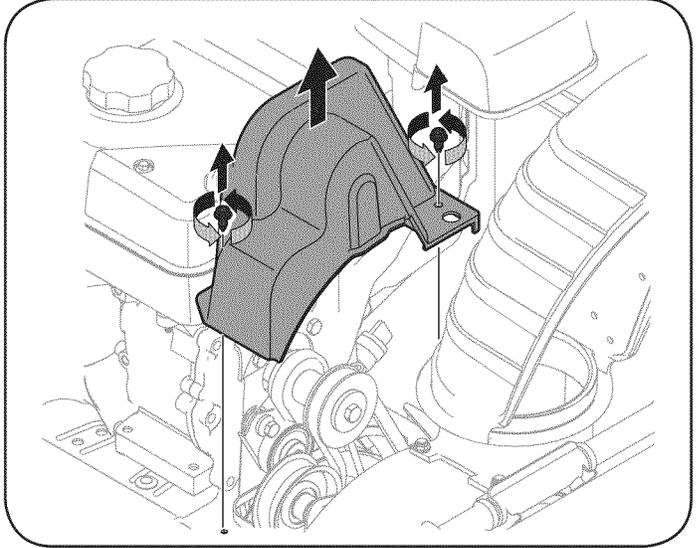

Figure 28

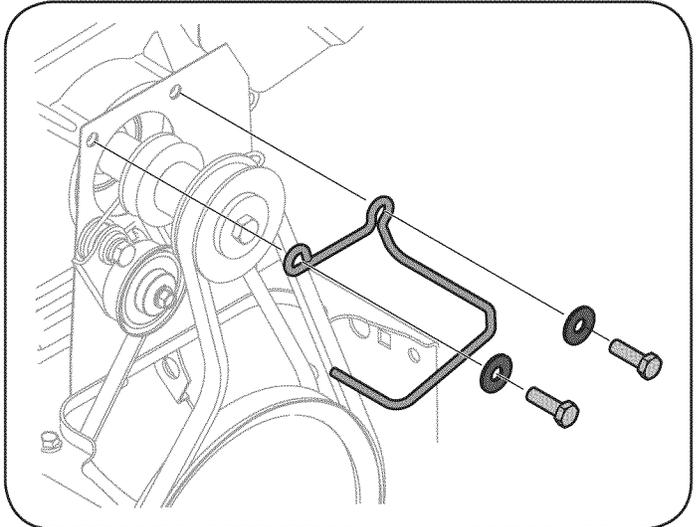

Figure 29

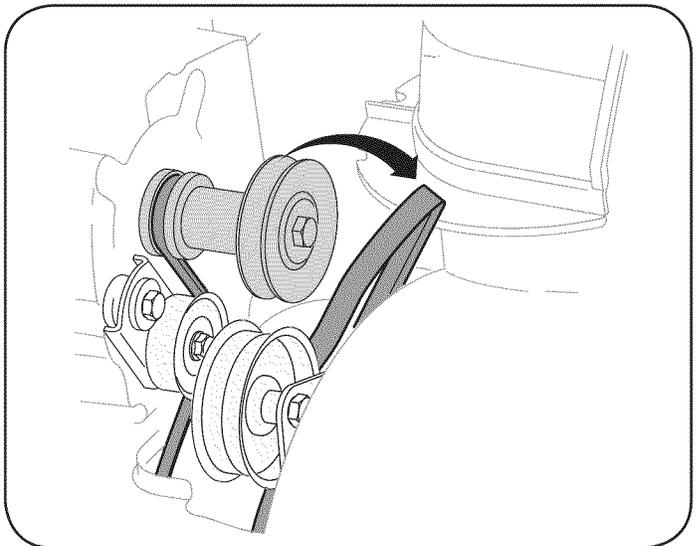

Figure 30

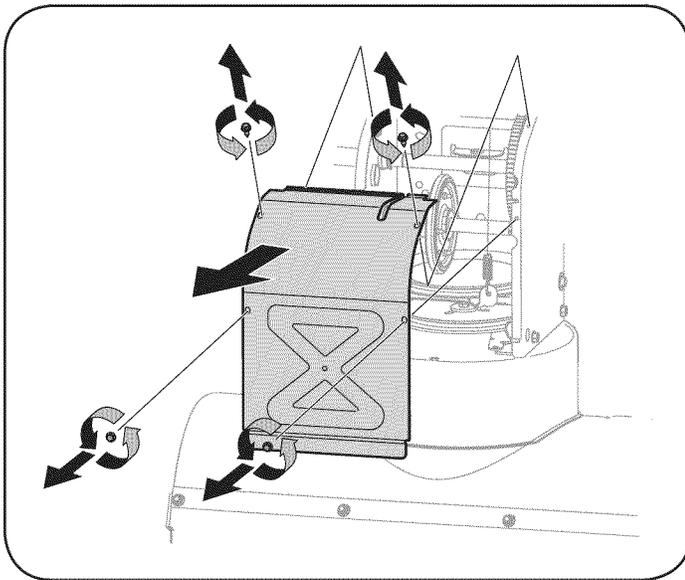

Figure 31

## SERVICE AND MAINTENANCE

- Loosen and remove the shoulder screw which acts as a belt keeper. Refer to Figure 32.
- Remove the belt from around the auger pulley, and slip the belt between the support bracket and the auger pulley. See Figure 33.  
**NOTE:** Engaging the auger control will ease removal and reinstallation of the belt.
- Reassemble auger belt by following instructions in reverse order.  
**NOTE:** Do NOT forget to reinstall the shoulder screw and reconnect the spring to the frame after installing a replacement auger belt.
- Perform the Auger Control test outlined in the Assembly section of this manual.

### Drive Belt

**NOTE:** Several components must be removed and special tools are required in order to replace the snow thrower's drive belt. Contact the nearest Sears Parts & Repair Center to have the drive belt replaced.

### Friction Wheel Removal

If the snow thrower fails to drive with the drive control engaged, and performing the drive control cable adjustment fails to correct the problem, the friction wheel may need to be replaced. Follow the instructions below. Examine the friction wheel rubber for signs of wear or cracking and replace wheel if necessary.

- To prevent spillage, remove all fuel from tank by running engine until it stops.
- Place the shift lever in first Forward (F1) position.
- Carefully pivot the snow thrower up and forward so that it rests on the auger housing.
- Remove the frame cover from the underside of the snow thrower by removing the self-tapping screws which secure it.
- Remove the right-hand wheel by removing the screw and bell washer which secure it to the axle. See Figure 34.

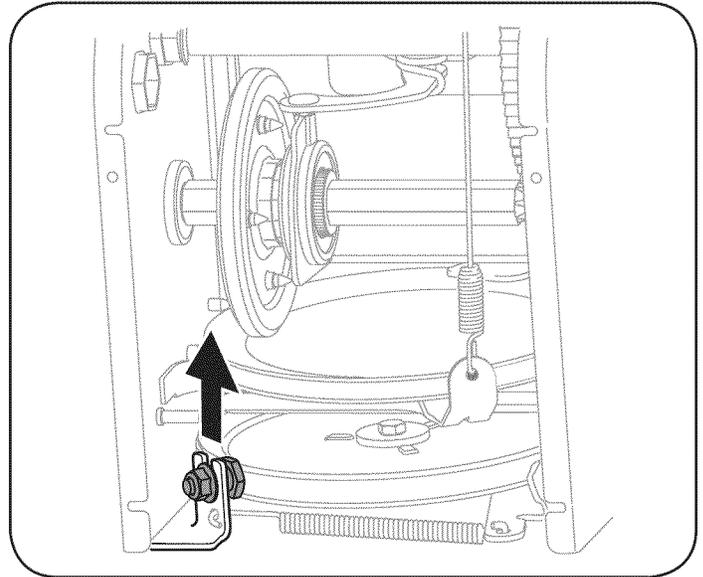

Figure 32

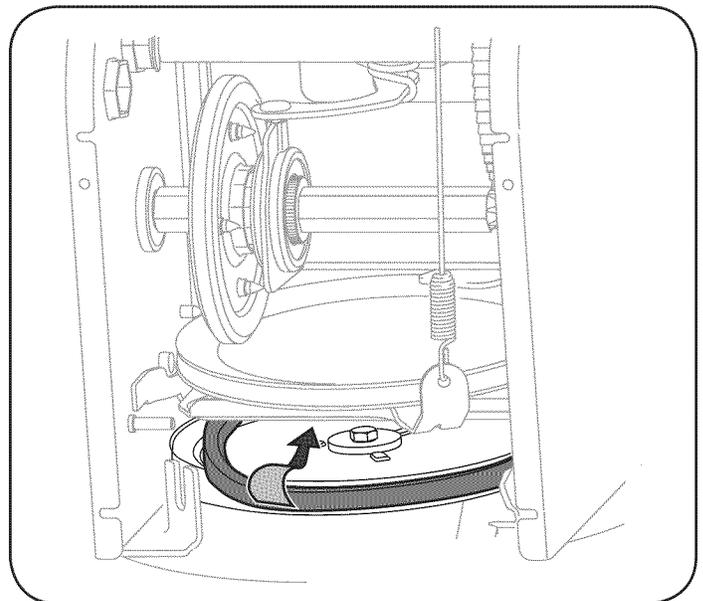

Figure 33

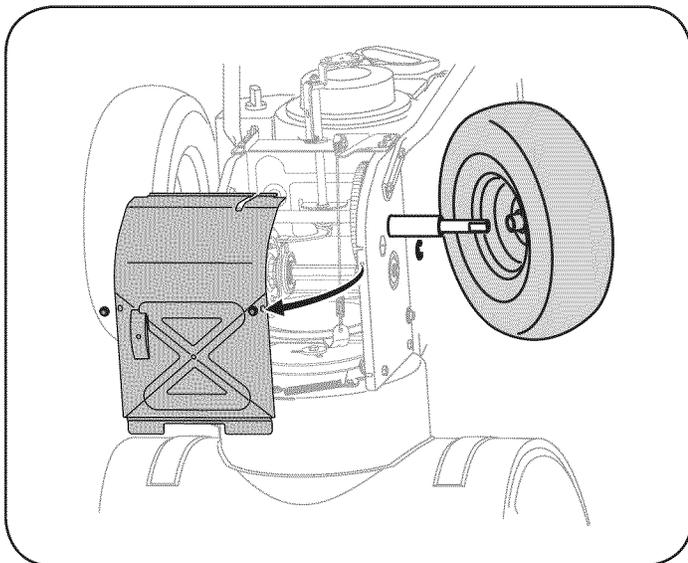

Figure 34

## SERVICE AND MAINTENANCE

- Carefully remove the hex nut and washer which secures the hex shaft to the snow thrower frame and lightly tap the shaft's end to dislodge the ball bearing from the right side of the frame. See Figure 35.

**NOTE:** Be careful not to damage the threads on the shaft.

- Carefully position the hex shaft downward and to the left before carefully sliding the friction wheel assembly off the shaft. See Figure 36.

**NOTE:** If you're replacing the friction wheel assembly as a whole, discard the worn part and slide the new part onto the hex shaft.

- Follow the steps above in reverse order to reassemble components.
- Perform the test previously described in the Drive Control section.

If you're disassembling the friction wheel and replacing only the rubber ring, proceed as follows:

**NOTE:** Not all friction wheels are serviceable. If this is the case, simply replace the friction wheel assembly.

- Remove the four screws which secure the friction wheel's side plates together. See Figure 37.
- Remove the rubber ring from between the plates.
- Reassemble the side plates with a new rubber ring.

**NOTE:** When reassembling the friction wheel assembly, make sure that the rubber ring is centered and seated properly between the side plates. Tighten each screw only one rotation before turning the wheel clockwise and proceeding with the next screw. Repeat this process several times to ensure the plates are secured with equal force (between 6 ft-lbs and 9 ft-lbs).

- Slide the friction wheel assembly back onto the hex shaft and follow the steps above in reverse order to reassemble components.
- Perform the test previously described in the Drive Control section.

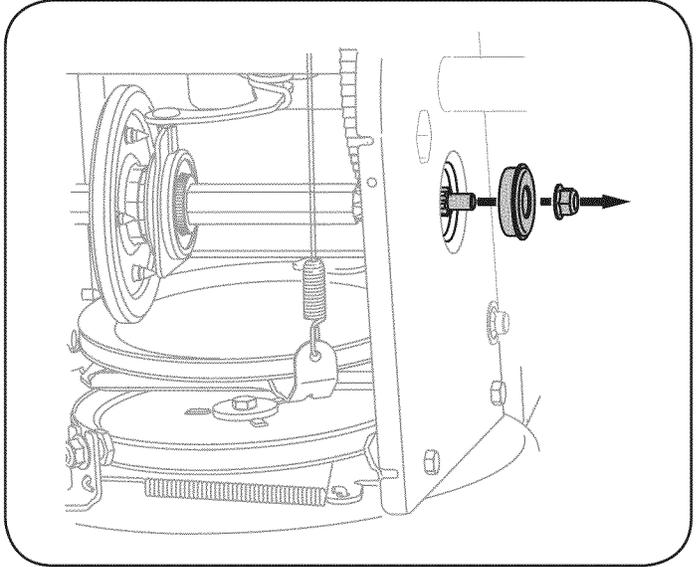

Figure 35

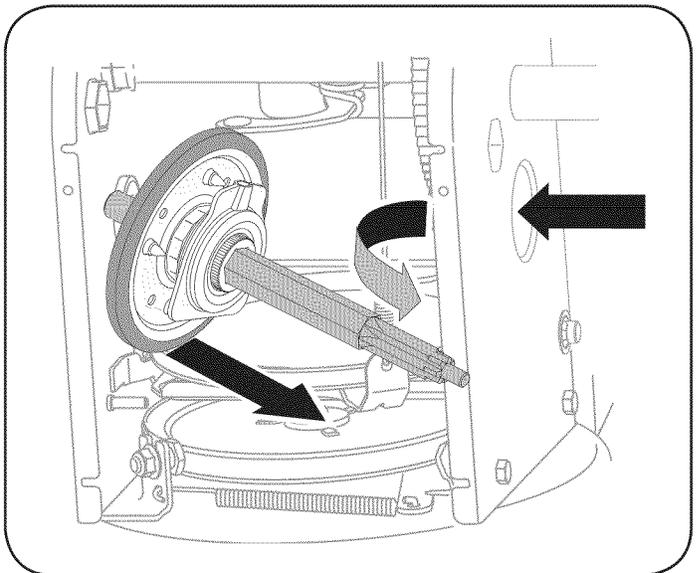

Figure 36

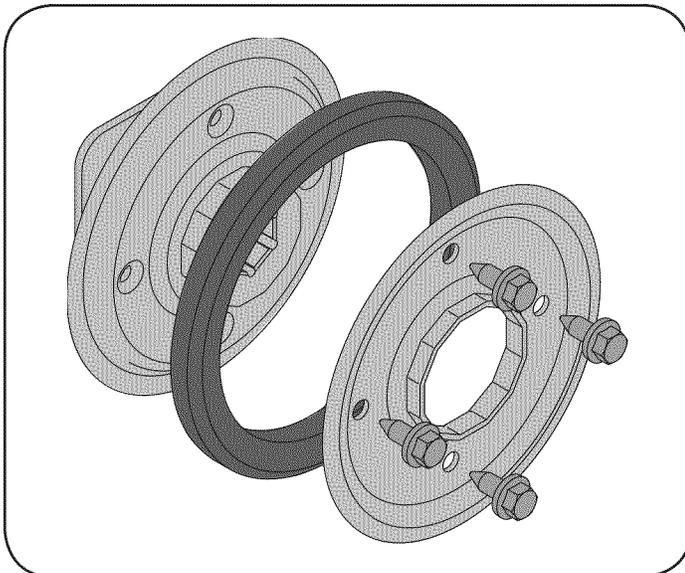

Figure 37

# OFF-SEASON STORAGE

If the snow thrower will not be used for 30 days or longer, or if it is the end of the snow season when the last possibility of snow is gone, the equipment needs to be stored properly. Follow storage instructions below to ensure top performance from the snow thrower for many more years.

## Preparing Engine

Engines stored over 30 days need to be drained of fuel to prevent deterioration and gum from forming in fuel system or on essential carburetor parts. If the gasoline in your engine deteriorates during storage, you may need to have the carburetor, and other fuel system components, serviced or replaced.

1. Remove all fuel from tank by running engine until it stops. Do not attempt to pour fuel from the engine.
  2. Change the engine oil.
  3. Remove spark plug and pour approximately 1 oz. (30 ml) of clean engine oil into the cylinder. Pull the recoil starter several times to distribute the oil, and reinstall the spark plug.
  4. Clean debris from around engine, and under, around, and behind muffler. Apply a light film of oil on any areas that are susceptible to rust.
- Store in a clean, dry and well ventilated area away from any appliance that operates with a flame or pilot light, such as a furnace, water heater, or clothes dryer. Avoid any area with a spark producing electric motor, or where power tools are operated.

### WARNING

Never store snow thrower with fuel in tank indoors or in poorly ventilated areas, where fuel fumes may reach an open flame, spark or pilot light as on a furnace, water heater, clothes dryer or gas appliance.

- If possible, avoid storage areas with high humidity.
- Keep the engine level in storage. Tilting can cause fuel or oil leakage.

## Preparing Snow Thrower

- When storing the snow thrower in an unventilated or metal storage shed, care should be taken to rustproof the equipment. Using a light oil or silicone, coat the equipment, especially any chains, springs, bearings and cables.
- Remove all dirt from exterior of engine and equipment.
- Follow lubrication recommendations.
- Store equipment in a clean, dry area.
- Inflate the tires to the maximum PSI. Refer to tire sidewall.

# TROUBLESHOOTING

## ⚠ WARNING

Disconnect the spark plug wire and ground it against the engine to prevent unintended starting. Before performing any type of maintenance/service, disengage all controls and stop the engine. Wait until all moving parts have come to a complete stop. Always wear safety glasses during operation or while performing any adjustments or repairs.

This section addresses minor service issues. To locate the nearest Sears Service Center or to schedule service, call the following toll free number: 1-888-331-4569.

Problem	Cause	Remedy
Engine fails to start	<ol style="list-style-type: none"> <li>1. Choke control not in CHOKE position.</li> <li>2. Spark plug wire disconnected.</li> <li>3. Faulty spark plug.</li> <li>4. Fuel tank empty or stale fuel.</li> <li>5. Engine not primed.</li> <li>6. Key not inserted.</li> <li>7. Extension cord not connected (when using electric start button, on models so equipped).</li> </ol>	<ol style="list-style-type: none"> <li>1. Move choke control to CHOKE position.</li> <li>2. Connect wire to spark plug.</li> <li>3. Clean, adjust gap, or replace.</li> <li>4. Fill tank with clean, fresh gasoline.</li> <li>5. Prime engine as instructed in the Operation Section.</li> <li>6. Insert key fully into the switch.</li> <li>7. Connect one end of the extension cord to the electric starter outlet and the other end to a three-prong 120-volt, grounded, AC outlet.</li> </ol>
Engine running erratically/ inconsistent RPM (hunting or surging)	<ol style="list-style-type: none"> <li>1. Engine running on CHOKE.</li> <li>2. Stale fuel.</li> <li>3. Water or dirt in fuel system.</li> <li>4. Carburetor out of adjustment.</li> <li>5. Over-governed engine.</li> </ol>	<ol style="list-style-type: none"> <li>1. Move choke control to RUN position.</li> <li>2. Fill tank with clean, fresh gasoline.</li> <li>3. Drain fuel tank by running engine until it stops. Refill with fresh fuel.</li> <li>4. Contact your Sears Parts &amp; Repair Center.</li> <li>5. Contact your Sears Parts &amp; Repair Center.</li> </ol>
Excessive vibration	<ol style="list-style-type: none"> <li>1. Loose parts or damaged auger.</li> </ol>	<ol style="list-style-type: none"> <li>1. Stop engine immediately and disconnect spark plug wire. Tighten all bolts and nuts. If vibration continues, have unit serviced by a Sears Parts &amp; Repair Center.</li> </ol>
Loss of power	<ol style="list-style-type: none"> <li>1. Spark plug wire loose.</li> <li>2. Gas cap vent hole plugged.</li> </ol>	<ol style="list-style-type: none"> <li>1. Connect and tighten spark plug wire.</li> <li>2. Remove ice and snow from gas cap. Be certain vent hole is clear.</li> </ol>
Unit fails to propel itself	<ol style="list-style-type: none"> <li>1. Drive cable in need of adjustment.</li> <li>2. Drive belt loose or damaged.</li> <li>3. Worn friction wheel.</li> </ol>	<ol style="list-style-type: none"> <li>1. Adjust drive control cable. Refer to Service and Maintenance section.</li> <li>2. Have drive belt replaced. Contact your Sears Parts &amp; Repair Center.</li> <li>3. Have friction wheel replaced at a Sears Parts &amp; Repair Center.</li> </ol>

### NEED MORE HELP?

You'll find the answer and more on [managemylife.com](http://managemylife.com) – for free!

- Find this and all your other product manuals online.
- Get answers from our team of home experts.
- Get a personalized maintenance plan for your home.
- Find information and tools to help with home projects.



brought to you by Sears

# TROUBLESHOOTING

Problem	Cause	Remedy
Unit fails to discharge snow	<ol style="list-style-type: none"> <li>1. Chute assembly clogged.</li> <li>2. Foreign object lodged in auger.</li> <li>3. Auger cable in need of adjustment.</li> <li>4. Auger belt loose or damaged.</li> <li>5. Shear pin(s) sheared.</li> </ol>	<ol style="list-style-type: none"> <li>1. Stop engine immediately and disconnect spark plug wire. Clean chute assembly and inside of auger housing with clean-out tool or a stick.</li> <li>2. Stop engine immediately and disconnect spark plug wire. Remove object from auger with clean-out tool or a stick.</li> <li>3. Adjust auger control cable. Refer to Assembly section.</li> <li>4. Replace auger belt. Refer to Service and Maintenance section.</li> <li>5. Replace with new shear pin(s).</li> </ol>
Chute fails to easily rotate 180 degrees	<ol style="list-style-type: none"> <li>1. Chute assembled incorrectly.</li> </ol>	<ol style="list-style-type: none"> <li>1. Disassemble chute control and reassemble as directed in the Assembly section.</li> </ol>

## NEED MORE HELP?

You'll find the answer and more on [managemylife.com](http://managemylife.com) -- for free!

- Find this and all your other product manuals online.
- Get answers from our team of home experts.
- Get a personalized maintenance plan for your home.
- Find information and tools to help with home projects.



brought to you by Sears

---

**FEDERAL and/or CALIFORNIA EMISSION CONTROL WARRANTY STATEMENT**  
**YOUR WARRANTY RIGHTS AND OBLIGATIONS**

MTD Consumer Group Inc, the United States Environmental Protection Agency (EPA), and for those products certified for sale in the state of California, the California Air Resources Board (CARB) are pleased to explain the emission control system (ECS) warranty on your 2013-2014 small off-road spark-ignited engine and equipment (outdoor equipment). In California, new outdoor equipment must be designed, built and equipped to meet the State's stringent anti-smog standards (in other states, outdoor equipment must be designed, built, and equipped to meet the U.S. EPA small off-road spark ignition engine regulations). MTD Consumer Group Inc must warrant the ECS on your outdoor equipment for the period of time listed below, provided there has been no abuse, neglect, or improper maintenance of the outdoor equipment.

Your ECS may include parts such as the carburetor, fuel-injection system, ignition system, catalytic converter, fuel tanks, fuel lines, fuel caps, valves, canisters, filters, vapor hoses, clamps, connectors, and other associated emission-related components.

Where a warrantable condition exists, MTD Consumer Group Inc will repair your outdoor equipment at no cost to you including diagnosis, parts, and labor.

**MANUFACTURER'S WARRANTY COVERAGE:**

This emission control system is warranted for two years. If any emission-related part on your outdoor equipment is defective, the part will be repaired or replaced by MTD Consumer Group Inc.

**OWNER'S WARRANTY RESPONSIBILITIES:**

As the outdoor equipment owner, you are responsible for performance of the required maintenance listed in your owner's manual. MTD Consumer Group Inc recommends that you retain all receipts covering maintenance on your outdoor equipment, but MTD Consumer Group Inc cannot deny warranty solely for the lack of receipts.

As the outdoor equipment owner, you should however be aware that MTD Consumer Group Inc may deny you warranty coverage if your outdoor equipment or a part has failed due to abuse, neglect, improper maintenance, or unapproved modifications.

You are responsible for presenting your outdoor equipment to MTD Consumer Group Inc's distribution center or service center as soon as the problem exists. The warranty repairs should be completed in a reasonable amount of time, not to exceed 30 days. If you have a question regarding your warranty coverage, you should contact the MTD Consumer Group Inc Service Department at 1-800-800-7310 or at <http://support.mtdproducts.com>.

**GENERAL EMISSIONS WARRANTY COVERAGE:**

MTD Consumer Group Inc warrants to the ultimate purchaser and each subsequent purchaser that the outdoor equipment is: (1) designed, built, and equipped so as to conform with all applicable regulations; and (2) free from defects in materials and workmanship that cause the failure of a warranted part for a period of two years.

The warranty period begins on the date the outdoor equipment is delivered to an ultimate purchaser or first placed into service.

Subject to certain conditions and exclusions as stated below, the warranty on emission-related parts is as follows:

1. Any warranted part that is not scheduled for replacement as required maintenance in the written instructions supplied is warranted for the warranty period stated above. If the part fails during the period of warranty coverage, the part will be repaired or replaced by MTD Consumer Group Inc according to subsection (4) below. Any such part repaired or replaced under warranty will be warranted for the remainder of the period.
  2. Any warranted part that is scheduled only for regular inspection in the written instructions supplied is warranted for the warranty period stated above. Any such part repaired or replaced under warranty will be warranted for the remaining warranty period.
  3. Any warranted part that is scheduled for replacement as required maintenance in the written instructions supplied is warranted for the period of time before the first scheduled replacement date for that part. If the part fails before the first scheduled replacement, the part will be repaired or replaced by MTD Consumer Group Inc according to subsection (4) below. Any such part repaired or replaced under warranty will be warranted for the remainder of the period prior to the first scheduled replacement point for the part.
  4. Repair or replacement of any warranted part under the warranty provisions herein must be performed at a warranty station at no charge to the owner.
  5. Notwithstanding the provisions herein, warranty services or repairs will be provided at all of our distribution centers that are franchised to service the subject engines or equipment.
  6. The outdoor equipment owner will not be charged for diagnostic labor that is directly associated with diagnosis of a defective, emission-related warranted part, provided that such diagnostic work is performed at a warranty station.
  7. MTD Consumer Group Inc is liable for damages to other engine or equipment components proximately caused by a failure under warranty of any warranted part.
  8. Throughout the off-road engine and equipment warranty period stated above, MTD Consumer Group Inc will maintain a supply of warranted parts sufficient to meet the expected demand for such parts.
  9. Any replacement part may be used in the performance of any warranty maintenance or repairs and must be provided without charge to the owner. Such use will not reduce the warranty obligations of MTD Consumer Group Inc.
-

- 
10. Add-on or modified parts that are not exempted by the Air Resources Board may not be used. The use of any non-exempted add-on or modified parts by the ultimate purchaser will be grounds for disallowing a warranty claim. MTD Consumer Group Inc will not be liable to warrant failures of warranted parts caused by the use of a non-exempted add-on or modified part.

### **WARRANTED PARTS:**

The repair or replacement of any warranted part otherwise eligible for warranty coverage may be excluded from such warranty coverage if MTD Consumer Group Inc demonstrates that the outdoor equipment has been abused, neglected, or improperly maintained, and that such abuse, neglect, or improper maintenance was the direct cause of the need for repair or replacement of the part. That notwithstanding, any adjustment of a component that has a factory installed, and properly operating, adjustment limiting device is still eligible for warranty coverage. Further, the coverage under this warranty extends only to parts that were present on the off-road equipment purchased.

The following emission warranty parts are covered (if applicable):

1. Fuel Metering System
  - Cold start enrichment system (soft choke)
  - Carburetor and internal parts (or fuel injection system)
  - Fuel pump
  - Fuel tank
2. Air Induction System
  - Air cleaner
  - Intake manifold
3. Ignition System
  - Spark plug(s)
  - Magneto ignition system
4. Exhaust System
  - Catalytic converter
  - SAI (Reed valve)
5. Miscellaneous Items Used in Above System
  - Vacuum, temperature, position, time sensitive valves and switches
  - Connectors and assemblies
6. Evaporative Control
  - Fuel hose
  - Fuel hose clamps
  - Tethered fuel cap
  - Carbon canister
  - Vapor lines

## REPAIR PROTECTION AGREEMENT

*Congratulations on making a smart purchase. Your new Craftsman® product is designed and manufactured for years of dependable operation. But like all products, it may require repair from time to time. That's when having a Repair Protection Agreement can save you money and aggravation.*

### **Here's what the Repair Protection Agreement\* includes:**

- ☑ **Expert service** by our 10,000 professional repair specialists
- ☑ **Unlimited service and no charge** for parts and labor on all covered repairs
- ☑ **Product replacement** up to \$1500 if your covered product can't be fixed
- ☑ **Discount of 25%** from regular price of service and related installed parts not covered by the agreement; also, 25% off regular price of preventive maintenance check
- ☑ **Fast help by phone** – we call it Rapid Resolution – phone support from a Sears representative. Think of us as a “talking owner's manual.”

Once you purchase the Repair Protection Agreement, a simple phone call is all that it takes for you to schedule service. You can call anytime day or night, or schedule a service appointment online.

The Repair Protection Agreement is a risk-free purchase. If you cancel for any reason during the product warranty period, we will provide a full refund. Or, a prorated refund anytime after the product warranty period expires. Purchase your Repair Protection Agreement today!

**Some limitations and exclusions apply. For prices and additional information in the U.S.A. call 1-800-827-6655.**

**\*Coverage in Canada varies on some items. For full details call Sears Canada at 1-800-361-6665.**

Sears Installation Service

*For Sears professional installation of home appliances, garage door openers, water heaters, and other major home items, in the U.S.A. or Canada call **1-800-4-MY-HOME®**.*

# **CRAFTSMAN®**

**Product questions or problems?**

# **1-888-331-4569**

## **Customer Care Hot Line**

**Get answers to questions, troubleshoot problems,  
order parts, or schedule repair service.**

Para respuestas a preguntas o problemas, y ordenar  
piezas o pedir servicio para la reparación de su equipo.

**To help us help you, register your product at [www.craftsman.com/registration](http://www.craftsman.com/registration)**

Para poderte ayudar mejor, registra tu producto en [www.craftsman.com/registration](http://www.craftsman.com/registration)

---

**Join the Craftsman Club today!**

# **CRAFTSMAN® CLUB**

**[www.craftsman.com/signup](http://www.craftsman.com/signup)**

**Receive exclusive member benefits including special pricing and offers,  
project sharing, expert advice, and SHOP YOUR WAY REWARDS!**

Como miembro exclusivo, recibe diversos beneficios como ofertas, precios especiales, proyectos nuevos, consejos de expertos y nuestro programa de puntos SHOP YOUR WAY REWARDS!

## Free Manuals Download Website

<http://myh66.com>

<http://usermanuals.us>

<http://www.somanuals.com>

<http://www.4manuals.cc>

<http://www.manual-lib.com>

<http://www.404manual.com>

<http://www.luxmanual.com>

<http://aubethermostatmanual.com>

Golf course search by state

<http://golfingnear.com>

Email search by domain

<http://emailbydomain.com>

Auto manuals search

<http://auto.somanuals.com>

TV manuals search

<http://tv.somanuals.com>